

## **Copyright Warning & Restrictions**

The copyright law of the United States (Title 17, United States Code) governs the making of photocopies or other reproductions of copyrighted material.

Under certain conditions specified in the law, libraries and archives are authorized to furnish a photocopy or other reproduction. One of these specified conditions is that the photocopy or reproduction is not to be “used for any purpose other than private study, scholarship, or research.” If a user makes a request for, or later uses, a photocopy or reproduction for purposes in excess of “fair use” that user may be liable for copyright infringement,

This institution reserves the right to refuse to accept a copying order if, in its judgment, fulfillment of the order would involve violation of copyright law.

**Please Note: The author retains the copyright while the New Jersey Institute of Technology reserves the right to distribute this thesis or dissertation**

Printing note: If you do not wish to print this page, then select “Pages from: first page # to: last page #” on the print dialog screen

The Van Houten library has removed some of the personal information and all signatures from the approval page and biographical sketches of theses and dissertations in order to protect the identity of NJIT graduates and faculty.

## **ABSTRACT**

### **LITHIUM AS A POSSIBLE THERAPEUTIC DRUG IN POST-TRAUMATIC BRAIN INJURY**

**by  
Tulika Das**

Lithium, a popular drug for treating mental health disorder has shown promising effect in recent research on traumatic brain injury (TBI). The mechanism of lithium for treating bipolar mood disorder is still not properly understood, but recent studies showed that lithium is neuroprotective in TBI. In my thesis, the neuroprotective effects of lithium were examined in primary neuronal culture and mild blunt injury using rodent model of Lateral Fluid Percussion Injury (LFPI). At first determination of the neuroprotective/toxicity effects of lithium in neuronal culture was done and observed that 0.5 - 1.0 mM concentrations were found to be neuroprotective as per cell viability assay. This optimized 1.0 mM lithium was then administered to injured animals to evaluate if lithium can restore the injury at day 1, 3, and 7 post-TBI. Fluorescent labeled tracer (2000 kDa) was also deposited in the CSF directly to trace the time-dependent recovery of the damaged CSF-subarachnoid circulation by lithium. Tracer level as seen in the scanned images of the treated tissue sections, indicated the amount of lithium in blood circulation, supporting the theory that more amount of tracer indicates more leakage of the tracer due to rupture of Blood Brain Barrier (BBB) which can be caused by the injury. Quantification of Cresyl Violet labeled neurons in brain tissue sections shows an increase in neuronal cell number when treated with lithium post injury. The data collected by me for this thesis, supports the theory that lithium protects neurons against excitotoxicity effects of various chemicals, resulted by traumatic brain injury.

**LITHIUM AS A POSSIBLE THERAPEUTIC DRUG IN POST-  
TRAUMATIC BRAIN INJURY**

by  
**Tulika Das**

**A Thesis  
Submitted to the Faculty of  
New Jersey Institute of Technology  
in Fulfillment of the Requirements for the Degree of  
Master of Science in Biomedical Engineering**

**Department of Biomedical Engineering**

**December 2020**

Blank Page

**APPROVAL PAGE**

**EFFECT OF LITHIUM AFTER TRAUMATIC BRAIN INJURY (TBI)**

**Tulika Das**

---

Dr. James Haorah, Thesis Advisor Date  
Associate Professor of Biomedical Engineering, NJIT

---

Dr. Bryan J. Pfister, Committee Member Date  
Professor and Chair of Biomedical Engineering, NJIT

---

Dr. Jonathan M. Grasman, Committee Member Date  
Assistant Professor of Biomedical Engineering, NJIT

## **BIOGRAPHICAL SKETCH**

**Author:** Tulika Das  
**Degree:** Master of Science  
**Date:** December 2020

### **Undergraduate and Graduate Education:**

- Master of Science in Biomedical Engineering,  
New Jersey Institute of Technology, New Jersey, 2020
- Bachelor of Technology in Applied Electronics and Instrumentation  
Engineering,  
Heritage Institute of Technology, Kolkata, India, 2018

**Major:** Biomedical Engineering

### **Research projects:**

Tulika Das with advisor Dr. Sagnik Basuray “*Biosensor Based on Shear Enhanced Nano-porous Capacitive Electrodes*”, New Jersey Institute of Technology, Undergraduate Summer Program, 2017

*To my mom and dad. To my person.*

*Thank you for helping me to reach here and support me throughout the journey.*



## ACKNOWLEDGMENT

Thank you, Dr. James Haorah for your mentorship, support, advisement, time and allowing me to join your lab.

Thank you, Dr. Bryan Pfister and Dr. Jonathan Grasman, for your suggestions and time to be a part of my thesis committee. Additional thank you, to Dr. Namas Chandra and Dr. Venkata Kakulavarapu for letting me use their lab for some parts of my experiments.

Thank you Agnieszka Agas, Jessica Xiaotang Ma and Yiming Cheng for your assistance and showing me different techniques in experiment preparation and data collection and welcoming me into the lab. Additional thanks to Agnieszka for your immense help in cell culture, cortical neuron isolation and staining procedure. Thank you, Ningning Shao and Aswati Aravind for showing me staining procedures and helping me with imaging.

I would like to thank all the lab members, my friends and family for providing support during this journey.

## TABLE OF CONTENTS

1	INTRODUCTION.....	1
1.1	Objective .....	1
1.2	Traumatic Brain Injury (TBI) .....	2
1.3	Uses of Lithium as a drug .....	6
1.4	Pharmacokinetics of Lithium .....	10
2	AIM 1 : DETERMINATION OF OPTIMUM DOSAGE OF LITHIUM FOR ANIMAL USAGE .....	11
2.1	Hypothesis Approach .....	11
2.2	Lithium Toxicity .....	11
2.3	Levels of Lithium Toxicity .....	12
2.4	Methods and Materials .....	15
2.5	Result and Analysis .....	17
2.6	Discussion .....	21
3	AIM 2 : HEALING EFFECTS OF LITHIUM AFTER MILD TRAUMATIC BRAIN INJURY.....	23
3.1	Hypothesis Approach .....	22
3.2	Neuroprotective Effects of Lithium .....	22
3.3	Methods and Materials .....	25
3.4	Results and Analysis .....	29
3.5	Discussion .....	36
4	CONCLUSION .....	37

**TABLE OF CONTENTS**  
**(Continued)**

5 FUTURE PERSPECTIVE .....	39
REFERENCES .....	42

## LIST OF TABLES

2.1	Lithium Toxicity .....	14
2.2	MTT Assay – Absorbance of Lithium by Cortical Neural Cells .....	17
3.1	Experimental Design .....	29
3.2	Absorbance Values of Tracer in Rats that have Undergone Mild Traumatic Brain Injury and Lithium Treatment.....	29

## LIST OF FIGURES

1.1	Types of Brain Injury .....	2
1.2	Causes of TBI .....	3
1.3	American Association of Neurological Surgeons TBI Reports .....	4
1.4	TBI Modulation of Various Neurological Signaling Pathways .....	5
1.5	Physiochemical and Toxicokinetic Properties of Lithium .....	6
1.6	Effects of Lithium at Microscopic Level on Neurotransmission and Intracellular and Molecular Pathways .....	10
2.1	Step-by-Step Procedure of Neuronal Dissection .....	16
2.2	Bar Graph of Cell Metabolic Activity Results .....	18
2.3	Neural Cell Culture Treatment Images .....	20
3.1	Pathways of Neuroprotective Mechanisms of Lithium .....	24
3.2	Gross Observation of Injured Brain .....	27
3.3	Tracer Level in Brain Sections .....	30
3.4	Bar Graph of Plasma Results .....	32
3.5	Scanned Images of Brain Section .....	33
3.6	Representative Figures Showing Cell Count .....	34
3.7	Bar Graph of Cell Count .....	35
5.1	GSK-3 regulates Wnt and Akt-dependent Signaling .....	40

## LIST OF SYMBOLS

10x	Magnification of image by multiple of 10
ATP/Mg <sup>2+</sup>	Adenosine Triphosphate per Magnesium ion
BBB	Blood-Brain Barrier
Bcl-2	A Protein that regulates cell death
BDNF	Brain-Derived Neurotrophic Factor
BrdU	Bromodeoxyuridine / 5-bromo-2'-deoxyuridine
CREB	A cellular transcription factor
CSF	Cerebrospinal Fluid
DPX	A synthetic resin used to preserve a stain
FBS	Fetal Bovine Serum
FITC	Fluorescein Isothiocyanate
g	Grams
GAA	A gene that provides instructions for producing an enzyme called acid alpha-glucosidase
GABA	Gamma Aminobutyric Acid
GSK-3	A signal molecule
H <sub>2</sub> O	Water
ImPase	Inositol Phosphate-Phosphatase
IPPase	Soluble Inorganic Pyrophosphatase

**LIST OF SYMBOLS**  
**(Continued)**

L/kg	Liters per kilograms
LFP	Lateral Fluid Percussion
LiCl	Lithium Chloride
MDD	Major Depressive Disorder
mEq/L	Milliequivalents per liter
mg/ml	Milligrams per milliliter
mM	Millimolar
mmol/L	Millimolar per Liter
MTT	3-(4,5-dimethylthiazol-2-yl)-2,5-diphenyltetrazolium bromide
nm	Nanometer(s)
NMDA	N-Methyl-D-Aspartate
OCT	Optimal Cutting Temperature compound
p53	A protein acts as a tumor suppressor
PBS	Phosphate-Buffered Saline
PI3K/Akt	Phosphoinositide 3-kinase per Protein kinase B
RNA	Ribonucleic Acid
RPM	Rotation per minute
TBI	Traumatic Brain Injury
w/v	Weight per volume
Wnt	Wingless-related integration site

## LIST OF DEFINITIONS

Alkaline	The condition of water or soil which contains enough alkali substances to raise the pH above 7.0.
Antiapoptotic	The prevention of the cytolytic process where cells disintegrate, and surrounding cells use the remaining parts.
Astrocyte	The star shaped glial cell of the central nervous system.
Axon	The threadlike part of a nerve cell along which impulses are conducted from the cell body to other cells.
Bonferroni correction	A statistical method used to confront the problem of multiple comparisons.
Cortices	The outer layers of the cerebral cortex.
ELISA reader	A tool that uses spectrophotometry by emitting light at one wavelength and measures the amount of light absorbed by an object which can be used to measure multiple samples at once.
Epilepticus	Two or more seizures within a five-minute period without the person returning to normal in between or a single seizure lasting more than five minutes.
Excitotoxins	A class of chemicals that overstimulate neuron receptors.
Growth factors	A naturally occurring substance capable of stimulating cell proliferation, wound healing, and occasional cellular differentiation.
Herniation	A deadly side effect of high pressure within the skull that occurs when a part of the brain is squeezed across structures within the skull.
Histiocyte	A type of white blood cell that is created by the bone marrow.
Intracisternal	A method of administering a drug directly into the cerebrospinal fluid of the brain ventricles.



## LIST OF DEFINITIONS

(Continued)

Lymphocytes	White blood cells that are made in the bone marrow and found in the blood and lymph tissue that work as the body's main types of immune cells.
MTT Assay	The MTT assay is a colorimetric assay which measures cellular metabolic activity as an indicator of cell viability, proliferation, and cytotoxicity. The principle of this assay based on the reduction of a yellow tetrazolium salt 3-(4,5-dimethylthiazol-2-yl)-2,5-diphenyltetrazolium bromide or MTT to purple formazan crystals by metabolically active cells. The viable cells contain NAD(P)H-dependent oxidoreductase enzymes which reduce the MTT to formazan. The insoluble formazan crystals are dissolved solution is quantified by measuring absorbance at 500-600 nm using multiwell spectrophotometer. The darker the solution, the greater number of viable, metabolically active cells.
Myocardial	a heart attack that occurs when blood flow decreases or stops at a part of the heart, causing damage to the heart muscle.
Pilocarpine	A medication used to reduce pressure inside the eye and treat dry mouth.
Postsynaptic	A neuron that receives the neurotransmitter after it has crossed the synapse.
Presynaptic	A nerve cell that releases a transmitter substance into a synapse during transmission of an impulse.
Schizophrenia	Mental health disorder in which people interpret reality abnormally.
Striatal	Having to do with the corpus striatum in the subcortical basal ganglia of the forebrain.
Supernatant	A characteristic of a liquid lying above a solid residue after crystallization, precipitation, centrifugation, or other chemical process.
Thiazide diuretics	A type of drug that increases urine flow by directly acting on the kidneys to promote urine flow.
Uremic	A complication of chronic kidney disease and acute kidney injury which occurs when urea and other waste products build up in the body.
Valproate	Forms of medication used to treat epilepsy and bipolar disorder.

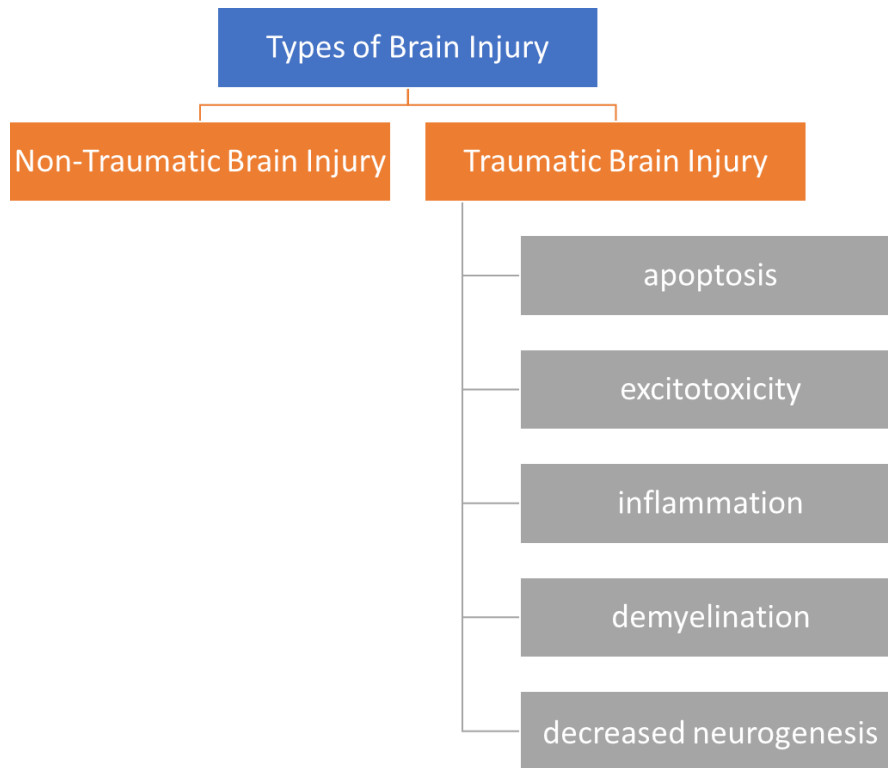
# **CHAPTER 1 INTRODUCTION**

## **1.1 Objective**

The main objective of this thesis is to explore the less-known applications of lithium as a drug other than mental health. In recent studies, lithium has shown promising effects after traumatic brain injury (TBI). For this thesis, the therapeutic dosage of Lithium for animal usage will be determined (aim 1) in cell culture studies with and without glutamate injury. In the animal model, histology study will be performed to observe the neuroprotective effect of Lithium after mild traumatic brain injury (aim 2). Finally, this thesis will discuss the idea of a few possible mechanisms and future prospects of lithium as a stimulation for neurogenesis.

## 1.2 Traumatic Brain Injury (TBI)

Depending on the cause, brain injury can be broadly classified as Traumatic Brain Injury or TBI and non-traumatic brain injury.



**Figure 1.1 :** According to Brain Injury Association of Massachusetts, depending on the amount of force that impacts the head, the injury can affect one or more functional areas of the brain.

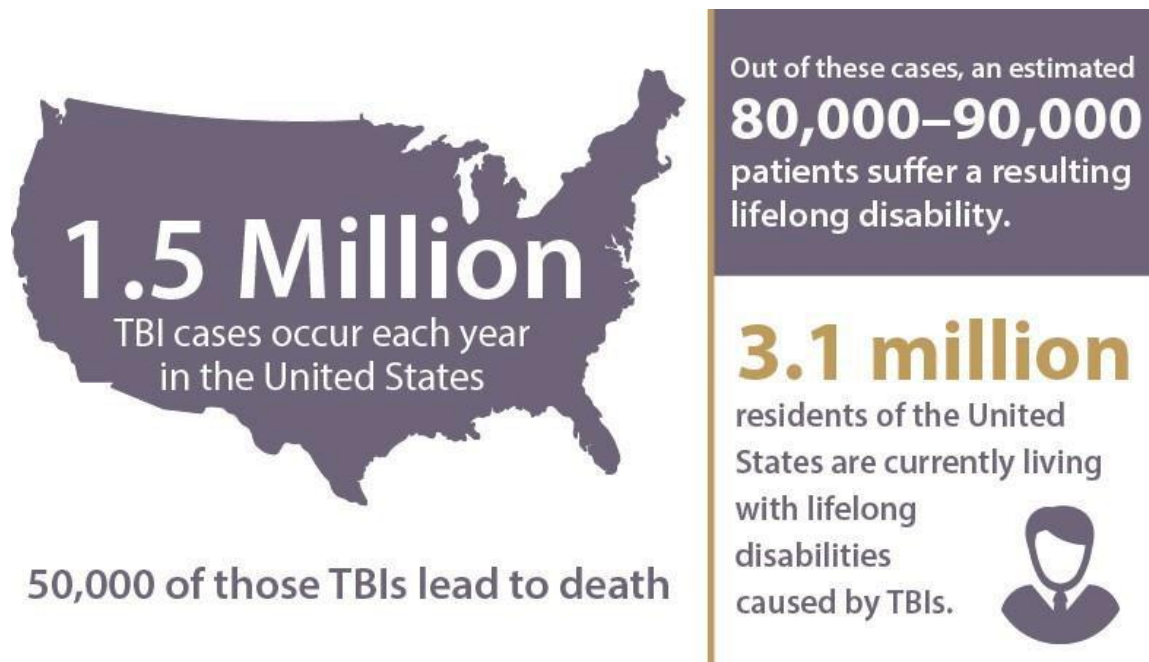
TBI happens when a sudden, violent blow jolts the head or when an object pierces the skull and penetrates brain tissue which results into brain damage and ultimately permanent disability and/or death.



**Figure 1.2** Traumatic brain injury is caused by an external physical force that may produce a diminishes or altered state of consciousness and which results in an impairment of cognitive abilities or physical functioning. (North Dakota Brain Injury Network)

Source : [1]

According to the American Association of Neurological Surgeons, around 1.5 million TBI cases occur every year in US alone among which around 50,000 cases lead to death and estimated 80,000-90,000 causes lifelong disability. Approximately 3.1 million people currently living with a disability in the US (The Brain Injury Association of America or BIAA).

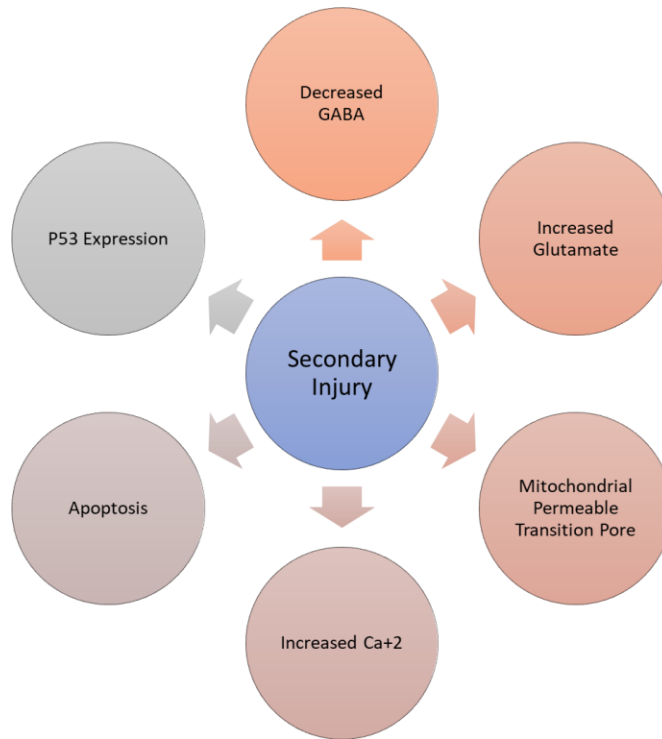


**Figure 1.3** The American Association of Neurological Surgeons reports that around 1.5 million TBI cases occur each year in the United States, around 50000 of these lead to death.

Source : [2]

Acute TBI can be classified into two injury phases - primary and secondary[3]. Primary injury is the direct injury following the trauma. This phase is characterized by concussion, direct neural damage, herniation of important brain structures which finally leads to secondary injury through progressive biochemical interactions. Primary injury cannot be avoided but the secondary injury can be contained to a certain limit by taking precautionary measures and with proper treatment. A cascade of biochemical processes is involved in the secondary phase - rapid release of excitotoxins like glutamate and aspartate which in turn act on N-methyl-D-aspartate or NMDA channel altering permeability of cell membrane, increase in intracellular calcium and calcium-modulated proteins like calcineurin and calmodulin. NMDA activation also increases the sodium level in intracellular spaces. All together helps in fragmentation of the axon [4]. Excessive release of potassium from cells are absorbed by astrocytes restricts the ionic imbalance in brain cells causing swelling and death of cells. Secondary injury in prolong

-ed and not limited to brain cells, also causes multiple organ failure. Major biochemical changes after brain injury involves growth factors, catecholamines, neurokinins, cytokines, and



chemokines.

**Figure 1.4** : TBI is a modulator of various neurological signaling pathway. The above image is showing the chemical changes and possible targets in the secondary injury post TBI.  
Source : [5]

### 1.3 Uses of Lithium as a drug

Lithium (Li) silvery-white alkaline chemical material with atomic mass number 3, is the lightest metal known which also lightens your mood. Lithium has many uses - as a chemical its most popular use is in manufacturing of batteries and aircrafts; as a drug, it is widely used for treatment for bipolar disorder to stabilize the wild mood swings [6]. Lithium is used to treat manic episodes of bipolar disorders which includes hyperactivity, poor judgement, insomnia, aggression, and anger. It helps to lessen the intensity of manic episodes of this illness. It is also used for schizophrenia disorder and major depressive disorder (MDD), only after failure of other drugs and therapy only.

<b>Molecular mass</b>	7 Da
<b>Protein binding</b>	0%
<b>Oral bioavailability</b>	Immediate release 95% - 100% Modified release 60% - 90%
<b>Therapeutic serum concentration</b>	0.6-1.2 mEq/L
<b>Half-life (therapeutic)</b>	12 – 27 hours
<b>Toxic dose (acute poisoning)</b>	>1g elemental Li

**Figure 1.5** Physiochemical and Toxicokinetic Properties of Lithium

Source : [7]

Despite Lithium's huge popularity, the physiologic role and its mechanism are not well understood [8]. Lithium's physiologic role is unknown, and its mechanism is not well understood; however, some proposed mechanisms include [9]:

- Modulation of neurotransmission - Dopamine pathway[9-11]:

In the nervous system dopamine works as an excitatory neurotransmitter which plays important roles in motor control, memory, reward, executive functions, sleep, learning etc. The cyclical dysregulation theory [12, 13] postulates that the elevation of dopamine neurotransmission during mania causes downregulation of dopamine receptors which ultimately results in decreasing dopamine neurotransmission associated with clinical depression. Postsynaptic activation of dopamine is mediated by G-proteins (stimulates second messenger systems like adenylyl cyclase, cAMP) coupled receptors or GPCR. Lithium decreases presynaptic dopamine activity and inactivates the subunits of dopamine associated G proteins, thus maintaining the equilibrium between active and inactive subunits. This mechanism of Lithium helps in reducing excitatory neurotransmission in the brain.

- Modulating neurotransmission - Glutamate pathway [9, 10, 14]:

Glutamate, another excitatory neurotransmitter, causes excitotoxicity in increased levels. NMDA is a subtype of glutamate receptor which can be acutely simulated by lithium, thus increasing glutamate availability in postsynaptic neurons. After chronic administration, lithium enhances inhibitory neurotransmission by downregulating NMDA receptors which in turn inhibits myoinositol second messenger system. The myoinositol (MI) pathway



maintains signal efficiency by production of two postsynaptic second messenger system pathways on Inositol triphosphate (IP3) and Diacylglycerol (DAG) to modulate neurotransmission and regulate gene expression. Indirectly, lithium reduces glutamate activity by decreasing dopamine activity.

- Modulating neurotransmission - GABA pathway [10, 14]:

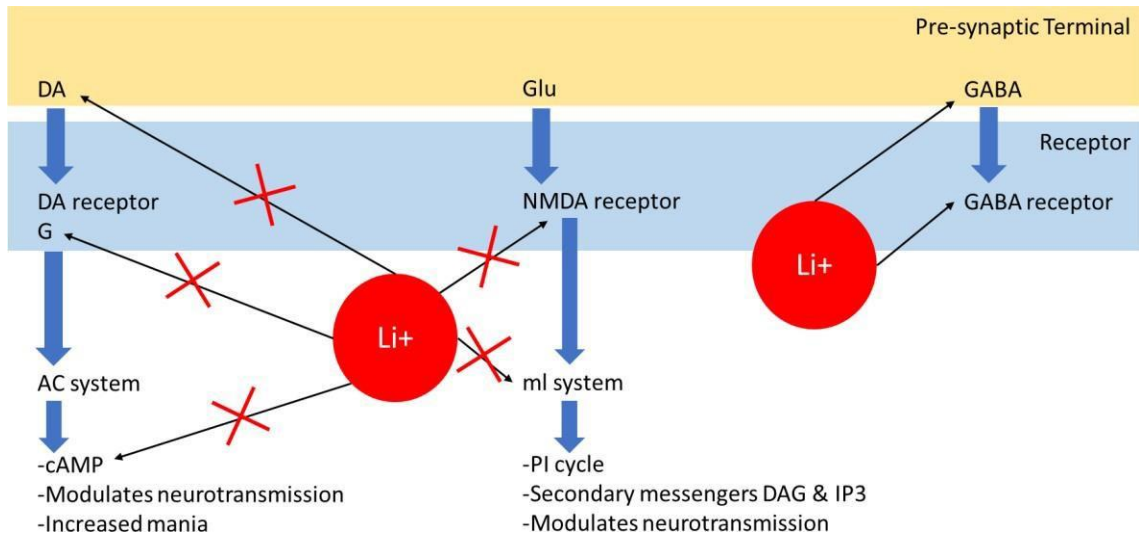
GABA is an inhibitory neurotransmitter which indirectly modulates dopamine and glutamate levels in the nervous system. Bipolar patients show deficiency or lower levels of GABA, thus postulating that GABA can result in excitatory toxicity. Lithium increases GABA level in cerebrospinal fluid by facilitating GABA release at presynaptic level and upregulating GABA-B receptors at postsynaptic level. Increased level of GABA reduces glutamate and downregulates NMDA receptors.

- Modulating neurotransmission - Myoinositol pathway [14]:

Phosphoinositides (PI) are precursors for many molecules that play an important role in CNS neurotransmission. Phosphoinositide helps in production of myoinositol with the help of ImPase and IPPase, which are then used to synthesize PIs. Myoinositol levels are found to be increased in patients with mania and depression. Lithium inhibits ImPase and IPPase reducing myoinositol level and this decreases the production of PI. Myoinositol levels are unaffected by lithium in euthymic patients, proving that lithium only inhibits myoinositol when in excess.

- Modulating gene expression - cellular pathways [14]:
  - a. Protein Kinase C (PKC), Myristoylated Alanine-Rich C Kinase Substrate (MARCKS) and Glycogen Synthase Kinase 3 (GSK3) are linked with mania. Lithium inhibits PKC and its downstream target MARCKS which has antimanic effects. GSK -3 is an enzyme which is involved in gene transcription and synaptic elasticity. GSK-3 activates due to chronic stress like mania. Lithium has shown inhibitory effects on GSK-3 thus maintaining the balance of brain chemistry.
  - b. Lithium also inhibits the sodium-inositol transporter at the cellular level which reduces availability of myoinositol.
  - c. Consistent finding of elevation of intracellular calcium concentration which plays role in neurotransmission, gene expression, metabolism, and cellular integrity, may mark an illness state. Myoinositol pathway initiates PKC activation and Intracellular calcium release. Lithium inhibits the PI production which in turn decreases the intracellular calcium level and reduces excitatory toxicity.
  
- Stimulating serotonin release from the hippocampus [14]:
 

Lack of serotonin causes depression. Numerous in vitro and in vivo studies have shown that lithium stimulates release of serotonin (5-hydroxytryptamine, 5-HT) by alteration of 5-HT auto receptors producing anti-depressant effects.



**Figure 1.6** Effects of lithium at microscopic level on neurotransmission and intracellular and molecular pathways  
Source : [15]

### 1.4 Pharmacokinetics of Lithium:

Lithium does not show any clinically significant protein binding properties. It is excreted almost entirely by the kidneys, with small amounts of leak in sweat and feces. Filtered lithium is reabsorbed substantially to make the clearance of lithium one fifth of clearance of creatinine. The rate of reabsorption is 70-80 percent in the proximal tubule of the kidney. Depending on age and Glomerular Filtration Rate (GFR), the elimination half-life of lithium is 18-24 hours approximately. Lithium does not get metabolized in the liver

**CHAPTER 2**  
**AIM 1: DETERMINATION OF OPTIMUM DOSAGE OF LITHIUM FOR ANIMAL  
USAGE**

**2.1 Hypothesis Approach**

Lithium toxicity or Lithium overdose is the condition of having too much Lithium. It can occur due to excessive intake or decreased excretion. Lithium, absorbable by the gastrointestinal tract, is distributed to the body mostly in the kidney, thyroid, and bone but it is exclusively excreted by kidney and sweat. Chronic Lithium toxicity leads to severe complications like renal toxicity or failure, hypothyroidism and in rare cases it causes coma, heart failure or peripheral cardiovascular collapse, seizures, and death. The first aim of this literature is to determine safe dosage of Lithium for mammalian use.

**2.2 Lithium Toxicity**

Excessive intake or impaired excretion results in lithium accumulation which finally leads to Lithium toxicity. At therapeutic levels of 1 mM or less, lithium does not have significant myocardial effects. In 1985, Baandrup examined myocardial changes in rats with lithium-induced uremia [16]. The rats were treated for 6–12 weeks with lithium. They found that rats with uremic changes showed evidence of cardiac damage with infiltration of lymphocytes, histiocytes, and plasma cells. These changes were not present in rats that were not uremic. However, the changes were reversible. The authors concluded that presence of chronic kidney damage and lithium treatment together can lead to reversible myocardial changes.

Prolonged exposures to a serum lithium level of 2 mM or greater may lead to liver and renal damage. Serum alcohol dehydrogenase may be increased in patients that take lithium and

have alcohol dependence. In rats, superoxide dismutase (SOD) and glutathione peroxidase (Gpx) activity increased in the liver but not in the brain. Regular monitoring of serum concentrations of lithium is essential, particularly in patients with preexisting neurological illness, older age, or receiving medications that may interact with lithium.

Long-lasting lithium intoxication can produce irreversible brain damage. Cerebellar symptoms, dementia, parkinsonian syndromes, choreoathetosis, brain stem syndromes, and other neuropathies may persist after stopping lithium treatment. Electroencephalographic changes may detect lithium intoxication despite moderate serum levels.

### **2.3 Levels of Lithium Toxicity**

There is a very narrow gap between the therapeutic dosage and the toxic dosage of lithium.

There are three stages of lithium toxicity.

- Acute poisoning in previously untreated patients:

Predominantly affects central nervous system (CNS). It is characterized by mild symptoms despite elevated plasma lithium level. However clinical features vary with the specific pattern of poisoning, symptoms may be minor. The delayed diffusion of lithium to the brain causes the absence or delayed symptoms. Mild lithium poisoning includes drowsiness, nausea, vomiting, tremor, hyper-reflexia, agitation, muscle weakness and ataxia. More prominent symptoms are stupor, rigidity, hypertonia, and hypertension.

- Acute-on-chronic poisoning in previously treated patients: Due to overdose.

- Chronic poisoning in treated patients:

It is caused by the progressive lithium accumulation due to renal dysfunction, low sodium intake and drug-drug interactions. It may result in severe neurological symptoms with plasma lithium level just above the therapeutic range. In most severe cases, it leads to convulsions, myoclonus, cardiopulmonary collapse, and coma.

Serum lithium level is just a guide to the potential risk of lithium toxicity. The patient's history, clinical findings and kidney functions should be considered before reaching a diagnosis. As the distinction between these three stages are subtle, it can be considered as a progression of potentially severe overdose.

Severity of lithium poisoning can only be determined by presence of gastrointestinal symptoms. These symptoms are prominent in acute poisoning but almost absent in chronic toxicities.

The stage of lithium toxicity can be determined by the gastrointestinal symptoms exclusively which are prominent in acute poisoning and almost absent in chronic toxication.

**Table 2.1** Lithium toxicity effects at different toxicity level

<b>SYMPTOMS</b>	<b>ACUTE TOXICITY</b>	<b>CHRONIC TOXICITY</b>
GI (NAUSEA, VOMITING, DIARRHEA)	42%	20%
CNS (SEIZURES)	delayed	Common > 2.mmol/L
RENAL	usually not significant	universal
ECG	normal	QT prolongation usual
THYROID	none	Hypothyroidism 20%
RECOVERY	usual, rapid	Disability 10% delayed

## 2.4 Methods and Material

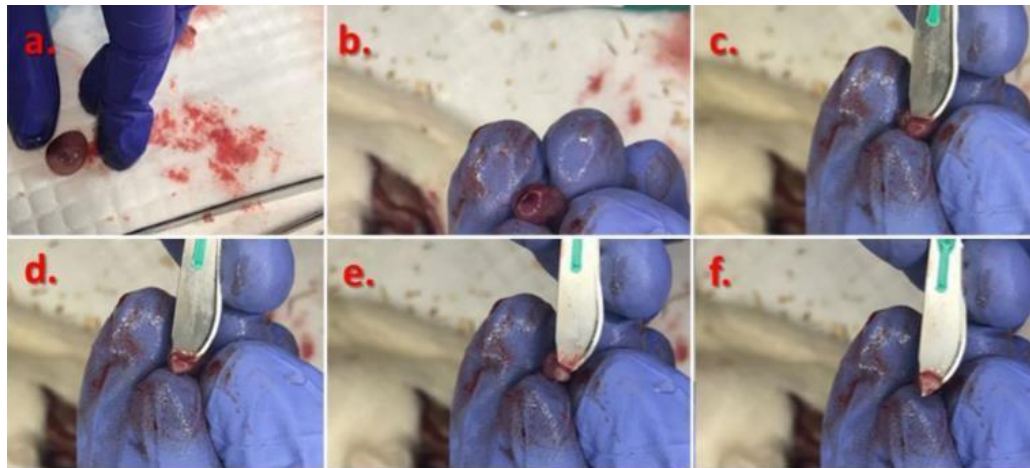
For this experiment, neuronal cells were isolated from rat embryos. A Sprague Dawley E17 pregnant rat was anesthetized with a combination of ketamine and xylazine according to the recommendations and guidelines of the Institutional Animal Care and Use Committee; after which the rat was pinned down and the abdomen was cut to expose the fetuses. Fetuses were removed one at a time, with the rest remaining in the live mother; the embryo was then extracted from the removed fetus. Holding the embryo in an upright position with the anterior portion of the head faced away, an incision was made along the midline of the skull with a scalpel. Next the skull was peeled back, and the cortices teased out. Successful extraction can be confirmed if the removed tissue has a kidney shape (Figure 3.1). Extracted hemispheres were placed in L-15 media (Thermo Fisher Scientific) on ice, finally meninges were removed. The entire extraction process, from administering anesthesia to removing meninges, was done in less than 10 mins. If many cells were needed, extractions were done by two or more technicians simultaneously to keep total extraction time under 10 mins. One pup with both cortices removed produced almost 2.5 million cells. The whole enzymatic tissue digestion, neuronal isolation techniques, cell count, and cell plating were performed as per our standard laboratory protocols.

Neuronal cells were isolated from rat embryos and plated on 12mm poly-D-lysine coverslips (Corning; Teterboro, NJ, USA) at a density of 50,000cells/cm<sup>2</sup> in cortical media. The cortical media was comprised of Neurobasal medium (Thermo Fisher Scientific; Fair Lawn, NJ, USA) with 1% Penicillin/Streptomycin (Thermo Fisher Scientific), 2% 50X B-27 Supplement (Gibco, under Thermo Fisher Scientific), and 0.2% L-Glutamine (Sigma-Aldrich; MO, USA). 24hrs after plating, 2 mL of was removed and replaced with 2 mL fresh media 12



days later, cells were treated with 100 mM glutamate for 24 hrs. The next day these cells were treated with different concentrations of Li (0.05 mM, 0.5mM, 1mM and 5mM respectively) again for 24 hours. Finally, these cells were observed under the microscope and analyzed for metabolic activity with an MTT assay. After more than 14 days in culture they lose quality and are no longer appropriate for experimentation.

MTT assay quantifies level of metabolic activity in cells in culture and has been widely used to assess cell viability. It is a colorimetric reaction that can be easily from cell monolayers plated in the wells. Living cells reduce yellow tetrazole into purple formazan. For MTT assay supernatant was aspirated from each well. The plate was incubated at 37 degree Celsius for 30-45 minutes after adding 100 ul of MTT solution (5 mg/ml MTT solution in 10% FBS in PBS) into each well. After incubation, the MTT solution was aspirated from each well. Before putting it into plate reader, the plate was kept at temperature for 15 minutes. Plate reader was set at 490 nm.



**Figure 2.1** Step-by-step procedure of neuronal dissection from freshly extracted fetus. a) Fetus removed from its embryonic sac. b) The embryo held with the brain facing up. The brain of an E17 pup has developed enough while the skull is thin enough so that the hemispheres can be easily distinguished. c) Incision along the midline of the skull being careful not to puncture the brain. d) Peeling back of the skull. e) Gentle back and forth teasing of the cortices from the brain. f) The final kidney shaped tissue extracts.

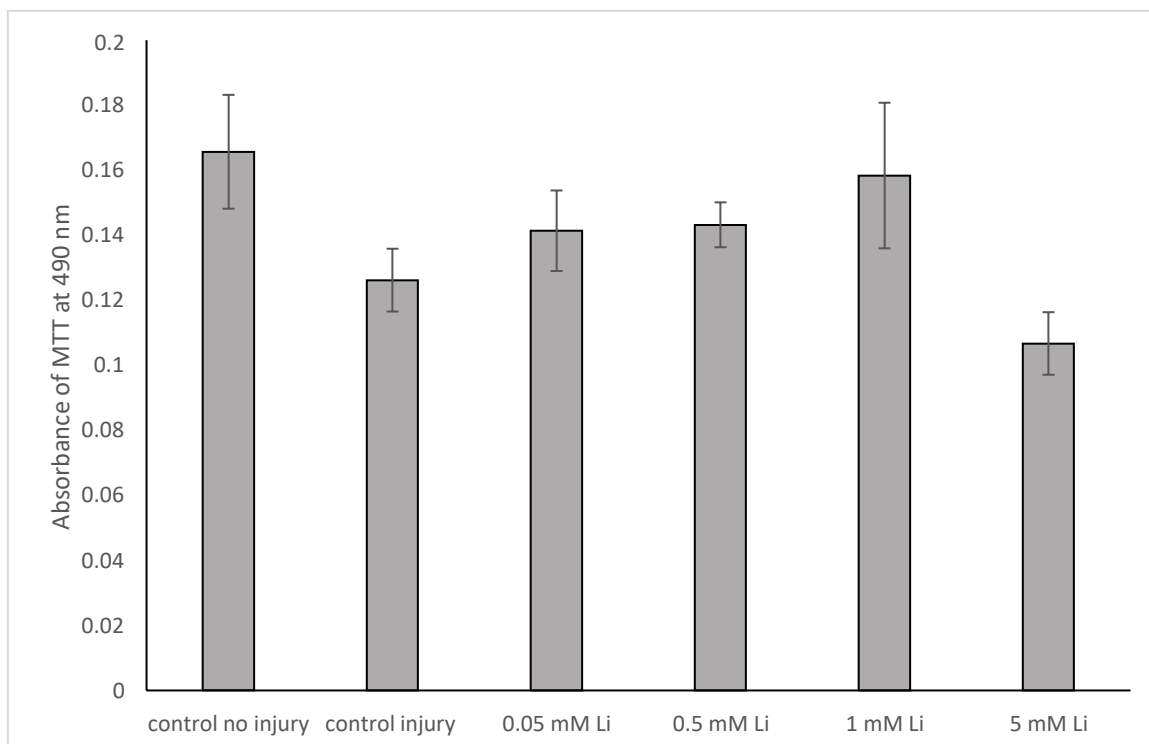
Source : [17]

## 2.5 Results and Analysis

**Table 2.2** MTT Assay - Absorbance of Lithium by cortical neural cells

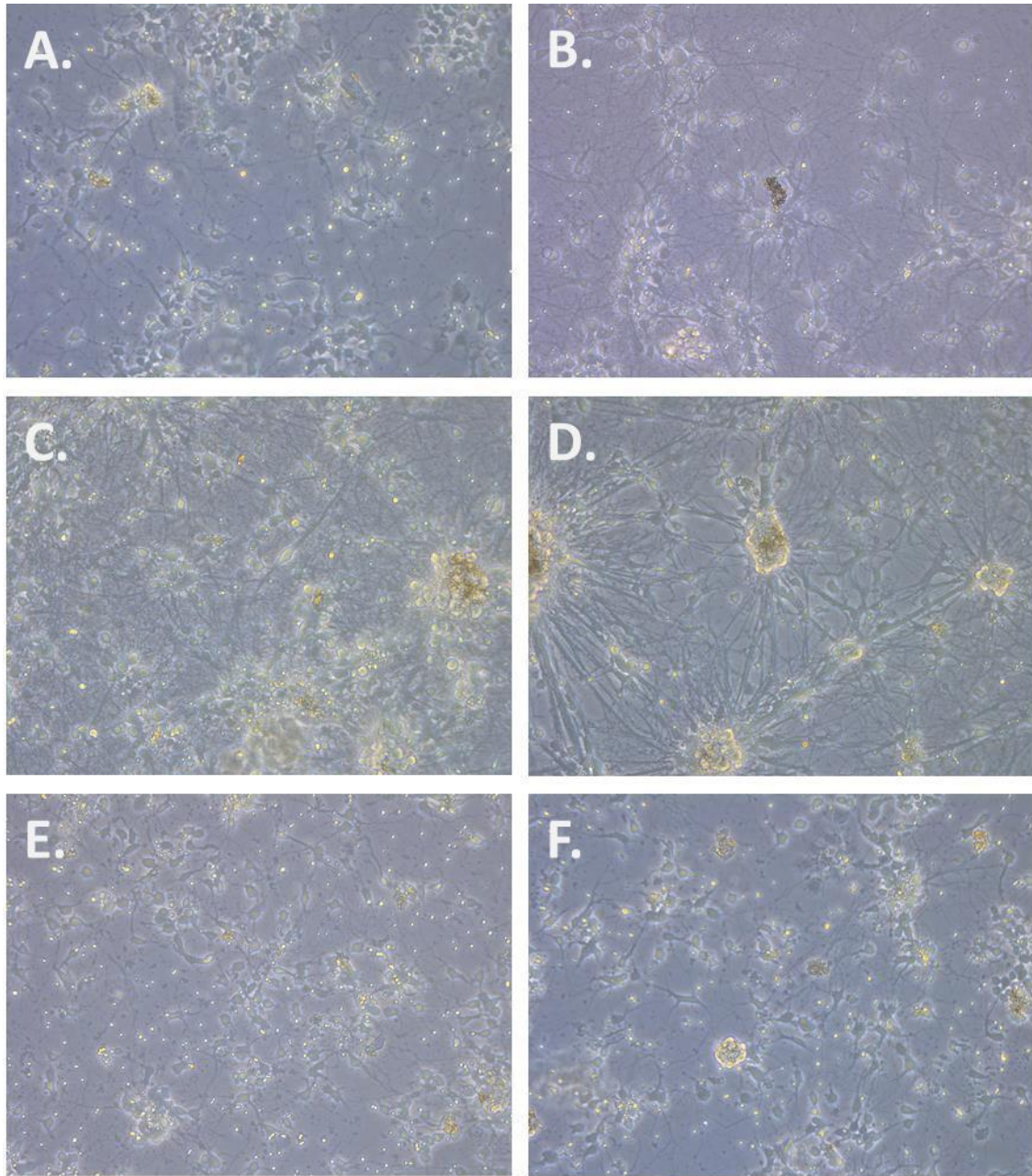
<b>Condition</b>	<b>Absorbance of lithium by cortical neural cells</b>	<b>Standard error</b>
Control (no treatment with L-glutamate and LiCl)	0.16565	0.01752
Injury (treated with 100 mM L-glutamate but no LiCl treatment)	0.16565	0.01833
Treated with 100 mL L-glutamate and 0.05 mM LiCl	0.1414	0.01858
Treated with 100 mL L-glutamate and 0.5 mM LiCl	0.1432	0.01453
Treated with 100 mL L-glutamate and 1 mM LiCl	0.15836	0.01643
Treated with 100 mL L-glutamate and 5 mM LiCl	0.10671	0.00686

Primary culture of neuronal cells represented a nearly homogenous population of excitatory neurons. After 24 hours of exposure to toxic levels of 100 mM glutamate, the cells began showing signs of neurodegeneration. This was characterized by fragmentation of axonal projections and shrinkage of dendritic arborizations (Fig. 2.3b). On the other hand, the cells, categorized in several groups and treated with 0.05 mM/L, 0.5 mM/L, 1 mM/L and 5 mM/L along with glutamate showed significantly lower numbers of dead cells (Fig. 2.2). In addition, many axons remained intact and there were few signs of dendrite retraction (Fig. 2.3c-f). Incubation of culture for 24 hours, marked the lowest number of dead cells at 1 mM/L lithium concentration (Fig. 2.2). The number of live cells at the primary culture and the glutamate and 1 mM/L lithium treated culture were not significantly different. Neuronal cells appeared similar in structure to those in the no lithium control (Fig. 2.3a). Therefore, 1 mM of lithium was found to be the optimal concentration for inducing neurotoxicity recovery. The MTT assay demonstrated the difference between the number of cells with different conditions.



**Figure 2.2** Bar graph of cell metabolic activity results. 1 M produced activity closest to the control and was chosen as the working concentration for my experiments. Cell were cultured in a 96 well plate for 12 days before treatment. Cells were treated with a range of 0.05 mM-5 mM lithium in media for 24 hours prior to metabolic activity analysis with MTT assay. Top: Results obtained from the plate reader. 200  $\mu$ L of solution was measured for each condition. Bottom: The percent difference from control. The relative difference of each condition from the no injury control was obtained by taking the difference, dividing by the control, then multiplying by 100.

Neuronal cell metabolic activity did not differ significantly among amount of lithium treatment after injury (one-way ANOVA,  $F(5,42) = 2.31$ ,  $N = 8$ ,  $\eta^2 = 0.11$ ,  $p = 0.06$ ). Post-hoc t-tests reveal no statistical significance difference between the control and 1 mM groups ( $t(8) = -0.26$ ,  $p = 0.801$ ), control and 0.05 mM group ( $t(14) = -1.13$ ,  $p = 0.278$ ), control and 0.5 mM group ( $t(14) = -1.19$ ,  $p = 0.253$ ), control and 1 mM group ( $t(14) = -0.26$ ,  $p = 0.801$ ), control and 5 mM group ( $t(14) = -2.95$ ,  $p = 0.011$ ), injury and 0.05 mM group ( $t(14) = 0.97$ ,  $p = 0.350$ ), injury and 0.5 mM group ( $t(14) = 1.43$ ,  $p = 0.175$ ), , injury and 5 mM group ( $t(14) = -1.43$ ,  $p = 0.176$ ), 0.5 mM and 0.05 mM group ( $t(14) = -0.13$ ,  $p = 0.901$ ), 1 mM and 0.05 mM group ( $t(14) = -0.66$ ,  $p = 0.518$ ), 5 mM and 0.05 mM group ( $t(14) = 2.21$ ,  $p = 0.044$ ), 1 mM and 0.5 mM group ( $t(14) = -0.65$ ,  $p = 0.528$ ), 5 mM and 0.5 mM group ( $t(14) = 3.08$ ,  $p = 0.008$ ), 1 mM and 5 mM group ( $t(14) = 2.12$ ,  $p = 0.052$ ). However, statistical significance difference was found between the control and injury group ( $t(8) = 3.59$ ,  $p < 0.003$ ) and between injury and 1 mM group ( $t(14) = 3.77$ ,  $p = 0.002$ ). 1 mM lithium was chosen as the working concentration because this concentration produced cellular activity closest to the no injury control.



**Figure 2.3 :** The figures above represent neurons in cell culture study with and without glutamate-induced injury and after treatment with LiCl at different concentrations.  
A) Neural cell culture without any treatment. B) Neural cell culture with glutamate treatment. C) Neural Cell culture with 0.05 mM LiCl. D) With glutamate and 0.5 mM LiCl. E) With glutamate and 1 mM LiCl. F) With glutamate and 5 mM LiCl. Magnification is 20X for all images.

## 2.6 Discussion

The above experiment demonstrated that at 0.05 mM and 0.5 mM concentration, lithium protecting neurons against glutamate-induced toxicity. But at 1 mM concentration, lithium is showing maximal effect, the number of neurons in the culture treated with glutamate and lithium is closest to the culture without any treatment. In this concentration, neurons behaved like neurons without injury or lithium because they had similar levels of metabolic activity and similar structural integrity, i.e., long, intact, and thick axon projections as well as undisturbed dendritic arbors. Thus, protection was observed at 0.05 mM and 0.05 mM, however significant protection was achieved at 1 mM (Fig 2.3). This experiment also showed that at a concentration of 5 mM lithium, it loses its neuroprotective action. From this study, I have come into conclusion that the lithium achieves maximal neuroprotectivity at 1 mM concentration and also lithium has a very narrow therapeutic range and above that level, lithium loses its neuroprotective nature and becomes toxic. Quantification of neuronal survival by MTT assay revealed neuroprotectivity of lithium is unchanged while the glutamate concentration that induced the injury remains the same. The large differences in standard errors between replicas prevented the desired concentration from being statistically significant (Fig 2.2).

**CHAPTER 3**  
**AIM 2: HEALING EFFECTS OF LITHIUM AFTER MILD TRAUMATIC BRAIN INJURY**

**3.1 Hypothesis Approach**

Recent studies demonstrate that Lithium has robust neuroprotective effects. It is reported that lithium protects neural cells against apoptosis induced by a variety of insults, for example, deprivation of high potassium, withdrawal of growth factors on cultured neurons and neutrally related cells. The mechanism of lithium for neuroprotective effects are not clear yet, but cellular and molecular studies suggest the neuroprotective mechanism against glutamate excitotoxicity due to inhibition of N-methyl-D-aspartate (NMDA) receptor activity. This literature observes the healing effect or neuroprotective effect of Lithium by running histology on the blood samples taken from time dependently lithium treated rats after induced mild traumatic injury.

**3.2 Neuroprotective Effects of Lithium**

From the previous study, lithium has shown neuroprotective effect at a narrow range of dosage on neurons against glutamate-induced toxicity. This result is also supported by several in vitro and in vivo studies which documented a neuroprotective effect of lithium against various noxious insults by preventing apoptosis through multiple mechanisms [18]. In the lithium-pilocarpine model [19], a long-standing model of status epilepticus, Wister rats were injected with lithium (3 mEq/kg) intraperitoneally 19 - 24 hours prior to the administration of pilocarpine (30-60 mg/kg) to induce consistent status epilepticus (SE). The mortality rate of rats who were given pilocarpine combined with lithium is very low

compared to the rats who were subjected to a high dosage of pilocarpine without lithium [20].

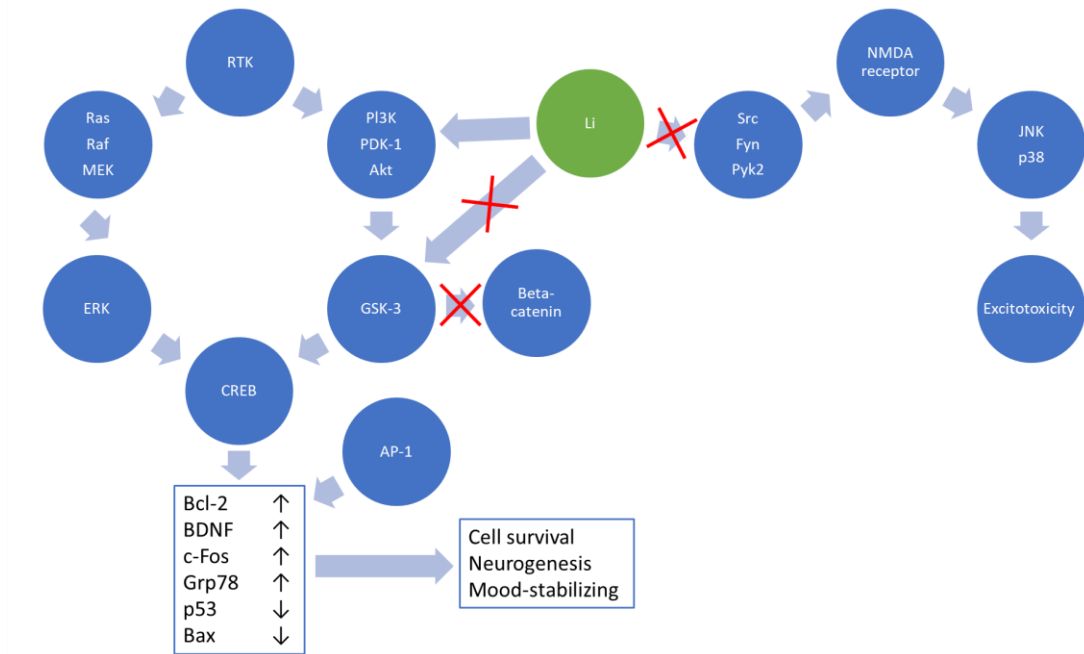
Another study by Chen and Chuang [21] showed that the expression of p53 and Bcl-2, by lithium treatment, causes neuronal survival. Chen et al [22]., showed the chronic administration of two structurally dissimilar mood stabilizing agents, lithium, and valproate results in increased Bcl-2 levels in the cortex, with beneficial neuroprotective effects. High levels of Bcl-2 may be due to the inhibition of GSK-3 which is caused by Lithium. Aside from the antiapoptotic effect of Bcl-2, it stimulates the regeneration of axons post injury [23].

At the cellular level, lithium shows protective quality against neuronal apoptosis and glutamate excitotoxicity [24]. Lithium at a low dosage protects cerebellar neurons against glutamate excitotoxicity by inhibition of NMDA receptor mediated calcium influx. Study by [25]has shown that glutamate excitotoxicity was blocked by NMDA receptor antagonists(MK-801 and AP5) but not by non-NMDA receptor antagonist (NBQX) which supports the theory, glutamate induced toxicity is exclusively dependent on NMDA receptor subtype. Also, MTT assay quantifies neuronal survival in presence of lithium is independent of glutamate concentration [25] and is due to pre-treatment with 1mM LiCl.

GSK-3, a serine/threonine kinase, plays pivotal role in several cellular processes like gene transcription, cell apoptosis, glycogen synthesis and directly regulates several neurotransmitter systems like dopaminergic, glutamatergic, serotonergic, and cholinergic. Evidence shows that inhibition of GSK-3 by dose-dependent lithium treatment is a result of inhibition of m-RNA transcription [26].



According to the inositol depletion hypothesis [26], lithium also could exert its therapeutic effects through the phosphatidylinositol (PI) pathway by direct inhibition of IMP and inositol polyphosphate-1 activity associated with modulation of GSK-3.



**Figure 3.1** The figure depicts several pathways of neuroprotective mechanisms of lithium. Lithium downregulate GSK-3 activity by directly inhibiting ATP/Mg<sup>2+</sup> dependent catalytic activity of GSK-3 and via Ser-phosphorylation of GSK-3, several factors including PI3K/Akt pathway which can be activated by lithium. By upregulating phosphorylation of NMDA receptors, lithium gives protection against glutamate-induced excitotoxicity. These lithium induced events lead to changes in transcriptional factors like CREB, neuroprotective genes (Bcl-2 and BDNF).

Source : [27]

### 3.3 Methods and Materials

6-8 weeks old male Sprague-Dawley rats were purchased from Charles River laboratory (Wilmington, MA). Animals were maintained in sterile cages under pathogen free conditions in accordance with institutional ethical guidelines for care of laboratory guidelines, National Institute of Health guidelines and the Institutional Animal Care Use Committee, Rutgers University. Animals were randomly distributed in 4 experimental groups (3 rats/group): 1) Control (went under surgery but not injured nor administered Li), 2) Treated with 1mM LiCl, 3) Injured and 4) Injured with 1 mM LiCl. The 4th group were further categorized into 3 subgroups: a) 24 hours post injury with 1 mM LiCl treatment, b) 72 hours post injury with 1 mM LiCl treatment and c) 1-week post injury with 1 mM LiCl treatment. An optimal dose concentration of LiCl (mM) was determined from the previously performed dose dependent study on cortical neural cells.

After TBI, the human brain goes through several complex changes, which cannot be replicated by any single model under laboratory environment. But several preclinical models of TBI have been developed and successfully implemented to study its underlying pathology. The fluid percussion injury (FPI) model (Amsci Instruments) is the most commonly used animal model of TBI because of its capability to produce diffusion (midline FPI) and mixed (focal and diffuse; lateral FPI) which mimics very closely the pathology that are frequently seen following human TBI. Principle of FPI is based on generation of fluid pressure pulse on the intact dura through a craniotomy by striking the piston of a fluid reservoir with the help of a pendulum. FPI models can produce mild, moderate, and severe injury depending on the experiment condition and are easily scalable.

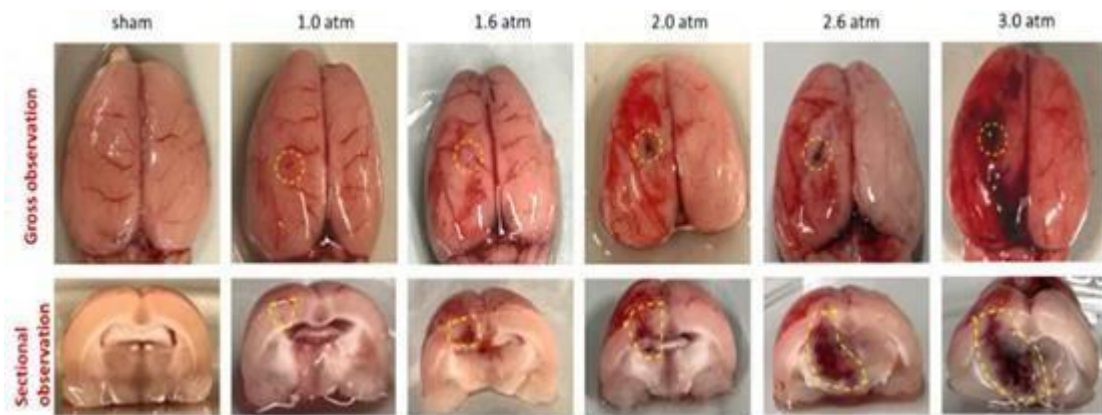
For this experiment, the rats were anesthetized with a mixture of ketamine and xylazine (10:1 (100mg/10mg/kg), 0.1 mL/100g) and placed in a stereo taxic frame before craniotomy. Rat brain craniotomy is performed as described by Alder J. et. al [28] On the left parietal skull, 2.5 mm lateral from the sagittal suture and 3.0 mm caudal from coronal suture, a 3 mm hole was made by drilling, maintaining the dura intact. A luer-lock hub was glued on the skull over the exposed dura with cyanoacrylate gel and secured by application of methyl-methacrylate (Henry Schein, Melville, NY, USA). 24 hours after surgery the rats were again anesthetized by isoflurane to receive lateral FPI (1.3 – 1.8 atm). 5 minutes after the injury, 1 mM LiCl (15 mg/500g) was injected intraperitoneally. The animals were observed for 24 hours, 72 hours and 1 week. Following FDA drug dosage guidelines, each lithium treated rat was given 15 mg/500kg LiCl/day everyday intraperitoneally till euthanization.

Animals were sacrificed after 24 hours, 72 hours and 1 week after the injury to harvest the brain tissue for analysis and collect blood samples. An hour before euthanization, rats were anesthetized as describes above to inject 1 uL of fluorescent label tracer (dextran-conjugated Fluorescein, 3000 MW) intracisternally into the blood parenchyma [29].

To collect the blood an incision was made on the left side of the chest to cut through the diaphragm, from the top of the sternum, and peeled back the chest to expose the heart. A 22-gauge needle was inserted attached to a syringe into a ventricle of the heart. Slowly the plunger was pulled off the syringe to withdraw the blood slowly to prevent the heart from collapsing. 1 mL of blood was collected and let it sit at room temperature for 1 hour for blood to clot. After centrifuging blood for 20 mins at 2200 RPM supernatant (serum) was collected into a tube (Serum can be stored in -20 C freezer). To measure fluorescent intensity (tracer) 25

uL serum was added into a 96 well plate and measured with a fluorescent plate reader at 521nm emission and 494nm excitation.

Animals were sacrificed after 24 hours, 72 hours and 1 week after the injury to harvest the brain tissue for analysis and collect blood samples. Brain tissues were immersed in 4% paraformaldehyde overnight, followed by cryoprotection in 30% sucrose in PBS until sink. Brain tissues were snap frozen in Tissue-Tek OCT compound (Thermo Scientific, Rockford, IL) and coronal sliced by Leica CM3050 cryostat into 20 $\mu$ m thickness sections.



**Figure 3.2** Gross observation of injured brain. Pathomorphological changes in rat brains at different pressure induced by Fluid Percussion Injury.  
Source : [30]

## **Histological Staining**

Brain tissue sections were stained with Cresyl Violet to count the cells. The Cresyl Violet is a basic dye, and is a common stain used in histology. Cresyl Violet is used to stain the neurons in the brain and spinal cord.

**Chemicals needed** : 0.1% Cresyl Violet Acetate; Ethanol in different concentration - 30, 70, 90 and 100%; Xylene (Fisher Scientific - catalog #HC700 - 1 Gal); DPX mountant (Fluka Biochemicals - catalog #44581 - 100 ml); Glacial Acetic Acid; Distilled water **Solutions** : To make Cresyl Violet stain - 500 ml distilled water, 0.5 g cresyl acetate, 1.25 ml Glacial acetic acid (2.5 ml 100% GAA in 1 L of H<sub>2</sub>O); were stirred on heat (60 degrees Celsius) until majority of the crystals are dissolved. The solution was cooled down and filtered before every use.

**Staining procedure:** The brain sections were stained in 0.1% Cresyl Violet solution for 2 mins and then rinsed quickly in distilled water a few times. Then the slides were dipped into 30, 70, 90 and 100% ethyl alcohol respectively for 30 seconds each time. Then the slides were cleared in Xylene for 3 minutes before mounting with DPX mounting medium. **Imaging:** Whole brain tissue sections images were scanned (20x magnification) by Leica Aperio Versa 200 digital pathology grade slide scanner. Three regions (200X200 um) per tissue slices (2 slices per animal) in the side of injury (motor cortex) are selected to count the number of Cresyl violet labeled neurons using counter tool in ImageScope. Location and size of region was the same for each condition.

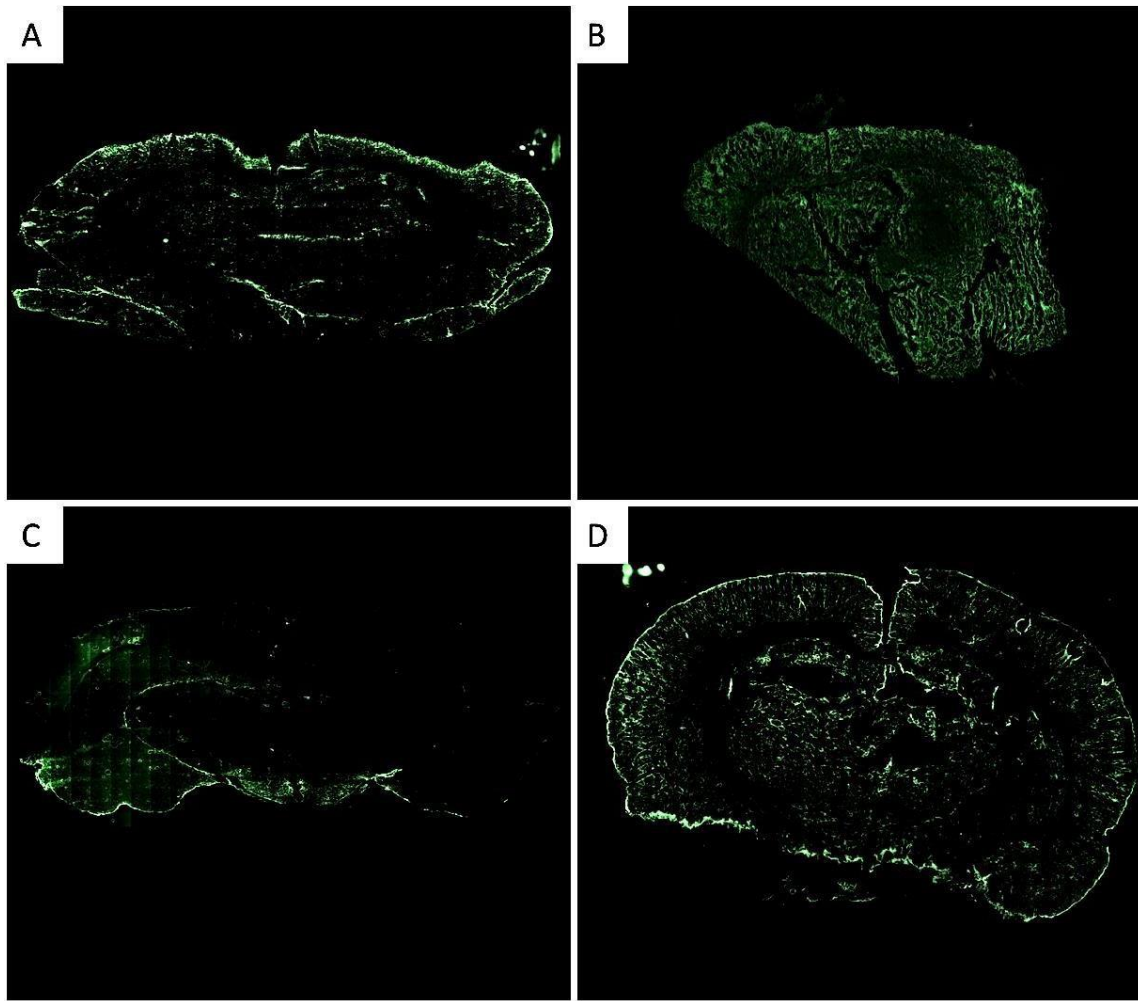
### 3.4 Results and Analysis

**Table 3.1** Experimental Design

<b>Group Number</b>	<b>Group Type</b>	<b>Numbers of animals</b>	<b>Time Interval</b>
<b>Group 1</b>	Pure Control without LiCl and without injury	3	24 hours
<b>Group 2</b>	Control with LiCl without injury	3	24 hours
<b>Group 3</b>	Control with injury and without LiCl	3	24 hours
<b>Group 4</b>	Injury with LiCl	9	a) 3 animals for 24 hours b) 3 animals for 72 hours c) 3 animals for 1 week

**Table 3.2** Absorbance values of tracer in rats that have undergone mild traumatic brain injury and lithium treatment.

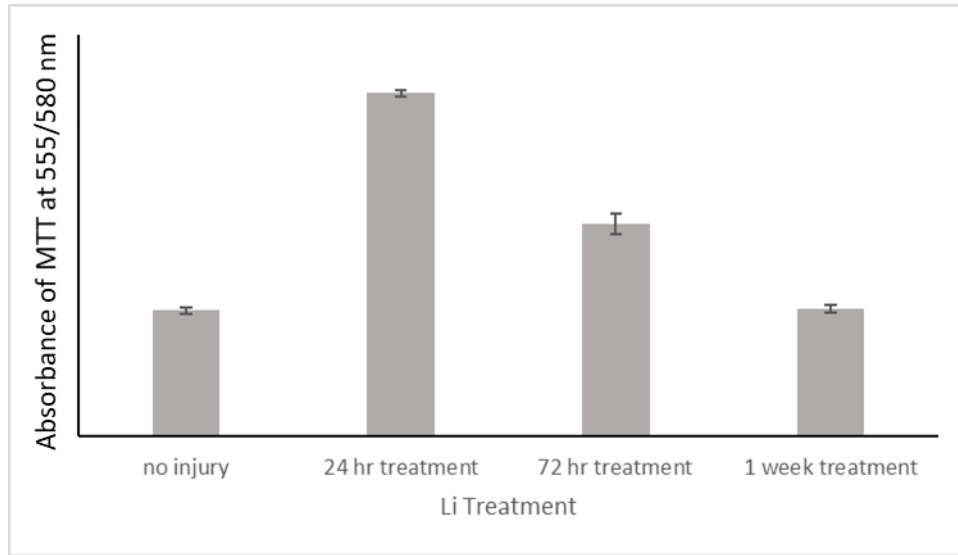
<b>Condition</b>	<b>Rat 1</b>	<b>Rat 2</b>	<b>Rat 3</b>	<b>Mean</b>
<b>Control + Li</b>	26358414	24247500	24611480	25072465
<b>24 hr after Injury + Li</b>	69528048	67351672	68337408	68405709
<b>72 hr after injury + Li</b>	45686524	42946336	38663728	42432196
<b>1 wk after injury + Li</b>	26482562	24598696	26316866	25799375



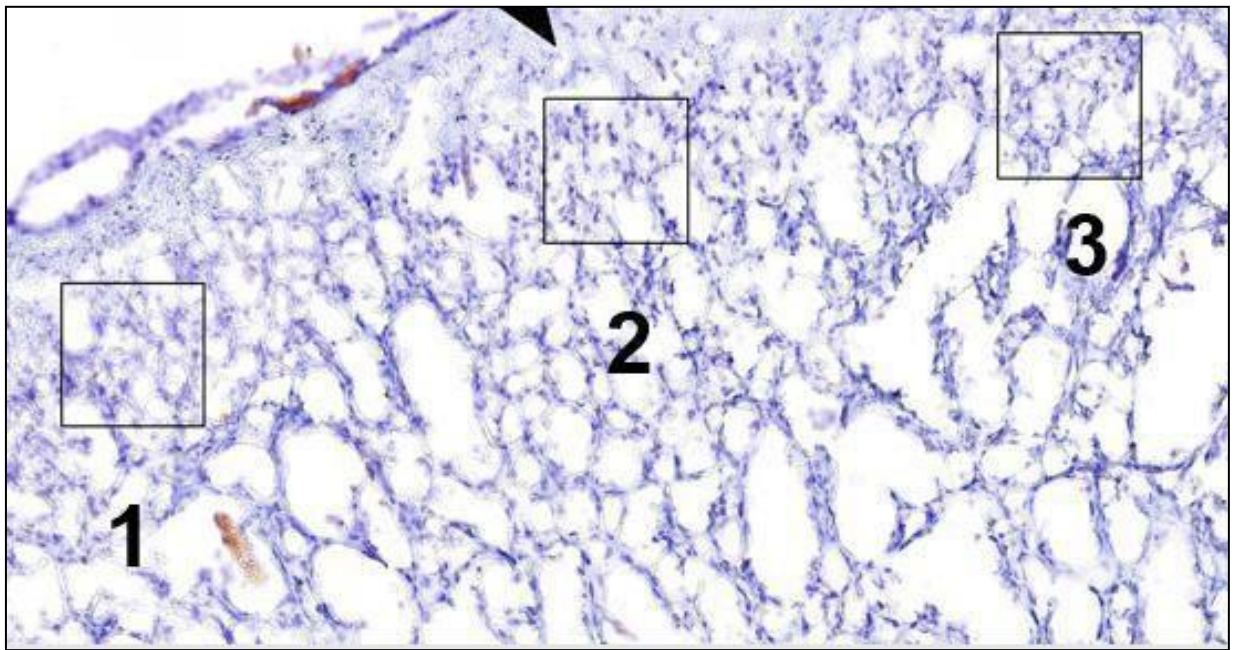
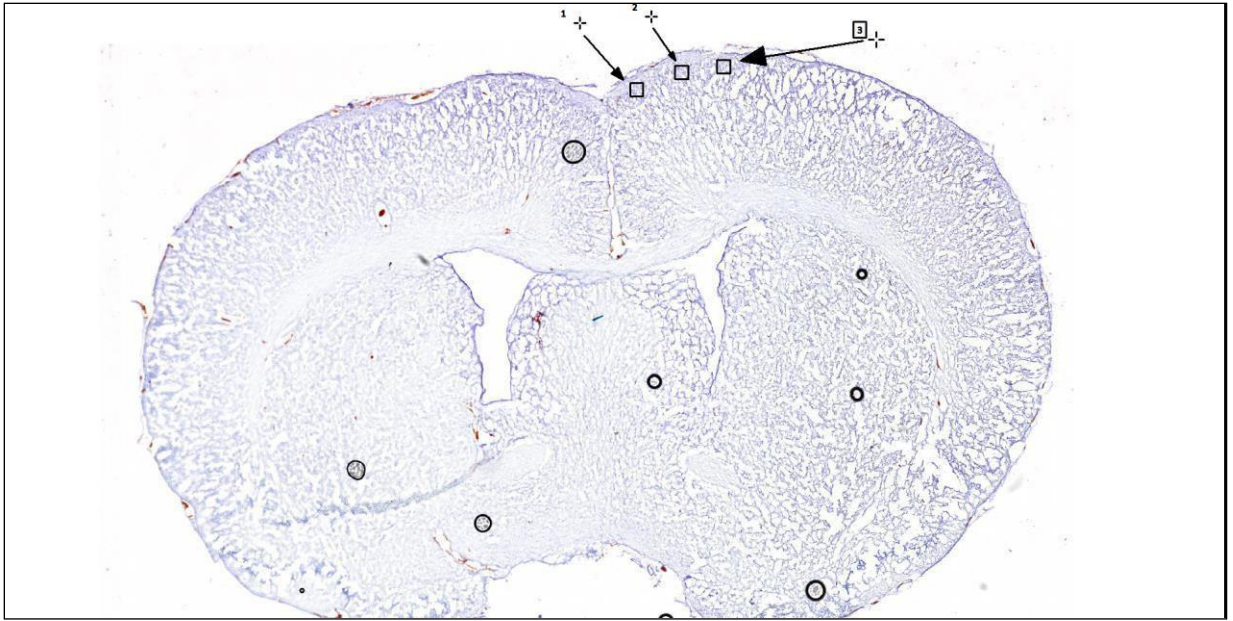
**Figure 3.3** : Tracer level in the brain sections with A) Control, B) Injury, C) 72 hours post-injury with LiCl, D)1week post-injury with LiCl.

Release of labeled tracer differed significantly among length of lithium treatment after injury (one-way ANOVA,  $F(3,8) = 307.7$ ,  $N = 3$ ,  $\eta^2 = 0.27$ ,  $p < 0.001$ ). Presence of tracer corresponds to the leakiness of the brain parenchyma. Post-hoc independent samples t- tests, with Bonferroni correction ( $\alpha$  adjusted to 0.008), revealed significant differences between the control+lithium and 24 hrs after injury+lithium groups ( $t(4) = 47.84$ ,  $p < 0.001$ ), control+lithium and 72 hrs after injury+lithium groups ( $t(4) = 8.09$ ,  $p = 0.001$ ), 24 hrs after injury+lithium and 72 hrs after injury+lithium groups ( $t(4) = 12.15$ ,  $p < 0.001$ ), 24 hrs after injury+lithium and 1 week after injury+lithium groups ( $t(4) = -48.92$ ,  $p < 0.001$ ), and 72 hrs after injury+lithium and 1 week after injury+lithium groups ( $t(4) = -7.81$ ,  $p = 0.001$ ) but not between the control+lithium and 1 week after injury+lithium groups ( $t(4) = 0.82$ ,  $p = 0.459$ ). This demonstrates that continual treatment with lithium for 1 week significantly improved the metabolic activity of the injured brain.

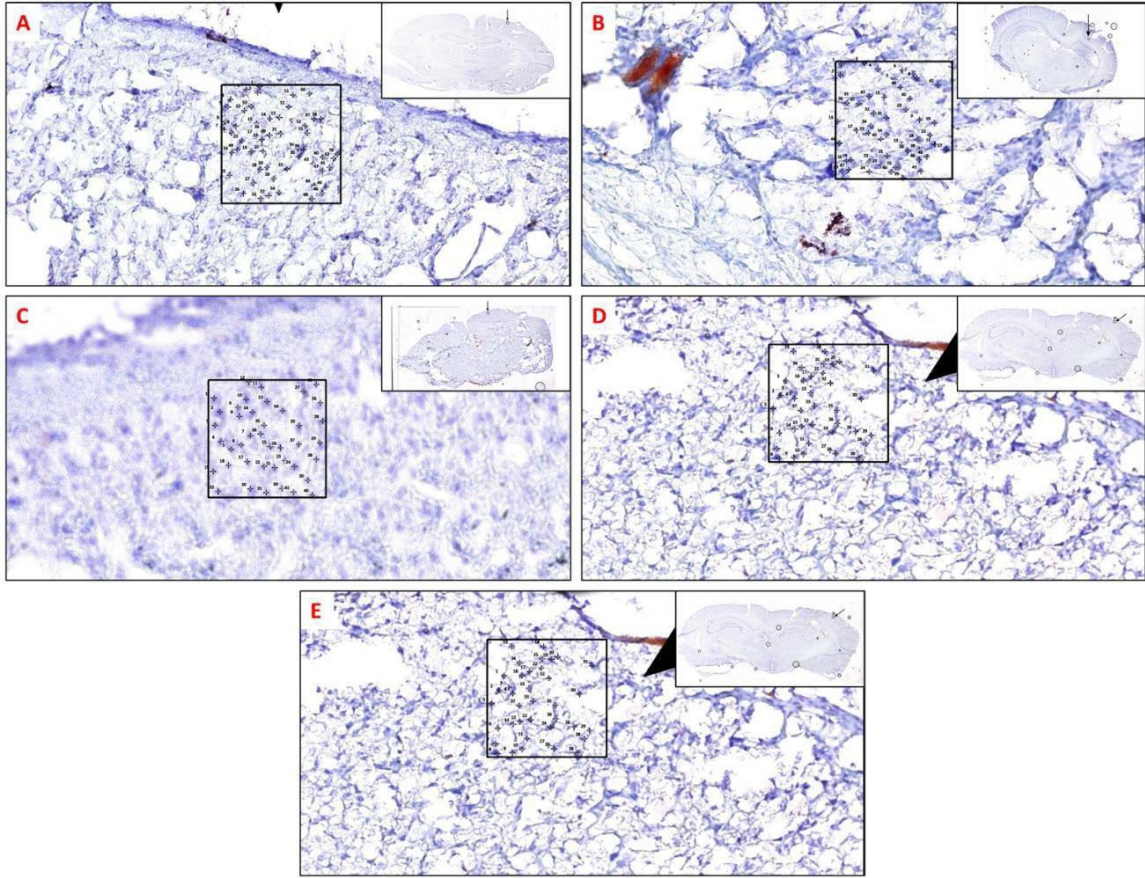




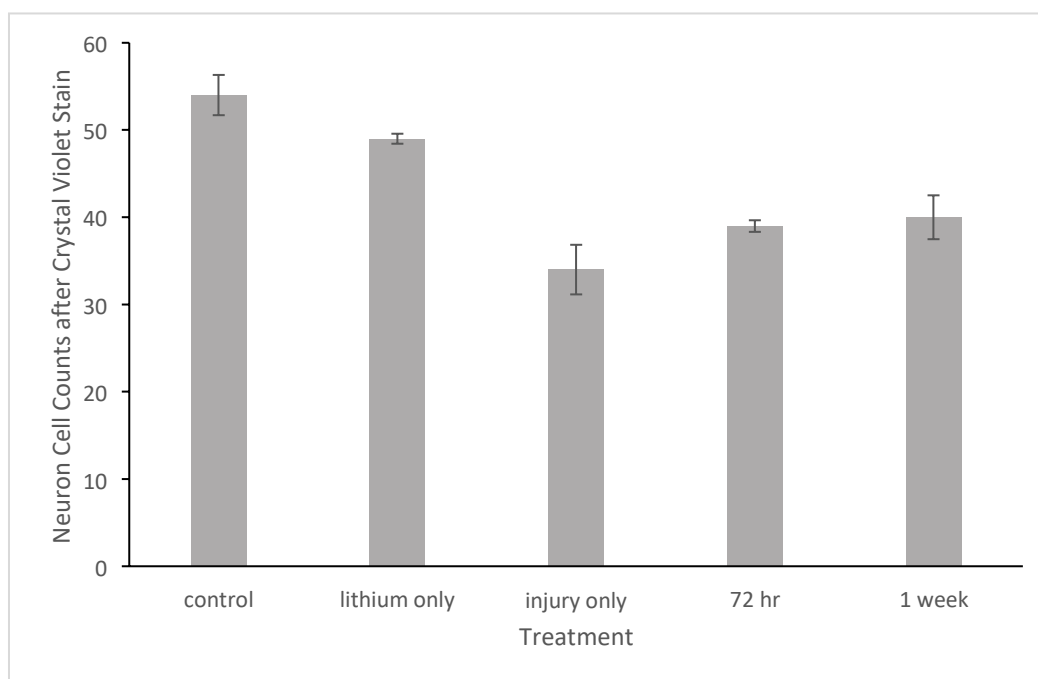
**Figure 3.4** Bar graph of plasma results. The amount of tracer in the blood plasma was not significantly different between the no injury and treatment with lithium for 1-week groups. Top: Percentage of tracer compared to the no injury control. Each treatment was compared to the no injury control. Graph shows significant decreases in tracer levels with subsequent longer treatments of lithium. Bottom: The level of tracer in circulating blood. After designated treatment lengths, rats were sacrificed, and blood was immediately collected from the systemic circulation. Serum was removed and 20 uL was analyzed by a fluorescent plate reader for presence of fluorescently labeled, high molecular weight tracer.



**Figure 3.5** Scanned images of a brain section showing the Cresyl violet stained cells Top : 3 regions in the cortex area of a whole brain section were selected for analysis of this study Bottom : Three region at 50x magnification, showing the individual neuronal cells Each box represents an area of 200X200 um.



**Figure 3.6:** Representatives figures showing the cell count in a region in a whole brain section for each condition at 100x magnification A) Control, B) Lithium only, C) Injury only, D) 72 hours treatment, E) 1 week treatment



**Fig 3.7** Bar graph of cell count. There is a distinct difference between the number of cells in the brain tissue sections (coronal plane) of control animal and injured animal. With LiCl treatment post injury, an increase in number of cells.

Count of crystal violet labeled cells differed significantly among length of lithium treatment after injury (one-way ANOVA,  $F(4,10) = 15.45$ ,  $N = 3$ ,  $p < 0.001$ ). Post-hoc independent samples t-tests, with Bonferroni correction ( $\alpha$  adjusted to 0.005), revealed significant differences between the control and 72 hours treatment groups ( $t(4) = -6.10$ ,  $p < 0.004$ ), and lithium and 72 hours treatment groups ( $t(4) = -10.96$ ,  $p < 0.001$ ) but not between control and lithium groups ( $t(4) = 2.10$ ,  $p = 0.104$ ), control and injury only groups ( $t(4) = 5.36$ ,  $p > 0.005$ ), control and 1 week treatment groups ( $t(4) = -4.1$ ,  $p = 0.015$ ), lithium and injury only groups ( $t(4) = -5.05$ ,  $p > 0.007$ ), lithium and 1 week treatment groups ( $t(4) = -3.49$ ,  $p = 0.025$ ), injury only and 72 hours treatment groups ( $t(4) = 1.71$ ,  $p = 0.163$ ), injury only and 1 week treatment groups ( $t(4) = 1.49$ ,  $p = 0.21$ ), or 72 hours treatment and 1 week treatment groups ( $t(4) = 0.256$ ,  $p = 0.811$ ).

### 3.5 DISCUSSION

Due to rupture of BBB resulting from FPI, a high level of FITC tracer accumulation was expected which is observed by injecting large molecular weight tracer like FITC into the CSF [31]. As expected, the results show a significant difference between tracer level in injured and control animal which can be decreases by the LiCl treatment (Fig. 3.1). In the above graph (Fig 3.2), indicating very less or almost no significant difference between the tracer level between control and treatment with LiCl for a week group, even though after 24 hours and 72 hours an increase of tracer level was seen. Small level of tracer signifies less leakage of tracer into the circulation because the blood-brain barrier and in extent, the central nervous system are intact and not damaged. Due to natural healing nature of BBB, this study alone cannot conclude the neuroprotectivity of neurons after TBI.

To support the observation of the tracer level, a quantitative study was performed. An examination of Cresyl Violet stained sections produces a clear demonstration of neuronal loss post FPI. As shown in Fig 3.3, LiCl treatment resulted in a time dependent cell number increase post FPI injury. The difference in the number of cells in the FPI injured animal (Fig 3.3 C) as compared to the control animal or the animal treated with LiCl without FPI (Fig 3.3 A & B) reversed with treatment of LiCl post FPI for 72 hours and 1 week (Fig D & E). This result demonstrated the neuroprotectivity of lithium brain post injury. These findings may shed some light on possible treatment and alleviate some of the effects of TBI.



## **CHAPTER 4**

### **CONCLUSION**

Considering the clinical application of lithium for several neurodegenerative and central nervous system diseases, this literature has investigated the effects of lithium as a protective agent against various insults resulting in serious brain injury.

Recent studies by [24] have shown neural survival in rat cerebral cortical cultures treated with 1 mM LiCl for 5-6 days against excitotoxicity of 8-10  $\mu$ M glutamate. The study had marked significant protection at 0.2 mM and virtually complete protection at 1 mM. Cerebral cortex being the primary target in the brain involved in the therapeutic actions of lithium. The study also demonstrated less significant neuroprotection at or below concentration 0.6 mM while declined at a dose higher than 1.2 mM which could be related to lithium toxicity. In another similar study [27], primary culture of cerebellar granule cells was exposed to glutamate insult through activation of NMDA receptors. Rat cerebellar cells were treated with glutamate for 24 hours and preincubated for 7 days with 2 mM LiCl. The study showed that the degree of protection depends on the preincubation time and lithium concentration. For this experiment, the significance was detected at 0.5 mM and the maximal effect was observed at 3 mM. From all the experiments and data, it can be concluded that the lithium protection against glutamate toxicity occurs within the therapeutic range i.e., 0.5-1.5 mM.

The blood brain barrier (BBB) is formed by a highly selective semipermeable endothelial cells that prevents circulating toxins or pathogens in the blood to reach central nervous system while at the same time allowing vital nutrients to enter the brain. The breakdown of BBB causes neuroinflammation and neurodegeneration which contributes to neurological disease [32]. Mechanical stress associated with TBI, injure blood vessels in the br

-ain causing cortical, subarachnoid hemorrhage (SAH) contusion, subdural and epidural hematomas. Animal model FPI, produces similar damages to the brain as observed in TBI patients such as focal contusions, petechial intraparenchymal hemorrhages, SAH and axonal injury [33]. Therefore, level of tracer in the circulation signifies disturbance of the blood-brain barrier. Thus, measuring the tracer level in the CSF will give a vague idea about lithium's protection against FPI at its therapeutic level as established by the previous study [34]. According to the experimental data performed for this thesis, the leakage of tracer in the blood diminishes with prolonged treatment with LiCl post injury.

Nissl-stained sections quantified the cell loss and how lithium affects neurons post injury [35]. This data reveals that lithium can be used for clinical treatment of TBI as it shows promising effect on protection of neural cells. Various studies have found lithium to be protective against glutamate excitotoxicity [24], TBI induced neuronal degeneration [18] and this neuroprotection associated with a wide range of factors like GSK-3, PI3K/Akt [36], Bcl-2, downregulation NMDA receptors [25], downregulation of microRNA (miR- 34a) [37] .

## CHAPTER 5

### FUTURE PERSPECTIVE

Along with neuroprotective properties of lithium, several preclinical studies have shown that lithium treatment promotes neurogenesis post injury [38]. Injured nerve cells undergo apoptosis which is caused by several factors. One aspect that highly contributes to cell death is low level of Bcl-2 which has capacity to regenerate cells after injury. Huang et al. [39] studied the regeneration assay model which shows survival of cultured retinal ganglion cells and its neurite number and length of regenerating retinal ganglion cells associated with up-regulation of Bcl-2 upon treating with lithium (0.5-5 mM for 5 days).

In a preclinical study on rodent quinolinic acid induced striatal injury model, Chuang et. al [38, 40] has demonstrated short term lithium exposure promotes proliferation of cells of astroglial and neuronal phenotypes i.e., neural stem cells. In the adult brain, neural stem cells are located in subventricular zone. BrdU labeling in lithium treated injured striatum revealed a large number of proliferating BrdU labeled cells near the quinolic and injection sites following reduction of BrdU cells in the subventricular area.

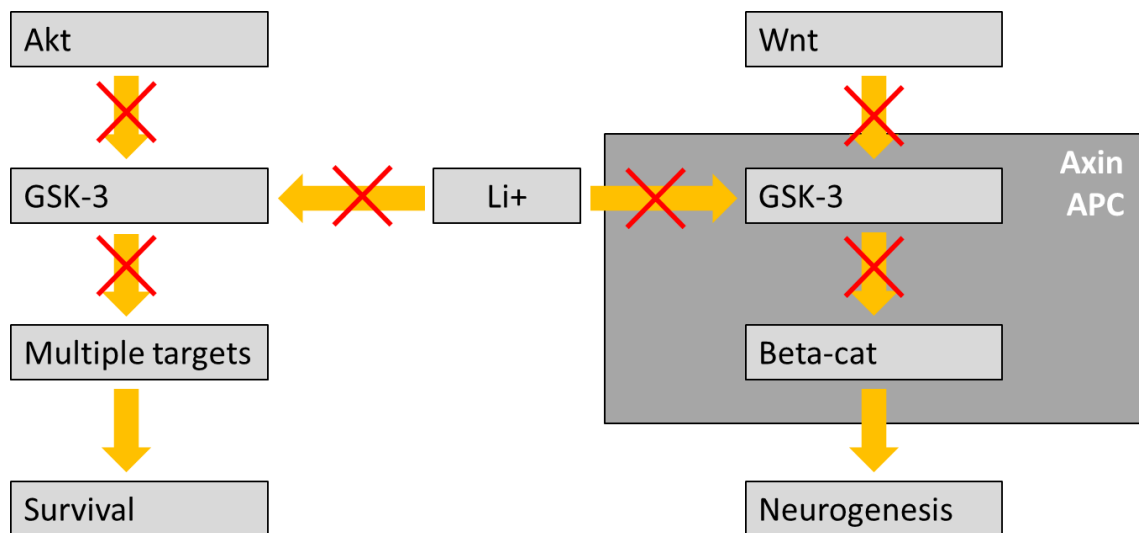
Understanding the mechanism by which lithium can induce neurogenesis, has evolved since the discovery. In 2007, Silva et. al [41] found in lithium treatment reversed the effect of chronic mild stress in rats which led to decreased hippocampal cell proliferation. The stress increased GSK-3B protein expression. Lithium by inhibition of GSK-3B blocked the negative effects of chronic mild stress on behavior and cellular functions.

In vitro rat spinal cord model reported enhancement of cell proliferation and neuronal production of neural progenitor cells after transplantation in presence of lithium [42]. Lithium activates P13K-Akt, which in turn upregulates the signaling of Notch, a stem cell gene that pre



-vents differentiation, through gain control pathway. GSK-3B phosphorylates and inhibits Notch [43]. Lithium by inhibition of GSK-3B, indirectly helps to disinhibit Notch.

More recent studies indicate that the lithium effect on hippocampal neurogenesis requires Wnt/B-catenin activation due to GSK-3B inhibition. In study by Wexler et al. [44] in 2008, it has been reported that the lithium stimulates proliferation of adult hippocampus progenitor cells at therapeutically relevant doses. These effects are independent of IMP but depend on Wnt pathway and inhibition of GSK-3B. For example, RNAi inhibition of B-catenin abolishes the proliferative effects of lithium.



**Figure 5.1** GSK-3 regulates Wnt and Akt-dependent signaling. Akt is activated by growth factors including neurotrophins, which in turn inhibits GSK-3 by phosphorylation allowing activation of factors which promote cell growth. Wnt target genes promote neurogenesis which is activated by inhibition of GSK-3 within the Axin complex stabilizing b-catenin. Lithium activates Wnt/b-catenin which stimulates neurogenesis and cell growth. Source : [45]

In summary, recent studies of lithium at a preliminary level, has demonstrated robust beneficial effects in experimental models of TBI not just by preventing cell loss or neuroprotectivity but also stimulating cell growth, taking part in neurogenesis actively. By controlling several factors which promotes cell growth, lithium enhances the cell growth especially the regeneration of axons in the mammalian Central Nervous System (CNS), neurite outgrowth and increases axonal growth rate. Further research on lithium will raise the possibility of lithium to be used in clinical settings as a treatment for compensation of neural loss resulted by TBI [26, 46].

## REFERENCES

1. Oliveira, J., et al., *Lithium nephrotoxicity*. Revista da Associação Médica Brasileira (1992), 2010. **56**: p. 600-6.
2. Joseph A. Shehadi, M., FRCSC, FACS, *Brain Injurt Awareness Month*. Neurosurgery Associates, LLC, 2020.
3. Saatman, K.E., et al., *Classification of traumatic brain injury for targeted therapies*. J Neurotrauma, 2008. **25**(7): p. 719-38.
4. Veenith, T., S. Goon, and R.M. Burnstein, *Molecular mechanisms of traumatic brain injury: the missing link in management*. World J Emerg Surg, 2009. **4**: p. 7.
5. Rana, A., et al., *Traumatic Brain Injury Altered Normal Brain Signaling Pathways: Implications for Novel Therapeutics Approaches*. Current Neuropharmacology, 2018. **16**.
6. Phillip Thronton, D., *Lithium*. Drugs.com, 2020.
7. Decker, B.S., et al., *Extracorporeal Treatment for Lithium Poisoning: Systematic Review and Recommendations from the EXTRIP Workgroup*. Clin J Am Soc Nephrol, 2015. **10**(5): p. 875-87.
8. Pappas, S., *What is Lithium?* LIVESCIENCE, 2018.
9. Flavio Guzman, M., *Lithium's Mechanism of Action : An Illustrated Review*. Pscopharmacology Institute, 2019.
10. Schloesser, R.J., K. Martinowich, and H.K. Manji, *Mood-stabilizing drugs: mechanisms of action*. Trends Neurosci, 2012. **35**(1): p. 36-46.
11. Ashok, A.H., et al., *The dopamine hypothesis of bipolar affective disorder: the state of the art and implications for treatment*. Mol Psychiatry, 2017. **22**(5): p. 666-679.
12. Berk, M., et al., *Dopamine dysregulation syndrome: implications for a dopamine hypothesis of bipolar disorder*. Acta Psychiatr Scand Suppl, 2007(434): p. 41-9.
13. Cousins, D.A., K. Butts, and A.H. Young, *The role of dopamine in bipolar disorder*. Bipolar Disord, 2009. **11**(8): p. 787-806.
14. Pisano, S., et al., *Putative Mechanisms of Action and Clinical Use of Lithium in Children and Adolescents: A Critical Review*. Curr Neuropharmacol, 2019. **17**(4): p. 318-341.
15. Malhi, G.S., et al., *Potential mechanisms of action of lithium in bipolar disorder. Current understanding*. CNS Drugs, 2013. **27**(2): p. 135-53.
16. Baandrup, U., J.P. Bagger, and S. Christensen, *Myocardial changes in rats with lithium-induced uraemia*. Acta Pathol Microbiol Immunol Scand A, 1985. **93**(6): p. 317-22.
17. Agas, A., *Profiling the neurovascular cell interactions in alcohol exposure and HIV-1 infection*. New Jersey Institute of Technology, Newark, NJ, 2017.
18. Zhu, Z.F., et al., *Neuroprotective effect and cognitive outcome of chronic lithium on traumatic brain injury in mice*. Brain Res Bull, 2010. **83**(5): p. 272-7.
19. Fan, J., et al., *Neural Activities in Multiple Rat Brain Regions in Lithium- Pilocarpine- Induced Status Epilepticus Model*. Front Mol Neurosci, 2019. **12**: p. 323.

20. Wang, N., et al., *Minocycline inhibits brain inflammation and attenuates spontaneous recurrent seizures following pilocarpine-induced status epilepticus*. Neuroscience, 2015. **287**: p. 144-56.
21. Chen, R.W. and D.M. Chuang, *Long term lithium treatment suppresses p53 and Bax expression but increases Bcl-2 expression. A prominent role in neuroprotection against excitotoxicity*. J Biol Chem, 1999. **274**(10): p. 6039-42.
22. Chen, G., et al., *The mood-stabilizing agents lithium and valproate robustly increase the levels of the neuroprotective protein bcl-2 in the CNS*. J Neurochem, 1999. **72**(2): p. 879-82.
23. Forlenza, O.V., V.J. De-Paula, and B.S. Diniz, *Neuroprotective effects of lithium: implications for the treatment of Alzheimer's disease and related neurodegenerative disorders*. ACS Chem Neurosci, 2014. **5**(6): p. 443-50.
24. Hashimoto, R., et al., *Lithium protection against glutamate excitotoxicity in rat cerebral cortical neurons: involvement of NMDA receptor inhibition possibly by decreasing NR2B tyrosine phosphorylation*. J Neurochem, 2002. **80**(4): p. 589-97.
25. Nonaka, S., C.J. Hough, and D.M. Chuang, *Chronic lithium treatment robustly protects neurons in the central nervous system against excitotoxicity by inhibiting N-methyl-D-aspartate receptor-mediated calcium influx*. Proc Natl Acad Sci U S A, 1998. **95**(5): p. 2642-7.
26. Dell'Osso, L., et al., *A new look at an old drug: neuroprotective effects and therapeutic potentials of lithium salts*. Neuropsychiatr Dis Treat, 2016. **12**: p. 1687- 703.
27. Wada, A., et al., *Lithium: potential therapeutics against acute brain injuries and chronic neurodegenerative diseases*. J Pharmacol Sci, 2005. **99**(4): p. 307-21.
28. Alder, J., Fujioka, W., Lifshitz, J., Crockett, D.P., Thakker-Varia, S., *Lateral Fluid Percussion: Model of Traumatic Brain Injury in Mice*. Mice. J. Vis. Exp. (54), e3063, doi:10.3791/3063 (2011). Abstract: Traumatic brain injury (TBI) research has attained renewed momentum due to the increasing awareness of, 2011.
29. Ma, X., et al., *Animal Models of Traumatic Brain Injury and Assessment of Injury Severity*. Mol Neurobiol, 2019. **56**(8): p. 5332-5345.
30. Ma, X., et al., *Hemorrhage Associated Mechanisms of Neuroinflammation in Experimental Traumatic Brain Injury*. J Neuroimmune Pharmacol, 2020. **15**(2): p. 181-195.
31. Cheng, Y., et al., *Alcohol promotes waste clearance in the CNS via brain vascular reactivity*. Free Radic Biol Med, 2019. **143**: p. 115-126.
32. Obermeier, B., R. Daneman, and R.M. Ransohoff, *Development, maintenance, and disruption of the blood-brain barrier*. Nat Med, 2013. **19**(12): p. 1584-96.
33. Chodobski, A., B.J. Zink, and J. Szmydynger-Chodobska, *Blood-brain barrier pathophysiology in traumatic brain injury*. Transl Stroke Res, 2011. **2**(4): p. 492- 516.
34. Senatorov, V.V., et al., *Short-term lithium treatment promotes neuronal survival and proliferation in rat striatum infused with quinolinic acid, an excitotoxic model of Huntington's disease*. Molecular Psychiatry, 2004. **9**(4): p. 371-385.
35. García-Cabezas, M.Á., et al., *Distinction of Neurons, Glia and Endothelial Cells in the Cerebral Cortex: An Algorithm Based on Cytological Features*. Frontiers in Neuroanatomy, 2016. **10**(107).

36. Overall, I.P., et al., *Lithium ameliorates HIV-gp120-mediated neurotoxicity*. Mol Cell Neurosci, 2002. **21**(3): p. 493-501.
37. Hunsberger, J.G., et al., *Mood stabilizer-regulated miRNAs in neuropsychiatric and neurodegenerative diseases: identifying associations and functions*. Am J Transl Res, 2013. **5**(4): p. 450-64.
38. Guang Chen, G.R., Fu Du, Navid Seraji-Bozorgzad, Hussein K. Manji, *Enhancement of Hippocampal Neurogenesis by Lithium*. Journal of Neurochemistry, 2002. **75**(4).
39. Xizhong Huang, D.-Y.W., Guang Chen, Hussein manji, Dong feng Chen, *Support of Retinal Ganglion Cell Survival and Axon Regeneration by Lithium through a Bcl-2-Dependent Mechanism*. investigative ophthalmology & visual science, an ARVO journal, 2003. **44**(1).
40. Senatorov, V.V., et al., *Short-term lithium treatment promotes neuronal survival and proliferation in rat striatum infused with quinolinic acid, an excitotoxic model of Huntington's disease*. Mol Psychiatry, 2004. **9**(4): p. 371-85.
41. Silva, R., et al., *Lithium blocks stress-induced changes in depressive-like behavior and hippocampal cell fate: the role of glycogen-synthase-kinase-3beta*. Neuroscience, 2008. **152**(3): p. 656-69.
42. McKenzie, G., et al., *Cellular Notch responsiveness is defined by phosphoinositide 3-kinase-dependent signals*. BMC Cell Biol, 2006. **7**: p. 10.
43. Espinosa, L., et al., *Phosphorylation by glycogen synthase kinase-3 beta down-regulates Notch activity, a link for Notch and Wnt pathways*. J Biol Chem, 2003. **278**(34): p. 32227-35.
44. Wexler, E.M., D.H. Geschwind, and T.D. Palmer, *Lithium regulates adult hippocampal progenitor development through canonical Wnt pathway activation*. Mol Psychiatry, 2008. **13**(3): p. 285-92.
45. Valvezan, A. and P. Klein, *GSK-3 and Wnt Signaling in Neurogenesis and Bipolar Disorder*. Frontiers in Molecular Neuroscience, 2012. **5**(1).
46. Leeds, P.R., et al., *A new avenue for lithium: intervention in traumatic brain injury*. ACS Chem Neurosci, 2014. **5**(6): p. 422-33.