

## **Copyright Warning & Restrictions**

The copyright law of the United States (Title 17, United States Code) governs the making of photocopies or other reproductions of copyrighted material.

Under certain conditions specified in the law, libraries and archives are authorized to furnish a photocopy or other reproduction. One of these specified conditions is that the photocopy or reproduction is not to be “used for any purpose other than private study, scholarship, or research.” If a user makes a request for, or later uses, a photocopy or reproduction for purposes in excess of “fair use” that user may be liable for copyright infringement,

This institution reserves the right to refuse to accept a copying order if, in its judgment, fulfillment of the order would involve violation of copyright law.

**Please Note: The author retains the copyright while the New Jersey Institute of Technology reserves the right to distribute this thesis or dissertation**

Printing note: If you do not wish to print this page, then select “Pages from: first page # to: last page #” on the print dialog screen

The Van Houten library has removed some of the personal information and all signatures from the approval page and biographical sketches of theses and dissertations in order to protect the identity of NJIT graduates and faculty.

## ABSTRACT

### MECHANICAL DESIGN AUTOMATION: A CASE STUDY ON PLASTIC EXTRUSION DIE TOOLING

by  
**Allen Prasad Varghese**

The **Skills Gap** in Mechanical Engineering (ME) Design has been widening with the increasing number of baby boomers retiring (Silver Tsunami) and the lack of a new generation to acquire, practice and perfect their knowledge base. This growing problem has been addressed with several initiatives focused on attracting and retaining young talent; however, these types of initiatives may not be timely for this new group to be trained by an established Subject Matter Expert (SME) group. Automated Engineering Design provides a potential pathway to address not only the **Skills Gap** but also the transfer of information from SMEs to a new generation of engineers. **Automation** has been at the heart of the Advanced Manufacturing Industry, and has been successful at accomplishing repetitive tasks with processes, software and equipment. The next stage in Advanced Manufacturing is further integrating **Machine Learning** techniques (Artificial Intelligence (AI)) in order to mimic human decision making. These initiatives are clear for the type of mechanized systems and repetitive processes present in the manufacturing world, but the question remains if they can be effectively applied to the decision heavy area of ME Design. A collaboration with an industry partner New Jersey Precision Technologies (NJPT) was established in order to address this question. This thesis presents an ME Design Automation process involving a multi-stage approach: Design Definition, Task Differentiation, Workflow Generation and Expert System Development. This process was executed on plastic extrusion tooling design. A Computer Aided Design (CAD) based

Expert System was developed for the **Automation** of design, and the generation of a database towards future **Machine Learning** work. This system was run on **6** extrusion product examples previously designed by NJPT through traditional methods. The time needed to generate the design was reduced by **95-98%**. This thesis demonstrates the capability of automating ME design, the potential impact in industry and next steps towards the application of AI.

**MECHANICAL DESIGN AUTOMATION: A CASE STUDY  
ON PLASTIC EXTRUSION DIE TOOLING**

**by  
Allen Prasad Varghese**

**A Thesis  
Submitted to the Faculty of  
New Jersey Institute of Technology  
in Partial Fulfillment of the Requirements for the Degree of  
Master of Science in Mechanical Engineering**

**Department of Mechanical and Industrial Engineering**

**August 2019**

Blank Page

**APPROVAL PAGE**

**MECHANICAL DESIGN AUTOMATION: A CASE STUDY  
ON PLASTIC EXTRUSION DIE TOOLING**

**Allen Prasad Varghese**

---

Dr. Samuel C. Lieber, Dissertation Advisor Date  
Assistant Professor of School of Applied Engineering and Technology, NJIT

---

Dr. Zhiming Ji, Committee Member Date  
Professor of Mechanical and Industrial Engineering, NJIT

---

Dr. Lu Lu, Committee Member Date  
Assistant Professor of Mechanical and Industrial Engineering, NJIT

---

Mr. Bob Tarantino, Committee Member Date  
President of New Jersey Precision Technologies, NJ

## **BIOGRAPHICAL SKETCH**

**Author:** Allen Prasad Varghese

**Degree:** Master of Science

**Date:** August 2019

### **Undergraduate and Graduate Education:**

- Master of Science in Mechanical Engineering,  
New Jersey Institute of Technology, Newark, NJ, 2019
- Master of Engineering in Mechanical Engineering,  
Lancaster University, United Kingdom, 2017
- Bachelor of Engineering in Mechanical Engineering,  
Lancaster University, United Kingdom, 2016

**Major:** Mechanical Engineering



This dissertation is dedicated to my family,  
Prasad, Annie and Fantin who have stood by me through this journey

## **ACKNOWLEDGMENT**

I wish to thank the many friends and professors who helped me in this endeavor. My guide, Dr. Samuel C. Lieber for his undying support and guidance during the entire duration of this project. Without his motivation and help I would not have been able to complete this paper. I would like to thank Mr. Bob Tarantino, President of New Jersey Precision Technologies, for funding this project and his dedication by always being there to answer any kind of question that I had during this project. I would like to appreciate the time taken by Dr. Zhiming Ji and Dr. Lu Lu in reviewing this thesis and providing valuable feedback. I also appreciate all the help provided to me by the engineering team especially Michal Obloj, Laurie Bertolotti, Andrew Boho, Andrew Wagner and Jack Pobicki at New Jersey Precision Technologies.

## TABLE OF CONTENTS

<b>Chapter</b>	<b>Page</b>
1 INTRODUCTION .....	1
1.1 Thesis Objective.....	1
1.2 Skills Gap.....	2
1.3 Design Automation Process .....	4
1.4 Automated mechanical engineering design .....	20
1.5 Background on plastic extrusion.....	30
2 DESIGN DEFINITION .....	37
2.1 Design of extrusion tooling.....	37
2.2 Audit of extrusion tooling design process at NJPT.....	48
2.3 Audit of extrusion tooling manufacturing process at NJPT.....	53
2.4 Automation platform.....	58
3 TASK DIFFERENTIATION AND WORKFLOW GENERATION .....	63
3.1 Task differentiation .....	63
3.2 Design protocol for die plate.....	70
3.3 Design protocol for adapter plate .....	101
3.4 Design protocol for transition plate.....	109
4 EXPERT SYSTEM DEVELOPMENT .....	123
4.1 Compilation of design parameters .....	123
4.2 Graphical user interface .....	126
4.3 Routine methods .....	134

**TABLE OF CONTENTS**  
**(Continued)**

<b>Chapter</b>	<b>Page</b>
4.4 Verification and testing .....	177
5 CONCLUSIONS, LIMITATIONS AND FUTURE WORK .....	200
5.1 Conclusion .....	200
REFERENCES .....	202
APPENDIX A PROGRAM VERIFICATION INSTANCES .....	207
APPENDIX B EXPERT SYSTEM SOURCE CODE.....	220
APPENDIX C DRAWING SHEET GENERATED BY EXPERT SYSTEM.....	221
APPENDIX D EXPERT SYSTEM TRAINING DOCUMENT .....	240

## LIST OF TABLES

<b>Table</b>	<b>Page</b>
2.1 Hole Design Routine Where 0 = No Holes and 1 = Holes Are Required.....	46
2.2 List of Hole Sizes Used for Extrusion Tooling.....	47
2.3 Commonly Used Dowel Sizes for Extrusion Tooling Plates.....	48
3.1 Formula-Based Methods Found in Extrusion Tooling Design.....	64
3.2 Experiential Methods Found in Extrusion Tooling Design.....	66
3.3 Drawdown and Wall Thickness Percentage Values for Common Polymers.....	76
3.4 Extension and Offset Values for Leg Modification.....	78
3.5 Nominal Diameters for Ball End Mill Tool.....	88
4.1 Compilation of Design Parameters Required for Automation.....	124
4.2 Compilation of Routines Used in Automated Extrusion Tool Design Program.....	134
4.3 Priority Selection Algorithm for Base Segment of The Profile.....	140
4.4 Test Cases Selected for Verification of Expert System.....	177
4.5 Test Cases Selected From Real Extrusion Designs at NJPT for Verification.....	184
4.6 Results From Running the Test Cases From Table 4.4 in the Expert System.....	187
4.7 Comparison of Manual Design Time with Program Design Time.....	197
4.8 Output from Expert System Printed Into a Preliminary Knowledge Base.....	198

## LIST OF FIGURES

<b>Figure</b>	<b>Page</b>
1.1 Design automation system describing comparison between tasks performed by an automated system and human designer.....	5
1.2 The product making use of a defined set of inputs that were derived based on its function and using them to generate desired set of outputs.....	6
1.3 Dividing the overall problem into individual sub problems which allows creation of easier strategies to get the overall system solution.....	7
1.4 Classification of artificial intelligence software technologies used for design automation.....	12
1.5 The different components of a knowledge-based engineering system and how they interact with each other.....	13
1.6 Representation of design lead time saved by incorporating knowledge-based engineering.....	14
1.7 The different components of a knowledge-based engineering system and how they interact with each other.....	16
1.8 The IICAD system developed to automate design of power transmission.....	21
1.9 Automated design system used for gear generation.....	22
1.10 Collecting the initial design parameters for design of aircraft wings.....	23
1.11 Web-based knowledge-based system for CAD model generation and manufacturing of Industrial Battery Stack.....	24
1.12 The proposed filtering system that analyzes CAD feature inputs for manufacturability and provides Go or No-Go outputs.....	26
1.13 The proposed architecture for an automated manufacturability assessment system.....	27
1.14 The Wire EDM department at New Jersey Precision Technologies.....	29
1.15 Basic flow diagram depicting the plastic extrusion process flow.....	31

**LIST OF FIGURES**  
**(Continued)**

<b>Figure</b>	<b>Page</b>
1.16 Plastic extrusion overall process flow diagram .....	31
1.17 Schematic diagram of a single screw plastic extruder .....	32
2.1 Different types of profile extrusion dies; (a) Plate die, (b) Stepped die, (c) Streamlined die .....	37
2.2 Extrusion die assembly; (a) Exploded view; (b) Assembled view .....	38
2.3 (a) Adapter plate; (b) Transition plate; (c) Spider plate; (d) Die plate .....	39
2.4 Overall work flow for design of extrusion tooling .....	41
2.5 Types of blanks, (a) Rectangular blank, (b) Round blank .....	44
2.6 Extrusion plates held together with socket head screws .....	45
2.7 Types of holes found on a transition plate .....	46
2.8 Overall workflow depicting concept to final product design followed by NJPT ...	50
2.9 Various layers shown with their name and the description of the segments contained within them.....	51
2.10 A small portion of the knowledge base containing experiential data of parameters used to design extrusion tooling .....	52
2.11 Inter-relationship between the engineering and manufacturing team at NJPT .....	53
2.12 Operating work flow of manufacturing extrusion tooling .....	54
2.13 Workflow diagram showing manufacturing processes used for producing extrusion tooling plates .....	55
2.14 Wire electrical discharge machine showing contact between electrode and workpiece .....	56
2.15 Ram EDM used to create cavity on the workpiece.....	57
2.16 Hole Popper used to create small holes on the workpiece.....	57

**LIST OF FIGURES**  
**(Continued)**

<b>Figure</b>	<b>Page</b>
2.17 Front-end user interface of ANVIL two-dimensional CAD software .....	59
2.18 API help page within SolidWorks showing all functions and their parameters .....	61
3.1 Sample U-shaped profile selected as product profile for creating extrusion tooling .....	71
3.2 Die plate is the highlighted plate in the extrusion tooling assembly .....	72
3.3 Overall workflow describing the decisions taken to design extrusion die plates ...	73
3.4 Determining the true center of the product profile .....	74
3.5 Scaling the profile to adjust for drawdown effect.....	75
3.6 Adjusting wall thickness of the profile to account for die swell.....	77
3.7 Profile leg having length L .....	77
3.8 Profile leg extended by $e_1$ inches for leg length greater than 3/8 inches .....	78
3.9 Offset the leg inwards by an inward extension of $e_2$ inches for leg length greater than 3/8 inches .....	79
3.10 Offset the sides of the legs by $e_3$ inches to add flares for leg length greater than 3/8 inches .....	79
3.11 Join the points of intersection between the flares, extension and the inward offset for leg length greater than 3/8 inches.....	80
3.12 Assign the same radii of the initial profile to the leg extension profile for leg length greater than 3/8 inches .....	80
3.13 Profile with its leg extended and flares added for leg length greater than 3/8 inches .....	81
3.14 Extend the tip of the leg by $e_1$ inches for leg length less than 3/8 inches.....	81
3.15 Offset the sides of the legs by $e_3$ inches to add flares for leg length less than 3/8 inches .....	82



**LIST OF FIGURES**  
**(Continued)**

<b>Figure</b>	<b>Page</b>
3.16 Join starting points of the leg with points of intersection between flares and extension for leg length less than 3/8 inches .....	82
3.17 Add the same radius of the initial leg profile onto the leg extension profile for leg length less than 3/8 inches .....	83
3.18 Trim all the construction lines to obtain the leg extension profile for leg length less than 3/8 inches .....	83
3.19 (a) L-Joint with a single flow restrictor, (b) T-Joint with two restrictors, (c) Cross-Joint with four restrictors.....	84
3.20 Dimensions of a flow restrictor found at the joints of an extrusion profile.....	84
3.21 Positioning the flow restrictor along the joint of an extrusion profile.....	85
3.22 Trim lines to obtain the flow restrictor profile.....	85
3.23 Inlet profile of the die plate with flow restrictors .....	86
3.24 Inlet of an extrusion die plate showing the lead-in .....	86
3.25 Lead-in profile represented in dashed lines .....	88
3.26 Tool path for ball-end mill to create lead-in .....	89
3.27 Round blank for the die plate.....	91
3.28 Adding boundary lines at the corners of the die plate .....	91
3.29 Bolt center of the die plate for placing holes .....	92
3.30 Placing the first hole on a round die plate.....	92
3.31 (a) Counterbore and Clearance hole pattern, (b) Drill and Tap hole pattern .....	93
3.32 Identifying the number of holes required in a die plate .....	94
3.33 Positioning the first constraint for dowel holes .....	95

**LIST OF FIGURES**  
**(Continued)**

<b>Figure</b>	<b>Page</b>
3.34 Extruder output and breaker clearance condition for dowel placement .....	96
3.35 Placing dowel holes at the calculated locations .....	96
3.36 Rectangular blank for the die plate .....	97
3.37 Bolt positioning offset for rectangular die plate .....	98
3.38 Counterbore and clearance hole on a rectangular die plate .....	98
3.39 Identifying the number of holes required in a rectangular die .....	99
3.40 Dowel hole placement for rectangular plate .....	100
3.41 Adapter plate is the highlighted plate in the extrusion tooling assembly .....	101
3.42 Overall design workflow involved in designing an adapter plate.....	102
3.43 Inlet profile of an adapter plate .....	103
3.44 Generic rectangular outlet profile and its dimensions .....	104
3.45 Generic hourglass outlet profile and dimensions.....	104
3.46 Generic round outlet profile and dimensions.....	105
3.47 Generic rectangular slot outlet profile and dimensions .....	105
3.48 Custom outlet profile of adapter plate .....	106
3.49 Round blank for the adapter plate .....	106
3.50 Drill and tap holes on a round adapter plate .....	108
3.51 Placing dowel holes at the calculated locations on adapter plate .....	108
3.52 Transition plates are the highlighted plates in the extrusion tooling assembly .....	109
3.53 Design workflow showing the steps involved in designing the transition plate.....	110

**LIST OF FIGURES**  
**(Continued)**

<b>Figure</b>	<b>Page</b>
3.54 Inlet profile of the transition plate with ribs .....	111
3.55 Outlet profile of trans same as inlet of the die plate with lead-in .....	111
3.56 Determining thickness of transition plate .....	112
3.57 Intermediary profile in the case of multiple transition plates .....	113
3.58 Calculating offset for intermediary transition profile .....	114
3.59 Round blank for the transition plate.....	116
3.60 Adding boundary lines at the corners of the transition plate .....	117
3.61 Bolt center of the transition plate for placing holes.....	117
3.62 Drill and tap holes on a round transition plate.....	118
3.63 Counterbore and clearance holes on a round transition plate .....	118
3.64 Placing dowel holes at the calculated locations on transition plate .....	119
3.65 Rectangular blank for the transition plate.....	119
3.66 Bolt positioning offset for rectangular transition plate .....	120
3.67 Drill and tap holes on a rectangular transition plate .....	120
3.68 Counterbore and clearance holes on a rectangular transition plate.....	121
3.69 Placing dowel holes that connect transition and die plate .....	121
3.70 Placing dowel holes that connect trans and the adapter plate .....	122
4.1 Overall workflow of the automated extrusion tooling design program.....	123
4.2 Intro page of the main extrusion tooling design form GUI .....	126
4.3 Design parameters derived from the knowledge base used by NJPT .....	127

**LIST OF FIGURES**  
**(Continued)**

<b>Figure</b>	<b>Page</b>
4.4 Profile page of the main extrusion tooling design form GUI .....	128
4.5 Page of extrusion tooling design form GUI that deals with Die plate .....	130
4.6 Page of extrusion tooling design form GUI that deals with Transition plate .....	130
4.7 Page of extrusion tooling design form GUI that deals with Adapter plate .....	131
4.8 GUI showing the leg modification form for the extrusion profile.....	132
4.9 GUI showing the flow restrictor modification form for the extrusion profile.....	133
4.10 (a) Polygon having segments in random orientations, (b) Polygon whose segments are arranged in a counterclockwise direction connected to each other...	138
4.11 (a) Polygon having 3 possible base segments, (b) Polygon having two possible base segments.....	139
4.12 Inverting a segment to be oriented in a counter-clockwise direction .....	141
4.13 Determining true geometric center of a sketch profile .....	142
4.14 (a) Leg with flat ends, Type 1, (b) Leg with flat end and curved corner radii, Type 2, (c) Leg with curved end or full radii, Type 3 .....	146
4.15 Leg modifications for a Type 1 leg with length greater than 3/8 in and having flares and extensions, (a) The outer edge is extended outwards, (b) Outer edge is offset inwards, (c) Sides of the leg are offset sideways to add flares, (d) Lines are joined at the points of intersections, (e) Unwanted lines are trimmed to get the modified leg .....	147
4.16 Leg modifications for a Type 1 leg with length greater than 3/8 in and having only extensions, (a) The outer edge is extended outwards, (b) Outer edge is offset inwards, (c) Lines are joined at the points of intersections, (d) Unwanted lines are trimmed to get the modified leg .....	147
4.17 Leg modifications for a Type 1 leg with length greater than 3/8 in and having only flares, (a) Outer edge is offset inwards, (b) Sides of the leg are offset sideways to add flares, (c) Lines are joined at the points of intersections, (d) Unwanted lines are trimmed to get the modified leg.....	148

**LIST OF FIGURES  
(Continued)**

<b>Figure</b>	<b>Page</b>
4.18 Leg modifications for a Type 1 leg with length less than 3/8 in and having flares and extensions, (a) The outer edge is extended outwards, (b) Sides of the leg are offset sideways to add flares, (c) Lines are joined at the points of intersections and base points of the leg, (d) Unwanted lines are trimmed to get the modified leg.....	149
4.19 Leg modifications for a Type 1 leg with length less than 3/8 in and having only extensions, (a) The outer edge is extended outwards, (b) Lines are joined at the points of intersections and base points of the leg, (c) Unwanted lines are trimmed to get the modified leg.....	149
4.20 Leg modifications for a Type 1 leg with length less than 3/8 in and having only flares, (a) Sides of the leg are offset sideways to add flares, (b) Lines are joined at the points of intersections and base points of the leg, (c) Unwanted lines are trimmed to get the modified leg.....	150
4.21 Routine steps for creating a flow restrictor at the joints of a profile .....	152
4.22 Locating dowel hole position for round blanks .....	158
4.23 Dowel hole pattern followed by NJPT.....	159
4.24 Locating dowel hole position for rectangular blanks.....	160
4.25 (a)Standard hole pattern found on an adapter plate, (b) Non-standard hole pattern on adapter plate .....	161
4.26 (a) Odd arrangement of holes for rectangular plates, (b) Even arrangement of holes for rectangular plates .....	162
4.27 Hole pattern arrangement for adapter, transition1 and die plates for a single round transition plate and non-standard adapter hole pattern case .....	163
4.28 Hole pattern arrangement for adapter, transition1 and die plates for a single round transition plate and standard adapter hole pattern case .....	164
4.29 Hole pattern arrangement for adapter, transition1, transition2 and die plates for double round transition plates and non-standard adapter hole pattern case.....	165

**LIST OF FIGURES**  
**(Continued)**

<b>Figure</b>	<b>Page</b>
4.30 Hole pattern arrangement for adapter, transition1, transition2 and die plates for a double round transition plates and standard adapter hole pattern case .....	166
4.31 Hole pattern arrangement for adapter, transition1 and die plates for a single rectangular transition plate and non-standard adapter hole pattern case .....	167
4.32 Hole pattern arrangement for adapter, transition1 and die plates for a single rectangular transition plate and standard adapter hole pattern case.....	168
4.33 Hole pattern arrangement for adapter, transition1, transition2 and die plates for double rectangular transition plates and non-standard adapter hole pattern case...	169
4.34 Hole pattern arrangement for adapter, transition1, transition2 and die plates for double rectangular transition plates and standard adapter hole pattern case .....	170
4.35 Custom A size drawing template with proper layers assigned used at NJPT .....	172
4.36 Drawing sheet depicting die plate with proper layers assigned used at NJPT.....	174
4.37 Drawing sheet depicting transition 1 plate with proper layers assigned used at NJPT .....	175
4.38 Drawing sheet depicting adapter plate with proper layers assigned being used at NJPT .....	176

## LIST OF ABBREVIATIONS

DA	Design Automation
CAD	Computer Aided Design
CAM	Computer Aided Manufacturing
CBR	Case Based Reasoning
KBE	Knowledge Based Engineering
AI	Artificial Intelligence
DFM	Design for Manufacturing
EDM	Electric Discharge Machining
CNC	Computer Numeric Control
MAS	Manufacturing Analysis System
SME	Subject Matter Expert
VBA	Visual Basic for Applications

# CHAPTER 1

## INTRODUCTION

### 1.1 Thesis Objective

The objective of this thesis is to test the hypothesis that a decision heavy area such as ME design can be automated. This objective was met by first developing an ME Design Automation process involving a multi-stage approach:

- **Design Definition:** Design criteria and methods are defined through review of established published methods and industry practices.
- **Task Differentiation:** Separate the designer decisions from those that are based in *Formulae* or those that are *Experiential*.
- **Workflow Generation:** Develop a standardized design procedure that outlines designer decisions, and is used to train all designers.
- **Expert System Development:** Design and develop software that mimics the designer's workflow decisions.

This process was executed on an industry relevant case study through a collaboration with New Jersey Precision Technologies (NJPT). The case study selected was Plastic Extrusion Tooling Design for several reasons:

- The design is currently driven by a limited number of Subject Matter Experts (SMEs) that base their decisions on both published methods and industry practices.
- The SMEs are completing their careers without overlap to transfer knowledge to the next generation.
- The demand for plastic extruded products has not decreased. Therefore, the demand for plastic extrusion tooling design has not decreased.
- Plastic extrusion design requires a rapid turn-around time that integrates with an advanced manufacturing process for timely delivery of the eventual tooling.



The objective was tested on real world designs by comparing the design time utilizing a developed expert system to previous traditional methods. The expert system also included output to a database providing a platform for future work in machine learning.

## **1.2 Skills Gap**

Skills Gap is defined as the difference in skills required on the job and the actual skills that are possessed by the employees (Zigu, 2018). According to Adecco (2018), a mechanical design engineer requires certain types of skills to perform their function in an industry.

- Critical thinking: Ability to solve complex problems that can arise during design planning.
- Detail oriented: Has to pay attention to the fine details so as to maintain accuracy of the final product with respect to provided specifications.
- Interpersonal skills: Needs to work closely with other engineers or designers to ensure the final design satisfies all specification requirements and also able to take advice regarding design techniques from experienced designers to solve complex problems.
- Time management: Designers need to be able to work effectively under large amounts of stress and should be capable of delivering results at the specified time.
- Manufacturing process understanding: A designer has to be able to recognize the limits of various manufacturing processes and should be able to incorporate safety zones within the design so that there will not be any hindrance in workflow.
- Math skills: Creation of technical drawings will require the designers to tackle various problems that involve simple and complex mathematical calculations involving vectors, geometric analysis like angles, dimensions etc.
- CAD/CAM/CAE: Designers must have sufficient knowledge in working within a computer aided design software and should be aware of general tools used in creating designs and rendering three-dimensional models. Some designers will also

require computer-aided-engineering skills which are used in the simulation study of a designed product.

According to a survey conducted by Deloitte (2015), over the next decade there will be a need to fill around three and a half million manufacturing jobs and a Skill Gap will cause two million of those jobs to remain unfilled. This skills gap is not something unheard of as many prior studies have been conducted and suggest that the industry executives have to invest resources into attracting, training and retaining new talent however, the results have remained unchanged and points to the widening of the skill gap. Employers who were hiring in 2014 claimed that out of all the open jobs available for engineering, 70% of them experienced major difficulty in finding the required talent (Grasz 2014).

Large scale companies are able to invest money in order to train the new recruits however smaller engineering firms rely on the educational establishments for training their students. As the roles within organizations are becoming more complex and technical, an expert who wishes to retire will cause major loss to the organization in terms of revenue since his/her responsibilities will be very difficult to replace. Williams (2018) hints at the possibility of using automated engineering by the OEMs so that they can make pre-configured modules that will contain automated tasks capable of performing functions that were done by engineers repeatedly.

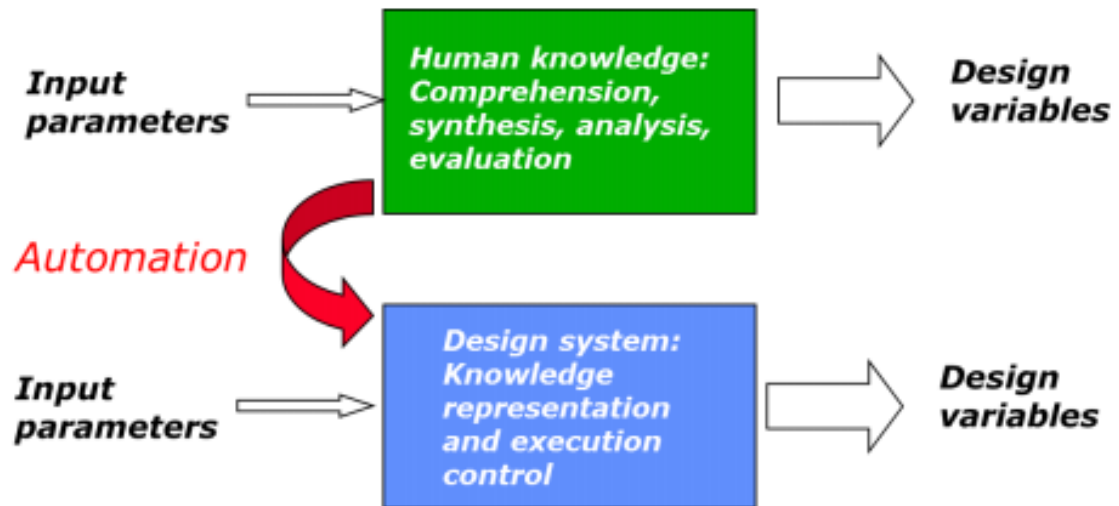
### **1.3 Design Automation Process**

A literature study was done to find the keywords involved in the field of automation in design. The main aim was to create a computer based expert system capable of automating design procedures and methods done by a human designer.

The identified keywords were used to explore the processes followed by other authors and experts to achieve automation in design. Concepts of automation, artificial intelligence and machine learning being used in the field of design have been researched and their respective uses and conditions that warrant their use were identified.

#### **1.3.1 Design Automation**

Design automation can be portrayed as tasks performed by a computer to partly or completely automate sets of functions in mechanical engineering design using advanced software that can mimic the tasks performed by a human designer (Sunnarsjö, 2012). Figure 1.1 describes how a human designer and an automated design system will approach the same problem given the same input parameters. However, the process path taken by both are different, the human designer first comprehends the design problem, synthesizes, analyzes and finally evaluates the approach to solve the problem, whereas the design automated system will use some form of knowledge representation and use the provided information to tackle problems.

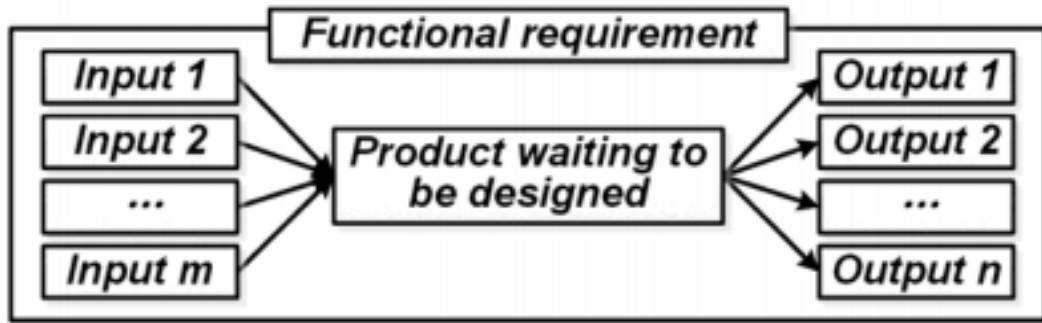


**Figure 1.1** Design automation system describing comparison between tasks performed by an automated system and human designer.

Source: Sunnersjö, S. (2012). Planning design automation systems for product families: A coherent top-down approach.

<http://hj.diva-portal.org/smash/get/diva2:534349/FULLTEXT01.pdf>, accessed July 1, 2019

The fundamental criteria for design automation are to ensure that the computer can handle tasks that are often repeated regularly by human designers and this ensures that the designers will be able to dedicate their time on problems that require creative thinking to solve. The authors Bin and YouBai (2016) states that the key to automating design is to create a functional design scheme that meets the product requirements. This functional design scheme should describe how the input parameters for the design will be used by the automated system to transform them into desired outputs for the design. Figure 1.2 shows an example of what a functional design requirement document can contain. This functional design scheme can be modified based on any engineering design application and possible ways it can be represented are discussed further in this chapter.

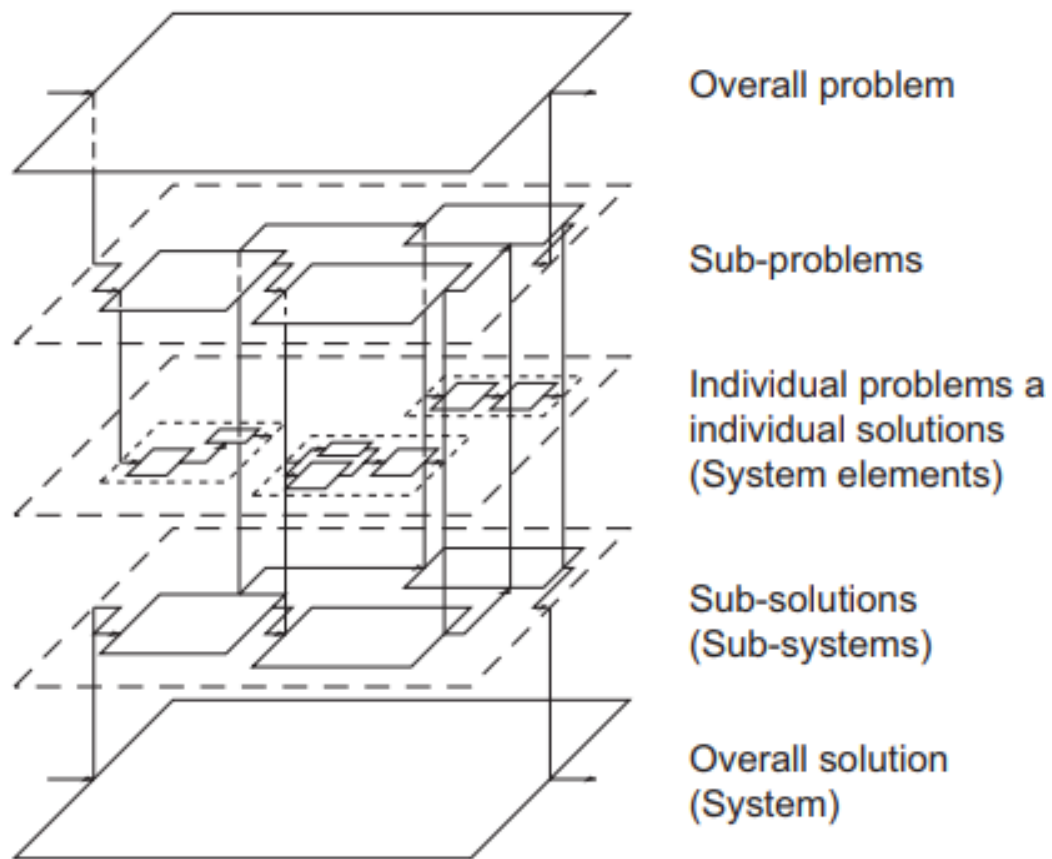


**Figure 1.2** The product making use of a defined set of inputs that were derived based on its function and using them to generate desired set of outputs.

Source: Chen, B. and Y. MXIE (2017). "Functional knowledge integration of the design process." *Science China Technological Sciences* 60(2): 209-218.  
<https://link-springer-com.libdb.njit.edu:8443/content/pdf/10.1007%2Fs11431-016-0236-8.pdf>, accessed July 1, 2019

Once the various functions have been identified, the designers break down the problems to achieve each function through creative strategies and decision making. A study by Cederfeldt (2007) explains that problem solving involves recognizing dependencies, estimating priority of the concerned problem and the amount of flexibility that can be dedicated to it. As seen in Figure 1.3, he further expresses that the overall problem has to be divided into its core sub problems and these individual problems have to be tackled in order to achieve the overall solution for the system.

An automated design system has to have access to these individual problems so that they can be a starting point in attempting to obtain the final solution. Since there is no single design process or design strategy, most solutions are derived from a well analyzed study of the overall problem and is broken down into the fundamental building blocks of the problem.



**Figure 1.3** Dividing the overall problem into individual sub problems which allows creation of easier strategies which can be combined to get the overall system solution.

Source: Cederfeldt, M. (2007). Planning Design Automation: A Structured Method and Supporting Tools. <http://hj.diva-portal.org/smash/get/diva2:33321/FULLTEXT01.pdf>, accessed July 1, 2019

According to Pahl and Beitz (2007), engineering design process can be defined by four main phases that a human designer has to go through, clarification of the task, where all the information regarding the design are collected from the customer and a design specification is laid out. Next, conceptual design, where the design problems are identified and are broken down into fundamental blocks and using combined working principles solutions are derived. Embodiment design where abstract concepts are generated to tackle

the design concepts and make them into a little more concrete proposals and finally detailed designs specifying the characteristics of the concept are generated.

An article written by Trehan et al. (2015) helps to understand how to plan the design process so that it is more suitable for automation. The first step is to determine all the major functions or tasks in the design and organize them sequentially based on their priority based on cost, time or quality trade off. Next the inter-dependencies between tasks have to be determined followed by decomposition of the design process flow into its fundamental building blocks. Finally, all the decomposed objects of the design process flow are mapped into a software system so that it can be controlled with software functions to achieve the desired results.

We can summarize by stating that to prepare the design for automation, the design has to be conceptualized by a human and tasks have to be generated in order to lay out a design process flow. Next, the various design problems have to be understood for each task and they have to be subdivided into its fundamental blocks so that easier strategies can be derived to solve them as a whole to derive the parameters necessary for each function. Once the parameters have been established, the relationship between each parameter and the design flow must be established and quantified in a way that it can be mapped on a computer software. Finally, a set of instructions or a knowledge base has to be provided so that it can be used by the parameters to transform into desired output solutions to finally develop the design. Finally, the developed designs have to be compared with ones created by human designers and the results will be used to further refine the automation process so as to achieve the specified goals.

### **1.3.2 Design Ontology**

An ontology is a method of representing knowledge in a form where it expresses the set of concepts and its relationships within a domain. An ontology has the capability to interact with the entities in the domain and can be thus used to describe the overall domain. The main purpose of ontology generation is to aid in data collection, organization and classification (Henriques, 2014)

The design process can be considered as mostly a mental process since the final drawing sheet do not impart any underlying information regarding how or why the entities were created the way they were. Hence, it is paramount to identify the protocol or the process in which the designer thinks while performing designs in order to make use of in an automated design environment (Finger et al., 1989). Since there is no single pathway or strategy to solve a design problem, it can lead to the use of variable approaches by designers which could in turn increase the possibility of incorrect or inconsistent design information in complex designs. Another major concern is that a lack of protocol can lead to difficulty in imparting consistent design procedure information to new designers who join the team and delivering critical information about why certain design decisions were taken the way it was done.

According to Rocca (2012), the knowledge technologies used in the design are often fuzzy and subjective and to overcome these problems, strategies like data mining and ontology engineering were performed within the organization Airbus to help with identification, acquisition and finally codification of the relevant knowledge that will be used for the overall design process.



### 1.3.3 Intelligent Systems

Intelligence refers to “the capacity to acquire and apply knowledge” (Awad 2003). Knowledge represents how understanding and awareness are achieved which are generally activities that can be identified as human abilities. The intelligence of a machine will always be restricted and defined by the amount of resources it has been programmed with and it can never learn outside its defined boundaries or constraints. Hopgood (2012) explains that the main objective of research in AI (artificial intelligence) is to create and develop a machine that is capable of thinking, mimicking or even exceeding a human’s mental capabilities and one of the variables used to quantify this difference in capability is the time it takes for a machine to achieve the same tasks, its human counterpart would presumably take. Even if the machine is only performing the same tasks that a human would do, it still can be perceived as intelligent when performing tasks that are typically associated with intelligent abilities (Cederfeldt 2007).

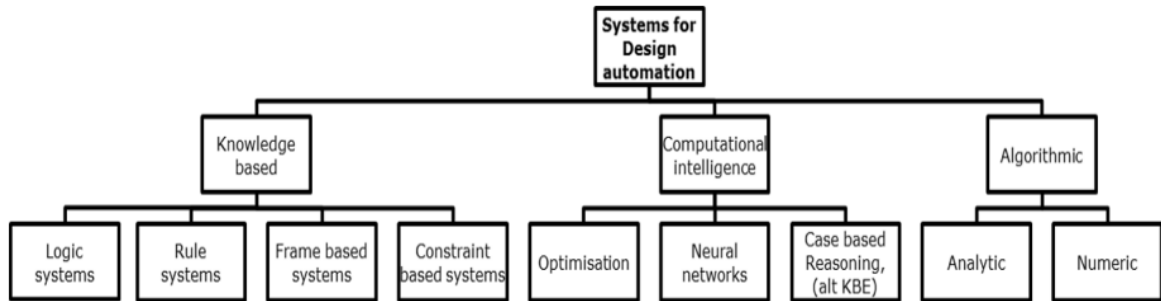
According to Sunnersjö (2012), knowledge can be classified into six classes that represent the major knowledge representation methods,

1. Tacit knowledge: Information that has to definite source and has been embedded in the human mind through common sense, these include intuition, convictions, skills and craftsmanship.
2. Knowledge based on comparison: Here the previously learned lessons were stored and understood to derive new ideas but in some cases, they cannot be applicable since they could have been misunderstood which will lead to failure.
3. Experimental knowledge: This is the knowledge that has come from facts and results obtained through experiments.
4. Geometrically related knowledge: This form of knowledge is very common in mechanical engineering as it has many principles that rely on spatial relationships and geometric reasoning.

5. Knowledge represented in mathematical form: The governing variables of any physical situation can be derived into its mathematical form. This form of knowledge is very useful as it is used for any kind of computational purposes.
6. Heuristic knowledge: Useful guidelines that are often achieved from experience, reasoning and fragments of theory. This kind of knowledge is often developed by designers who have been repeatedly working on projects and have developed a his or her own unique sets of rules to adhere, so as to achieve the final result.

The author Hopgood (2012), divides the different types of intelligent systems or artificial intelligence tools into three main categories: knowledge-based systems, computational intelligence and hybrid systems. Hybrid systems are those that combine knowledge-based systems and computational intelligence and use probabilistic methods and fuzzy logic to handle uncertainty. Sunnersjö (2012), introduces an alternate third category called Algorithmic which is not directly an AI technology however it links to traditional programming and a lot of design problems are still solved using traditional method. Figure 1.4 depicts the classification of knowledge-based systems, computational system and algorithmic systems.

One of these systems or a combination (Hybrid) will be responsible for imparting knowledge or intelligence to a design automation system. Knowledge based systems will include logic systems, rule systems and a constraint system. Computational systems revolve around optimization, neural networks and CBR (case-based reasoning). Case based reasoning refers to analogical reasoning and is used to find common ground among previously stored design cases and these cases are used to understood to create new solutions (Sriram 1997).



**Figure 1.4** Classification of artificial intelligence software technologies used for design automation.

Source: Sunnersjö, S. (2012). Planning design automation systems for product families: A coherent top-down approach.

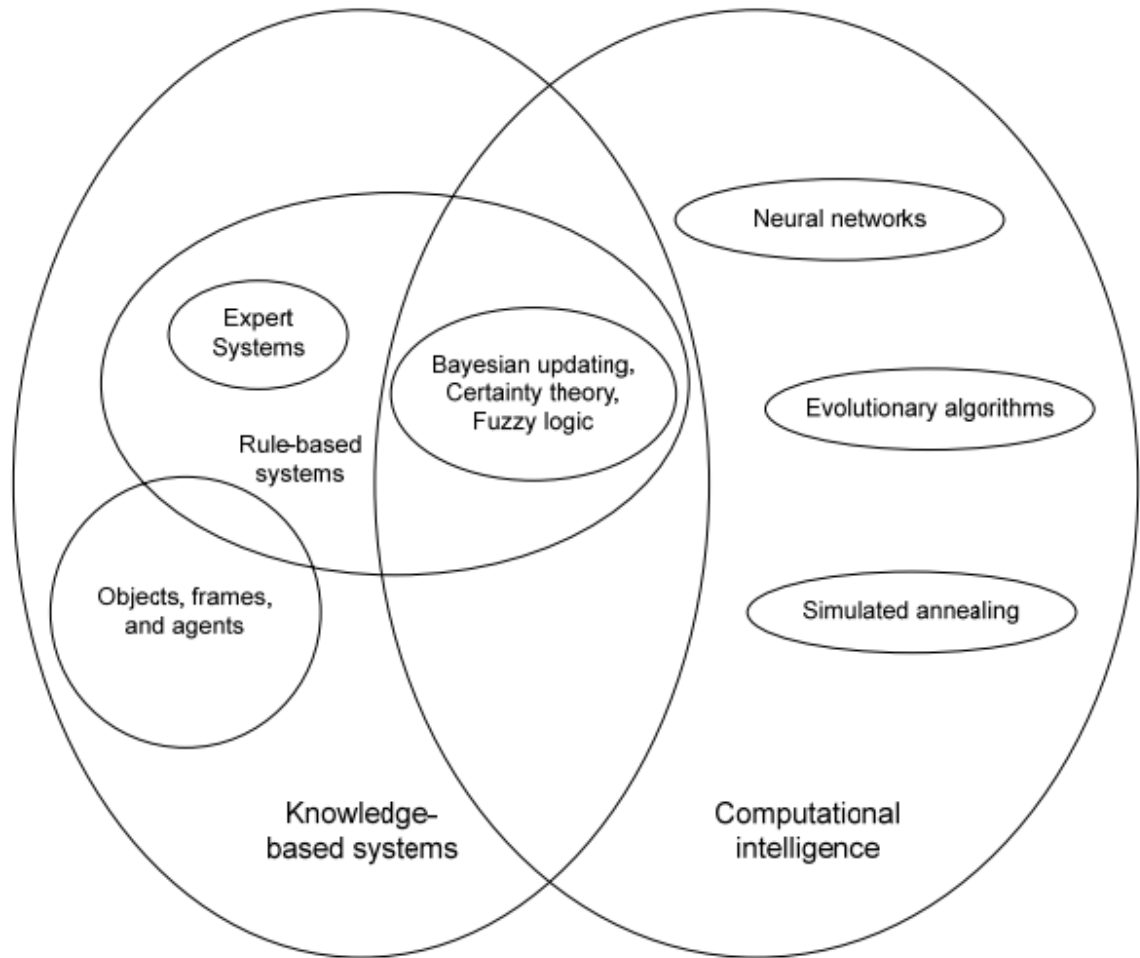
<http://hj.diva-portal.org/smash/get/diva2:534349/FULLTEXT01.pdf>, accessed July 1, 2019

### 1.3.4 Artificial Intelligence and Knowledge Based Engineering

Artificial intelligence can be defined as the branch of computer science that is concerned with the automation of intelligent behavior (Johansson 2008). He further explains that creative thinking is not the main aim of design automation however, it involves automation of routine work in order to allow human designers to perform creative thinking. The knowledge-based system is a sub-category of a broader category called intelligent systems and can be further subdivided into agent-based systems, expert systems and fuzzy logic systems as shown in Figure 1.5.

The authors Nan and Li (2012), defines knowledge-based engineering as a research field that studies and captures engineering knowledge and uses the information to reduce time and cost of product development, primarily obtained from automating repetitive design tasks while capturing, retaining and reusing design knowledge. Knowledge based engineering was introduced in 1980s, when the principles of artificial intelligence were applied on computer aided design. Figure 1.6 describes how knowledge-based engineering

applications automated repetitive design process which results in reduction of lead time, allowing designers to concentrate on more creative work.

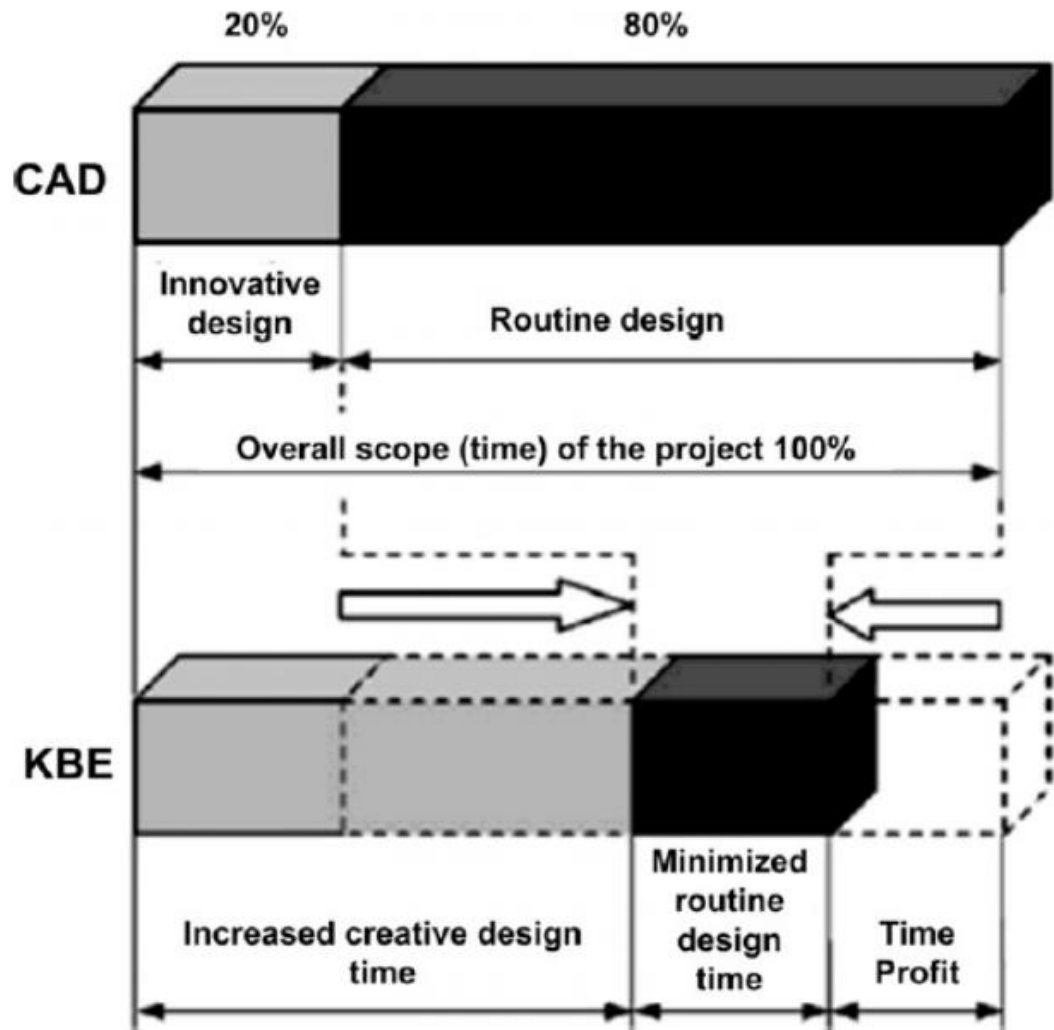


**Figure 1.5** The different components of a knowledge-based engineering system and how they interact with each other.

Source: Hopgood, Adrian A. "Intelligent Systems for Engineers and Scientists", CRC Press, 2012.  
[https://primo.njit.edu/discovery/fulldisplay?docid=alma99149626605781&context=L&vid=01NJIT\\_INST:NJIT&search\\_scope=MyInst\\_and\\_CI&isFrbr=true&tab=Everything&lang=en](https://primo.njit.edu/discovery/fulldisplay?docid=alma99149626605781&context=L&vid=01NJIT_INST:NJIT&search_scope=MyInst_and_CI&isFrbr=true&tab=Everything&lang=en) accessed July 1, 2019

The fundamental aim behind KBE (knowledge-based engineering) is a method that is able to effectively manage complexity of a product through reuse and automation (Amadori et al., 2012). Knowledge based engineering, also sometimes referred to as KBS (knowledge-based system), allows quick and modular designs which can be applied for

mass customization of the product (Verhagen et al., 2012). Its primary benefit is a huge reduction of time to design which directly improves the amount of cost savings for a manufacturing company, especially when their designers deal with a lot of repetitive design tasks being done manually.



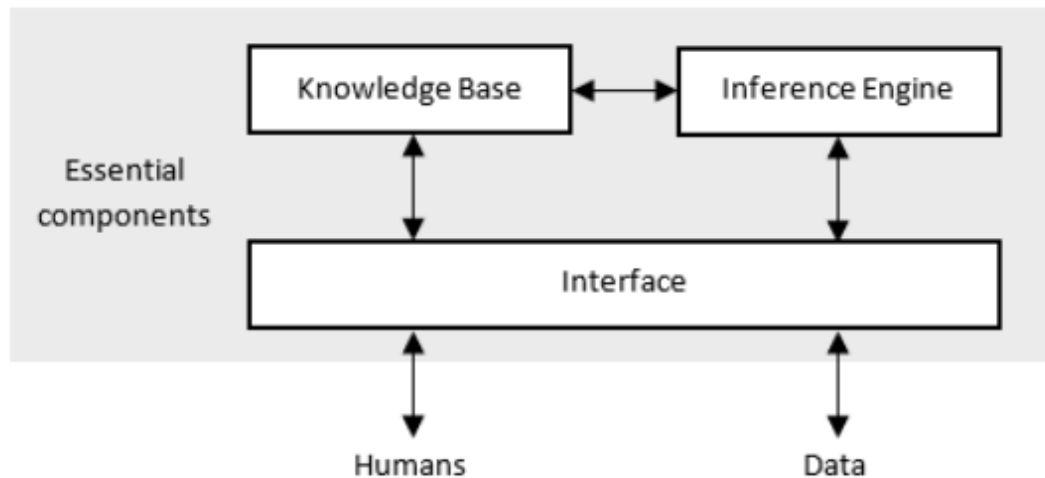
**Figure 1.6** Representation of design lead time saved by incorporating knowledge-based engineering.

Source: Nan, J., & Li, Q. (2012). Design Automation System-Supporting Documentation and Management. <http://hj.diva-portal.org/smash/get/diva2:559193/FULLTEXT01.pdf>, accessed July 1, 2019

It is a rule-based system and it consists of information and rules regarding the product or system to be designed. The information contained within could be and is not limited to CAD (computer aided design) templates, design constraints, geometric dimensions and relations amongst others. Knowledge based systems have three main components as seen in Figure 1.7,

1. Interface: This is the component that interacts between the human designer and the stored data. In the interface the humans will supply the given specifications and the desired data will be returned as output.
2. Knowledge base: This is the database of information that uses the accepts the inputs from the human through the interface and uses its rule bases systems to set constraints and provide a direction for the next component.
3. Inference engine: This is the main driver behind the whole system as it is the component that transforms the information obtained from the knowledge base into geometric data that can be fed into a CAD software to create the required models such that it satisfies all the rules and constraints that were defined in the knowledge base.

The knowledge base, even though contains a large amount of variable design information, it must be stored in format that is machine readable. In this thesis a knowledge base was created through Microsoft Excel and was used to store all the necessary design parameters and variables required for the design. Once the design was completed, fresh data from the latest design was added on to the database to create a self-updating database that improves more with reuse.



**Figure 1.7** The different components of a knowledge-based engineering system and how they interact with each other.

Source: Eklund, A., & Karner, J. (2017). Development of a Framework for Concept Selection and Design Automation: Utilizing hybrid modeling for indirect parametric control of subdivision surfaces. <http://liu.diva-portal.org/smash/get/diva2:1231551/FULLTEXT01.pdf>, accessed July 1, 2019

### 1.3.5 Case Based Reasoning

Case based Reasoning (CBR) is a branch topic of Artificial Intelligence (AI), and it uses old experiences to solve new problems and make new decisions. Understanding and solving new questions in terms of old experiences has two parts: recalling old experience and interpreting the new situation in terms of the recalled experiences. Old solutions can provide almost right solutions to the new problems, and are also able to provide warnings to potential mistakes and failures. According to Kolodner (1992), The quality of a case-based reasoner's solutions depends on four things:

1. The accumulated experiences are not accurate or have always failed.
2. Ability to comprehend new situations from data of old experiences.
3. How quick can the system adapt
4. Adeptness at evaluation of design information.

CBR systems heavily rely on the using of useful previous cases at appropriate times, and CBR systems have the capability of storing new solutions of new cases into the database of solutions for future reference and system growing. Successfully solved problems can be saved for solving similar problems in the future, and even a failure of solving problems can also be reused for preventing this failure happening again. As we can imagine, with the accumulation of existing solutions and variety of different cases, the ability of solving problems and making decisions with better accuracy and wider range is realizable.

The CBR systems can be applied for a wide range of problem-solving tasks, including planning, medical diagnosis, and engineering design. During engineering design process, hundreds and thousands of decisions and problems need to be solved to make a robust product, thus design field is a significant beneficiary of CBR system. The problems in engineering design are usually defined as constraints to the design process. Although the CBR system can also be considered as guidelines to design, one problem can be too huge to solve in one chunk, and each piece of this problem can be interactive to another one or more pieces in this problem. In this case, instead of solving each of the smaller pieces of the problem and compose them back together after finish, one can apply an old solution to the new problem as an entire solution, and adjust those pieces which are not compatible to the new situation. Even though considerable adaptations might be necessary to make the old solution works for the new problem, this methodology is still more preferable and efficient than conventional method of solving one by one. In fact, most of the engineering design works during normal working procedure adapt one solution or merge several solutions together to solve a new issue.



Kong (2003), developed a system for automating 3D plastic injection mold design with the commercial 3D modeling software Solidworks, and associated API functions. This system has speeded up the mold design process and facilitated standardization. Reddy et al. (2016), took advantages of Solidworks API and Microsoft Access as Database software created a system for assisting engineers with the design process of bearings. Users only need to input some critical parameters, such as maximum speed, dynamic load, basic static load, bearing size etc.

Lee (2002), built up a system, which is able to perform self-learning from the accumulated working experience based on case-based reasoning (CBR) with design knowledge and experience as cases for designing die-casting die.

### **1.3.6 Automation Versus Machine Learning**

Automation is the term applied to technology that is used to perform a repetitive task without any external involvement of humans after the initial set up (Girardin, 2018). The author continues by saying that the main practice of automation in manufacturing industries is used to perform tasks that were designed by humans in order to achieve desired characteristics like repeatability, scalability and high quality. The introduction of automation in any industry can lead to a very high boost in efficiency and reduction of time in manufacturing the product. Most commonly, automation is used within industries in the form of mechanical robots that are capable of automatically performing manufacturing tasks.

Machine learning on the other hand is considered as a subset of artificial intelligence. All machine learning counts as Artificial intelligence by not all AI is

considered as machine learning (Artificial Intelligence vs ML, 2018). AI can be if statements that are used to map a complex model into simple categories which are also known as expert systems or knowledge graphs to achieve the desired result. Machine learning on the other hand makes use of the rules engine and expert system to modify itself when exposed to continuous data. In other words, machine learning is dynamic and can change its own program without intervention of humans.

According to Fuge et al. (2014), designers continue to develop new techniques for achieving more and more complex design problems and this collection of methods used can be assigned to a problem-solving toolbox. However, for a human designer to iterate through this toolbox and select the perfect design method can be very overwhelming. The authors introduce the concept of machine learning which is capable of automatically learning patterns in various design methods used in supplied test cases and the program will mine the relevant data on its own, analyzes the data and provides recommendations of design methods to the designer. However, the authors do not apply this concept to any practical expert system that can make use of this recommendation to model and design a product rather it uses these recommendations as a training manual for new designers.

A program that is capable of learning and identifying patterns when provided with a large amount of test cases and able to modify its own program when it achieves desirable results or fails, will be capable of mimicking a human designer in terms of decision making especially when the program is backed by a knowledge base containing rules derived from successful experiential data. Thus, the first step is to create an expert system that is capable of automating all the repetitive tasks performed by the designer before introducing the main machine learning component to it.

#### **1.4 . Automated Mechanical Engineering Design**

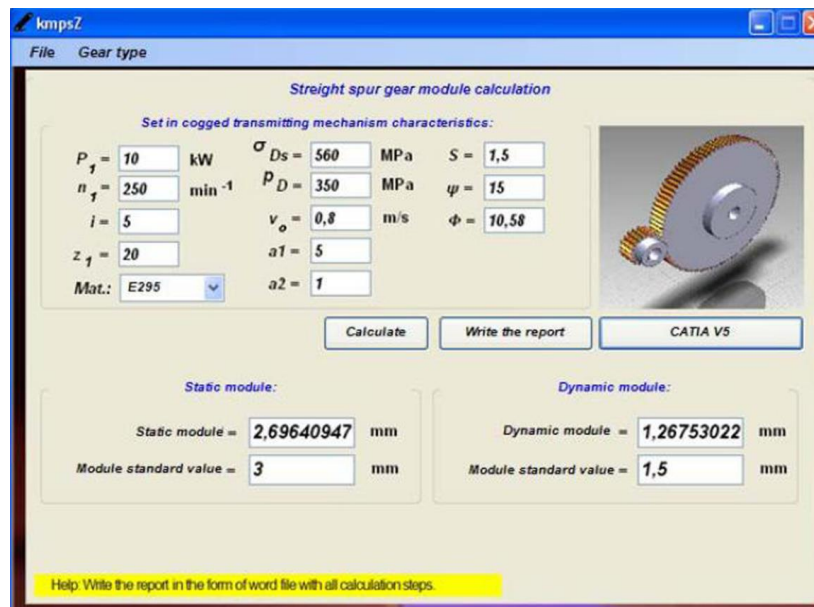
Engineering design is vital for expressing the physical form of any mechanical product such that it meets the specifications set forward by the customer as it usually involves a wide range of creative approaches to solve complex problems at different technical levels that may require variant solution strategies approaches to solve complex problems at different technical levels that may require variant solution strategies (Poorkiany, 2017).

Manufacturers need designers who can step into the manufacturing facility and add value from day one (Lynch, 2016). A designer usually begins a project by understanding the requirements or specifications set forward by the customer and is responsible for laying out an efficient pathway to successfully create a working design of the product while taking into consideration factors like structural properties of materials and identification of feasibility in manufacturing implemented design features.

According to Mechanical Designer: Roles (2016), the minimum educational requirement is an Associate's degree or certificate and these programs include at least one CAD course to get the students to become familiar with the CAD interface however, manufacturing work has become increasingly more technical to the point where very highly skilled designers are required (Lynch 2016). In an industry setting every new employee goes through a training period where they are taught the basic workflow of the industry and how to perform their regular roles and responsibilities but in the case of designers, certain problem-solving skills and techniques of designs can only be attained from another experienced SME.

### 1.4.1 Automated Design in Literature

The authors Saric et al. (2017), developed a system for automating the design process of mechanical power transmitting mechanisms by making use of an integrated intelligent computer-aided design system (IICAD) using the C# programming language in CATIA v5. The system had a graphical user interface (GUI) as seen in Figure 1.8, where the designer could enter parameters values for the design and the system would use these values to create the model using the API methods available through CATIA v5 using C# modules.

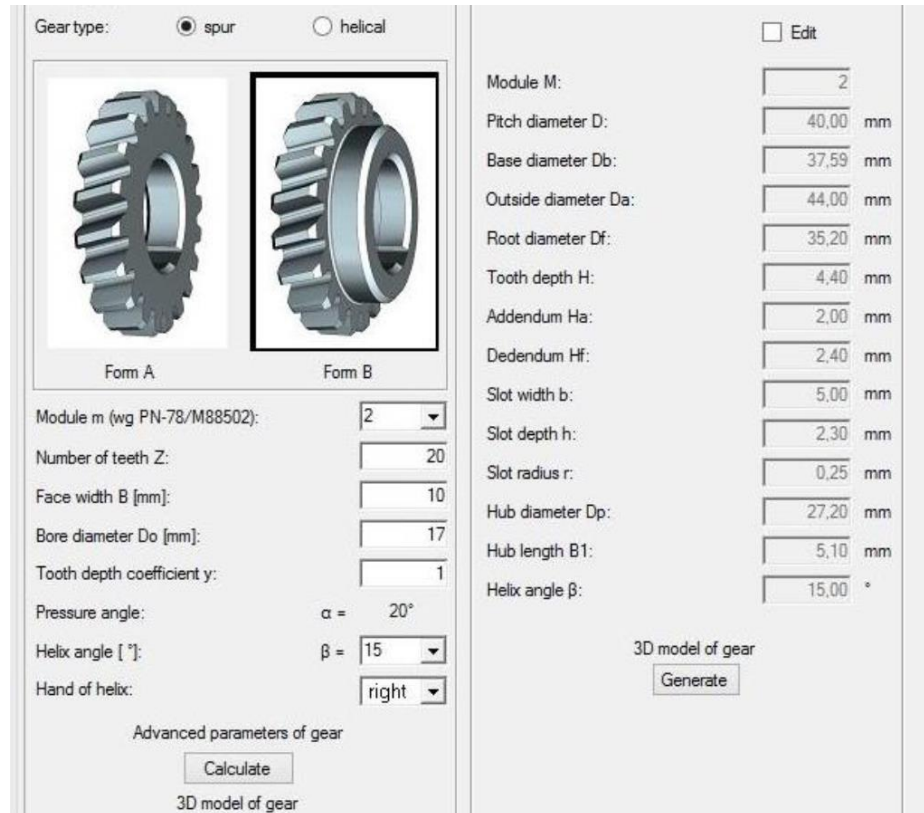


**Figure 1.8** The IICAD system developed to automate design of power transmission.

Source: Saric, I., Muminovic, A., Colic, M., & Rahimic, S. (2017). Development of integrated intelligent computer-aided design system for mechanical power-transmitting mechanism design. *Advances in Mechanical Engineering*, 9(7). <https://doi.org/10.1177/1687814017710389>

Zbiciak et al. (2015), created an automated system for designing gears using API offered by the NX Siemens CAD package with the help of Microsoft Visual Studio and .NET languages. The system had a GUI as seen in Figure 1.9 and would collect the required

design parametric values from the designer and would perform automated design routines to create a gear model.

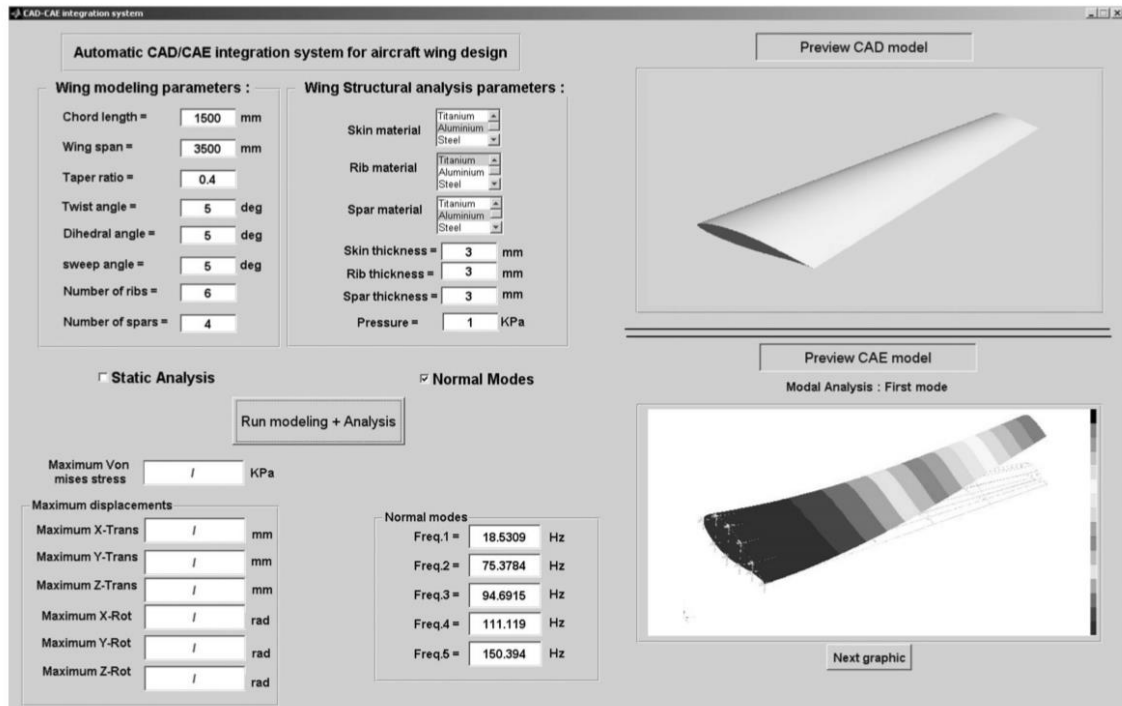


**Figure 1.9** Automated design system used for gear generation.

Source: Zbiciak, M., et al. (2015). "An automation of design and modelling tasks in NX Siemens environment with original software - generator module." IOP Conference Series: Materials Science and Engineering 95: 012117.

Benaouali et al. (2017), merged the concepts of CAD and CAE and created an integrated system to design aircraft wings. This system was capable of obtaining optimized design parameters through CAE analysis of the model. The system usually collected design parametric information from the designers using a GUI as seen in Figure 1.10 and these values were used to build an initial model. This model was then exported automatically

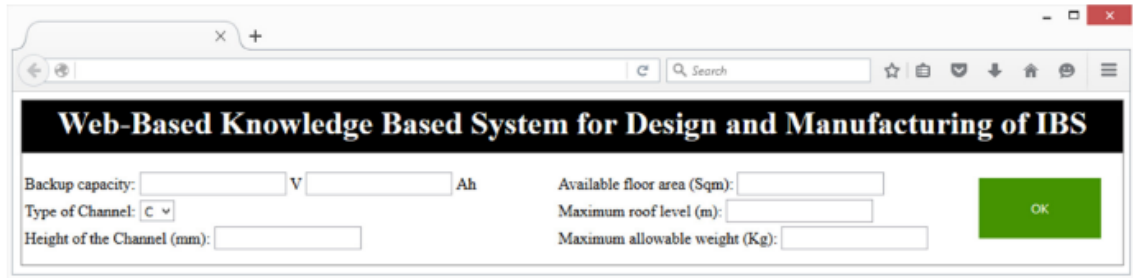
into a CAE package called ANSYS and Von Mises stress optimization was performed to finally obtain the desired model.



**Figure 1.10** Collecting the initial design parameters for design of aircraft wings.

Source: Benaouali, A. and S. Kachel (2017). An automated CAD/CAE integration system for the parametric design of aircraft wing structures.

Reddy et al. (2018), created a web-based knowledge-based CAD modelling and manufacturing system that relied on a GUI as seen in Figure 1.11, that was accessed by the designer through a web interface which allowed a designer to create automated designs from anywhere in the world. The study was done on the automated design of a battery stack and the design approach taken was the design parameters were identified and a knowledge base was created using them which was further utilized to create the overall system.



**Figure 1.11** Web-based knowledge-based system for CAD model generation and manufacturing of Industrial Battery Stack.

Source: Benaouali, A. and S. Kachel (2017). An automated CAD/CAE integration system for the parametric design of aircraft wing structures.

## 1.4.2 Automated Design for Manufacturing

A common problem that can occur in engineering industries is when the overall process is set up in an unintentional sequential order which creates a wall between the key functions and departments in the development process. The lack of inter departmental input during the overall process of the product manufacturing cycle can lead to the product failing to meet certain requests by the customer or it could end up getting more expensive than it needs to be. The philosophy is that the overall manufacturing process should be created simultaneously along with the product development process and should make use of inter-departmental cross-functional teams throughout the process (Cederfeldt, 2007).

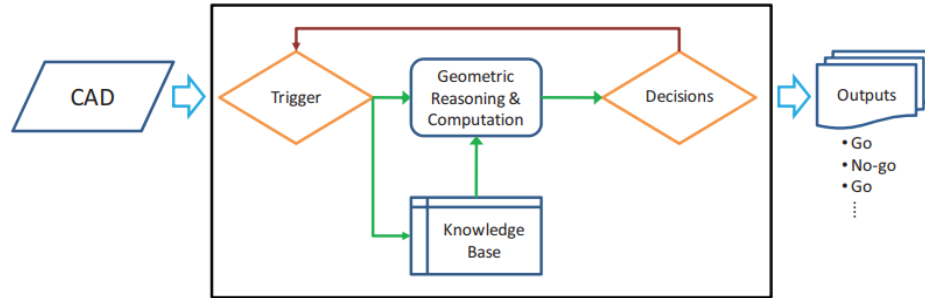
DFM (Design for Manufacturing) is a philosophy that conveys that strategies for manufacturing have to be included during the early stages of design analysis for a product, which in turn will allow the production to become much easier and more economical (Hague et al., 2004). DFM is usually performed by analyzing the various issues that can crop up during the manufacturing process, with respect to the machines used for manufacturing, and taking the defined issues into consideration so that the design can be

influenced by it. Some common methods by which design for manufacturing can be achieved is by creating a modular design, sticking to standard tools and designing for easy fabrication and by following the ideology of concurrent engineering throughout the product development cycle.

The process of design is complex and it has to perform tasks and activities taking into consideration the functional requirements of the product through the all the stages of product development especially with the constraints offered by the machines used to manufacture them. Manufacturing of plastic extrusion die tooling at New Jersey Precision Technologies is done with the help of Wire EDM (Electric Discharge Machining), Sinker EDM, Hole Pop EDM, CNC milling and CNC turning machines. Therefore, designs made must incorporate certain strategies so as to allow seamless production and thus faster results. In this paper, various design for manufacturing fundamental concepts have been incorporated to determine optimized design parameters to create the design.

In the paper authored by Kim (2017), a fast heuristics approach is used to assess the manufacturability without cost estimation analysis. The author states that even though estimating cost for manufacturing is the most complete measure of manufacturability, obtaining that information during the early stages of design is not an easy task since it requires at least 15 factors to be considered. Figure 1.12 represents how the author made use of design for manufacturing criteria to filter certain processes that occurring during the design by analyzing parameters used for creating the model. These parameters serve as the input for the filtering system and outputs are generated only for those processes that satisfy certain requirements that fall under the constraints set by the manufacturing domain.





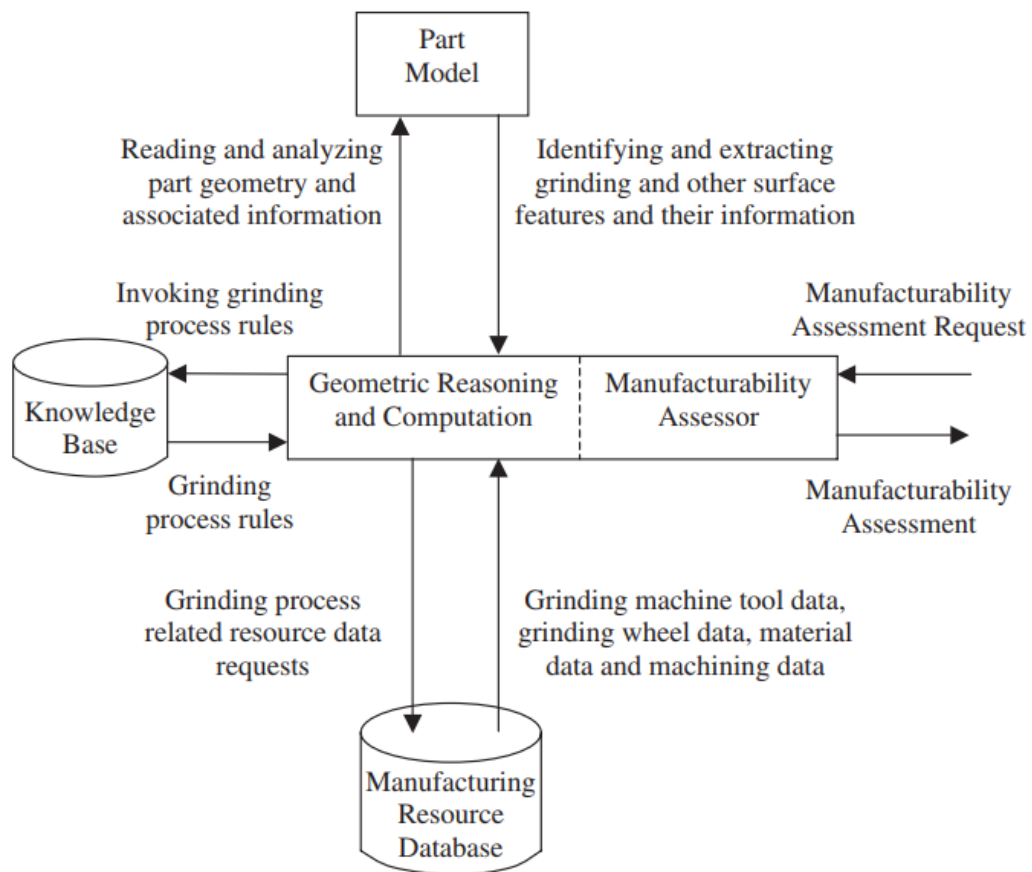
**Figure 1.12** The proposed filtering system that analyzes CAD feature inputs for manufacturability and provides Go or No-Go outputs.

Source: Kim, W., & Simpson, T. (2013). Toward Automated Design for Manufacturing Feedback. Vol. AICT-414, pp. 40–47). Springer. [https://doi.org/10.1007/978-3-642-41266-0\\_5](https://doi.org/10.1007/978-3-642-41266-0_5). <https://hal.inria.fr/hal-01452151/document>, accessed July 1, 2019

In a study performed by Shukor (2009), the authors develop a MAS (Manufacturing Analysis System) which makes use of a number of different approaches, technologies and tools. The author has concluded that most manufacturing analysis systems were construction based on a three step uni-directional flow chart which are data input mechanism where information is extracted from the CAD model or the manufacturing information for the part is obtained from the user, next is analyzing the manufacturability aspects of the collected information using artificial intelligence by comparing input data with a defined knowledge-base containing manufacturing rules and finally the output is generated which includes model redesign suggestions, a direction for proper sequence for design or a list of alteration and suitable materials or processes for manufacturing.

Jacob et al., (2004) developed an automated manufacturability assessment system by checking the given design of a component for manufacturability considerations for grinding operation. These considerations have been programmed as rules which when executed would drive the system by generating advice in terms of possible change in design to allow easier manufacturing. The system deployed by the author can be seen in Figure

1.13 which represents how the design of a product not only contain geometric information but rather also manufacturing information like tolerances, material, roughness etc. The geometric reasoning and computation system modifies the part model based on rules obtained from the knowledge base, along with assessing the feasibility of manufacturing it through the manufacturability assessor and also uses the manufacturing resource database to confirm that the features to be designed on the part model is feasible to be manufactured by the system or not.



**Figure 1.13** The proposed architecture for an automated manufacturability assessment system.

Source: Jacob, D., Ramana, K., & Rao, P. (2004). Automated manufacturability assessment of rotational parts by grinding. *International Journal of Production Research*, 42(3), 505–519. <https://doi.org/10.1080/00207540310001613674>.

### **1.4.3 Design for Manufacturing at NJPT**

New Jersey Precision Technologies, founded in 1989, is the leading and largest all-Mitsubishi Wire EDM and CNC machining service shop in the northeast of United States. Their experienced EDM and CNC machining technicians are factory-trained and their dedicated engineering team is always ready to target the next project. NJPT has over 40 wire EDM, conventional sinker EDM and small hole (hole popper) EDM machines and have accumulated years of experience under their belt by offering comprehensive precision machining services with dozens of CNC milling and CNC turning centers along with grinding, and finishing processes. The main areas of manufacturing applications done by NJPT are in the fields of medical (orthopedics, cardiovascular, endoscopy, pharmaceutical, drug deliver and general medical), plastic extrusion tooling, tool and die, mold making components, semiconductor, aerospace, defense and more. In the field of plastic extrusion tooling, NJPT has accommodated superior tooling design and manufacturing techniques to improve extrusion feed rates by up to 25 percent or more for a variety of extrudates like rigid PVC, flexible PVC, ABS, acrylic and more. Each extrusion tool is optimized to streamline the extrusion pathway and maintain a balanced flow by utilizing designs created by experienced designers to manufacture them. A list of all the machines that are found in NJPT are listed in Appendix D.

A third angle projection of the design is created by the engineering team in a two-dimensional CAD package known as ANVIL. If the tool being designed requires Wire EDM manufacturing, the design is exported into a CAM software known as ESPRIT as a DXF file, where a toolpath will be generated for the electrode in Wire EDM. The designs are created with rules in place so that there won't be any sharp changes to profile thereby

not causing the electrode in the Wire EDM machine to fail. The die plate or the first plate of the extrusion tooling assembly through which the extrudate will come out, is always designed with a feature called lead-in which requires the tool to undergo CNC milling. To generate a toolpath for this process, the design from ANVIL is exported as an IGES file into a CNC specialized CAM package called BOBCAD/CAM. NJPT also uses proprietary software that can read a design sheet in DXF format and identify the locations of all the holes and their information like depth, diameter and type of operation. Along with identifying these holes, the software will also generate G-code and M-code files for the hole popper machine.



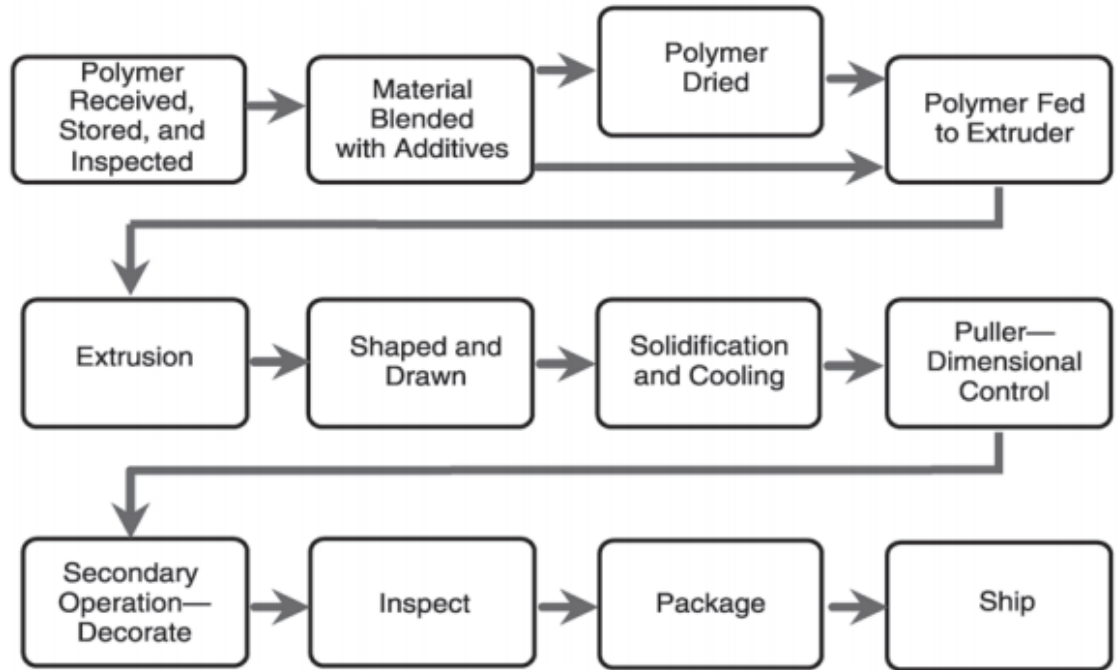
**Figure 1.14** The Wire EDM department at New Jersey Precision Technologies.

Source: New Jersey Precision Technologies, <http://njpt.com>, accessed July 1, 2019

## 1.5 Background on Plastic Extrusion

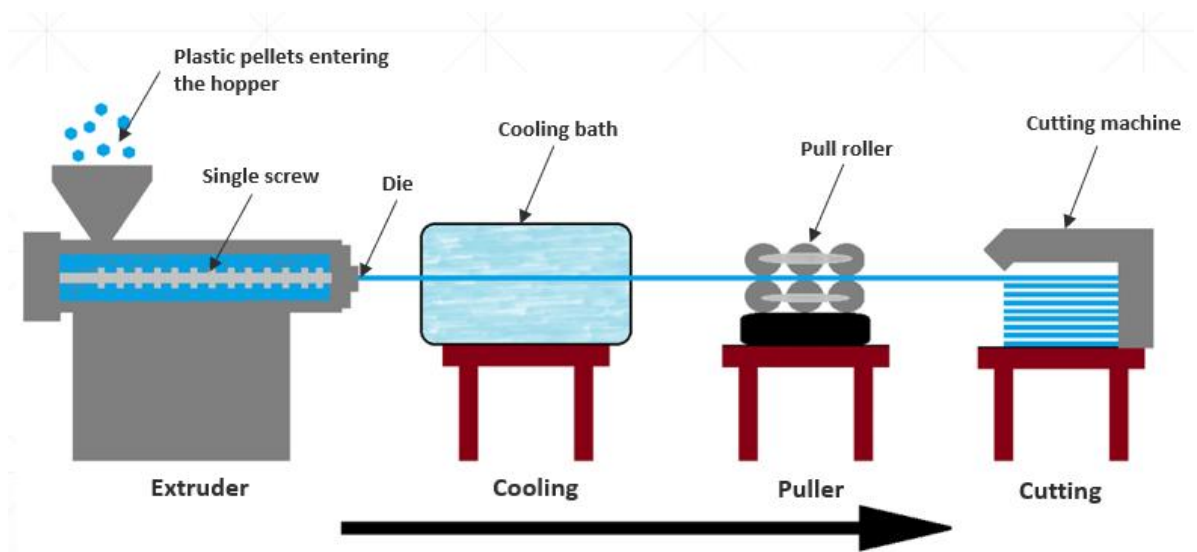
Extrusion is the method used to manufacture a product, also called an extrudate, by forcing it to pass through a die thereby undergoing deformation and reshaping it to the profile of the die the material was forced through. Even though the process may seem very simple, there are many factors that are involved in successfully manufacturing an extruded product. In case the temperature of the extruder is not maintained correctly, or the extrudate is blended improperly, if the cooling after the extrusion is not working, the melt temperature was not defined properly, if the product is being pulled at a greater speed, these are just some of the conditions that could deliver a faulty manufactured product and thus unable to meet the customer's desired specifications (Wagner 2014).

Plastic extrusion as a technology has a very long history dating nearly two centuries (Tadmor, 2013). The author Auvinen (2013), talks about the overall extrusion process and we can see in Figure 1.15 and Figure 1.16, an overview of the plastic extrusion process from the material procurement step. We introduce plastic in the form of pellets, that have been inspected and blended with the necessary additives, into the hopper. The plastic enters the barrel where the plastic melts due to viscous heat generation and friction. This melt is given a positive motion due to the flights of the screw and is forced through the die opening, where the plastic melt is formed into the profile shape of the die. The newly shaped plastic extrudate is then passed through a cooling bath, where it gets cooled uniformly which helps it solidify to its new shape. The extrudate now passes through a pull roller which provides a uniform pulling pressure on the extrudate as well as smoothens the plastic. The final step is where the plastic extrudate is cut into its desired dimensions and stored for inspection, testing and final delivery.



**Figure 1.15** Basic flow diagram depicting the plastic extrusion process flow.

Source: Auvinen, K. (2013). Entrepreneurial guide to starting up a plastics extrusion business. [https://www.theseus.fi/bitstream/handle/10024/56171/kanya\\_auvinen\\_degree\\_thesis.pdf?sequence=1&isAllowed=y](https://www.theseus.fi/bitstream/handle/10024/56171/kanya_auvinen_degree_thesis.pdf?sequence=1&isAllowed=y), accessed July 1, 2019

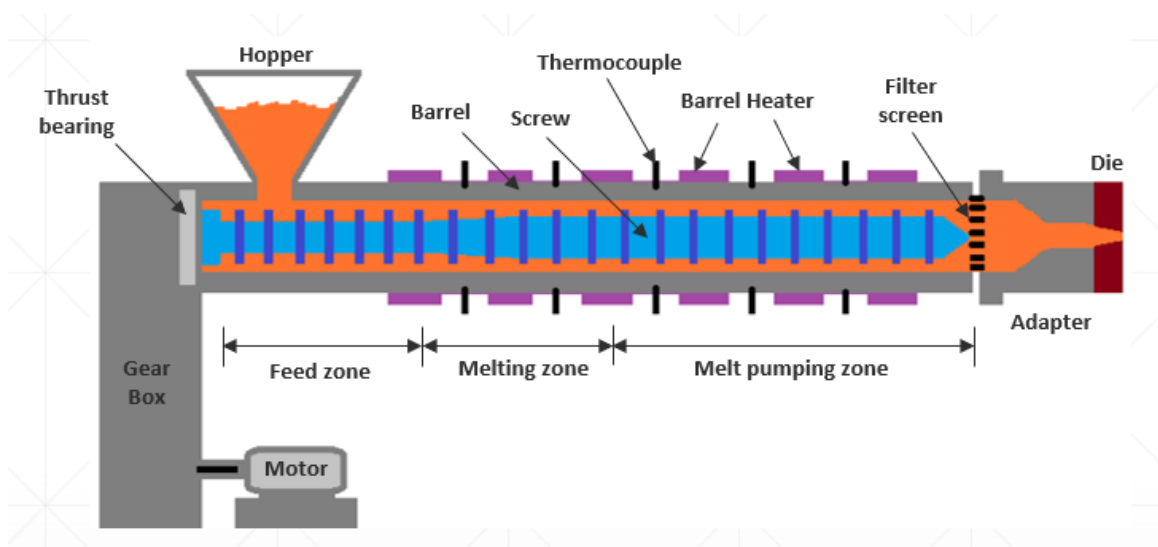


**Figure 1.16** Plastic extrusion overall process flow diagram.

Source: New Jersey Precision Technologies, <http://njpt.com>, accessed July 1, 2019

### 1.5.1 Plastic Extruder

Extruder is identified as the core piece of machinery in the polymer processing industry as it employs the mechanism in which it is used to thrust a polymer in any kind of form with a desired cross section through a die. The geometry of the material coming out will depend on the geometry of the die attached to the end of the extruder and is commonly referred to as the extrudate (Rauwendaal, 2014). In this paper we will be dealing with a single screw plastic extruder as seen in Figure 1.17.



**Figure 1.17** Schematic diagram of a single screw plastic extruder.

Source: New Jersey Precision Technologies, <http://njpt.com>, accessed July 1, 2019

Plastic extruders have three main zones where the polymer undergoes different processes, they are:

1. Feed zone: Here the polymer resin gets fed through the hopper into the barrel. The channel depth in the feed zone remains the same. The input feed rate depends on gravity, polymer weight and density.
2. Melting zone: The polymer melts due to the high pressure and temperature. The rotating screw causes shearing between the polymer wall and also between the layers of polymer which generates heat.

3. Melt pumping zone: The polymer melt is given a positive forced motion towards the die exit using the flights of the screw. The rotation of the screw creates a drag flow and the velocity profile of the polymer near the barrel wall is high and zero at the screw.

### 1.5.2 Plastic Flow in Extruder

There are three main kinds of flow that take place in an extruder (Wagner 2014),

1. Drag flow: It is generated by the rotating screw in the barrel. The velocity profile near the barrel wall is high and zero near the root of the screw. Volumetric drag flow can be calculated with the following equation,

$$Q_D = \frac{\pi^2 \cdot D^2 \cdot N \cdot H \cdot \sin\phi \cos\phi}{2} \quad (1.1)$$

Where,

- D = Diameter of the extruder screw (inches)  
 N = Speed of the extruder (rpm)  
 H = Melt conveying zone channel depth of the extruder (inches)  
 $\Phi$  = Helix angle of the extruder screw

2. Pressure flow: This is a flow that happens in a direction opposite to the drag flow due to the pressure that exists before the die opening. The volumetric pressure flow can be calculated using the following equation,

$$Q_P = \frac{\pi \cdot D \cdot H^3 \cdot \sin^2\phi \cdot dP}{12 \cdot \eta \cdot dL} \quad (1.2)$$



Where,

$P$  = Back pressure inside the extruder (Pa)

$\eta$  = Viscosity of the polymer (Pa s)

3. Leakage flow: This is the possible flow of polymer over the screw flight due to clearance that has appeared over a large period of time resulting from wear and tear. This clearance leads to leakage and is usually negligible in most cases.

According to Wagner (2014), the overall throughput of a polymer at the end of an extruder can be determined by,

$$\text{Output}(Q) = \text{Drag Flow}(Q_D) - \text{Pressure Flow}(Q_P) - \text{Leakage Flow} \quad (1.3)$$

We can neglect leakage flow and substituting equations 1.1 and 1.2 in equation 1.3 we can determine the overall throughput of a polymer at the end of an extruder,

$$Q = \frac{\pi^2 \cdot D^2 \cdot N \cdot H \cdot \sin\phi \cos\phi}{2} - \frac{\pi \cdot D \cdot H^3 \cdot \sin^2\phi \cdot P}{12 \cdot \eta \cdot L} \quad (1.4)$$

### 1.5.3 Plastic Extrusion Analysis Towards Design

Although plastic profile extrusion has been developed for about two centuries of history (Tadmor, 2013), the extrusion tooling design process is still predominantly experienced-based due to multiple variables the resulting unpredictability of polymer melt in the flow channel, and post-effect after the extrudate leaves the die. The large number of variables involved during the plastic extrusion production and the complicated geometry of extrusion

dies presents a challenge for their design to meet not only functional requirements but also lends itself towards initial manufacturing and potential modification in the field. This trial-and-error process is due to many interrelated factors (Beck, 1970), namely:

1. Each thermoplastic material has its own unique extrusion flow characteristics.
2. Each combination of extrusion machine and screw has certain flow generation characteristics.
3. Each extrusion die usually requires testing and modification to perfect the profile being extruded.
4. Each operation environment may vary the extrusion process from case to case.
5. Different operators can also prevent effective production repeatability.

In recent years, the commercial Computer Aided Engineering (CAE) software also offers the possibility of doing the trial of production in the software (Gonçalves et al., 2013; Ulysse, 2002; Rezaei, 2010; Pauli, 2013; Elgeti, 2012), which could lead the designers to the most optimal geometry of extrusion dies. However, because of the number of variables associated with the process and the idealization of some calculation conditions, the numerical analysis cannot perfectly predict the flow. So even with the help of numerical analysis and an experienced designer, this task still has to take 3-5 iterations on redesigning which cost too much time and money. Therefore, it will be very meaningful to predict die shape more precisely (with minimum number of trials).

The possibility and approaches of automating the optimizing process of profile extrusion die have been considered and researched on by many researchers, and there is some commercial CFD software that has the function of automating the process of optimizing die geometry on the market, such as Polyflow (Ansys, 2019) and PolyXtrue (Plastic flow, 2019), however the cost of these software is in the range of 50,000 US dollars for a single license thus negating the possibility for an economic solution to this problem.

During interviews with plastic extrusion experts, they have explained that these optimization software does not reliably provide the perfect solution for complex die profiles and further tweaking or trial runs of the extrusion operation will be required and the overall cost of conducting these runs along with the cost of the software does not make it a feasible option for most companies.

A few papers presented optimization strategies to find the optimal shape of cross-section of die slices with a computerized optimization loop using finite element method (FEM). Volumetric Finite element (FE) analysis had been implemented to optimize the polymer flow through each die cross-section. The profiles are divided into several sample shapes (like rectangular, circular, and annular shapes) called elemental section (ES) as seen in Figure 1.18, and then optimize based on either the length of the parallel zone (Die), the exit thickness of the parallel zone (Die), or the convergence angle from pre-parallel zone to parallel zone for walls with different wall-thickness (Nobrega et al., 2004; Ettinger, 2004). However, this approach for automatic optimization can only be applied on simple profile extrusion die geometry like slits, annulus, circular and square pipes.

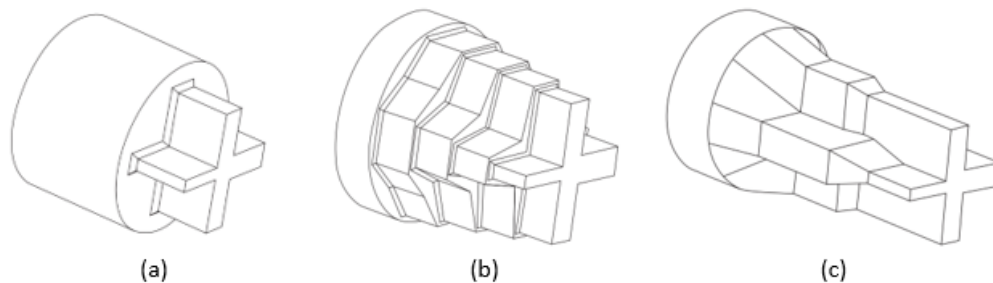
## CHAPTER 2

### DESIGN DEFINITION

#### 2.1 Design of Extrusion Tooling

Plastic profile extrusion is convinced to be the most difficult and the least predictable type of extrusion technologies (Rauwendaal, 2014). Compared to all the other components, the profile extrusion die is the most important part in the entire process. According to Carneiro (2012), there are three types of profile extrusion dies,

1. Plate die: As seen in Figure 2.1(a), plate dies are composed of a plate mounted on the extruder exit which has the desired shape machined. They can be easily manufactured and modified. However, the abrupt change of geometry causes two major drawbacks. The sudden geometry change can lead to stagnation of the polymer material in the die which limit the use to thermally stable polymers only. In addition, this design causes significant dimensional variations and limits the extrusion flow rate which significantly hold back the throughput rate.

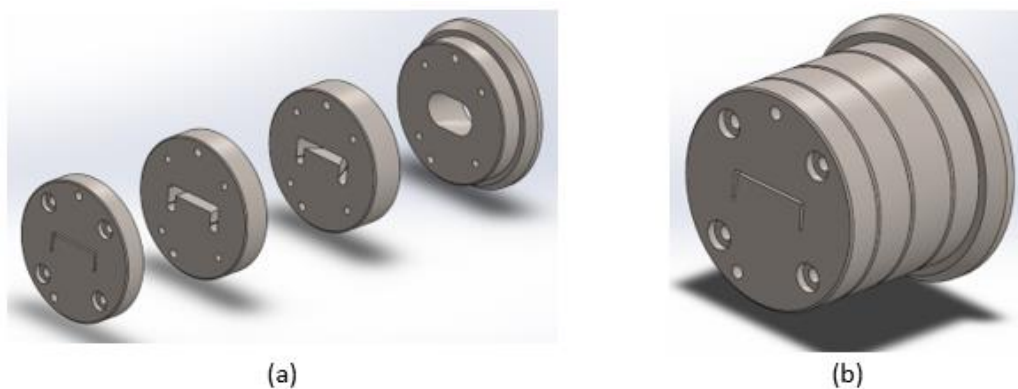


**Figure 2.1** Different types of profile extrusion dies; (a) Plate die, (b) Stepped die, (c) Streamlined die.

Source: Carneiro, O., & Nobrega, J. (2012). Design of Extrusion Forming Tools. Shrewsbury: iSmithers Rapra Publishing

2. Stepped die: As seen in Figure 2.1(b), the flow transition of this kind of dies is much better than plate dies, but there are still stagnation areas at the plate connections which will cause polymer degrading during process.
3. Streamlined die: As seen in Figure 2.1(c), these dies gradually change the geometry from the extruder outlet to the shape of the desired product which prevent both drawbacks of plate dies and stepped dies, but at the same time it cost relatively higher than the other two dies however when it is used for mass production the cost to manufacture the die is very economical due to its advantages.

The streamlined dies can be achieved in an intermediate design of multiple die plates, which is composed of a series of mounted plates, one or more transition plates in transition zone and a die plate with constant cross-section in parallel zone. This multiply-plate die design is currently the most commonly used one in the plastics industry (Lafleur, 2014). Figure 2.2 shows a typical assembly of a multi-plate extrusion die for a U-shaped profile.

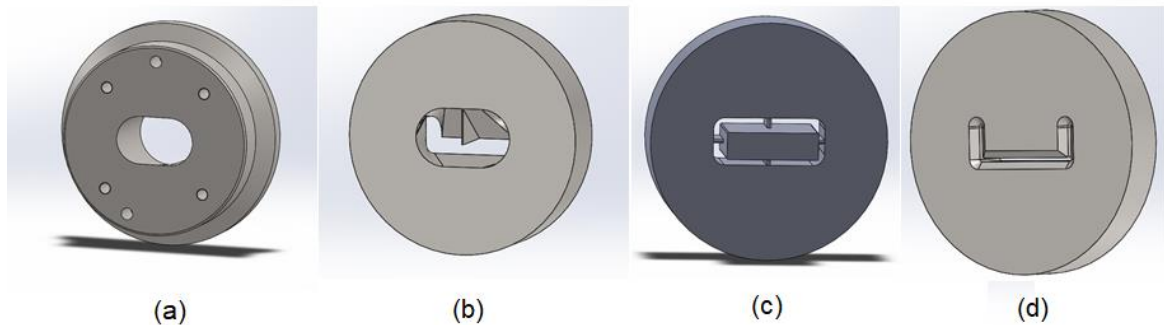


**Figure 2.2** Extrusion die assembly; (a) Exploded view; (b) Assembled view.

Source: Zhang, B., et al. (2017). "Effect of Metal Additive Manufacturing on the Engineering Design of Manufacturing Tooling: A Case Study on Dies for Plastic Extruded Products."

There are multiple plates with unique functions that make up an extrusion die, some of the most common ones are,

- Adapter plate: As seen in Figure 2.3(a), this plate has a counterbore in one side where it will be attached to the extruder and it will house the screen pack and the breaker plate. The main function of the plate is to support the flow of the polymer into the die and will always have a round inlet profile to match the diameter of the extruder outlet.



**Figure 2.3** (a) Adapter plate; (b) Transition plate; (c) Spider plate; (d) Die plate.

Source: New Jersey Precision Technologies

- Transition plate: As seen in Figure 2.3(b), this plate can either be round or rectangular depending on the specification provided by the customer. It will have an entrance and exit geometry that are different by size, scale and shape. In the case of open profiles, there will be ribs in the back of the transition plate to improve flow. Additional transition plates will be used in cases where a large transition zone is required.
- Spider plate: As seen in Figure 1.16(c), this plate is only used in the cases for hollow extrusion such as a round or square shaped tube. It consists of a mandrel held by a plate using the spiders. The mandrel is found on the exit side and the bullet is located at the inlet of the plate. The bullet and the mandrel can either be integrated or can be removable depending on the preference of the customer.
- Die plate: As seen in Figure 1.16(d), this plate contains features that account for the post extrusion effects like drawdown and shrinkage, that happen when the extruder

passes through the die and can be the most important plate in the assembly. This plate usually has a lead-in feature milled on the inlet side of the plate to allow for a more streamlined flow of polymer into the plate.

There are basically two main points to consider when designing a profile extrusion die: how to make the flow distribution through profile more uniform, and how to anticipate part geometry after extrusion (Carneiro, 2012). Although there are some researches about the latter one (Pauli et al., 2012; Liang et al., 2004; Brown, 2000 and Arda, 2005), the former one is considered as the most influential to the performance of an extrusion die profile, and this is always the stressed point that many researchers focusing on (Shahreza, 2010; Nobrega, 2012; Yilmaz, 2014 and Rajkumar, 2017). In order to solve the issue of flow balancing, two main strategies have been used:

- Minimizing the differences between local and mean velocities.
- Minimizing the differences between the local mass flow rate and the intended local mass flow rate

The possibility and approaches of automating the optimizing process of profile extrusion die have been considered and researched on by many researchers, and there is some commercial CFD software have the function of automating the process of optimizing die geometry on the market, such as Polyflow and PolyXtrue. Ettinger (2004), presented optimization strategies to find the optimal shape of cross-section of die slices with a computerized optimization loop using finite element method (FEM). Finite element (FE) analysis has been implemented to optimize the polymer flow through each die cross-section (Nobrega, 2012). There are few groups working on the design optimization researches based on the parameters of geometrical dimensions of PPZ and PZ. The approaches are

very similar; the profiles are divided into several sample shapes (like rectangular, circular, and annular shapes) called elemental section (ES), and then optimize based on either the length of the parallel zone (Die), the exit thickness of the parallel zone (Die), or the convergence angle from pre-parallel zone to parallel zone for walls with different wall-thickness (Carneiro, 2012). However, this approach for automatic optimization can only be applied on simple profile extrusion.

### 2.1.1 Extrusion Tooling Design at NJPT

Extrusion tooling is responsible for forming the high temperature polymer melt, coming out of the extruder, into the desired extruded shape. The design of extrusion tooling begins with collecting necessary input parameters which will be used to establish constraints for the overall design process as shown in Figure 2.4. These constraints have been developed by NJPT engineers based on experience and analysis of historical work records.



**Figure 2.4** Overall work flow for design of extrusion tooling.

Source: New Jersey Precision Technologies

Once the input parameters have been obtained, this information is used to modify the dimensions of the customer provided product profile to design an exit profile such that the extrudate that finally comes through it will have the desired geometric dimensions.



Using the obtained exit profile, the inlet profile is designed and features like flow restrictors and lead-in is included if required.

Next the extruder machine outlet and the design input parameters are used to design the adapter plate. The adapter plate plays a major role in the overall extrusion tooling design. The design for transition plate can only be performed after the designing the adapter plate, since it forms the intermediary channel through which the extrudate will flow from the adapter plate, into the die plate. Moreover, the screw pattern on the adapter plate, if provided by the customer, will be responsible to determine the location of screw holes for all the other plates.

Once the plates are designed, drawing sheets for individual plates are created. To make the drawings a medium of standard design communication between all the departments of NJPT, a set of standard layers have been established and the appropriate geometric features in the designs are assigned them accordingly.

#### **2.1.1.1 Design Input Parameters**

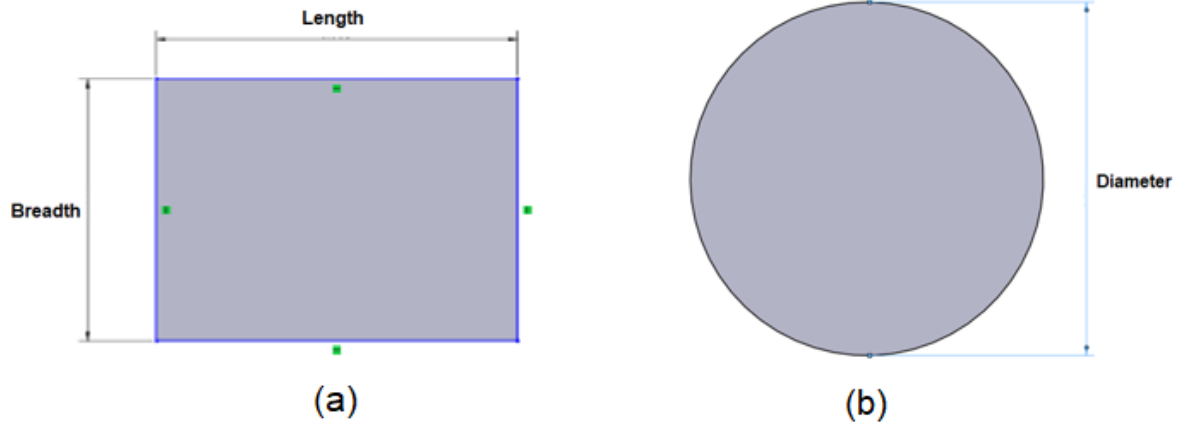
These parameters have to requested from the customer and in case the customer does not provide any particular one, a suitable value will be provided by our engineers based on the other inputs and past experience.

1. Desired product profile (In DXF format)
2. Extrudate – Polymer undergoing extrusion
3. Wall thickness adjustment percentage
4. Drawdown adjustment percentage
5. Type of lead-in and dimensions
6. Leg extension and flare distances
7. Flow restrictor diameter

8. Adapter blank diameter
9. Extruder outlet diameter
10. Adapter outlet profile – Round, rectangular, hourglass or slot
11. Die blank shape – Round or Rectangular
12. Die blank dimensions – Diameter or length and breadth
13. Adapter screw hole pattern (Optional)
14. Adapter screw hole size
15. Die screw hole pattern (Optional)
16. Die screw hole size
17. Dowel size

#### **2.1.1.2 Blanks**

Blanks are steel plates through which the extrudate channel is subtractively manufactured using methods like WireEDM and milling. The blank can either be round or rectangular, as shown in Figure 2.5 (a) and (b), depending upon the geometry of the product profile and the choice of the customer since some customers will have existing extrusion tooling equipment that are blank geometry specific and can only be used with the appropriate shape of the blank either round or rectangular. The material of the blank is usually a stainless-steel alloy ranging from 420, 416 or 410. Cold rolled steel or 4140 steel has also been used to manufacturing blanks for extrusion tooling.



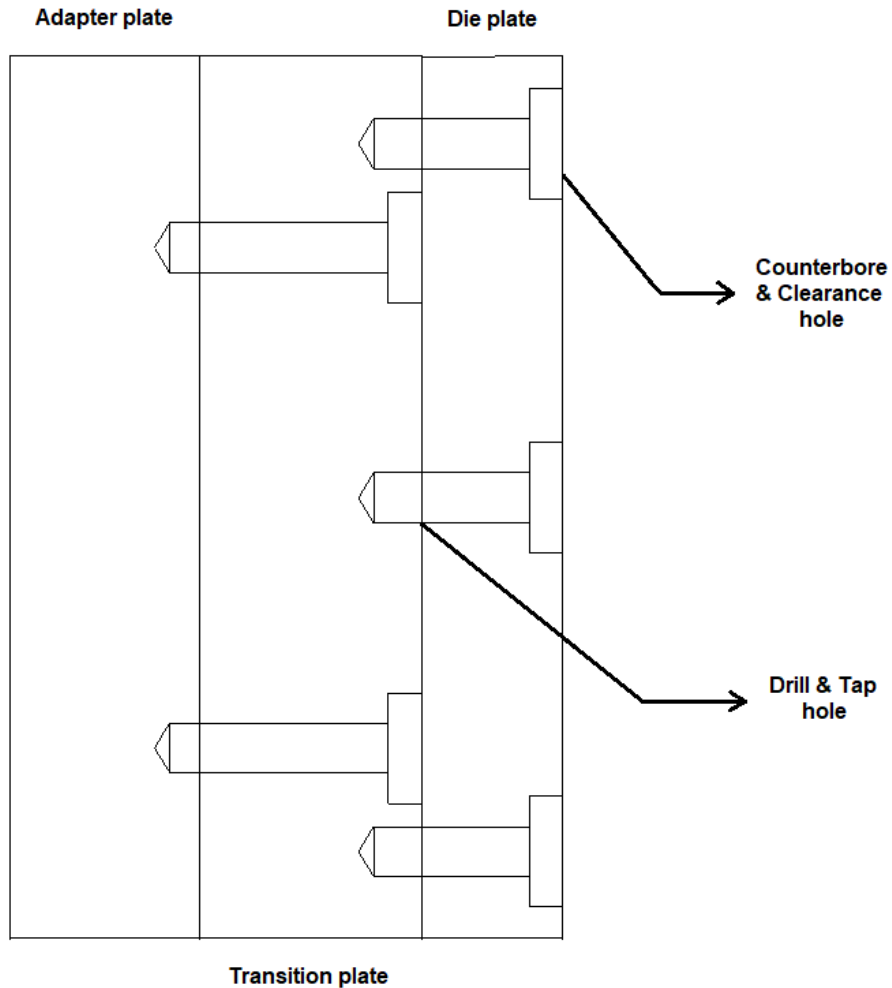
**Figure 2.5** Types of blanks, (a) Rectangular blank, (b) Round blank.

Source: New Jersey Precision Technologies

The adapter plate will always be a round blank whereas the die and the transition plate can either be round or rectangular based on customer preference. However, both the die and the transition plate will have the same shape or in other words, if the die blank is chosen to be rectangular then, the transition blank will also be rectangular and vice versa.

### **2.1.1.3 Screw Holes and Dowel Holes**

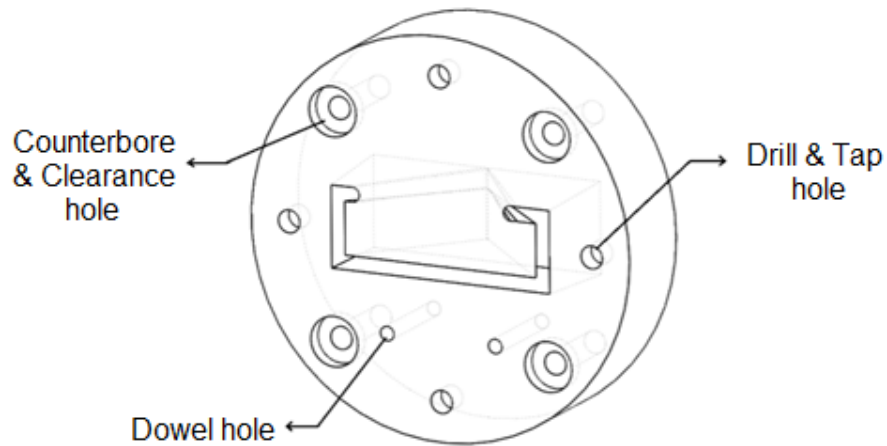
Screw holes are necessary in the overall extrusion tooling design as they are required for the plates to be held together. The adapter plate gets mounted on to the extruder outlet mostly using a clam mechanism. As shown in Figure 2.6, socket head screws are used to connect transition plate to the adapter plate and similarly screws are used to connect the die plate onto the transition plate.



**Figure 2.6** Extrusion plates held together with socket head screws.

Source: New Jersey Precision Technologies

The screw pattern on the adapter plate will be the key information required to design the pattern for the transition and the die plate since the screws must not have interference with each other. The die plate will have counterbore and clearance holes of a customer specified size and will be aligned to drill and tap holes located on the transition plate. The transition plate will also house counterbore and clearance holes to align with the drill and tap holes located in the adapter plate as shown in Figure 2.7.



**Figure 2.7** Types of holes found on a transition plate.

Source: New Jersey Precision Technologies

If the customer recommends us to design holes for all the plates, the routine is quite straightforward however, in the case where a customer does not require holes for a specific plate or two, the design routine will be selected based on Table 2.1.

**Table 2.1** Hole Design Routine Where 0 = No Holes and 1 = Holes Are Required

Adapter Holes	Trans Holes	Die Holes	Type of Holes
0	0	1	CB & CL on Die
0	1	0	No holes on any plate
0	1	1	CB & CL on Die, DRL & TAP on Trans
1	0	0	DRL & TAP on Adapter
1	0	1	DRL & TAP on Adapter, CB & CL on Die
1	1	0	DRL & TAP on Adapter, CB & CL on Trans
1	1	1	DRL & TAP on Adapter, CB & CL on Trans, DRL & TAP on Trans, CB & CL on Die

Source: New Jersey Precision Technologies.

In the table, CB & CL stands for Counterbore and Clearance hole; and DRL & TP stand for Drill and Tap hole. The standard diameters and depth of different hole sizes used at NJPT can be found in Table 2.2.

**Table 2.2** List of Hole Sizes Used for Extrusion Tooling

<b>Size</b>	<b>Drill &amp; Tap</b>	<b>C' Bore &amp; Clearance</b>
<b>1/4-20</b>	0.203 x 0.625 DP	0.265 x * DP
	1/4 - 20 TAP x 0.50 DP	0.437 C'BORE x 0.37 DP
<b>5/16-18</b>	0.257 x 0.750 DP	0.328 x * DP
	5/16 - 18 x 0.63 DP	0.531 C'BORE x 0.44 DP
<b>3/8-16</b>	0.313 x 0.875 DP	0.390 x * DP
	3/8 - 16 x 0.75 DP	0.625 C'BORE x 0.50 DP
<b>1/2-13</b>	0.422 X 1.000 DP	0.515 x * DP
	1/2 - 13 TAP x 1.25 DP	0.813 C'BORE x 0.62 DP

Source: New Jersey Precision Technologies.

Dowel holes are created on the plates to ensure perfect alignment of all the plates with each other. The die and the adapter plate will have slip fit holes so the dowel can easily slide through however, the transition plate will have tap fit holes. Dowels will be located between the die and the transition plate as well as between the transition and the adapter plate. Commonly used dowel hole sizes for extrusion tooling by NJPT have been listed out in Table 2.3.

**Table 2.3** Commonly Used Dowel Sizes for Extrusion Tooling Plates

Nominal Size	Nominal Pin Diameter	Tap Fit Diameter	Slip Fit Diameter
<b>1/4</b>	0.2500	0.2502	0.2510
<b>3/8</b>	0.3750	0.3752	0.3760
<b>1/2</b>	0.5000	0.5002	0.5010

Source: New Jersey Precision Technologies.

## **2.2 Audit of Extrusion Tooling Design Process at NJPT**

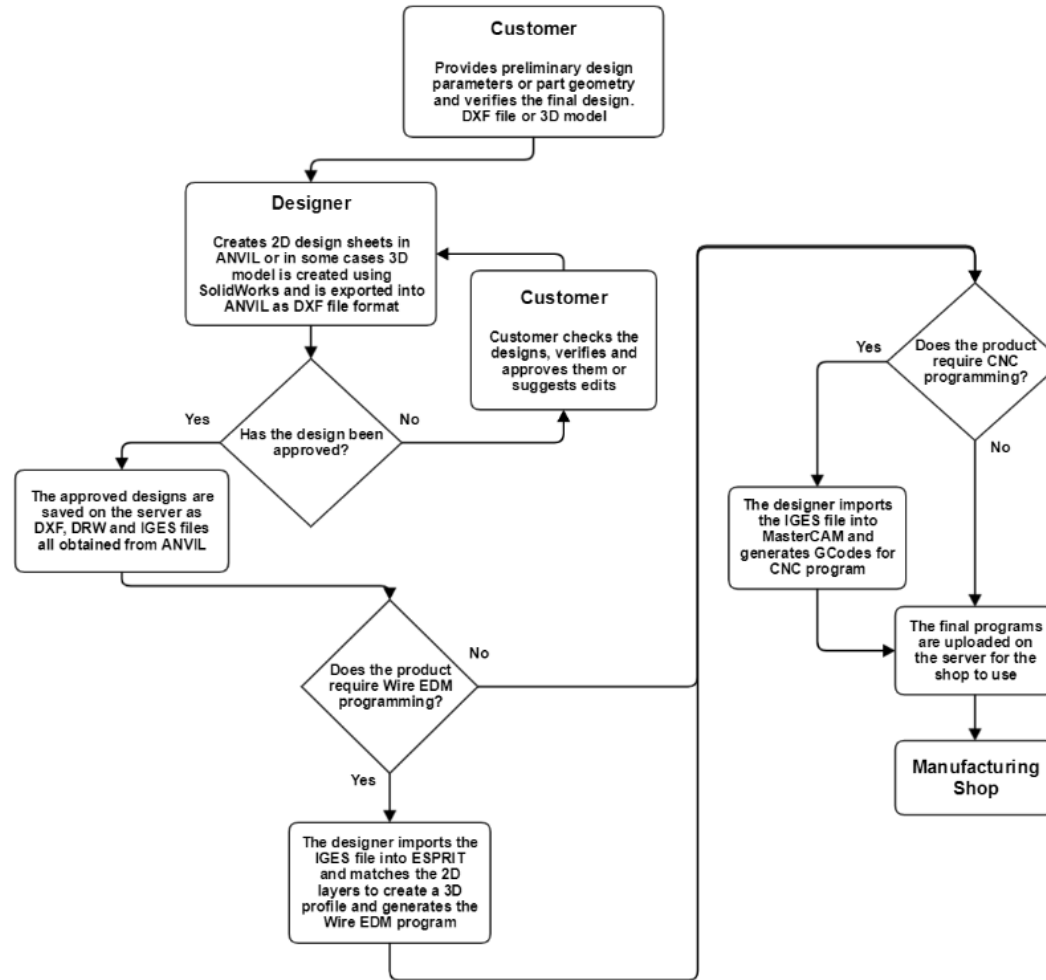
NJPT has successfully designed and manufactured a large amount of extrusion tools for over more than a decade. The following audit describes the methods used to determine various parameters that make up the die plate, transition plate and the adapter plate for an open extrusion profile. At NJPT, extrusion dies are designed in a reverse engineering manner where the process begins from the final desired exit geometry of the extruded profile. This exit profile dimensions along with extruded machine specifications are used to design all the individual plates that make up the profile extrusion die tool set.

The software and tools used for designing extrusion dies at NJPT are, ANVIL-1000MD, this is a simple 2D CAD drafting software that hosts a variety of customizable toolbars which allows very quick customization and generation of drawing sheets with multi-level layer support; ESPRIT, this is a CAM software that is used to create WireEDM programming; MasterCAM, another CAM software mainly used to create CNC programming. Other custom proprietary programs are also in use that helps determine hole locations from a particular layer in drawing sheets and programs the EDM machine how to drill it. Manufacturing constraints are kept in mind throughout the design and are used to determine parameters of the tools during the initial design stage process.

The design of extrusion tooling at NJPT is undertaken by the engineering department and their overall process flow can be seen in Figure 2.8. The process flow includes work flow of the team in the computer aided-design stage as well as preparing the programs for manufacturing with the help of computer aided manufacturing software. The process begins with the customer providing the team, a part geometry design of the final desired outlet shape that they require. Most of the time this part geometry will be in .DXF (Drawing Exchange Format) or as a 3D model.

Once the desired extruded part geometry has been obtained from the customer, the designers import the file into ANVIL-1000MD and using design processes explained in the next chapter, creates drawing sheets for the die, transition and adapter plates and submits them to the customer for design approval. Next, if the product has features that require WireEDM, it will be imported in ESPRIT CAM software and a proper toolpath will be programmed. Similarly, if CNC machining is required, the same is done in BOBCAD/CAM. Once the programs have been postprocessed for the manufacturing machines, the designs are forwarded to the next department, manufacturing.

















**Figure 2.8** Overall workflow depicting concept to final product design followed by NJPT.

Source: New Jersey Precision Technologies

### 2.2.1 Layer System

The design output will be a drawing sheet containing all the details regarding the tool to be manufactured. The designs made at NJPT makes use of a feature called layers within which groups of sheet elements are placed such that it becomes easier for manufacturing processes to interact with them. For example, all the holes represented in the drawing sheet will be on level 20 so that the post processing software will be able to directly read the drawing sheet and determine the coordinate locations to create corresponding G-Code and M-Code for the machine.

Each individual layer is represented by a color code which is used to color the corresponding segments that belong in them. These color codes are used by both the design and manufacturing team at NJPT and this system is vital for maintaining an efficient workflow within the company. Figure 2.9 shows the commonly used layers, their color codes and the meaning they represent.

Name	Description	
0	Misc	
40	Title Block	
41	Title Block	
42	Title Block	
9	Dimensions	
10	Straight Wire (No Flow Restrictors)	
20	CNC Holes	
31	Boundary	
50	Plate Exit Profile	
51	Plate Inlet Profile	
100	BOBCAD Path	

**Figure 2.9** Various layers shown with their name and the description of the segments contained within them.

Source: New Jersey Precision Technologies

### 2.2.2 Knowledge Base

On completion of every successful design, all the geometric and non-geometric information regarding the produced extrusion tool is collected into an excel database as seen in Figure 2.10. This database contains experiential information that are known to work and the conditions are often found to be repeated when manufacturing different tools with the same material conditions or profile geometry.

Traditionally certain parameters that are crucial to determine the geometry of extrusion plates were obtained through various techniques of trial and error however, designers at NJPT make use of this knowledge base to quickly determine what the possible range of values make sense for the particular design. Since the knowledge base keeps getting populated with more information after every successful design, the accuracy of delivering valid parametric information increases the more in depth it gets.

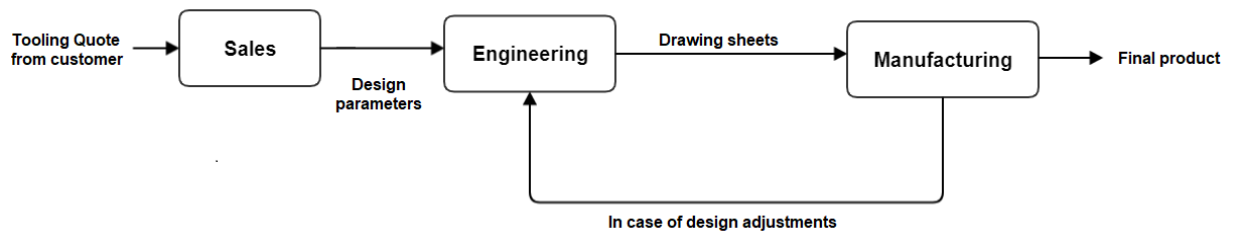
<u>AdjustedProfileOverallLen</u>	<u>AdjustedProfileOverallHgt</u>	<u>AdjustedProfileWallThickness</u>	<u>Drawdown</u>	<u>WallAdjustment</u>
1.15	0.496	0.036	0.08	0.15
1.15	0.496	0.036	DD	0.15
1.15	0.496	0.036	0.08	0.15
1.15	0.496	0.036	0.08	0.15
1.58	0.25	0.0402	0.12	0.08
2.94	1.426	0.49	0.1	0.1
3.971	1.51	0.081	0.25	0.08
3.971	1.51	0.081	0.25	0.08
3.971	1.51	0.081	0.25	0.08
3.971	1.51	0.081	0.25	0.08
1.58	0.25	0.0402	0.12	0.08
1.58	0.25	0.0402	0.12	0.08
1.58	0.25	0.0402	0.12	0.08
1.58	0.25	0.0402	0.12	0.08
1.421	0.1329	0.0489	0.15	0.08
1.421	0.1329	0.0489	0.15	0.08

**Figure 2.10** A small portion of the knowledge base containing experiential data of parameters used to design extrusion tooling.

Source: New Jersey Precision Technologies

### 2.3 Audit of Extrusion Tooling Manufacturing Process at NJPT

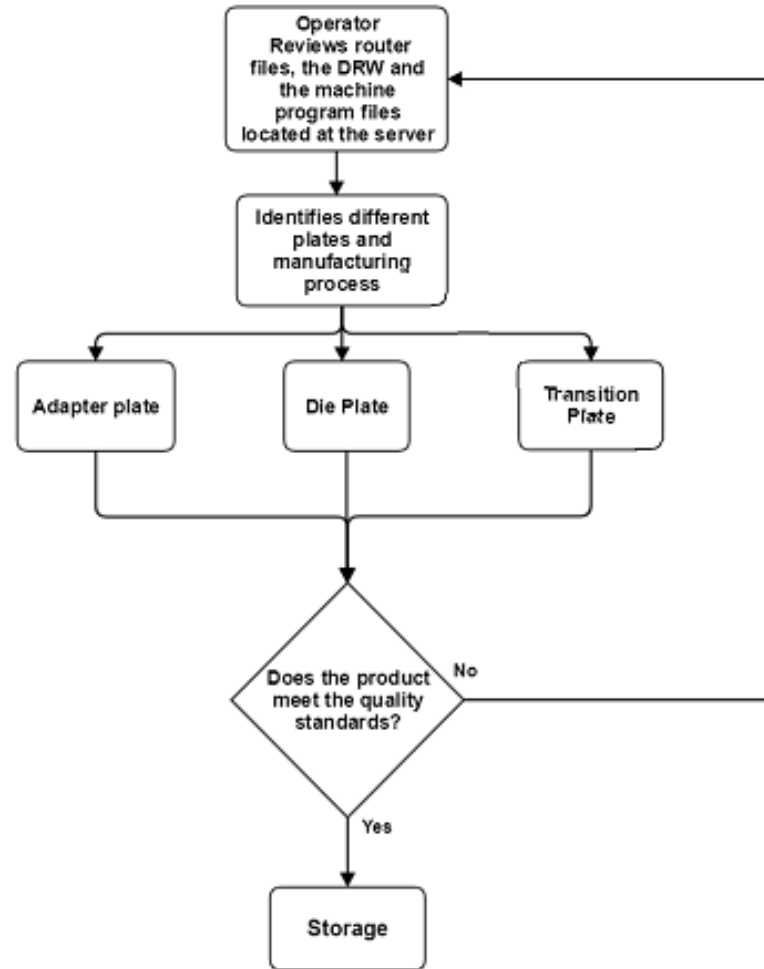
New Jersey Precision Technologies houses state of the art machines for manufacturing extrusion tools. Figure 2.11 shows the inter-relationship between engineering and manufacturing departments at NJPT and the inputs and outputs of each department.



**Figure 2.11** Inter-relationship between the engineering and manufacturing team at NJPT.

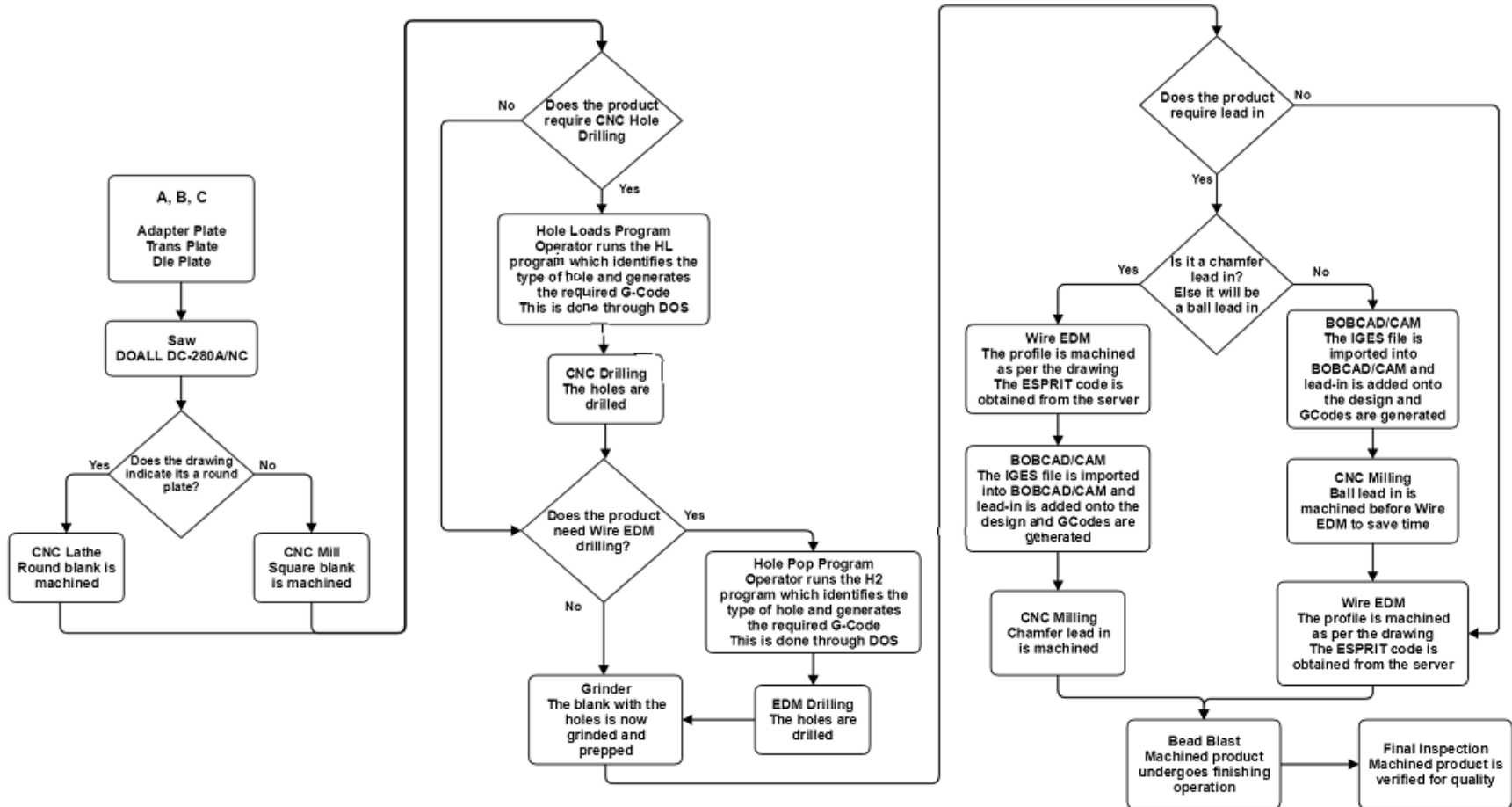
Source: New Jersey Precision Technologies

It can be seen from Figure 2.12 that, once the operator working in the manufacturing station obtains the router files for a particular extrusion tooling job, they extract the drawing sheets and the CAM program stored in the cloud server corresponding to the respective job that was earlier created by the design team at engineering. The operator then identifies the different plates required as per the router sheets and performs manufacturing processes as seen in Figure 2.10. After the product has been manufactured it is sent for quality inspection and once all the standards and the specifications are met, they are stored securely till the next customer delivery window.



**Figure 2.12** Operating work flow of manufacturing extrusion tooling.

Source: New Jersey Precision Technologies



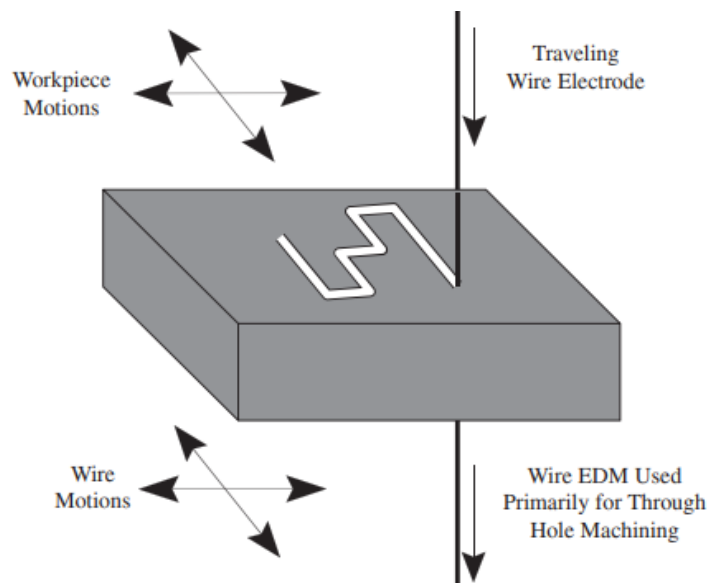
**Figure 2.13** Workflow diagram showing manufacturing processes used for producing extrusion tooling plates.

Source: New Jersey Precision Technologies

### 2.3.1 Electrical Discharge Machine

EDM is a popular subtractive manufacturing method that is used in manufacturing extrusion tooling. It has dramatically improved the manufacturing industry through accuracy, quality, productivity and earnings (Guitrau, 1997). Any material that conducts electricity is compatible to be used in the EDM machine. Material is removed from the workpiece by allowing it to come into contact with an electrode thereby creating an electrical discharge in the form of sparks. There are three common methods of EDM,

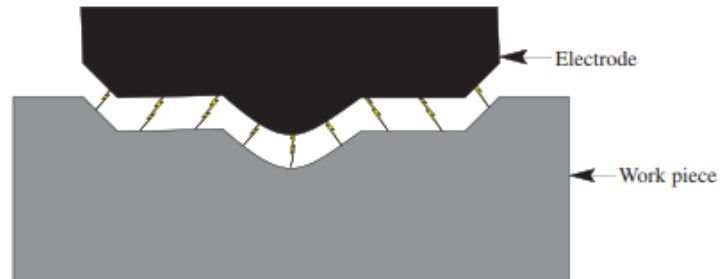
- Wire EDM: As seen in Figure 2.14, the electrode is a thin wire that is used to erode the metal when it comes into contact with the workpiece. It is highly accurate and can be used to make intricate subtractive designs. However, since the erosion is done along the path of the line, it is impossible to manufacture curved surfaces through this method.



**Figure 2.14** Wire electrical discharge machine showing contact between electrode and workpiece.

Source: Guitrau, E. (1997). The EDM handbook . Cincinnati: Hanser Gardner Publications..  
[http://www.reliableedm.com/Complete%20EDM%20Handbook/Complete%20EDM%20Handbook\\_2.pdf](http://www.reliableedm.com/Complete%20EDM%20Handbook/Complete%20EDM%20Handbook_2.pdf),  
accessed July 1, 2019

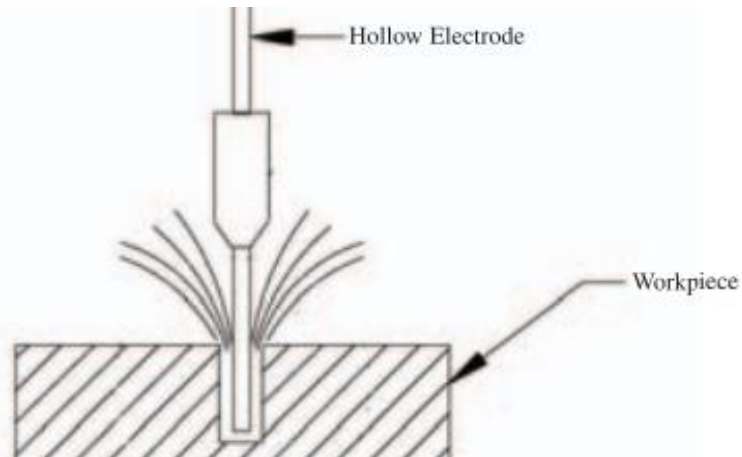
- Ram EDM: This method can also be referred using the following names, sinker EDM, die sinker, vertical EDM, conventional EDM and plunge EDM. This method is mainly put into use when there is a need for cavities in the workpiece as shown in Figure 2.15. It consists of a ram electrode which will come into contact with the workpiece and remove the material.



**Figure 2.15** Ram EDM used to create cavity on the workpiece.

Source: Guitrau, E. (1997). The EDM handbook . Cincinnati: Hanser Gardner Publications..  
[http://www.reliableedm.com/Complete%20EDM%20Handbook/Complete%20EDM%20Handbook\\_2.pdf](http://www.reliableedm.com/Complete%20EDM%20Handbook/Complete%20EDM%20Handbook_2.pdf),  
 accessed July 1, 2019

- Small hole EDM: Also known as hole popping machine or start hole EDM drilling. It makes use of a hollow electrode as seen in Figure 2.16 to drill holes on the workpiece.



**Figure 2.16** Hole Popper used to create small holes on the workpiece.

Source: Guitrau, E. (1997). The EDM handbook . Cincinnati: Hanser Gardner Publications..  
[http://www.reliableedm.com/Complete%20EDM%20Handbook/Complete%20EDM%20Handbook\\_2.pdf](http://www.reliableedm.com/Complete%20EDM%20Handbook/Complete%20EDM%20Handbook_2.pdf),  
 accessed July 1, 2019



## 2.4 Automation Platform

### 2.4.1 Scope for Automated Extrusion Tooling Design

After discussions with the engineering team of New Jersey Precision Technologies and taking into account considerations regarding duration of project and resources, the following scope was laid out. This scope has been confirmed by the team at New Jersey Precision Technologies that it matches to about 90% of their upstream plastic extrusion tooling design.

1. This tool will currently only support die design for single extrusion
2. Currently supports open channel profiles only and will not automate design of the spider plate.
3. Up to maximum of two transition plates will be automatically designed.
4. Will support any open profiles with a maximum overall dimension of 8 inches, beyond which additional transition plates or drop off plate might be required.
5. Final output drawing sheet will require ribs to be added on the last plate, since locating the ribs involve a higher level of intelligence and profile understanding.
6. Vacuum Calibrators and other cooling tools will not be created in this version but will be a part of the future versions.

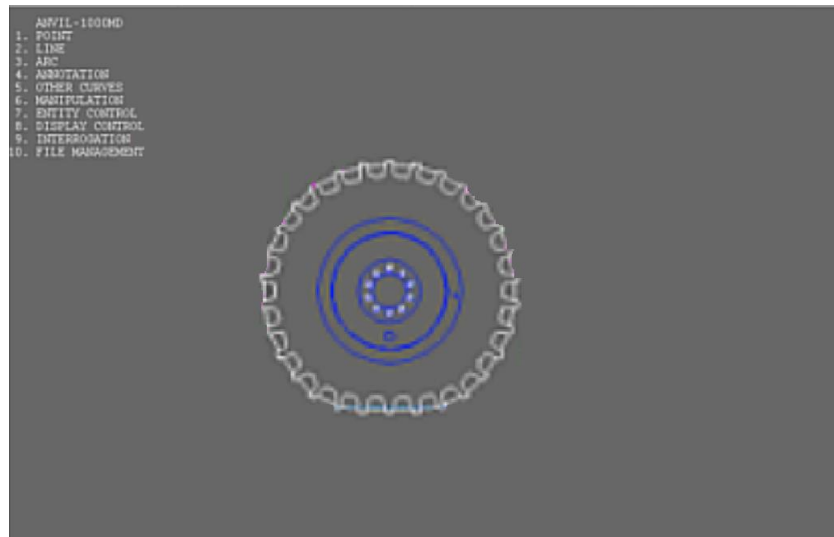
The input for this system will be a customer product profile and it must satisfy the following conditions,

1. File format has to be .DXF
2. The profile should have a scale of 1:1
3. The input file should only contain the profile and no annotations or dimensions.

## 2.4.2 Automation Platform Selection

The audit of the design and manufacturing department regarding the workflow of producing extrusion tooling helped us understand the inter-relationships and we will be better equipped to select a platform that will be capable of performing design automation and one that will not hinder the current workflow at NJPT. The main CAD software used for designing all the detailed drawing for extrusion tooling was ANVIL-1000MD®.

ANVIL-1000MD® is a two-dimensional CAD software system that is capable of creating drawing sheets in a simple environment. It is a highly simplistic tool with a compact menu structure which designers can get used to and improve their productivity. Figure 2.17 gives an idea regarding the user interface of this software.



**Figure 2.17** Front-end user interface of ANVIL two-dimensional CAD software.

Source: ANVIL1000MD®. Retrieved July 1, 2019, from <http://www.anvil1000md.com/about-anvil/>

However, the main drawback was that it did not support a possible platform for automation because the drawings created in ANVIL were not parametric, rather it followed

a draw as you go approach. There was no functionality to modify the distance between segments, add relations between them or perform any parametric modifications within the software. As seen in Figure 2.8, the workflow requires the final detailed design to be in either DXF, IGES or DRW, the automation platform to be selected has to support creating drawing sheets in either of the mentioned file formats.

As explained during the extrusion tooling design audit, another important factor that is key to the workflow of production in NJPT was that certain features of the drawing sheet have to be in particular layers for the CAM and post processing software to recognize. The two possible software solutions that supported these requirements were DraftSight and SolidWorks.

DraftSight is created by Dassault Systems and is promoted as a CAD package that allows editing and viewing 2-D drawing files. It has the ability to assign geometry into different layers. It allows DXF files to be imported while preserving its layer information. It allowed possibility for automating design tasks using script files, lisp routines and had a built-in macro recording in its PRO version. The software would work well within the NJPT current work flow and the design team had previous training to use this software efficiently. However, this software had the following drawbacks,

1. DraftSight is not parametric and once segments have been created, their parameters like dimensions, relations etc. could not be modified.
2. Reading and writing information from an excel database was not easy to do.
3. Even though it claimed to have a macro recorder, there was no compiler built into the software and thus the automated script code would have to be run from another additional platform like Microsoft Office or VBStudio.

The next option in the list was SolidWorks which is also created by Dassault Systems however this is promoted as a highly functional parametric software that allows editing and creating three-dimensional files. SolidWorks allowed creating two-dimensional drawing sheets, had an in-built hole wizard capable of creating standing holes and provides customers with a better view and outline of how the final product will look like. Solidworks also has the functionality of an in-built API (Application Program Interface) that allowed automating the entire design process as well as allowed integration with databases to read and write parametric information from a design.



**Figure 2.18** API help page within SolidWorks showing a function and its parameters.

Source: SolidWorks. Retrieved July 1, 2019, from <https://help.solidworks.com/2019/English/api/sldworksapiproguide/Welcome.htm>

SolidWorks includes capability of creating three-dimensional designs which could be a possible upgrade to the automation system in the future since currently the scope of this project is to generate two dimensional drawing sheets in such a way that it can be used by the CAM and post-processing software to generate programs for the manufacturing machines to begin production. SolidWorks API is an interface that is built into the CAD software which allows programmers to utilize API functions to manipulate and perform tasks that designers use to create their designs.

If we are able to identify the required parameters and provide suitable values, we can use the API to easily use functions built-in SolidWorks to generate the desired design using lines of code rather than manual design procedures. Currently SolidWorks supports programming in C++, VB, .NET, VBA and C#. One of the future goals is to completely automate the design as well as automatic generation of program to drive manufacturing through CAM software. The currently used CAM software at NJPT are, ESPRIT by DP Technologies for Wire EDM programming, MasterCAM by CNC Software Inc. and BOBCAD/CAM for CNC programming. VBA backend programming and API support is available for ESPRIT and MasterCAM which will allow us to automate the CAM program generation along with automated CAD. Since VBA is a windows native language it also supports connections to Microsoft software like Word and Excel which will allow us for easy storage of parameters in either a database or word format. Considering all the reasons, pros and cons, the platform selected to automate the design of extrusion tooling was selected to be SolidWorks.

## CHAPTER 3

### TASK DIFFERENTIATION AND WORKFLOW GENERATION

#### 3.1 Task Differentiation

The audit of extrusion tooling design and manufacturing at NJPT led us to understanding the overall workflow of manufacturing extrusion tooling from the customer to the final product. Within the design phase, several steps that are involved in the design process are repeatable tasks done manually by the designers. The repeatable design routines are varied only by the value of the parameter that is used, while their process flow remains the same. For example, to adjust the profile for post extrusion effects, the same set of design steps are taken for all extrusion profiles and only the value of the parameters used differ. However, there does exist methods involved in the design process that requires creative decision making to determine the location on an extrusion profile where certain processes will be performed.

Automation as defined earlier is the technology used to execute repeatable tasks and can be used in the field of design since there are many methods that involves steps which are repeated for every iteration. It can be used as a tool by the designers at NJPT to create an extrusion tooling design for the die, adapter and transition plates up to a point where the designers will only have to spend their resources in doing steps that involve complex decision making and validating the final results. The steps that require human decision making can only be done automatically with the introduction of machine learning and thus it is paramount to identify the list of design procedures that are Formula-Based and Experiential. This will be the stepping stone that is going to define the workflow for

programming the automated expert design system. All the design steps were studied and their categorization into Formula-Based have been described in Table 3.1 and Experiential have been shown in Table 3.2.

**Table 3.1** Formula-Based Methods Found in Extrusion Tooling Design


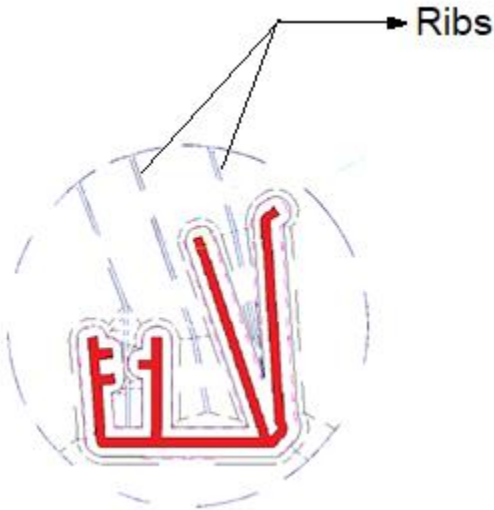
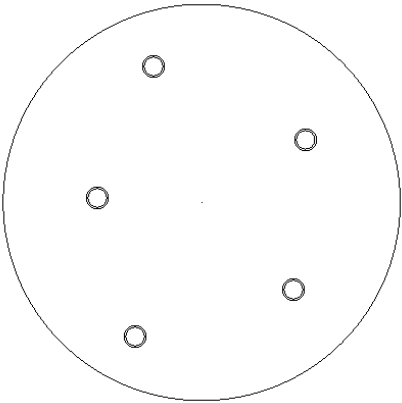
S.No	Formula-Based Methods	Description	Calculation process
1	Initial profile adjustments	To account for the post-extrusion effects, the profile has to be adjusted for drawdown and wall-thickness. The final dimensions of the profile after undergoing these adjustments can be determined formulaically	Refer 3.2.2
2	Leg modifications	In order to allow better flow of polymer into the ends of the profile having legs, the dimensions of the legs may have to modified by adding flares and/or extensions to them. These dimensions are calculated using a formula-based approach.	Refer 3.2.3
3	Flow restrictor	Flow restrictors are necessary at the joints of the profile in order to regulate the speed of extrudate flow through the profile due to varying wall thickness at the joints. The diameter of these flow restrictors are dependent of the profile and can be calculated.	Refer 3.2.4

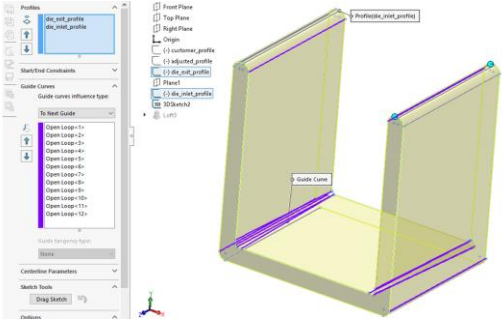


S.No	Formula-Based Methods	Description	Calculation process
4	Lead-In	Lead-in's are features found mostly on the inlet side of the die plate to allow better flow of polymer into the die plate. Depending on the type of lead-in chosen, there exists formulas to calculate the amount by which the profile has to be offset to create a lead-in input.	Refer 3.2.5
5	Locating screw holes and dowel holes.	It is important to determine the exact locations of placing screw holes and dowel holes so that they won't intersect with each other in the assembly.	Refer .3.2.6
6	Adapter profile generic shape dimensions	The dimensions of the generic shape used for the outlet of the adapter plate can be determined formulaically.	Refer 3.3.3
7	Number of transition plates	The number of transition plates will depend on the value of thickness of the transition zone that is determined through a formula-based approach.	Refer 3.4.4

Source: New Jersey Precision Technologies



**Table 3.2** Experiential Methods Found in Extrusion Tooling Design

S.No.	Experiential Methods	Reference Image	Reason
1	Identify where it is relevant to measure wall thickness of profile		Refer 3.1.1
2	Judgement of locating ribs and their dimensions		Refer 3.1.2
3	Predicting hole patterns for adjacent plates if an irregular pattern is supplied by customer		Refer 3.1.3

S.No.	Experiential Methods	Reference Image	Reason
4	Creating guidelines for lofting profiles to interface with manufacturing process.		Refer 3.1.4
5	Identify joints that require flow restrictors		Refer 3.1.5
6	Identify legs that require modification		Refer 3.1.6

Source: New Jersey Precision Technologies

### 3.1.1 Identify Wall Thickness of the Profile

Extrusion profiles come in a variety of shapes and sizes according to their application. The segments of the profile within the DXF file will never follow a standard orientation and when the profile is imported, the entities of the profile will be provided random id numbers thus, to accurately determine two opposite entities of a profile to measure its wall thickness will require the designers to manually select the entities and obtain the shortest distance between them.

### **3.1.2 Judgement of Locating Ribs and their Dimensions**

The designers at NJPT have found that the addition of ribs at the inlet of the first plate (either the feed-head or transition plate) greatly improves flow as well as allows for easy machining in areas where the profile has deep gaps between its legs (requirement for wire EDM process). The ribs aid in creating efficient guidelines from the inlet profile of the first plate, generally a simple circle representing the extruder outlet, to the deep gaps between the profile.

The location of these ribs and their dimensions vary with each extrusion profile and there will never be a unique rib unless the extrusion profiles have similar geometry and shape. Thus, the design of these ribs involves complex profile pattern recognition to determine the exact location and size of the ribs and is usually done by designers based on their experience with extrusion.

### **3.1.3 Design of irregular Hole Patterns**

In some cases, customers that require extrusion tooling will already own existing tools that have hole patterns and these patterns may not always be based on a simple bolt center or rectangular configuration. The location of holes for each plate, especially the transition plate, are interdependent with each other.

The counterbore hole of die plate has to match the appropriate drill & tap hole on the transition and the counterbore & clearance hole on the transition plate has to match the drill & tap on the adapter plate. Since these holes cannot intersect each other, determining the optimum locations for holes for each plate when supplied with a complex hole pattern will require additional level of pattern recognition and decision-making intelligence.

### **3.1.4 Creating Guidelines for Lofting Profiles**

Lofting is a process used by designers to create a 3-dimensional body from one profile to another. However, this can only be performed under the condition that both the inlet and the outlet profile have the same number of segments.

In the case of extrusion tooling profiles, the inlet and the outlet profile for the plates will never have the same number of segments due to addition of flow restrictors, lead-in, leg extensions, flares and ribs. Currently the designers manually pick locations (based on experience) where the profile is split into segments till, they achieve equal number of segments in the inlet and the outlet profile. This process is very vital and requires a large amount of time from the designers because even the CAM software ESPRIT by DP technologies is not capable of automatically identifying guidelines to achieve lofting.

This location selection decision depends entirely on the profile dimensions and shape. Once the locations are determined by the designer, guidelines are created between the start and end point of each segment. Since each and every profile is unique, determining an accurate method of identifying guideline locations require additional intelligence or machine learning algorithms.

### **3.1.5 Identify Joints that require Flow Restrictors**

To improve flow at the joints of any profile, flow restrictors are added to maintain uniform wall thickness. Flow restrictors are only added at the joints of the profile that have a wall thickness greater than the rest of the profile. The identification of these joints are not trivial since extrusion profiles are always unique and designers pick them manually based on experience and recognition of different types of joints.

To automate this process, artificial intelligence will be necessary to accurately predict joint locations based on historical data collected from successful profile designs and by recognizing the pattern and shape of the extrusion profile and determining locations that the algorithm identifies as having larger wall thickness.

### **3.1.6 Identify Legs that Require Modification**

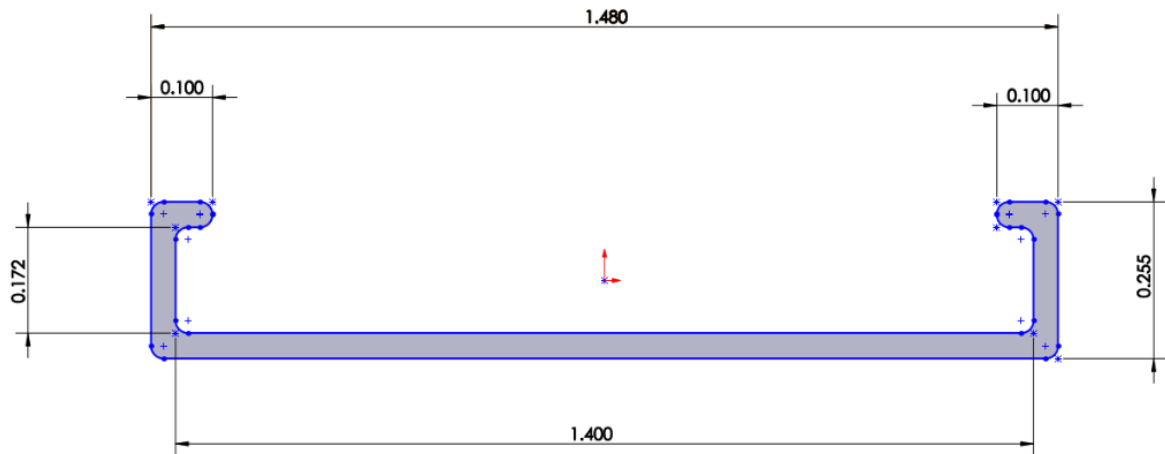
To prevent burning of the polymer especially when using Rigid PVC, the legs of the extrusion profile in the die plate will require its legs to be extended or added with flares or both. Identification of profile features again comes under the domain of pattern recognition and involves complex decision making from the designer.

Currently this project allows the designer to manually select the leg where these necessary modifications are to be performed, however the automatic identification of legs and the modifications that need to be performed can be achieved through machine learning algorithms.

## **3.2 Design Protocol for Die Plate**

Extrusion dies are designed in a reverse engineering manner where we begin our process from the final exit geometry of the finished profile. The best way to describe the design procedure and understand the various steps in the protocol is to create an extrusion die plate for a test profile as seen in Figure 3.1 that meets our scope requirements. To begin automation of the design process it is fundamental to establish a standard operating procedure of the overall design process.

After studying an understanding all the individual steps taken by designers to create extrusion die plates, the following protocol was released and verified by the design team at NJPT. Once the protocol was released, training was conducted within NJPT to ensure all the designers both old and new, were aware of the developed standard operating procedure to design extrusion die, adapter and transition plate.



**Figure 3.1** Sample U-shaped profile selected as product profile for creating extrusion tooling.

Source: New Jersey Precision Technologies

### 3.2.1 Overall Workflow for Design of Die Plate

The design of an extrusion die plate follows a set of key steps that are common for any open channel profile. The first step is to determine the true center of the profile which is important as it will be the point used as reference. Next to account for drawdown, and die swell the profile gets scaled and offset by a certain percentage. If the profile has legs and require flares or extensions added, then the legs will be modified. Next, flow restrictors will be added to the profile at all the joints. The next key step in designing the die plate is

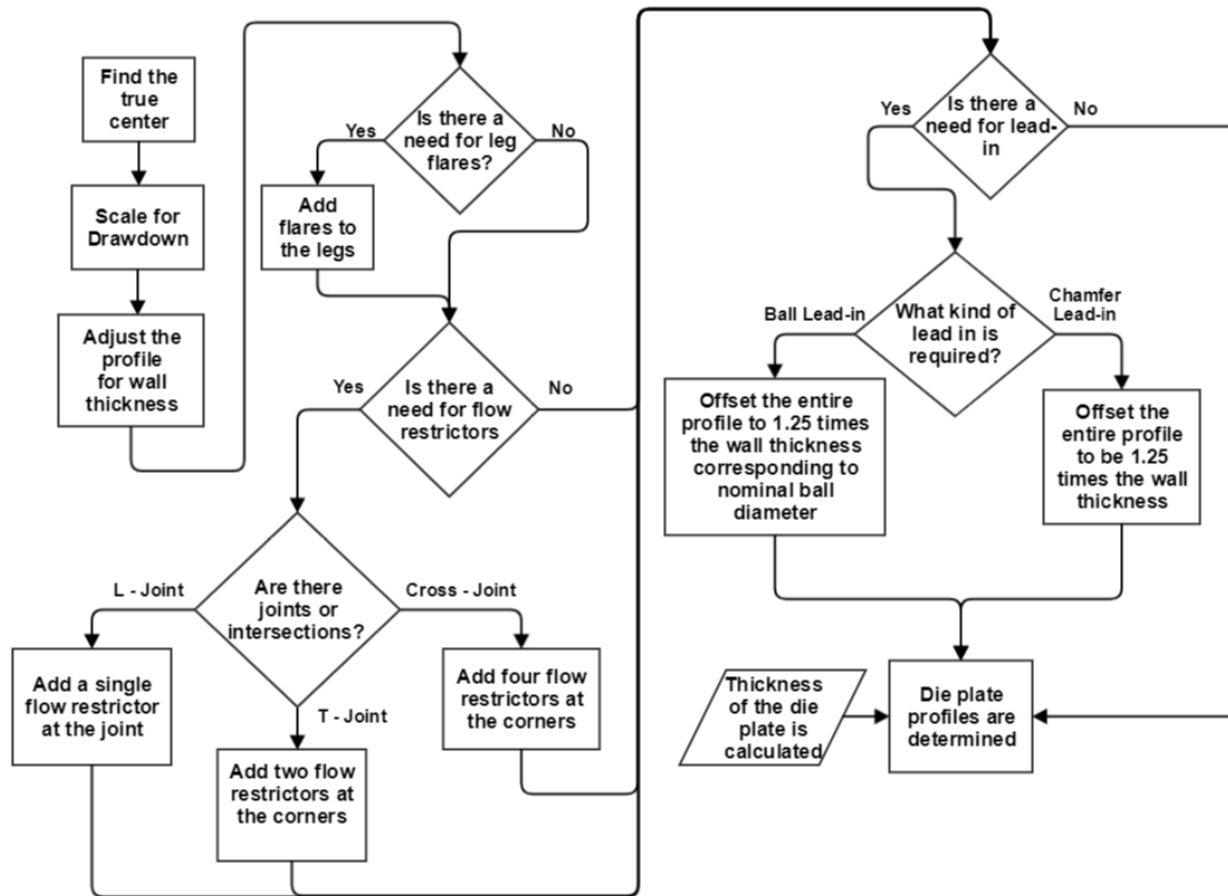
to determine if there is a need for lead-in. Depending on the type of lead-in required, design routines will be implemented.

The exit profile of the die plate will be the profile that has been accounted for drawdown, wall adjustment and leg modifications. The inlet profile of the die plate will be the flow restrictor profile. Each step is further explained below as this is just an overview of the overall design process as seen in Figure 3.3.



**Figure 3.2** Die plate is the highlighted plate in the extrusion tooling assembly.

Source: New Jersey Precision Technologies



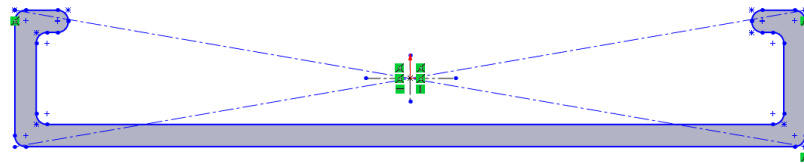
**Figure 3.3** Overall workflow describing the decisions taken to design an extrusion die plate.

Source: New Jersey Precision Technologies



### 3.2.2 Profile Adjustments

The first in the process of designing extrusion die plate for any open channel profile is to determine its geometric true center. This is achieved by connecting lines between the opposite corners of the profile and their intersection point will give us the true center as shown in Figure 3.4. This profile will be assigned to Layer 0 and its line color will be white.



**Figure 3.4** Determining the true center of the product profile.

Source: New Jersey Precision Technologies

Next, the extrudate that comes out from the extrusion die has to be accommodated for the following effects in order to attain the desired geometry,

1. Die swell: The profile of extruded material grows in size, reflecting its tendency to return to its previously larger cross section in the extruder barrel immediately before being squeezed through the smaller die opening.
2. Product cooling shrinkage: Polymers after extrusion undergo geometrical shrinkage due to the normal thermal expansion/contraction caused by heat or cooling.
3. Puller drawdown shrinkage: Product is pulled away from the die and drawn down to its final dimensions by the puller. As the draw increases, the polymer shrinks due to which the extrudate is normally oversized at the die to compensate.

To account for the post extrusion effects, the profile is adjusted so that the final shape geometry obtained after undergoing these effects will be the desired part geometry.

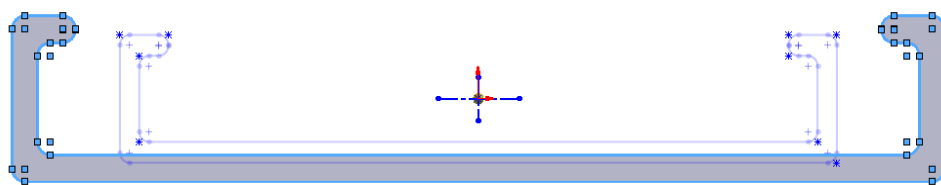
Depending on the material being extruded, the designer will have to select an appropriate value to scale the profile to account for the drawdown effects during extrusion. Drawdown is the percentage difference between the dimensions of the die as designed versus the dimensions of the final part. If there was no drawdown to provide tension, the extrudate will drape and sag when it comes out of the tool and goes for cooling. This value can be obtained either from the customer or from the NJPT knowledge base. Table 3.3 lists out typical drawdown percentage values for commonly extruded polymers. The adjusted profile will be assigned to layer 1 and its line color will be purple. Once we have the value scale the profile up as seen in Figure 3.5, from the true center and the new dimensions for the profile can be obtained using the following formula,

$$\text{New Dim} = \text{Old Dim} \times \left(1 + \frac{\text{DDA}}{100}\right) \quad (3.1)$$

Where,

New Dim = New dimension

DDA% = Drawdown percentage



**Figure 3.5** Scaling the profile to adjust for drawdown effect.

Source: New Jersey Precision Technologies

Wall thickness adjustment percentage is used to account for the die swell phenomenon that occurs after extrusion. The profile is offset inwards as seen in Figure 3.6, using the adjustment value that is determined based on the type of the polymer and the thickness of the profile. Table 3.3 lists out wall thickness adjustment percentage values for common polymers. Using the following formula, the final wall thickness of the profile on the die plate can be calculated,

$$WT_{die} = WT_{initial} \times (1 + WT_{\%}) \quad (3.2)$$

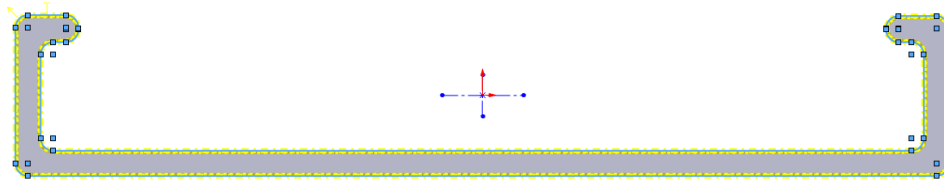
Where,

- WT<sub>%</sub> = Wall thickness adjustment percentage  
 WT<sub>initial</sub> = Initial wall thickness of customer profile before adjustment  
 WT<sub>die</sub> = Adjusted wall thickness used in die profile

**Table 3.3** Drawdown and Wall Thickness Percentage Values for Common Polymers

Polymer	Wall Thickness %	Drawdown %
HIPS	9	30
HDPE	10	40
RPVC	8	20
ABS	10	25
Acrylic	15	28
PETG	15	30
Polycarbonate	10	30

Source: Values based on experiential data from successful design data at New Jersey Precision Technologies.



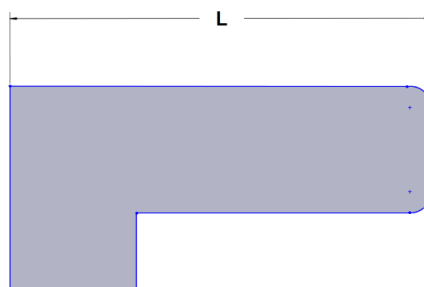
**Figure 3.6** Adjusting wall thickness of the profile to account for die swell.

Source: New Jersey Precision Technologies

This profile has been adjusted for all the possible post extrusion effects based on experiential data and will form the outlet profile of the die plate. This profile will be assigned to layer 50 and its line color will be green.

### 3.2.3 Leg Extensions and Flares

Some polymers have a tendency to flow with low volume at the ends of a profile especially near its legs due to which, the final extrudate will not have retained the desired geometry at the legs and to account for this defect, the profile is adjusted so that flares and/or extensions are added to the legs so that the polymer can flow better without undergoing burning at the corners. The method of adding extensions and flares will depend on the length of the leg,  $L$  as seen in Figure 3.7.



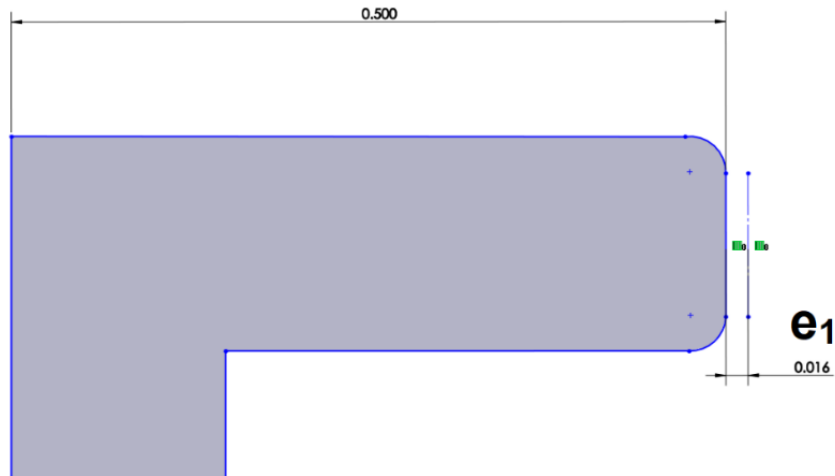
**Figure 3.7** Profile leg having length  $L$ .

Source: New Jersey Precision Technologies

### 3.2.3.1 Leg Length Greater Than 3/8 Inches

If the length of the leg is greater than 3/8 inches the following steps will be done to design extensions and flares for the leg.

1. Select the tips of the legs of the profile and extend it outwards as seen in Figure 3.8, with a customer specified length or using the default value  $e_1$  listed in Table 3.4.



**Figure 3.8** Profile leg extended by  $e_1$  inches for leg length greater than 3/8 inches.

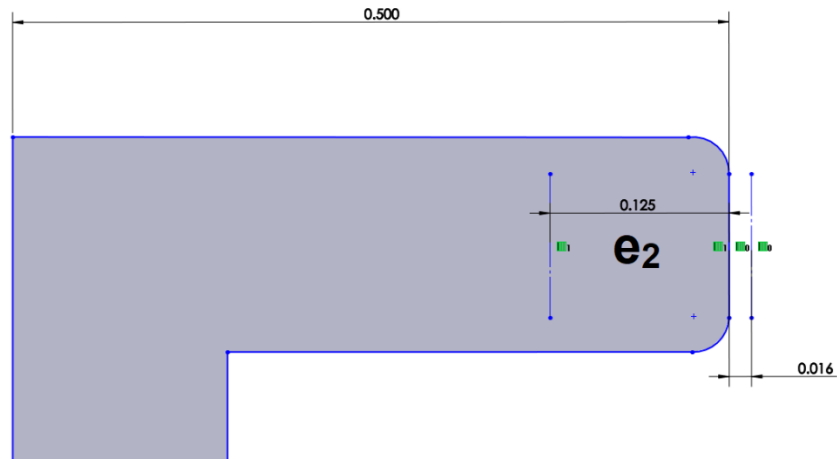
Source: New Jersey Precision Technologies

**Table 3.4** Extension and Offset Values for Leg Modification

Extension Value	Offset (inches)
Outward extension, $e_1$	1/64 or Customer specified
Inward extension, $e_2$	1/8
Side offset, $e_3$	5% of $WT_{die}$

Source: Values based on experiential data from successful design data at New Jersey Precision Technologies.

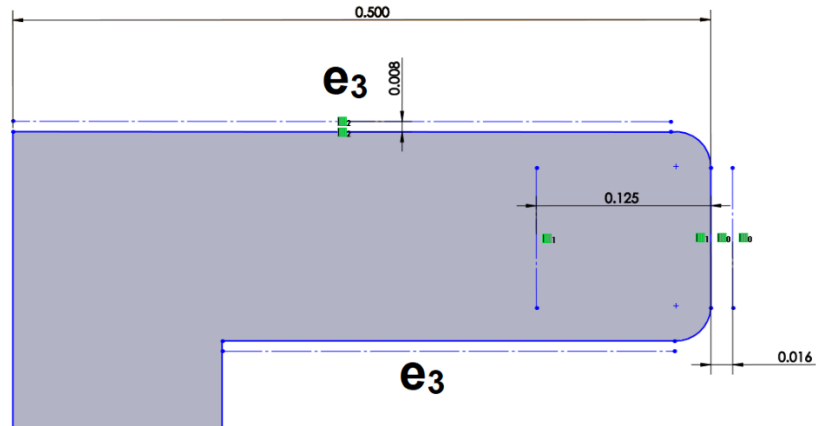
- Offset the end of the leg inwards by  $e_2$  inches, from table 3.4, as shown in Figure 3.9



**Figure 3.9** Offset the leg inwards by an inward extension of  $e_2$  inches for leg length greater than  $3/8$  inches.

Source: New Jersey Precision Technologies

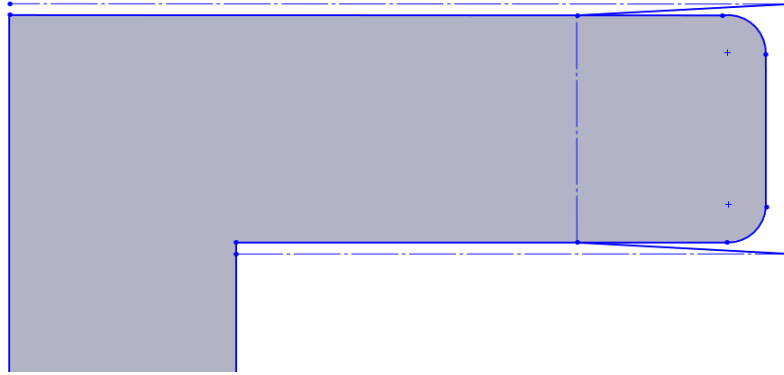
- Offset the sides of the legs to add flares as shown in Figure 3.10. This offset value will be equal to 5% of the wall thickness of the profile.



**Figure 3.10** Offset the sides of the legs by  $e_3$  inches to add flares for leg length greater than  $3/8$  inches.

Source: New Jersey Precision Technologies

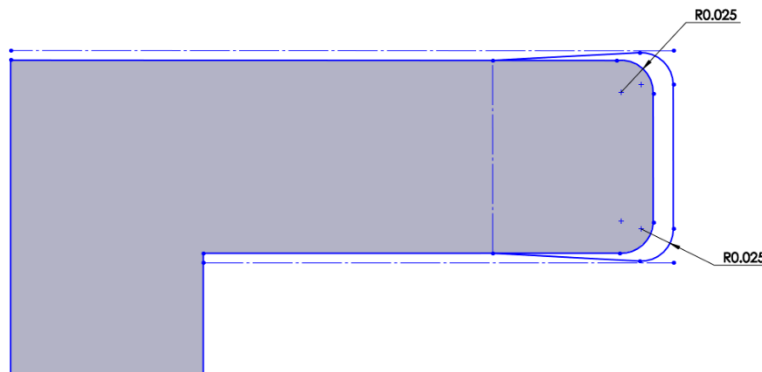
- Join the points of intersection between the point created by intersecting the flares and the leg extension and the point created by intersecting the inward offset of the leg with the sides of the leg as shown in Figure 3.11.



**Figure 3.11** Join the points of intersection between the flares, extension and the inward offset for leg length greater than 3/8 inches.

Source: New Jersey Precision Technologies

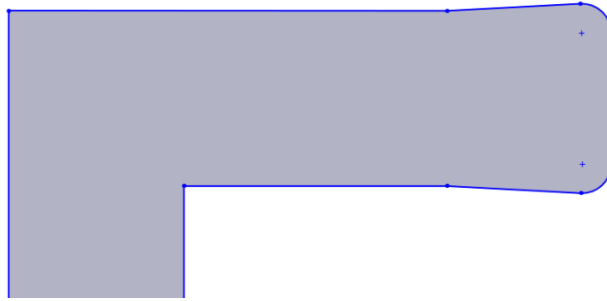
- Assign the same radii of the legs to the created leg extension profile as shown in Figure 3.12. In case the original profile had sharp corners, leave it as it is.



**Figure 3.12** Assign the same radii of the initial profile to the leg extension profile for leg length greater than 3/8 inches.

Source: New Jersey Precision Technologies

- Trim all the unwanted lines to obtain the final profile of the leg as seen in Figure 3.13 with leg extensions and flares added.



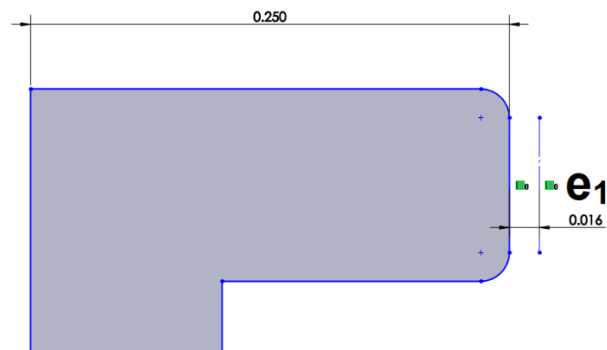
**Figure 3.13** Profile with its leg extended and flares added for leg length greater than 3/8 inches.

Source: New Jersey Precision Technologies

### 3.2.3.2 Leg Length Lesser Than 3/8 Inches

If the length of the leg is less than 3/8 inches the following steps will be done to design extensions and flares for the leg.

- Select the tips of the legs of the profile and extend it outwards as seen in Figure 3.14 with a customer specified length or using the default value  $e_1$  listed in Table 3.4.

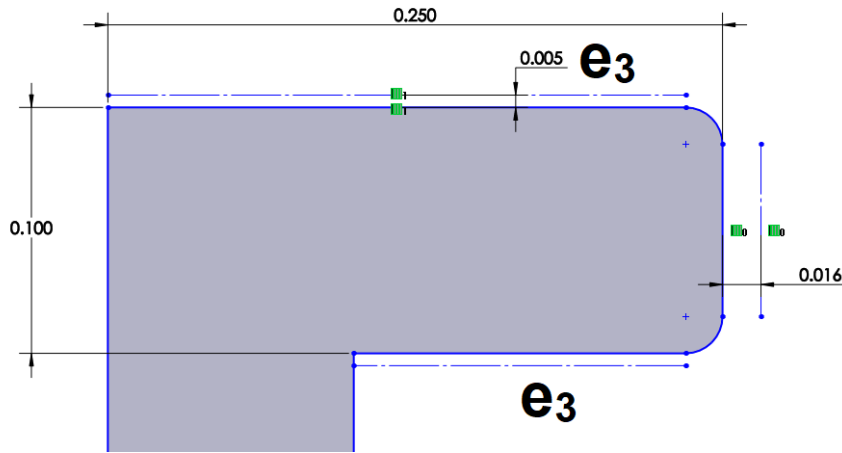


**Figure 3.14** Extend the tip of the leg by  $e_1$  inches for leg length less than 3/8 inches.

Source: New Jersey Precision Technologies



- Offset the sides of the legs to add flares as seen in Figure 3.15. This offset value will be equal to 5% of the wall thickness of the profile.



**Figure 3.15** Offset the sides of the legs by  $e_3$  inches to add flares for leg length less than  $3/8$  inches.

Source: New Jersey Precision Technologies

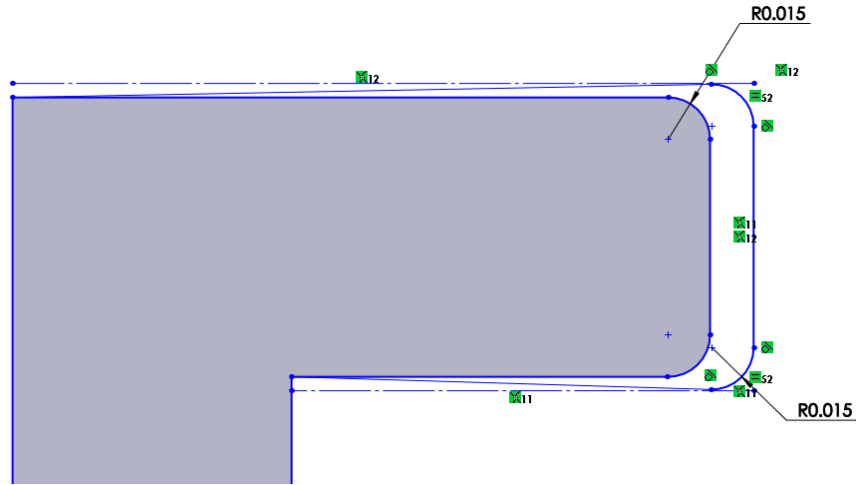
- Join the points of intersection between the point created by intersecting the flares and the leg extension and the starting points of the leg as shown in Figure 3.16.



**Figure 3.16** Join starting points of the leg with points of intersection between flares and extension for leg length less than  $3/8$  inches.

Source: New Jersey Precision Technologies

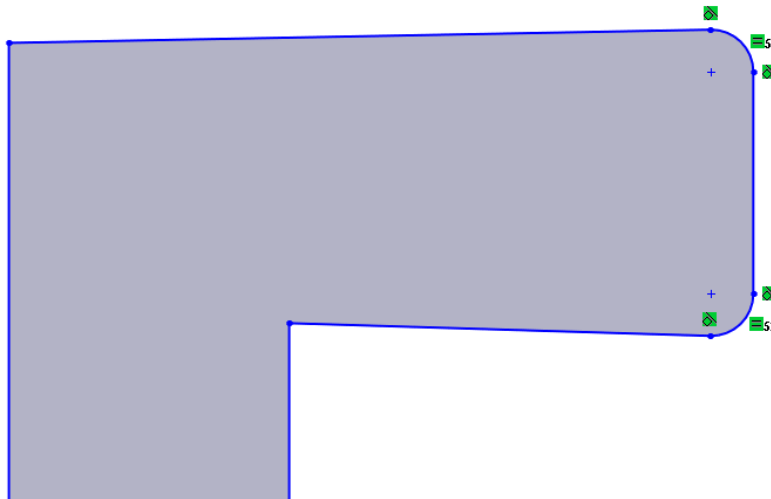
- Assign the same radii of the legs to the created leg extension profile as shown in Figure 3.17. In case the original profile had sharp corners, leave it as it is.



**Figure 3.17** Add the same radius of the initial leg profile onto the leg extension profile for leg length less than 3/8 inches.

Source: New Jersey Precision Technologies

- Trim all the unwanted lines to obtain the final profile with leg extensions and flares added as shown in Figure 3.18.

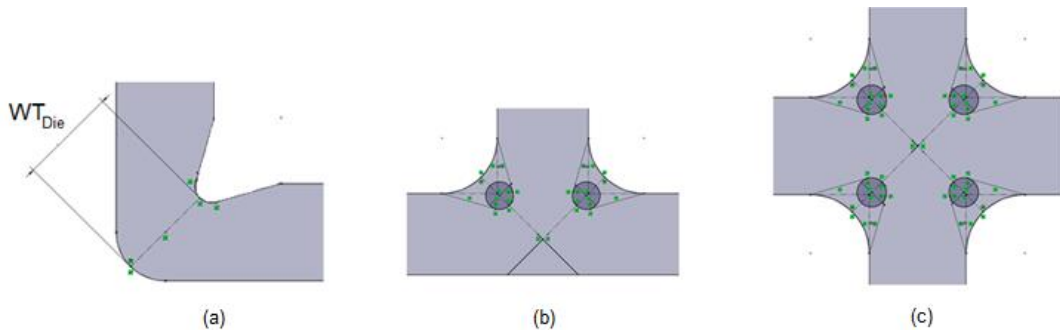


**Figure 3.18** Trim all the construction lines to obtain the leg extension profile for leg length less than 3/8 inches.

Source: New Jersey Precision Technologies

### 3.2.4 Flow Restrictors

Flow restrictors are usually introduced at the joints of the profile (L-shape, T-shape). Usually joints have larger wall thickness, hence the purpose of the flow restrictor is to adjust the wall thickness at the joints to be the same as other places. As seen in Figure 3.19, different types of joints can have a single or multiple flow restrictors depending on requirement.

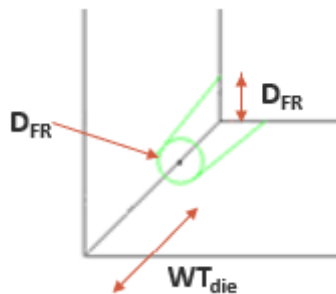


**Figure 3.19** (a) L-Joint with a single flow restrictor, (b) T-Joint with two restrictors, (c) Cross-Joint with four restrictors.

Source: New Jersey Precision Technologies

The diameter of the flow restrictor,  $D_{FR}$  can be calculated as,

$$D_{FR} = 1/3 \times WT_{Die} \quad (3.3)$$

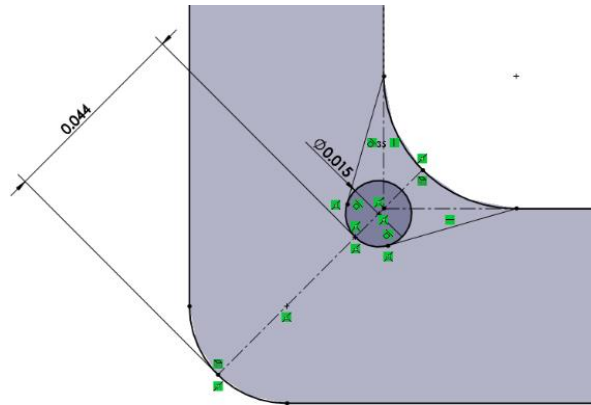


**Figure 3.20** Dimensions of a flow restrictor found at the joints of an extrusion profile.

Source: New Jersey Precision Technologies

To design flow restrictors at the joints of the profile, the following steps are performed,

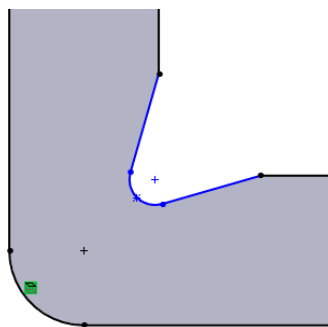
1. Create the following profile of a flow restrictor. Keep in mind the dimensions, the flow restrictor will be placed in such a way that the gap between the corner and the restrictor will be the same as the wall thickness as shown in Figure 3.21.



**Figure 3.21** Positioning the flow restrictor along the joint of an extrusion profile.

Source: New Jersey Precision Technologies

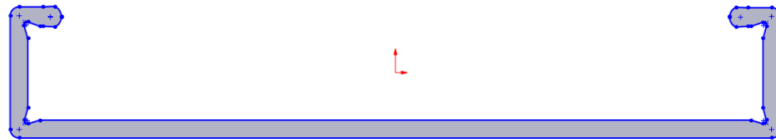
2. Trim the lines as shown in Figure 3.22 to get the inlet profile of the die plate. Repeat the same procedure on the all the other corners of the profile.



**Figure 3.22** Trim lines to obtain the flow restrictor profile.

Source: New Jersey Precision Technologies

Once the flow restrictors have been added at all the joints, it should look like the profile represented in Figure 3.23. This profile becomes the inlet profile of the die plate and the distance between the inlet and the outlet profile will be equal to 10 times the wall thickness of the outlet profile on the die plate. This profile will be assigned to Layer 51 and its line color will be red.

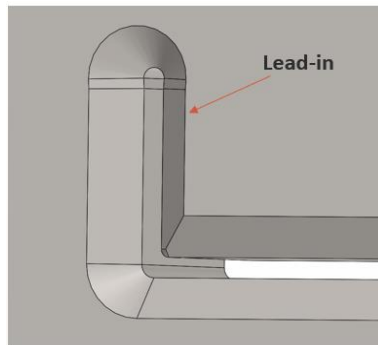


**Figure 3.23** Inlet profile of the die plate with flow restrictors.

Source: New Jersey Precision Technologies

### 3.2.5 Lead-In and Toolpath

Lead-in is a feature that is found only at the inlet of the die plate as shown in Figure 3.24. It is used to improve the flow of the polymer from the transition plate into the final profile of the die plate. There are mainly two kinds of lead-in that is selected depending on customer preference; Ball lead-in and Chamfer lead-in.



**Figure 3.24** Inlet of an extrusion die plate showing the lead-in.

Source: New Jersey Precision Technologies

In the case for chamfer lead-in, we offset the profile with the value denoted as  $L_{offset}$  and can be calculated using the following formula,

$$L_{offset} = 1.25 \times WT_{die} \quad (3.4)$$

Generally, a 45-degree chamfer lead-in is created. Therefore, we can calculate the depth of the lead-in,  $d_L$

$$d_L = \frac{L_{offset}/2}{\tan(90 - \theta)} \quad (3.5)$$

Where,

$\theta$  = Degree of the chamfer tool

In the case of ball lead-in, we again determine the value of  $L_{offset}$  using the same formula however, additionally we use the value of  $L_{offset}$  to calculate the total thickness of the die profile which will be the sum of  $L_{offset}$  and adjusted wall thickness of the die profile. This total thickness is rounded to the nearest available ball end mill diameter ( $D_B$ ), common ball end mill diameters can be found in Table 3.5. The depth ( $d_L$ ) for ball lead-in can be calculated using the following formula,

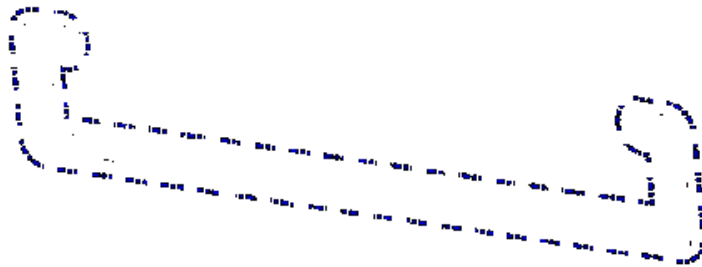
$$d_L = \frac{D_B}{2} \quad (3.6)$$

**Table 3.5** Nominal Diameters for Ball End Mill Tool

Fraction	Inches
1/16	0.0625
1/8	0.1250
3/16	0.1875
1/4	0.2500
3/8	0.3750

Source: New Jersey Precision Technologies

Once we have determined the values for the offset,  $L_{\text{offset}}$  and depth of lead-in,  $d_L$ , we can offset the profile to create the lead-in profile as seen in Figure 3.25. This profile will be represented in dashed lines and will be assigned to Layer 0 with its line color as green. The distance of the lead-in profile from the flow restrictor profile will be same as the value of depth of lead-in,  $d_L$ .



**Figure 3.25** Lead-in profile represented in dashed lines.

Source: New Jersey Precision Technologies

If the type of lead-in selected is ball lead-in, a toolpath has to be added to the profile to represent the path that the ball end mill will assume for manufacturing the lead-in feature at the inlet of the die plate. This is achieved by offsetting the profile such that the toolpath



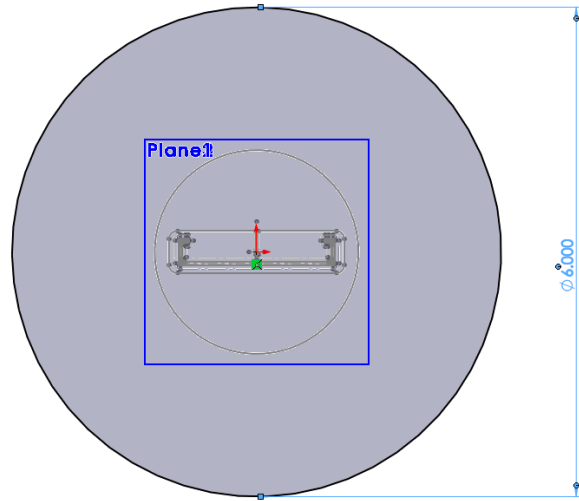


1. Customer requires holes on the die plate but no holes on the transition or the adapter plates: Design counterbore and clearance holes on the die plate following the standard hole pattern or the customer supplied hole pattern.
2. Customer requires holes on the die and the transition plates but not on the adapter plate: Create counterbore and clearance holes on the die plate following the standard hole pattern or the customer supplied hole pattern. Make drill and tap holes on the transition plate such that it aligns with the counterbore and clearance holes on the die plate.
3. Customer requires holes on the Die and Adapter plates but not on the Transition plate: Create the counterbore and clearance holes on the die plate following the standard hole pattern or the customer supplied hole pattern. Create drill and tap holes on the adapter plate in such a way that it will not intersect the holes on the die plate (Usually placed between the counterbore and clearance holes of the die plate).
4. Customer requires holes on the Die, the Transition and the Adapter plates: Design counterbore and clearance holes on the die plate following the standard hole pattern or the customer supplied hole pattern. Drill and Tap holes will be created on the transition plate such that they will be aligned with the holes on the die plate. Counterbore and clearance holes will be designed on the transition plate such that they don't intersect the drill and tap holes on the same plate (Usually placed between the drill and tap holes). Finally drill and tap holes will be designed on the adapter plate such that they will be aligned with the counterbore and clearance holes on the transition plate.

### **3.2.6.1 Round Blank**

If the customer has decided that the die plate will be a round blank, the following steps will be taken to design the blank geometry and its corresponding screw and dowel holes.

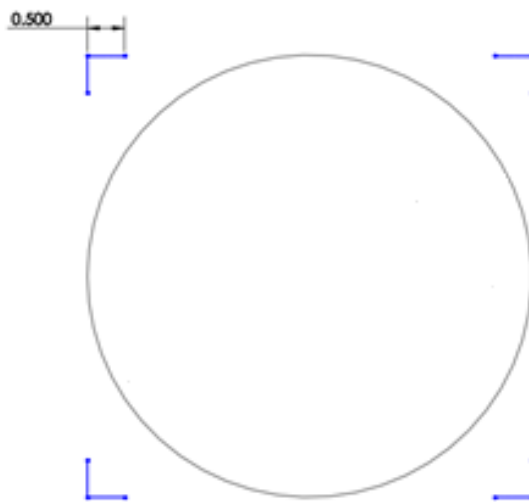
1. Create the chosen geometry of the blank with its center located at the true center of the profile as shown in Figure 3.27. The blank geometry profile will be assigned to layer 31 and will have white as its line color.



**Figure 3.27** Round blank for the die plate.

Source: New Jersey Precision Technologies

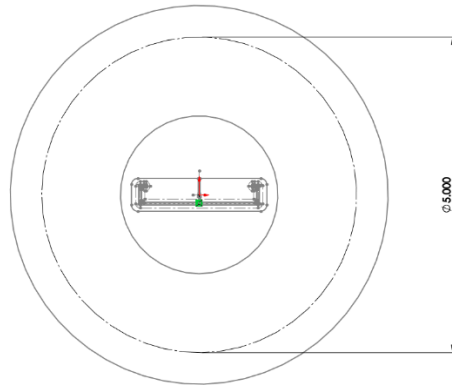
2. Add boundary lines to the die plate at the corners as shown in Figure 3.28. This is only done for round blanks since it is a requirement for NJPT internal manufacturing software. The length of each line will be 0.5 inches and they act as the opposite corners of a square in which the round blank of given diameter can be inscribed. This is also assigned to layer 31 and will have white as its line color.



**Figure 3.28** Adding boundary lines at the corners of the die plate.

Source: New Jersey Precision Technologies

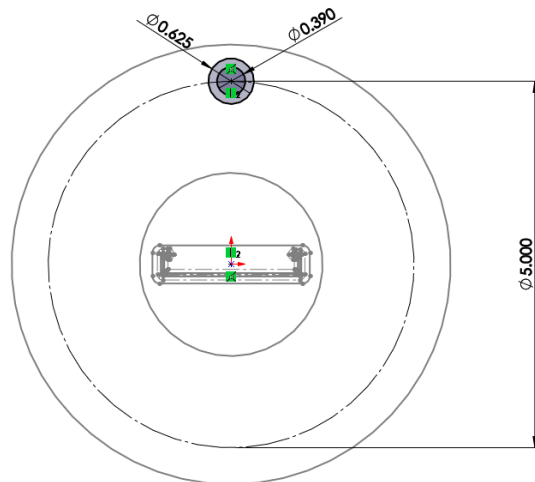
- To add the holes on the plate, we have to create a bolt center of diameter 1 inch less than blank diameter as seen in Figure 3.29.



**Figure 3.29** Bolt center of the die plate for placing holes.

Source: New Jersey Precision Technologies

- Draw a circle depicting the counterbore and clearance hole as shown in Figure 2.31(a) with appropriate dimensions as shown in Table 2.2. By default, we use a 3/8-16 socket head clearance screw. The location of the hole will either follow a standard format as shown below in Figure 3.30 or will use a pattern provided by the customer. The holes will be assigned to layer 20 and will have blue line color in the drawing sheet.



**Figure 3.30** Placing the first hole on a round die plate.

Source: New Jersey Precision Technologies



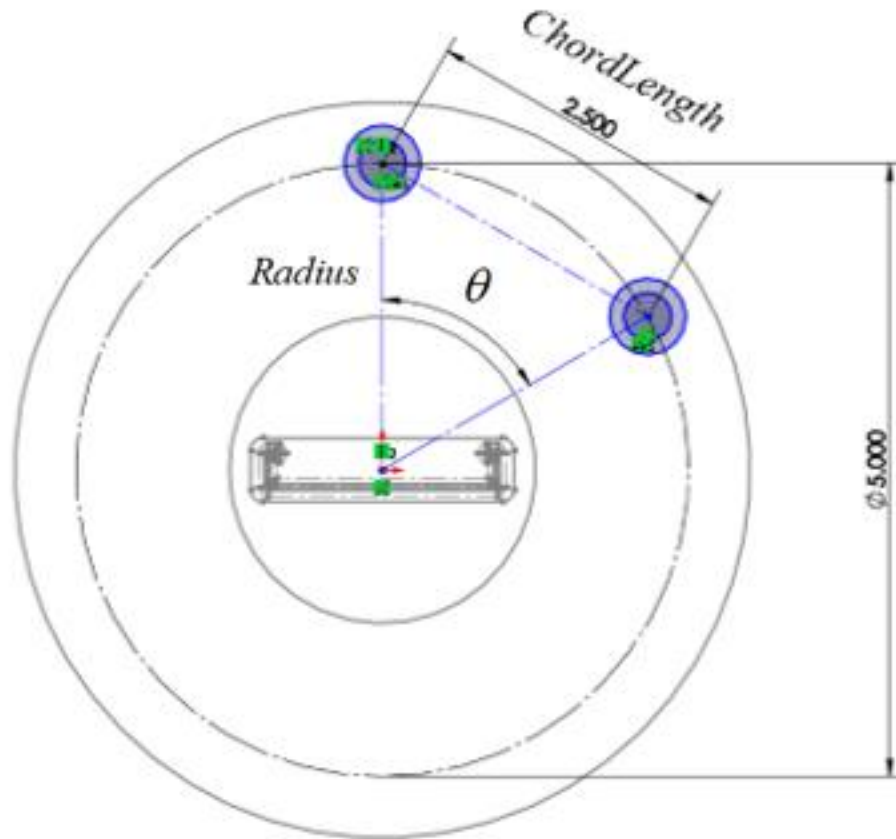
**Figure 3.31** (a) Counterbore and Clearance hole pattern, (b) Drill and Tap hole pattern.

Source: New Jersey Precision Technologies

5. The number of holes will be determined based on the constraint that the chord length between two consecutive holes should be around or close to 2.5 inches as seen in Figure 3.32. The reason being, to prevent any leakage of extrudate between the plates. We can determine the number of holes using the following approach and in case the calculated value is not a whole number, we round it to the nearest integer. The angle  $\theta$  can be found by,

$$\theta = 2 \times \text{Sin}^{-1} \left( \frac{\text{ChordLength}}{2 \times \text{Radius}} \right) \quad (3.7)$$

$$\text{Number of holes} = \frac{360}{\theta} \quad (3.8)$$



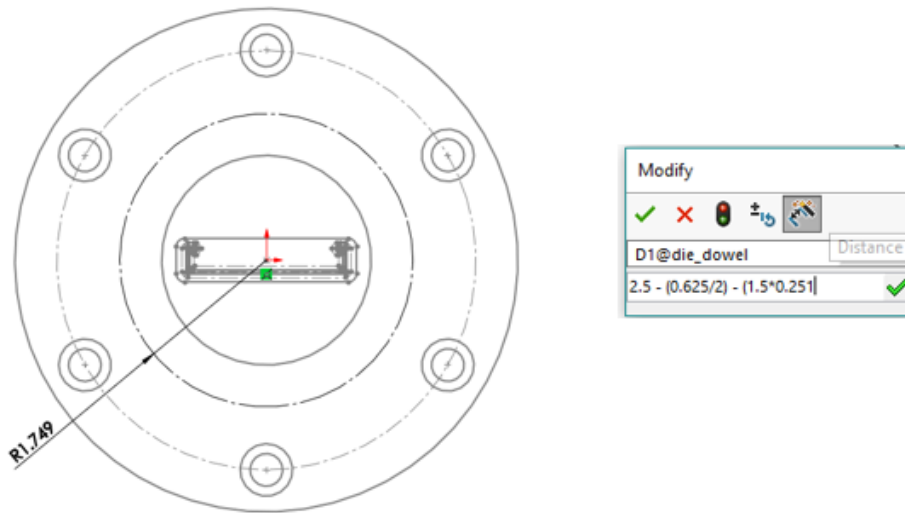
**Figure 3.32** Identifying the number of holes required in a die plate.

Source: New Jersey Precision Technologies

6. The dowel hole placement for round plates will depend on the following constraints:
  - The dowel holes must be at a minimum safe distance of 1.5 times the dowel diameter from the counterbore holes.
  - The dowel holes have to be placed parallel to the longest edge of the product profile.
  - The holes should not intersect the breaker plate located on the back of the adapter plate should be placed at least 0.25in away from the adapter inlet profile.

We can select the dowel diameter from Table 2.3 and to satisfy these conditions we first draw a circle as seen in Figure 3.33, with diameter calculated using the following formula,

$$\frac{\text{Bolt center diameter} - \text{Counterbore hole diameter}}{2} - (1.5 \times \text{Dowel diameter}) \quad (3.9)$$

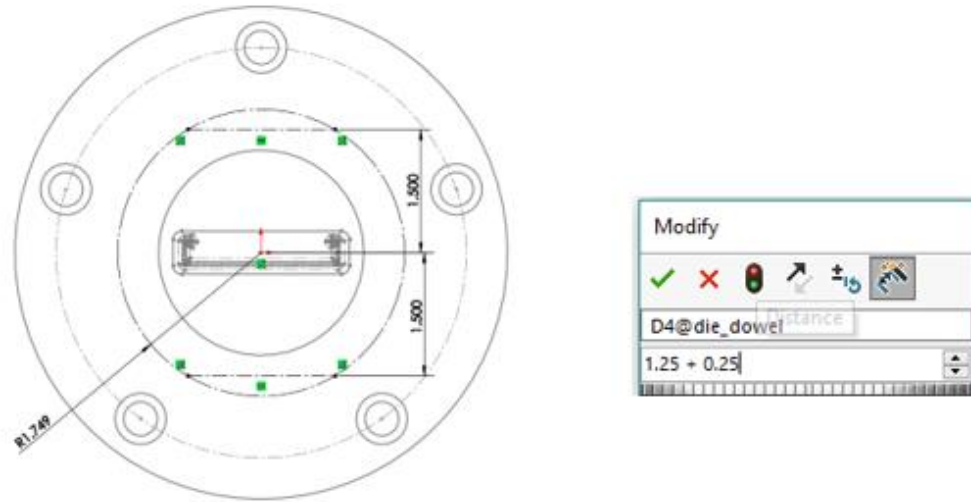


**Figure 3.33** Positioning the first constraint for dowel holes.

Source: New Jersey Precision Technologies

Next we create two opposite lines passing parallel to the longest edge of the profile and keep it at a calculated distance from the center of the die plate as shown in Figure 3.34. This distance is determined using the following formula. The value of breaker clearance is 0.25 inches.

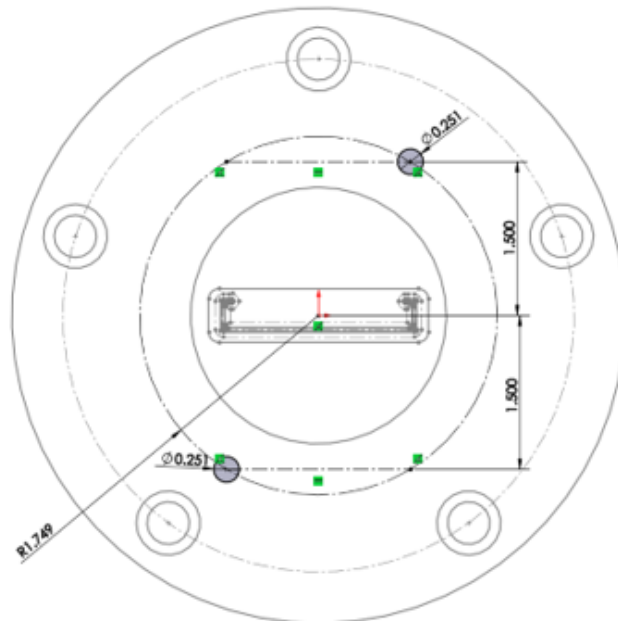
$$\text{Dowel vertical distance} = \text{Extruder output radius} + \text{Breaker clearance} \quad (3.10)$$



**Figure 3.34** Extruder output and breaker clearance condition for dowel placement.

Source: New Jersey Precision Technologies

Finally place the dowel holes at the points of intersection between the created circle and the line. These two positions will be the safest location for the dowel holes.



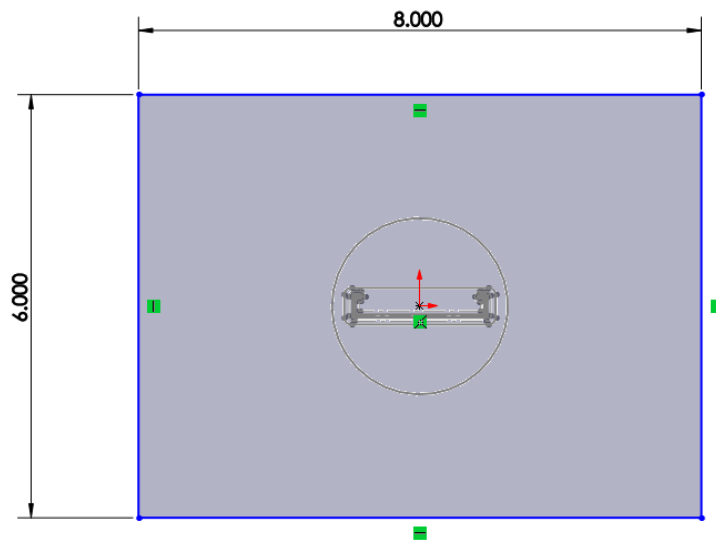
**Figure 3.35** Placing dowel holes at the calculated locations.

Source: New Jersey Precision Technologies

### 3.2.6.2 Rectangular Blank

If the customer has decided that the die plate will be a rectangular blank, the following steps will be taken to design the blank geometry and its corresponding screw and dowel holes.

1. Create the chosen geometry with its center located at the true center of the profile as seen in Figure 3.36. This geometry will be assigned to layer 31 and have a white line color in the drawing sheet.

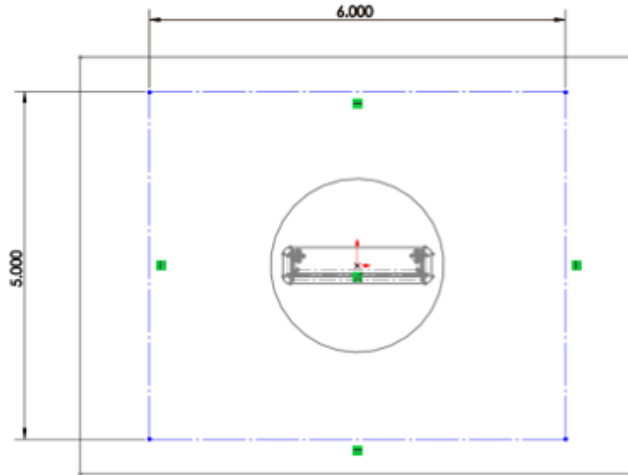


**Figure 3.36** Rectangular blank for the die plate.

Source: New Jersey Precision Technologies

2. To add the holes on the plate, we have to create an offset of the sides similar to the bolt center in the case of a round plate. The dimensions of the offset rectangle will be  $(\text{length of plate} - 2) \times (\text{height of plate} - 1)$  as seen in Figure 3.37. The screw holes will be placed on this offset rectangle.

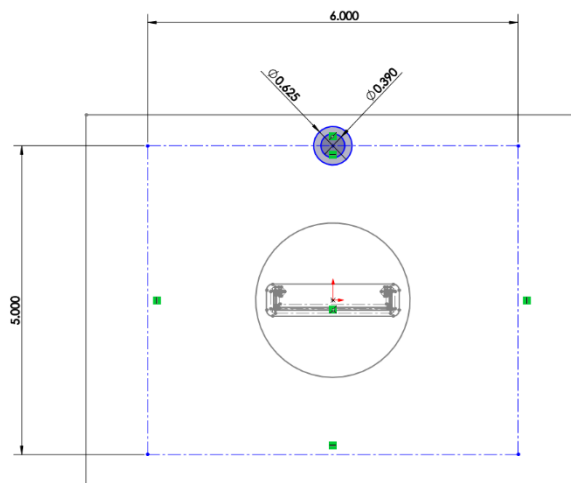




**Figure 3.37** Bolt positioning offset for rectangular die plate.

Source: New Jersey Precision Technologies

3. Draw a circle depicting the counterbore and clearance hole as shown in Fig 3.31(a) with appropriate dimensions as shown in Table 2.2. By default, we use a 3/8-16 socket head clearance screw. The location of the hole will either follow a standard format as shown below or will use a pattern provided by the customer. The hole will be assigned to layer 20 and will have a blue line color in the drawing sheet.



**Figure 3.38** Counterbore and clearance hole on a rectangular die plate.

Source: New Jersey Precision Technologies

4. The number of holes will be determined based on the constraint that the length between two consecutive holes should be around or close to 2.5 inches as seen in Figure 3.39. The reason being, to prevent any leakage of extrudate between the plates. We can determine the number of holes on each side of the profile using the following approach,

$$\text{Number of segments} = \frac{\text{Length of offset}}{2.5} \quad (3.11)$$

$$\text{No. of holes} = \text{No. of segments} + 1 \quad (3.12)$$

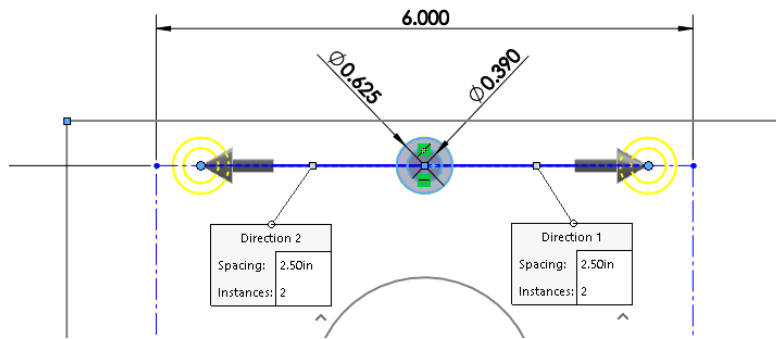
In this case,

$$\text{Number of segments} = 6/2.5 = 2.4$$

We round it to the closest integer which is 2.

Each segment will have a hole on each side.

$$\text{No. of holes} = 3 \text{ holes}$$



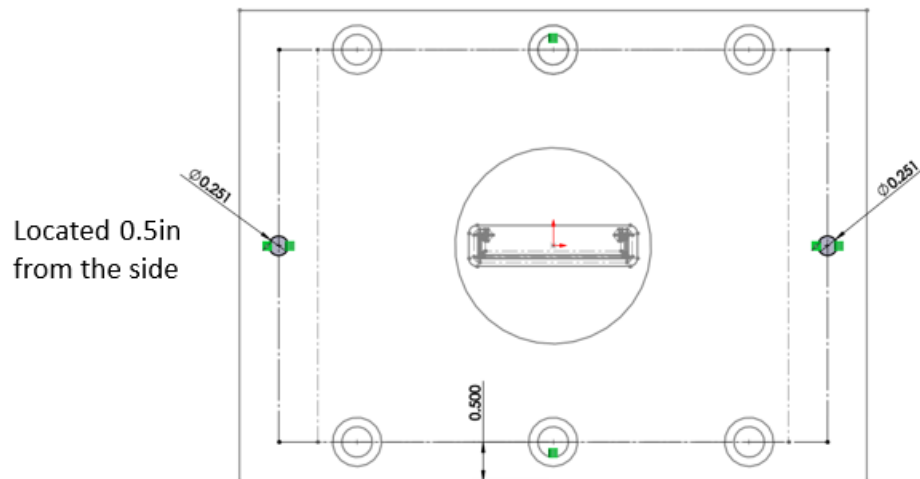
**Figure 3.39** Identifying the number of holes required in a rectangular die.

Source: New Jersey Precision Technologies

This process is repeated on each side of the plate to determine the total number of holes for the rectangular blank.

5. The positioning of the slip fit dowel hole for rectangular plates will be placed in such a way that,
- It will be 0.5in from the sides of the rectangular plate.
  - The dowel holes are placed in such a way that it lies on the line going through center of the plate.
  - Lies on the point of intersection between the line going through the center of the plate and the 0.5 in offset line

The dowel holes will also be assigned to layer 20 and will have blue line color in the drawing sheets.



**Figure 3.40** Dowel hole placement for rectangular plate.

Source: New Jersey Precision Technologies

This concludes all the steps required to successfully design an extrusion die plate which can be used to extrude the selected product profile geometry.

### 3.3 Design Protocol for Adapter Plate

Adapter plate also known as feed head is the first plate that is attached to the extruder machine and it servers the role of accepting the polymer and supporting its flow into the extrusion die assembly.

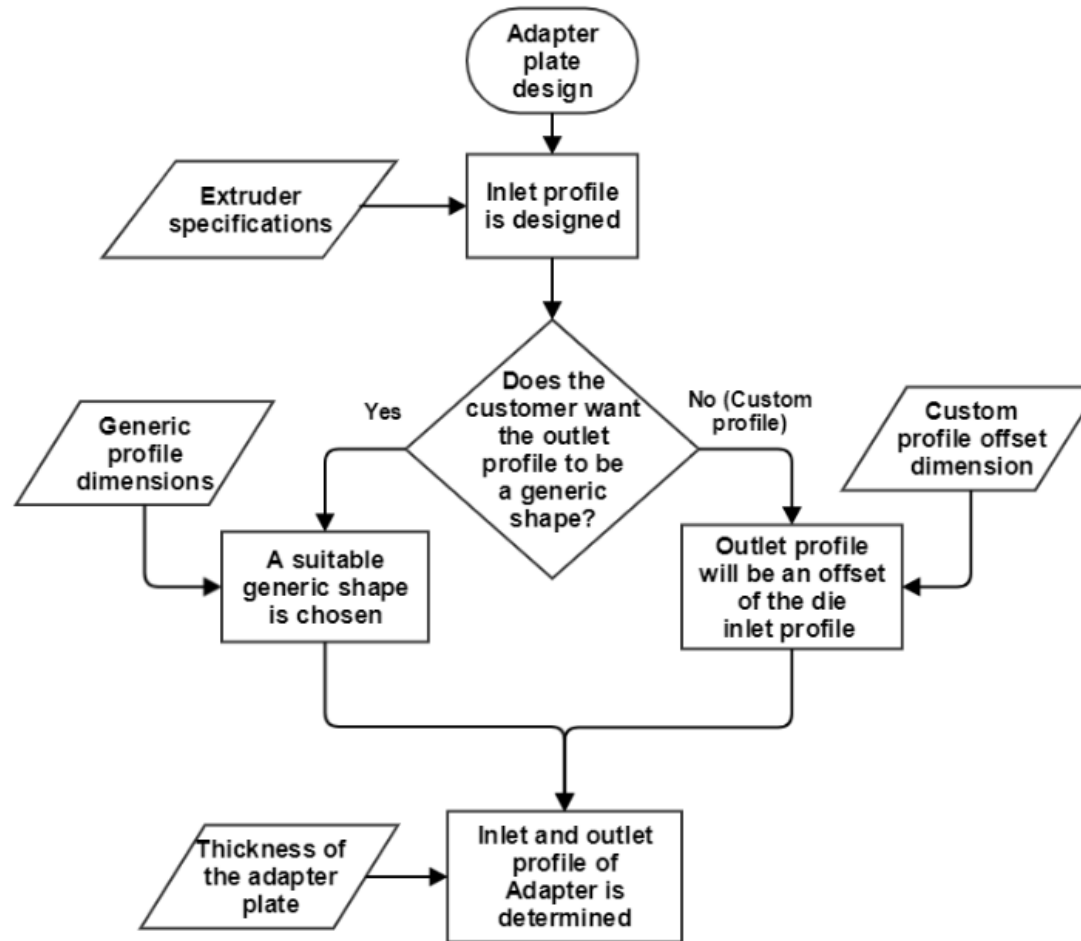
#### 3.3.1 Overall Workflow for Design of Adapter Plate

The design of an adapter plate as seen in Figure 3.42, begins with the designing the inlet profile of the plate using extruder specifications. Next based on customer preference the outlet profile will either be a generic shape or a custom offset of the inlet profile found on the die plate. Finally, the thickness of the plate is calculated and screw holes and dowel holes are added.



**Figure 3.41** Adapter plate is the highlighted plate in the extrusion tooling assembly.

Source: New Jersey Precision Technologies

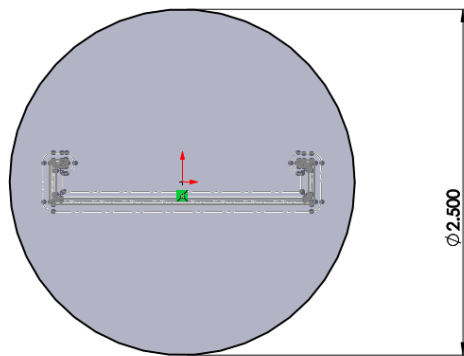


**Figure 3.42** Overall design workflow involved in designing an adapter plate.

Source: New Jersey Precision Technologies

### 3.3.2 Design of Inlet Profile for Adapter Plate

The inlet profile of the adapter plate will depend on the size of the extruder outlet and is often obtained from the customer. Usually plastic extruders have diameters of 2.5 inches or 3.5 inches. The geometry of the adapter will be a simple circle with the same diameter as the extruder outlet. This profile will be assigned to layer 51 and will have the line color red in the drawing sheet.



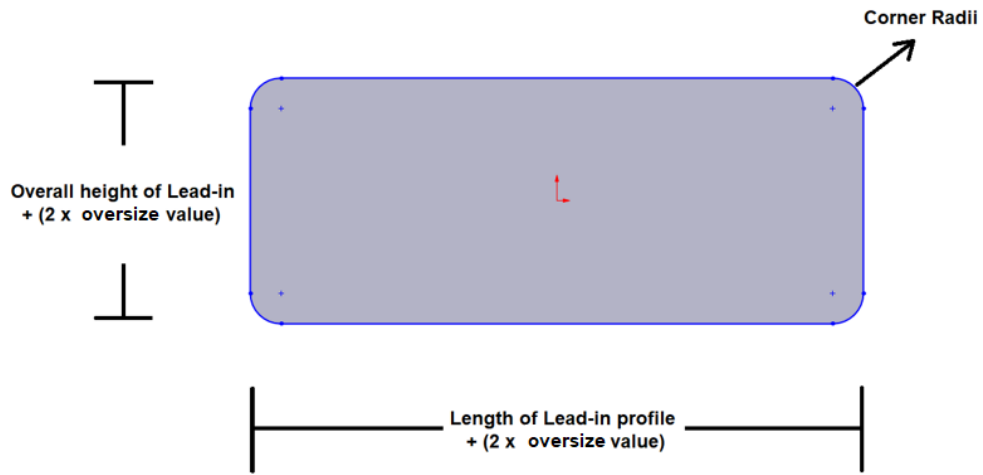
**Figure 3.43** Inlet profile of an adapter plate.

Source: New Jersey Precision Technologies

### 3.3.3 Design of Outlet Profile for Adapter Plate

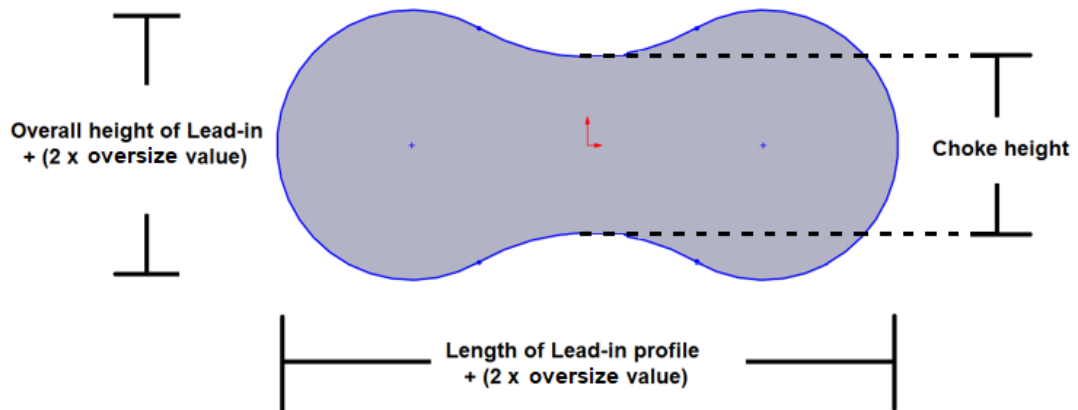
The aim of the outlet profile of the adapter plate is to have a geometry that will provide the most effective flow into the transition plate such that it delivers polymer to all parts of the product profile evenly and in a uniform manner.

It can either be a generic shape like a rectangle, a round and hourglass or it can be a custom shape as an offset of the product profile. The choice completely depends on the customer. The oversize value is assumed to be 0.15 inches and all the dimensions can be varied depending on the work order. The outlet profile will be assigned to layer 50 and will have green line color in the drawing sheet.



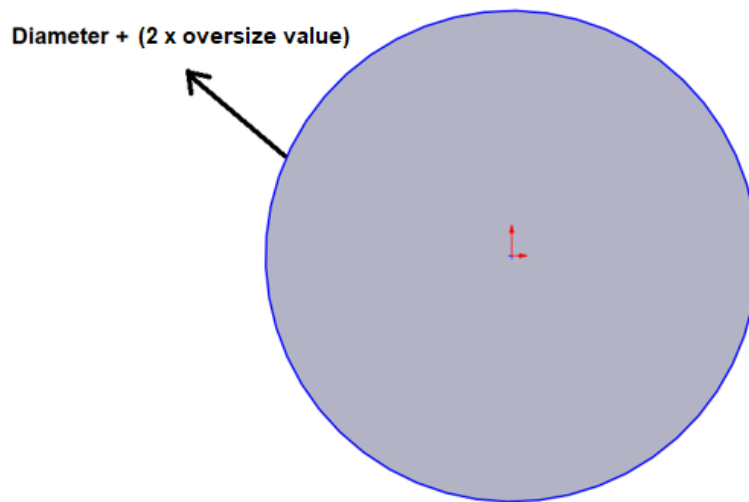
**Figure 3.44** Generic rectangular outlet profile and its dimensions.

Source: New Jersey Precision Technologies



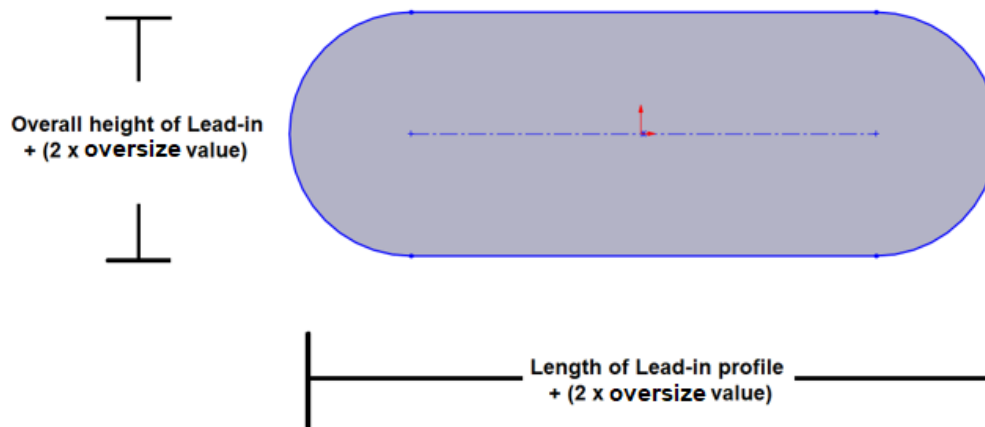
**Figure 3.45** Generic hourglass outlet profile and dimensions.

Source: New Jersey Precision Technologies



**Figure 3.46** Generic round outlet profile and dimensions.

Source: New Jersey Precision Technologies

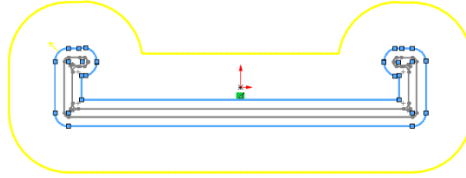


**Figure 3.47** Generic rectangular slot outlet profile and dimensions.

Source: New Jersey Precision Technologies



In the case for a need for a custom profile. The die lead-in profile will be offset outwards by 0.25 inches as shown in Figure 3.48.

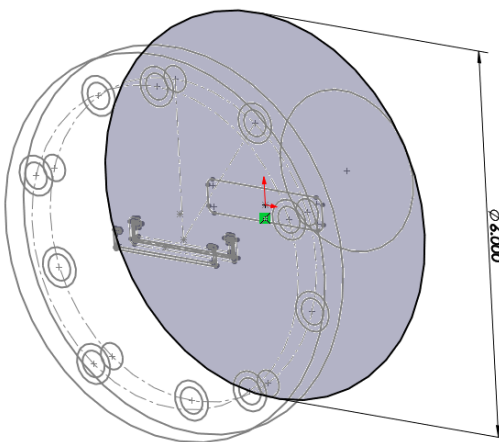


**Figure 3.48** Custom outlet profile of adapter plate.

Source: New Jersey Precision Technologies

### 3.3.4 Creating Blank for Adapter Plate

The blank represents the steel plate on to which the adjusted profile is incorporated into. For an adapter plate the blank can only be of round geometry as seen in Figure 3.49. Hence create a circle with center located at the true center of the profile. The blank diameter will be supplied by customer or by designer. The blank geometry will be assigned to layer 31 and will have white as its line color in the drawing sheets.



**Figure 3.49** Round blank for the adapter plate.

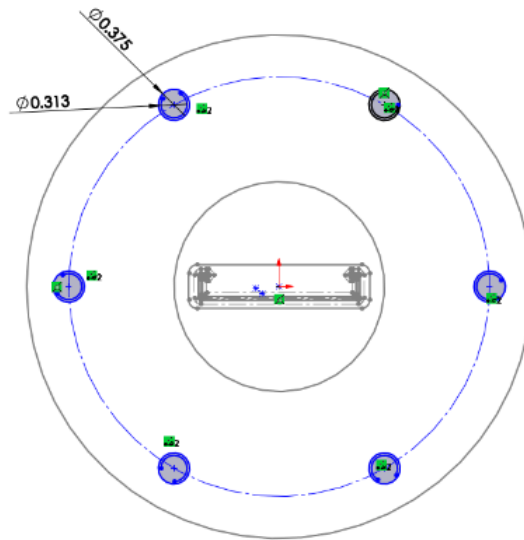
Source: New Jersey Precision Technologies

Add boundary lines to the adapter plate similar to the die plate at the corners as shown in Figure 3.28. This is only done for round blanks since it is a requirement for NJPT internal manufacturing software. The length of each line will be 0.5 inches and they act as the opposite corners of a square in which the round blank of given diameter can be inscribed. This is also assigned to layer 31 and will have white as its line color.

### **3.3.5 Adding Holes for Adapter Plate**

Holes are added on the adapter plate so that it allows the customer to secure the adapter plate with the other plates in the assembly. The adapter plate will always have tapped holes. It is the customer's choice whether to have holes on any plate individually. This decision will impact the requirement to design holes for adapter plate and it can be determined from Table 2.1. The drill and tap holes in the adapter plate will be located on the bolt center which has a diameter of 1 inch less than the blank diameter or will follow a customer specified bolt pattern.

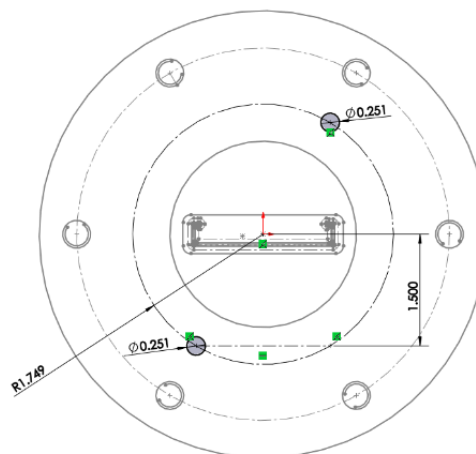
The number of adapter holes are also determined using the same method used to calculate the number of holes for round die plates as seen in Figure 3.32. Draw circles depicting the drill and tap hole as shown in Figure 3.31(b) with appropriate dimensions as shown in Table 2.2. By default, we use drill and tap for 3/8-16 size. The adapter plate holes are assigned to layer 20 and will have blue as the line color in the drawing sheets.



**Figure 3.50** Drill and tap holes on a round adapter plate.

Source: New Jersey Precision Technologies

Dowel hole placement for adapter plate are also follow the same conditions applied for round die plate as seen in Figure 3.33 and Figure 3.34. Using these conditions place slip fit dowel holes at the calculated locations on the adapter plate as seen in Figure 3.51.



**Figure 3.51** Placing dowel holes at the calculated locations on adapter plate.

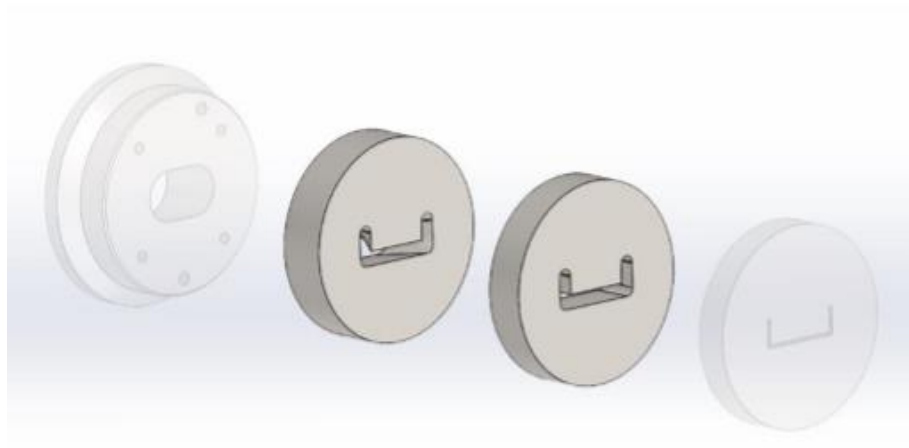
Source: New Jersey Precision Technologies

### 3.4 Design Protocol for Transition Plate

Transition plates form the intermediary channel through which the polymer flows from the adapter into the die plate and can only be designed after designing both the die and the adapter plates.

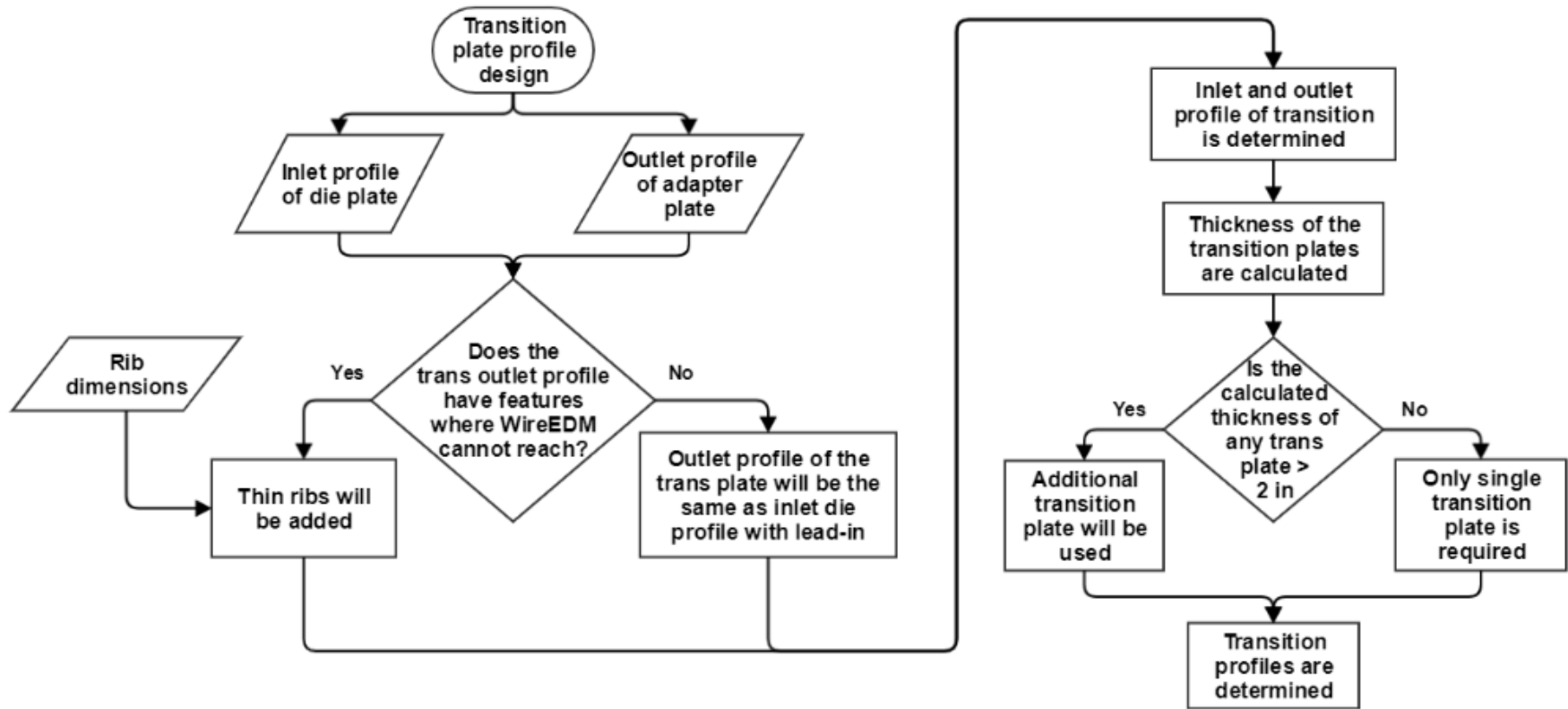
#### 3.4.1 Overall Workflow for Design of Transition Plate

Using the inlet profile of the die plate and the outlet profile of the adapter plate, the designer will determine if there are features that might create problems for the wire in the WireEDM manufacturing process to reach. In such a case, ribs will be added to the inlet profile of the transition plate else, the inlet profile of the transition plate will be the same as the outlet of the adapter plate and the outlet profile of the translate will be the same as the inlet profile of the die plate with the lead-in. Next the thickness of the transition plate is determined and if the thickness is greater than 2 inches, an additional transition plate will be used. Figure 3.53 shows the overall design workflow of creating a transition plate.



**Figure 3.52** Transition plates are the highlighted plates in the extrusion tooling assembly.

Source: New Jersey Precision Technologies

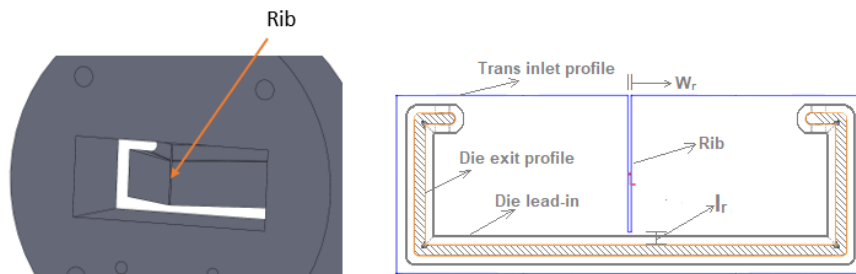


**Figure 3.53** Design workflow showing the steps involved in designing the transition plate.

Source: New Jersey Precision Technologies

### 3.4.2 Design of Inlet Profile for Transition Plate

The inlet profile of the transition plate will be the same as the outlet profile of the adapter plate. However, in cases where the geometry of the product will have areas where the wire of the WireEDM machining process cannot reach, additional ribs as seen in Figure 3.54 will have to be added into the profile. The inlet profile will be assigned to layer 51 and will have red as its line color in the drawing sheet.  $W_r$  stands for width of the rib and  $l_r$  represents the distance between the rib and the die exit profile.

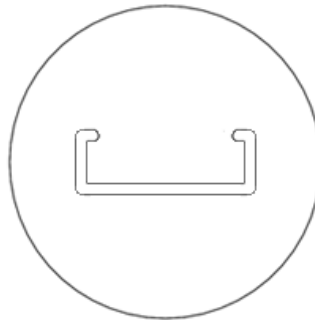


**Figure 3.54** Inlet profile of the transition plate with ribs.

Source: New Jersey Precision Technologies

### 3.4.3 Design of Outlet Profile for Transition Plate

The outlet profile of the transition plate will be the inlet profile of the die plate with lead-in. The outlet of the transition plate will directly attach on to the die plate.

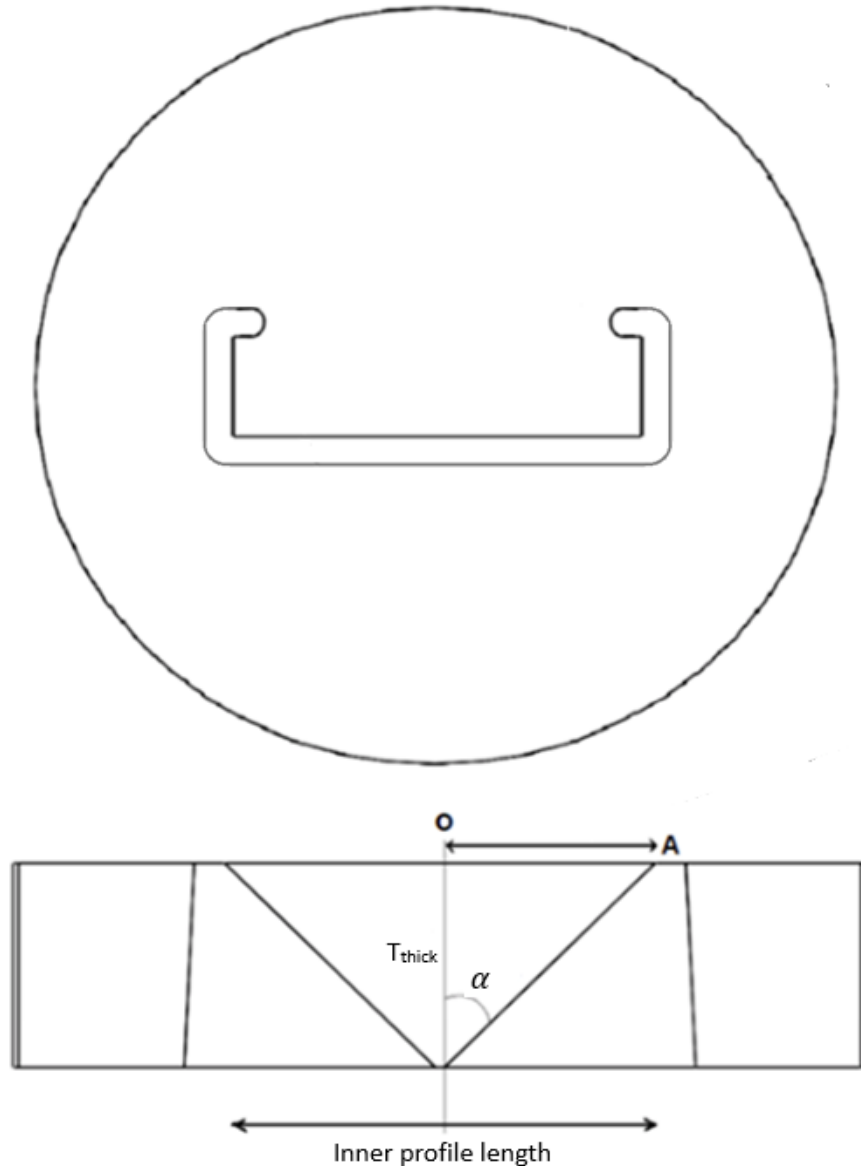


**Figure 3.55** Outlet profile of trans same as inlet of the die plate with lead-in.

Source: New Jersey Precision Technologies

### 3.4.4 Thickness of Transition Plate

The main factor defining the thickness of the transition plate is the wire cutting angle that will be required to manufacture the transition plate. The preferred value of the wire cutting angle  $\alpha = 19$  degrees and it can go up to a maximum of 45 degrees beyond which the wire used for WireEDM machine will undergo failure.



**Figure 3.56** Determining thickness of transition plate.

Source: New Jersey Precision Technologies

From Figure 3.56, we can see that to determine the value of  $T_{thick}$  which represents the thickness of the transition plate, we can use the following formula.

$$T_{thick} = \frac{OA}{\tan(\alpha)} \quad (3.13)$$

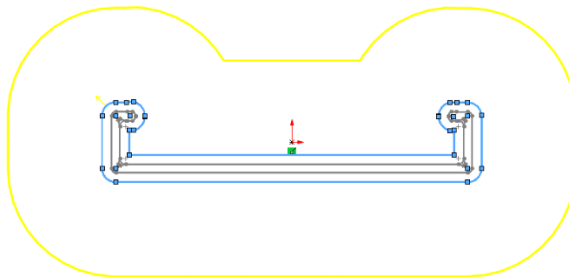
Where,

$$OA = \frac{(\text{Inner profile length} - \text{width of rib})}{2} \quad (3.14)$$

The calculated thickness of the transition plate, if it exceeds 2 inches then there will be a need for an additional transition plate. In case we have to add an additional transition plate,

- The inlet of the first trans plate will be the same as outlet of the adapter with ribs.
- The outlet of the first trans will be the inlet of the second trans plate (inter. profile).
- The outlet of the second trans plate will be the inlet of the die plate with lead-in.

In case the customer does not require the design of an adapter plate, then the intermediary trans profile as seen in Figure 3.57 will simply be an offset of 0.5 inches per side of the inlet die plate profile with lead-in.

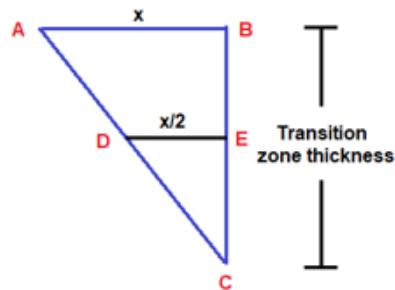
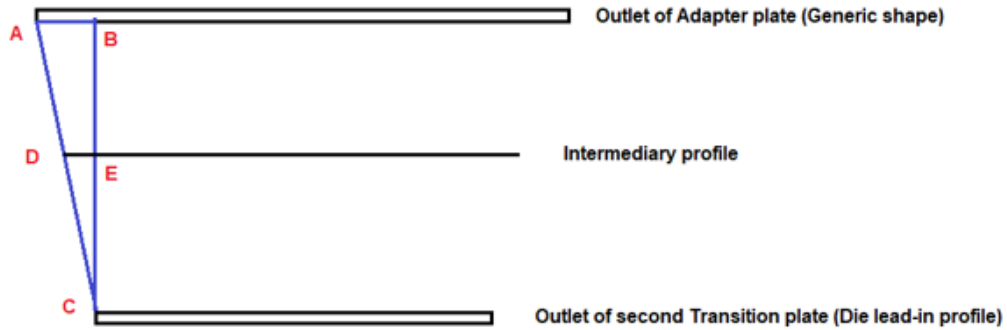


**Figure 3.57** Intermediary profile in the case of multiple transition plates.

Source: New Jersey Precision Technologies



However, if the customer requires an adapter plate then the intermediary profile has to be designed in such a way to determine how much we have to offset the die lead-in profile.



**Figure 3.58** Calculating offset for intermediary transition profile.

Source: New Jersey Precision Technologies

From Figure 2.60, we can say that,

$$BE = EC \text{ (Transition 1 thickness = Transition 2 thickness)} \quad (3.15)$$

$$x = \frac{(\text{Largest dimension of generic shape}) - (\text{Largest dimension of die lead-in profile})}{2} \quad (3.16)$$

The value of  $x/2$  will give the value with which we have to offset to obtain the intermediary transition profile.

### 3.4.5 Adding Blank and Holes

The blank for transition plate can either be round or rectangular and depends on the shape of the blank selected for the die plate.

Holes are added on the transition plate so that it allows the customer to secure the transition plate with the other plates in the assembly. It is the customer's choice whether to have holes on any plate individually. This can be simplified into the following three cases. A summary of the above decisions can be found represented in a tabular format in Table 2.1.

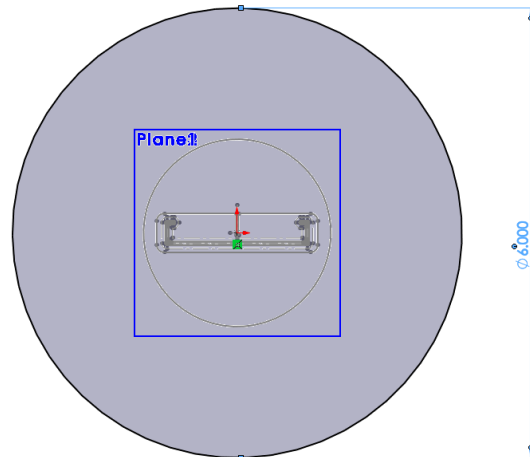
1. Customer requires holes on the Transition plate but no holes on the Die or the Adapter plates: Since we lack the information regarding the holes on the die and the adapter plates, it becomes impossible to create holes on the transition plate unless the customer is willing to provide the necessary information.
2. Customer requires holes on the Transition and the Die plates but not on the Adapter: Create counterbore and clearance holes on the die plate following the standard hole pattern or the customer supplied hole pattern. Make drill and tap holes on the transition plate such that it aligns with the counterbore and clearance holes on the die plate.
3. Customer requires holes on the Transition and Adapter plates but not on the Die plate: In this scenario, create counterbore and clearance holes on the transition plate following the standard hole pattern or the customer supplied hole pattern. The designer will also have to create drill and tap holes on the adapter plate in such a way that it will be aligned with the counterbore and clearance holes on the transition plate.
5. Customer requires holes on the Die, the Transition and the Adapter plates: Design counterbore and clearance holes on the die plate following the standard hole pattern or the customer supplied hole pattern. Drill and Tap holes will be created on the transition plate such that they will be aligned with the holes on the die plate. Counterbore and clearance holes will be designed on the transition plate such that

they don't intersect the drill and tap holes on the same plate (Usually placed between the drill and tap holes). Finally drill and tap holes will be designed on the adapter plate such that they will be aligned with the counterbore and clearance holes on the transition plate.

### 3.4.5.1 Round Blank

If the customer has decided that the transition plate will be a round blank, the following steps will be taken to design the blank geometry and its screw and dowel holes.

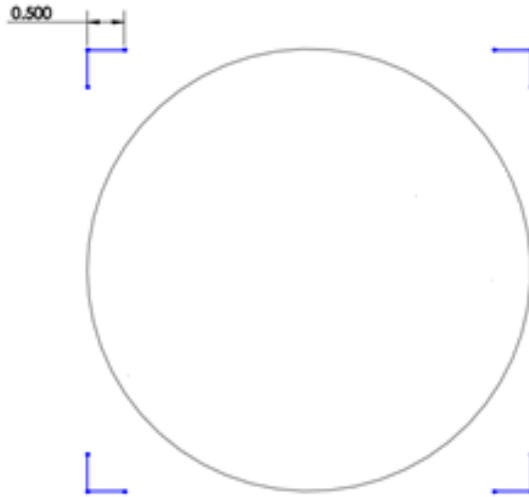
1. Create the blank with its center located at the true center of the profile as shown in Figure 3.59. The blank will be assigned to layer 31 and have white as its line color.



**Figure 3.59** Round blank for the transition plate.

Source: New Jersey Precision Technologies

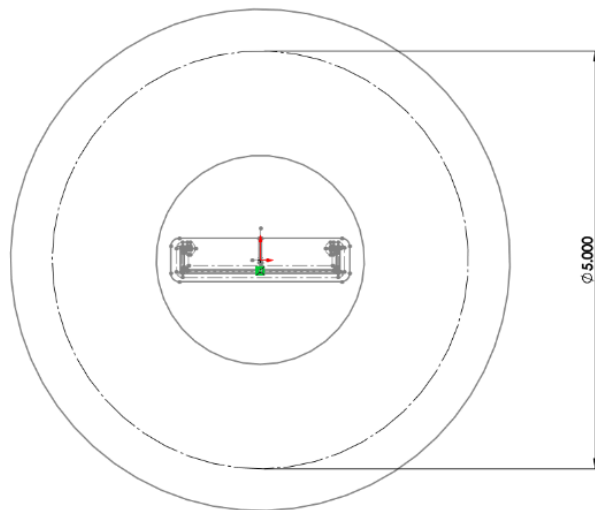
2. Add boundary lines to the plate at the corners as shown in Figure 3.60. This is only done for round blanks since it is a requirement for NJPT internal manufacturing software. The length of each line will be 0.5 inches and they act as the opposite corners of a square in which the round blank of given diameter can be inscribed. This is also assigned to layer 31 and will have white as its line color.



**Figure 3.60** Adding boundary lines at the corners of the transition plate.

Source: New Jersey Precision Technologies

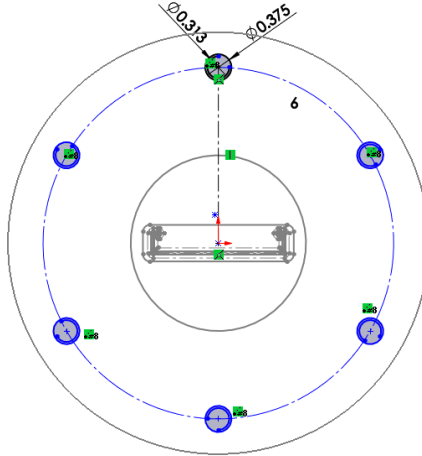
3. To add the holes on the plate, we have to create a bolt center of diameter 1 inch less than blank diameter as seen in Figure 3.61.



**Figure 3.61** Bolt center of the transition plate for placing holes.

Source: New Jersey Precision Technologies

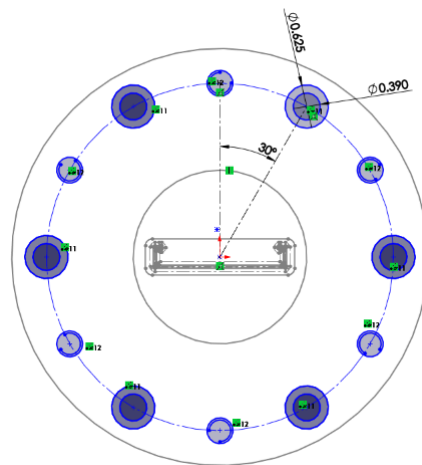
4. Draw a circle depicting the drill and tap hole as shown in Figure 2.31(b) with appropriate dimensions as shown in Table 2.2. By default, we drill and tap using the same screw size, the location of the holes and the number of holes as the counterbore and clearance holes used for the round die plate. The holes will be assigned to layer 20 and will have blue line color in the drawing sheet.



**Figure 3.62** Drill and tap holes on a round transition plate.

Source: New Jersey Precision Technologies

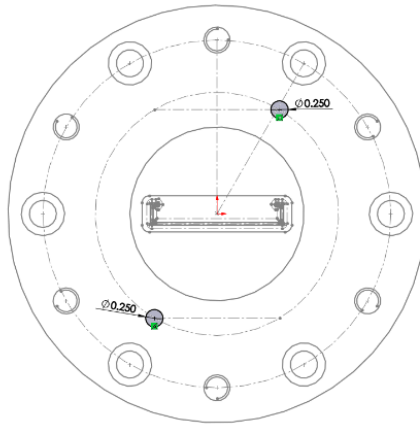
5. Now we add the counterbore and clearance holes to the transition plate at the same locations where there was drill and top holes on the adapter plate.



**Figure 3.63** Counterbore and clearance holes on a round transition plate.

Source: New Jersey Precision Technologies

6. Dowel hole placement for round transition plate are also follow the same conditions applied for round die plate as seen in Figure 3.33 and Figure 3.34. Using these conditions place tap fit dowel holes at the calculated locations on the transition plate as seen in Figure 3.64.

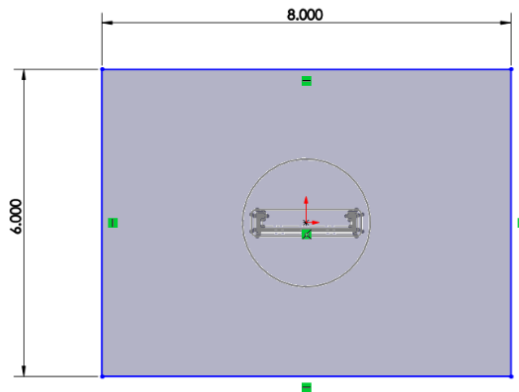


**Figure 3.64** Placing dowel holes at the calculated locations on transition plate.

Source: New Jersey Precision Technologies

### 3.4.5.2 Rectangular Blank

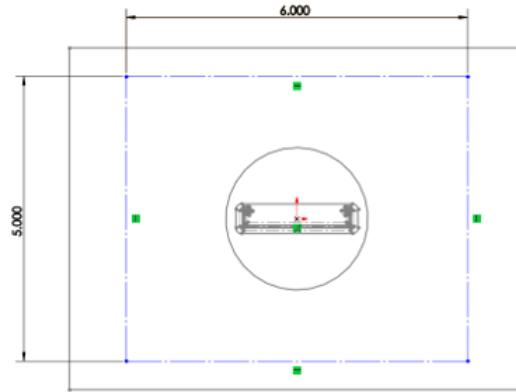
1. Create the blank with its center located at the true center of the profile as seen in Figure 6.65. This geometry will be assigned to layer 31 and have a white line color in the drawing sheet.



**Figure 3.65** Rectangular blank for the transition plate.

Source: New Jersey Precision Technologies

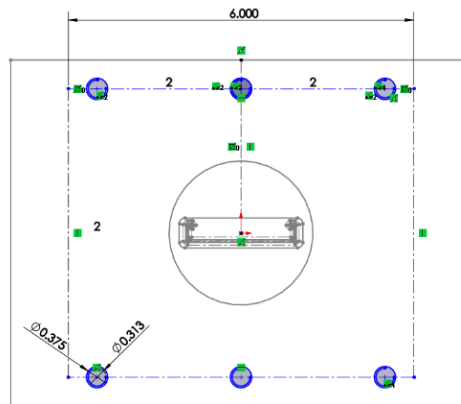
- To add the holes on the plate, we have to create an offset of the sides similar to the bolt center in the case of a round plate. The dimensions of the offset rectangle will be (length of plate - 2) x (height of plate - 1) as seen in Figure 3.66. The screw holes will be placed on this offset rectangle.



**Figure 3.66** Bolt positioning offset for rectangular transition plate.

Source: New Jersey Precision Technologies

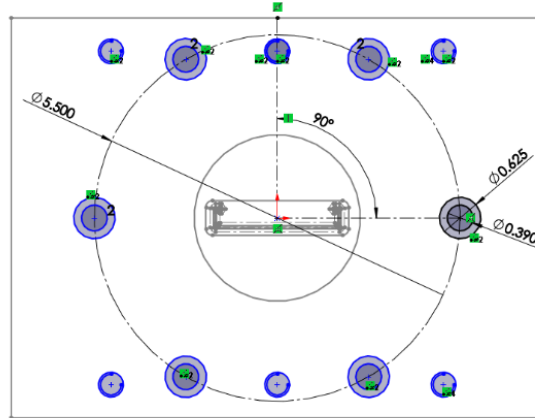
- Draw a circle depicting the drill and tap hole as shown in Fig 2.31(b) with appropriate dimensions as shown in Table 2.2. The location of the holes and the number of holes as the counterbore and clearance holes used for the rectangular die plate.



**Figure 3.67** Drill and tap holes on a rectangular transition plate.

Source: New Jersey Precision Technologies

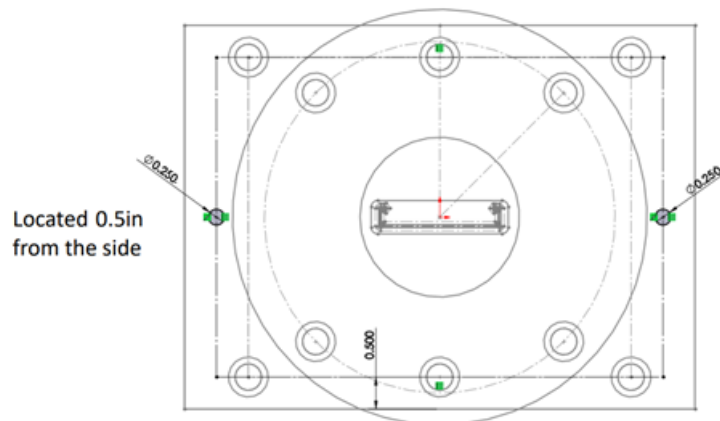
- Since the adapter plate is always a round plate, the location of the counterbore and clearance holes will be on a bolt center of diameter 1 inch less than adapter blank diameter and will be at the same location of the drill and tap holes on the adapter plate.



**Figure 3.68** Counterbore and clearance holes on a rectangular transition plate.

Source: New Jersey Precision Technologies

- Dowel hole placement for transition plate are also follow the same conditions applied for rectangular die plate as seen in Figure 3.40. Using these conditions place tap fit dowel holes at the calculated locations on the transition plate as seen in Figure 3.69.

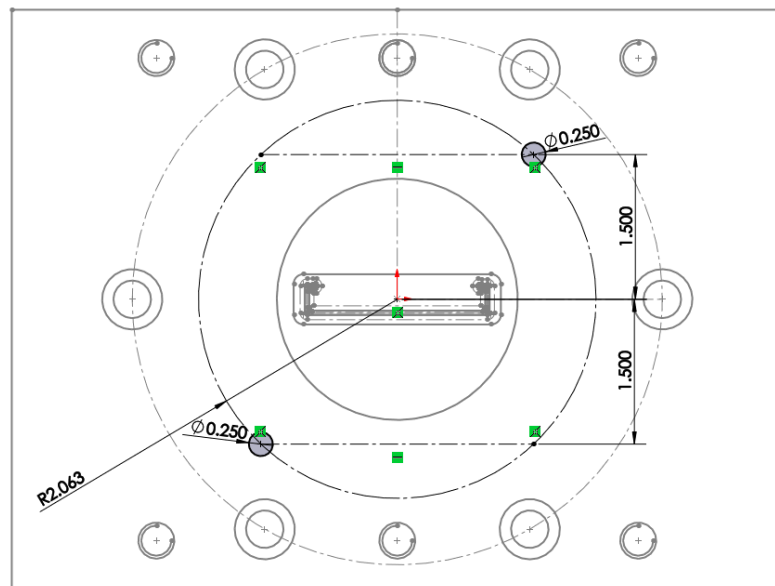


**Figure 3.69** Placing dowel holes that connect transition and die plate.

Source: New Jersey Precision Technologies



6. The positioning of the dowel hole for connecting rectangular transition plate and the adapter plate will follow the same constraints as for a round plate since the rectangular transition plate will always be attached to a round adapter plate. Dowel hole placement for transition plate are also follow the same conditions applied for round die plate as seen in Figure 3.33 and Figure 3.34. Using these conditions place tap fit dowel holes at the calculated locations on the adapter plate as seen in Figure 3.70.



**Figure 3.70** Placing dowel holes that connect trans and the adapter plate.

Source: New Jersey Precision Technologies

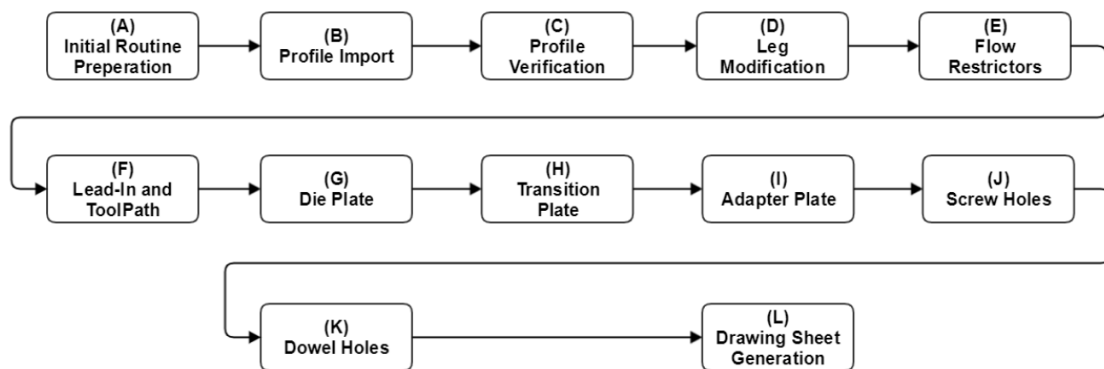
We now have understood and determined the overall steps involved in manually designing the die, adapter and the transition plates for any open channel extrusion profile. These steps were identified after interviewing the designers regarding the techniques they would use in order to design each plate. These techniques and methods were presented to the design team and was approved to be assigned as the standard operating protocol for extrusion tooling design.

## CHAPTER 4

### EXPERT SYSTEM DEVELOPMENT

#### 4.1 Compilation of Design Parameters

Once we set up the design protocols for the design of all the individual plates that make up the extrusion tooling assembly, we now have an understanding of all the various parameters that will need to be collected for initiating the automated design procedure. The key parameters will be the ones that are required to calculate the values of other parameters. The overall workflow of the automated extrusion tooling design program can be seen in Figure 4.1 and will aid us in identifying the parameters used for each process. Table 4.1 lists out all the parameters that are crucial in designing the extrusion tool and will be a part of the automation program to be used for designing all the features of the design. Most of the parameters listed in Table 4.1 are calculated parameters obtained by providing specifications supplied by the customer.



**Figure 4.1** Overall workflow of the automated extrusion tooling design program.

Source: New Jersey Precision Technologies

**Table 4.1** Compilation of Design Parameters Required for Automation

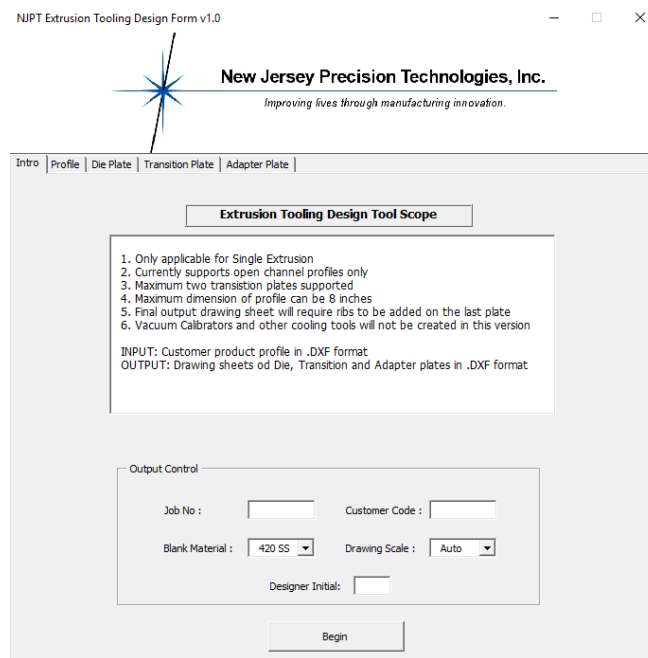
<b>ID</b>	<b>Activity</b>	<b>Parameters</b>
A	Initial Routine Preperation	<ol style="list-style-type: none"> <li>1. Wall thickness of product profile</li> <li>2. Gap tolerance for entities</li> <li>3. Extrudate material</li> <li>4. Drawdown percentage</li> <li>5. Wall thickness percentage</li> </ol>
B	Profile Import	<ol style="list-style-type: none"> <li>1. Product profile in DXF format</li> </ol>
C	Profile Verification	<ol style="list-style-type: none"> <li>1. Overall length of product profile</li> <li>2. Overall height of product profile</li> <li>3. Wall thickness of die exit profile</li> </ol>
D	Leg Modification	<ol style="list-style-type: none"> <li>1. Outward extension value for legs</li> <li>2. Inward extension value for legs</li> <li>3. Flare offset value for legs</li> </ol>
E	Flow Restrictors	<ol style="list-style-type: none"> <li>1. Flow restrictor diameter</li> <li>2. Inner corner</li> </ol>
F	Lead-in and Toolpath	<ol style="list-style-type: none"> <li>1. Type of lead-in</li> <li>2. Chamfer angle for chamfer lead-in</li> <li>3. Ball diameter for ball lead-in</li> </ol>
G	Die Plate	<ol style="list-style-type: none"> <li>1. Die blank shape</li> <li>2. Die blank thickness</li> <li>3. Diameter for round die blank</li> <li>4. Length for rectangular die blank</li> <li>5. Height for rectangular die blank</li> </ol>
H	Transition Plate	<ol style="list-style-type: none"> <li>1. Wire cutting angle</li> <li>2. Transition zone thickness</li> <li>3. Number of transition plates</li> </ol>

ID	Activity	Parameters
I	Adapter Plate	<ol style="list-style-type: none"> <li>1. Adapter plate thickness</li> <li>2. Adapter blank diameter</li> <li>3. Extruder outlet diameter</li> <li>4. Outlet profile shape selector for adapter</li> <li>5. Height for generic shape</li> <li>6. Length for generic shape</li> </ol>
J	Screw Holes	<ol style="list-style-type: none"> <li>1. Counterbore and clearance hole size for die plate</li> <li>2. Number of holes in die plate</li> <li>3. Counterbore and clearance hole size for transition plate</li> <li>4. Drill and tap hole size for transition plate</li> <li>5. Number of counterbore and clearance holes for transition plate</li> <li>6. Number of drill and tap holes for transition plate</li> <li>7. Drill and tap hole size for adapter plate</li> <li>8. Number of holes for adapter plate</li> </ol>
K	Dowel Holes	<ol style="list-style-type: none"> <li>1. Dowel size for die plate</li> <li>2. Dowel size for transition plate</li> <li>3. Dowel size for adapter plate</li> </ol>
L	Drawing Sheet	<ol style="list-style-type: none"> <li>1. Job number</li> <li>2. Customer code</li> <li>3. Blank material</li> <li>4. Drawing scale</li> <li>5. Designer initial</li> </ol>

Source: New Jersey Precision Technologies

## 4.2 Graphical User Interface

Once the design protocols for all the individual plates that make up the extrusion tool and the design parameters required have been identified, a GUI (Graphical User Interface) is established to portray a method by which the designers can interact with the program in an user friendly manner to enter the various specifications provided by the customer. Figure 4.2 shows the main extrusion tooling design form GUI.



**Figure 4.2** Intro page of the main extrusion tooling design form GUI.

Source: New Jersey Precision Technologies

The values entered by the designer will be used internally in the program to calculate all the other parameters that are essential in designing the die, transition and adapter plate. The GUI will also contain an information box that will provide basic description of all the parameters and their function in the program, so that designers will be able to easily distinguish them amongst all the entries in the GUI.

The program utilizes three graphical user interfaces, the first one will be the main interface that pops up when the designer runs the program. It is in this GUI that all the initial specifications from the customer is entered. The GUI on initializing will connect to a database that contains all the design parameters that have been derived from the main knowledge base containing successful design data of extrusion tooling. Figure 4.2 shows the first page of the GUI which will be the intro page that describes the scope of the project and is also where the designer will enter information regarding the project such as job number, customer code, blank material, drawing scale and designer initials. The next page of the GUI as seen in Figure 4.4, is dedicated for importing the profile and has inputs for all profile adjustment related parameters. The Browse button allows the user to select a product profile supplied by the customer in DXF format and clicking the Verify button will initialize a SolidWorks window, where the profile gets imported as two-dimensional sketch and its true center will be determined. After verification, values for overall length and height of the product profile will also be updated.

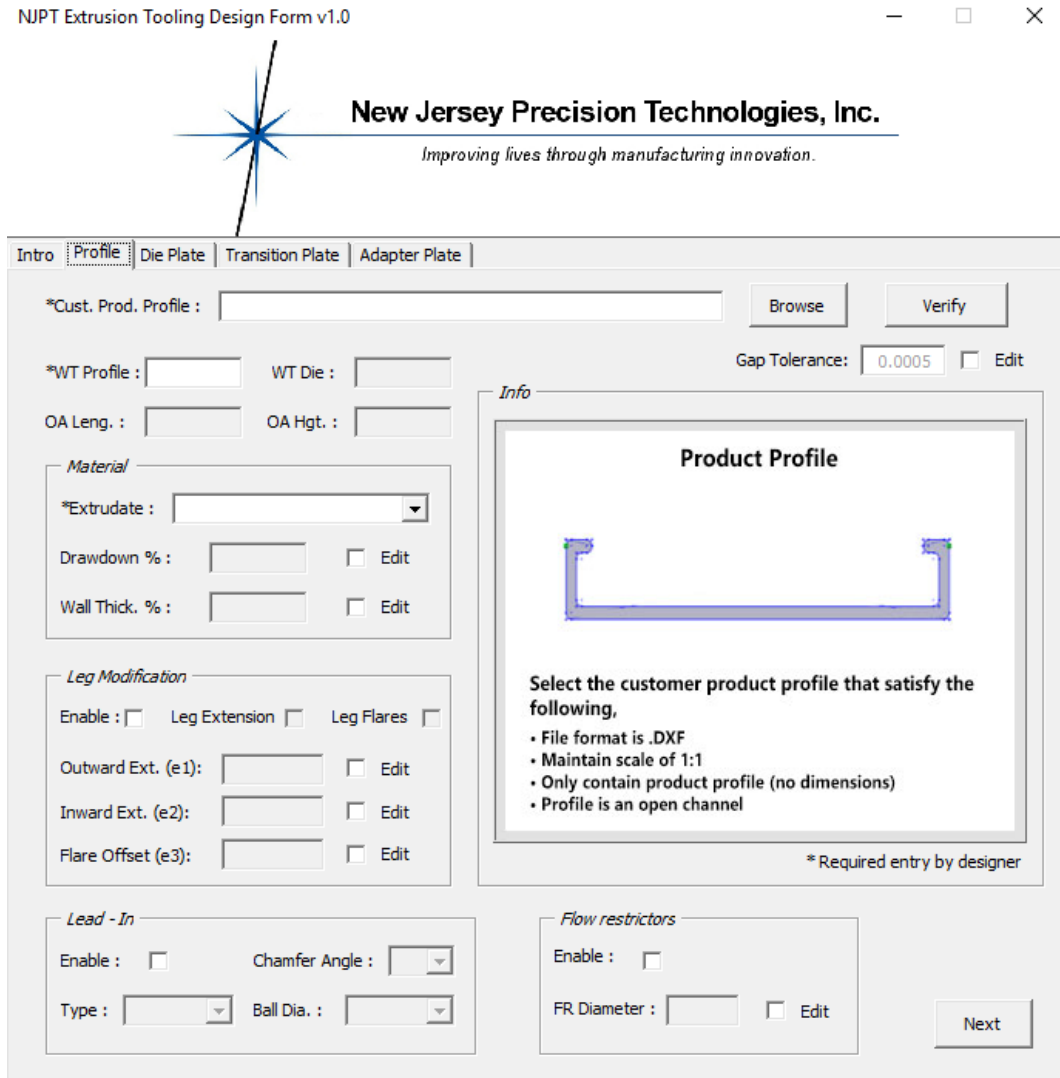
Material	Wall thickness %	Drawdown %	Chamfer Angle	Lead-In	Ball Diameter	Size	CBores
HIPS	9	30	60	Ball	0.0625	1/4-20	0.4370
HDPE	10	40	45	Chamfer	0.1250	5/16-18	0.5310
RPVC	8	20			0.1875	3/8-16	0.6250
ABS	10	25			0.2500	1/2-13	0.8130
Acrylic	15	28			0.3750		

CB Depth	Clearance	CL Depth	Drill	DR Depth	Tap	TP Depth	Adapter Outlet	Size	Tap Fit	Slip Fit
0.3700	0.2650	*	0.2030	0.6250	0.2500	0.5000	Round	1/4	0.2502	0.2510
0.4400	0.3280	*	0.2570	0.7500	0.3125	0.6300	Rectangle	3/8	0.3752	0.3760
0.5000	0.3900	*	0.3130	0.8750	0.3750	0.7500	HourGlass	1/2	0.5002	0.5010
0.6200	0.5150	*	0.4220	1.0000	0.5000	1.2500	Slot			
							Custom Offset			

**Figure 4.3** Design parameters derived from the knowledge base used by NJPT.

Source: New Jersey Precision Technologies



**Figure 4.4** Profile page of the main extrusion tooling design form GUI.

Source: New Jersey Precision Technologies

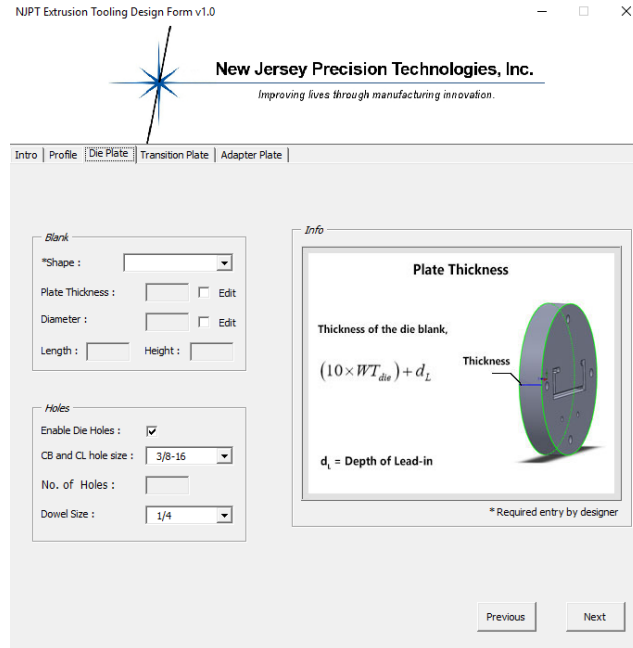
The entries marked with an asterisk are parameters that are required by the designers to enter either by inspecting the product profile or by requesting information from the customer before executing the program. This is the page where the designer will have to select the extrudate material the tool is being made for. Values for drawdown and wall thickness percentage are attained from the database shown in Figure 4.3.

Designers will also have the capability to turn off certain modules like leg modification, lead-in or flow restrictors in case the customer does not require them and in that case, the excluded module will not be considered in the program execution and will be skipped. All the values that are calculated within the program will not be editable by default and the designer will need to select the Edit button placed to the right of each calculated value in order to modify it. This is done so that designers will be able to change the default calculated values based on the design protocols of each plate only when it is necessary or if provided specific values by the customer.

Figures 4.5, 4.6 and 4.7 show the next three pages in the GUI which follows a similar format and it contains a section where the designer can assign blank parameters like shape and dimensions. The wire cutting angle for the transition plate can be varied but a default value based on the protocol will be provided in case the designer does not have any information regarding the suitable value.

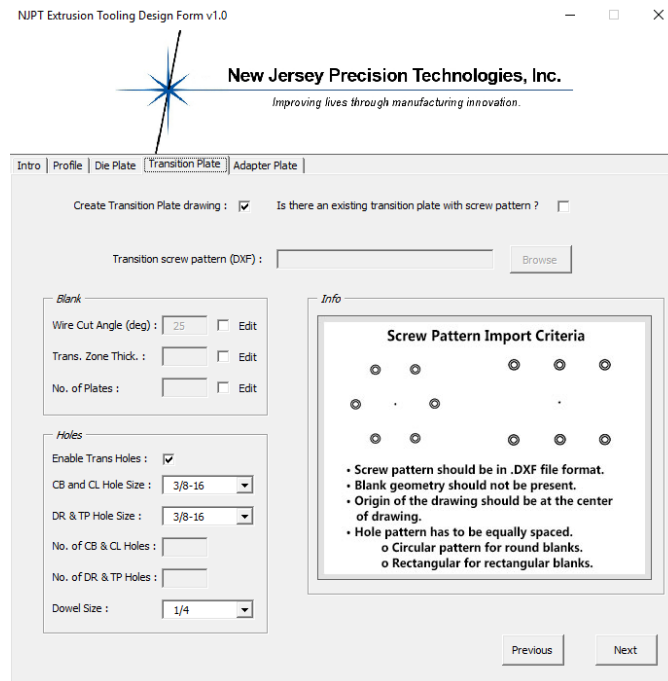
Based on the wire cutting angle, the transition zone thickness and the number of plates will be determined. The next section common for all the three pages are the holes, where designer can select the size from a standard set of screw hole sizes commonly used as shown in Table 2.2 and dowel holes sizes as shown in Table 2.3. The number of holes is calculated based on the assigned dimension for the blanks and the minimum safe required number of holes to prevent any kind of polymer leakage between the plates will be determined.





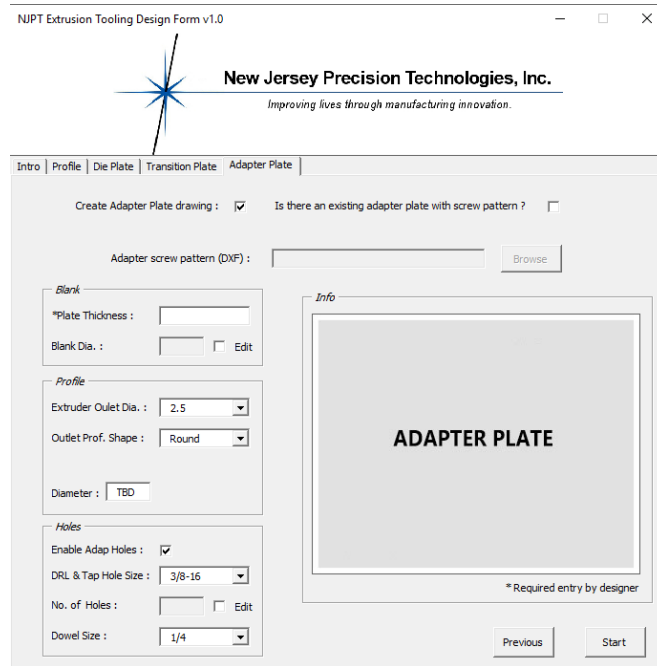
**Figure 4.5** Page of extrusion tooling design form GUI that deals with Die plate.

Source: New Jersey Precision Technologies



**Figure 4.6** Page of extrusion tooling design form GUI that deals with Transition plate.

Source: New Jersey Precision Technologies



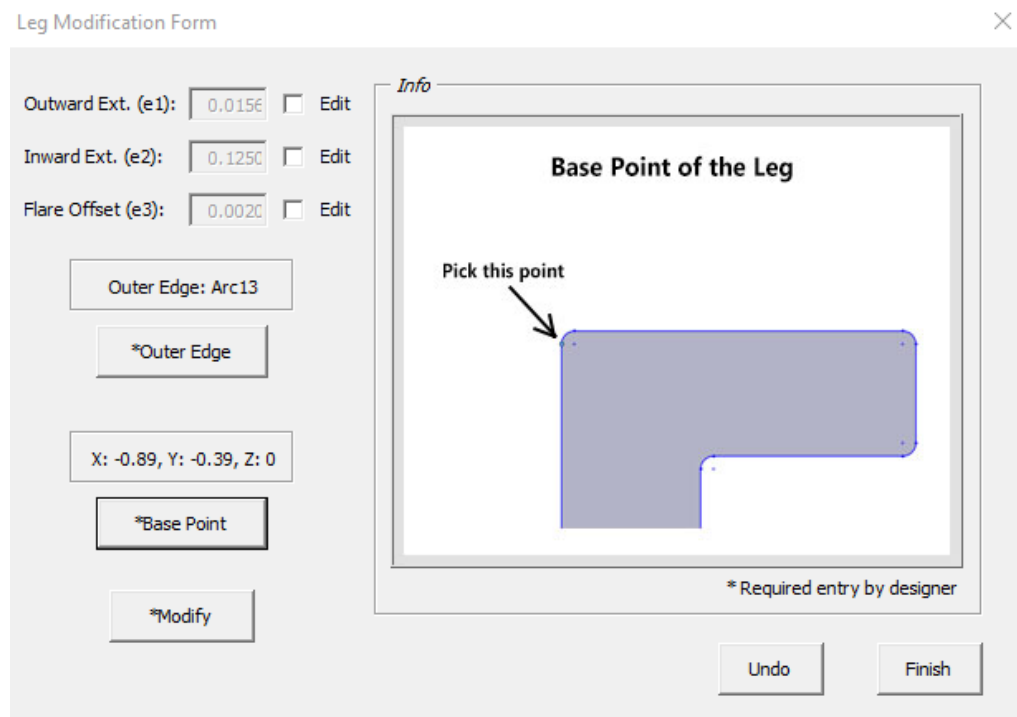
**Figure 4.7** Page of extrusion tooling design form GUI that deals with Adapter plate.

Source: New Jersey Precision Technologies

Since the customers sometimes require their holes to be located at custom locations and will not always follow the standard hole pattern programmed, an additional functionality has been added where the designer will be able to import a custom hole pattern into the program for either or both the transition and the adapter plate. The program will be able to recognize the position of these holes and arrange the holes for the rest of the plates appropriately. Once all the entries in the GUI has been filled and automatically calculated, the designer will have to press the Start button to begin executing the design.

Once the design has begun, the next graphical user interface that the designer comes across is the leg modification form as seen in Figure 4.8. This form will show up only if the leg modifications module was enabled in the main extrusion tooling design GUI. In the leg modification form, the design will have buttons to select the outer edge and the base

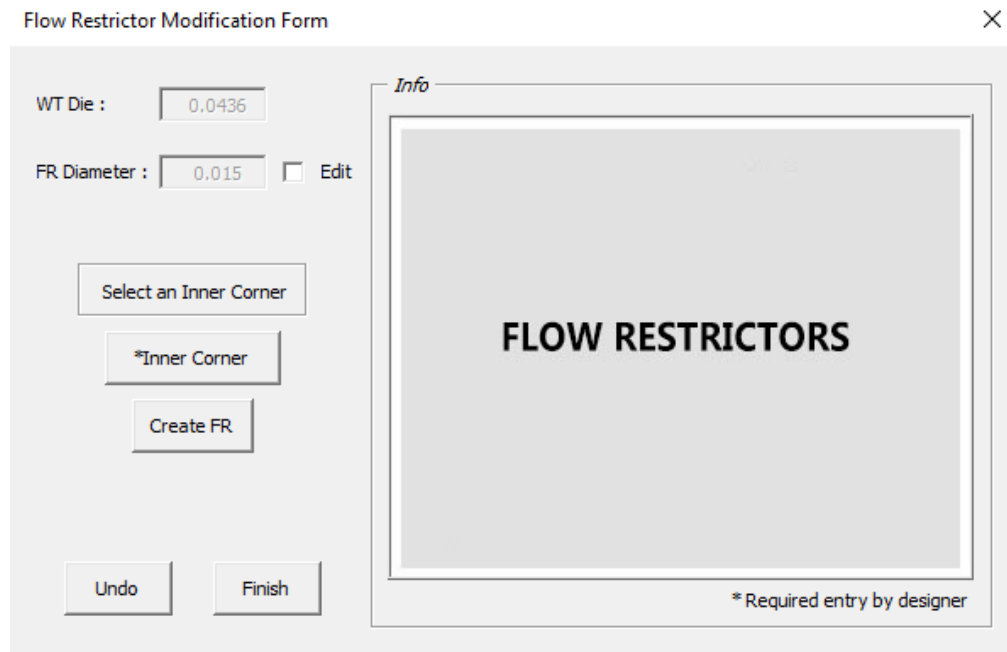
point of the leg that they need to modify. The selected entities will show up on the form at the corresponding locations after the button for outer edge and base point have been pressed. Once the entities have been selected, clicking on the Modify button will automatically adjust the leg based on the extension and offset values. The values supplied for outward extension, inward extension and flare offset are carried over from the main form and can be edited by the designer for each leg if they choose to do so. There is also an Undo button which allows the designer to revert the designed modifications in case they do not like how it turned out to be modified.



**Figure 4.8** GUI showing the leg modification form for the extrusion profile.

Source: New Jersey Precision Technologies

After the leg modifications have concluded, if the flow restrictor module was enabled in the main extrusion tooling design GUI, then the flow restrictor modification form as shown in Figure 4.9 will show up. In this form the designer will have to select a and specify the inner corner at which the flow restrictor needs to be created. The designer also has the option to modify the flow restrictor diameter for each corner if he or she wishes to do so. Selecting an inner corner in the model view window and clicking on the inner corner will update the entity name and then clicking the Create FR button will automatically design and create a flow restrictor at the selected corner. The designer also has the ability to undo the created flow restrictor using the Undo button in case they want to change the parameters and try again.



**Figure 4.9** GUI showing the flow restrictor modification form for the extrusion profile.

Source: New Jersey Precision Technologies

### 4.3 Routine Methods

The automated extrusion tooling design program is created using Visual Basic within SolidWorks with the help of the built-in SolidWorks API that allows us to control every aspect of the program and use it to make the designs that were done manually to be automated. The parameters used for each of the design steps were obtained from creating a standard working protocol after analyzing the organization workflow at NJPT and the methodologies their designs used to produce successful designs for manufacturing of extrusion die, transition and adapter plates. The overall design process was categorized into sub roles, as seen in Figure 4.1, that were fundamental to the overall design and automation routines were created to mimic them. Table 4.2 lists out the names of all the routines used and a brief description regarding their purpose.

**Table 4.2** Compilation of Routines Used in Automated Extrusion Tool Design Program

Routine Name	Description
ExtToolMain	Sets up connection with SolidWorks and the referenced documents which include the excel knowledge base and info box reference pictures.
DXFImport	Imports selected .DXF file as a new part on SolidWorks.
PolygonFix	Repairs the sketch and arranges all the segments in such a way that their end point is connected to the start point of the next segment.
TrueCenter	Determines the midpoint of the profile and will align the sketch so that the midpoint lies on the origin.
profScaleDDA	Scales the profile up according to the drawdown percentage of the extrudate.
profWTAdj	Adjusts the walls of the profile to account for die swell.

<b>Routine Name</b>	<b>Description</b>
LegMod	Add flares or extensions or both to the ends of the legs depending on selection.
FlowRestrictor	Creates flow restrictors at designer selected locations.
LeadIn	Designs chamfer or ball lead-in for the profile based on designer preference.
ToolPath	Creates a toolpath if the type of lead-in selected is ball lead-in.
Trans1Outlet	Creates the outlet profile for the transition plate attached to the die plate.
TransPlateNo	Depending on the number of transition plate, the routine will create the corresponding number of planes for a single or double transition plates.
AdapInlet	Designs the inlet profile for the adapter plate based on extruder specifications.
AdapOutlet	Designs the outlet profile for the adapter plate depending on designer preference.
Trans2Inlet	In case there are two transition plates, this routine will design the inlet profile for the transition plate lying next to the adapter plate.
Trans2Outlet	In case there are two transition plates, this routine will design the outlet profile for the transition plate lying next to the adapter plate.
Trans1Inlet	Designs the inlet profile for the transition plate lying next to the die plate.
DieBlank	Designs the blank geometry for die plate.
TransBlank	Designs the blank geometry for transition plate.
AdapBlank	Designs the blank geometry for adapter plate.
AdapHoles	Creates or imports screw hole pattern on the adapter plate.

<b>Routine Name</b>	<b>Description</b>
TransHoles	Creates or imports screw hole pattern on the transition plate.
DieHoles	Creates screw hole pattern on the die plate.
DowelH	Designs dowel holes for the die, transition and adapter plate.
DwgPrep	Initializes SolidWorks drawing sheet and loads the referenced drawing template used by NJPT.
DwgDie	Creates drawing sheet for the die plate and adds dimensions and notes.
DwgTrans	Creates drawing sheet for the transition plate lying next to the adapter plate and adds dimensions and notes.
DwgTrans2	Creates drawing sheet for the transition plate lying next to the die plate and adds dimensions and notes.
DwgAdap	Creates drawing sheet for the adapter plate and adds dimensions and notes. Finally exports all the drawing sheets as DXF output sheets which are the desired output.

Source: New Jersey Precision Technologies

#### **4.3.1 Routine: ExtToolMain**

When the program is run, the main routine named ExtToolMain is executed which is responsible for initializing connections with SolidWorks, the Excel database containing all the knowledge parameters which will be used for the design and the information pictures that are used as helpful pointers in the graphical user interface when the designer hovers over a parameter. Once the connections have been established successfully, the program will show the user the main extrusion tooling design form graphical user interface as seen in Figure 4.2.

### **4.3.2 Routine: DXFImport**

This routine makes use of the SolidWorks API function LoadFile4 to import a DXF file into a two-dimensional sketch file. The conditions of the file are,

- File has to be in DXF format.
- File has to contain only profile sketch segments and no boundaries, title block or dimensions.
- The scale of the profile inside the file should be 1:1.

This routine is initiated when the designer browses for the product profile and clicks the Verify button in the GUI as seen in Figure 4.4. The routine code can be found in Appendix B.

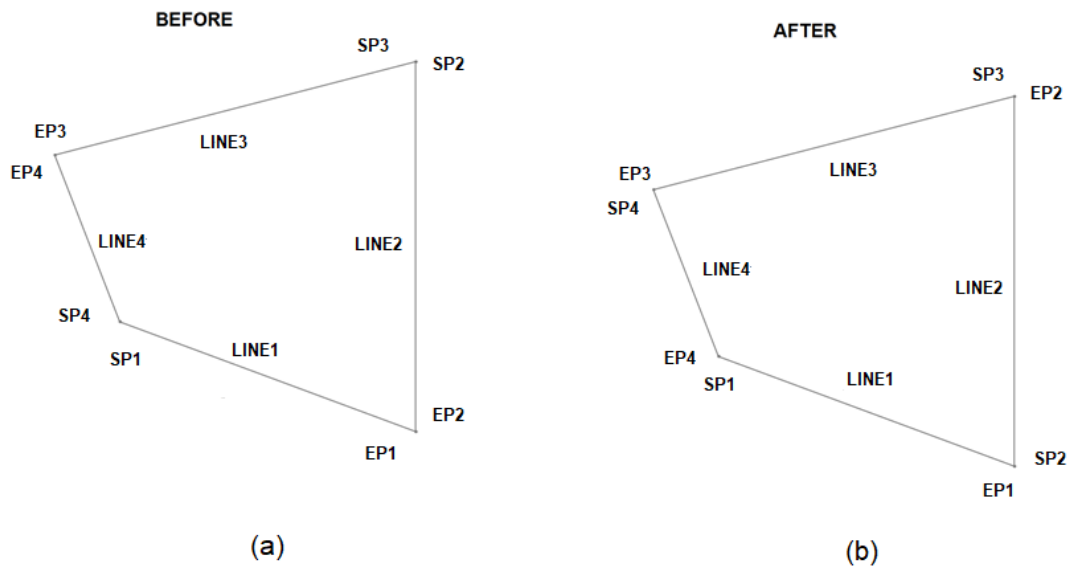
### **4.3.3 Routine: PolygonFix**

As the name suggests the main function of the routine is to fix or rearrange the polygon in such a way that all the entities that are connected to each other in the polygon follow a counter-clockwise with respect to their start points and end points of each entity.

This arrangement is required because if the sketch was arranged with each of its entities following different directions as shown in Figure 4.10 (a) all the further calculations done in the program will give random results. In Solidworks, a line segment can appear to be at the same location on the screen but it can have two orientations, one at a certain angle with respect to x-axis and the other at 180 degrees subtracted from that angle. If the segment oriented in the first direction is given a translational value of a random positive integer, the direction the segment will translate to will not be the same direction the same segment with an inverted orientation will move to. Instead, it will translate to the



opposite direction. Moreover, the aim of PolygonFix is to also output an array of sketch segments connected in order so it becomes easier to identify which segments lie to the left and right of the selected segment and thus makes calculations much easier. Figure 4.10(b) shows how the closed loop polygon was rearranged so that all the segments follow a counter-clockwise path. SP stands for the starting point of the segment and EP stands for the end point of the corresponding segment.



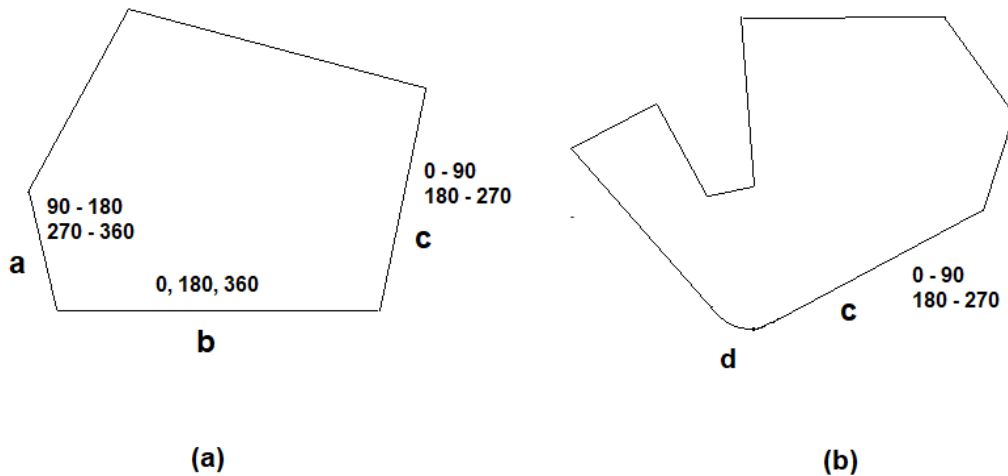
**Figure 4.10** (a) Polygon having segments in random orientations, (b) Polygon whose segments are arranged in a counterclockwise direction connected to each other.

Source: New Jersey Precision Technologies

During the process of rearranging the polygon sketch segments, the routine is also able to solve other problems that can occur in sketch files like disjointed entities, overlapping entities and also removing 0 length entities from the sketch that could appear in the DXF file due to conversion from old file versions.

The algorithm for the routine starts from determining the base segment of the sketch profile. To determine the base segment,

1. Using SolidWorks API function GetSketchSegments(), we get an array containing all the sketch segments in the active sketch.
2. Determine the lowest point or the point having the minimum y value in the sketch.
3. Ensure that the minimum y value is not the center of an arc since the center point of an arc will never be connected to the base segment.
4. Loop through the array in the first step to obtain an array of all the entities that has its start or end point located at the minimum y-value and identify them as a, b, or c based on their orientation angle as shown in Figure 4.11(a) and (b). The tag a will refer to segments whose angle is between 90 to 180 or 270 to 360; b to segments whose angle is either 0, 180 or 360; c will refer to segments whose angle is between 0 to 90 or 180 to 270; d will be assigned to any arcs whose start or end points correspond to the minimum y value.
5. Using a priority selection algorithm as shown in Table 4.3, base segment is found.



**Figure 4.11** (a) Polygon having 3 possible base segments, (b) Polygon having two possible base segments.

Source: New Jersey Precision Technologies

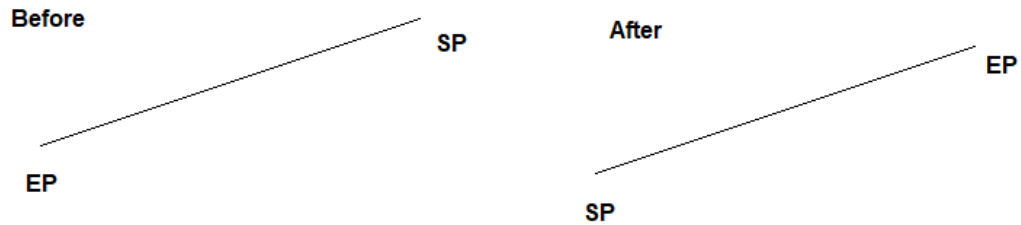
**Table 4.3** Priority Selection Algorithm for Base Segment of The Profile

<b>A</b>	<b>b</b>	<b>c</b>	<b>d</b>	<b>Base</b>
0	0	0	0	No base
0	0	0	1	d
0	0	1	0	c
0	0	1	1	c
0	1	0	0	b
0	1	0	1	b
0	1	1	0	b
0	1	1	1	b
1	0	0	0	a
1	0	0	1	a
1	0	1	0	c
1	0	1	1	c
1	1	0	0	b
1	1	0	1	b
1	1	1	0	b
1	1	1	1	b

---

Source: New Jersey Precision Technologies

Once the base segment has been determined, we check its orientation to see if it goes in the clockwise or counter-clockwise direction as seen in Figure 4.12, if it is in the clockwise direction, we invert it to counter clockwise.



**Figure 4.12** Inverting a segment to be oriented in a counter-clockwise direction.

Source: New Jersey Precision Technologies

After the base segment has been oriented correctly, we assign that to be the first segment in our final output array. Next we use our confirmed base start point and end point coordinates to identify the next segment attached to it (line or arc) using the following condition,

$$(Base\_Endpt = Segment\_endpt) \text{ OR } (Base\_Endpt = Segment\_startpt) \quad (4.1)$$

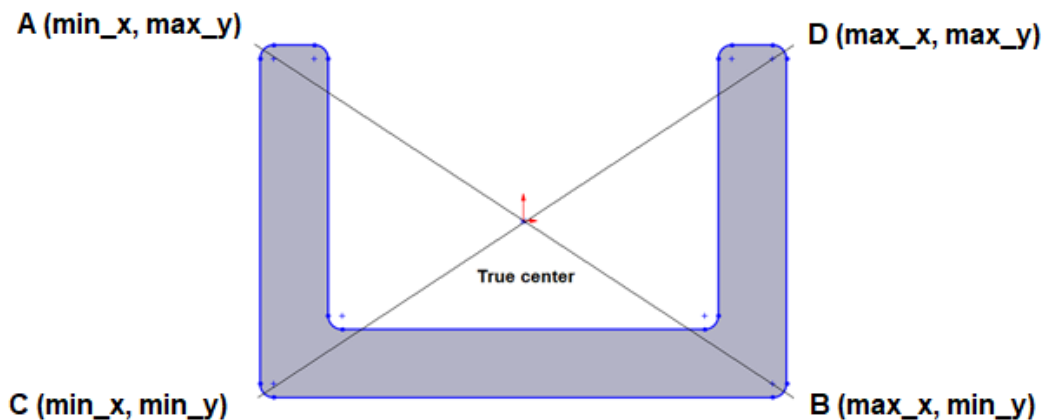
The OR condition is applied since the orientation of the next segment can be correct or inverted and if it is inverted, we rearrange the start and end points of the segment and create it in the correct order. Next we use the SolidWorks merge relation to ensure that the points are connected to each other so that there won't be any disjointed entities. This corrected segment will be the second segment in our final output array and it will be used to determine the next segment. This process is repeated iteratively to obtain the final output array and rearranging the sketch so that all the entities follow a counter-clockwise direction from the base segment. The complete routine code can be found in Appendix B.

#### 4.3.4 Routine: TrueCenter

The function of this routine is to identify the geometric center of the profile since it is required as a point from which we will need to scale our profile as well as to accurately position the profile with respect to the extrusion blanks and holes in our final drawing sheet.

The algorithm involved in determining the geometric center involves,

1. Iterate through to sketch to determine if there are any arcs in the profile. Since arcs in SolidWorks do not supply point information at the maximum and minimum locations, points are created at the +x, +y, -x and -y direction at a radial distance if they lie on the arc.
2. Using SolidWorks API function GetSketchPoints2(), we can get an array of all the points that exist in the sketch, with which we can determine the maximum and minimum values of x and y coordinates in the array.
3. Next we can create a bounding box with the help of the determined coordinates as seen in Figure 4.13. The geometric center of the profile will be the intersection of the diagonals of this bounding box.



**Figure 4.13** Determining true geometric center of a sketch profile.

Source: New Jersey Precision Technologies

The point of intersection between the two diagonal lines as shown in Figure 4.13 can be found using the following general approach. Since we have the end points of each of the diagonal, we obtain the equation of the lines of each of the diagonals in slope intercept form. If the equations of the two lines can be identified as,

$$a_1x + b_1y + c_1 = 0 \quad (4.2)$$

$$a_2x + b_2y + c_2 = 0 \quad (4.3)$$

As seen in Figure 4.13, coordinates of endpoints are, A (min\_x,max\_y), C (min\_x, min\_y), D (max\_x, min\_y) and B (max\_x, min\_y). The equations are solved to get the common solution value for both the equations and this will be the point of intersection.

$$x = \frac{\begin{vmatrix} -c_1 & b_1 \\ -c_2 & b_2 \end{vmatrix}}{\begin{vmatrix} a_1 & b_1 \\ a_2 & b_2 \end{vmatrix}} = \frac{b_1c_2 - b_2c_1}{a_1b_2 - a_2b_1} \quad (4.4)$$

$$y = \frac{\begin{vmatrix} a_1 & -c_1 \\ a_2 & -c_2 \end{vmatrix}}{\begin{vmatrix} a_1 & b_1 \\ a_2 & b_2 \end{vmatrix}} = \frac{a_2c_1 - a_1c_2}{a_1b_2 - a_2b_1} \quad (4.5)$$

If  $a_1b_2 - a_2b_1 = 0$  then it implies that the two lines are parallel and, in that case,, the geometric center will not be found and then we use the function AlignSketch() to align the whole sketch so that origin will be moved to the determined geometric center of the profile. The complete code for this routine can be found in the Appendix B.

#### **4.3.5 Routine: profScaleDDA**

In this routine, the profile is scaled up according the drawdown percentage value that is represented in the GUI based on customer selection of the extrudate. This is a simple routine done with the help of the SolidWorks API function called SketchModifyScale(scalefactor) where scale factor is the value of drawdown percentage. We use the SelectAll() function to select all the entities and then use SketchModifyScale(scalefactor) to scale it up about the geometric center. This scaled profile will be named as a new sketch with the name “Intermediate Profile”.

#### **4.3.6 Routine: profWTAdj**

To account for die swell, we need to adjust the wall thickness of the profile based on the wall thickness percentage that has been calculated for the extrudate as per the standard design protocol. This routine first selects one of the entities of the profile and then uses the API function called SketchOffset2 to offset all the segments connected in chain as per the wall thickness offset value provided to it by the GUI. This offset profile is pasted on a new sketch and is named “Adjusted Profile”.

#### **4.3.7 Routine: LegMod**

This routine is used to modify the legs of the plastic extrusion profile to add flares and/or extensions as per the choice made by the designer in the main design GUI. The routine will initially perform a check if the leg modification module has been enabled within the GUI and will proceed only if it has, else it will skip to the FlowRestrictor module.

The first thing the routine will do is hide the main extrusion tooling design form GUI and show the leg modification GUI as seen in Figure 3.9. Once has made selections for the Outer Edge and the Base Point of the leg and clicks on the Modify button, the routine will store the entities selected by the designer and store them in memory. The routine will first determine the length of the leg using the appropriate formula depending on the type of the selected Outer Edge.

- If the Outer Edge is a line segment, the distance between the base point and the Outer Edge can be determined using the following formula, where if a line passes through two points  $P_1(x_1, y_1)$  and  $P_2(x_2, y_2)$  then the distance of  $(x_0, y_0)$  from the line is,

$$\text{distance}(P_1, P_2, (x_0, y_0)) = \frac{|(y_2 - y_1)x_0 - (x_2 - x_1)y_0 + x_2y_1 - y_2x_1|}{\sqrt{(y_2 - y_1)^2 + (x_2 - x_1)^2}} \quad (4.6)$$

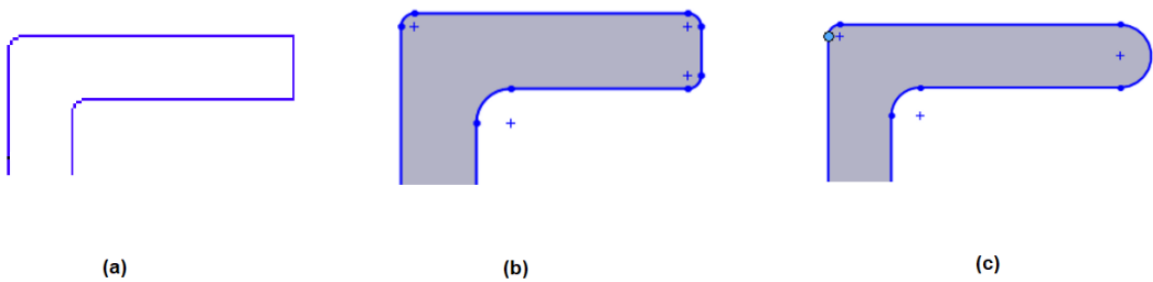
- If the Outer Edge is an arc, the distance between the base point and the Outer Edge can be determined using the following formula, where  $C_x$  and  $C_y$  are the x and y coordinates of the Outer Edge center and  $x_0$  and  $y_0$  refer to the Base Point and radius is the radius of the Outer Edge.

$$\text{distance}(C_x, C_y, (x_0, y_0)) = \sqrt{(x_0 - C_x)^2 + (y_0 - C_y)^2} + \text{radius} \quad (4.7)$$

This calculated length is stored in memory for the leg. Next the routine will analyze the entities of the leg and determine what type of leg it is as shown in Figure 4.14. This is achieved by determining the adjacent entities connected to the Outer Edge segment. If the Outer Edge segment is an arc then it automatically is categorized as Type 3. However, if



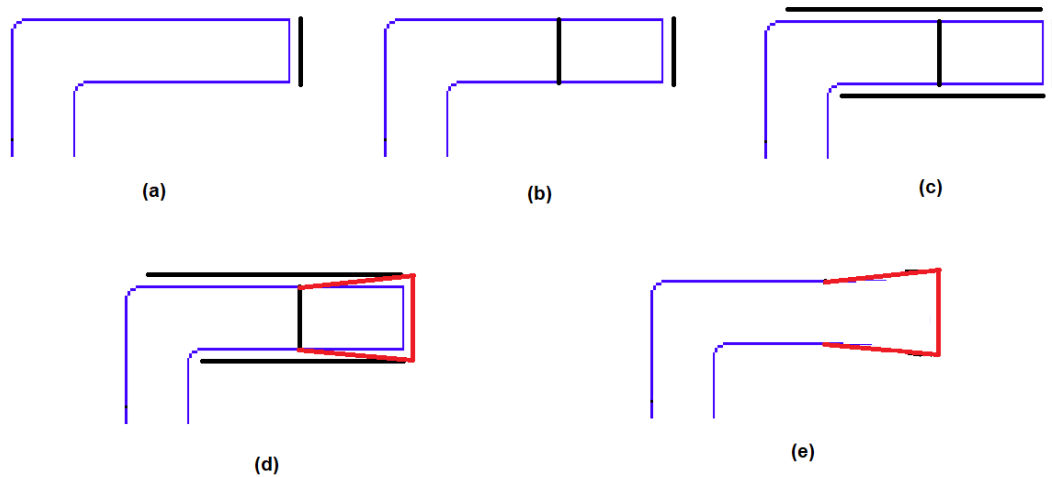
the Outer Edge is a line segment, then the start and end points of the Outer Edge is compared to all the start and end points of the entities in the sketch and the segments that are connected adjacently to its left and right are found. If the adjacent segments on the left and right of the Outer Edge are line segments too then the leg is categorized as Type 1, else if the adjacent left and right segments were found to be arcs, then the leg is categorized as Type 2.



**Figure 4.14** (a) Leg with flat ends, Type 1, (b) Leg with flat end and curved corner radii, Type 2, (c) Leg with curved end or full radii, Type 3.

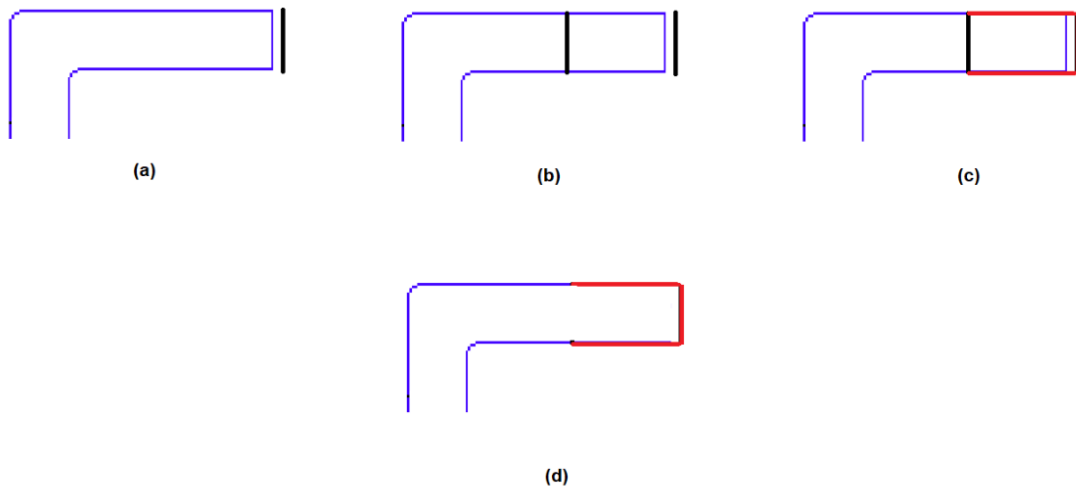
Source: New Jersey Precision Technologies

Depending on the choice made by the designer regarding type of modification and the calculated length of the leg the routine will proceed to modify the legs as shown in the figures below.



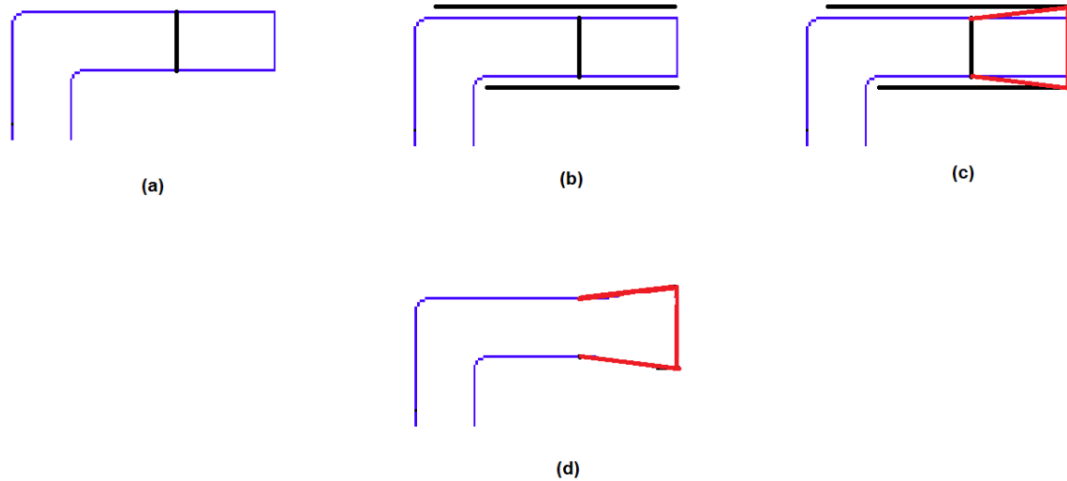
**Figure 4.15** Leg modifications for a Type 1 leg with length greater than  $\frac{3}{8}$  in and having flares and extensions, (a) The outer edge is extended outwards, (b) Outer edge is offset inwards, (c) Sides of the leg are offset sideways to add flares, (d) Lines are joined at the points of intersections, (e) Unwanted lines are trimmed to get the modified leg.

Source: New Jersey Precision Technologies



**Figure 4.16** Leg modifications for a Type 1 leg with length greater than  $\frac{3}{8}$  in and having only extensions, (a) The outer edge is extended outwards, (b) Outer edge is offset inwards, (c) Lines are joined at the points of intersections, (d) Unwanted lines are trimmed to get the modified leg.

Source: New Jersey Precision Technologies

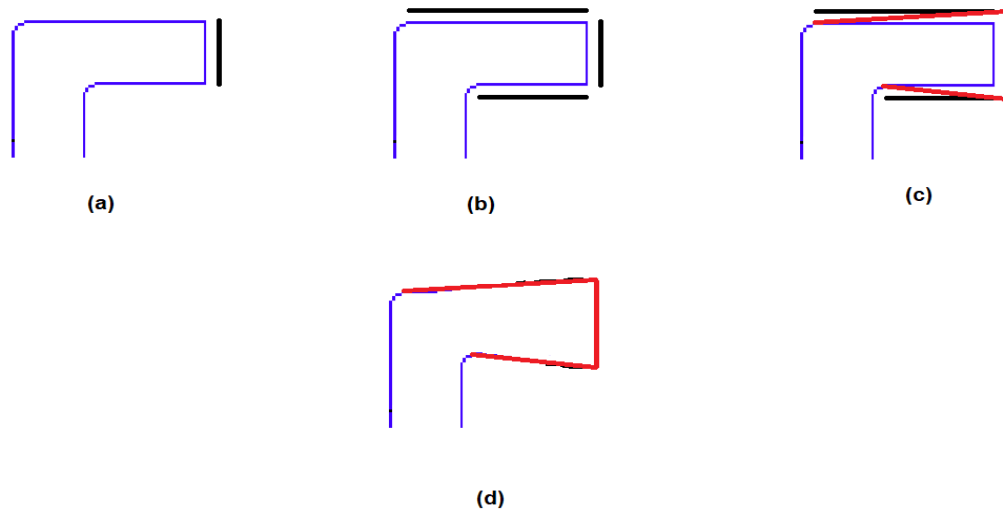


**Figure 4.17** Leg modifications for a Type 1 leg with length greater than 3/8 in and having only flares, (a) Outer edge is offset inwards, (b) Sides of the leg are offset sideways to add flares, (c) Lines are joined at the points of intersections, (d) Unwanted lines are trimmed to get the modified leg.

Source: New Jersey Precision Technologies

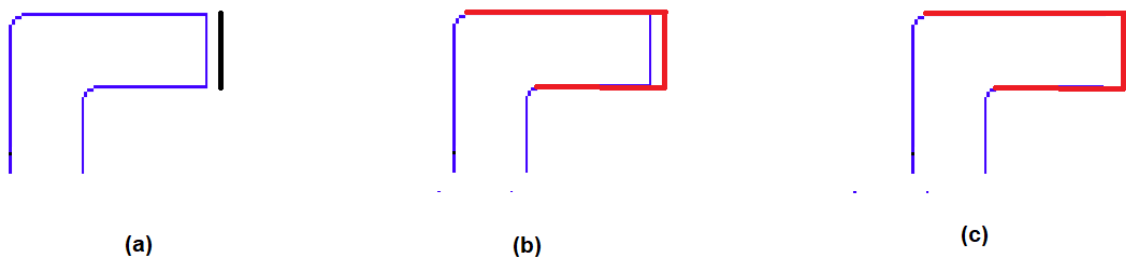
When the length of the leg is less than 3/8 inches, we do not extend the leg inwards instead, when we create lines to join the points of intersections, instead of the inward offset points, we use the base points of the leg as seen in the figures below.

In the case of type 2, the only additional step is that the original corner radii that the leg had will be added at the corners once the legs are modified and for type 3 legs, the only difference is the type of segment will be an arc instead of a line. The main API functions used in this routine are the `CreateLine()` and `TrimSketchEntities()` which are responsible for drawing lines from one coordinate to the other and trimming sketch entities based on coordinates supplied. The points of intersections are found using the same algorithm used in the `TrueCenter` routine to find the point of intersection between the diagonals of the bounding box. The code for this routine can be found in the Appendix B.



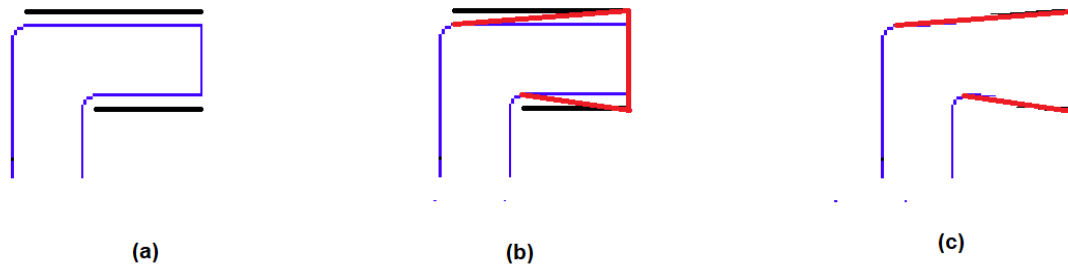
**Figure 4.18** Leg modifications for a Type 1 leg with length less than  $3/8$  in and having flares and extensions, (a) The outer edge is extended outwards, (b) Sides of the leg are offset sideways to add flares, (c) Lines are joined at the points of intersections and base points of the leg, (d) Unwanted lines are trimmed to get the modified leg.

Source: New Jersey Precision Technologies



**Figure 4.19** Leg modifications for a Type 1 leg with length less than  $3/8$  in and having only extensions, (a) The outer edge is extended outwards, (b) Lines are joined at the points of intersections and base points of the leg, (c) Unwanted lines are trimmed to get the modified leg.

Source: New Jersey Precision Technologies



**Figure 4.20** Leg modifications for a Type 1 leg with length less than  $3/8$  in and having only flares, (a) Sides of the leg are offset sideways to add flares, (b) Lines are joined at the points of intersections and base points of the leg, (c) Unwanted lines are trimmed to get the modified leg.

Source: New Jersey Precision Technologies

#### 4.3.8 Routine: FlowRestrictor

This routine is used to add flow restrictors at the joints of the extrusion profile. The routine will initially perform a check if the flow restrictor module has been enabled within the GUI and will proceed only if it has, else it will skip to the LeadIn module.

As soon as the routine starts executing, it will pull up the flow restrictor modification form GUI as seen in Figure 4.9. When the designer selects a segment or point located at the joint and clicks on the Inner Corner button, the routine will store the segment or point into memory and display the name of the segment in the GUI using the GetName() function. After designer verifies the correct segment or point has been displayed and clicks on the Create FR button, depending on the type of inner corner it will perform the following steps

1. Determine the lines or arcs connected adjacently to the left and right of the point.
2. Get the point of intersection created by the adjacent lines, point B as seen in Figure 4.21.

3. We can determine the value of AB as seen in the Figure 4.21, by using Pythagoras theorem since we know the value of the wall thickness,

$$AB = \sqrt{2}WT_{die} \quad (4.8)$$

4. We also know that as per design protocol, distance between flow restrictor and the opposite corner should be the value of wall thickness, however we are assuming that if the opposite corner is an arc, the clearance created between an arc and a point in the same place would be very small. Hence AC is assumed to be the same as  $WT_{die}$ . We also know the value of OC which will be the radius of the flow restrictor diameter ( $R_{FR}$ ) calculated in the main extrusion tooling design form GUI.
5. We can thus get the value of OB with the following formula,

$$OB = AB - AO \quad (4.9)$$

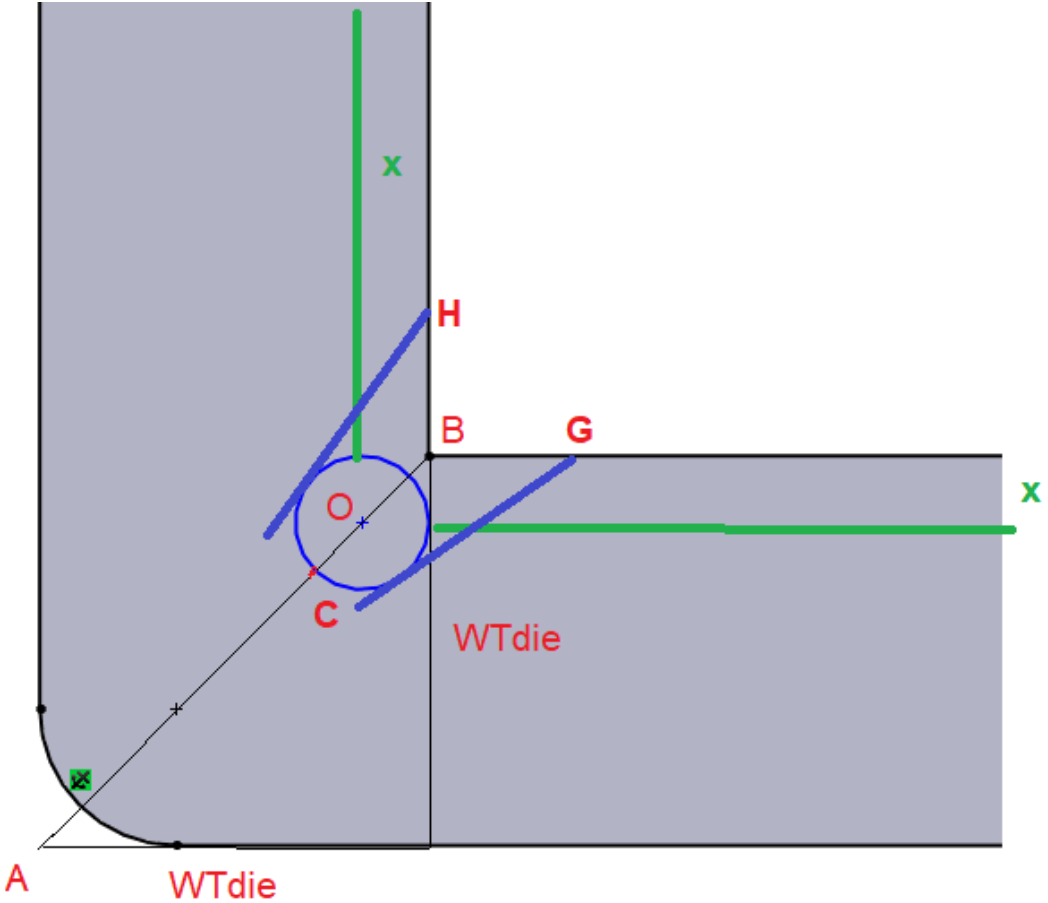
$$OB = \sqrt{2}WT_{die} - (WT_{die} + R_{FR}) \quad (4.10)$$

6. Using Pythagoras theorem again, we can determine the value of x from the calculated value of OB as shown below,

$$x = \frac{2WT_{die} - \sqrt{2}(WT_{die} + R_{FR})}{2} \quad (4.11)$$

7. We offset the adjacent legs calculated in step 1 by a distance equal to the calculated value of x.

8. Next we find the point of intersection of the newly offset legs and this will give us the location for the center of the flow restrictor and we draw a circle at the point using CreateCircle() API function.
9. We know that the value of BH and BG is the same as the flow restrictor diameter value, we locate those points and we create a line from each point such that they are lying tangent to the flow restrictor circle as seen in Figure 4.21.
10. Finally, we trim all the unwanted lines to get the flow restrictor.



**Figure 4.21** Routine steps for creating a flow restrictor at the joints of a profile.

Source: New Jersey Precision Technologies

#### 4.3.9 Routine: LeadIn and ToolPath

This routine is used to add a lead-in to the extrusion profile, either a ball or a chamfer lead-in depending on designer selection in the main extrusion tooling design form GUI. The routine will initially check if the lead-in module was enabled in the main GUI and will only execute if it was enabled else it will proceed with the rest of the program.

The routine begins by creating a new plane called Die inlet plane located at a distance of the die plate thickness calculated in the main GUI and a new sketch will be created on it called the Lead in profile. Since the process of adding a lead-in involves offsetting the entire profile path outwards at a distance of  $L_{\text{offset}}$  calculated in the design protocol, we have added a small failsafe to prevent any possibility of singularity occurrence which means, if an arc on the profile becomes a point after offset. To prevent this from happening we add fillets to the profile at all the corners. For chamfer lead-in we just add a fillet of 0.0001 inches just to prevent occurrence of a singularity but for a ball lead-in this fillet value will be modified so that after the offset, the radii of the offset will be equal to the radius of the ball end mill used to manufacture the lead-in, which is the difference of the ball end mill radius and the calculated  $L_{\text{offset}}$  value with a tolerance of 0.0005 inches.

$$\text{Fillet\_radius}_{\text{Chamfer}} = 0.0001in \quad (4.12)$$

$$\text{Fillet\_radius}_{\text{Ball}} = \text{Ball\_mill\_radius} - L_{\text{offset}} \quad (4.13)$$

Next we offset the entire chain connected segments of the extrusion profile outwards with a distance of  $L_{\text{offset}}$  to obtain the lead-in of the extrusion profile. The functions used for offset is the SketchOffset2() from the SolidWorks API. The value of  $L_{\text{offset}}$  will be different for ball and chamfer lead-in and is obtained from the calculation



perform in the front-end main extrusion tooling design form GUI. The lead in profile will finally be renamed as the die inlet profile. If lead-in module was disabled and flow restrictor module was enabled, the flow restrictor profile will be the die inlet profile. In case both the lead-in and the flow restrictor module were disabled, the adjusted profile will be copied on to a new sketch called die inlet profile located at the thickness value of the die plate.

The toolpath routine will be executed only if the lead-in designed was a ball lead-in. It too begins with creating a new sketch called Toolpath and copies the Adjusted profile sketch onto it. Next it creates fillets of radius 0.0001 inch at all the ends of the segments so as to prevent any possibility of singularity during offset. Finally, it uses the offset value calculated to offset the sketch inwards using the SketchOffset2 API function.

#### **4.3.10 Routine: Trans1Outlet**

This routine is quite simple and in creates a trans1 outlet plane at the same location as the die inlet plane and it creates a new sketch called Trans1 outlet profile. However, since the outlet profile of the transition 1 plate will be the same as the inlet profile of the die, thus this routine will copy the segments of the die inlet profile into the trans1 outlet profile. Since our die inlet profile could contain construction lines due to presence of lead-in, these segments might not get copied correctly, hence we have to convert them to regular segments and after copying we can make them construction lines again.

#### **4.3.11 Routine: TransPlateNo**

This routine will check the number of transition plates that were determined in the main extrusion tooling design form and accordingly create planes for the transition inlet and

adapter inlet and outlet. If there is only a single plate, it will create the transition inlet at the same thickness of the transition zone thickness calculated in the main GUI from the transition outlet and also create the adapter outlet plane which will be located at the same position as the transition inlet and the adapter inlet plane will be created at a distance of adapter plate thickness obtained from the designer in the main extrusion tooling design form.

If there are two transition plates, the total transition zone thickness will be divided by two and two sets of transition plates will be generated accordingly. To make the coding easier, the numbering given to transition plates will be inverse of what is actually desired. Transition 1 plate will be next to the die plate followed by transition 2 plate and then the adapter plate. However, at the end of the modeling phase, the names of the transition plates will be inverted so that transition 2 plate will lie next to the die plate followed by transition 1 and then the adapter plate.

#### **4.3.12 Routine: AdapInlet and AdapOutlet**

This routine will now create the inlet and outlet profiles of the adapter plate. The inlet profile of the adapter plate will be a simple circle made with the same diameter as the extruder breaker plate diameter and will be created on a sketch called adap inlet profile on the adapter inlet plane.

The adapter outlet profile will either be a generic shape or a custom offset of the trans1 outlet profile depending on the choice of the designer. The list of generic shapes used are explained in section 3.2.3. The adapoutlet routine begins with obtaining the dimensions of the trans1 outlet profile, the length and the height. Also, it will check the

largest of the two dimensions and also store that in memory. An upper limit to both the dimensions will be established so that the largest dimension of the generic shape will not exceed the breaker plate diameter. If the generic shape is chosen to be a simple round, a circle will be created with the largest dimension of the trans1 outlet profile and a tolerance value of 0.15 in per side. If the generic shape is chosen to be a rectangle, then a corner rectangle will be created and fillets will be added on all the four sides of the corner. If hourglass was the chosen generic shape, then four circles will be generated in such a way that they are lying tangent to each other and just the outer chords of the four circles will be trimmed to obtain the hourglass shape. If the designer selects the slot shape then CreateSketchSlot() API function will be used to generate a simple slot at the desired location.

#### **4.3.13 Routine: Trans2Inlet and Trans2Outlet**

These routines are only executed when the number of transition plates have been determined to be more than 1. In this case, the trans2 inlet profile will be the same as the adapter outlet profile or in other words, it will be the same generic shape that we have created on the adapter outlet profile. The sketch can be directly copied on to the trans2 inlet profile using convert entities method.

The trans2outlet routine will have an intermediary profile that will be the offset of the die lead-in profile as explained in Figure 3.58 and the formula will be used to determine the value of the offset. Once the value is determined, the lead-in profile will be copied on to the trans2 outlet profile sketch and will be offset using the determined value. The offset is done such a way that the base geometry gets converted to construction lines after offset

which makes it easier to remove the copied lead-in profile and be left with our desired transition 2 outlet profile on the trans2 outlet plane.

#### **4.3.14 Routine: Trans1Inlet**

This routine will behave differently depending on the number of transition plates. If there is only a single transition plate, the trans1 inlet profile will be the same as the adapter outlet profile. However, if there are two transition plates then the trans1 inlet profile will be the same as the trans2 outlet profile. Now that we have all the inlet and outlet profiles of every plate, we will rename the transition1 profiles to transition2 and vice versa, this is done so as to maintain the standards set by NJPT where the transition1 plate is considered as the plate attached to the adapter plate and transition2 plate will be the plate attached to the die plate.

#### **4.3.15 Routine: DieBlank, TransBlank and AdapBlank**

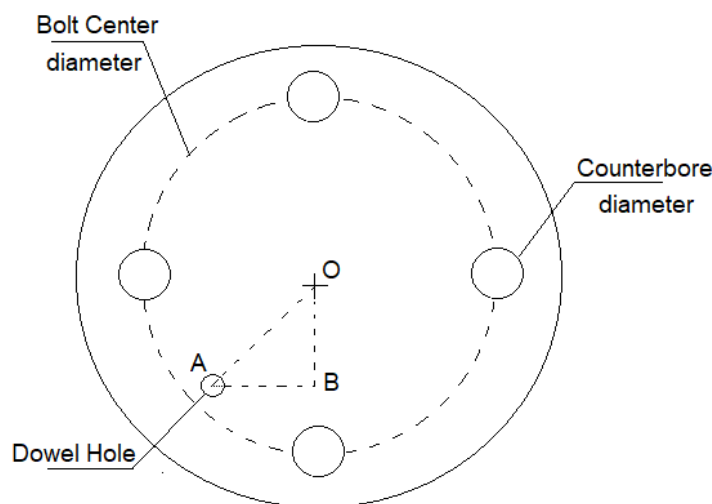
Depending on the shape of the blank the DieBlank routine will create either a circle or a rectangle such that its center will be at the origin. If the blank shape is decided to be round, then the diameter of the blank will depend on the overall dimension of the profile and a certain value for factor of safety to account for the screw holes and dowel holes. In case of rectangular plate, the overall length and height will be individually used to determine the dimensions of the rectangular blank.

The shape and dimensions of the transition plate will be the same as the shape and dimensions calculated for the die plate. If there are two transition plates, the transition blank will be created on the trans1 outlet plane as well as the trans2 outlet plane.

The AdapBlank routine will always create a round shaped blank since the adapter plate will always be round. The diameter of the adapter plate will again be a factor of the overall dimension of the profile and a factor of safety will be considered to account for the screw hole and dowel hole dimensions. The blank dimensions will be created as annotations so that it can be directly exported on to the drawing sheet.

#### 4.3.16 Routine: DowelH

This routine starts by making a connection to the knowledge base and retrieves the corresponding values for tap fit and slip fit dowel diameters based on the selection of size made by the designer in the main extrusion tooling design form. Depending on the blank shape, the dowel holes will be placed according to the constraints listed in the design protocol. The position location for dowel holes on round plates are found as seen in Figure 4.22.



**Figure 4.22** Locating dowel hole position for round blanks.

Source: New Jersey Precision Technologies

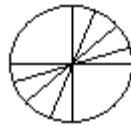
$$OA = \frac{\text{Bolt center diameter} - \text{Counterbore hole diameter}}{2} - (1.5 \times \text{Dowel diameter}) \quad (4.14)$$

$$OB = \text{Extruder output radius} + \text{Breaker clearance} \quad (4.15)$$

We can calculate the value of AB using Pythagoras theorem,

$$AB = \sqrt{OA^2 - OB^2} \quad (4.16)$$

Using the calculated values, we can determine the position of the dowel hole. The second dowel holes will lie diagonally opposite to the first hole. At NJPT the dowel holes follow a particular pattern as seen in Figure 4.23. The program will draw a circle depicting the dowel hole and then draw lines passing through the center of the dowel hole at 0, 22.5, 45, 67.5 and 90 degrees.



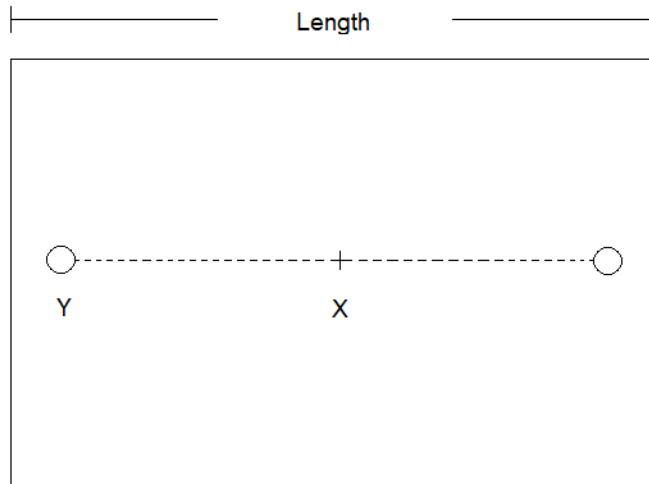
**Figure 4.23** Dowel hole pattern followed by NJPT.

Source: New Jersey Precision Technologies

In the case of rectangular blanks, the dowel holes will be positioned in such a way that they will lie on the sides of the plate as shown in Figure 4.24 and their position values will be calculated using the following formula,

$$XY = \frac{\text{Plate length}}{2} - \text{Factor of safety} \quad (4.17)$$

The value for factor of safety is assumed to be 0.5 inches so that it will have enough space to account for the common dowel sizes used at NJPT.



**Figure 4.24** Locating dowel hole position for rectangular blanks.

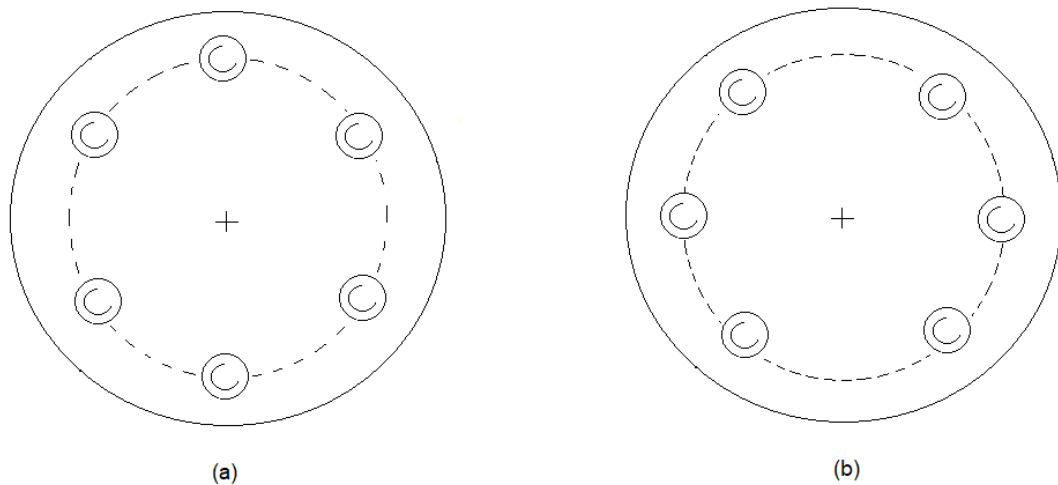
Source: New Jersey Precision Technologies

The transition plate and the die plate will have the same calculated locations for the dowels since their blank shapes will always be the same with respect to each other. However, since the adapter plate will always be round, the dowel holes that are used to connect the transition plate to the adapter plate will follow the constraints of a round pattern.

#### **4.3.17 Routine: AdapHoles, TransHoles and DieHoles**

This routine will execute only if the designer has enabled the creation of adapter holes in the main extrusion tooling design form GUI. Additionally, if the designer opts to import an existing adapter hole pattern, the routine will import the dxf file using ImportDwgOrDxfFile2 method in SolidWorks API. The imported dxf hole pattern will be pasted on a new sketch called Adap Holes on the Adap Outlet Plane.

If the designer does not import an existing hole pattern then, the routine will proceed to create screw holes of drill and tap type in a standard format as seen in Figure 4.25(a). The number of holes will be obtained from the main extrusion tooling GUI which was calculated depending on the blank diameter of the adapter plate. Annotation will be added to the hole following the format used by NJPT.



**Figure 4.25** (a)Standard hole pattern found on an adapter plate, (b) Non-standard hole pattern on adapter plate.

Source: New Jersey Precision Technologies

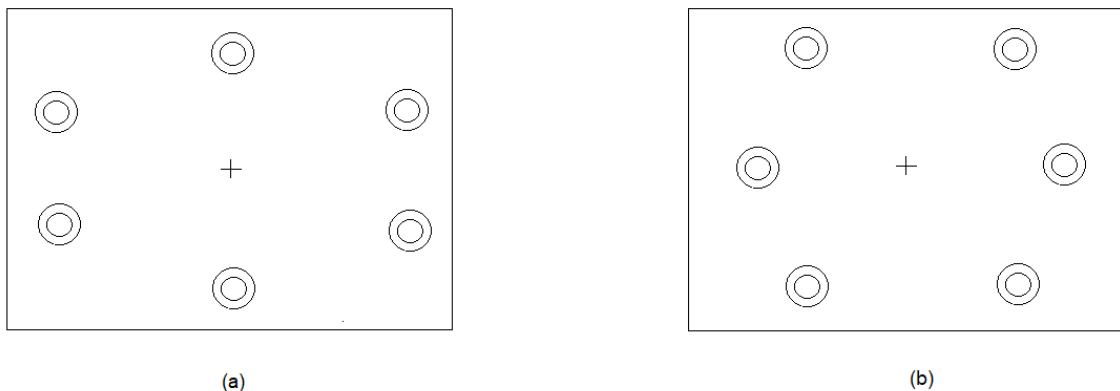
Currently in this version of the program, only supported hole patterns are the standard hole pattern and the non-standard hole patter with an offset first hole location. A custom hole pattern can be imported into the sketch but will not aid in screw hole recognition by the TransHoles routine.

The TransHoles routine will execute only if the designer has enabled creation of holes on the transition plate. The hole generation for the transition plate will depend on the location of drill and tap holes on the adapter plate and also the number of transition plates required for the particular extrusion tooling project. This routine also provides the



functionality to the designers for importing a custom hole pattern for the transition plate and it works using the same API function used for importing custom hole pattern for the adapter plate.

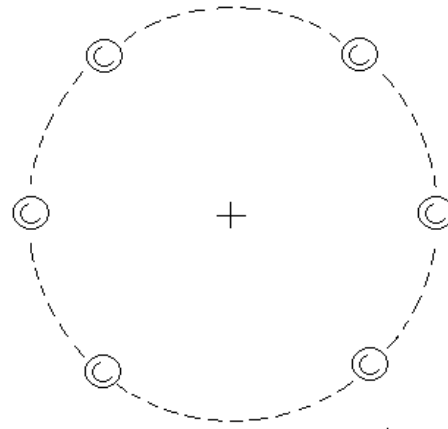
The routine begins by extracting the diametrical information for all the types of holes based on the selection made in the main extrusion tooling design form namely the counterbore, clearance, drill and tap diameters. For the program to recognize the hole pattern on the adapter plate and this is achieved by collecting all the locations of holes found in the adapter plate into an array and testing if any of the centers are located in the positive y axis with its x coordinate value as 0. Depending on the type of hole pattern used in adapter plate, the number of transition plates and the shape of the blank, holes will be generated on the transition plate. The routine DieHoles will check for DR and TP holes located on the transition plate and create CB and CL holes at the same locations. For rectangular plates, there can be two types of hole arrangement as shown in Figure 4.26, either an odd arrangement where the number of holes along the length of the plate is odd or an even arrangement where the number of holes along the length of the plate is even.



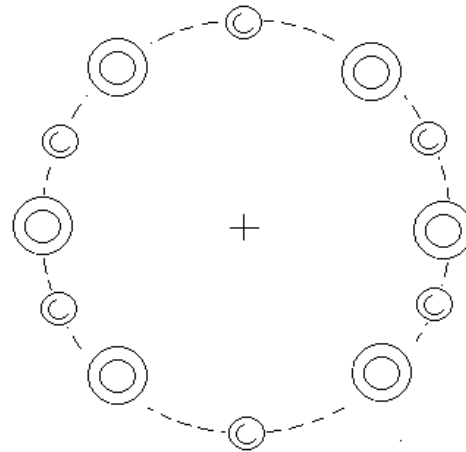
**Figure 4.26** (a) Odd arrangement of holes for rectangular plates, (b) Even arrangement of holes for rectangular plates.

Source: New Jersey Precision Technologies

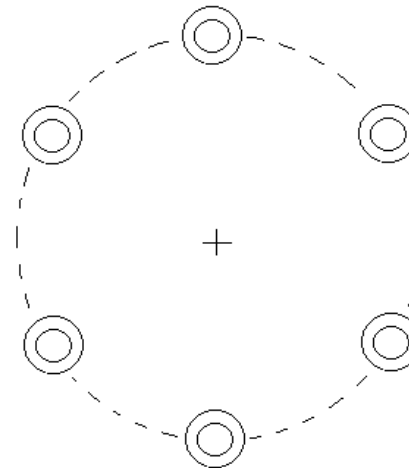
Adapter  
Non-standard DR and TP



Transition 1  
CB and CL at same location of DR  
and TP in Adapter plate  
DR and TP lies between CB and CL



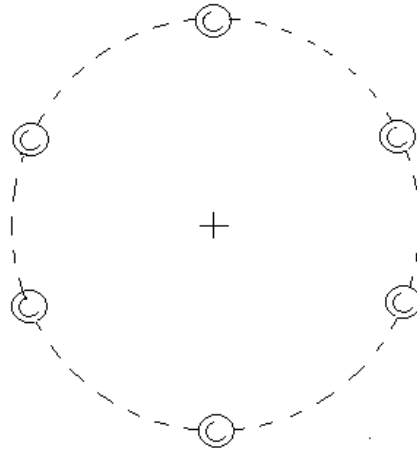
Die Plate  
CB and CL at same location of DR  
and TP in Trans1 plate



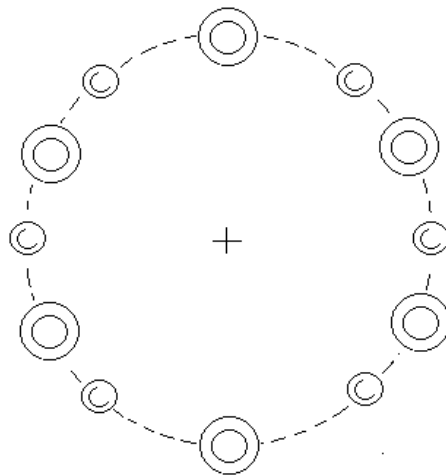
**Figure 4.27** Hole pattern arrangement for adapter, transition1 and die plates for a single round transition plate and non-standard adapter hole pattern case.

Source: New Jersey Precision Technologies

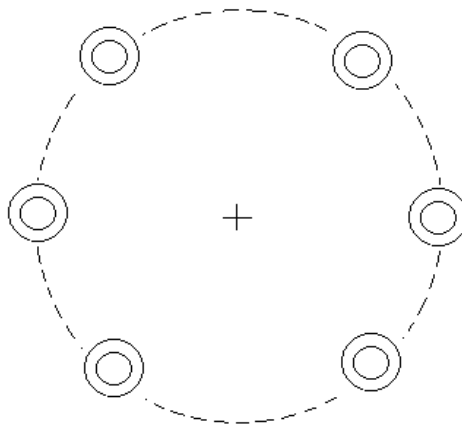
Adapter  
Standard DR and TP pattern



Transition 1  
CB and CL at same location of DR  
and TP in Adapter plate  
DR and TP lies between CB and CL

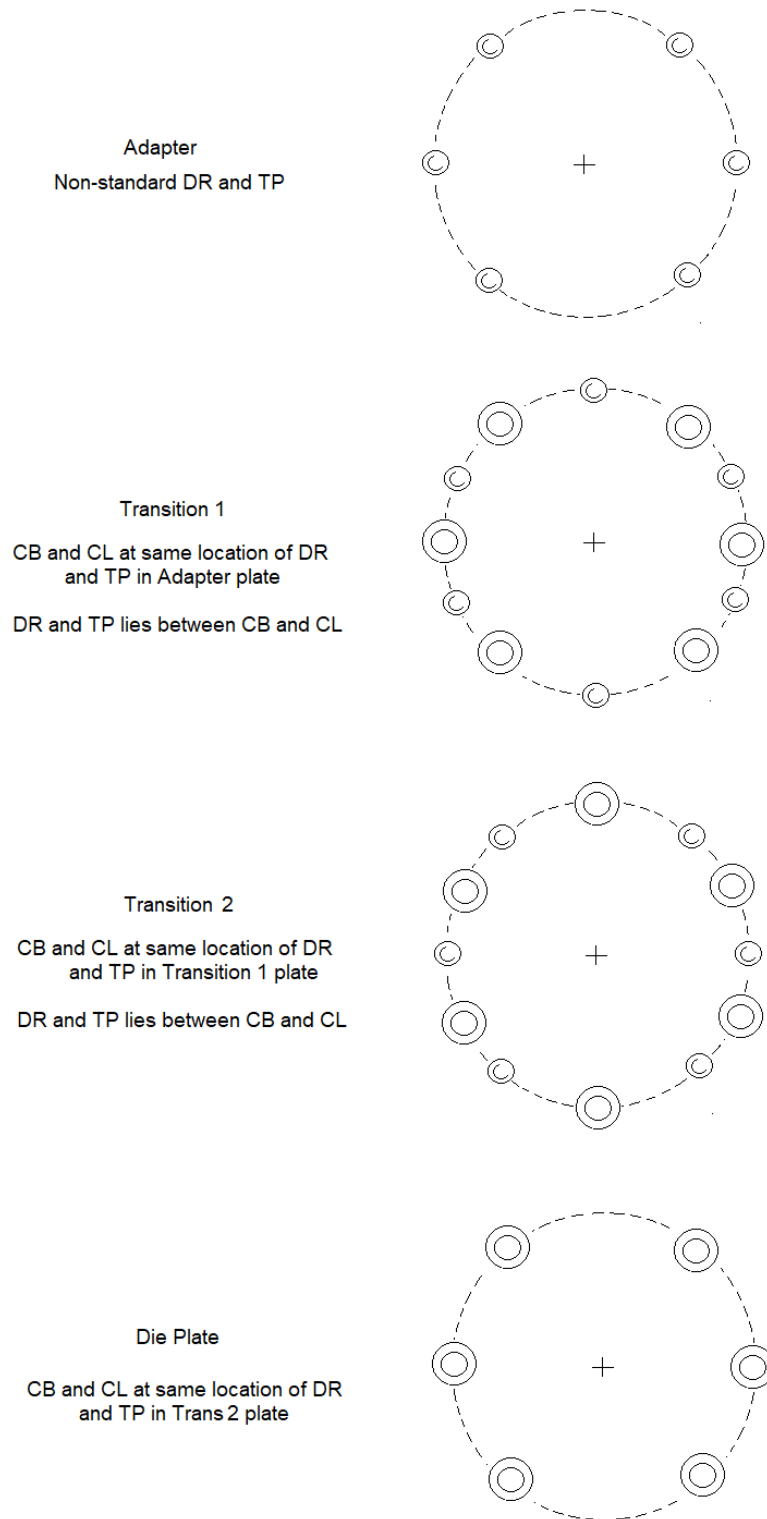


Die Plate  
CB and CL at same location of DR  
and TP in Trans1 plate



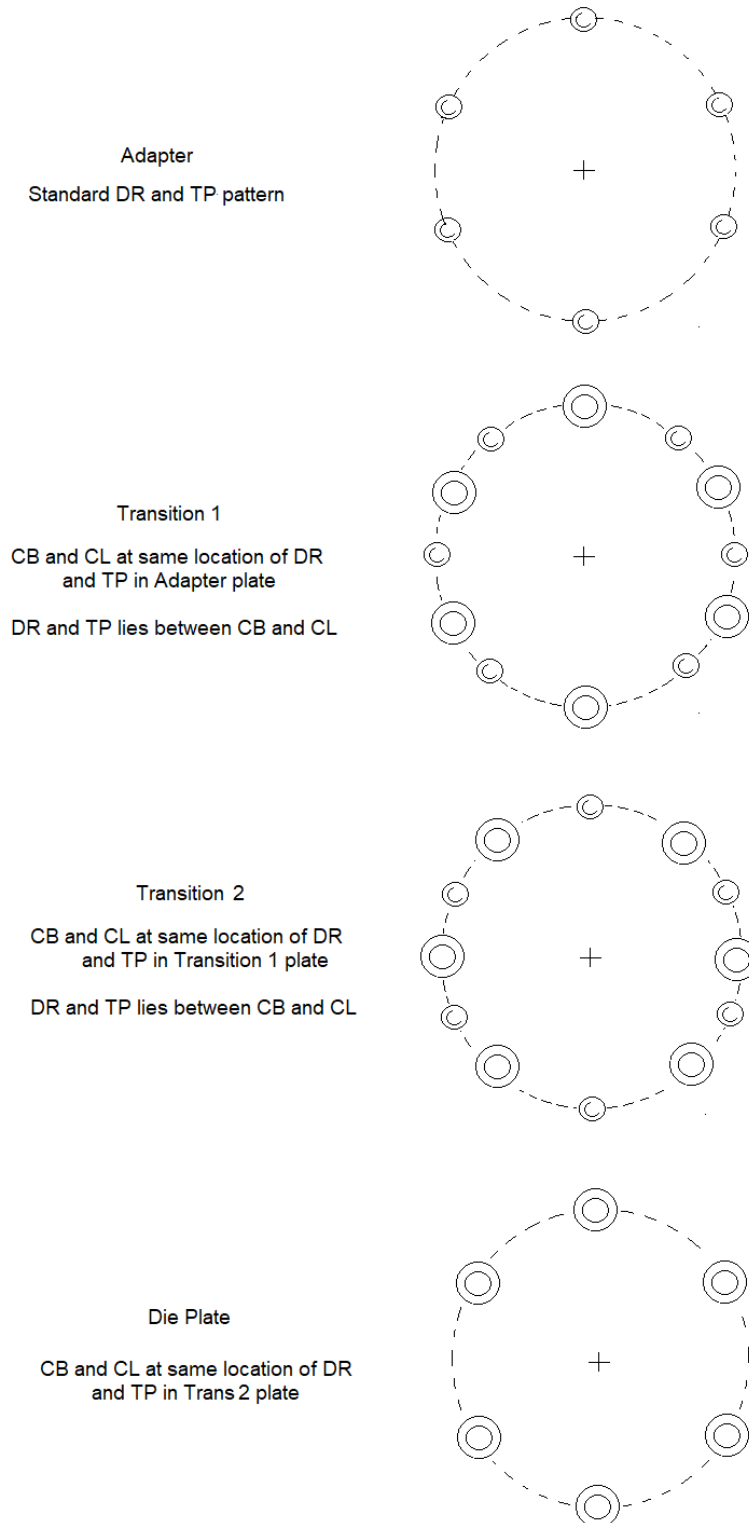
**Figure 4.28** Hole pattern arrangement for adapter, transition1 and die plates for a single round transition plate and standard adapter hole pattern case.

Source: New Jersey Precision Technologies



**Figure 4.29** Hole pattern arrangement for adapter, transition1, transition2 and die plates for double round transition plates and non-standard adapter hole pattern case.

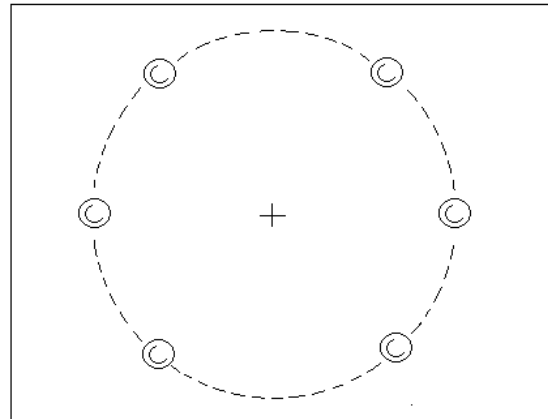
Source: New Jersey Precision Technologies



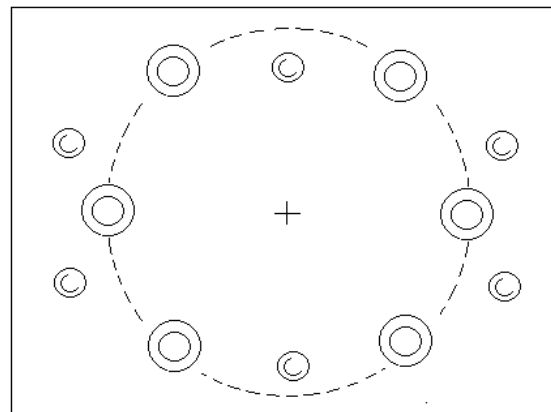
**Figure 4.30** Hole pattern arrangement for adapter, transition1, transition2 and die plates for a double round transition plates and standard adapter hole pattern case.

Source: New Jersey Precision Technologies

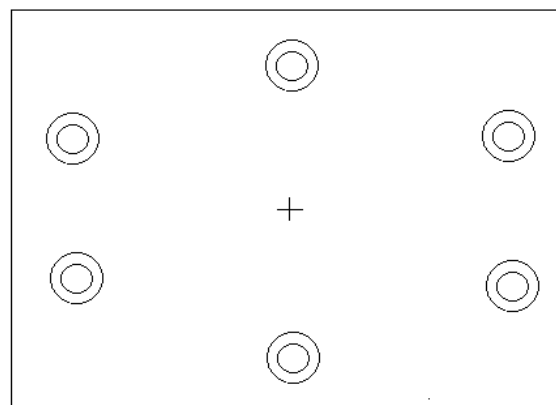
Adapter  
Non-standard DR and TP



Transition 1  
CB and CL at same location of DR  
and TP in Adapter plate  
DR and TP will be made in the odd format



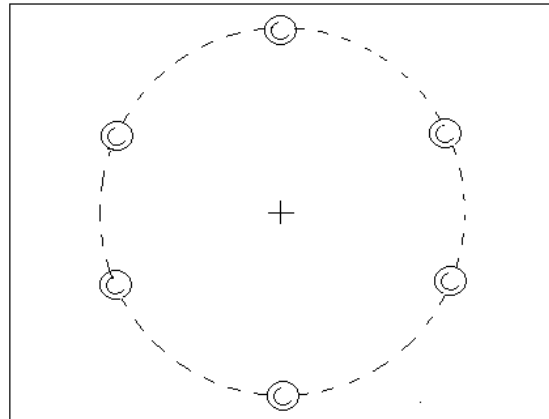
Die Plate  
CB and CL at same location of DR  
and TP in Trans1 plate



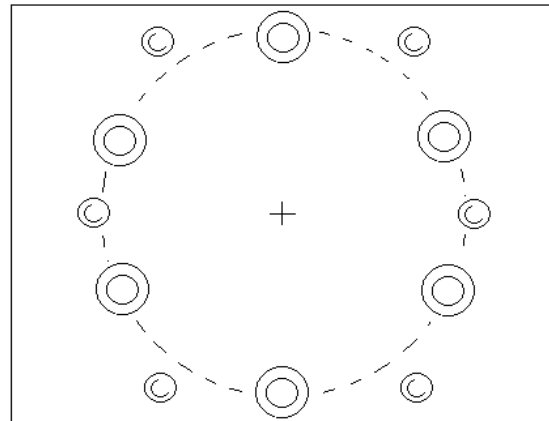
**Figure 4.31** Hole pattern arrangement for adapter, transition1 and die plates for a single rectangular transition plate and non-standard adapter hole pattern case.

Source: New Jersey Precision Technologies

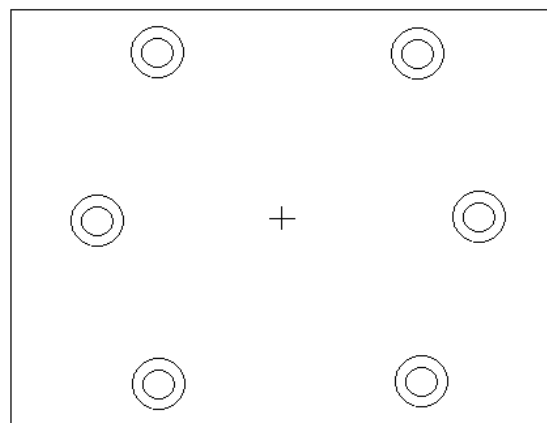
Adapter  
Non-standard DR and TP



Transition 1  
CB and CL at same location of DR  
and TP in Adapter plate  
DR and TP will be made in the even format

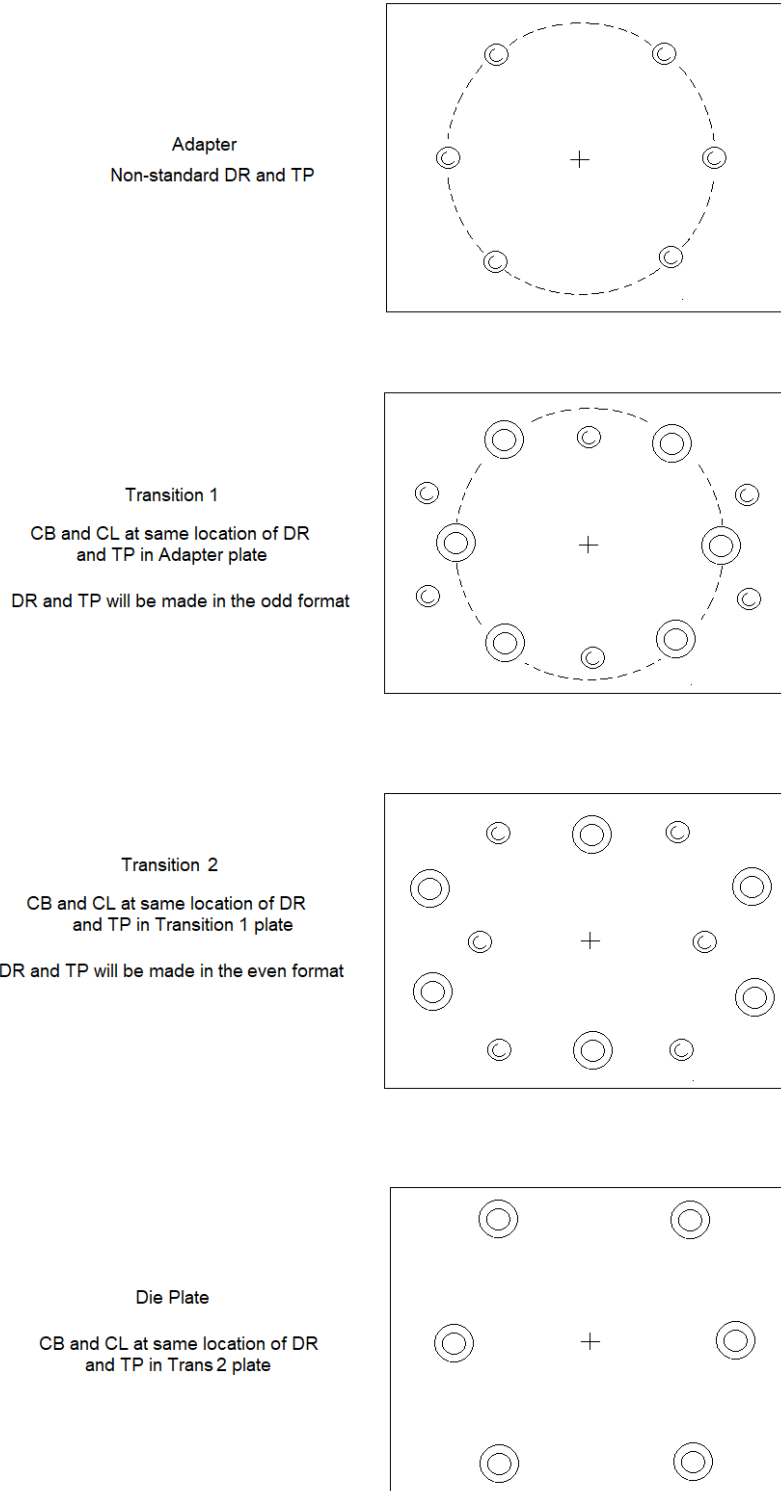


Die Plate  
CB and CL at same location of DR  
and TP in Trans1 plate



**Figure 4.32** Hole pattern arrangement for adapter, transition1 and die plates for a single rectangular transition plate and standard adapter hole pattern case.

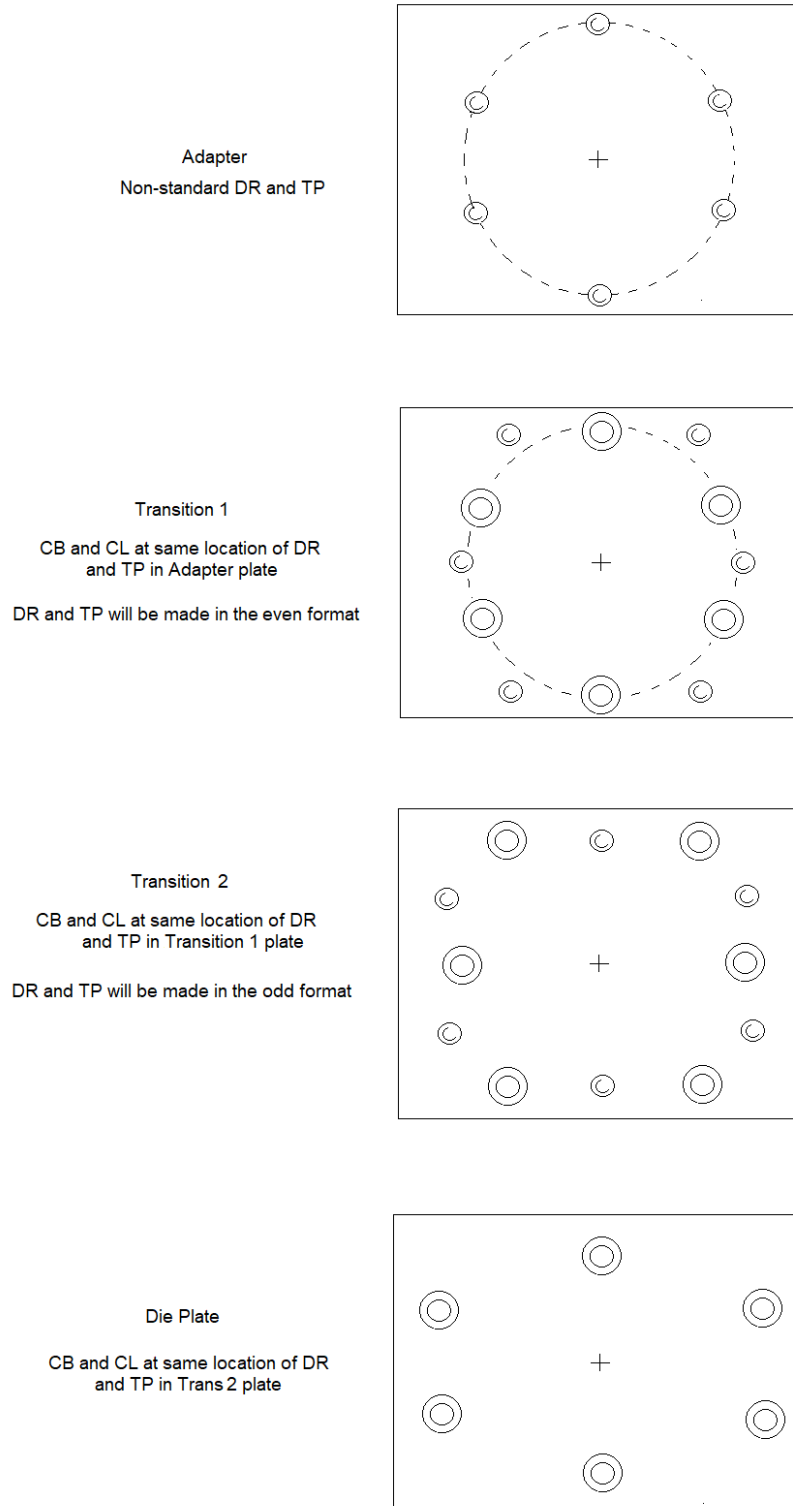
Source: New Jersey Precision Technologies



**Figure 4.33** Hole pattern arrangement for adapter, transition1, transition2 and die plates for double rectangular transition plates and non-standard adapter hole pattern case.

Source: New Jersey Precision Technologies





**Figure 4.34** Hole pattern arrangement for adapter, transition1, transition2 and die plates for double rectangular transition plates and standard adapter hole pattern case.

Source: New Jersey Precision Technologies

#### **4.3.18 Routine: DwgPrep, DwgDie, DwgTrans and DwgAdap**

This routine executes after all the holes have been designed and the next step is to prepare the model for exporting into drawing sheets. Dimensions are added to the adapter, transition and die plates for both round and rectangular plates using the AddDimension2() API function. Dimensions are also added to all the designed screw holes in the same format as the one used at NJPT.

Since the design is created as two-dimensional sketches, for the drawing sheet to represent the bottom view, sketches have to be generated to represent the thickness of the plate. Using the thickness values for each plate calculated in the main design extrusion design GUI, simple rectangles are created with its length and height corresponding to the diameter in the case of round plates and the dimensions of the rectangular plate.

The routine proceeds to calculate the perimeter of all the outlet profiles of each plate since it is an entry in the title block of the drawing sheet. The perimeter is calculated by editing the respective sketch and iterating through all the sketch entities while adding their length and the total sum will give the perimeter of the profile.

Finally, the model is ready to be exported to the drawing sheet but before the export the model is saved as an SLDPRT file in the same directory that the customer product file was uploaded from. At this point the DwgDie starts executing which initiates by importing the NJPT drawing template, as seen in Figure 4.35, that was provided in the ExtToolMain routine. There are two common sizes of drawing sheets used at NJPT, a custom A size having 8.5 x 11 inches and a custom B size having 17 x 11 inches dimensions; and their corresponding title blocks are 1 inch shorter in both length and height. The size and scale of the drawing sheet is automatically determined based on the dimensions of the blank plate

determined from the main extrusion tooling design GUI. There will be two views for each drawing sheet, a front view and a bottom view and will be drawn following the principle of third angle projection. The routine will now go through all the text entries in the drawing sheet and look for the title block entries. It will assign corresponding values stored in memory for all the title block elements are update them in the drawing sheet.

Part No.	JAC #	Revision Notes	DATE	SIGNATURE	TABLE
<p>NOTES:</p> <p>A) USE UV PROGRAM</p> <p>B) PROGRAM WILL ROUGH AND J SKIN</p> <p>C) MAX CHRE ANGLE =</p> <p style="text-align: right;">ALL PROFILE DIM TO BE HELD TO ± .001</p> <p>XXXXXXXXXX SP SPHERS UNLESS OTHERWISE NOTED TOLERANCES UNLESS OTHERWISE NOTED XX = 0.000, XXX = 0.000, XXXX = 0.0000 FRACTIONS = 1/16", DECIMALS = .001"</p> <p style="text-align: right;">NEW JERSEY PRECISION TECHNOLOGIES, INC. J-800-409-3000</p>					
PERIMETER:		SCALE: 1:1		DRN:	CHK:
TITLE:		DATE:	DATE:		
CUSTOMER CODE:	JOB NO.:	DET NO.:	REQD: J		
HAT-L:	HDN.: RC.	DIE SET: 1	TOL-CODE A		
LEVEL:	CHNL: 0.0000	W P H:	EDM H:	DB FMT: 2	

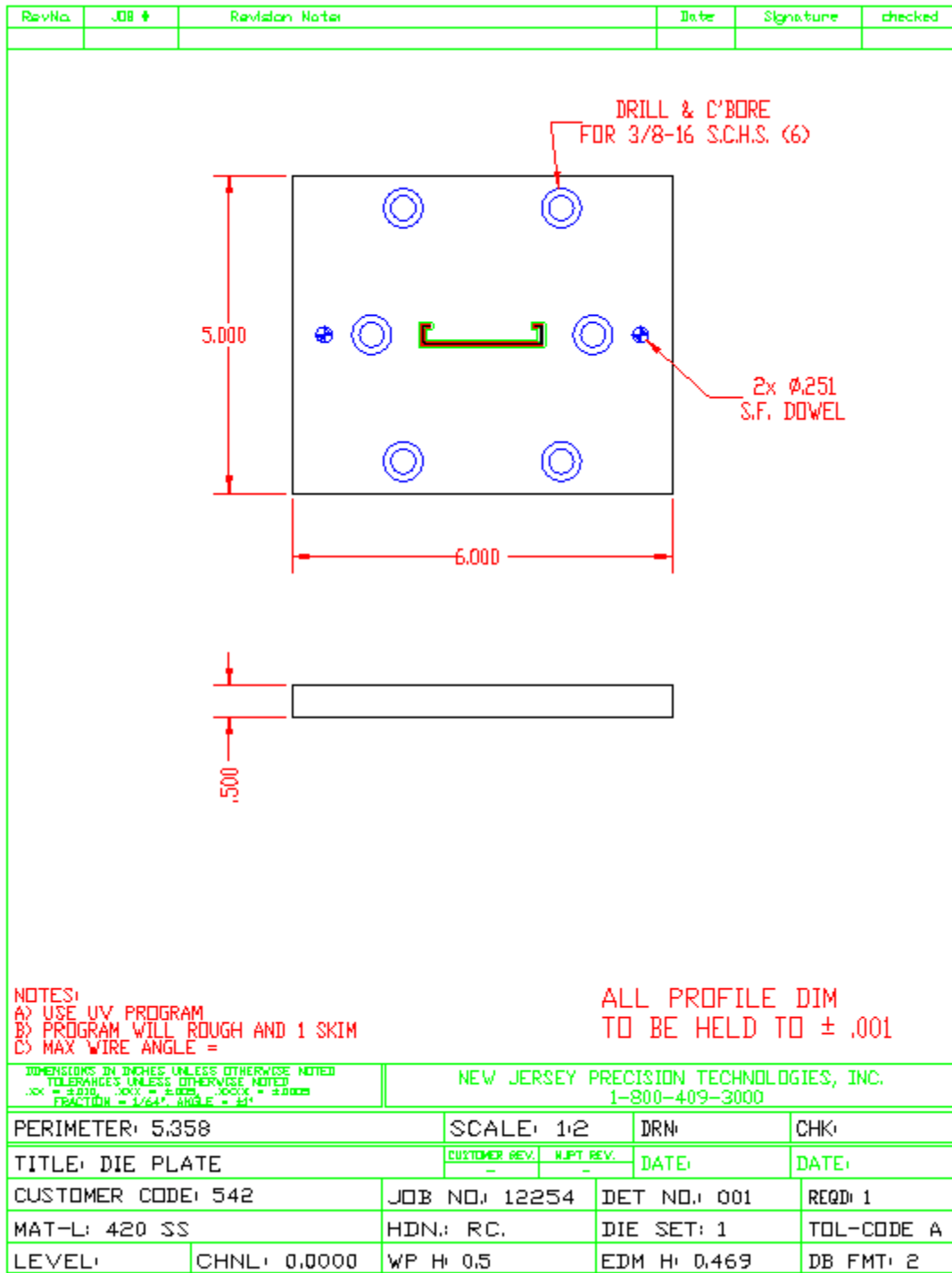
**Figure 4.35** Custom A size drawing template with proper layers assigned used at NJPT.

Source: New Jersey Precision Technologies

Since our drawing profiles and elements have to be in particular layer numbers and because SolidWorks does not directly allow individual features from an imported model file to be assigned to individual layers, we have to select each profile separately, preassign the layer of the sheet it will currently be in and then convert the selected profile entities. This method will create sketch entities that belong to our pre-assigned layer on the drawing sheet and will also take on the line color assigned to that particular layer. Once the entities have been converted, the selected sketch will be hidden so that only the converted entities in the proper layer with its proper color will be visible. This is repeated for the inlet and outlet profiles of the die plate as well as the screw and the dowel holes. A drawing sheet for the die plate with all its profiles in the correct layers and updated title block information can be seen in Figure 4.36.

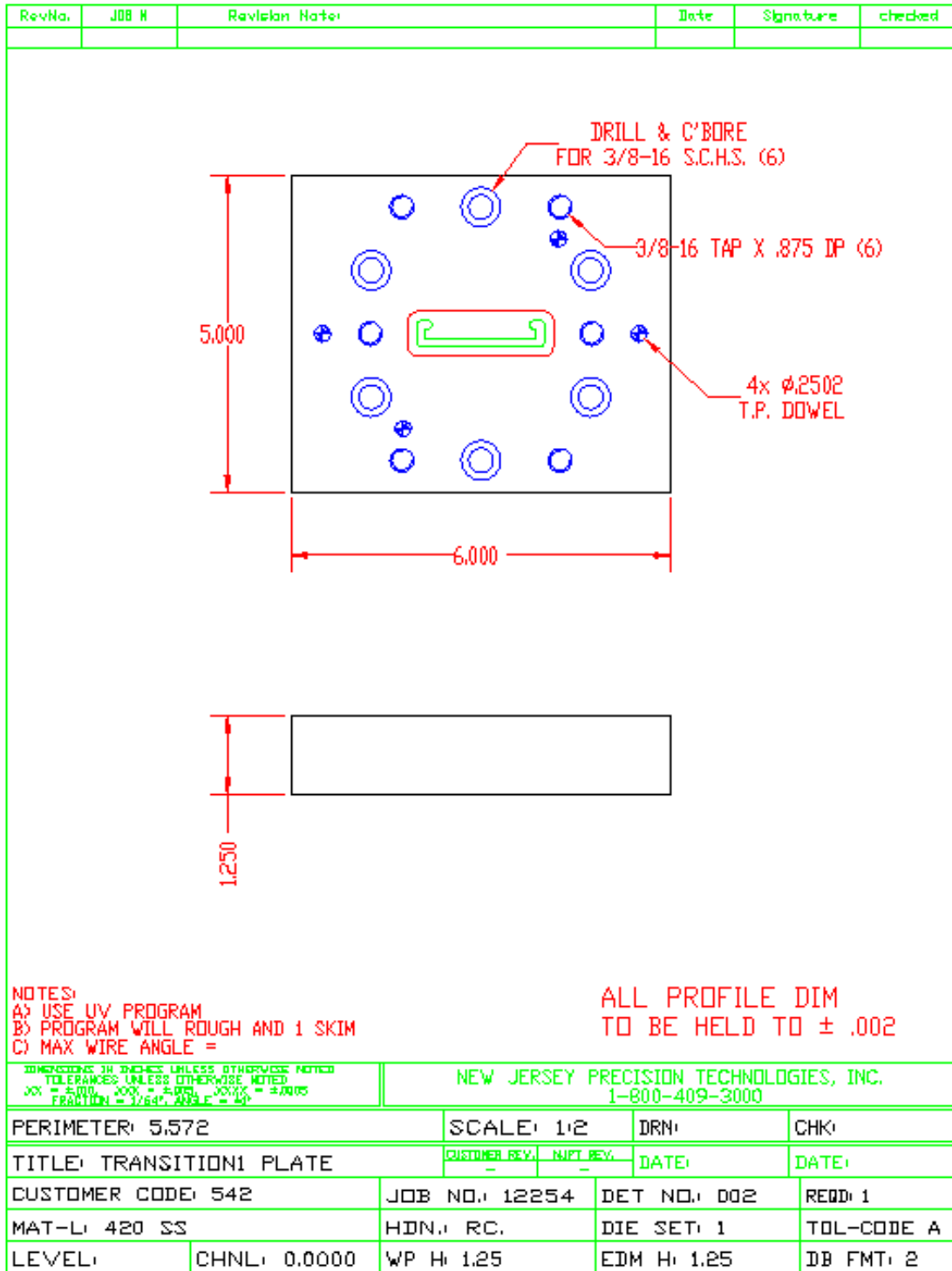
Two routines were created to create drawing sheets for the transition plates. DwgTrans creates the drawing sheet for the first transition plate and DwgTrans2 is used and only executed to create the drawing sheet for the second transition plate when the design requires it. Figure 4.37 shows the drawing sheet generated for the transition plate for the extrusion profile in Figure 3.1,

DwgAdap similar to the other drawing routines, will create a new sheet named Adapter Plate as shown in Figure 4.37, and will import all the features like inlet and outlet profiles, the screw and dowel holes and their dimensions while assigning them to their respective layers. Finally, the drawing sheets are saved individually as Die Plate, Transition 1 Plate, Transition 2 Plate (Optional), Adapter Plate in DXF format. This concludes the automated design process and the desired outputs have been achieved.



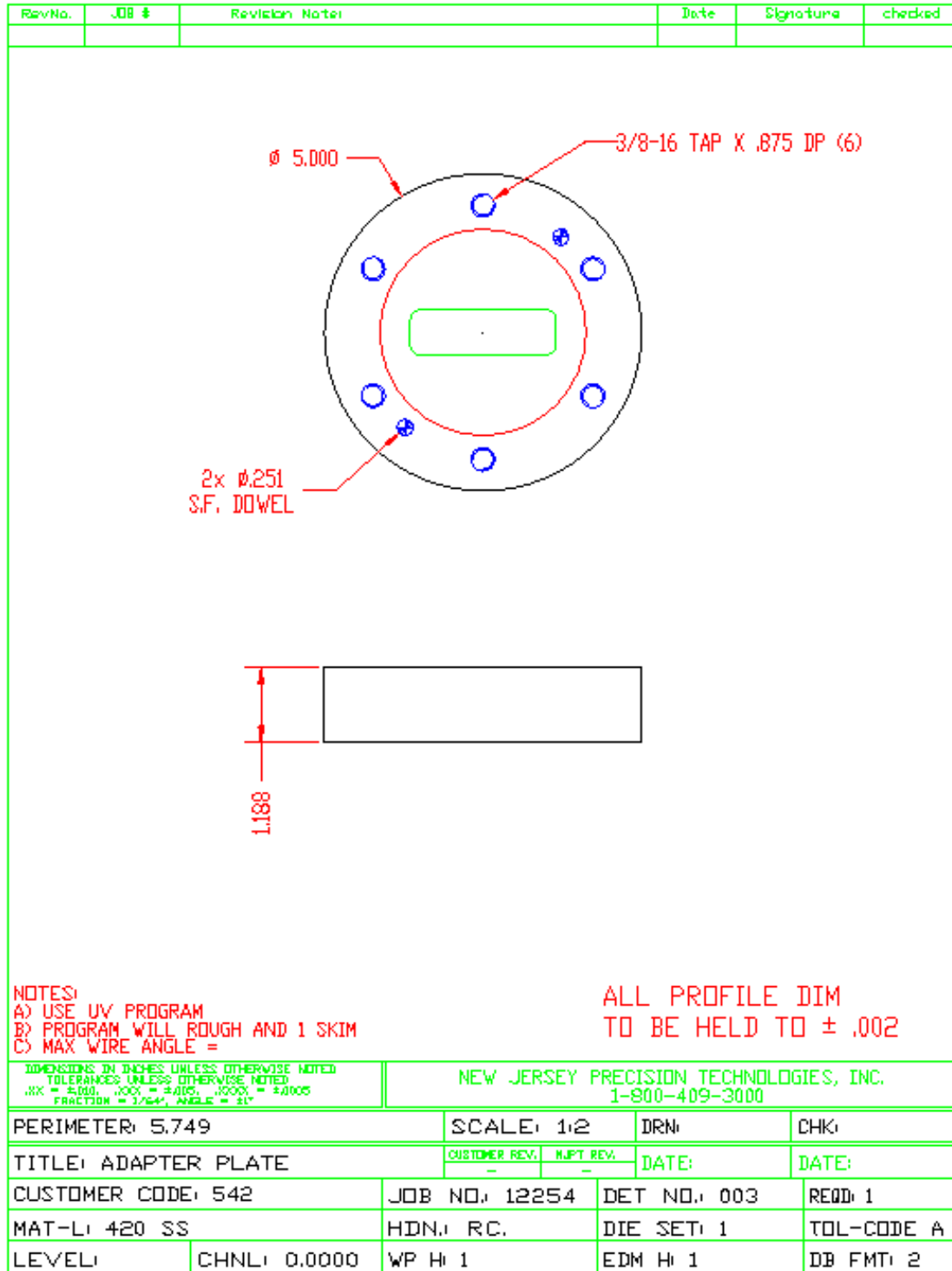
**Figure 4.36** Drawing sheet depicting die plate with proper layers assigned used at NJPT.

Source: New Jersey Precision Technologies



**Figure 4.37** Drawing sheet depicting transition 1 plate with proper layers assigned used at NJPT.

Source: New Jersey Precision Technologies



**Figure 4.38** Drawing sheet depicting adapter plate with proper layers assigned being used at NJPT.

Source: New Jersey Precision Technologies

#### 4.4 Verification and Testing



The automated extrusion tooling design program is created using Visual Basic within SolidWorks with the help of the built-in SolidWorks API that allows us to control every aspect of the program and use it to make the model and drawing sheets. Since this program deals with the geometry of the plastic extrusion profile, the only way to ensure that this program meets all its specified requirements at this current stage of development, is to let it run with a lot of test cases. To select the required test cases, the program was analyzed and all possible instances were identified based on individual routines belonging to each area, represented with their ID, as shown in Figure 4.1. The table representing this overall program analysis of all individual routines can be found in Table A.1 in Appendix A.


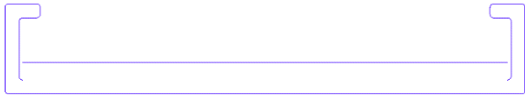

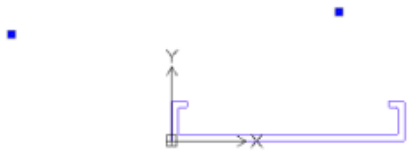
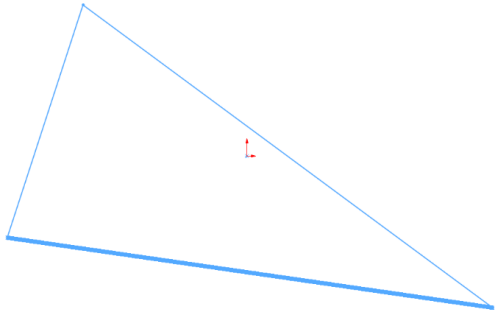

Based on the verification analysis table in Table A.1 in Appendix A, test profiles were generated to understand and verify how the program deals with the listed situations as seen in Table 4.4. Additionally, test cases were selected from extrusion tooling designs that were done manually by the engineers at NJPT and they have been listed in Table 4.5.

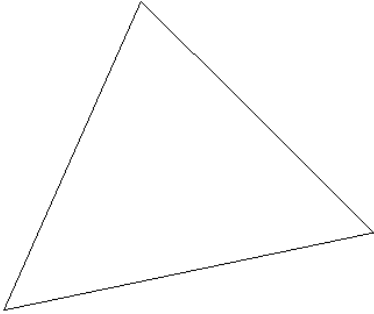
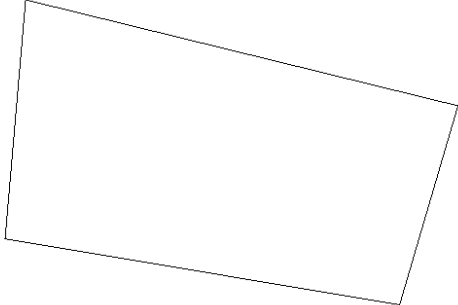
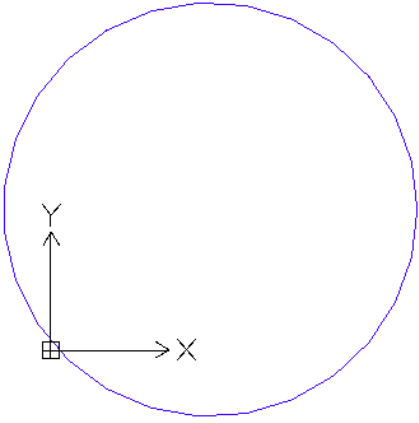
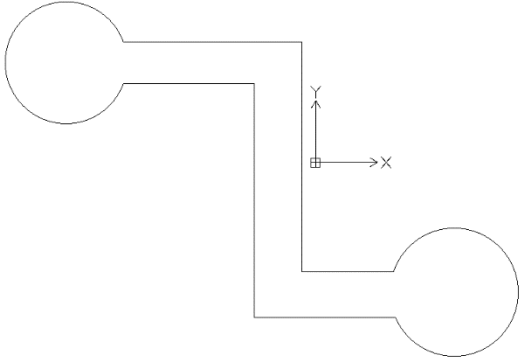
**Table 4.4** Test Cases Selected for Verification of Expert System

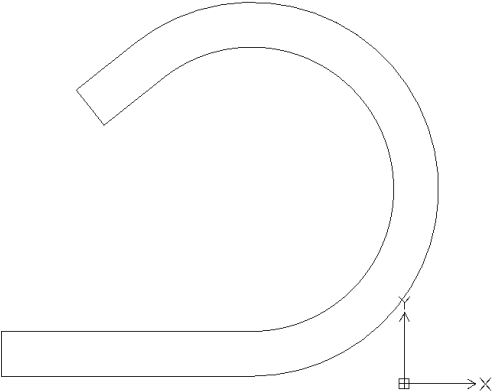
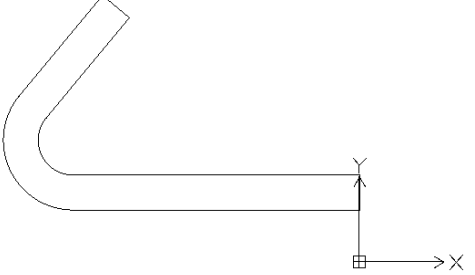
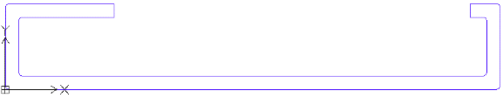
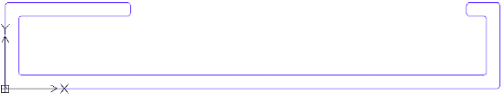
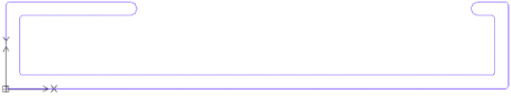

Test Case ID	Possible Instances	Test Case Description	Test Case Image
PIA1a	All referenced documents were successfully located and connections were established	All referenced documents are correctly located and the files can be accessed by the program	PERFECT CASE – All reference documents have been assigned correctly (database, info pictures and drawing templates)

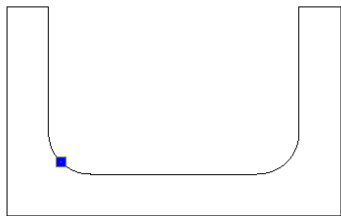


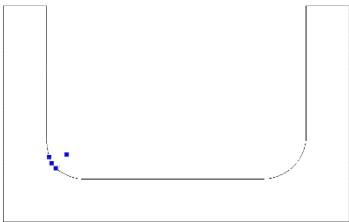
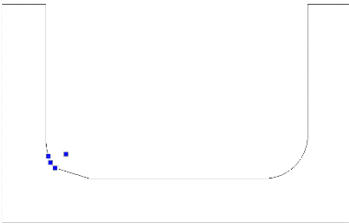
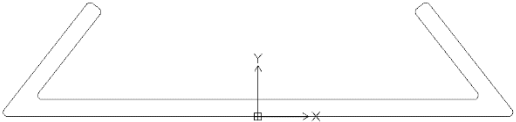
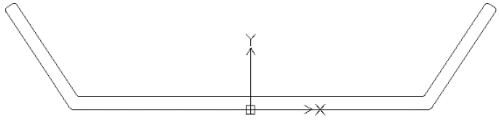


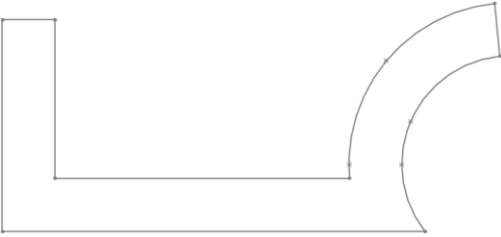

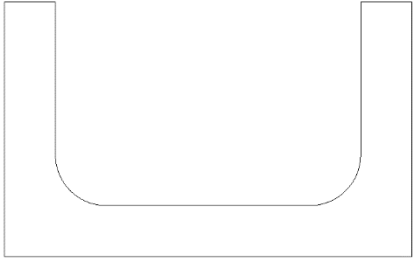
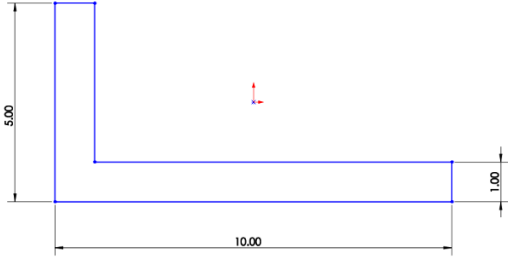
Test Case ID	Possible Instances	Test Case Description	Test Case Image
P1A1b	Excel database does not exist	Rename excel sheet or change its location. In the test case image shown, we have renamed the database to an arbitrary name	Remove database reference from program for testing
P1A1c	Info pictures will have been moved	Remove a test picture path and give it an arbitrary name as shown in the test case image to confuse the system	Remove info pictures path from program for testing
P1B2a	Empty or no file is given as product profile	Do not import a file when running the program. The test case image shows how we set up the case in which we have not imported a product profile	Run the program without importing any profile
P1B2b	A renamed file having .dxf even though it is not a DXF file	Create a text file and rename it to test.dxf as shown in the test case image	Import a text file renamed with .DXF format
P1B2c	A file with a different file format is given as input	Try to import a file with an unsupported file format. The test case image shows how we are trying to import a file with a .bak format which is not supported	Import a text file into the program
P1C3aa	The sketch has disjointed entities or gaps	2D Section produced with Gap length: 0.00005 in. File produced in Solidworks	
P1C3ab		2D Section produced with Gap length: 0.0005 in. File produced in Solidworks	

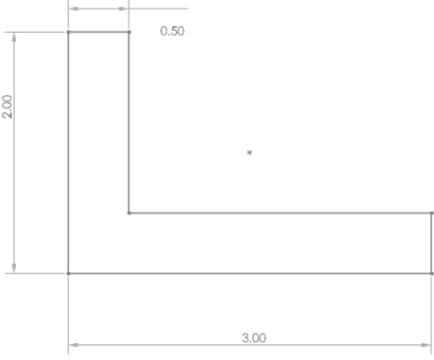
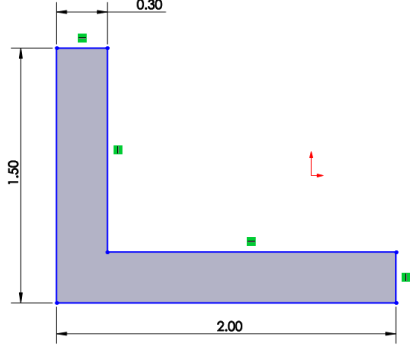
Test Case ID	Possible Instances	Test Case Description	Test Case Image
P1C3ac		2D Section produced with Gap length: 0.005 in. File produced in Solidworks	
P1C3ad		2D Section produced with Gap length: 0.05 in. File produced in Solidworks	
P1C3b	The sketch could have overlapping entities	2D Section produced with overlapping entities	
P1C3c	The sketch could have 0 length entities	DXF file created with zero length entities contained in them	
P1C3d	After analysis of historical database of jobs done at NJPT, 99% of the cases contained entities less than 2000	DXF file contains sketch made up of 2000 entities	
P1C3e	Sketch can contain entities like spline or ellipse	DXF file contains unsupported entities	

Test Case ID	Possible Instances	Test Case Description	Test Case Image
PIC4a	Sketch contains a 3-sided polygon	2D Sketch contains a 3-sided polygon	
PIC4b	Sketch contains a 4-sided polygon	2D Sketch contains a 4-sided polygon	
PIC4d	Sketch can be a simple circular profile	DXF file containing 2D circular sketch	
PIC4e	Closed sketch containing arcs and line segments	2D section sketch containing arcs and lines	

Test Case ID	Possible Instances	Test Case Description	Test Case Image
P1C5a	Sketch contains major arcs	DXF file contains 2D sketch containing major arcs	
P1C5b	Sketch contains minor arcs	DXF file contains 2D sketch containing minor arcs	
P1D6b	Profile has legs with flat ends	DXF file contains 2D profile with legs having flat ends	
P1D6c	Profile has legs with flat ends and corner radii	DXF file contains 2D profile with legs have flat ends with curved corner radii	
P1D6d	Profile has legs with a curved end	DXF file contains 2D profile with curved ends	
P1E7ba	Inner corner is a point	DXF file contains a profile whose inner corners are points lying between two lines	

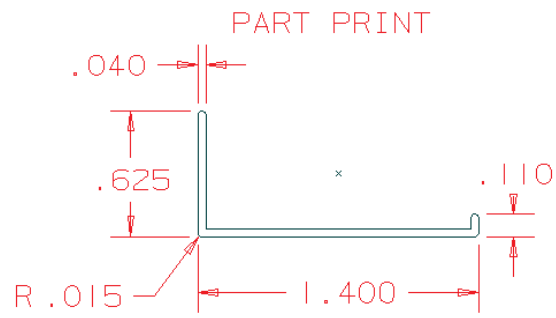
Test Case ID	Possible Instances	Test Case Description	Test Case Image
P1E7bb		DXF file contains a profile whose inner corners are points lying between two arcs	
P1E7bc		DXF file contains a profile whose inner corners are points lying between a line and an arc	
P1E7ca		DXF file contains a profile whose inner corners are radii lying between two lines	
P1E7cb	Inner corner is a radius	DXF file contains a profile whose inner corners are radii lying between two arcs	
P1E7cc		DXF file contains a profile whose inner corners are radii lying between a line and an arc	
P1E7d	The corner angle is acute	DXF file contains a profile having legs with acute corner angles	
P1E7e	The corner angle is obtuse	DXF file contains a profile having legs with obtuse corner angles	

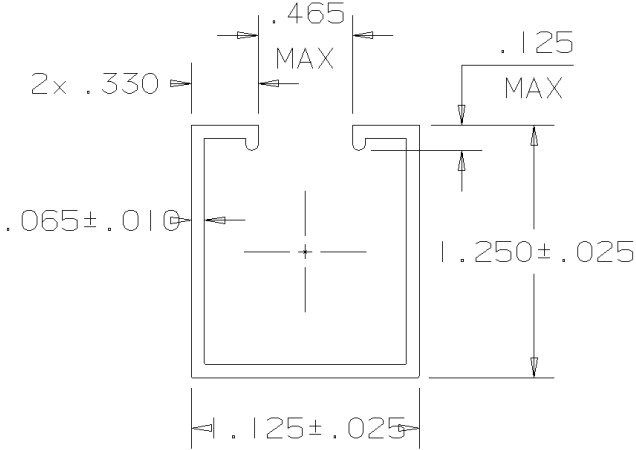
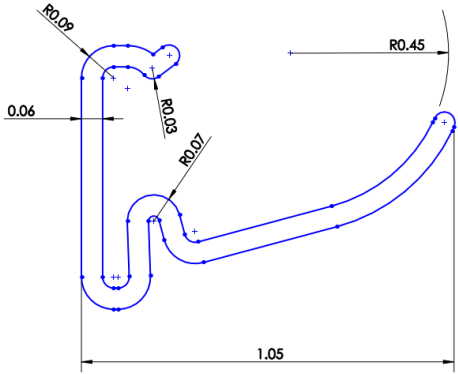
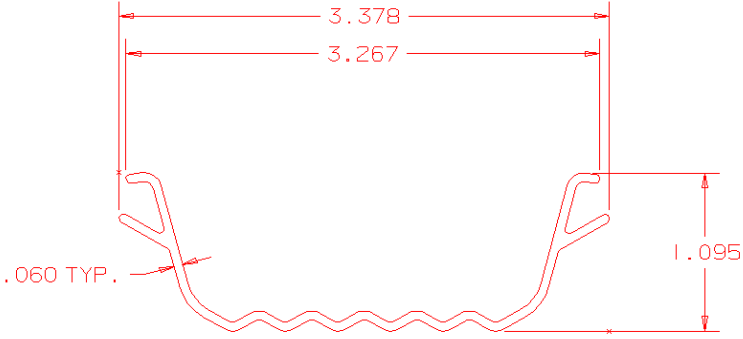
Test Case ID	Possible Instances	Test Case Description	Test Case Image
P1F8a	If geometry contains a clockwise arc between two counterclockwise segments	DXF file contains a profile having a clockwise arc between two counterclockwise segments	 <p>The diagram shows a profile consisting of a vertical segment on the left, a horizontal segment at the bottom, and a curved segment on the right. The curved segment is a clockwise arc that connects the horizontal segment to a vertical segment on the far right. Arrows on the lines indicate the direction of the profile's path.</p>
P1F8b	If the inner corner of the profile has a small radius	DXF file contains a profile having small radii at the inner corner	 <p>The diagram shows a U-shaped profile with a small, tight radius at the inner corner where the vertical and horizontal segments meet.</p>
P1F8c	If the inner corner has a large radius	DXF file contains a profile having large radii at the inner corner	 <p>The diagram shows a U-shaped profile with a large, smooth radius at the inner corner where the vertical and horizontal segments meet.</p>
P1G10a	Profile will create require more than two transition plates	If the profile is selected to have a length of 10 inches, wall thickness of 1 inch and a wire cutting angle of 25 degrees, then the transition zone thickness will be greater than 4 inches	 <p>The diagram shows an L-shaped profile with dimensions: a vertical segment of height 5.00, a horizontal segment of length 10.00, and a wall thickness of 1.00. A small red and blue coordinate system is shown near the corner.</p>

Test Case ID	Possible Instances	Test Case Description	Test Case Image
P1G10b	Profile will require two transition plates	If the profile is selected to have a length of 5 inches, wall thickness of 1 inch and a wire cutting angle of 19 degrees, the transition zone thickness will be 2.25 inches	
P1G10c	Profile will require a single transition plate	If the profile is selected to have a length of 5 inches, wall thickness of 1 inch and a wire cutting angle of 25 degrees, the transition zone thickness will be 1.5 inches	

Source: New Jersey Precision Technologies

**Table 4.5** Test Cases Selected From Real Extrusion Designs at NJPT for Verification

Test Case ID	Product Profile Image	Selection Criteria
48799		Profile has two legs with different lengths.

Test Case ID	Product Profile Image	Selection Criteria
41640	 <p>Technical drawing of a U-shaped profile. Dimensions include: 2x .330 (width of top flanges), .465 MAX (width of top flange), .125 MAX (width of top flange), .065±.010 (thickness of top flange), 1.250±.025 (height of the U-shape), and .125±.025 (width of the base).</p>	<p>U Shaped profile with curved legs which will require additional flow restrictors.</p>
45629	 <p>Technical drawing of a profile with multiple arcs and segments. Dimensions include: R0.09 (radius of top arc), 0.06 (width of top arc), R0.03 (radius of inner arc), R0.07 (radius of bottom arc), R0.45 (radius of right arc), and 1.05 (total width).</p>	<p>Contains multiple arcs and segments.</p>
46544	 <p>Technical drawing of a wide profile with four legs. Dimensions include: 3.378 (total width), 3.267 (width of top flange), .060 TYP. (thickness of top flange), and 1.095 (height of the profile).</p>	<p>Really wide profile with varying geometry and four legs.</p>



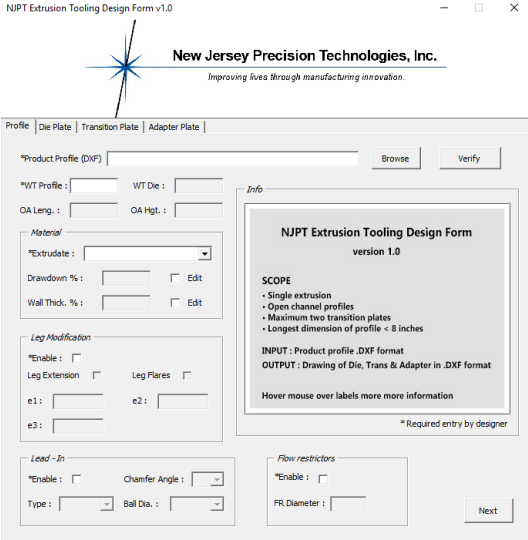
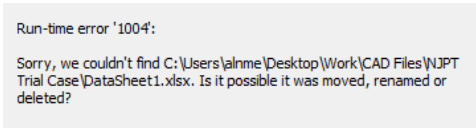
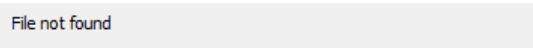
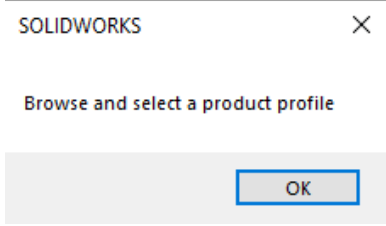
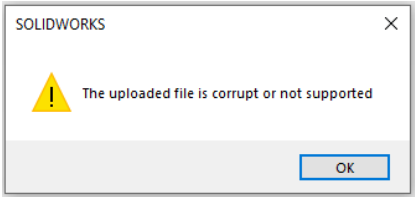
Test Case ID	Product Profile Image	Selection Criteria
48464		Very small and standard U-Shaped open channel profile.
49726		Open channel profile that has its legs pointing towards each other.

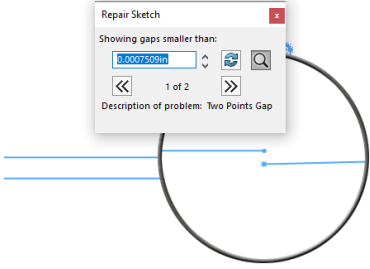
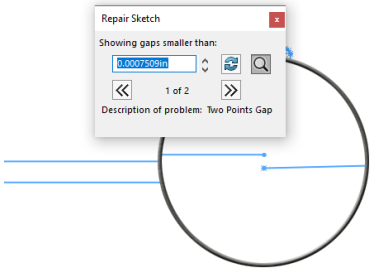
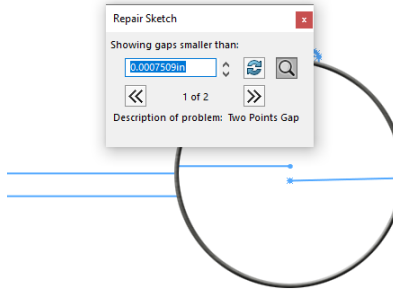
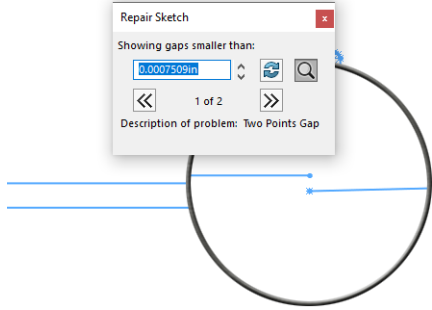
Source: New Jersey Precision Technologies

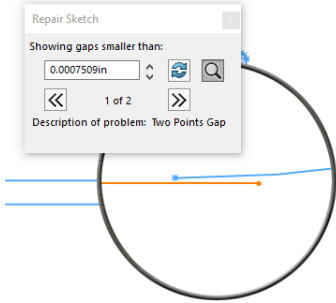

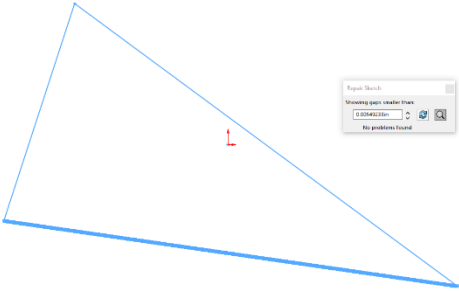
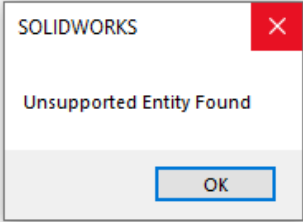
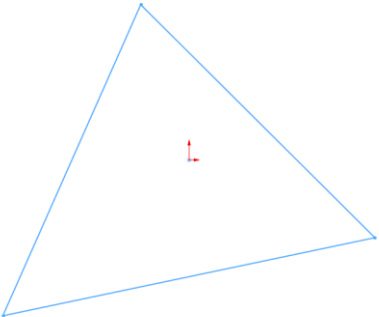
#### 4.4.1 Results

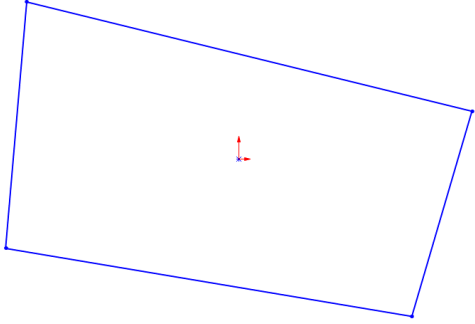
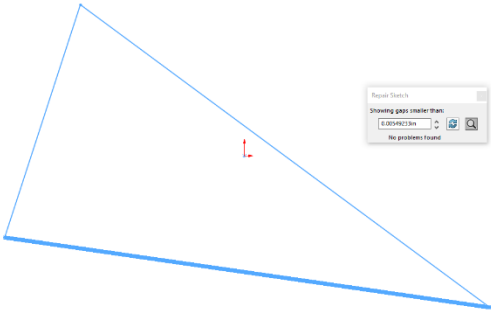
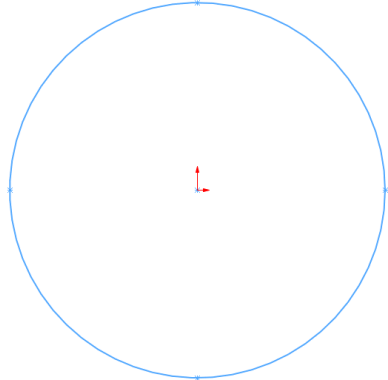
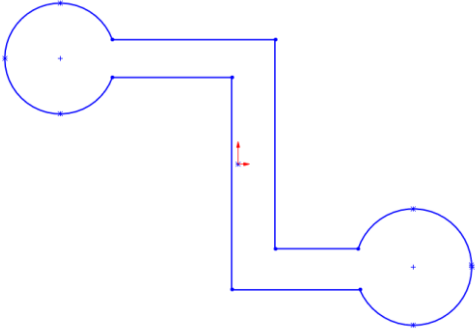
The test cases listed in Table 4.4 were run within the expert system and results were tabulated in Table 4.6. The overall verification instances and the linkage between the results are described in Table A.1 in Appendix A.

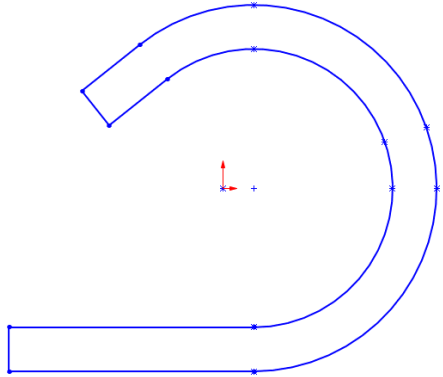
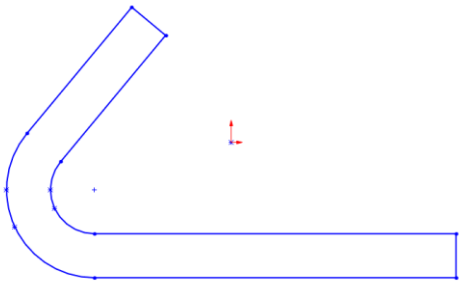
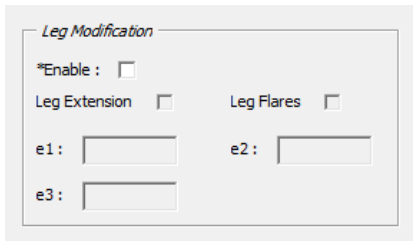
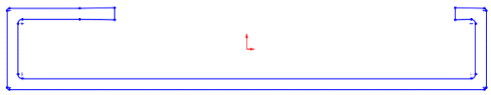

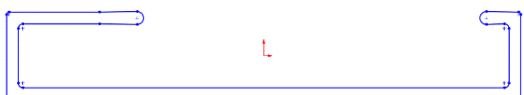
**Table 4.6** Results From Running the Test Cases From Table 4.4 in the Expert System

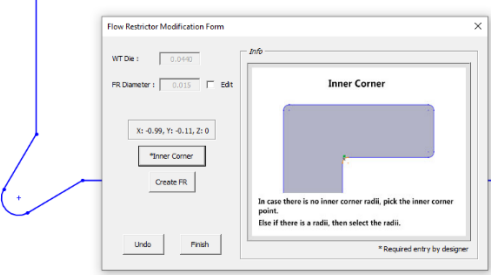
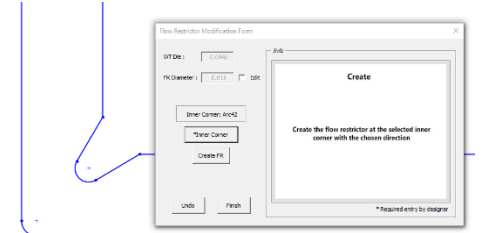
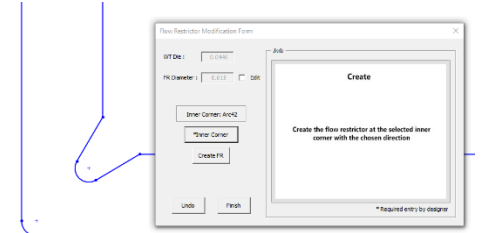
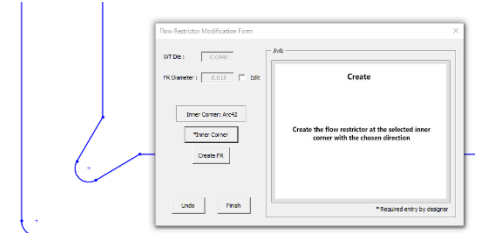
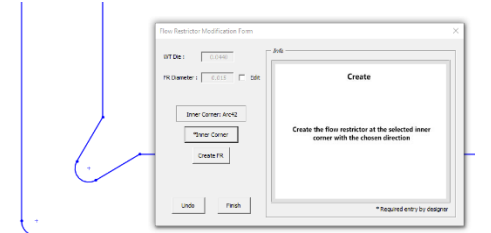
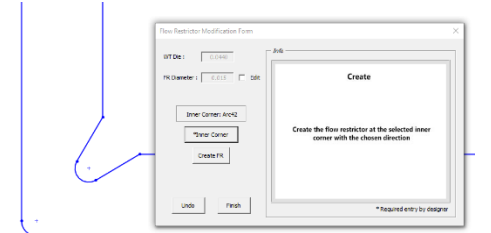


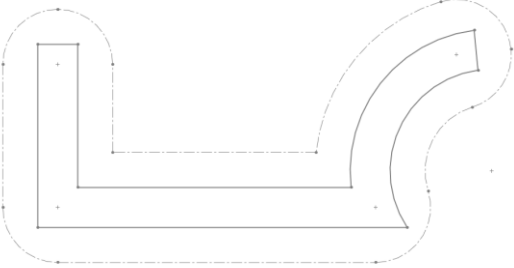
Routine Name	ID	Results Description	Results Image
ExtToolMain	1	The program was initialized and the main graphical user interface was loaded. The user can now proceed with selecting the product profile and click on the Verify button as shown in the result image.	
	2	An error message will appear, “The excel database could not be found, has it been renamed or deleted?”	
	3	Program will not run and say the particular file has not been found.	
DXFImport	4	The following error message was obtained, "Browse and select a product profile"	
	5	Program did not run as expected and alerted the user regarding the error.	

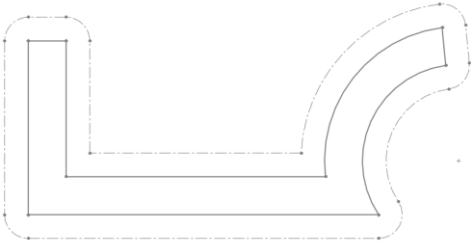
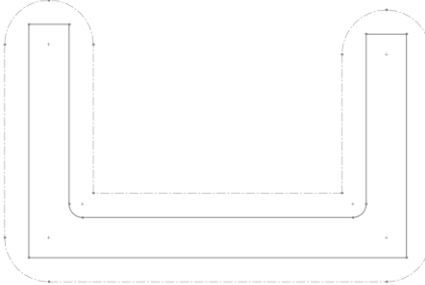
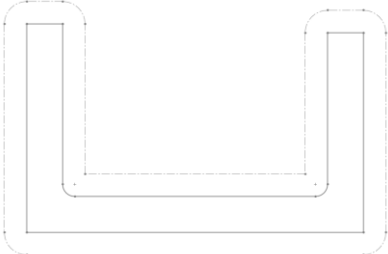
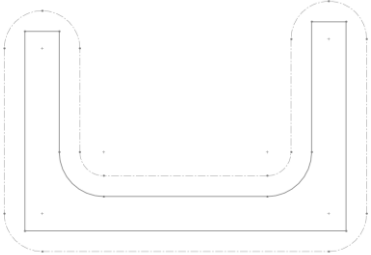
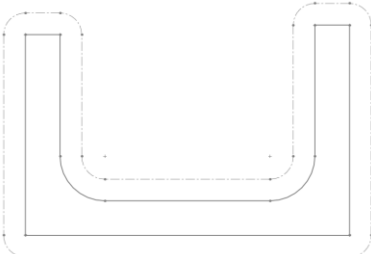
Routine Name	ID	Results Description	Results Image
	6	File with the unsupported format was not able to be selected since a filter is set to only show .DXF files.	A text file was used as test case
PolygonFix	7	A pop-up window will appear showing the user the locations of the gap so that the designer can manually join the entities.	
	8	A pop-up window will appear showing the user the locations of the gap so that the designer can manually join the entities.	
	9	The designer can enter an upper limit on the pop up window which will show all gaps less than that value.	
	10	Designer can enter an upper limit on the repair tool box that pops up which will show all gaps less than that value.	

Routine Name	ID	Results Description	Results Image
	11	A pop-up window will appear showing the user the locations of the gap so that the designer can manually join the entities.	
	12	The 0 length entities were automatically removed during the import process.	
	13	The sketch was analyzed and all the entities were arranged in a counterclockwise order.	
	14	Program stopped executing with a message box stating unsupported entity has been found. The unsupported entity was also highlighted on the SolidWorks window.	
TrueCenter	15	Center of the geometry was found and verified.	

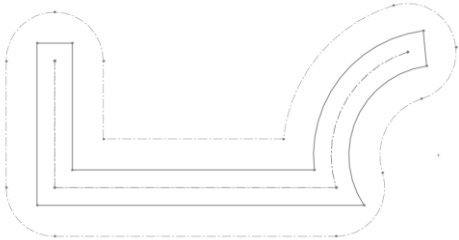

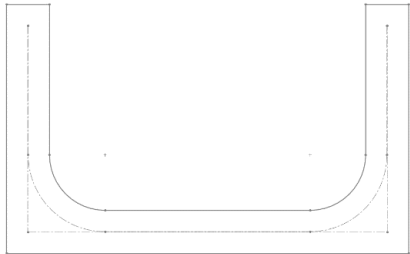
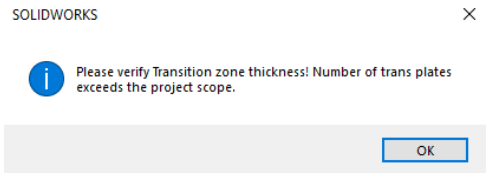
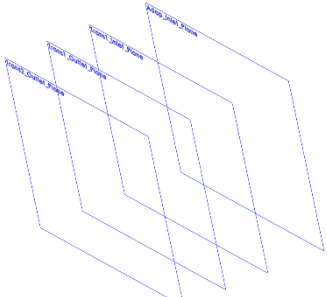
Routine Name	ID	Results Description	Results Image
	16	Center of the geometry was found and verified.	
	17	Center of the geometry was found and verified.	
	18	Center of the circle was determined as the true center.	
	19	Center of the geometry was found and verified.	

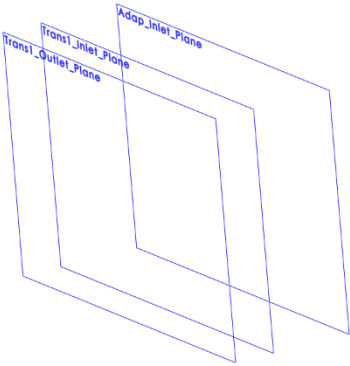
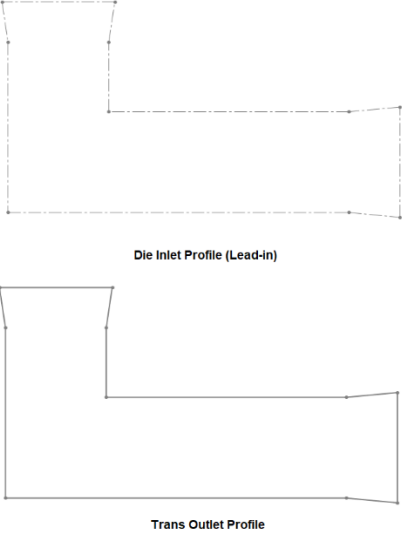
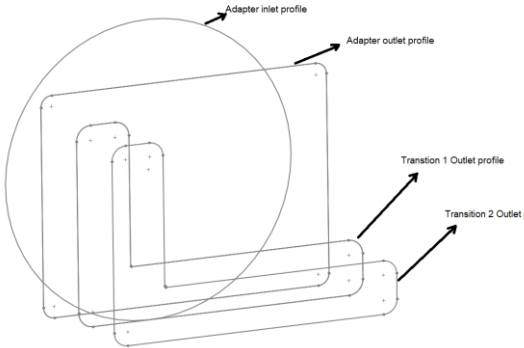
Routine Name	ID	Results Description	Results Image
TrueCenter Arcs	20	Points were created at the +y, +x and -y at radial distances. Point at -y was not created since it does not lie on the arc. Center of the geometry was found and verified.	
	21	Point was created at the -y at radial distances. The rest of the points were not created since they do not lie on the arc. Center of the geometry was found and verified.	
LegMod	22	If the designer specifies that leg modifications aren't required, the program will skip the module.	
	23	The routine identifies the type of leg and proceeds to modify it accordingly.	
	24	The routine identifies the type of leg and proceeds to modify it accordingly.	
25	The routine identifies the type of leg and proceeds to modify it accordingly.		

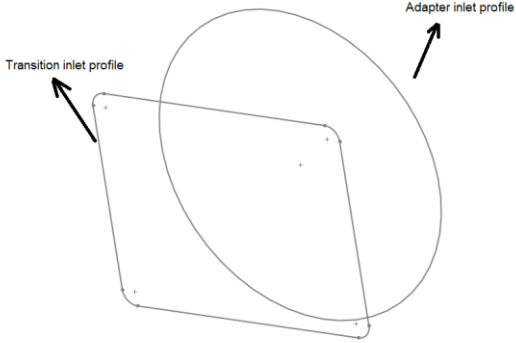
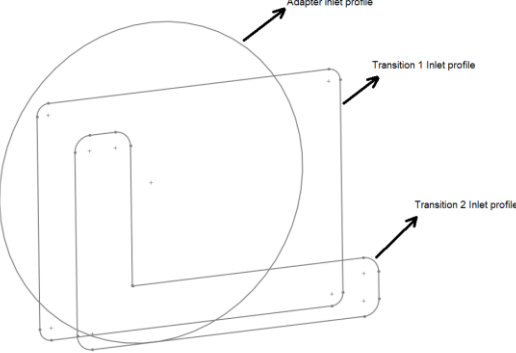
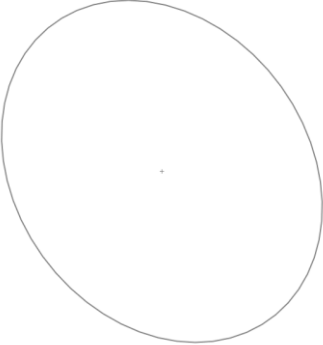
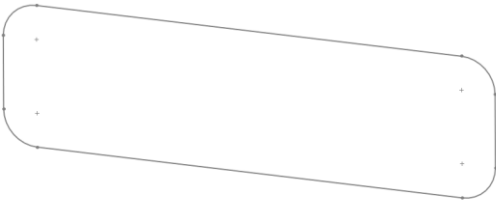
Routine Name	ID	Results Description	Results Image
FlowRestrictor	26	Flow restrictor was created successfully at the selected point.	
	27		
	28		
FlowRestrictor	29	Flow restrictor was created successfully at the selected arc.	
	30		
	31		
	32	Flow restrictor was created successfully.	
	33	Flow restrictor was created successfully.	
LeadIn	34	The program selected the right ball end mill diameter and the lead-in was designed. The outer radii of the lead-in will be the same as the ball-end mill radii. The inner corner will always be sharp.	

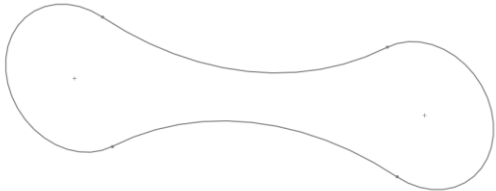
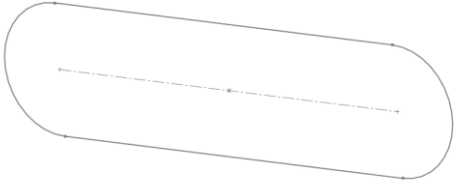
Routine Name	ID	Results Description	Results Image
	35	The program selected the chamfer end mill and the lead-in was designed. The outer radii of the lead-in will be the same value as the offset and the inner corners will be sharp.	
	36	The program selected the right ball end mill diameter and the lead-in was designed. The outer radii of the lead-in will be the same as the ball-end mill radii. The inner corner will always be sharp.	
	37	The program selected the chamfer end mill and the lead-in was designed. The outer radii of the lead-in will be the same value as the offset and the inner corners will be sharp.	
	38	The program selected the right ball end mill diameter and the lead-in was designed. The outer radii of the lead-in will be the same as the ball-end mill radii. The inner corner will always be sharp.	
	39	The program selected the chamfer end mill and the lead-in was designed. The outer radii of the lead-in will be the same value as the offset and the inner corners will be sharp.	



Routine Name	ID	Results Description	Results Image
Toolpath	40	Toolpath will get correctly offset and the geometry will be generated. Toolpath is only generated for Ball lead-in.	
	41	Toolpath will get correctly offset and the geometry will be generated. Toolpath is only generated for Ball lead-in.	
	42	Toolpath will get correctly offset and the geometry will be generated. Toolpath is only generated for Ball lead-in.	
TransPlateNo	43	Return a message to the user that the current set of values is not supported.	
	44	The routine will create planes representing the two transition plates. Both the plates will have the same thickness.	

Routine Name	ID	Results Description	Results Image
	45	The routine will create planes to represent a single transition plate with the plate thickness same as transition zone thickness.	
TransOutlet	46	The routine will use convert entities tool to make the trans outlet profile the same as the lead-in profile on the die inlet.	
	47	<p>The first transition plate will have the same outlet profile as the lead-in on the die inlet profile.</p> <p>The outlet profile of the second transition plate will be designed such that it creates an intermediary profile between the transition and the adapter profile.</p>	

Routine Name	ID	Results Description	Results Image
TransInlet	48	The inlet profile of the transition plate will be the same as the outlet profile of the adapter plate.	
	49	In this case, the inlet profile on the first transition plate will be an offset of the die lead-in profile. The inlet profile on the second transition plate will be the same as the outlet on the adapter plate.	
AdapOutlet	50	A round profile was created at the adapter outlet	
	51	A rectangular profile was created at the adapter outlet	

<b>Routine Name</b>	<b>ID</b>	<b>Results Description</b>	<b>Results Image</b>
	52	An hourglass profile was created at the adapter outlet	
	53	A slot profile was created at the adapter outlet	

Source: New Jersey Precision Technologies

The real design test cases represented in Table 4.5 were also run through the expert system and the overall design time taken for creating the output drawing sheets were compared with the manual design times recorded by the designers at NJPT and is tabulated in Table 4.7

**Table 4.7** Comparison of Manual Design Time with Program Design Time

<b>Job No</b>	<b>Plates</b>	<b>Designer</b>	<b>Manual Design Time (mins)</b>	<b>Program Design Time (mins)</b>	<b>% Time Reduction</b>
48799	Die	Jorge	112.2	4.97	95.57
41640	Die	Andrew	471	5.55	98.82
	Trans				
45629	Die	Andrew	204	5.88	97.11
	Trans				

Job No	Plates	Designer	Manual Design Time (mins)	Program Design Time (mins)	% Time Reduction
46544	Die	Gabriel	291	8.71	97
	Trans				
48464	Die	Gabriel	198	5.51	97.21
49726	Die	Michal	125.4	4.27	96.59
	Trans				

Source: New Jersey Precision Technologies

The generated drawing sheets for the test cases in Table 4.5 have been attached in Appendix C. We can thus see that that the program has achieved significant reduction in generating designs when compared to manual design time for all the analyzed cases. The percentage in time difference is calculated using the following formula,

$$\%TimeDiff = \frac{\text{Manual Design Time} - \text{Program Design Time}}{\text{Manual Design Time}} \times 100 \quad (4.18)$$

**Table 4.8** Output from Expert System Printed Into a Preliminary Knowledge Base

DetailID	Mat	Prod.OL	Prod.OH	Prod.WT	WTDie	DDA	WT%	Tool
48799001	HIPS	1.4	0.605	0.04	0.044	0.3	0.09	DIE
48799002	HIPS	1.4	0.605	0.04	0.044	0.3	0.09	TRANS 1
48799003	HIPS	1.4	0.605	0.04	0.044	0.3	0.09	ADAPTER
41640001	HDPE	1.125	1.25	0.065	0.077	0.4	0.1	DIE
41640002	HDPE	1.125	1.25	0.065	0.077	0.4	0.1	TRANS 1
41640003	HDPE	1.125	1.25	0.065	0.077	0.4	0.1	ADAPTER
45629001	RPVC	1.0548	0.7468	0.06	0.065	0.2	0.08	DIE
45629002	RPVC	1.0548	0.7468	0.06	0.065	0.2	0.08	TRANS 1
45629003	RPVC	1.0548	0.7468	0.06	0.065	0.2	0.08	ADAPTER
46544001	ABS	3.3726	1.0935	0.06	0.066	0.25	0.1	DIE

<b>DetailID</b>	<b>Mat</b>	<b>Prod.OL</b>	<b>Prod.OH</b>	<b>Prod.WT</b>	<b>WTDie</b>	<b>DDA</b>	<b>WT%</b>	<b>Tool</b>
46544002	ABS	3.3726	1.0935	0.06	0.066	0.25	0.1	TRANS 1
46544003	ABS	3.3726	1.0935	0.06	0.066	0.25	0.1	TRANS 2
46544004	ABS	3.3726	1.0935	0.06	0.066	0.25	0.1	ADAPTER
48464001	Acrylic	0.5	0.4375	0.0937	0.108	0.28	0.15	DIE
48464002	Acrylic	0.5	0.4375	0.0937	0.108	0.28	0.15	TRANS 1
48464003	Acrylic	0.5	0.4375	0.0937	0.108	0.28	0.15	ADAPTER
49726001	HIPS	0.938	0.094	0.03199	0.035	0.3	0.09	DIE
49726002	HIPS	0.938	0.094	0.03199	0.035	0.3	0.09	TRANS 1
49726003	HIPS	0.938	0.094	0.03199	0.035	0.3	0.09	ADAPTER

All the variables that were used in each design is output into a database as seen in Table 4.8, that will add on to the existing knowledge base and thus create more successful information regarding every design which can be further used for creating a completely autonomous design using machine learning algorithms.

## CHAPTER 5

### CONCLUSIONS, LIMITATIONS AND FUTURE WORK

#### 5.1 Conclusion

Automated Engineering Design provides a potential pathway to address not only the Skills Gap but also the transfer of information from SMEs to a new generation of engineers. The question remained whether a decision heavy area such as ME Design could be automated. This required establishing a collaboration with an industry partner New Jersey Precision Technologies (NJPT) in order to evaluate this question with an industry relevant case. The case selected was Plastic Extrusion Tooling Design for several reasons, namely:

- The design is currently driven by a limited number of SMEs who are completing their careers without overlap to transfer knowledge to the next generation
- The demand for plastic extrusion tooling design has not decreased
- Plastic extrusion design requires a rapid turn-around time.

The Expert System developed in this thesis compiled relevant design information and methods, standardized their use in design, and resulted in a considerable reduction in design time needed for several real-world cases of Plastic Extrusion Die Tooling. This thesis therefore, successfully tested the hypothesis that a decision heavy area such as ME design can be automated in a case of plastic extrusion die tooling. This was accomplished by establishing multiple stages towards automation, namely: Design Definition, Task Differentiation, Workflow Generation, and Expert System Development. These stages provide a process foundation for ME Design Automation. They would need to be

implemented in other ME design cases in order to establish whether they can be utilized in a broader context in automating ME Design.

The current study was limited in all cases for plastic extrusion tooling design. There are several other design components like the experiential methods listed in Table 3.2, the cooling tools that are part of every extrusion tool such as vacuum calibrators and profiles that are out of the current scope of the project especially hollow profiles, really large profiles that require more than two transition plates, complex profiles having variable wall thickness and finally procedure of designing extrusion tooling that will support multiple feed input, which would need to be developed and tested as part of future work to ensure utility for all plastic extrusion cases. In addition, only six real world cases were evaluated. This study limitation will need to be addressed by evaluating other industry relevant examples in future work. The Expert System was preliminarily evaluated and will need to be utilized for a greater period of time by industry designers in order to evaluate its full effectiveness and refine any problems that may arise.

The Expert System does provide a further avenue for future work through its output into a database. This feature allows further exploration into whether Machine Learning and other AI methods could be utilized to address the experience-based decisions that are present in the design process. In summary, this thesis has demonstrated the capability of automating ME design through an industry relevant case study, the potential impact in industry for knowledge transfer and turnaround time, and next steps towards the application of AI.



## REFERENCES

- Adecco (2018). Design Engineering & CAD Jobs in High Demand. Retrieved July 1, 2019, from <http://blog.adeccousa.com/top-design-engineering-cad-jobs/>
- Amadori, K., Tarkian, M., Ölvander, J., & Krus, P. (2012). Flexible and robust CAD models for design automation. *Advanced Engineering Informatics*, 26(2), 180–195. <https://doi.org/10.1016/j.aei.2012.01.004>.
- ANSYS Polyflow. Retrieved July 1, 2019, from <https://www.ansys.com/products/fluids/ansys-polyflow>
- ANVIL1000MD. Retrieved July 1, 2019, from <http://www.anvil1000md.com/about-anvil/>
- Arda, D.R. and M.R. Mackley, The effect of die exit curvature, die surface roughness and a fluoropolymer additive on sharkskin extrusion instabilities in polyethylene processing. *Journal of Non-Newtonian Fluid Mechanics*, 2005. 126(1): p. 47-61.
- Artificial Intelligence (AI) vs. Machine Learning vs. Deep Learning. (2018). Retrieved July 1, 2019, from <https://skymind.ai/wiki/ai-vs-machine-learning-vs-deep-learning>
- Auvinen, K. (2013). Entrepreneurial guide to starting up a plastics extrusion business.
- Awad, E. M. (2003). Building Knowledge Automation Expert Systems with Exsys Corvid, Exsys Incorporated.
- Beck, R.D., Plastic product design. 1970: Van Nostrand Reinhold Co
- Benaouali, A. and S. Kachel (2017). An automated CAD/CAE integration system for the parametric design of aircraft wing structures.
- Brown, R.J. Predicting How the Cooling and Resulting Shrinkage of Plastics Affect the Shape and Straightness of Extruded Profiles (200). in TECHNICAL PAPERS OF THE ANNUAL TECHNICAL CONFERENCE-SOCIETY OF PLASTICS ENGINEERS INCORPORATED. 2000.
- Carneiro, O., & Nobrega, J. (2012). Design of Extrusion Forming Tools. Shrewsbury: iSmithers Rapra Publishing.
- Cederfeldt, M. (2007). Planning Design Automation: A Structured Method and Supporting Tools.
- Chen, B., & Xie, Y. (2017). Functional knowledge integration of the design process. *Science China Technological Sciences*, 60(2), 209–218. <https://doi.org/10.1007/s11431-016-0236-8>.
- Deloitte (2015). Skills Gap in Manufacturing. Retrieved July 1, 2019, from <http://www.themanufacturinginstitute.org/~media/827DBC76533942679A15EF7067A704CD.ashx>

- Eklund, A., & Karner, J. (2017). Development of a Framework for Concept Selection and Design Automation: Utilizing hybrid modeling for indirect parametric control of subdivision surfaces.
- Elgeti, S., et al., Numerical shape optimization as an approach to extrusion die design. *Finite Elements in Analysis and Design*, 2012. 61: p. 35-43
- Ettinger, H.J., et al., Parameterization and optimization strategies for the automated design of uPVC profile extrusion dies. *Structural and Multidisciplinary Optimization*, 2004. 28(2-3)
- Finger, S. and J. R. Dixon (1989). A review of research in mechanical engineering design. Part I: Descriptive, prescriptive, and computer-based models of design processes.
- Fuge, M., Peters, B., & Agogino, A. (2014). Machine Learning Algorithms for Recommending Design Methods. *Journal of Mechanical Design*, 136(10), 1–8. <https://doi.org/10.1115/1.4028102>
- Girardin, L. (2017). What's the Difference Between Automation, Artificial Intelligence and Machine Learning? Retrieved July 1, 2019, from <https://www.govloop.com/community/blog/whats-difference-automation-artificial-intelligence-machine-learning/>
- Grasz, J. (2014). Companies Losing Money to the Skills Gap. Retrieved July 1, 2019, from <https://cb.com/2XXuWTB>
- Gonçalves, N.D., O.S. Carneiro, and J.M. Nóbrega, Design of complex profile extrusion dies through numerical modeling. *Journal of Non-Newtonian Fluid Mechanics*, 2013. 200: p. 103-110.
- Groover, Mikell (2014). *Fundamentals of Modern Manufacturing: Materials, Processes, and Systems*.
- Guitrau, E. (1997). *The EDM handbook*. Cincinnati: Hanser Gardner Publications.
- Hague, R., Mansour, S., & Saleh, N. (2004). Material and design considerations for rapid manufacturing. *International Journal of Production Research*, 42(22), 4691–4708. <https://doi.org/10.1080/00207840410001733940>.
- Henriques, G., & Stacey, D. (2014). *Leveraging Knowledge Through Ontology Design*.
- Hopgood, Adrian A. “*Intelligent Systems for Engineers and Scientists*”, CRC Press, 2012.
- Jacob, D., Ramana, K., & Rao, P. (2004). Automated manufacturability assessment of rotational parts by grinding. *International Journal of Production Research*, 42(3), 505–519. <https://doi.org/10.1080/00207540310001613674>.
- Johansson, J. (2008). *Design Automation Systems for Production Preparation: Applied on the Rotary Draw Bending Process*. Chalmers, Göteborg.
- Kim, W., & Simpson, T. (2013). Toward Automated Design for Manufacturing Feedback. In *IFIP Advances in Information and Communication*

- Technology (Vol. AICT-414, pp. 40–47). Springer. [https://doi.org/10.1007/978-3-642-41266-0\\_5](https://doi.org/10.1007/978-3-642-41266-0_5).
- Kolodner, J.L., An introduction to case-based reasoning. *Artificial intelligence review*, 1992. 6(1): p. 3-34.
- Kong, L., et al., A Windows-native 3D plastic injection mold design system. *Journal of Materials processing technology*, 2003. 139(1): p. 81-89.
- Lafleur, P.G. and B. Vergnes, *Polymer extrusion*. 2014: John Wiley & Sons.
- Lee, K. and C. Luo, Application of case-based reasoning in die-casting die design. *The International Journal of Advanced Manufacturing Technology*, 2002. 20(4): p. 284-295.
- Liang, J.-Z., A relationship between extrudate swell ratio and entry stored elastic strain energy during die flow of tyre compounds. *Polymer Testing*, 2004. 23(4): p. 441-446.
- Lynch, P., & Aqlan, F. (2016). Filling the skills gap in U.S. manufacturing: Promoting internships and co-op experiences and integrating industrial engineering courses to improve student design and manufacturing knowledge. In 2016 IEEE Frontiers in Education Conference (FIE) (Vol. 2016-, pp. 1–8). IEEE. <https://doi.org/10.1109/FIE.2016.7757590>
- Mechanical Designer: Job Roles and Requirements. (2016). Retrieved from [https://study.com/articles/Mechanical\\_Designer\\_Job\\_Description\\_Duties\\_and\\_Requirements.html](https://study.com/articles/Mechanical_Designer_Job_Description_Duties_and_Requirements.html)
- Nan, J., & Li, Q. (2012). Design Automation System-Supporting Documentation and Management.
- Nobrega, J.M., et al., Flow Balancing in Extrusion Dies for Thermoplastic Profiles. 2004.
- Osswald, T. A., et al. (2006). *International Plastics Handbook*. International Plastics Handbook, Carl Hanser Verlag GmbH & Co.
- Pahl, G., Wallace, K., & Blessing, L. (2007). *Engineering design : a systematic approach* (3rd ed.). London: Springer.
- Pauli, L., M. Behr, and S. Elgeti, Towards shape optimization of profile extrusion dies with respect to homogeneous die swell. *Journal of Non-Newtonian Fluid Mechanics*, 2013. 200: p. 79-87.
- Plastic flow, PolyXtrue. Retrieved July 1, 2019, from <http://www.plasticflow.com/monoex.html>
- Rajkumar, A., et al., Design Guidelines to Balance the Flow Distribution in Complex Profile Extrusion Dies. *International Polymer Processing*, 2017. 32(1): p. 58-71.
- Rauwendaal, C., *Polymer extrusion*. 2014: Carl Hanser Verlag GmbH Co KG.
- Reddy, E.J., C. Sridhar, and V.P. Rangadu, Research and Development of Knowledge Based Intelligent Design System for Bearings Library Construction Using SolidWorks API, in *Intelligent Systems Technologies and Applications*. 2016, Springer. p. 311-319.

- Rezaei Shahreza, A., et al., Design, optimization, and manufacturing of a multiple-thickness profile extrusion die with a cross flow. *Polymer Engineering & Science*, 2010. 50(12): p. 2417-2424.
- Rocca, G. L. (2012). "Knowledge based engineering: Between AI and CAD. Review of a language-based technology to support engineering design." *Advanced Engineering Informatics* 26(2): 159-179.
- Saric, I., Muminovic, A., Colic, M., & Rahimic, S. (2017). Development of integrated intelligent computer-aided design system for mechanical power-transmitting mechanism design. *Advances in Mechanical Engineering*, 9(7).  
<https://doi.org/10.1177/1687814017710389>
- Shukor, S., & Axinte, D. (2009). Manufacturability analysis system: issues and future trends. *International Journal of Production Research*, 47(5), 1369–1390.  
<https://doi.org/10.1080/00207540701589398>.
- Sriram, R.D., (1997), “Intelligent Systems for Engineering: A Knowledge-Based Approach”, Springer-Verlag Ltd., London, Great Britain.
- Sunnersjö, S. Planning design automation systems for product families-a coherent, top down approach. in *Proceedings of the 12th International Design Conference DESIGN 2012*.
- Sunnersjo, S, (2009), An empirical study of aspects of knowledge used in engineering design - A design automation perspective; 2 nd Nordic Conference on Product Lifecycle Management - NordPLM’09, Göteborg, Sweden.
- Tadmor, Z. and C.G. Gogos, *Principles of polymer processing*. 2013: John Wiley & Sons.
- Titow, M., *PVC technology*. 2012: Springer Science & Business Media. pp. 426 , 482 – 487.
- Trehan, V., et al. (2015). "Informal and formal modelling of engineering processes for design automation using knowledge-based engineering." *Journal of Zhejiang University-SCIENCE A* 16(9): 706-723.
- Ulysse, P., *Extrusion die design for flow balance using FE and optimization methods*. *International Journal of Mechanical Sciences*, 2002. 44.
- Verhagen, W.. J., Bermell-Garcia, P., van Dijk, R. E. & Curran, R., 2012. A critical review of Knowledge-Based Engineering: An identification of research challenges. *Advanced Engineering Informatics*, Issue 26, pp. 5-15.
- Wagner, J. R., et al. (2014). 1 - Extrusion Process. *Extrusion (Second Edition)*. J. R. Wagner, E. M. Mount and H. F. Giles. Oxford, William Andrew Publishing: 3-11.
- Williams, M. (2018). Retrieved July 1, 2019, from  
<http://www.eurekamagazine.co.uk/design-engineering-blogs/bridging-the-skills-gap-with-automated-engineering/172470/>
- Yilmaz, O., H. Gunes, and K. Kirkkopru, Optimization of a profile extrusion die for flow balance. *Fibers and Polymers*, 2014. 15: p. 753-761.

Zbiciak, M., et al. (2015). "An automation of design and modelling tasks in NX Siemens environment with original software - generator module." IOP Conference Series: Materials Science and Engineering 95: 012117.

Zhu, Y., Plastic Profile Extrusion Die. 2009: Peking Chemical and Industrial. pp. 35.

Zigu. (n.d.). Skill Gap Definition: Human Resources (HR) Dictionary. Retrieved July 30, 2019, from <https://www.mbaskool.com/business-concepts/human-resources-hr-terms/2134-skill-gap.html>.

## APPENDIX A

### PROGRAM VERIFICATION INSTANCES

Table A.1 listing all the possible instances to verify after analyzing every routine in the expert system.

**Table A.1** Verification Instances of Routines in Expert System

I D	A r e a	N o .	N a m e	Routine Description	Possible Instances	Program Design Feature	Test Case	Result
A	I n i t i a l  R o u t i n e  P r e p .	1	E x t T o l M a i n	Checks if the referenced documents are present.	a. All referenced documents were successfully located and connections were established.	Program moves to the next step.	PERFECT CASE (Refer Table 4.4. Test Case ID: P1A1a)	The program was initialized and the main graphical user interface was loaded. (Refer Table 4.6. Result ID 1)
				Sets up connection with SolidWorks and the referenced documents which include the excel database and information pictures.	b. Excel database does not exist	The program will stop running and can only continue once the database has been linked	Rename excel sheet or change its location. (Refer Table 4.4. Test Case ID: P1A1b)	An error message will appear, "The excel database could not be found, has it been renamed or deleted?" (Refer Table 4.6. Result ID 2)
					c. Info pictures will have been moved	Program will not be able to load the picture and thus won't be able to display it on the graphical user interface.	Remove a test picture path. (Refer Table 4.4. Test Case ID: P1A1c)	Program will not run and say the particular file has not been found. (Refer Table 4.6. Result ID 3)

<b>ID</b>	<b>Area</b>	<b>No.</b>	<b>Name</b>	<b>Routine Description</b>	<b>Possible Instances</b>	<b>Program Design Feature</b>	<b>Test Case</b>	<b>Result</b>
B	Profile Import	2	DXF Import	Imports selected .DXF file as a new part on SolidWorks.	a. Empty or no file is given as input.	Program should not run and should alert the user regarding the error	Do not import a file when running the program. (Refer Table 4.4. Test Case ID: P1B1a)	The following error message was obtained, "Browse and select a product profile" (Refer Table 4.6. Result ID 4)
					b. A renamed file having .dxf even though it is not a DXF file.	Program should not run and will alert the user that the file is corrupt.	Create a text file and rename it to test.dxf. (Refer Table 4.4. Test Case ID: P1B1b)	Program did not run as expected and alerted the user regarding the error. (Refer Table 4.6. Result ID 5)
					c. A file with a different file format is given as input.	Program should not be able to select an unsupported file format	Try to import a file with an unsupported file format. (Refer Table 4.4. Test Case ID: P1B1c)	File with the unsupported format was not able to be selected. (Refer Table 4.6. Result ID 6)
C	Verify Profile	3	Polygon Fix	Repairs the sketch. Arrange the entities of the profile in a counter-clockwise manner. Identifies the base segment of the profile and arranges all the segments in such a way that the end point is connected to the start point of the next segment.	a. The sketch file will have disjointed entities or gaps.	Program will be able to detect and help fix gaps in the profile.	a. Gap: 0.00005 in. (Refer Table 4.4. Test Case ID: P1C3aa)	A pop-up window appears showing the gaps the so that the designer can manually join the entities. (Refer Table 4.6. Result ID 7)
							b. Gap: 0.0005 in. (Refer Table 4.4. Test Case ID: P1C3ab)	A pop-up window will show the locations of the gap so that the designer can manually join the entities. (Refer Table 4.6. Result ID 8)
							c. Gap: 0.005 in. (Refer Table 4.4. Test Case ID: P1C3ac)	The designer can enter an upper limit which will show all gaps less than that value. (Refer Table 4.6. Result ID 9)

I D	A r e a	N o .	N a m e	R o u t i n e D e s c r i p t i o n	P o s s i b l e I n s t a n c e s	P r o g r a m D e s i g n F e a t u r e	T e s t C a s e	R e s u l t
							d. Gap: 0.05 in. (Refer Table 4.4. Test Case ID: P1C3ad)	The designer can enter an upper limit which will show all gaps less than that value. (Refer Table 4.6. Result ID 10)
					b. The sketch could have overlapping entities.	The overlapping entities will be merged.	Test sketch DXF created with overlapping entities. (Refer Table 4.4. Test Case ID: P1C3b)	A pop-up window will show the locations of the gap so that the designer can manually join the entities. (Refer Table 4.6. Result ID 11)
					c. The sketch could have 0 length entities.	The 0 length entities will be detected and removed	Test DXF file created containing 0 length entities. (Refer Table 4.4. Test Case ID: P1C3c)	The 0 length entities were automatically removed during the import process. (Refer Table 4.6. Result ID 12)
					d. Sketch can contain 2000 entities. *	Program will still perform the way it is meant to	DXF contains 2000 entities. (Refer Table 4.4. Test Case ID: P1C3d)	The program ran successfully till the end. (Refer Table 4.6. Result ID 13)
				* After analysis of historical database of jobs done at NJPT, 99% of the cases contained entities less than 2000.				
					e. Sketch can contain entities like spline or ellipse.	Program will inform the designer regarding the unsupported entity	Test DXF file created containing unsupported entities. (Refer Table 4.4. Test Case ID: P1C3e)	Program stopped executing with a message box stating unsupported entity has been found. The unsupported entity was also



I D	A r e a	N o .	N a m e	R o u t i n e D e s c r i p t i o n	P o s s i b l e I n s t a n c e s	P r o g r a m D e s i g n F e a t u r e	T e s t C a s e	R e s u l t
								highlighted on the SolidWorks window. (Refer Table 4.6. Result ID 14)
		4	True Center	<p>Determines the midpoint of the profile and will align the sketch so that the midpoint lies on the origin.</p> <p>Determines the maximum and minimum bounding points of the sketch and calculates the midpoint.</p> <p>Since arcs in SolidWorks do not supply point information at the maximum and minimum locations, points are created at the +x, +y, -x and -y direction at a radial distance.</p>	<p>a. Sketch contains a 3-sided polygon.</p> <p>b. Sketch contains a 4-sided polygon.</p> <p>c. Closed sketch can contain 2000 entities. *</p> <p>* After analysis of historical database of jobs done at NJPT, 99% of the cases had less than 2000.</p> <p>d. Sketch can be a simple circular profile.</p>	<p>Will determine the geometric center of the polygon and align the midpoint of the profile to the origin</p>	<p>Test DXF file containing 3-sided polygon. (Refer Table 4.4. Test Case ID: P1C4a)</p> <p>Test DXF file containing 4-sided polygon. (Refer Table 4.4. Test Case ID: P1C4b)</p> <p>DXF file containing a profile with 2000 entities. (Refer Table 4.4. Test Case ID: P1C3d)</p> <p>DXF file containing a simple circle. (Refer Table 4.4. Test Case ID: P1C4d)</p>	<p>Center of the geometry was found and verified. (Refer Table 4.6. Result ID 15)</p> <p>Center of the geometry was found and verified. (Refer Table 4.6. Result ID 16)</p> <p>Center of the geometry was found and verified. (Refer Table 4.6. Result ID 17)</p> <p>Center of the circle was determined as the true center. (Refer Table 4.6. Result ID 18)</p>

I D	A r e a	N o .	N a m e	R o u t i n e D e s c r i p t i o n	P o s s i b l e I n s t a n c e s	P r o g r a m D e s i g n F e a t u r e	T e s t C a s e	R e s u l t
					e. Closed sketch containing arcs and line segments.		DXF file containing profile having lines and arcs as segments. (Refer Table 4.4. Test Case ID: P1C4e)	Center of geometry was found and verified. (Refer Table 4.6. Result ID 19)
		5	TrueCenter	TrueCenter works by creating a bounding box around the profile based on points from the sketch but arcs in SolidWorks do not supply point information Hence, points are created at the +x, +y, -x and -y direction at a radial distance around the arc. This function will check if the points will lie on the arc and if it returns true, then it creates them.	a. Sketch contains major arcs.  b. Sketch contains minor arcs.	Will determine the orientation of the arc and create points in +x, +y, -x and -y direction at radial distance only if they will lie on the arc.	DXF file containing a profile having major arcs. (Refer Table 4.4. Test Case ID: P1C5a)  DXF file containing a profile having minor arcs. (Refer Table 4.4. Test Case ID: P1C5b)	Only the points that will lie on the arc are created. (Refer Table 4.6. Result ID 20)  Only the points that will lie on the arc are created. (Refer Table 4.6. Result ID 21)
	Modify	6	LegMod	Add flares or extensions or both to the ends of the legs	a. Profile does not have any legs.	The program will not determine the presence of legs instead it relies on the designer to activate the	Test DXF file created containing a profile with no legs. (Refer Table 4.4. Test Case ID: P1C4b)	If the designer specifies that leg modifications aren't required, the program will skip the module. (Refer Table 4.6. Result ID 22)

<b>I D</b>	<b>A r e a</b>	<b>N o .</b>	<b>N a m e</b>	<b>Routine Description</b>	<b>Possible Instances</b>	<b>Program Design Feature</b>	<b>Test Case</b>	<b>Result</b>	
	L e g s			depending on selection.	<p>b. Profile has legs with flat ends.</p> <p>c. Profile has legs with flat ends and corner radii.</p> <p>d. Profile has legs with a curved end.</p> <p>e. An incorrect segment is selected during leg modification</p>	leg modification module in case its required.	Test DXF file created containing a profile with flat end legs. (Refer Table 4.4. Test Case ID: P1D6b)	The routine identifies the type of leg and proceeds to modify it accordingly. (Refer Table 4.6. Result ID 23)	
				Determine the length of the leg based on input from designer. Determine the type of the leg and appropriately assign modifies the legs.		The routine will determine the type of the leg,			Flat end leg: Type 1  Leg with flat end and curved radii: Type 2 Curved end leg: Type 3
						And perform the necessary modifications.	Test DXF file created containing a profile with full radii legs. (Refer Table 4.4. Test Case ID: P1D6d)	The routine identifies the type of leg and proceeds to modify it accordingly. (Refer Table 4.6. Result ID 25)	
									A wrong segment is selected during leg modification.
E		7		Determine the location of the flow restrictor at the corner so that the distance between the	a. An incorrect segment is selected during flow restrictor modification	The routine will fail as it will modify the profile incorrectly.	A wrong segment is selected during flow restrictor modification.	Added an Undo button in the leg modification form to step back in case of errors.	

ID	Area	No.	Name	Routine Description	Possible Instances	Program Design Feature	Test Case	Result
Adding Flow Restrictors			Flow Restrictor	flow restrictor and the outside wall is the adjusted wall thickness of the profile.	b. Inner corner is a point.	Appropriate dimensions of the flow restrictor are calculated and is sketched	a. Inner corner is a point lying between two lines. (Refer Table 4.4. Test Case ID: P1E7ba)	Flow restrictor was created successfully at the selected point. (Refer Table 4.6. Result ID 26)
							b. Inner corner is a point lying between two arcs. (Refer Table 4.4. Test Case ID: P1E7bb)	Flow restrictor was created successfully at the selected point. (Refer Table 4.6. Result ID 27)
							c. Inner corner is a point lying between an arc and a line. (Refer Table 4.4. Test Case ID: P1E7bc)	Flow restrictor was created successfully at the selected point. (Refer Table 4.6. Result ID 28)
					c. Inner corner is a radius.	Appropriate dimensions of the flow restrictor are calculated and is sketched	a. Inner corner is a radius lying between two lines. (Refer Table 4.4. Test Case ID: P1E7ca)	Flow restrictor was created successfully at the selected arc. (Refer Table 4.6. Result ID 29)
							b. Inner corner is a radius lying between two arcs. (Refer Table 4.4. Test Case ID: P1E7cb)	Flow restrictor was created successfully at the selected arc. (Refer Table 4.6. Result ID 30)
							c. Inner corner is a radius]h lying between an arc and a line.	Flow restrictor was created successfully at the selected arc. (Refer Table 4.6. Result ID 31)

<b>ID</b>	<b>Area</b>	<b>No.</b>	<b>Name</b>	<b>Routine Description</b>	<b>Possible Instances</b>	<b>Program Design Feature</b>	<b>Test Case</b>	<b>Result</b>
							(Refer Table 4.4. Test Case ID: P1E7cc)	
					d. The corner angle in acute.	Appropriate dimensions of the flow restrictor are calculated and is sketched	Test DXF file created containing a profile with an acute inner corner angle. (Refer Table 4.4. Test Case ID: P1E7d)	Flow restrictor was created successfully. (Refer Table 4.6. Result ID 32)
					e. The corner angle is obtuse.		Test DXF file containing a profile with an obtuse inner corner angle. (Refer Table 4.4. Test Case ID: P1E7e)	Flow restrictor was created successfully. (Refer Table 4.6. Result ID 33)
	Lead In And Tool path	8	Lead In	Based on the type of lead-in, determine the offset value and sketch the lead-in. In case of ball lead-in, additional toolpath for ball end mill will be generated.	a. If geometry contains a clockwise arc between two counterclockwise segments	Offset value will be calculated, lead-in will be sketched.	a. Ball lead-in is selected in the main extrusion tooling design form. (Refer Table 4.4. Test Case ID: P1F8a)	The program selected the right ball end mill diameter and the lead-in was designed properly. (Refer Table 4.6. Result ID 34)
					b. Chamfer lead-in is selected in the main extrusion tooling design form. (Refer Table 4.4. Test Case ID: P1F8a)		The program selected the right chamfer end mill tool and the lead-in was designed properly. (Refer Table 4.6. Result ID 35)	
					b. If the inner corner of the	Offset value will be calculated, lead-in will be sketched.	a. Ball lead-in is selected in the main extrusion	The program selected the right ball end mill diameter and the lead-in was

I D	A r e a	N o .	N a m e	Routine Description	Possible Instances	Program Design Feature	Test Case	Result
					profile has a small radius		tooling design form. (Refer Table 4.4. Test Case ID: P1F8b)	designed properly. (Refer Table 4.6. Result ID 36)
							b. Chamfer lead-in is selected in the main extrusion tooling design form. (Refer Table 4.4. Test Case ID: P1F8b)	The program selected the right chamfer end mill tool and the lead-in was designed properly. (Refer Table 4.6. Result ID 37)
					c. If the inner corner has a large radius	Offset value will be calculated, lead-in will be sketched.	a. Ball lead-in is selected in the main extrusion tooling design form. (Refer Table 4.4. Test Case ID: P1F8c)	The program selected the right ball end mill diameter and the lead-in was designed properly. (Refer Table 4.6. Result ID 38)
							b. Chamfer lead-in is selected in the main design form. (Refer Table 4.4. Test Case ID: P1F8c)	The program selected the right chamfer end mill tool and the lead-in was designed properly. (Refer Table 4.6. Result ID 39)
		9	Tool path	Offset the adjusted profile so that the final profile is 0.005in thick.  This is only performed if a ball lead-in is required for the die plate.	a. If geometry contains a clockwise arc between two counterclockwise segments	Offset value will be calculated and tool-path will be created.	a. Ball lead-in is selected in the main extrusion tooling design form. (Refer Table 4.4. Test Case ID: P1F8a)	The toolpath was designed properly. (Refer Table 4.6. Result ID 40)
							b. Chamfer lead-in is selected in the main extrusion	The toolpath was not designed since it is only created for ball lead-in.

<b>ID</b>	<b>Area</b>	<b>No.</b>	<b>Name</b>	<b>Routine Description</b>	<b>Possible Instances</b>	<b>Program Design Feature</b>	<b>Test Case</b>	<b>Result</b>
							tooling design form. (Refer Table 4.4. Test Case ID: P1F8a)	
					b. If the inner corner of the profile has a small radius,	Offset value will be calculated and tool-path will be created.	Ball lead-in is selected in the main extrusion tooling design form. (Refer Table 4.4. Test Case ID: P1F8b)	The toolpath was designed properly. (Refer Table 4.6. Result ID 41)
					c. If the inner corner of the profile has a large radius.		Ball lead-in is selected in the main extrusion tooling design form. (Refer Table 4.4. Test Case ID: P1F8c)	The toolpath was designed properly. (Refer Table 4.6. Result ID 42)
G	Transition Plate Profile	10	Transition Plate No	Transition zone is calculated and the total thickness is used to determine the number of plates in transition zone.	a. The transition zone thickness has been calculated to be greater than 4 inches.	The program will fail since a transition zone greater than 4 inches will require more than 2 plates which is currently out of scope.	If the profile is selected to have a length of 10 inches, wall thickness of 1 inch and a wire cutting angle of 25 degrees, then the transition zone thickness will be greater than 4 inches. (Refer Table 4.4. Test Case ID: P1G10a)	Return a message to the user that the current set of values is not supported. (Refer Table 4.6. Result ID 43)
					b. The transition zone thickness is between 2 and 4 inches.	The routine will execute modelling two transition plates.	If the profile is selected to have a length of 5 inches, wall thickness of 1 inch and a wire cutting angle of 19 degrees, the	The routine will create planes representing the two transition plates. Both the plates will have the same thickness. (Refer Table 4.6. Result ID 44)

I D	A r e a	N o .	N a m e	R o u t i n e  D e s c r i p t i o n	P o s s i b l e  I n s t a n c e s	P r o g r a m  D e s i g n  F e a t u r e	T e s t  C a s e	R e s u l t
							transition zone thickness will be 2.25 inches. (Refer Table 4.4. Test Case ID: P1G10b)	
					c. Transition zone thickness is calculated to be less than 2 inches.	The routine will create single transition plate profiles.	If the profile is selected to have a length of 5 inches, wall thickness of 1 inch and a wire cutting angle of 25 degrees, the transition zone thickness will be 1.5inches. (Refer Table 4.4. Test Case ID: P1G10c)	The routine will create planes to represent a single transition plate with the plate thickness same as transition zone thickness. (Refer Table 4.6. Result ID 45)
		1	T r a n s i t i o n	Transition zone is calculated and the outlet profile is placed accordingly. In case there are two transition plates, there will be two transition outlet profiles.	a. Case where there is only one transition plate.	The transition outlet profile will be the same as the lead-in on the die inlet.	If the profile is selected to have a length of 5 inches, wall thickness of 1 inch and a wire cutting angle of 25 degrees, the transition zone thickness will be 1.5inches. Since the total transition zone is less than 2 inches, there will be only a single transition plate. (Refer Table 4.4. Test Case ID: P1G10c)	The routine will use convert entities tool to make the trans outlet profile the same as the lead-in profile on the die inlet. (Refer Table 4.6. Result ID 46)
					b. Case where there are two transition plates.	The first transition plate will have the same outlet profile as the	If the profile is selected to have a length of 5 inches, wall thickness of 1	The first transition plate will have the same outlet profile as the lead-in on the die inlet profile.



I D	A r e a	N o .	N a m e	R o u t i n e D e s c r i p t i o n	P o s s i b l e I n s t a n c e s	P r o g r a m D e s i g n F e a t u r e	T e s t C a s e	R e s u l t
						<p>lead-in on the die inlet profile.</p> <p>The outlet profile of the second transition plate will be an offset of the die lead-in profile</p>	<p>inch and a wire cutting angle of 19 degrees, the transition zone thickness will be 2.25 inches. Since the value of Transition zone thickness is greater than 2 and less than 4, the program will create two transition plates. (Refer Table 4.4. Test Case ID: P1G10b)</p>	<p>The outlet profile of the second transition plate will be designed such that it creates an intermediary profile between the transition and the adapter profile. (Refer Table 4.6. Result ID 47)</p>
		1 2	T r a n s I n l e t	<p>Transition plate thickness is determined and the transition inlet profile is placed.</p>	<p>a. Case where there is only one transition plate.</p>	<p>The inlet profile of the transition plate will be the same as the outlet profile of the adapter plate.</p>	<p>If the profile is selected to have a length of 5 inches, wall thickness of 1 inch and a wire cutting angle of 25 degrees, the transition zone thickness will be 1.5inches. Since the total transition zone is less than 2 inches, there will be only a single transition plate. (Refer Table 4.4. Test Case ID: P1G10c)</p>	<p>The inlet profile of the transition plate will be the same as the outlet profile of the adapter plate. (Refer Table 4.6. Result ID 48)</p>
					<p>b. Case where there are two transition plates.</p>	<p>In this case, the inlet profile on the first transition plate will be an offset of the die lead-in profile. The inlet profile on the second</p>	<p>If the profile is selected to have a length of 5 inches, wall thickness of 1 inch and a wire cutting angle of 19 degrees, the transition zone</p>	<p>In this case, the inlet profile on the first transition plate will be an offset of the die lead-in profile. The inlet profile on the second transition plate will be the same as the outlet</p>

<b>ID</b>	<b>Area</b>	<b>No.</b>	<b>Name</b>	<b>Routine Description</b>	<b>Possible Instances</b>	<b>Program Design Feature</b>	<b>Test Case</b>	<b>Result</b>
						transition plate will be the same as the outlet on the adapter plate.	thickness will be 2.25 inches. Since the value of Transition zone thickness is greater than 2 and less than 4, the program will create two transition plates. (Refer Table 4.4. Test Case ID: P1G10b)	on the adapter plate. (Refer Table 4.6, Result ID 49)
H	Adapter Plate Profile	13	Adapter Outlet	The outlet adapter profile can either be a generic shape or a custom offset of the profile. The size of the generic shape and offset is determined by the customer and by default depends on the size of the lead-in profile.	a. Round generic shape is chosen for Adapter Outlet.	The routine will ask for choice of generic shape and dimensions. If no dimensions are supplied, the default values are determined and used.	Round generic shape is chosen for Adapter Outlet. (Refer Table 4.4. Test Case ID: P1G10c)	A round profile was created at the adapter outlet. (Refer Table 4.6, Result ID 50)
					b. Rectangle generic shape is chosen for Adapter Outlet.		Rectangle generic shape is chosen for Adapter Outlet. (Refer Table 4.4. Test Case ID: P1G10c)	A rectangular profile was created at the adapter outlet. (Refer Table 4.6, Result ID 51)
					d. Hourglass shape is chosen for Adapter Outlet.		Hourglass shape is chosen for Adapter Outlet. (Refer Table 4.4. Test Case ID: P1G10c)	An hourglass profile was created at the adapter outlet. (Refer Table 4.6, Result ID 52)
					e. Pill or Slot shape is chosen for Adapter Outlet.		Pill or Slot shape is chosen for Adapter Outlet. (Refer Table 4.4. Test Case ID: P1G10c)	A slot profile was created at the adapter outlet. (Refer Table 4.6, Result ID 53)

## APPENDIX B

### EXPERT SYSTEM SOURCE CODE

Table B.1 consists of all the routines used along with public links to the source code for each routine.

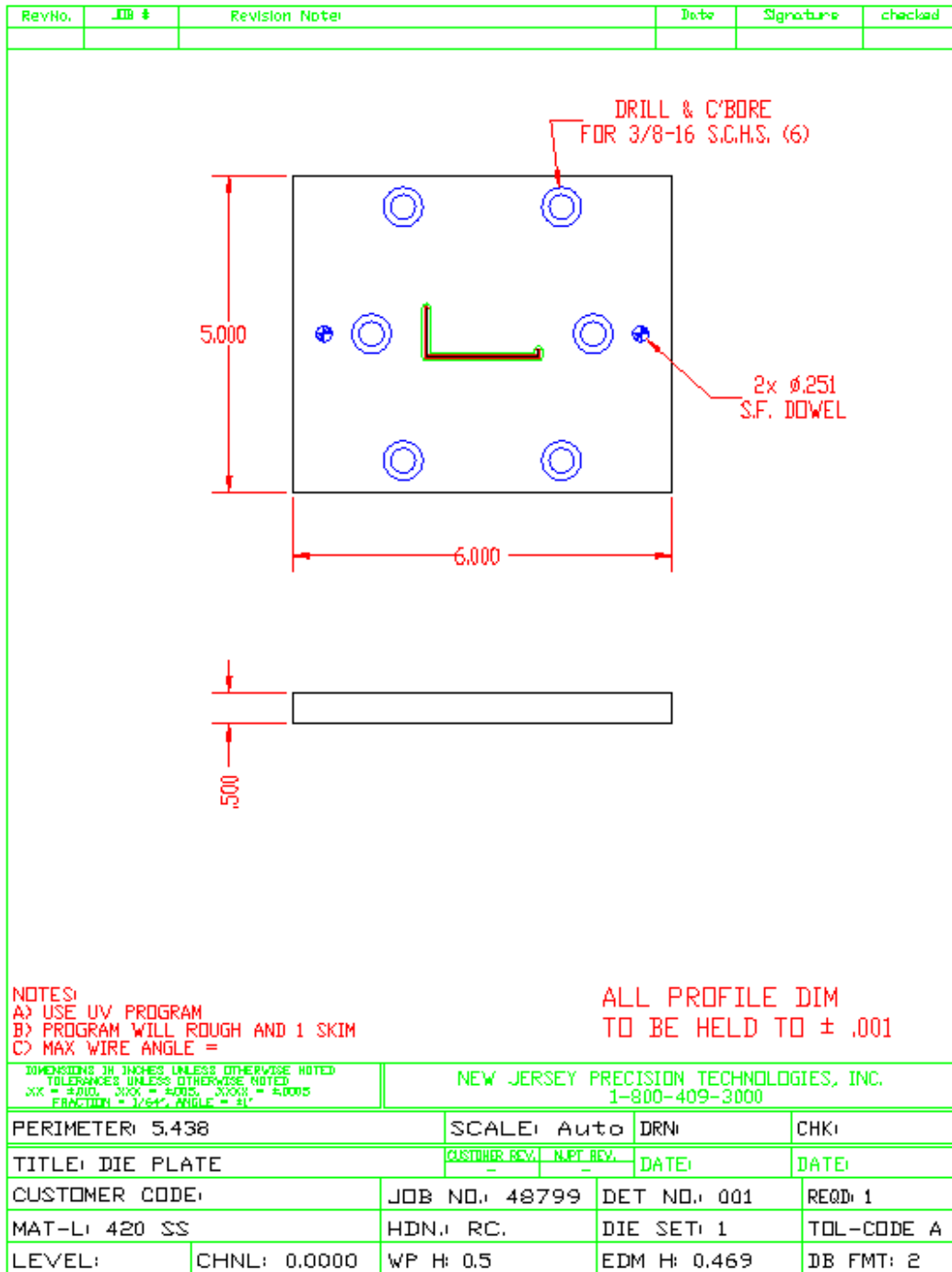
**Table B.1** Source Code Links for all the Routines Involved in the Expert System

Routine Name	Link to Source Code
ExtToolMain	<a href="https://drive.google.com/open?id=113DLPWGI3G5RtHNjIFkca_-2o6UpFewz">https://drive.google.com/open?id=113DLPWGI3G5RtHNjIFkca_-2o6UpFewz</a>
DXFImport	<a href="https://drive.google.com/open?id=1aCA8IvVQU2MFPEIMeaBKKtGoiVNYWToA">https://drive.google.com/open?id=1aCA8IvVQU2MFPEIMeaBKKtGoiVNYWToA</a>
PolygonFix	<a href="https://drive.google.com/open?id=1SIKqp-RevQ8_gvNlzZs_Nd2sUNM8CKLP">https://drive.google.com/open?id=1SIKqp-RevQ8_gvNlzZs_Nd2sUNM8CKLP</a>
TrueCenter	<a href="https://drive.google.com/open?id=1f8y2inVrVFOcvODfp1t2L6fn5EQThXHd">https://drive.google.com/open?id=1f8y2inVrVFOcvODfp1t2L6fn5EQThXHd</a>
profScaleDDA	<a href="https://drive.google.com/open?id=1vAtl6_UWCI_nx65UXjUgnE_AMojoyFSAh">https://drive.google.com/open?id=1vAtl6_UWCI_nx65UXjUgnE_AMojoyFSAh</a>
profWTAdj	<a href="https://drive.google.com/open?id=1bUZT62nmxf_JhhR6w5a3xf7SM9_FsSD">https://drive.google.com/open?id=1bUZT62nmxf_JhhR6w5a3xf7SM9_FsSD</a>
LegMod	<a href="https://drive.google.com/open?id=1pLeFAAwBhtNbv3A77js1_1qhtYCzdOs">https://drive.google.com/open?id=1pLeFAAwBhtNbv3A77js1_1qhtYCzdOs</a>
FlowRestrictor	<a href="https://drive.google.com/open?id=1cwpnuP562yjqvx_zM3m4wriRQzw_Hh8F">https://drive.google.com/open?id=1cwpnuP562yjqvx_zM3m4wriRQzw_Hh8F</a>
LeadIn	<a href="https://drive.google.com/open?id=1MVuQ5zr1DJMoWQ1YOh-JoiIFqj82wV7o">https://drive.google.com/open?id=1MVuQ5zr1DJMoWQ1YOh-JoiIFqj82wV7o</a>
ToolPath	<a href="https://drive.google.com/open?id=1RIEDMhtGq5WCoTUusyX-8n_2RDs6nxZMu">https://drive.google.com/open?id=1RIEDMhtGq5WCoTUusyX-8n_2RDs6nxZMu</a>
Trans1Outlet	<a href="https://drive.google.com/open?id=1tduYjASgPUDqS1YuTye4ayOgWW1w_v82">https://drive.google.com/open?id=1tduYjASgPUDqS1YuTye4ayOgWW1w_v82</a>
TransPlateNo	<a href="https://drive.google.com/open?id=1Q7W7r4WSZynnvCVIdb8K_GShB-O2cd4P">https://drive.google.com/open?id=1Q7W7r4WSZynnvCVIdb8K_GShB-O2cd4P</a>
AdapInlet	<a href="https://drive.google.com/open?id=1MPalIzrThsRUDIY5lwb-jCGDKnvTMP6K">https://drive.google.com/open?id=1MPalIzrThsRUDIY5lwb-jCGDKnvTMP6K</a>
AdapOutlet	<a href="https://drive.google.com/open?id=1ZIVzXXT8Oube2gbXLLvZvMqjr5jFba9J">https://drive.google.com/open?id=1ZIVzXXT8Oube2gbXLLvZvMqjr5jFba9J</a>
Trans2Inlet	<a href="https://drive.google.com/open?id=1mWBzAjtLrPLBmVxcW11oW6-4RTPg4XGs">https://drive.google.com/open?id=1mWBzAjtLrPLBmVxcW11oW6-4RTPg4XGs</a>
Trans2Outlet	<a href="https://drive.google.com/open?id=1qj0qABzZncAM6GDPztaif-a1mctSg-Cd">https://drive.google.com/open?id=1qj0qABzZncAM6GDPztaif-a1mctSg-Cd</a>
Trans1Inlet	<a href="https://drive.google.com/open?id=1sNx7BYWyyvqTj-AKrcxp2mNZli7UIhKmx">https://drive.google.com/open?id=1sNx7BYWyyvqTj-AKrcxp2mNZli7UIhKmx</a>
DieBlank	<a href="https://drive.google.com/open?id=1WJOzuGqiHR6bOOFBDDXmM53BpleLAGMT">https://drive.google.com/open?id=1WJOzuGqiHR6bOOFBDDXmM53BpleLAGMT</a>
TransBlank	<a href="https://drive.google.com/open?id=1kUzTEF2_7pzwF3m9p7-VPzIKUdqfMZm">https://drive.google.com/open?id=1kUzTEF2_7pzwF3m9p7-VPzIKUdqfMZm</a>
AdapBlank	<a href="https://drive.google.com/open?id=1nEnaLj0hDFU06qighI_sOy_2IpgZqbg2">https://drive.google.com/open?id=1nEnaLj0hDFU06qighI_sOy_2IpgZqbg2</a>
AdapHoles	<a href="https://drive.google.com/open?id=1GMifL4UAbuw_VyZVnWdVSFIUaNfsJ6bd">https://drive.google.com/open?id=1GMifL4UAbuw_VyZVnWdVSFIUaNfsJ6bd</a>
TransHoles	<a href="https://drive.google.com/open?id=1Zy5TZbLXQZa-Yiqednn53nKS-hocdUuF">https://drive.google.com/open?id=1Zy5TZbLXQZa-Yiqednn53nKS-hocdUuF</a>
DieHoles	<a href="https://drive.google.com/open?id=1FVbnoJMjpl2NB1A9NIPXX278pmMDFir">https://drive.google.com/open?id=1FVbnoJMjpl2NB1A9NIPXX278pmMDFir</a>
DowelH	<a href="https://drive.google.com/open?id=1bLAtm2JXmguknTAP37l_Ps2G_abM5uiz">https://drive.google.com/open?id=1bLAtm2JXmguknTAP37l_Ps2G_abM5uiz</a>
DwgPrep	<a href="https://drive.google.com/open?id=1rhE2j5Fn9tVeSJWQmZSsz_86nl7CEils">https://drive.google.com/open?id=1rhE2j5Fn9tVeSJWQmZSsz_86nl7CEils</a>
DwgDie	<a href="https://drive.google.com/open?id=1ShJzededqhp3LLeSuvaY-1MLbgKdn8gF">https://drive.google.com/open?id=1ShJzededqhp3LLeSuvaY-1MLbgKdn8gF</a>
DwgTrans	<a href="https://drive.google.com/open?id=1-ndbQIzRUCH7ffSDgaS3bofzEGv0FHk7">https://drive.google.com/open?id=1-ndbQIzRUCH7ffSDgaS3bofzEGv0FHk7</a>
DwgTrans2	<a href="https://drive.google.com/open?id=1kq0Y1T1sqyMF7CJ95GbAkq9yXRVeYF3H">https://drive.google.com/open?id=1kq0Y1T1sqyMF7CJ95GbAkq9yXRVeYF3H</a>
DwgAdap	<a href="https://drive.google.com/open?id=1KOq242V4i-nxZt05jygccOMLVb-vbpPA">https://drive.google.com/open?id=1KOq242V4i-nxZt05jygccOMLVb-vbpPA</a>

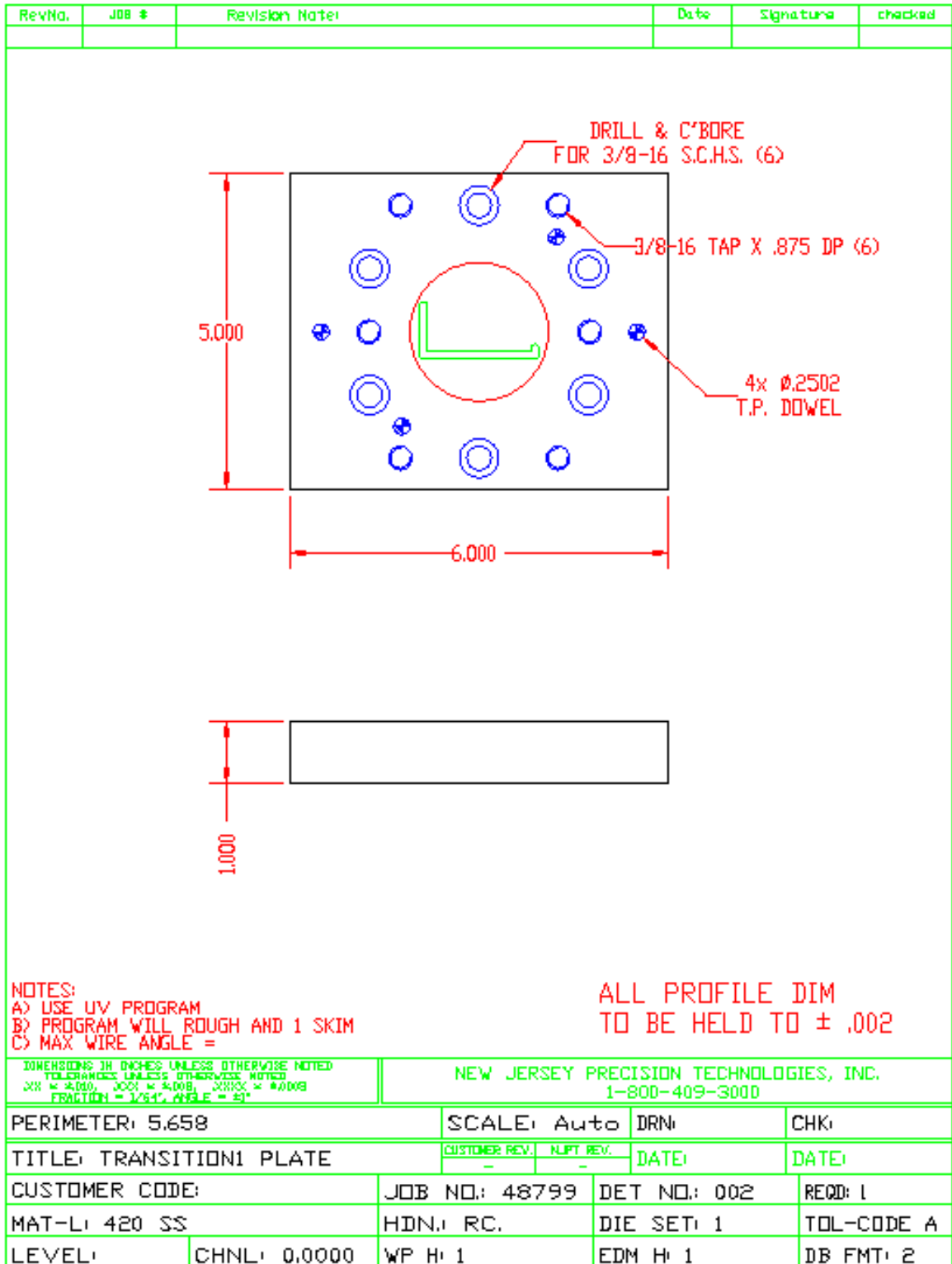
## APPENDIX C

### DRAWING SHEETS GENERATED BY EXPERT SYSTEM

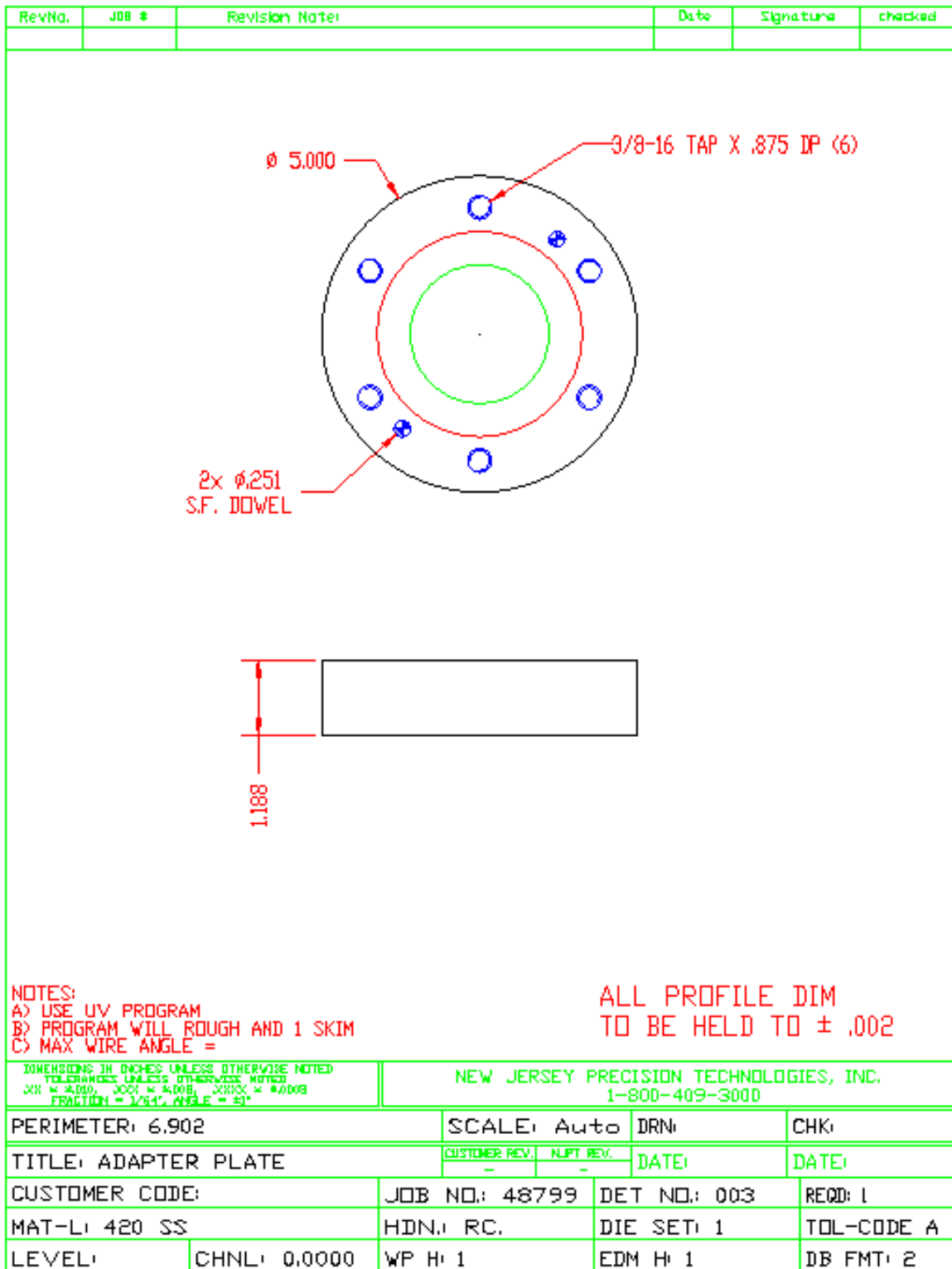
Figures C.1 to C.19 shows drawing sheets generated for the test cases listed in Table 4.5.



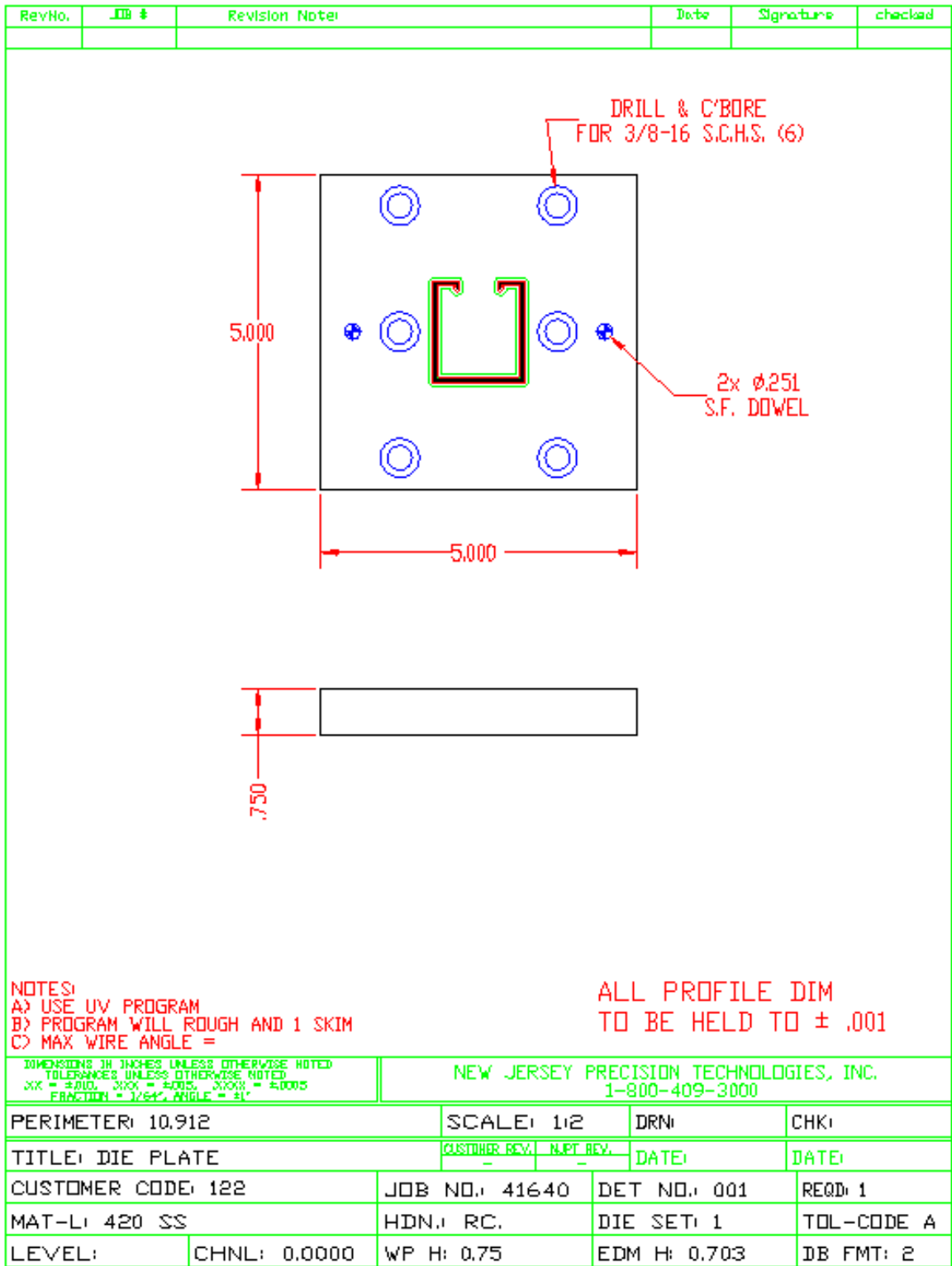
**Figure C.1** Drawing sheet generated for Job 48799 depicting Die plate.



**Figure C.2** Drawing sheet generated for Job 48799 depicting Transition 1 plate.



**Figure C.3** Drawing sheet generated for Job 48799 depicting Adapter plate.



**Figure C.4** Drawing sheet generated for Job 41640 depicting Die plate.

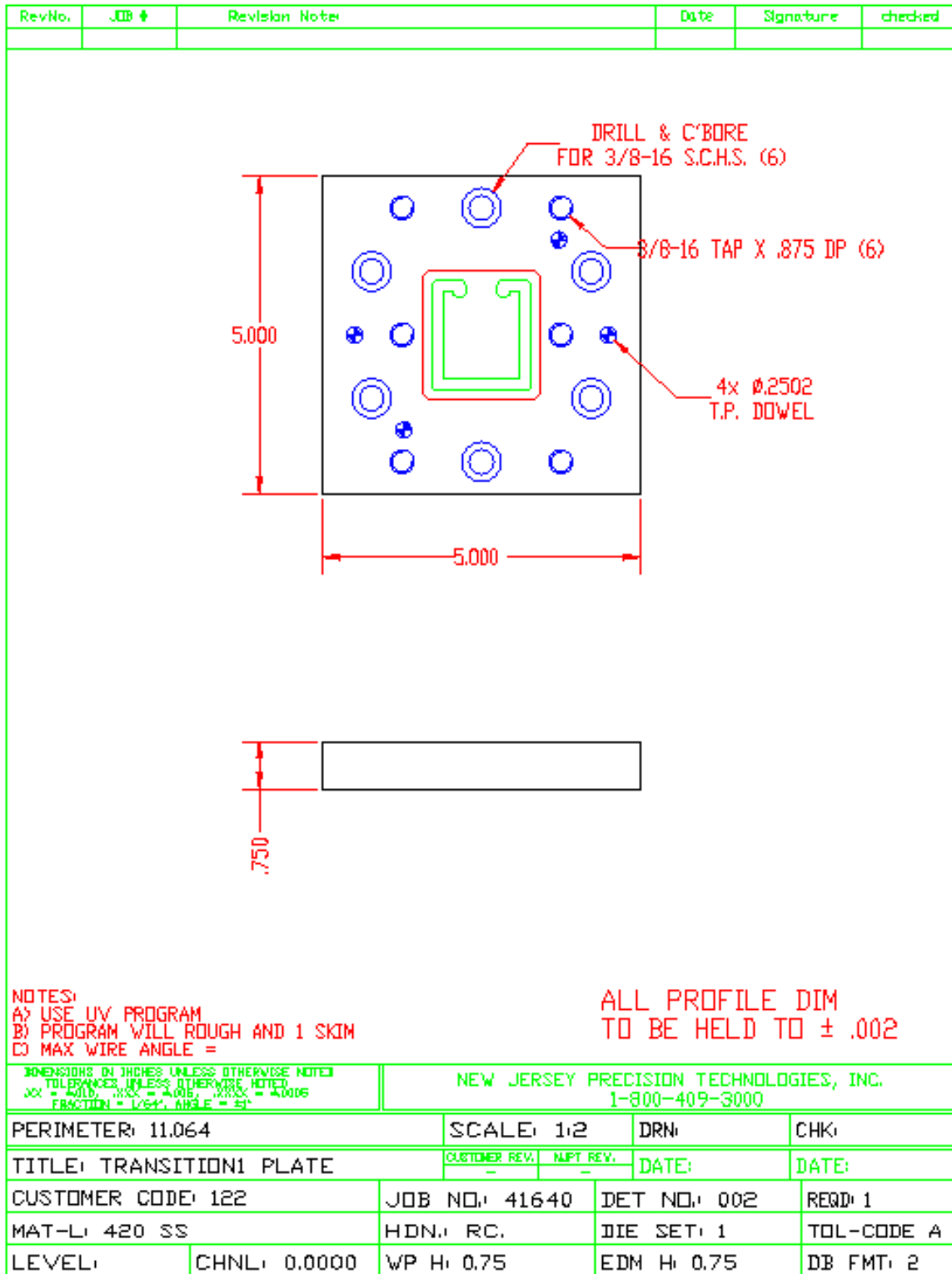


Figure C.5 Drawing sheet generated for Job 41640 depicting Transition 1 plate.



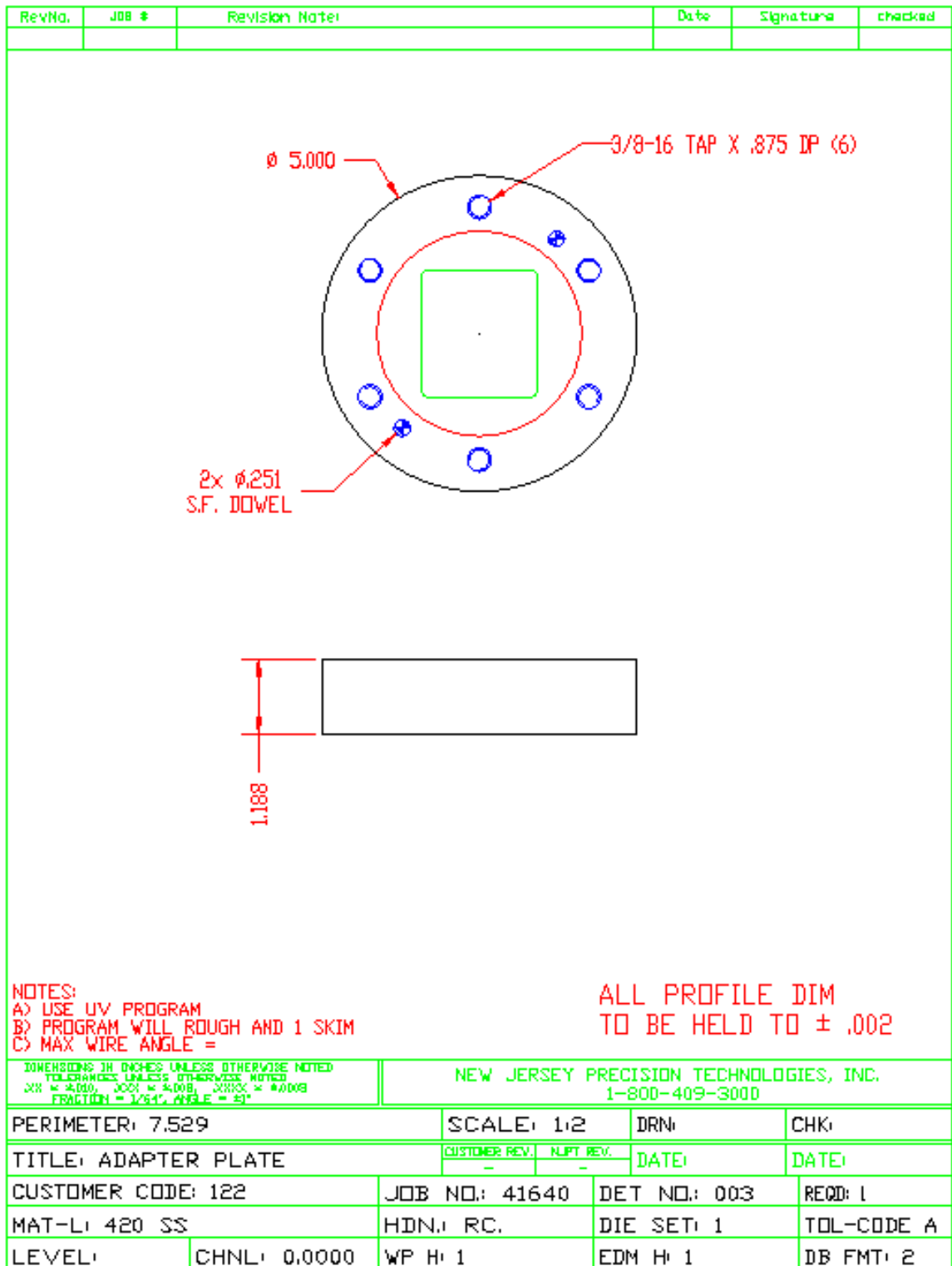


Figure C.6 Drawing sheet generated for Job 41640 depicting Adapter plate.

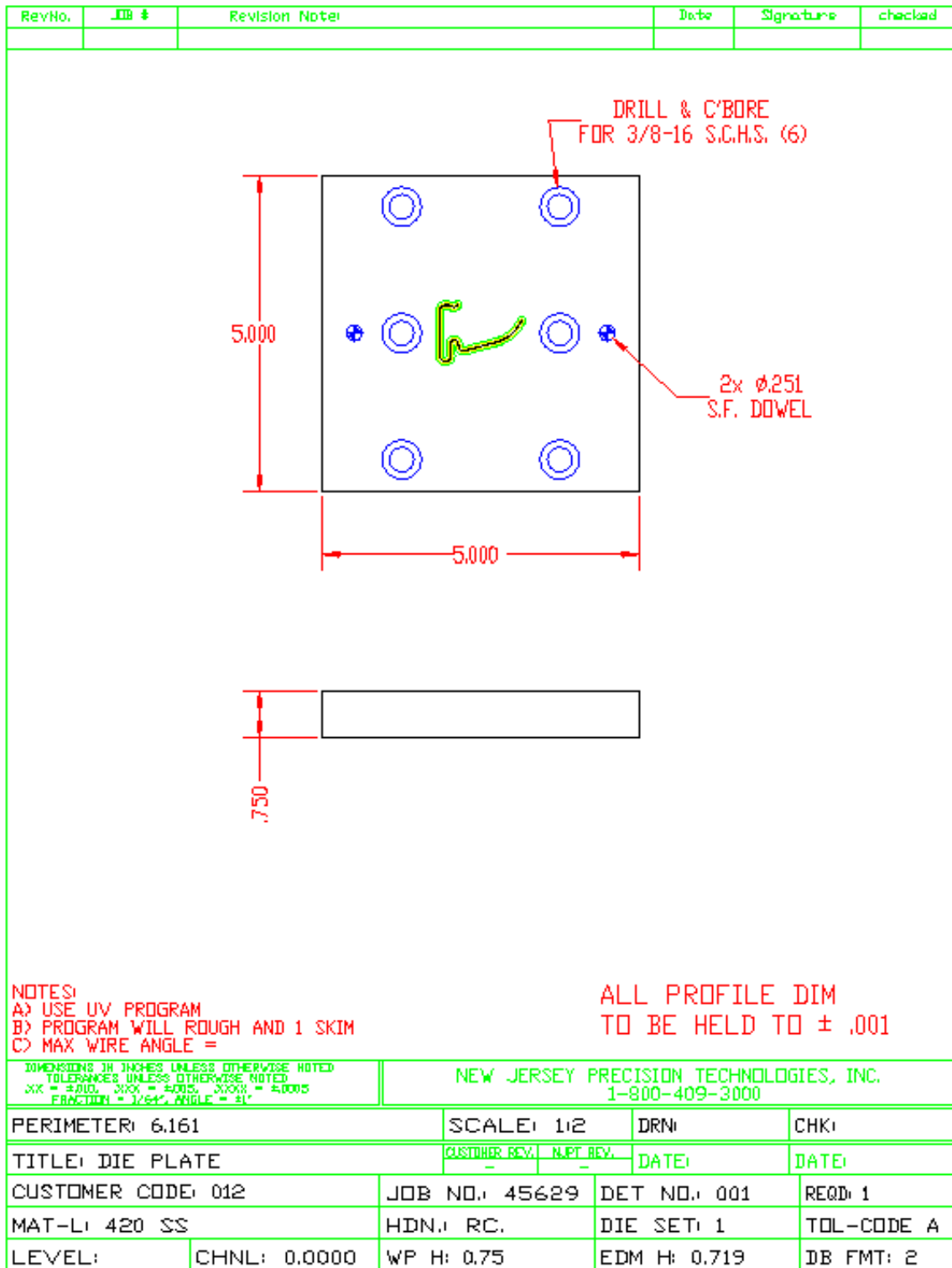


Figure C.7 Drawing sheet generated for Job 45629 depicting Die plate.

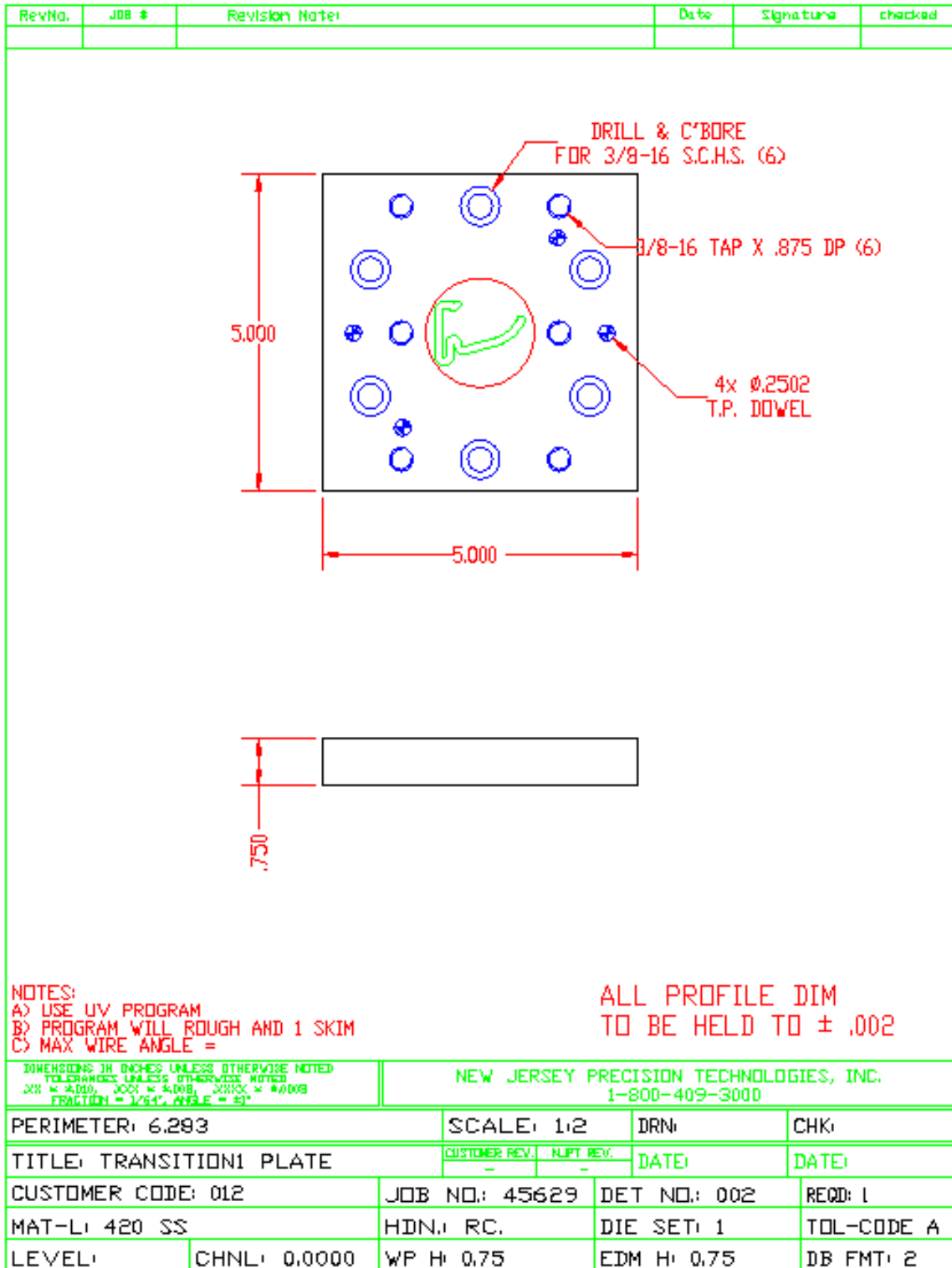
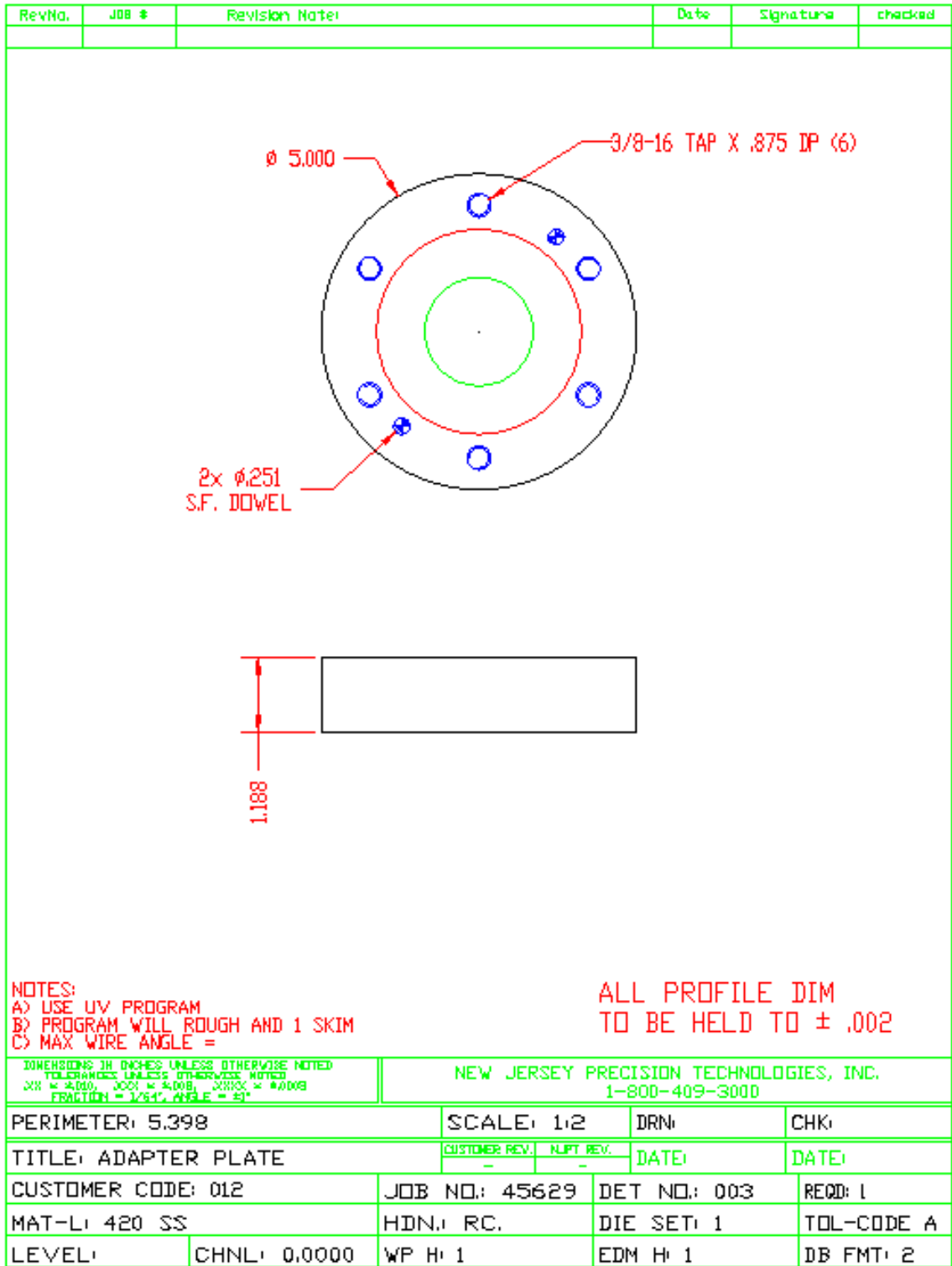


Figure C.8 Drawing sheet generated for Job 45629 depicting Transition 1 plate.



**Figure C.9** Drawing sheet generated for Job 45629 depicting Adapter plate.

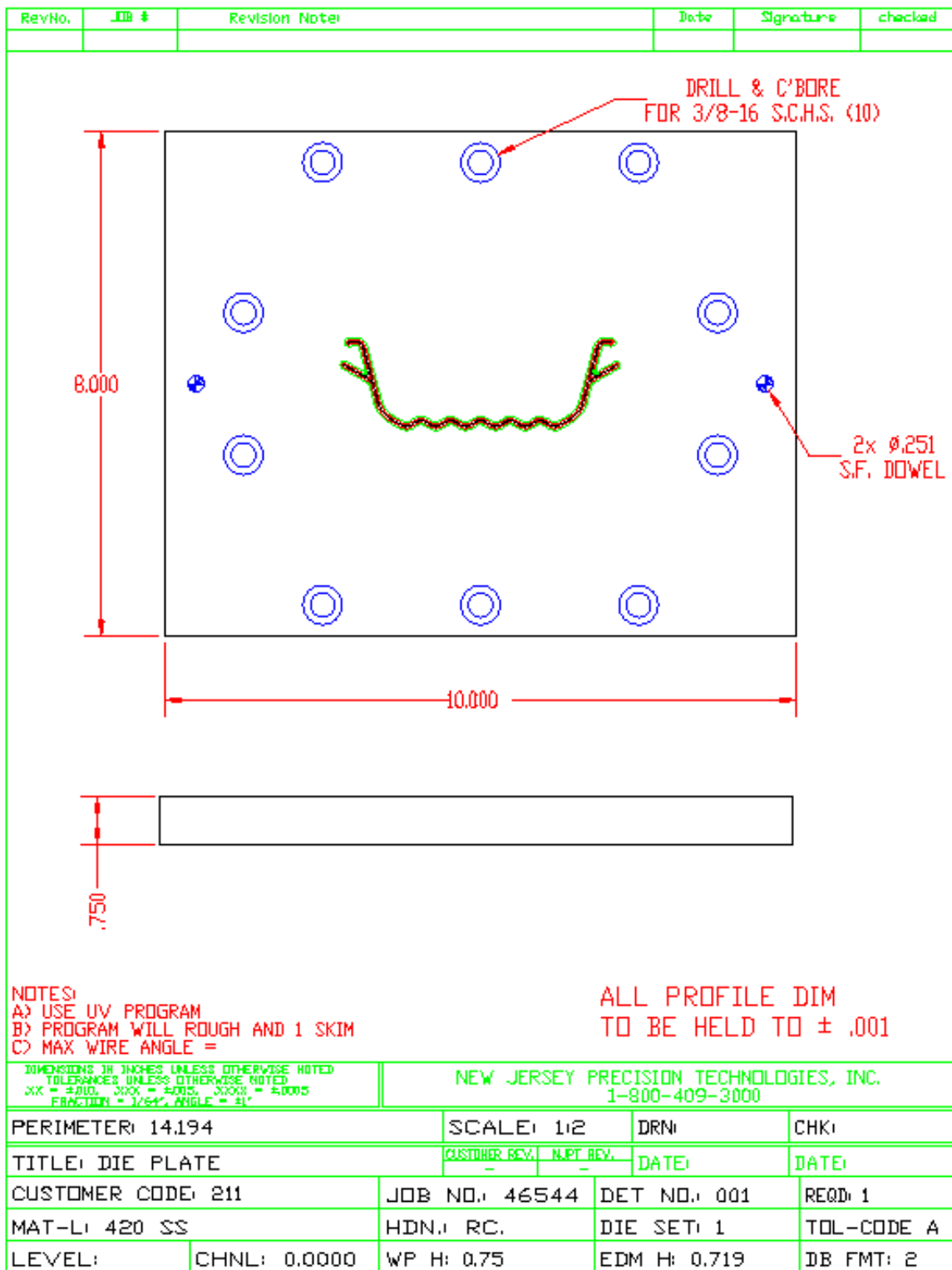
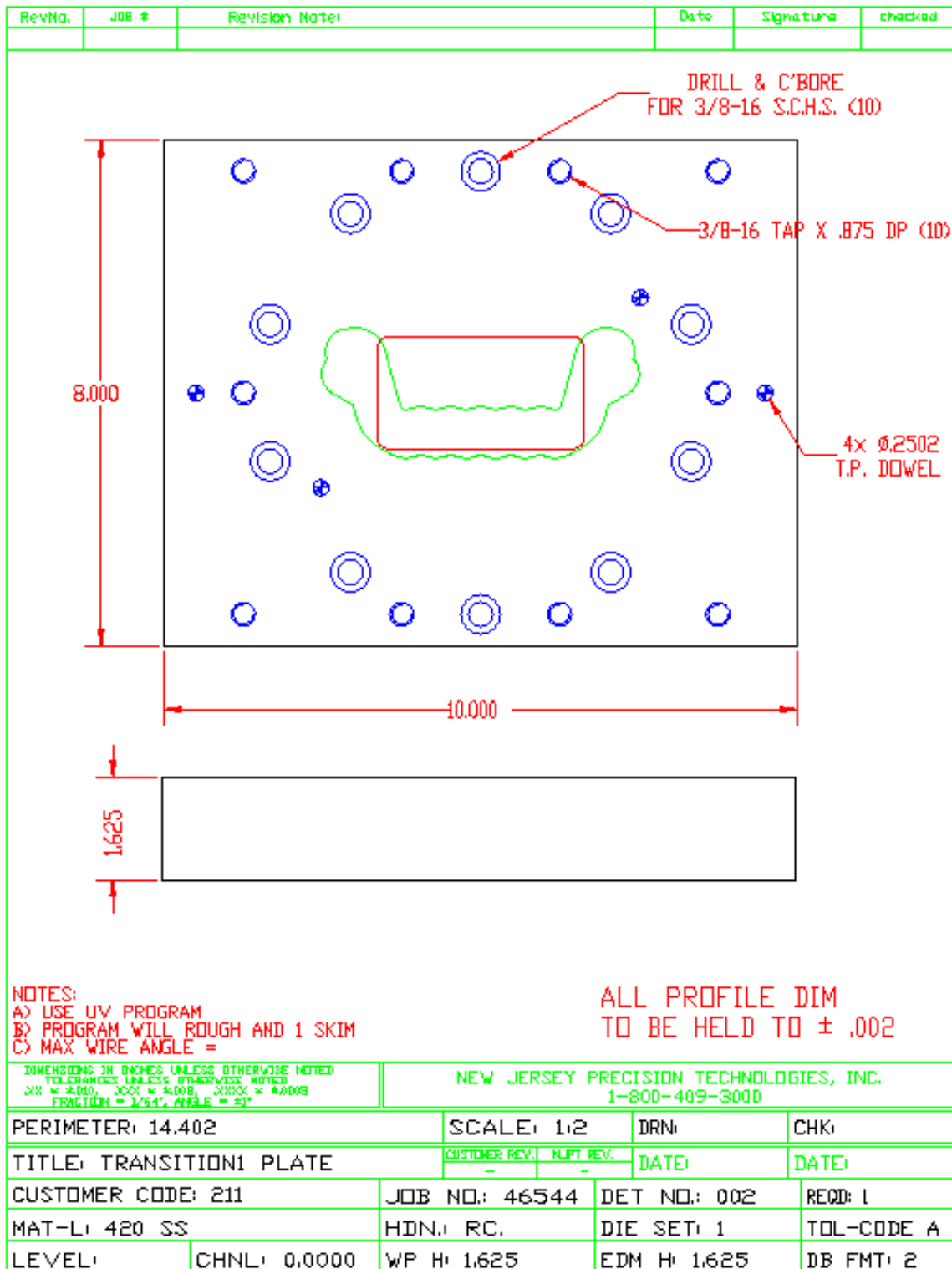


Figure C.10 Drawing sheet generated for Job 46544 depicting Die plate.



**Figure C.11** Drawing sheet generated for Job 46544 depicting Transition 1 plate.

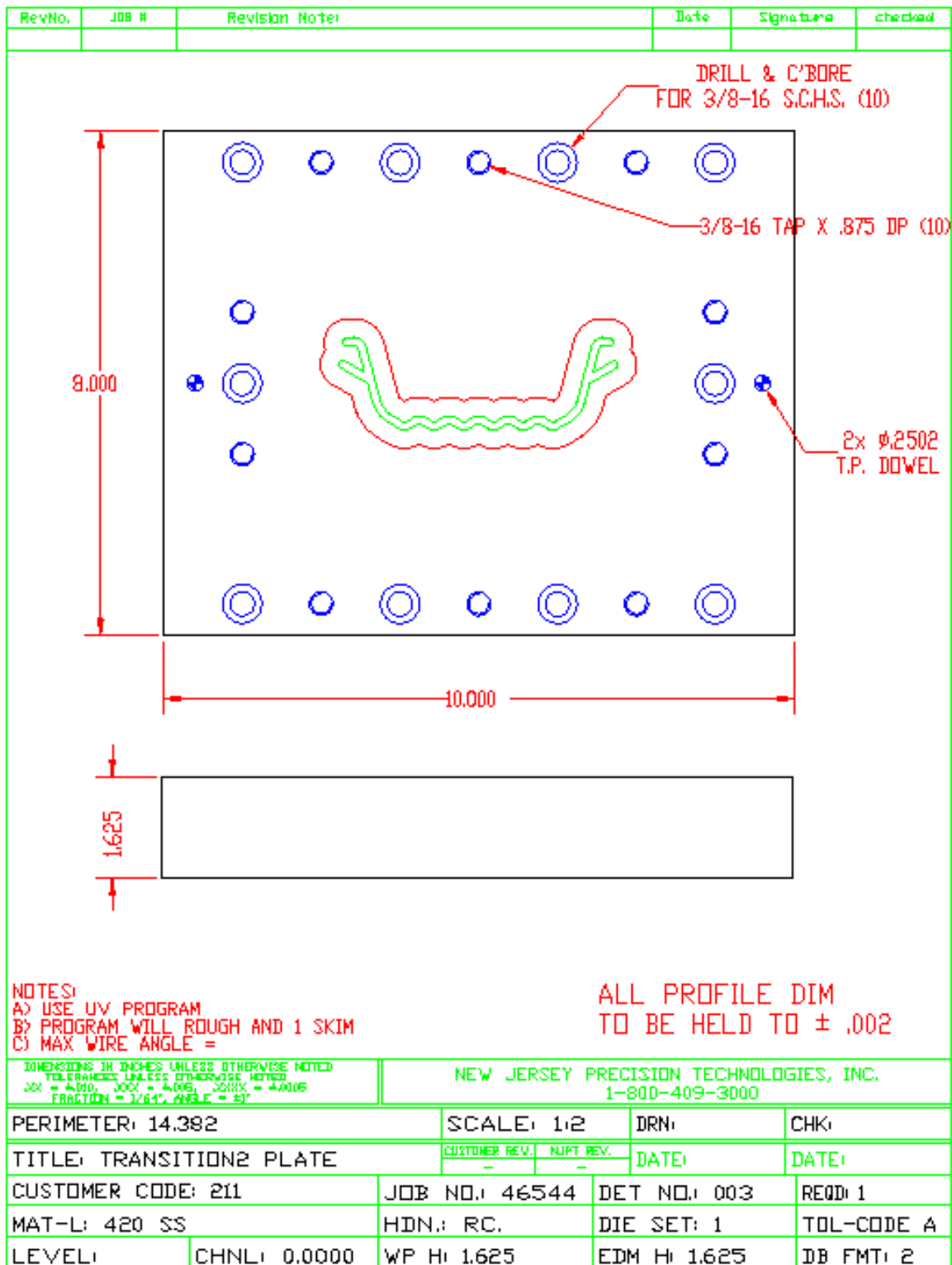
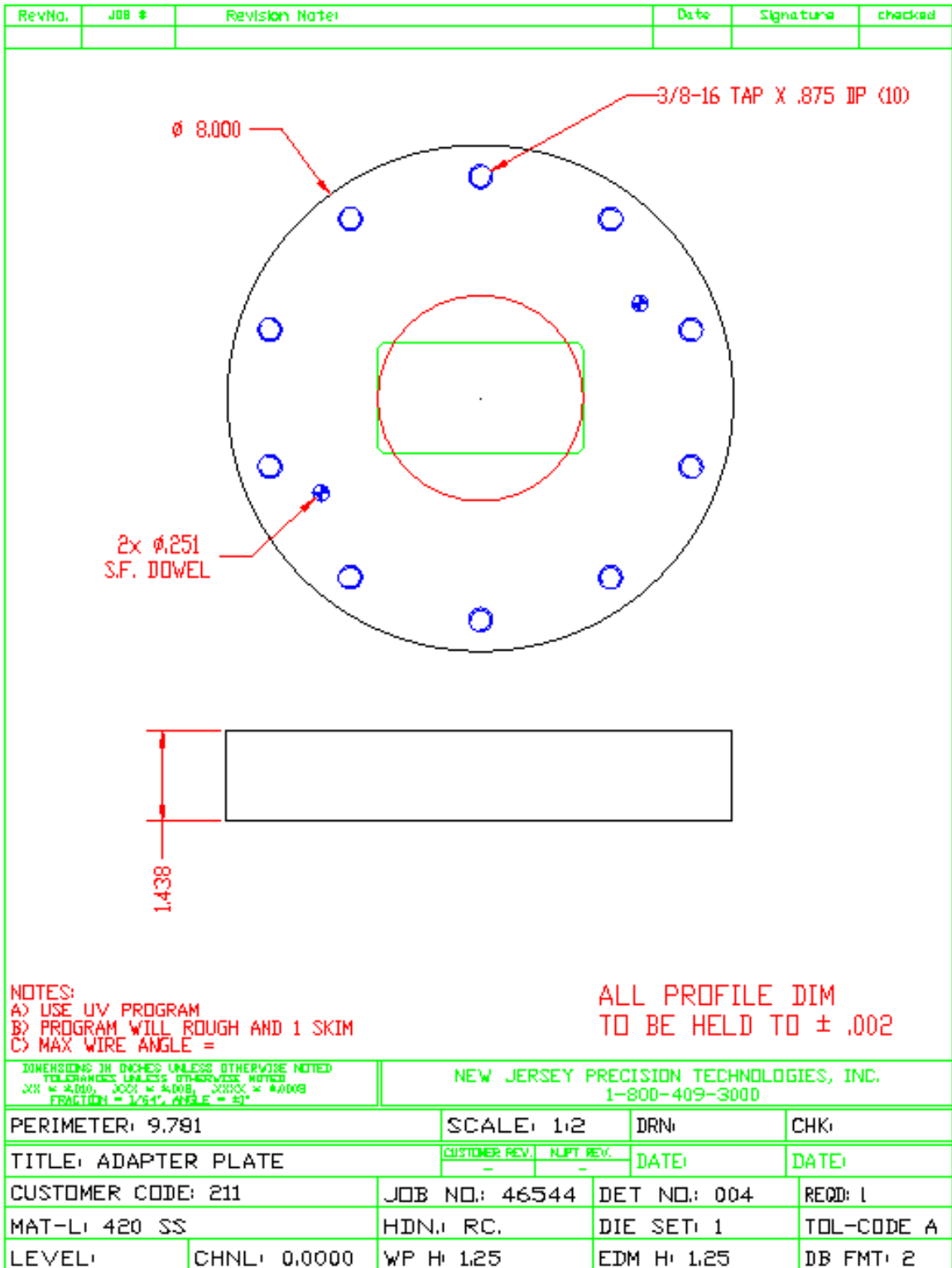


Figure C.12 Drawing sheet generated for Job 46544 depicting Transition 2 plate.



**Figure C.13** Drawing sheet generated for Job 46544 depicting Adapter plate.



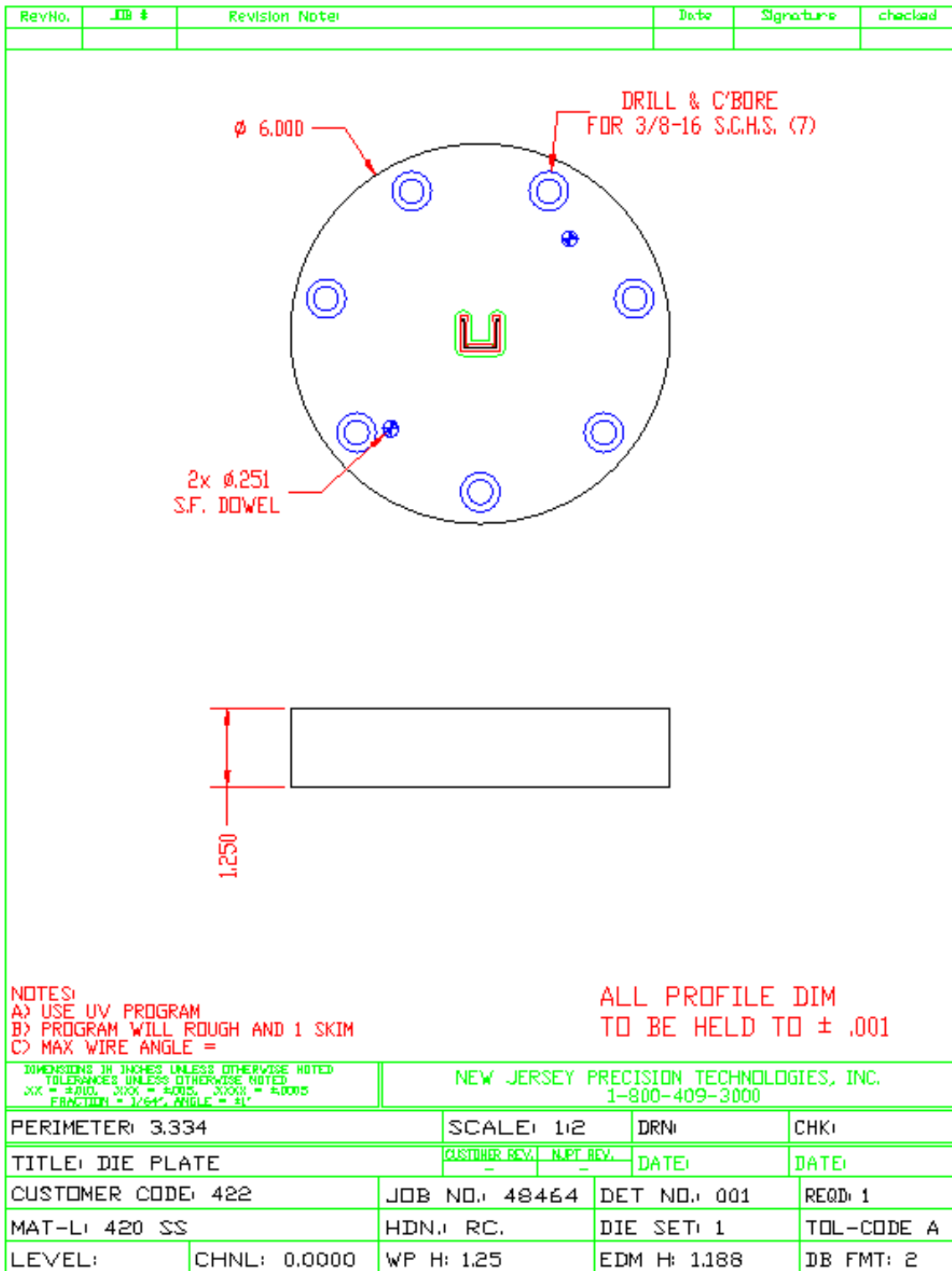
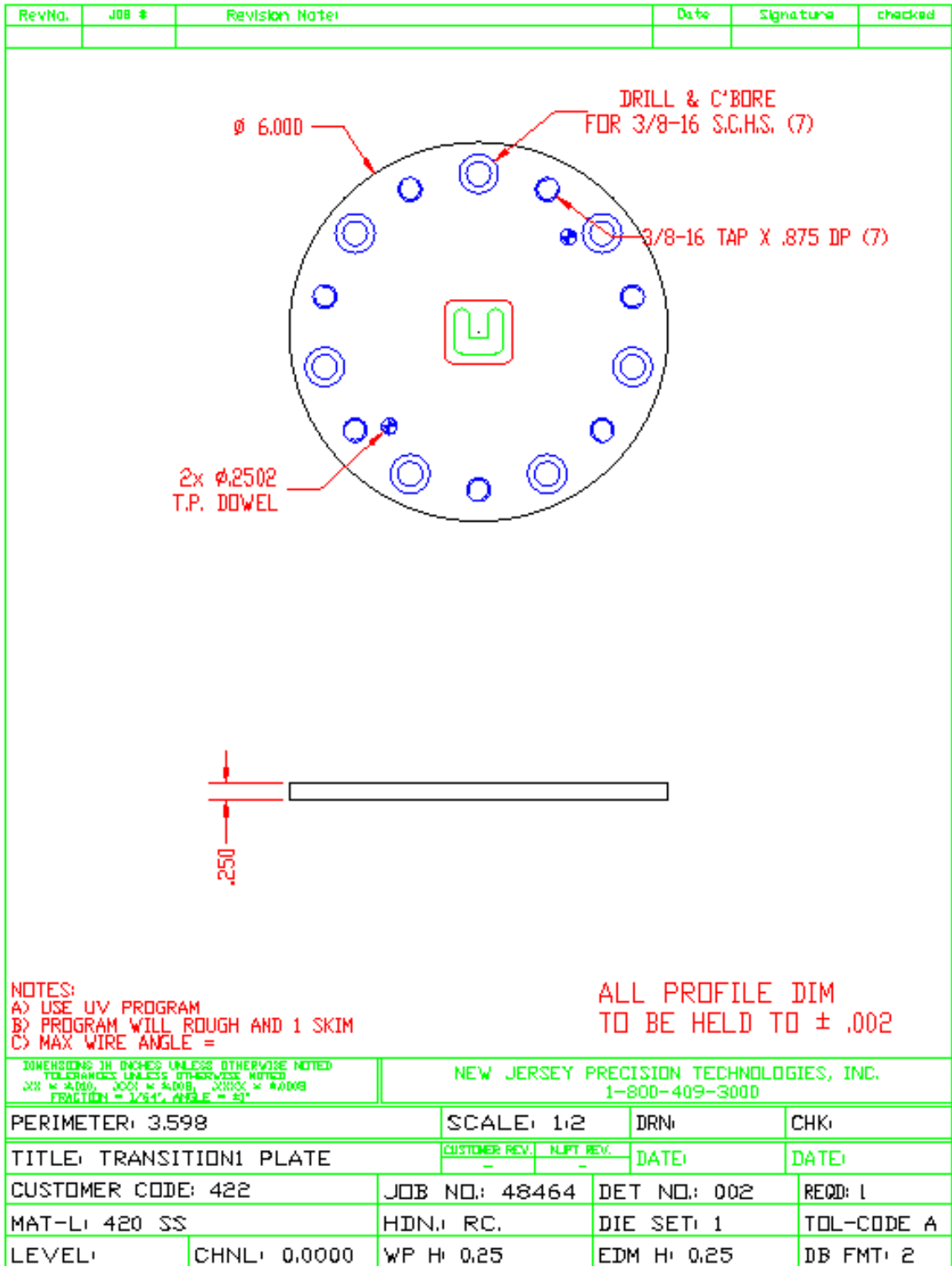


Figure C.14 Drawing sheet generated for Job 48464 depicting Die plate.



**Figure C.15** Drawing sheet generated for Job 48464 depicting Transition 1 plate.

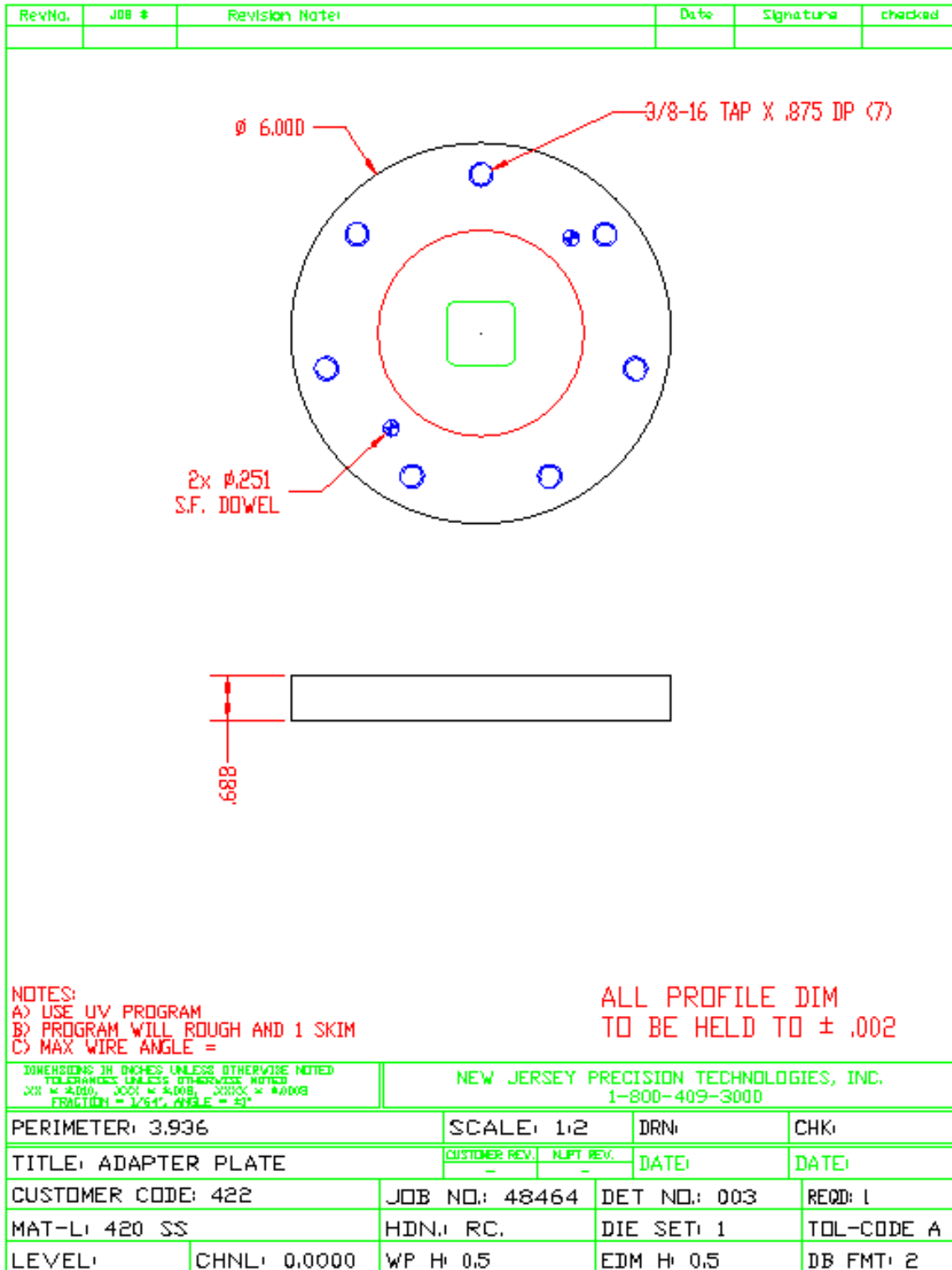


Figure C.16 Drawing sheet generated for Job 48464 depicting Adapter plate.

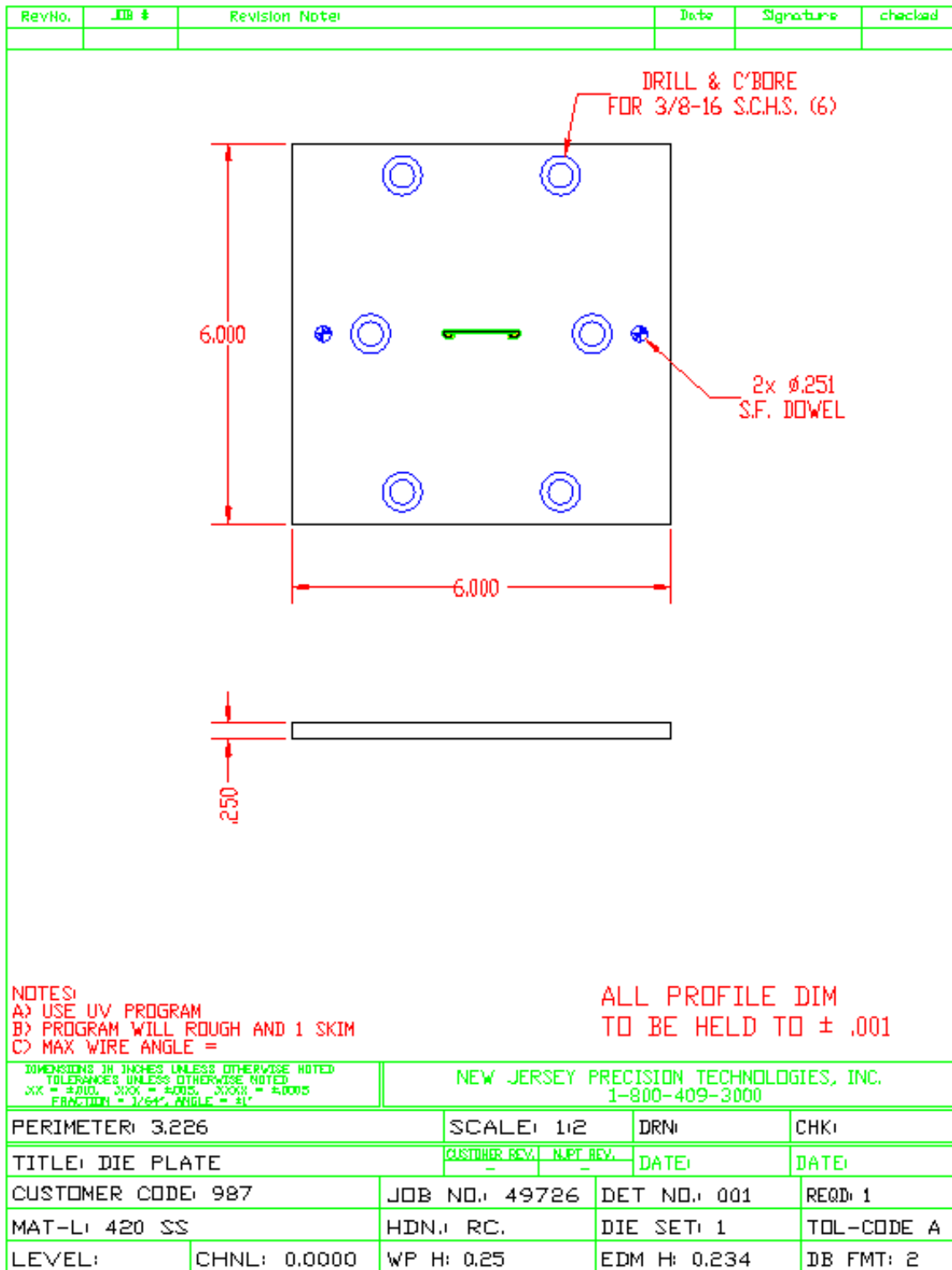
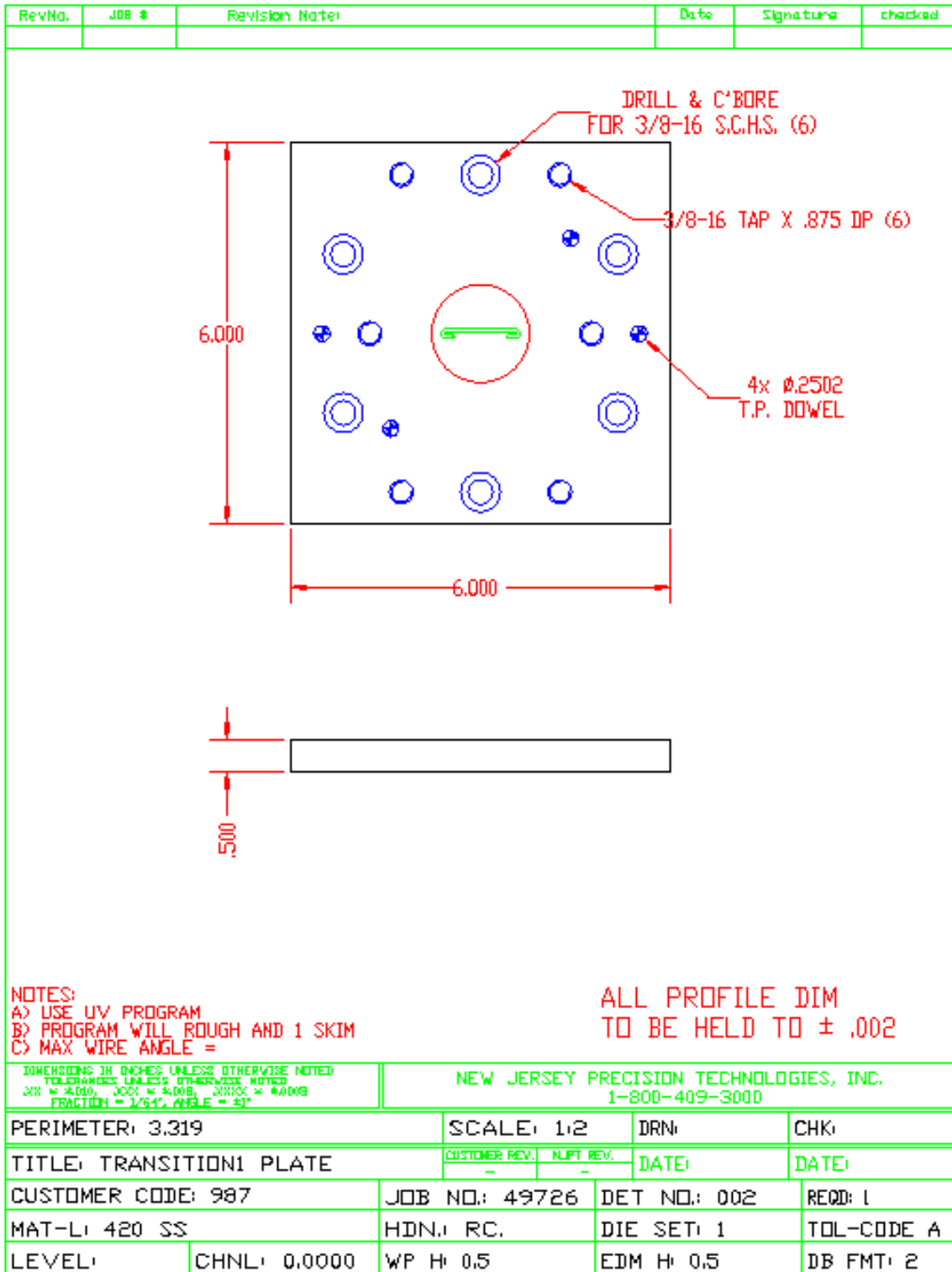
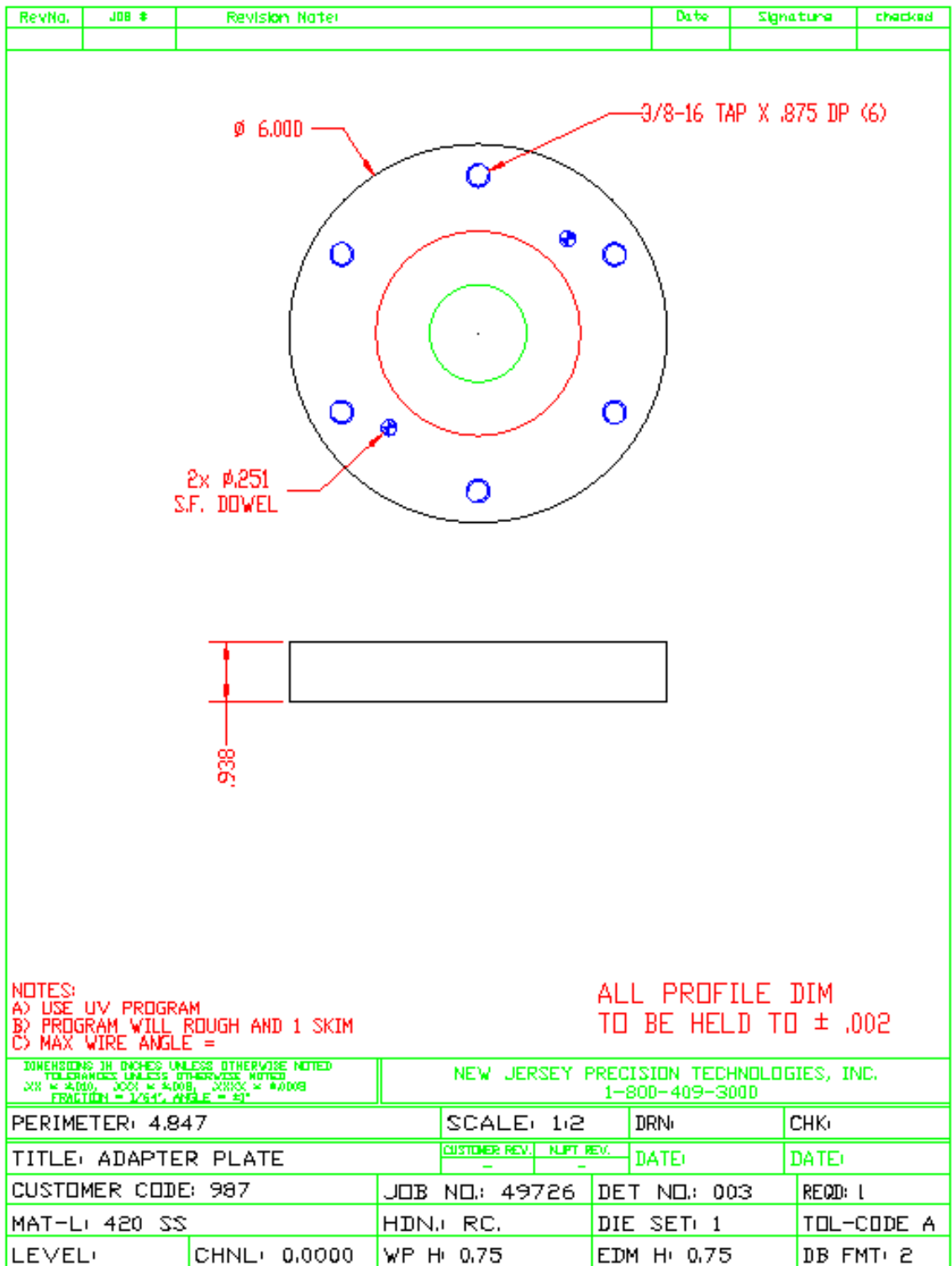


Figure C.17 Drawing sheet generated for Job 49726 depicting Die plate.



**Figure C.18** Drawing sheet generated for Job 49726 depicting Transition 1 plate.



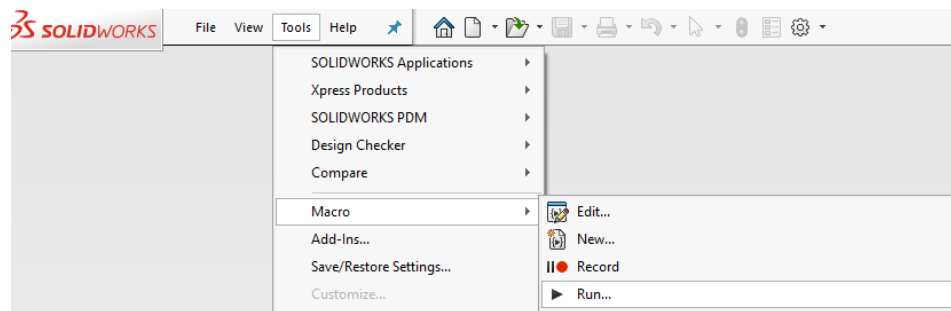
**Figure C.19** Drawing sheet generated for Job 49726 depicting Adapter plate.

## APPENDIX D

### EXPERT SYSTEM TRAINING DOCUMENT

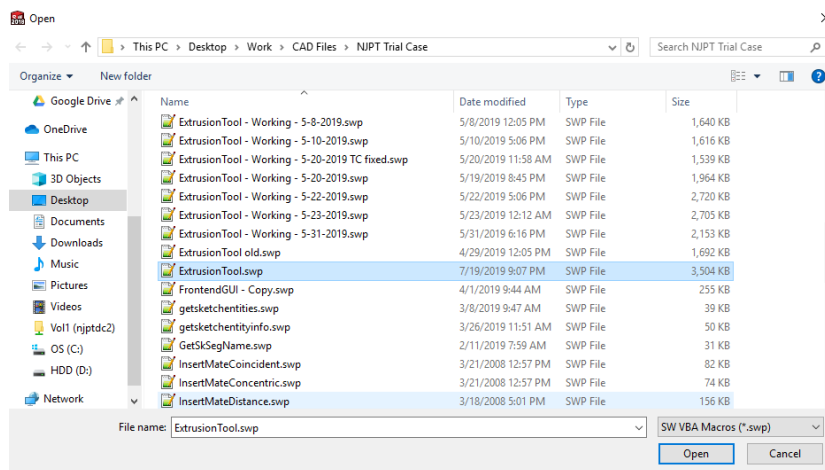
Figures D.1 to D.17 are the steps the designer has to follow to allow them to make use of the expert system.

1. In SolidWorks, Select Tools > Macro > Run



**Figure D.1** Locating the Run command for executing macros in SolidWorks.

2. Browse and select ExtrusionTool.swp from the working folder



**Figure D.2** File browser where the designer can select the customer profile.

3. The program will begin and the main page will be displayed. In this page, input the job number and customer code. Select the material of the blank and input a drawing scale. Enter your initials at the location provided and click Begin.

Output Control

Job No : 56877 Customer Code : 2145

Blank Material : 420 SS Drawing Scale : 1:2

Designer Initial: ALN

Begin

**Figure D.3** Output control frame in the GUI.

4. Next select Browse and choose the product profile that has to be designed and then click on Verify.

NJPT Extrusion Tooling Design Form v1.0

**New Jersey Precision Technologies, Inc.**  
*Improving lives through manufacturing innovation.*

Intro Profile Die Plate Transition Plate Adapter Plate

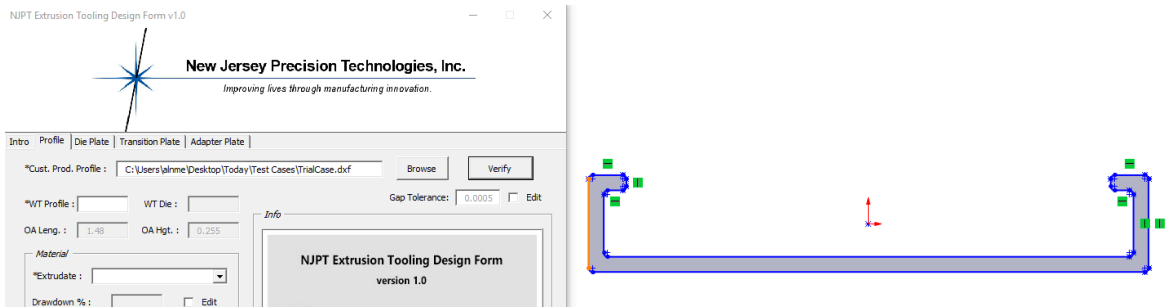
\*Cust. Prod. Profile : C:\Users\alme\Desktop\Today\Test Cases\TrialCase.dxf Browse Verify

\*WT Profile : WT Die : Gap Tolerance: 0.0005 Edit

**Figure D.4** Location in the GUI where the designer can import customer profile.

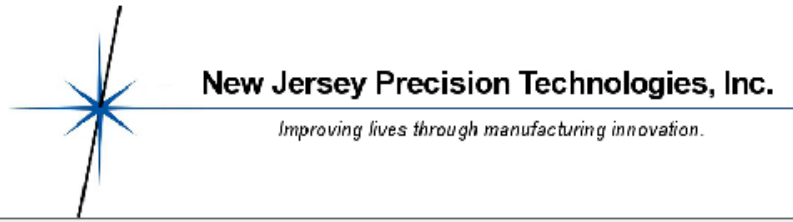


5. The product profile gets imported into SolidWorks and its overall dimensions will be updated in the GUI.



**Figure D.5** Customer profile gets imported into SolidWorks as a 2-D sketch.

6. Measure and enter the wall thickness of the profile (You can use the smart dimension tool). Assign the material for the extrudate and enable the necessary modules for leg modification, lead-in and flow restrictor as per design specifications. Default calculated values based on standard working protocol will be updated and can be edited if required in the design. You can also hover over any field in the GUI and the info box will show helpful hints regarding each field. Select Next when done entering information.



Intro | **Profile** | Die Plate | Transition Plate | Adapter Plate

\*Cust. Prod. Profile :

\*WT Profile :  WT Die :  Gap Tolerance:   Edit

OA Leng. :  OA Hgt. :

*Material*

\*Extrudate :

Drawdown % :   Edit

Wall Thick. % :   Edit

*Leg Modification*

Enable :  Leg Extension  Leg Flares

Outward Ext. (e1):   Edit

Inward Ext. (e2):   Edit

Flare Offset (e3):   Edit

*Lead - In*

Enable :  Chamfer Angle :

Type :   Ball Dia. :

*Flow restrictors*

Enable :  FR Diameter :   Edit

**Info**

**NJPT Extrusion Tooling Design Form**  
version 1.0

**SCOPE**

- Single extrusion
- Open channel profiles
- Maximum two transition plates
- Longest dimension of profile < 8 inches

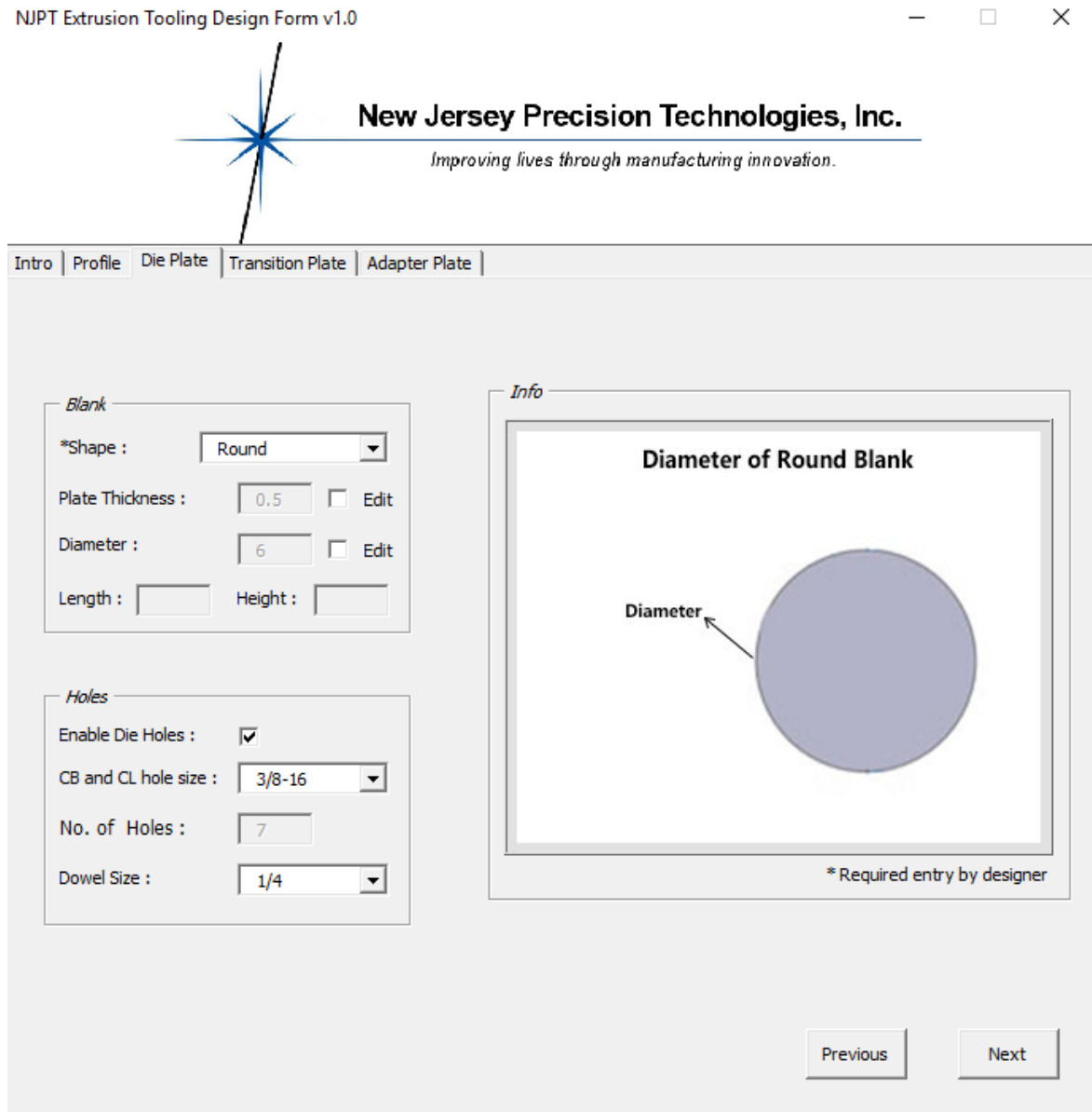
**INPUT** : Product profile .DXF format  
**OUTPUT** : Drawing of Die, Trans & Adapter in .DXF format

Hover mouse over labels more more information

\* Required entry by designer

**Figure D.6** The profile modification page of the extrusion tooling design GUI.

7. On the next page, select the shape of the blank for the die plate and verify the values that will be generated for the blank dimensions, screw holes and dowel holes. After entering information, select Next.



**Figure D.7** The die plate parameter page of the extrusion tooling design GUI.

8. The next page will have used the information entered so far to calculate all the parameters required to design the transition plate however, verify all the values and edit them if necessary. There is also an option to disable creation of transition plate drawing if it is not required by the designer. There is also an option to import a custom hole pattern as long as the import criteria is followed.

The screenshot shows a software window titled "NJPT Extrusion Tooling Design Form v1.0" with a logo for "New Jersey Precision Technologies, Inc." and the tagline "Improving lives through manufacturing innovation." The window has a tabbed interface with "Transition Plate" selected. The main area contains several sections:

- Options:** "Create Transition Plate drawing" is checked, and "Is there an existing transition plate with screw pattern?" is unchecked.
- Transition screw pattern (DXF):** A text input field is empty, with a "Browse" button to its right.
- Blank:** A section with three input fields: "Wire Cut Angle (deg)" set to 25, "Trans. Zone Thick." set to 1.25, and "No. of Plates" set to 1. Each has an "Edit" checkbox.
- Holes:** A section with five input fields: "Enable Trans Holes" is checked, "CB and CL Hole Size" is 3/8-16, "DR & TP Hole Size" is 3/8-16, "No. of CB & CL Holes" is 7, "No. of DR & TP Holes" is 7, and "Dowel Size" is 1/4.
- Info:** A box titled "Screw Pattern Import Criteria" containing a diagram of a hole pattern and a list of requirements:
  - Screw pattern should be in .DXF file format.
  - Blank geometry should not be present.
  - Origin of the drawing should be at the center of drawing.
  - Hole pattern has to be equally spaced.
    - o Circular pattern for round blanks.
    - o Rectangular for rectangular blanks.

At the bottom right, there are "Previous" and "Next" buttons.

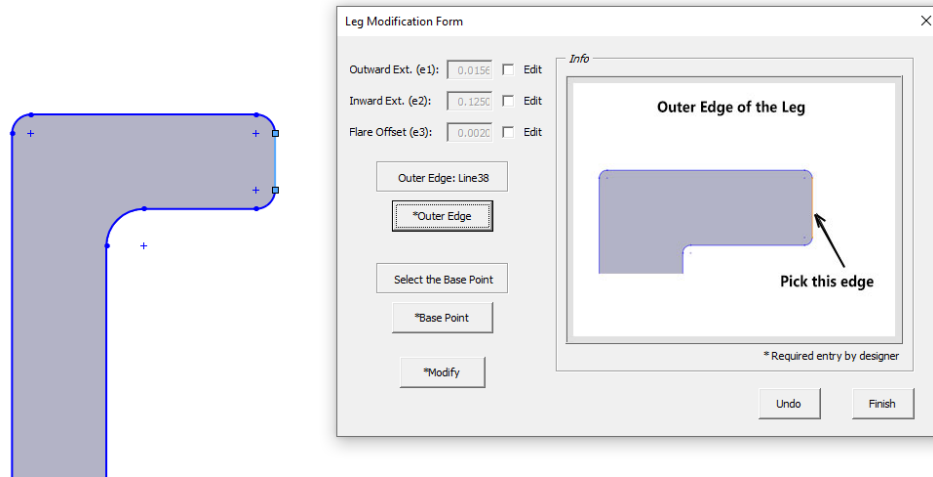
**Figure D.8** The transition plate parameter page of the extrusion tooling design GUI.

9. Finally, in the last page, enter the value for the plate thickness for the adapter plate which is usually provided by the customer. Verify all the calculated values and selections. Similar to the transition plate, the program also allows disabling adapter plate and importing custom screw pattern for the adapter plate. When all the information has been entered click on the Start button to begin the design.

The screenshot shows the 'Adapter Plate' tab of the 'NJPT Extrusion Tooling Design Form v1.0'. The window title bar includes standard minimize, maximize, and close buttons. The header features the NJPT logo and the company name 'New Jersey Precision Technologies, Inc.' with the tagline 'Improving lives through manufacturing innovation.' Below the header is a navigation bar with tabs for 'Intro', 'Profile', 'Die Plate', 'Transition Plate', and 'Adapter Plate'. The main form area contains several sections: 'Create Adapter Plate drawing' (checked), 'Is there an existing adapter plate with screw pattern?' (unchecked), and an 'Adapter screw pattern (DXF)' field with a 'Browse' button. The 'Blank' section includes '\*Plate Thickness' (input field), 'Blank Dia.' (input field with '6' and an 'Edit' checkbox). The 'Profile' section includes 'Extruder Outlet Dia.' (dropdown with '2.5'), 'Outlet Prof. Shape' (dropdown with 'Round'), and 'Diameter' (input field with 'TBD'). The 'Holes' section includes 'Enable Adap Holes' (checked), 'DRL & Tap Hole Size' (dropdown with '3/8-16'), 'No. of Holes' (input field with '7' and an 'Edit' checkbox), and 'Dowel Size' (dropdown with '1/4'). On the right, an 'Info' box displays a large 'ADAPTER PLATE' label and a note '\* Required entry by designer'. At the bottom right are 'Previous' and 'Start' buttons.

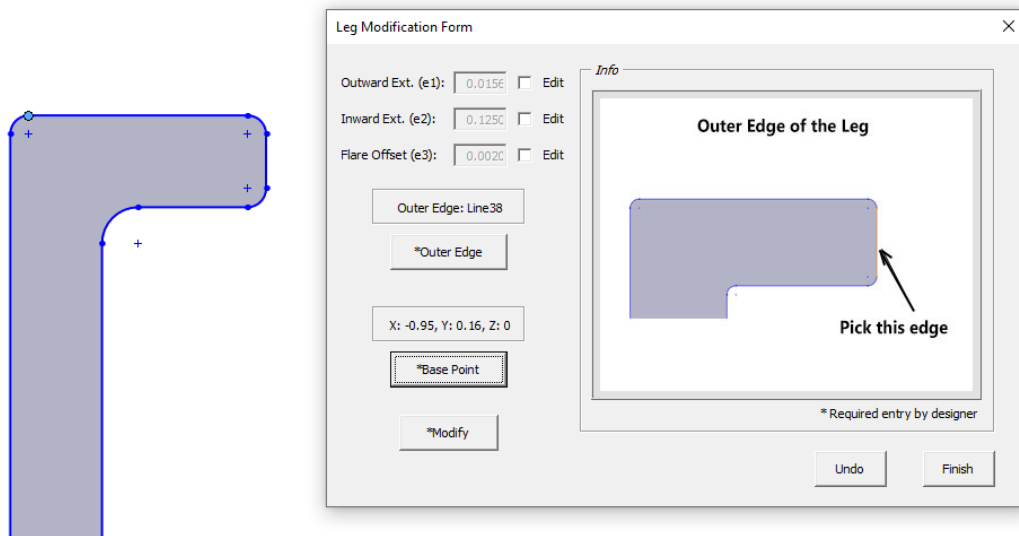
**Figure D.9** The adapter plate parameter page of the extrusion tooling design GUI.

10. If the leg modification module has been enabled, during the design process the leg modification GUI will show up. Zoom into the legs of the profile and follow the steps suggested in the GUI. The first step is to select the outer edge of the leg that requires modification and click on Outer Edge to add it into memory.



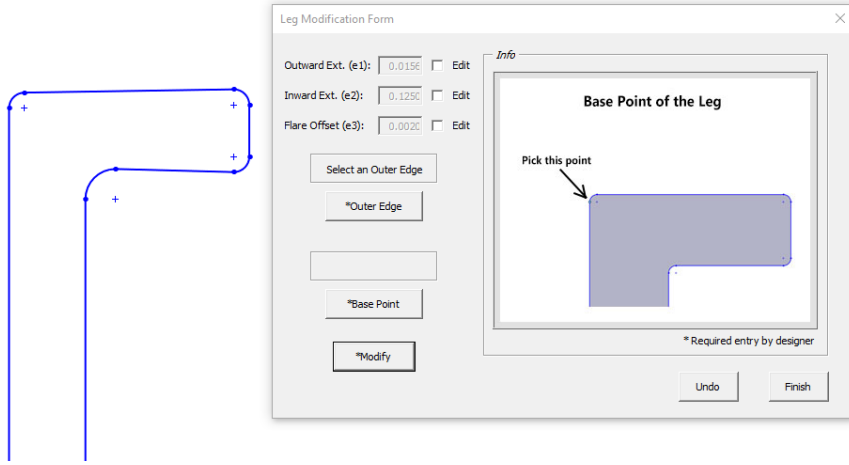
**Figure D.10** Selecting the Outer Edge on the leg modification GUI.

11. Next select the base point of the leg as shown and click on Base Point.



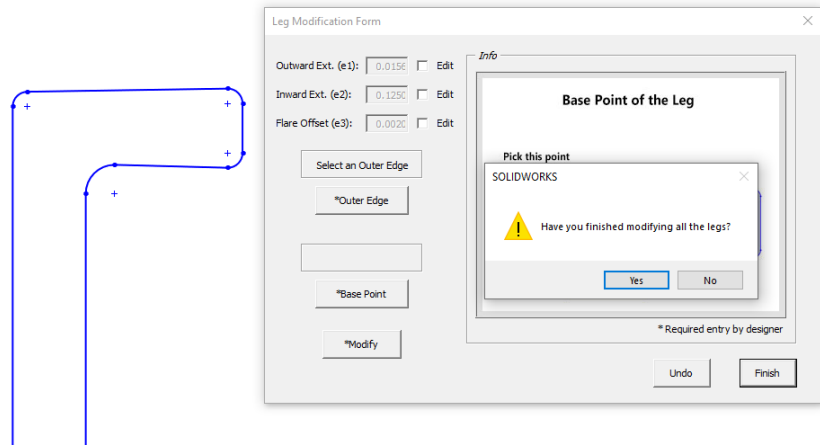
**Figure D.11** Selecting the Outer Edge on the leg modification GUI.

12. Once the Outer Edge and Base Point has been selected, click on Modify. The program will determine the type of the leg and perform the necessary modifications.



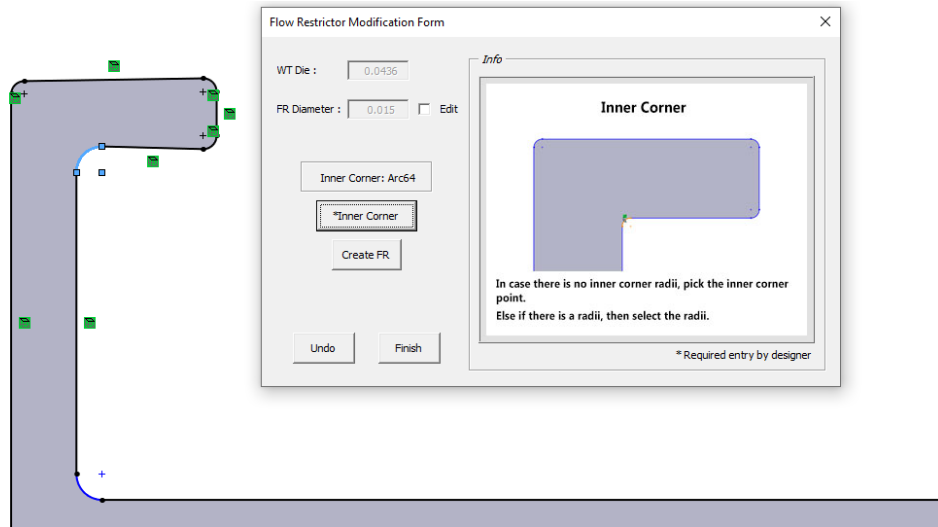
**Figure D.12** Modification of legs done based on selections in the GUI.

13. This process can be repeated to modify all the legs. In case the wrong segment was selected and the design was not done correctly, click on the Undo button to retrace your steps. When all the legs are modified click on the Finish button to continue the program.



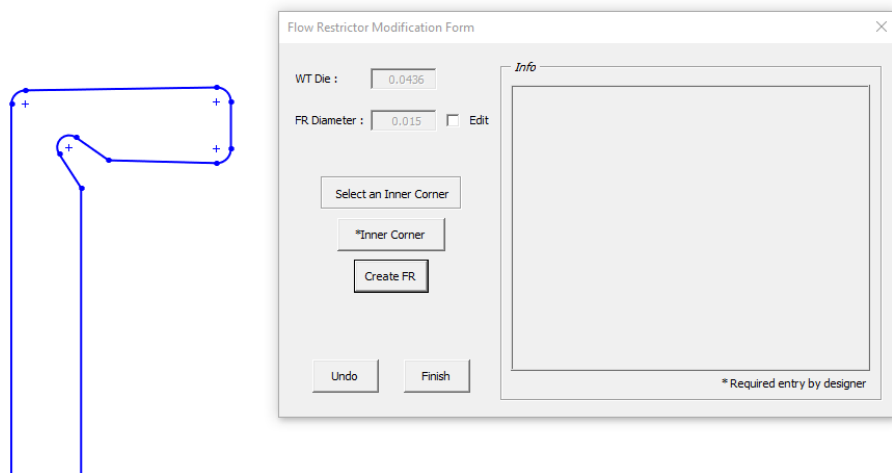
**Figure D.13** Confirming that all legs have been modified within the GUI.

14. If the flow restrictor module was enabled, during the design the flow restrictor modification GUI will show up. Here, select the inner corner where a flow restrictor has to be added and click on the Inner Corner button.



**Figure D.14** GUI used to locate the position to insert a flow restrictor feature.

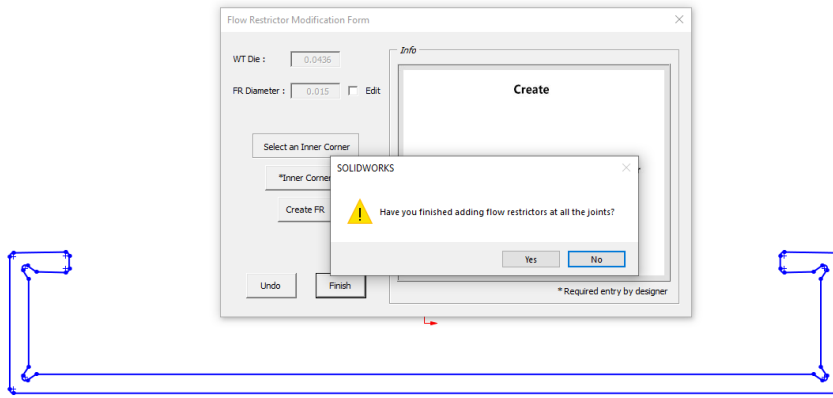
15. Once the Inner Corner has been selected into memory, click on the Create FR button for the program to automatically create a flow restrictor at that location.



**Figure D.15** Flow restrictor has been added at the selected inner corner.

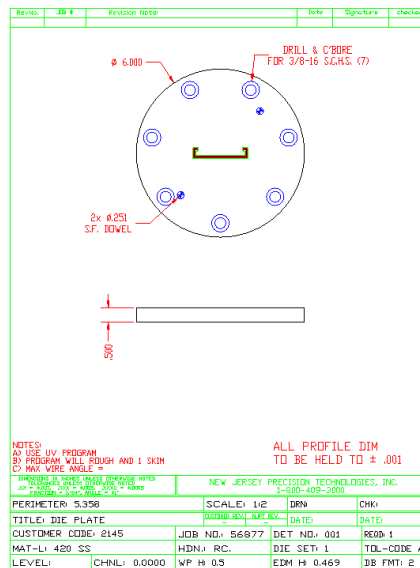


16. This process can be repeated till flow restrictors are added on all the joints. There is also an Undo button if required. When all the flow restrictors have been added, click on the Finish button to continue the program.



**Figure D.16** Confirming all flow restrictors at the selected location have been added.

17. Now the rest of the design will be done automatically by the program and the final output drawing sheets will be created for each plate. These sheets will be saved in the same directory, that the customer profile was imported from.



**Figure D.17** Drawing sheet gets generated at the end with all the profiles in its assigned layers.