

Copyright Warning & Restrictions

The copyright law of the United States (Title 17, United States Code) governs the making of photocopies or other reproductions of copyrighted material.

Under certain conditions specified in the law, libraries and archives are authorized to furnish a photocopy or other reproduction. One of these specified conditions is that the photocopy or reproduction is not to be “used for any purpose other than private study, scholarship, or research.” If a user makes a request for, or later uses, a photocopy or reproduction for purposes in excess of “fair use” that user may be liable for copyright infringement,

This institution reserves the right to refuse to accept a copying order if, in its judgment, fulfillment of the order would involve violation of copyright law.

Please Note: The author retains the copyright while the New Jersey Institute of Technology reserves the right to distribute this thesis or dissertation

Printing note: If you do not wish to print this page, then select “Pages from: first page # to: last page #” on the print dialog screen

The Van Houten library has removed some of the personal information and all signatures from the approval page and biographical sketches of theses and dissertations in order to protect the identity of NJIT graduates and faculty.

ABSTRACT

FIELD ORIENTED CONTROL OF PERMANENT MAGNET SYNCHRONOUS MOTOR WITH THIRD-HARMONIC INJECTION PULSE WIDTH MODULATION TO REDUCE QUADROTORS' SPEED RIPPLES

by

Yuxi Shi

The world's commercial unmanned aerial vehicle (UAV) industry has witnessed unprecedented boom in recent years. Delighted with an ample supply of this excellent high-tech product, global consumers are paying more attention on UAVs. Civilian UAVs now vastly outnumber military ones, with the estimate of over a million sold by 2016. An UAV has various degrees of autonomy as enabled by the use and precise control of motors. Traditional Direct Current (DC) motors are replaced by permanent magnet synchronous motors (PMSM) associated with the new power electronic inverters. Because of a PMSM's higher power density than a DC motor, it reduces the rotor losses, thus improving its efficiency. The other improvement comes from the advanced control methods. The simple drive system based on a DC motor with open-loop control is outdated. High frequency switches in power electronic inverters offer an opportunity to change motor input voltage values and frequencies faster than ever before. Vector control approaches are employed with closed-loop feedback control, which brings high precision and good dynamics. Integrated inverter-motor drive systems are in progress. This thesis focuses on how to control PMSM installed in the

UVAs with a high performance of dynamic response and fewer speed ripples. Field Oriented Control (FOC) is one type of vector controls to control a PMSM in a quadrotor. FOC of PMSM and Pulse Width Modulation (PWM) are introduced. The simulation results of FOC of PMSM with third-harmonic injection PWM and traditional FOC are compared. This comparison proves that FOC of PMSM with third-harmonic injection provides a better dynamic response for a quadrotor's movement in vertical direction. In addition, since PWM is helpful to reduce the speed ripples, PMSM has a better steady-state response during operations.

**FIELD ORIENTED CONTROL OF PERMANENT MAGNET
SYNCHRONOUS MOTOR WITH THIRD-HARMONIC INJECTION PULSE
WIDTH MODULATION TO REDUCE QUADROTORS' SPEED RIPPLES**

**by
Yuxi Shi**

**A Thesis
Submitted to the Faculty of
New Jersey Institute of Technology
in Partial Fulfillment of the Requirements for the Degree of
Master of Philosophy in Electrical Engineering**

**Helen and John C. Hartmann Department of
Electrical and Computer Engineering**

May 2017

APPROVAL PAGE

**FIELD ORIENTED CONTROL OF PERMANENT MAGNET
SYNCHRONOUS MOTOR WITH THIRD-HARMONIC INJECTION PULSE
WIDTH MODULATION TO REDUCE QUADROTORS' SPEED RIPPLES**

Yuxi Shi

Dr. Mengchu Zhou, Thesis Advisor Date
Distinguished Professor of Electrical and Computer Engineering, NJIT

Dr. Yunqing Shi, Committee Member Date
Professor of Electrical and Computer Engineering, NJIT

Dr. Xiwang Guo, Committee Member Date
Lecturer of Electrical and Computer Engineering, Liaoning Shihua University, the
People's Republic of China

BIOGRAPHICAL SKETCH

Author: Yuxi Shi

Degree: Master of Science

Date: May 2017

Undergraduate and Graduate Education:

- Master of Science in Electrical Engineering,
New Jersey Institute of Technology, Newark, NJ, 2017
- Bachelor of Science in Electrical Engineering,
Guangdong University of Technology, Guangzhou, P. R. China, 2013

Major: Electrical Engineering

To my family I dedicate this thesis in token of affection and gratitude

ACKNOWLEDGMENT

I would like to show my deepest appreciation to my thesis advisor, Dr. Mengchu Zhou, a responsible and respectable professor. He was always patient and kind to answer my questions. His careful revision of my thesis left me a deep impression.

I would like to take this opportunity to thank my committee members Dr. Yunqing Shi and Dr. Xiwang Guo. They give me a lot of constructive suggestions for my thesis.

Also, I am grateful to Dr. Sisi Li and Dr. Haobo Lai, for their helpful encouragement and insightful comments.

TABLE OF CONTENTS

Chapter	Page
1 INTRODUCTION	1
1.1 Background	1
1.2 Objective	3
1.3 Organization of This Thesis	5
2 LITERATURE REVIEW	7
2.1 Introduction to High Performance Control of AC Electric Motors	7
2.2 AC Motors	8
2.3 Control Systems of AC Motors	10
2.4 Pulse Width Modulation of Power Electronic	13
3 MODELING OF PERMANENT MAGNET SYNCHRONOUS MOTOR	16
3.1 Space Vector Representation	16
3.1.1 Clark Transformation	16
3.1.2 Park Transformation	18
3.2 Model of Permanent Magnet Synchronous Motor	19
4 THIRD-HARMONIC INJECTION PULSE WIDTH MODULATIO OF POWER ELECTRONIC INVERTER	23
4.1 Pulse Width Modulation	23
4.2 Third-harmonic Injection Pulse Width Modulation	28
5 FIELD ORIENTED CONTROL OF PERMANENT MAGNET SYNCHRONOUS MACHINE	30
5.1 The Principle of Field Oriented Control	30
5.2 Basic Field Oriented Control of PMSM Scheme	31
6 REALIZATION OF FIELD ORIENTED CONTROL OF PERMANENT MAGNET SYNCHRONOUS MACHINE WITH THIRD-HARMONIC INJECTION PULSE WIDTH MODULATION	34
6.1 Simulation of FOC of PMSM with Third-harmonic Injection	34
6.2 Comparison of Simulation of FOC of PMSM with Third-harmonic Injection and Traditional FOC of PMSM	41
7 CONCLUSION	49
7.1 Contributions of This Thesis	49
7.2 Limitations and Future Work	50
REFERENCES	51

LIST OF TABLES

Table	Page
4.1 Leg voltages of three-phase SPWM	25
4.2 Phase-to-neutral voltages of three-phase SPWM	26
4.3 Line voltages of three-phase SPWM	27
6.1 PMSM parameters	37

LIST OF FIGURES

Figure	Page
1.1 Google searches for “Unmanned aerial vehicle”	2
2.1 Electric drive system for tailless quadcopters.....	8
2.2 Categories of AC motors.....	9
2.3 Control schemes of motors	11
3.1 Stator current Vector in an α - β stationary frame.....	16
3.2 i_s in a three-phase frame and an α - β stationary frame.....	17
3.3 Stator current Vector in a d - q rotating frame.....	18
3.4 Scheme of the PMSM in a d - q frame.....	21
4.1 DC/AC three-phase inverter model	24
4.2 Modulating signal and carrier signal.....	24
4.3 V_{AO} curve	26
4.4 V_{An} curve.....	27
4.5 V_{AB} curve	28
4.6 Sinusoidal modulating signals with injection of third-harmonic	29
5.1 Field oriented control of PMSM scheme	31
5.2 Field oriented control without PWM scheme	32
6.1 Scheme of FOC of PMSM with third-harmonic injection PWM.....	35
6.2 Third-harmonic injection PWM injection.....	36
6.3 500 rpm speed response	38
6.4 500 rpm torque response	39
6.5 I_d and I_q in a d - q rotating frame.....	39
6.6 Three-phase currents curves	40
6.7 Speed changes from 500 rpm to 1000 rpm	40
6.8 Quadrotor’s rising vertical motion scheme.....	41
6.9 1500rpm with FOC of PMSM with three-harmonic injection.....	42
6.10 1500rpm with traditional FOC of PMSM.....	42
6.11 Comparison two control methods at 1500rpm.....	43
6.12 From 500rpm to 1500rpm with FOC of PMSM with three-harmonic injection.....	44
6.13 From 500rpm to 1500rpm with traditional FOC of PMSM.....	44
6.14 Comparison between two control methods at from 500rpm to 1500rpm.....	45
6.15 Random speed with FOC of PMSM with three-harmonic injection.....	46
6.16 Random speed with traditional FOC of PMSM.....	46
6.17 Comparison between two control methods at random motor speed.....	47
6.18 Motor speed reduction by the two control methods.....	48

CHAPTER 1

INTRODUCTION

1.1 Background

An unmanned aerial vehicle (UVA) is an aircraft without a human pilot aboard, which originated in military applications. The world's commercial UAV industry has witnessed unprecedented boom in recent years. UAV companies have expanded their clients beyond the military applications and pay more and more attention to scientific and commercial market. Civilian UAVs now vastly outnumber military ones and were estimated to reach over a million sales by 2016.

An unmanned aircraft system (UAS) includes an UAV, a ground-based controller, and a communication system between the two. An UAV has various degrees of autonomy. It can be remotely controlled by a human operator and also onboard computers fully autonomously. The applications of UVAs fall into the following categories.

1. Target: UAVs can simulate as a ground and aerial enemy aircraft or missile.
2. Reconnaissance: UAVs provide battlefield intelligence in real time.
3. Combat: UAVs have attack capability to assist people for high-risk missions.
4. Logistics: UAVs can deliver cargo, which leaves a profound impression on the public.

- Civil and commercial applications: Traditional industries gradually make use of UAVs.

Among these applications, the general public are usually familiar with the civil and commercial applications. It is dramatic that UAVs are resolving some risky problems and providing additional auxiliary work in traditional industry. To some extent, this kind of UAVs resemble a partner during work thanks to its good interactions with people. The increasing volume of searching for ‘Unmanned aerial vehicle’ in Google reflects the prosperity of civil and commercial UAVs in the world, as shown in Figure 1.1.

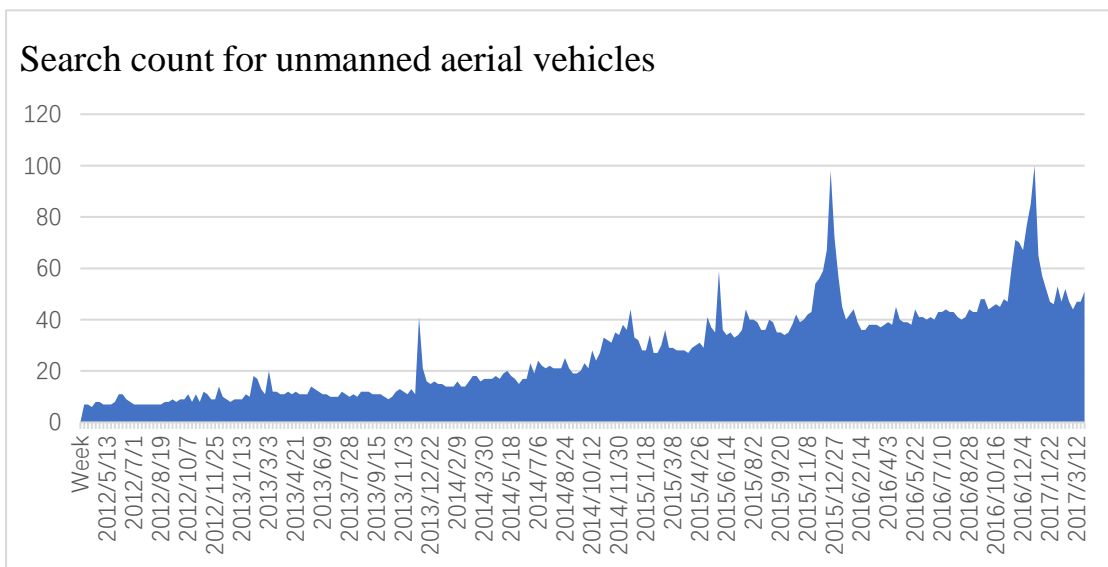

Figure 1.1 Google searches for “Unmanned aerial vehicle”.

Numbers in vertical axis represent search interest relative to the highest point on the chart for the given region and time. A value of 100 is the peak popularity for the term. A value of 50 means that the term is half as popular. Likewise, a score of 0 means the term is less than 1% as popular as the peak. The first peak took place on

December 27, 2015. In that week the Amazon company announced that a small UAV was tested to deliver cargo in thirty minutes. Another peak took place on December 24, 2016. This was because a Chinese UAV company called DJI released a new product named 'Mavic', a kind of breakthrough folding quadcopters.

1.2 Objective

It is getting harder to go anywhere without seeing propaganda from the flat media and Internet. The leading civil and commercial UAV company is currently Chinese DJI with over \$500 million dollar global sales in 2016. About 325,000 civilian UAVs were registered with the U.S. FAA, though it is estimated more than a million UAVs have been sold in the United State alone.

In recent years, more and more people benefit from the applications of UAVs because they help raise the productivity. The common civil uses include aerial photography, inspection of power line and pipelines, cooperative environment monitoring, and forest fire detection and monitoring.

Needless to say, most users could control UAVs with ease. UAV manufacturers often build in specific autonomous operations, such as:

1. Self-level: stabilizing its altitude.
2. Hover: attitude stabilization on the pitch, roll and yaw axes.
3. Care-free: The UAV automatic roll and yaw control while moving horizontally.
4. Take-off and landing

5. Failsafe: The UAV automatically landing upon loss of control signal
6. Return-to-home
7. GPS waypoint navigation
8. Orbit around an object
9. Pre-programmed tricks such as rolls and loops

For small UAVs, the design has become popular, though this layout is rarely used for a manned aircraft. It is easy to recognize the following components of a UAV, such as:

1. Body: There are two kinds of UVAs. One is tailless quadcopters and the other one is fixed-wing UVA. Tailless quadcopters are common.
2. Power supply: Small UVAs mostly use lithium-polymer batteries. Larger UAVs usually use aviation gasoline.
3. Sensor: Position and movement sensors give information about the aircraft state. Non-cooperative sensors are able to detect targets autonomously and used for separation assurance and collision avoidance.
4. Motor: Brushless DC motors were previously installed in most UAVs. Nowadays permanent magnet synchronous motors are replacing brushless DC motors gradually in some advanced UAVs.

In spite of UAVs' violent reputation, many areas could benefit from them. Their

electrical power capacity really sets them apart. It roughly has passed through three stages of development of quadcopter motors. The first stage was direct current (DC) motors with a simple structure. Then brushless DC motors were introduced into quadcopters. Since this kind of motors has lower amounts of magnets, it is difficult to have a very good dynamic performance and high control precision. High dynamic requirements are satisfied by using Permanent Magnet Synchronous Motors (PMSMs) because they have higher amounts of magnets. So PMSMs are gradually replacing brushless DC motors in quadcopters. In this thesis, by systematically considering the control system of PMSM in quadcopters and how to obtain a fast dynamic while minimizing speed ripple, Field Oriented Control (FOC) with third-harmonic injection-based Pulse Width Modulation (PWM) is designed to identify an opportunity to improve operational performance of UAVs. Simulation results are given and compared to FOC with PWM but not including third-harmonic injection. The simulation provides a better understanding of controlling a quadcopter in different operations.

1.3 Organization of This Thesis

The rest of this thesis is organized as follows. Chapter 2 presents the related works including AC motors and their typical control methods, field oriented control of permanent magnet synchronous motor and pulse width modulation. Chapter 3 introduces how to build a model of a permanent magnet synchronous motor in a $d-q$ frame by using Clark transformation and Park transformation. Chapter 4 gives the

concept of pulse width modulation and third-harmonic injection. The simulation results are also given. Chapter 5 discusses the details of field oriented control of a permanent magnet synchronous motor. The basic control scheme is illustrated by using MATLAB/Simulink. Chapter 6 discusses experimental results and makes comparison between the proposed method and the traditional field oriented control of permanent magnet synchronous motor. The simulation results are specified in this section. Chapter 7 concludes the whole thesis and indicates the future work.

CHAPTER 2

LITERATURE REVIEW

2.1 Introduction to High Performance Control of AC Electric Motors

An AC motor is one of the essential components of a tailless quadcopter. Every autonomous operation depends on the high performance of AC motor installed in a tailless quadcopter. Thus, there exists a huge demand for the improvement of its performance.

One approach could be the special design of motors with high-energy efficiency especially for aviation gasoline motors. Other approach is to do the proper control of machines. Tailless quadcopters employed in various application run at different speed. Controlling the operation of an electrical machine by varying its speed, in literature, is called ‘variable speed drives’ or ‘adjustable speed drives’. These control techniques are in general called ‘high-performance drives’ because they offer extremely fast and precise dynamic and steady-state response of electric machines.

Design and operations of electric drives for tailless quadcopters require the knowledge of electric motors, actuators, power electronic converters, sensors and instrumentation, control hardware and software, and communication links. In this thesis, we primarily pay attention to AC motors, control system and power electronic in a tailless quadcopter to drive its propellers. These three parts will be discussed one by one.

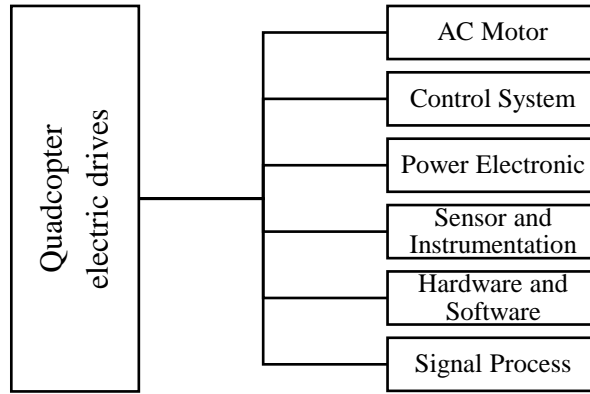

Figure 2.1 Electric drive system for tailless quadcopters.

2.2 AC Motors

Thanks to the contribution to the success of AC motors in motion control and to the continuing growth of their application, AC motors with high performance are used in UAVs especially for tailless quadcopters. Choosing the suitable control methods associated with AC motors for tailless quadcopters to satisfy different requirements is a significant issue.

‘AC motors’ refers to electric machines that convert AC electric energy into mechanical energy. Considering their huge difference of operational principles, physical characteristics and power level, there is a wide variety of such machines. According to their operation principles, AC motors are usually classified two main categories: induction and synchronous ones. Each kind of motor also contain two categories, as shown in Figure 2.2.

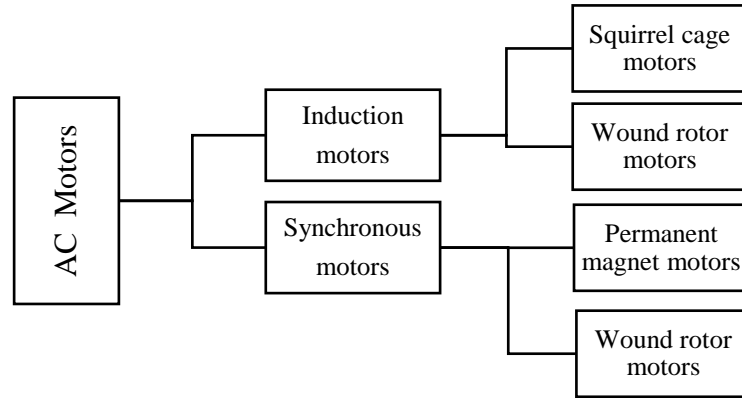

Figure 2.2 Categories of AC motors.

Induction motors include two types, squirrel cage and wound rotor ones. Synchronous motors also contain two kinds of motors, permanent magnet and wound rotor ones. There have been continued developments in the field of electric drives since the inception of the first principle of electrical motors by Michael Faraday in 1821 [1]. The world dramatically changed after the first induction machines was patented (US Patent 381968) by Nikola Tesla in 1888 [2]. Induction motors have gained widespread use in industry because of their affordable price and reliable performance. However, permanent magnet synchronous motors are one technological wave squeezing induction motors. They are more suitable for tailless quadcopter than induction motors.

Over the last decades, people payed ever-increasing attention to permanent magnet synchronous motors (PMSMs). The idea of substituting the electrical excitation winding of a synchronous machine with the magnets dates back to the nineteenth century, but only with discovery of rare-earth magnets the PMSM begins to be gradually applied to industry.

Nowadays, PMSMs are widely used for the following reasons:

1. No rotor windings are present, and electrical contacts are on the stators side only.
2. The absence of excitation windings reduces electrical losses and PMSMs need less cooling.
3. PMSMs have a higher torque density and power density than induction motors.
4. A higher air-gap flux density brings PMSMs to a better dynamic performance relative to induction motors.

The most important application of PMSMs is servo systems. This field requires high instantaneous torque, lower torque and speed ripple and a wide adjustable speed range. The control of a PMSM servo system plays an important role in achieving the objective of high performance subjected to parameter variations and external load disturbances. Some discussion on the control methods to reduce the speed ripples for PMSMs in Tailless quadcopters is to be discussed later.

2.3 Control Systems of AC Motors

The control methods of AC motors are broadly classified into ‘scalar controls’ and ‘vector controls’. It is easy to implement scalar controls and obtain a relatively steady-state response. However, the dynamic response that scalar controls offer is slightly.

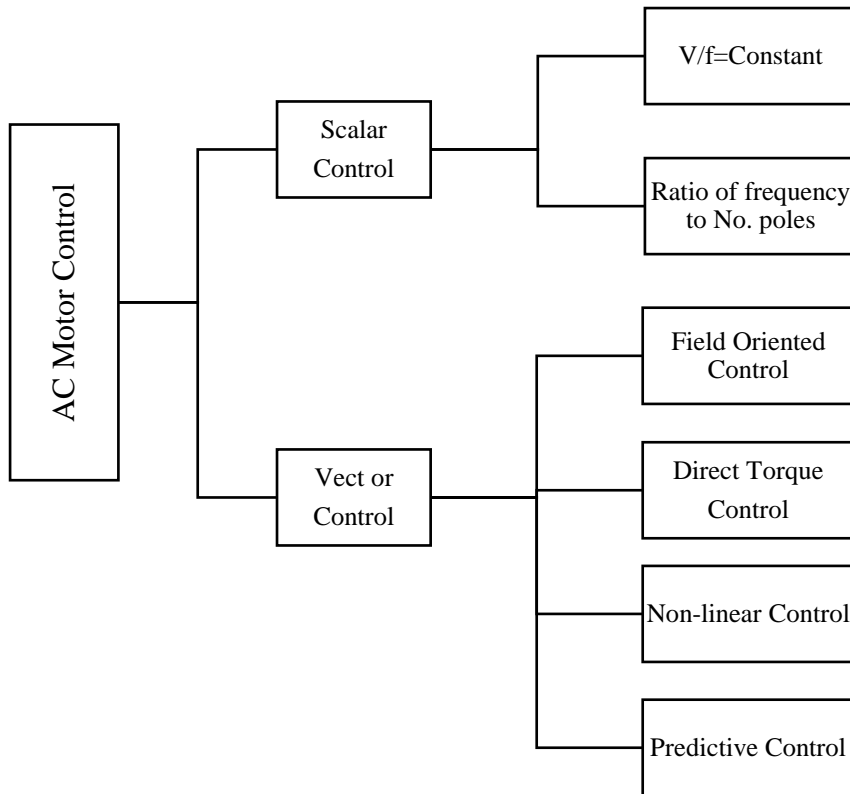

Figure 2.3 Control schemes of motors.

To improve precision and dynamics, as well as a steady-state response, vector controls are increasingly employed with a closed-loop feedback. There are four kinds of control methods based on vector controls, namely Field Oriented Control, Direct Torque Control, Non-linear Control and Predictive Control. This thesis focus on using Field Oriented Control of PMSM and power electronic inverter to obtain a fast dynamics response and lower speed ripple. The basic way to convert DC voltage to AC voltage associated with the vector controls by using the power electronic high frequency switches is called Pulse Width Modulation (PWM); hence, PWM will be discussed later.

DC motors are installed diffusely in industries for variable speed application,

because of their inherent decoupled torque and flux control with minimum electronics involved. However, dating back to the early 1970s, a breakthrough principle permitting torque and flux to be decoupled, more usually called ‘field oriented control’ or ‘vector control,’ allowed DC motors to a better dynamics and steady-state response. Induction machines firstly used this control method. Later, it was realized that such control method was also possibly used to control synchronous machines. However, until the early 1980s, when the microprocessor era began and the realization of complex control algorithms became accessible, the development of speed control for AC machines did grow rapidly [3,4].

Control of PMSM drives is relatively simpler than that of induction machines. Since torque and flux are decoupled, these two variables can be controlled separately. The rotor flux is produced by the permanent magnet and it is known once the rotor position is detected. In this way, the flux model of PMSM is not strictly required. In most cases, PMSMs can work with the maximum possible angle.

As known, a DC motor can provide a decoupled control of torque and flux. A PMSM could be controlled as a DC motor by field oriented control (FOC), with the similar dynamic performance. In PMSM, the control could be exploited only through the stator windings. The research on FOC is still passionate, with the combination of more advanced features for highly precise and accurate control, such as sensorless operation. The effect of parameter variations, magnetic saturation on the behavior of FOC are the subject of research in sensorless drives. The realization of artificial

intelligence is another concerned research in this field. It is prosperous for many manufactures to use FOC to control variable speed drives. FOC are welcome and growing rapidly in the market.

2.4 Pulse Width Modulation of Power Electronic

Power electronics is the application of solid-state electronics to the control and conversion of electric power. It plays a significant role in flexible operation in drive system. Improvement of power electronics converters is heavily relying on the development of semiconductor switches. Nowadays high frequency switches are available for manufacturing power electronics converters. The power electronics converters fall into four kinds, i.e., DC-DC (buck, buck-boost, boost converters), AC-DC (rectifiers), DC-AC (inverters), and AC-AC (cyclo-converters and matrix converters).

A few years ago, uncontrollable switches constituted inverter systems. With the development of semiconductor switches, more and more uncontrollable switches have been replaced by controllable switches. Also, diode-based semiconductors have been increasingly replaced by transistor-based semiconductors, such as insulated-gate bipolar transistor (IGBT), integrated gate-commutated thyristor (IGCT), metal–oxide–semiconductor field-effect transistor (MOSFET).

Employing an appropriate Pulse Width Modulation (PWM) technique, the output voltage or current can be improved. The main goal of this modulation technique

is to attain the maximum voltage and keep minimum Total Harmonic Distortion. There are two major types of PWM schemes. The most basic PWM is the Sinusoidal Pulse Width Modulation (SPWM). The high frequency carrier-wave is compared with the sinusoidal modulation wave to generate an appropriate gating signal for the inverters. The other type PWM, i.e., Space Vector Pulse Width Modulation (SVPWM), although appearing different to SPWM, has a strong implicit relationship with SPWM [9-13]. The gating time of each power switch is directly calculated from the analytical time equations in SVPWM.

The PWM technique is utilized in the inverter to output an AC voltage with variable frequency and amplitude. The input to the inverter is DC voltage, usually obtained from DC voltage or battery.

PWM and control of a power electronic inverter have attracted much attention for three decades. Research is still active in this area and several schemes have been suggested in the literature [5-6]. It is easier to apply the PWM than before because of modern signal processing devices, such as fast digital processors, microcontrollers, and Field Programmable Gate Arrays (FPGA).

The output voltage quality at the inverter side could be improved by using active or passive filters. Today, passive filtering is widely used at the output of the inverter. Such filters are hardware circuits installed in electric drive systems. The most common filters are based on resistors, inductors, and capacitors (LC filters).

The passive LC filters reduce the total harmonic distortion in both motor and line sides. However, in an electric drive system, instability may appear in case of electric resonance between L and C parameters. Then active damping techniques could be used to resolve the problem of instability and suppress the LC resonance at the same time.

Chapter 3

MODELING OF PERMANENT MAGNET SYNCHRONOUS MOTOR

3.1 Space Vector Representation

Building a mathematical model of a permanent magnet synchronous motor (PMSM) is the first step to the design and application of a control system. Three-phase motor control system can be significantly simplified when a space vector method is adopted. Thus, the concept of a space vector is introduced first before designing a controller for a PMSM. A three-phase AC motor can be represented by using the space vector model [7-15], as shown in [6]. The space vector represents AC motor variables, such as current, voltage and flux. Using the space vector principle to AC motors, the variables in three-phase ABC system are transformed to an α - β stationary frame (called Clark transformation), or d - q rotating frame (called Park transformation).

3.1.1 Clark Transformation

As shown in Figure 3.1, three-phase current is represented in the α - β stationary frame.

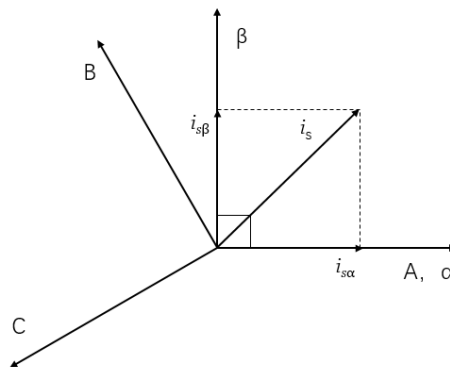

Figure 3.1 Stator current Vector in an α - β stationary frame.

Usually, AC motor stator three-phase currents are defined as i_{sA} , i_{sB} and i_{sC} . The stator current vector \bar{i}_s and $i_{s\alpha}$ and $i_{s\beta}$ are described in a complex form:

$$\bar{i}_s = i_{s\alpha} + ji_{s\beta} \quad (3.1)$$

where

$$i_{s\alpha} = \text{Re} \left\{ \frac{2}{3} [\bar{i}_{sA} + ai_{sB} + a^2i_{sC}] \right\} \quad (3.2)$$

$$i_{s\beta} = \text{Im} \left\{ \frac{2}{3} [\bar{i}_{sA} + ai_{sB} + a^2i_{sC}] \right\} \quad (3.3)$$

$$a = e^{j\frac{2}{3}\pi} \quad (3.4)$$

$$a^2 = e^{j\frac{4}{3}\pi} \quad (3.5)$$

$$i_{sA} + i_{sB} + i_{sC} = 0 \quad (3.6)$$

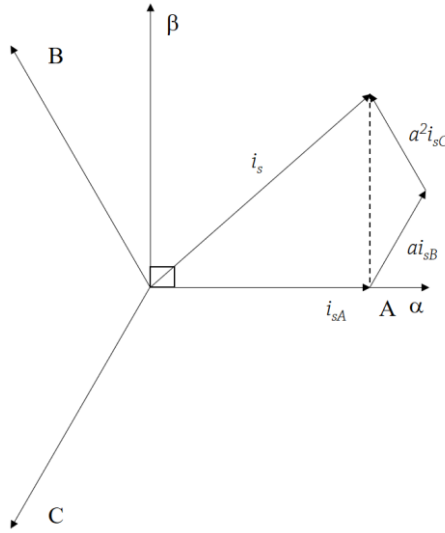

Figure 3.2 i_s in a three-phase frame and an α - β stationary frame.

As shown in Figure 3.2, i_s has two components separately in α and β axes. $i_{s\alpha}$ and $i_{s\beta}$

can be calculated from:

$$i_{s\alpha} = i_{sA} \quad (3.7)$$

$$i_{s\beta} = \frac{1}{\sqrt{3}} (i_{sA} + 2i_{sB}) \quad (3.8)$$

This is equivalent to

$$\begin{bmatrix} i_{s\alpha} \\ i_{s\beta} \end{bmatrix} = \begin{bmatrix} 1 & 0 & 0 \\ \frac{1}{\sqrt{3}} & \frac{2}{\sqrt{3}} & 0 \end{bmatrix} \begin{bmatrix} i_{sA} \\ i_{sB} \\ i_{sC} \end{bmatrix} \quad (3.9)$$

The above transformation is named as Clark transformation.

The inverse Clark transformation from an α - β stationary frame to a three-phase ABC system is

$$\begin{bmatrix} i_{sA} \\ i_{sB} \\ i_{sC} \end{bmatrix} = \begin{bmatrix} 1 & 0 \\ -\frac{1}{2} & -\frac{\sqrt{3}}{2} \\ -\frac{1}{2} & \frac{\sqrt{3}}{2} \end{bmatrix} \begin{bmatrix} i_{s\alpha} \\ i_{s\beta} \end{bmatrix} \quad (3.10)$$

3.1.2 Park Transformation

As shown in Figure 3.2, three-phase current is represented in the d - q rotating frame.

Park transformation aims to transform variables in an α - β stationary frame to a d - q rotating frame.

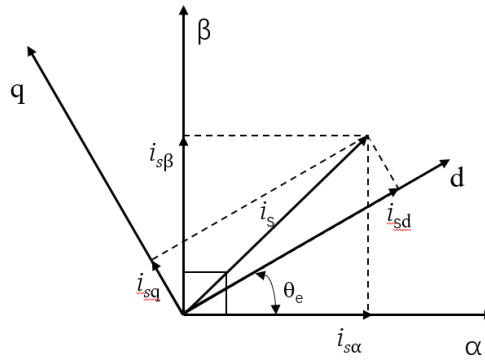

Figure 3.3 Stator current Vector in a d - q rotating frame.

The current vector in d - q frame is

$$\bar{i}_s = i_{sd} + j i_{sq} \quad (3.11)$$

which is equivalent to

$$\bar{i}_s = (i_{s\alpha}\cos\theta_e + i_{s\beta}\sin\theta_e) + j(i_{s\beta}\cos\theta_e - i_{s\alpha}\sin\theta_e) \quad (3.12)$$

This is equivalent to

$$\begin{bmatrix} i_{sd} \\ i_{sq} \end{bmatrix} = \begin{bmatrix} \cos\theta_e & \sin\theta_e \\ -\sin\theta_e & \cos\theta_e \end{bmatrix} \begin{bmatrix} i_{s\alpha} \\ i_{s\beta} \end{bmatrix} \quad (3.13)$$

The inverse Park transformation is

$$\begin{bmatrix} i_{s\alpha} \\ i_{s\beta} \end{bmatrix} = \begin{bmatrix} \cos\theta_e & -\sin\theta_e \\ \sin\theta_e & \cos\theta_e \end{bmatrix} \begin{bmatrix} i_{sd} \\ i_{sq} \end{bmatrix} \quad (3.14)$$

Combining Clark transformation with Park transformation gives the Park-Clark transformation from three-phase variables to a d - q rotating frame.

The stator current transformation from three-phase to d - q rotating frame is

$$\begin{bmatrix} i_{sd} \\ i_{sq} \end{bmatrix} = \begin{bmatrix} \cos\theta_e & \cos(\theta_e - \frac{2\pi}{3}) & \cos(\theta_e - \frac{4\pi}{3}) \\ -\sin\theta_e & -\sin(\theta_e - \frac{2\pi}{3}) & -\sin(\theta_e - \frac{4\pi}{3}) \end{bmatrix} \begin{bmatrix} i_{sA} \\ i_{sB} \\ i_{sC} \end{bmatrix} \quad (3.15)$$

It is much simplified that using Clark transformation and Park transformation to calculate stator current i_{sd} and i_{sq} instead of three-phase currents i_{sA} , i_{sB} and i_{sC} . In field oriented control system, i_{sd} is commonly kept in zero. So the only stator current need to be calculated is i_{sq} . The details are discussed in chapter 5.

3.2 Model of Permanent Magnet Synchronous Motor

The interesting fact about the mathematical model of permanent magnet synchronous motor (PMSM) in the d - q rotating frame is that the current and voltage variables are no longer sinusoidal signals. Instead, they are changed to DC signals. In this way, the reference signals in d - q rotating frame are capable to be constants or step signals, which explains why PI controllers are widely used for PMSM drive systems.

It is convenient to design a control scheme for PMSM by representing a PMSM model in a d - q rotating frame instead of a three-phase frame. The variables transformation is realized according to Clarke Transformation and Park Transformation, using the equations presented earlier in this chapter.

Mathematical models of the a PMSM in the d - q rotating frame can be represented as differential equations of stator variables, i.e.,

$$\frac{di_d}{dt} = -\frac{R_s}{L_d}i_d + \frac{L_q}{L_d}\omega_r i_q + \frac{1}{L_d}u_d \quad (3.16)$$

$$\frac{di_q}{dt} = -\frac{R_s}{L_q}i_q - \frac{L_d}{L_q}\omega_r i_d - \frac{1}{L_q}\omega_r \psi_f + \frac{1}{L_q}u_q \quad (3.17)$$

$$\frac{d\omega_r}{dt} = \frac{1}{T_M}[\psi_f i_q + (L_d - L_q)i_d i_q - t_l] \quad (3.18)$$

$$\frac{d\theta_r}{dt} = \omega_r \quad (3.19)$$

where

u_d : Stator voltage at to d axes.

u_q : Stator voltage at to q axes.

i_d : Stator current at to d axes.

i_q : Stator current at to q axes.

R_s : Stator resistances.

R_d : Rotor resistances at to d axes.

R_q : Rotor resistances at to q axes.

L_d : Rotor inductances at to d axes.

L_q : Rotor inductances at to q axes.

ω_r : Rotor angular speed

J: Moment of inertia

t_l : Load torque

T_M : Mechanical time constant

ψ_f : Permanent magnet flux

The scheme of the PMSM in a d - q frame is shown in Figure.3.3. In the PMSM, the main magnetic field is produced by permanent magnets. Those magnets are placed on the rotor. Assuming the stator current has no effect on the magnet field, the flux is constant during operation. However, in reality the stator current produces its own

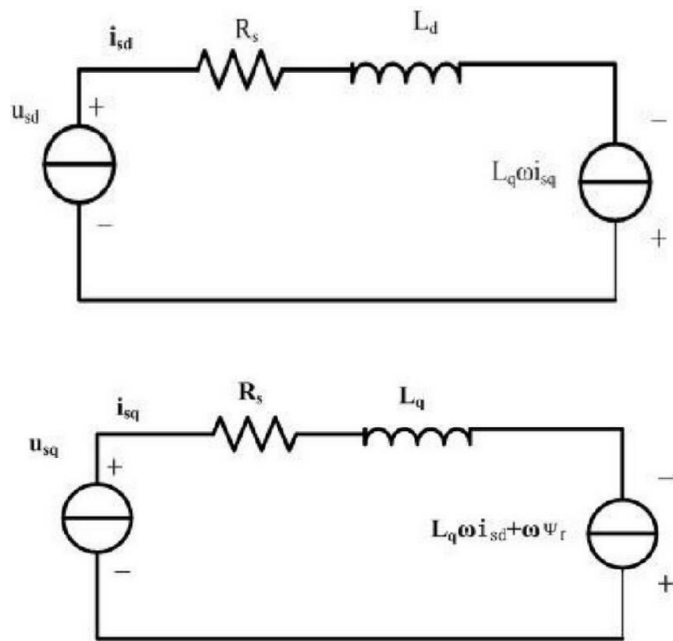

Figure 3.4 Scheme of the PMSM in a d - q frame.

magnetic field influencing the original one. This phenomenon is called armature reaction. Consequently, the stator flux consists of two fluxes.

$$\psi_d = L_d i_d + \psi_f \quad (3.20)$$

$$\psi_q = L_q i_q \quad (3.21)$$

where the stator leakage fluxes ψ_{ld} and ψ_{lq} satisfy

$$\psi_{ld} = L_d i_d \quad (3.22)$$

$$\psi_{lq} = \psi_q = L_q i_q \quad (3.23)$$

At no load condition, the armature reaction is usually neglected because of the very small amounts of stator current. The produced torque of a PMSM in the d - q frame is

$$T = \frac{3}{2} z_p \psi_f i_q \quad (3.24)$$

where

z_p is the number of pole pairs.

The maximum rotor speed can be identified as:

$$\omega_{max} = \frac{E_{max}}{\psi_s} \quad (3.25)$$

where

E_{max} : The maximum phase voltage in a PMSM.

ψ_s : Stator flux

ω_{max} : Maximum rotor speed for rated flux.

Higher rotor speed can be obtained by weakening the stator flux. An appropriate rotor speed and torque are decided by the stator current. That is why the stator current is control objective in the control system of PMSM.

CHAPTER 4

THIRD-HARMONIC INJECTION PULSE WIDTH MODULATION OF POWER ELECTRONIC INVERTER

4.1 Pulse Width Modulation

A Pulse Width Modulation (PWM) technique is increasingly used in a PMSM control system. It is a convenient and fast method to output AC signals with variable amplitude and frequency. PWM is usually classified in sinusoidal carrier-based PWM (SPWM) and space vector PWM (SVPWM). In the SPWM scheme, the three-phase modulating waves are compared with a triangular high frequency carrier to determine when an electronic switch is on or off. In the SVPWM scheme, an electronic switch is on when its leg average voltage vector is equal to the sampled reference vector in every switching period. Nowadays, SPWM is an important part of control system of PMSM in quadcopters. In this thesis, a PMSM control system take full advantage of SPWM.

An SPWM scheme includes a sinusoidal or cosine modulating signal and a high frequency carrier signal. Usually, a triangular wave is chosen as a carrier signal, as it offers good harmonic performance.

Nowadays, the transistor-based IGBT inverters are most commonly used. Here is an example to explain how a three-phase SPWM works. As shown in Figure 4.1, this is a DC/AC three-phase inverter model. Every IGBT is an electronic switch represented by S1 to S6. V_{dc} is a DC voltage source and the DC voltage will be transformed to AC voltage. Three-phase loads are represented by R-L1 to R-L3. They receive the three-

phase voltage from the inverters.

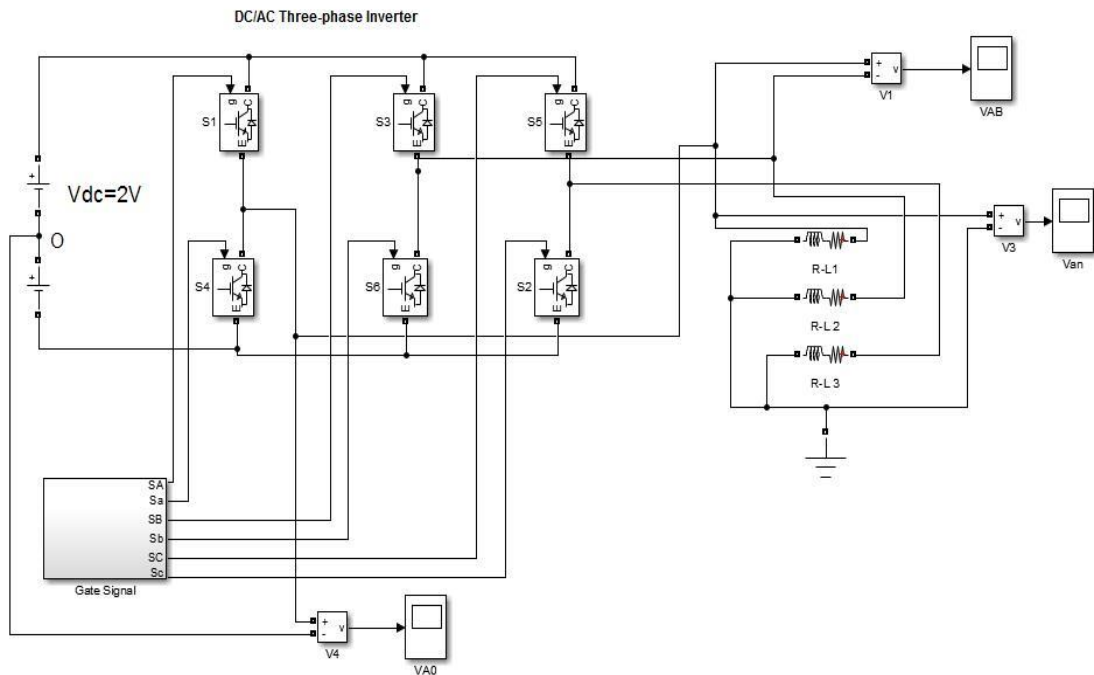

Figure 4.1 DC/AC three-phase inverter model.

The IGBT switches' gating signals are generated at the instant overlap of sinusoidal modulating signal and a triangular carrier signal. Phase A has upper switch S1 and lower switch S4. If the sinusoidal modulating signal amplitude V_s is more than

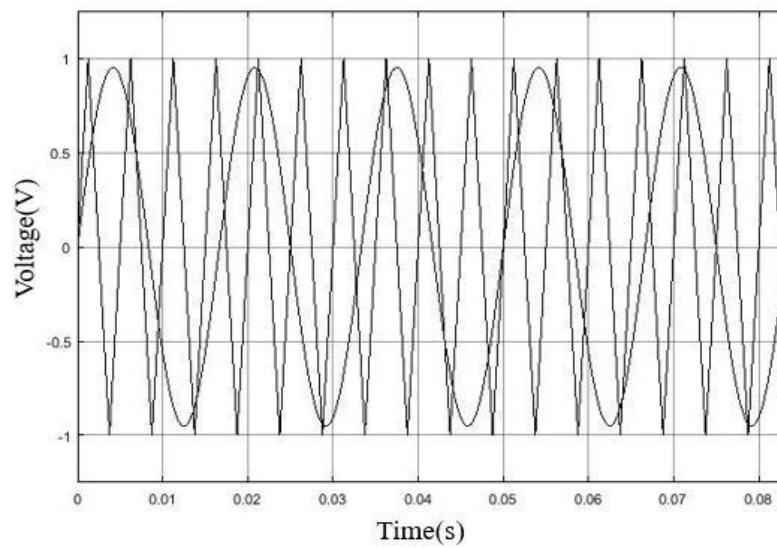

Figure 4.2 Modulating signal and carrier signal.

the carrier signal amplitude V_T , i.e. $V_s \geq V_T$, the upper switch S1 is on and lower switch S4 is off. If the former is less than the latter, the upper switch S4 is on and the upper switch S1 is off. The average leg voltage amplitude V_{AO} of the inverter is

$$V_{AO} = m \frac{V_{dc}}{2} \quad (4.1)$$

where m is a modulation index and V_{dc} is DC voltage.

In a three-phase SPWM system, leg voltages, phase-to-neutral voltages and line voltages are very important. Leg voltages V_{AO} , V_{BO} and V_{CO} are listed in Table 4.1. Phase-to-neutral voltages V_{An} , V_{Bn} and V_{Cn} are listed in Table 4.2. Line voltages V_{AB} , V_{BC} and V_{CA} are listed in Table 4.3.

Table 4.1 Leg voltages of three-phase SPWM

Switches On	Leg voltage V_{AO}	Leg voltage V_{BO}	Leg voltage V_{CO}
S1, S2, S5	$0.5V_{dc}$	$-0.5V_{dc}$	$0.5V_{dc}$
S1, S2, S6	$0.5V_{dc}$	$-0.5V_{dc}$	$-0.5V_{dc}$
S1, S2, S3	$0.5V_{dc}$	$0.5V_{dc}$	$-0.5V_{dc}$
S2, S3, S4	$-0.5V_{dc}$	$0.5V_{dc}$	$-0.5V_{dc}$
S3, S4, S5	$-0.5V_{dc}$	$0.5V_{dc}$	$0.5V_{dc}$
S4, S5, S6	$-0.5V_{dc}$	$-0.5V_{dc}$	$0.5V_{dc}$

In this example, $m=1$ and $V_{dc}=2V$. The V_{AO} amplitude is 1V. As shown in Figure 4.3, the V_{AO} curve is between -1V and 1V. V_{AO} is an AC waveform, which explains that the DC voltage is transformed to an AC voltage.

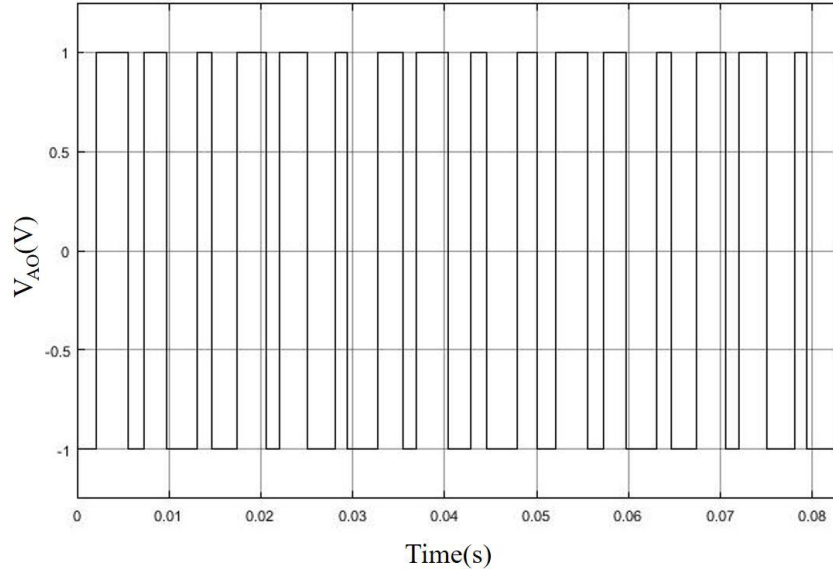

Figure 4.3 V_{AO} curve.

Table 4.2 Phase-to-neutral voltages of three-phase SPWM

Switches On	Phase-to-neutral voltage V_{An}	Phase-to-neutral voltage V_{Bn}	Phase-to-neutral voltage V_{Cn}
S1, S2, S5	$1/3 V_{dc}$	$-2/3 V_{dc}$	$1/3 V_{dc}$
S1, S2, S6	$2/3 V_{dc}$	$-1/3 V_{dc}$	$-1/3 V_{dc}$
S1, S2, S3	$1/3 V_{dc}$	$1/3 V_{dc}$	$-2/3 V_{dc}$
S2, S3, S4	$-1/3 V_{dc}$	$2/3 V_{dc}$	$-1/3 V_{dc}$
S3, S4, S5	$-2/3 V_{dc}$	$1/3 V_{dc}$	$1/3 V_{dc}$
S4, S5, S6	$-1/3 V_{dc}$	$-1/3 V_{dc}$	$2/3 V_{dc}$

In this example, $m=1$ and $V_{dc}=2V$. From the Table 4.2, we can calculate that

$\frac{1}{3}V_{dc}=\frac{2}{3}V$, $\frac{2}{3}V_{dc}=\frac{4}{3}V$, $-\frac{1}{3}V_{dc}=-\frac{2}{3}V$, and $-\frac{2}{3}V_{dc}=-\frac{4}{3}V$. As V_{An} curve is shown in Figure

4.4.

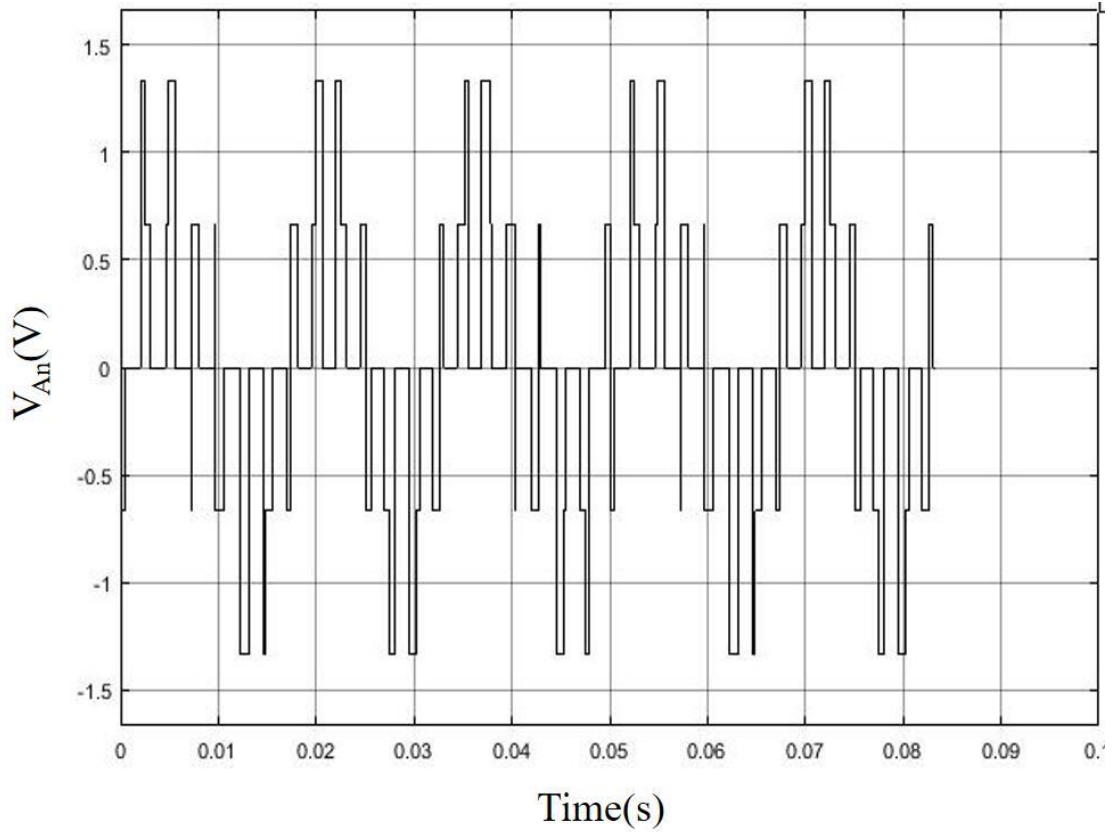

Figure 4.4 V_{An} curve.

Table 4.3 Line voltages of three-phase SPWM

Switches On	Line voltage V_{AB}	Line voltage V_{BC}	Line voltage V_{CA}
S1, S2, S5	V_{dc}	$-V_{dc}$	0
S1, S2, S6	V_{dc}	0	$-V_{dc}$
S1, S2, S3	0	V_{dc}	$-V_{dc}$
S2, S3, S4	$-V_{dc}$	V_{dc}	0
S3, S4, S5	$-V_{dc}$	0	V_{dc}
S4, S5, S6	0	$-V_{dc}$	V_{dc}

In this example, $m=1$ and $V_{dc}=2V$. From the Table 4.2, we can calculate that

$V_{dc}=2V$ and $-V_{dc}=-2V$. As V_{AB} curve is shown in Figure 4.5.

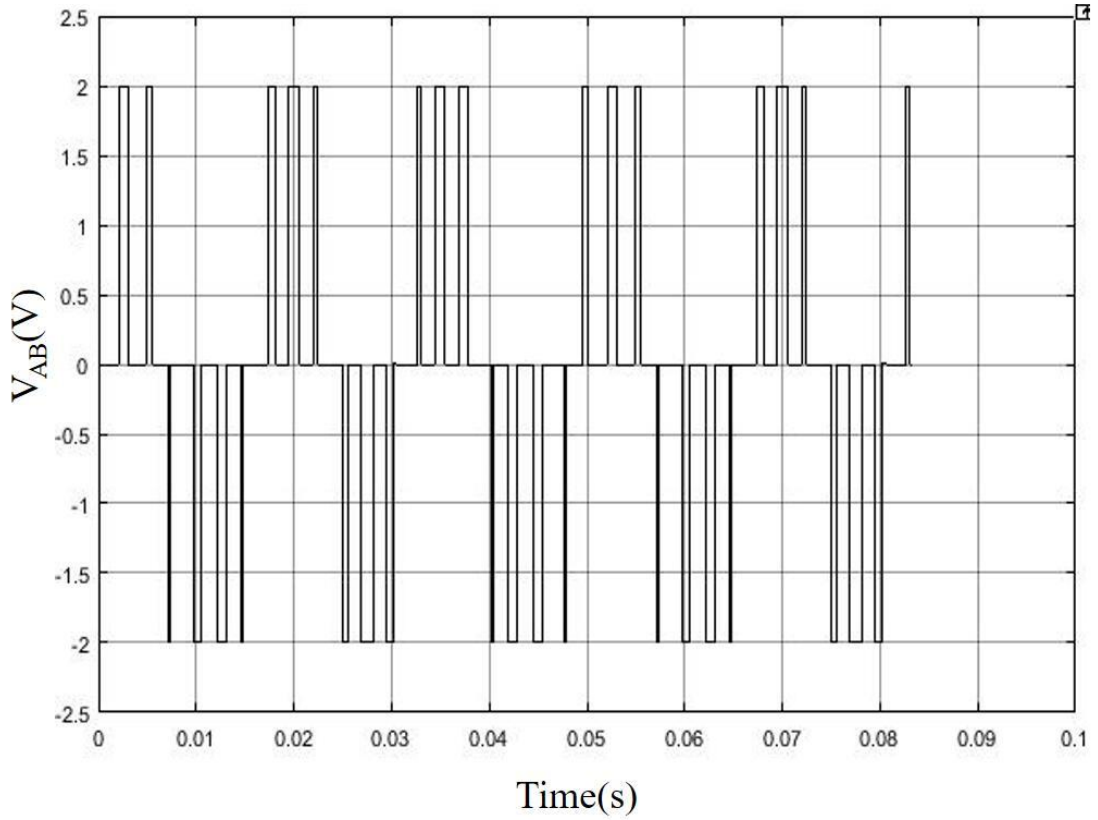

Figure 4.5 V_{AB} curve.

The output voltage of SPWM is limited to $0.5V_{dc}$. This voltage may be insufficient for a high-speed motor operation. To enhance the output voltage, third-harmonic is injected in the modulating signal.

4.2 Third-harmonic Injection Pulse Width Modulation

The three-phase modulating signals with injection of third-harmonic are

$$V_A = V_{A1} \sin(\omega t) + V_{A3} \sin(3\omega t)$$

$$V_B = V_{B1} \sin(\omega t) + V_{B3} \sin(3\omega t) \quad (4.2)$$

$$V_C = V_{C1} \sin(\omega t) + V_{C3} \sin(3\omega t)$$

As shown in Figure 4.6, sinusoidal modulating signals is added a third-harmonic and create a new resultant modulating signal. The peak value in the resultant modulating signal is less than the original sinusoidal modulating signal. That leads a higher output

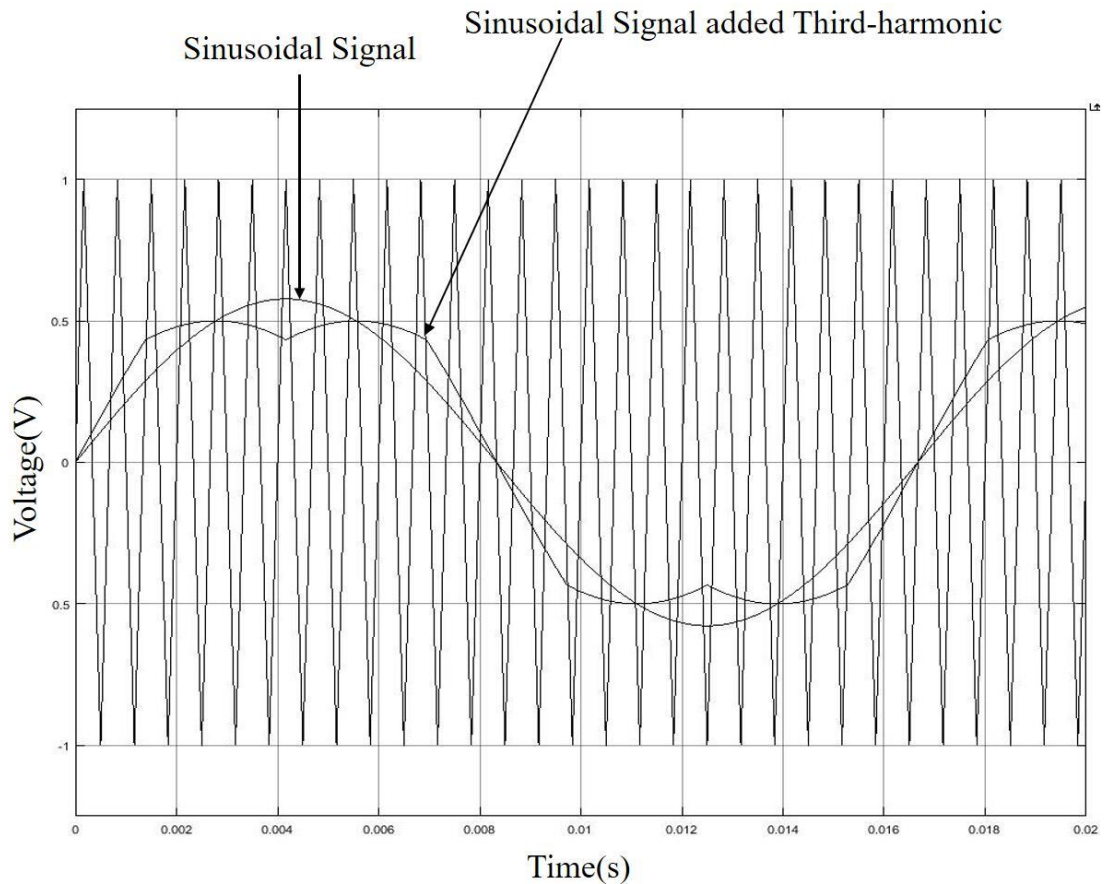

Figure 4.6 Sinusoidal modulating signals with injection of third-harmonic.

voltage at the inverter. The third-harmonic cancels out in the IGBT legs and does not appear in the output leg voltages. Thus, the output voltage does not contain the undesired low-order harmonic.

CHAPTER 5

FIELD ORIENTED CONTROL OF PERMANENT MAGNET SYNCHRONOUS MACHINE

5.1 The Principle of Field Oriented Control

Dated back to the beginning of 1970s, the principle of torque and flux control called ‘field oriented control ’or ‘vector control’ was introduced. This control method was firstly used for induction machines and later for synchronous machines. The essential idea relies on the use of alternating current (AC) machine stator current space vectors to control an AC machine in a similar way to a direct current (DC) machine.

Most types of AC motors cannot be controlled as easily as DC motors. To design an AC motor model, the magnetic flux and torque should be decoupled for maintaining linearity between input and output. The dynamic models of AC machines are nonlinear and more complex than those of DC machines.

It is possible to solve this problem by using space vector representations of AC machines. The field oriented control methods allow representation of AC machines to obtain control linearity, decoupling, and high performance drives. This method was first formulated by Blaschke [13]. Field oriented control aims to decouple torque and flux.

It is easy to decouple flux and torque for DC motors. But it is not so simple for AC motors. For example, in squirrel cage AC motors, the only current signal would be received is stator current signal because the rotor current is not accessible. The torque

production depends on the armature current and machine flux. Keeping constant flux would build a linear relationship between motor and armature current. However, using stator current to calculate flux will lead to a nonlinear flux and torque. In this way, linear control of torque is difficult to achieve.

By using a vector control AC motor model, torque can be controlled separately from the flux. In this way, decoupled control between the two subsystems is achieved when the flux is kept constant.

5.2 Basic Field Oriented Control of PMSM Scheme

This thesis focuses on using field oriented control for a permanent magnet synchronous motor (PMSM). The model of PMSM is discussed in Chapter 3. Figure 5.1 describes the basic scheme of vector control of a PMSM. In a typical PMSM drive system, PMSM three phase currents are measured. The measured currents are transformed using the

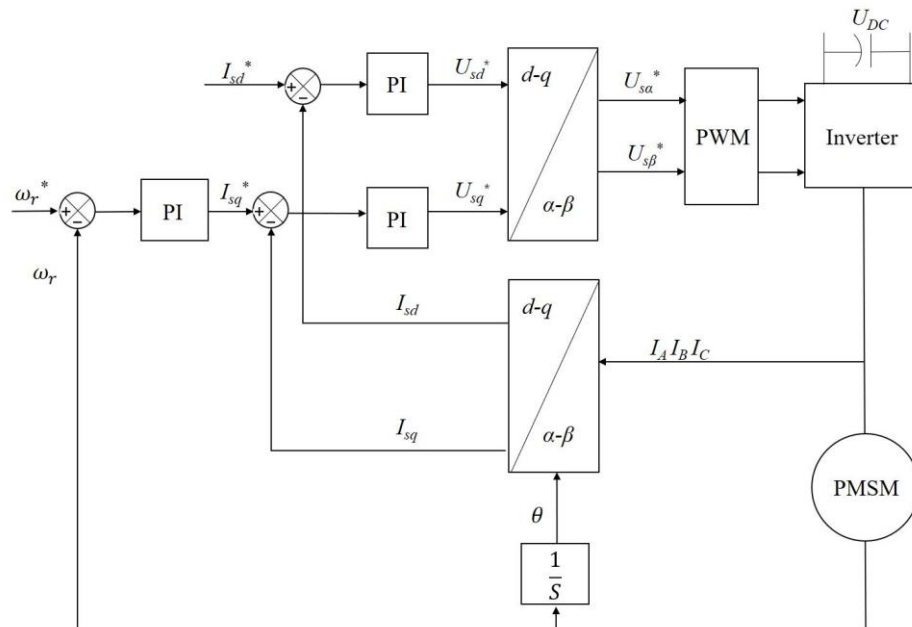

Figure 5.1 Field oriented control of PMSM scheme.

Clarke transformation into a stationary frame (α - β) $I_{s\alpha}$ and $I_{s\beta}$. These two currents then are transformed into rotating frame (d - q) I_{sd} and I_{sq} . The PI controllers compare the command values with the measured values to judge the operation condition.

The outputs of the controllers are transformed from a rotating frame to stationary frame by using the Park transformation. The commanded signals of the vector are sent to the pulse width modulation (PWM) block.

Previously, field oriented control is not used together with PWM in quadrotors as shown in the Figure 5.2 shown. The dynamic response of this control system is not as good as field oriented control with PWM. For this reason, field oriented control and

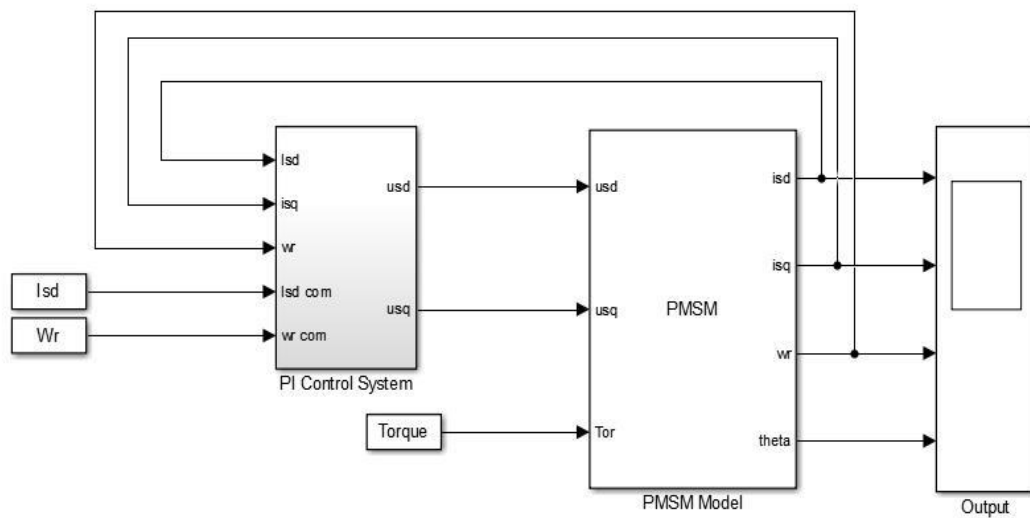

Figure 5.2 Field oriented control without PWM scheme.

PWM are always used together at present. However, inverters would create undesired harmonic in the circuit by using PWM. Harmonic could bring unsatisfied dynamic response such as speed ripple. To overcome this problem, this thesis proposes a third-harmonic method injection PWM method. The simulation results of third-harmonic

injection PWM field oriented control of PMSM and traditional field oriented control are compared. This comparison proves that third-harmonic injection PWM field oriented control of PMSM provides a faster dynamic response and reduced the speed ripples during operation.

CHAPTER 6

REALIZATION OF FIELD ORIENTED CONTROL OF PERMANENT MAGNET SYNCHRONOUS MACHINE WITH THIRD-HARMONIC INJECTION PULSE WIDTH MODULATION

6.1 Simulation of FOC of PMSM with Third-Harmonic Injection

Quadcopters' autonomous operations mostly depend on the dynamic responses of their motors. This chapter focuses on the realization of field oriented control (FOC) of permanent magnet synchronous machine (PMSM) with third-harmonic injection pulse width modulation (PWM) by using MATLAB/Simulink. The simulation result is compared with FOC of PMSM without third-harmonic injection PWM. The comparison proves that FOC of PMSM with third-harmonic injection PWM will provide a faster dynamic response and reduces the speed ripple during operation. Using the FOC of PMSM allows similar dealings with the motor as with a direct current (DC) motor. The produced torque of motor could be presented as

$$t_e = \frac{3Z_p}{2} [\psi_f i_q + (L_d - L_q) i_d i_q] \quad (6.1)$$

where Z_p is the number of pole pairs in a PMSM.

The scheme of FOC of PMSM with third-harmonic injection PWM is shown in the Figure 6.1. It consists of a PMSM model and control system in the d - q rotating frame connected with the rotor spend loop.

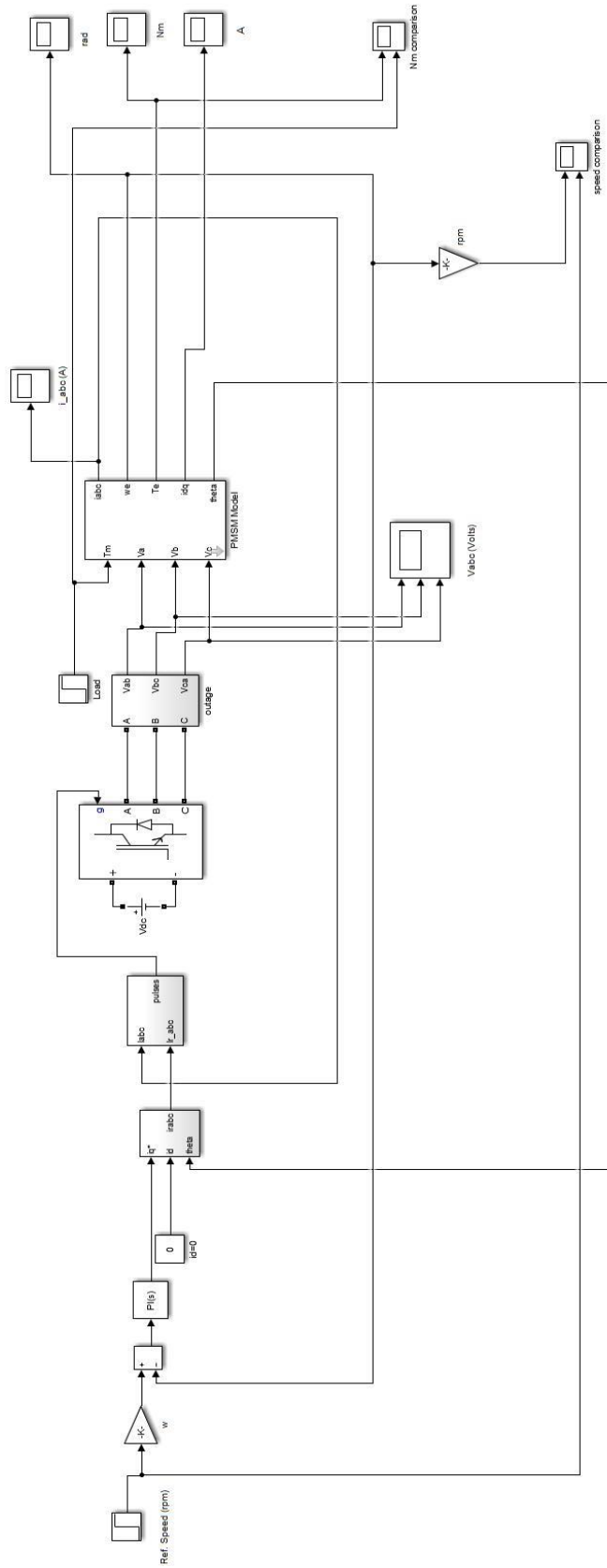

Figure 6.1 Scheme of FOC of PMSM with third-harmonic injection PWM.

Keeping $i_{sd} = 0$ is the common control for PMSM. It helps protect the motor against under or over excited conditions.

The PMSM in the $d-q$ rotating frame is given in chapter 2. The essential process is using third-harmonic injection PWM to create inverters' gate signals. This is shown in Figure 6.2. The block a, block b and block c are three phase sinusoidal currents to generate a third-harmonic. Then this third-harmonic is injected to the original sinusoidal three-phase current. The ' \geq ' blocks represent the electronic switches. The principle of PWM to control electronic switches is given in chapter 4.

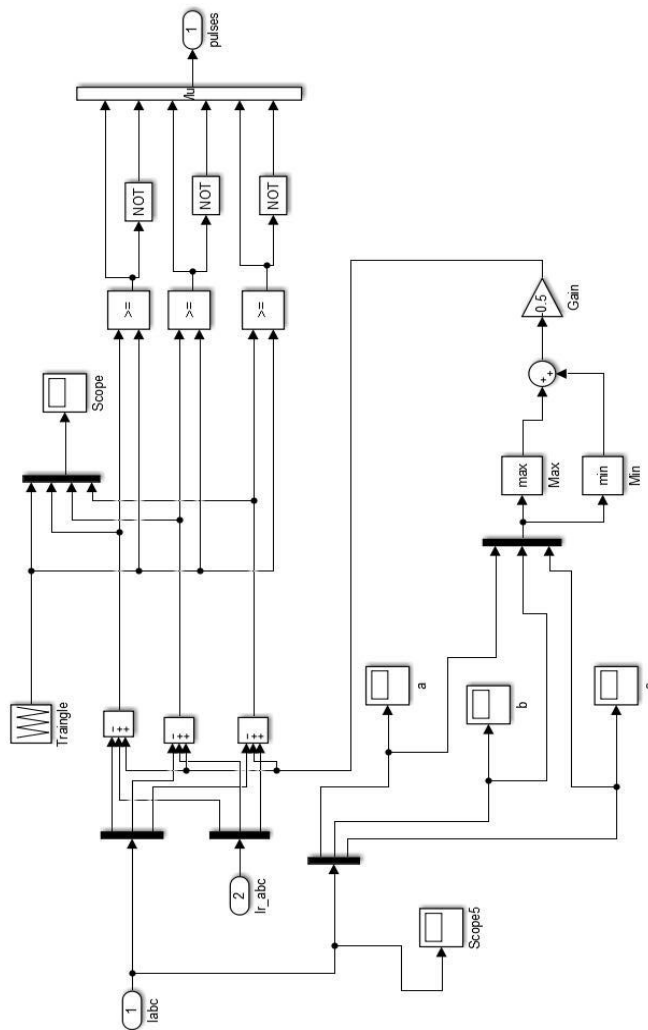

Figure 6.2 Third-harmonic injection PWM injection.

The simulation result of FOC of PMSM with third-harmonic injection PWM is given in Figure 6.3. The PMSM parameters are shown in Table 6.1. We want to adjust the speed fast while reducing speed ripples.

Table 6.1 PMSM parameters

Parameter	Value	Unit
Stator Resistance	1.5	Ohm
Inductance L_d	0.007	H
Inductance L_q	0.0058	H
Inertia	0.0038	Kg*m ²
Friction Viscous Gain	0.00035	Nm/rad/s
Flux	0.1546	Wb
Torque	7	Nm
Number of Poles	6	P
DC Source	50	V

At first, the command speed is set to 500 rpm and the load torque is 10 Nm. Simulation stop time is 0.2s. The blue curve represents the command speed and the red one represents the real speed response. In the [0.01,0.015] interval, the peak value of the red curve is 575 rpm and the minimal value is 386 rpm. The biggest difference value between them is 189 rpm. After 0.04s, the speed becomes stable obviously. The torque

response is shown in Figure 6.4. After 0.1s, the torque is stable. Figure 6.5 shows the two phase currents I_d and I_q in a $d-q$ rotating frame.

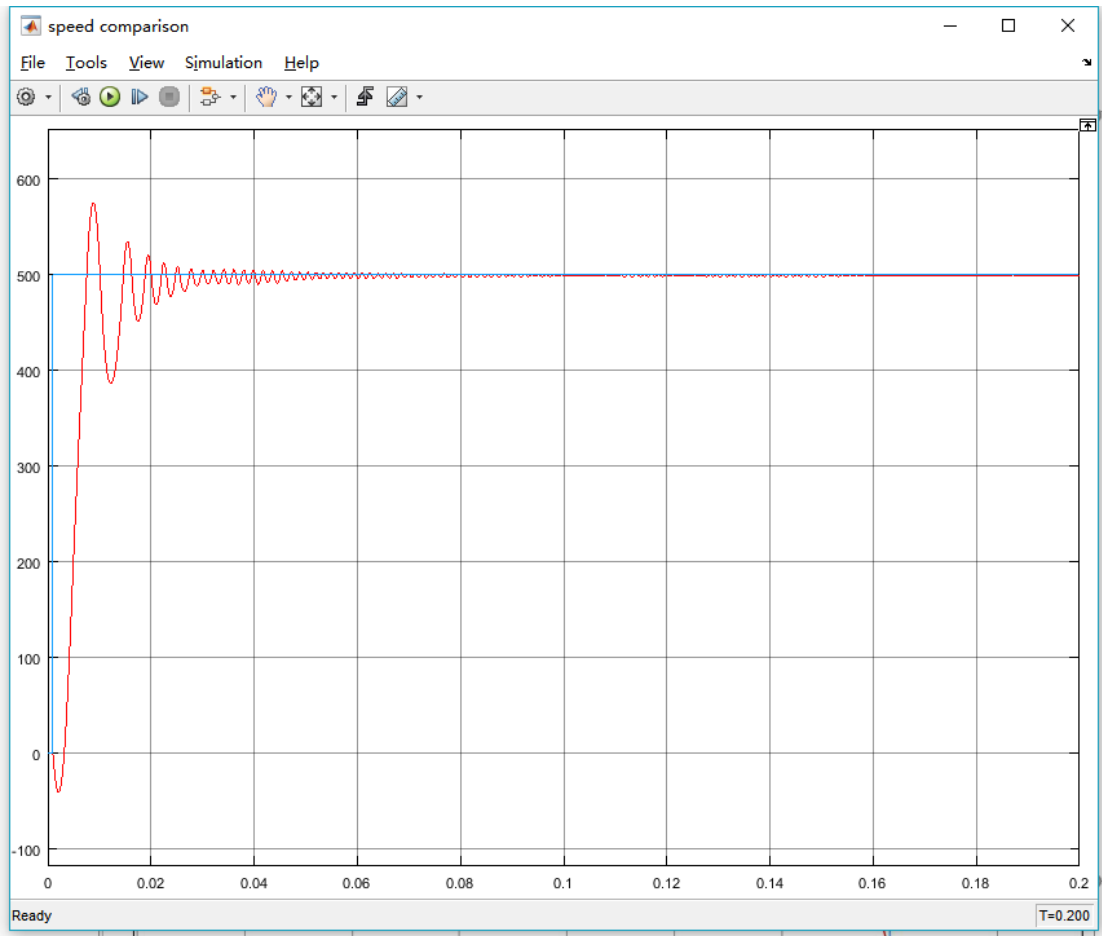

Figure 6.3 500 rpm speed response.

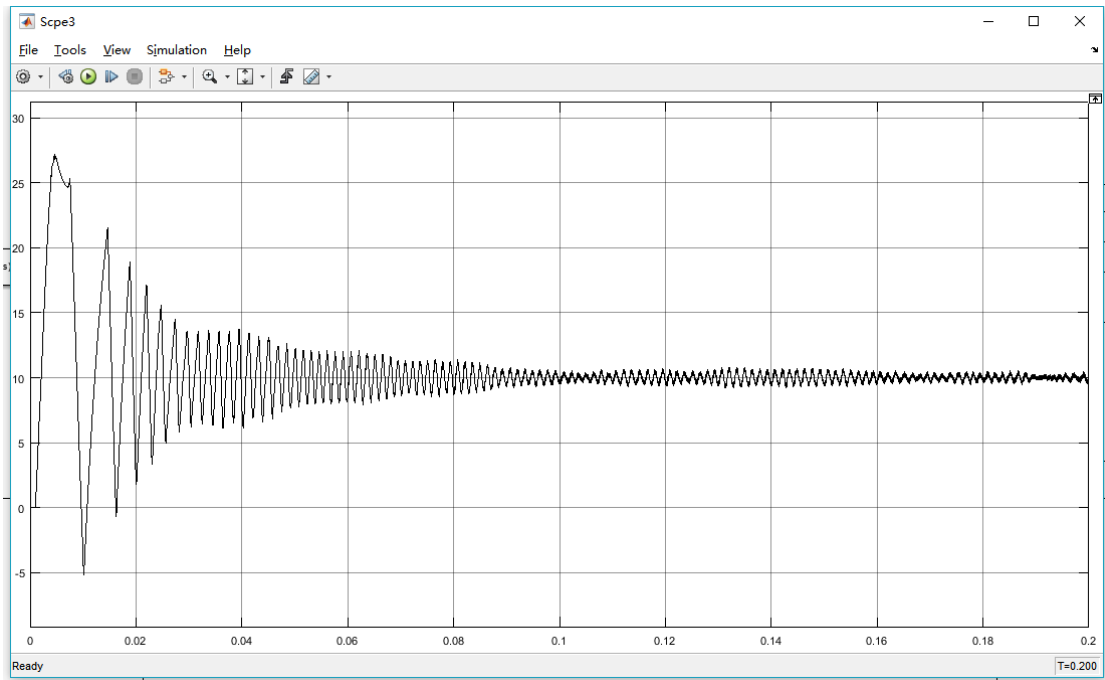

Figure 6.4 500 rpm torque response.

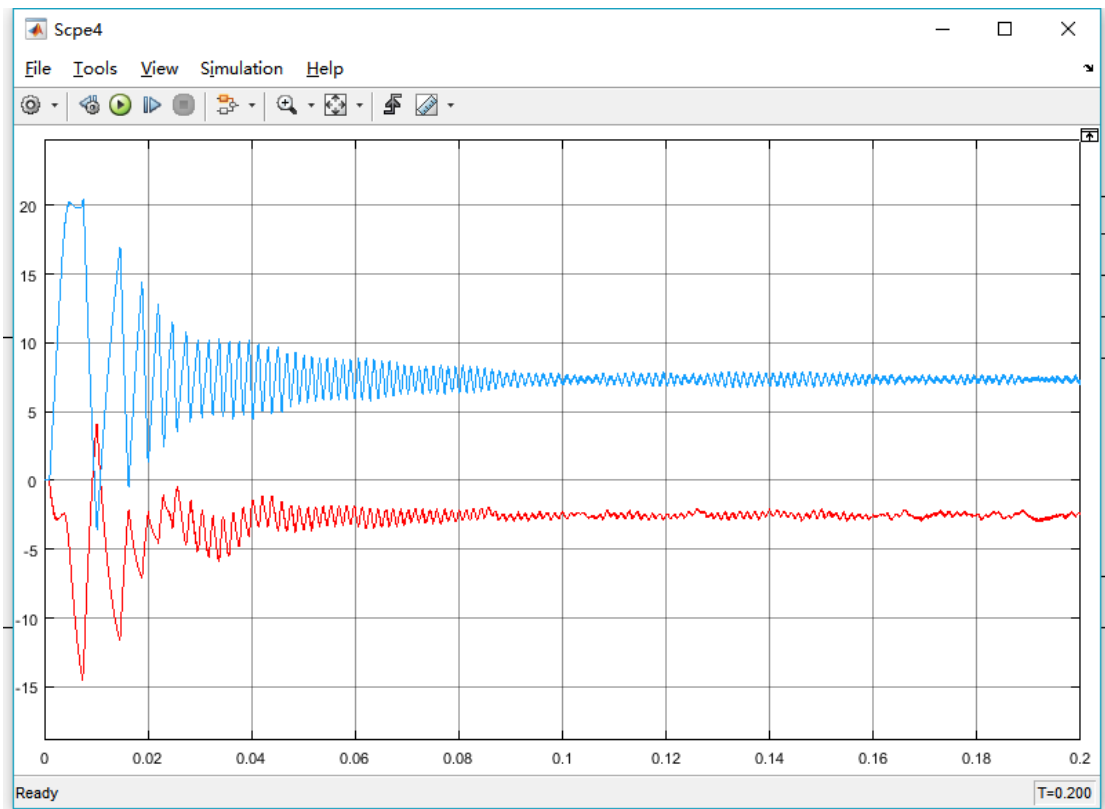

Figure 6.5 I_d and I_q in a d - q rotating frame.

The three-phase currents are calculated by I_d and I_q . When the quadcopter is in a stable operation, the output currents of PMSM should look like three-phase sinusoidal curves, as shown in Figure 6.6.

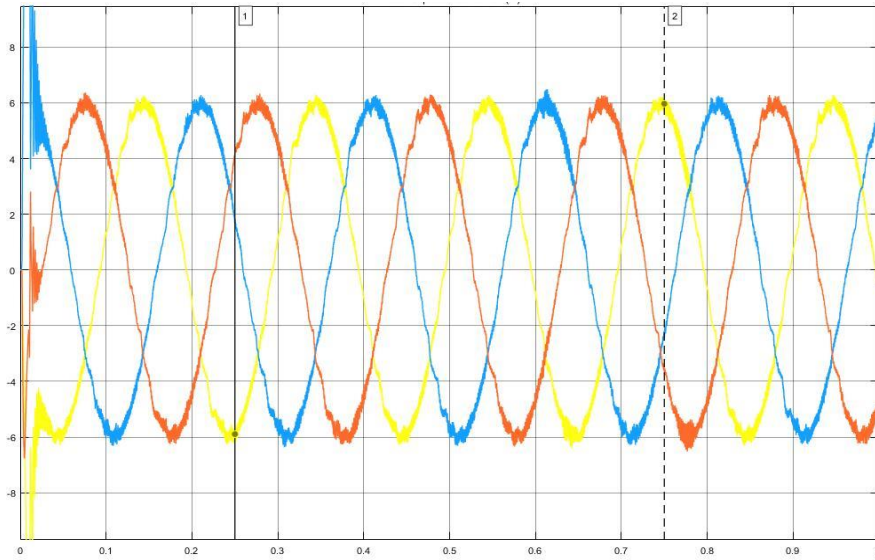

Figure 6.6 Three-phase currents curves.

Also, the quadcopter should have an ability to adjust speed quickly. Figure 6.7 shows the simulation result. The speed is changed to 500 rpm from 1000 rpm at 0.1s. The speed ripples reduced quickly from 0.1 to 0.16s obviously.

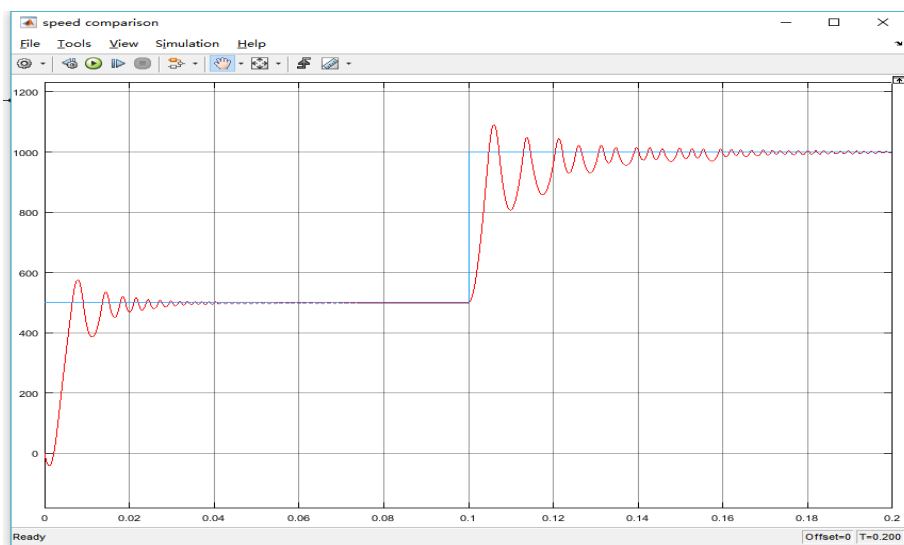

Figure 6.7 Speed changes from 500 rpm to 1000 rpm.

6.2 Comparison of Simulation of FOC of PMSM with Third-Harmonic Injection and Traditional FOC of PMSM

To compare the FOC of PMSM with third-harmonic injection and traditional FOC of PMSM, quadrotor's practical operations are simulated in MATLAB. As we known, a quadrotor can move in vertical direction and horizontal direction. This thesis focuses on controlling a quadrotor's movement in vertical direction. Because researching on controlling a quadrotor's horizontal movements needs more knowledge of aerodynamics besides electrical engineering. Future work will relate to the quadrotor's movement in a horizontal direction.

Figure 6.8 shows the quadrotor's vertical ascending motion scheme. Increasing the output power of four motors at the same time, the total tension created by motors is getting bigger. When the total tension is enough to overcome the weight of the quadrotor, the quadrotor will rise vertically from the ground.

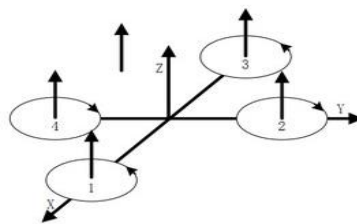

Figure 6.8 Quadrotor's rising vertical motion scheme.

FOC of PMSM with three-harmonic injection to realize a quadrotor's vertical ascending motion is simulated, as shown in Figure 6.9. This result is compared to traditional FOC of PMSM, as shown in Figure 6.10. The PMSM speed is set to 1500rpm.

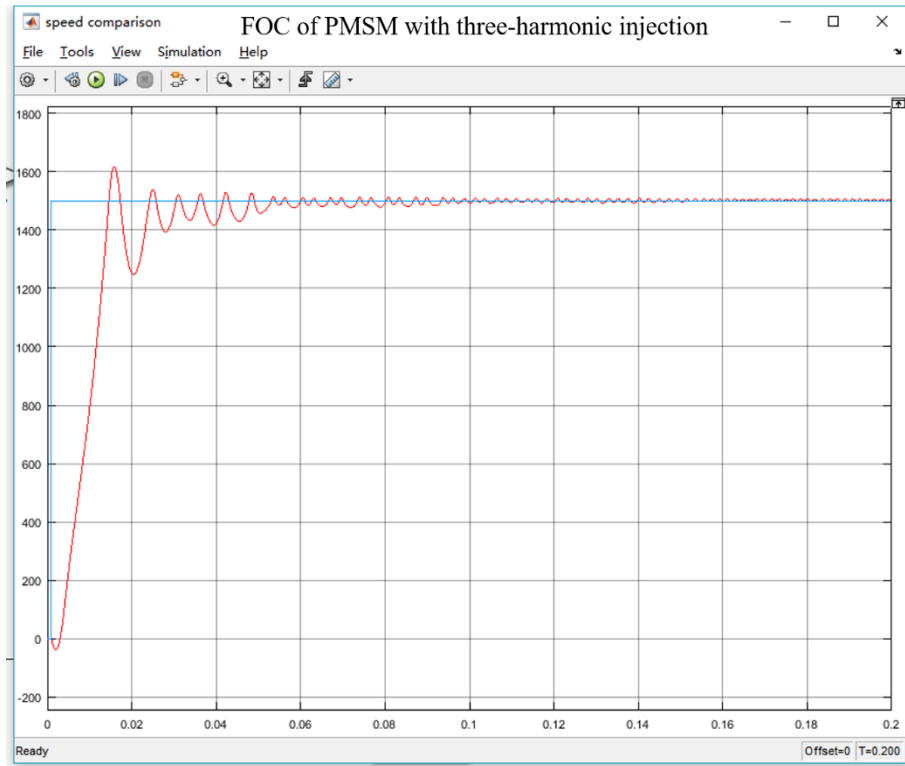

Figure 6.9 1500rpm with FOC of PMSM with three-harmonic injection.

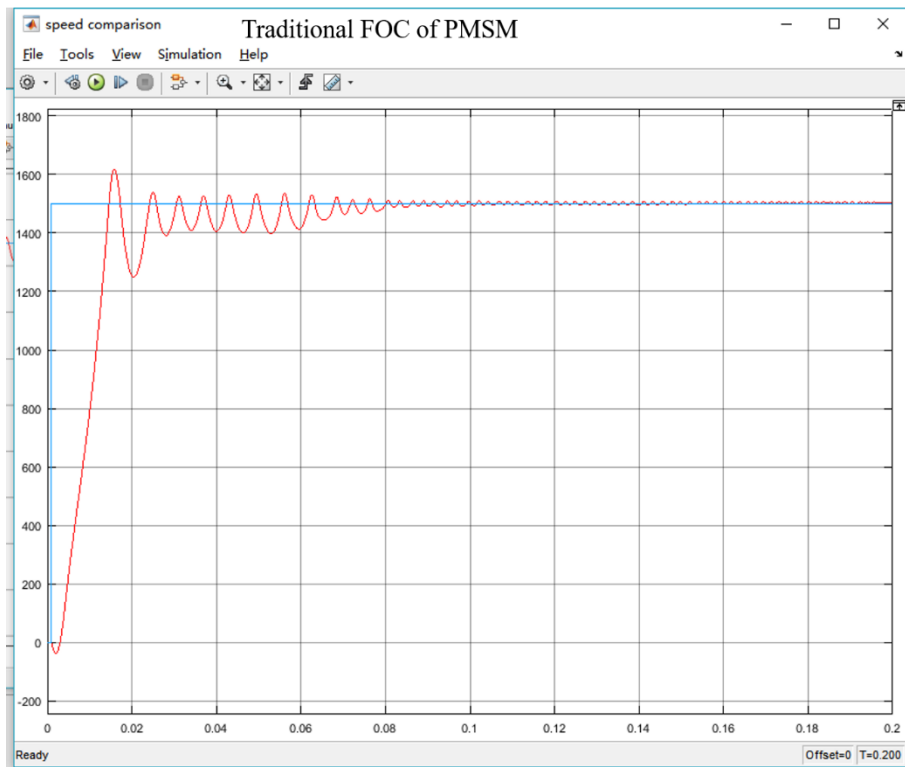

Figure 6.10 1500rpm with traditional FOC of PMSM.

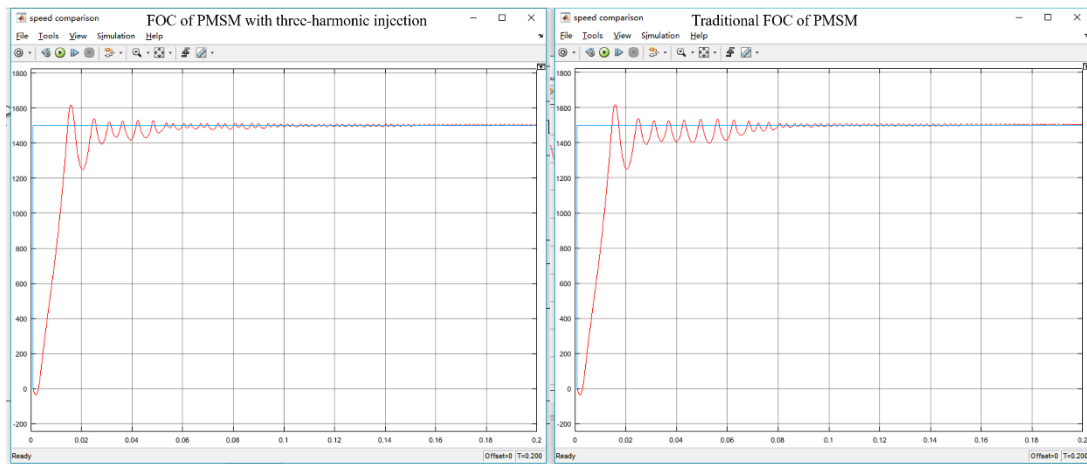

Figure 6.11 Comparison two control methods at 1500rpm.

To compare these two results fairly, Figure 6.9 and Figure 6.10. are set in same size. As shown in Figure 6.11, in interval $[0.04,0.06]$, traditional FOC of PMSM has more speed ripples. That means FOC of PMSM with three-harmonic injection reduces the motor speed ripples quickly. After 0.06s, the motor is stable by using FOC of PMSM with three-harmonic injection. Tradition FOC of PMSM needs more 0.02s to make the motor stable. From this comparison, we can find that FOC of PMSM with three-harmonic injection not only has a better dynamic response than traditional FOC of PMSM but also reduce the motor speed ripples.

Then we try to increase the speed quickly from 500rpm to 1500rpm at 0.1s. In this way, a quadrotor has an accelerating rising velocity. The simulations of two control methods are shown in Figures 6.12-6.13.

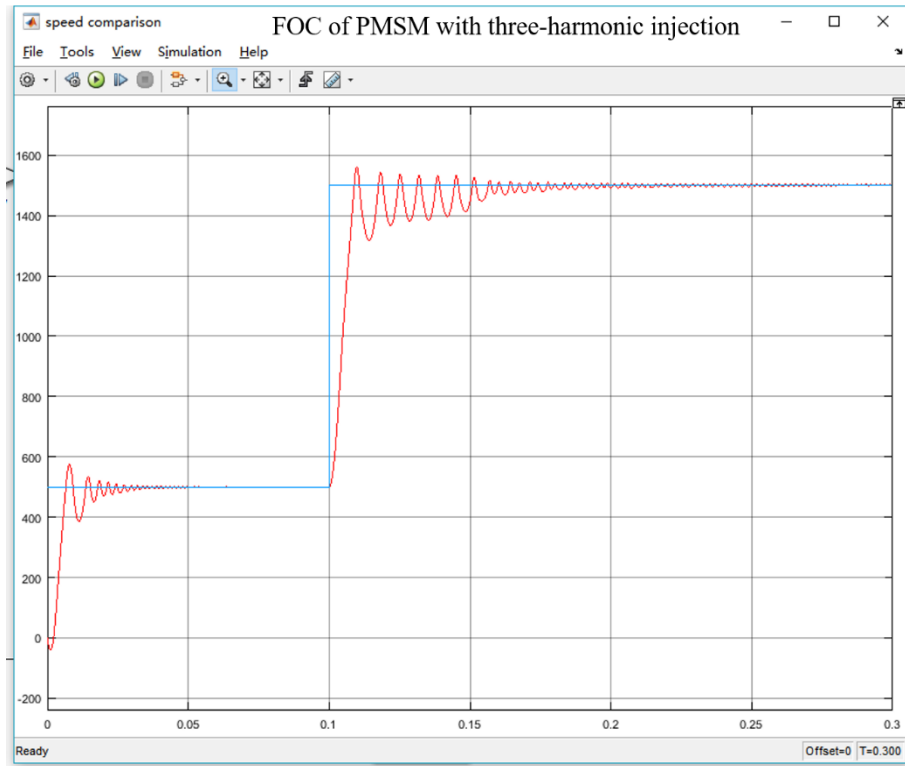

Figure 6.12 From 500rpm to 1500rpm with FOC of PMSM with three-harmonic injection.

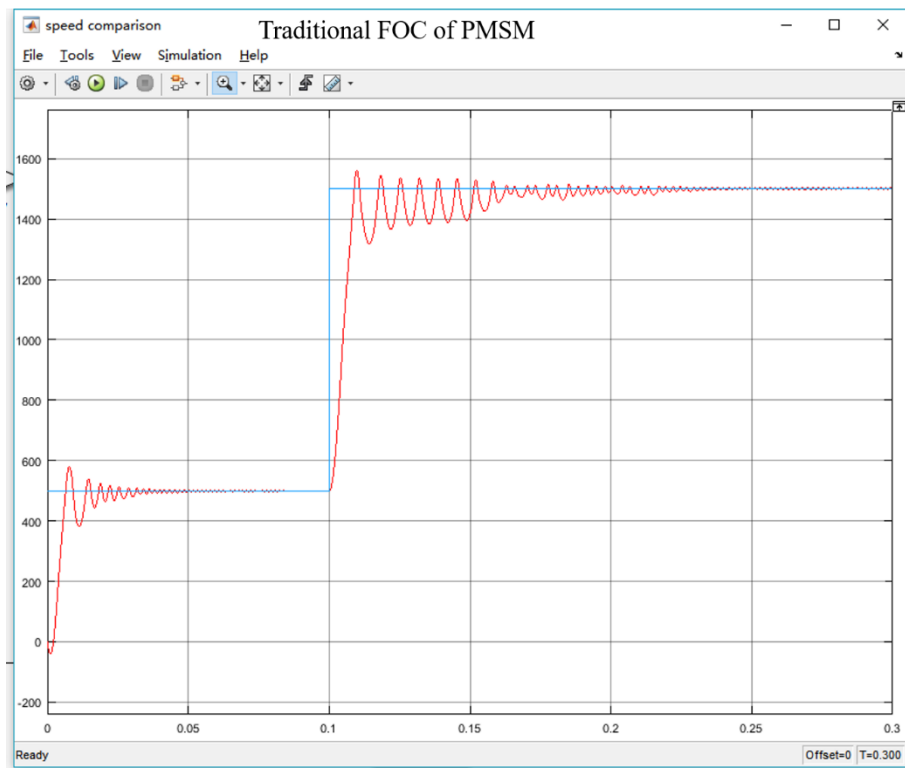

Figure 6.13 From 500rpm to 1500rpm with traditional FOC of PMSM.

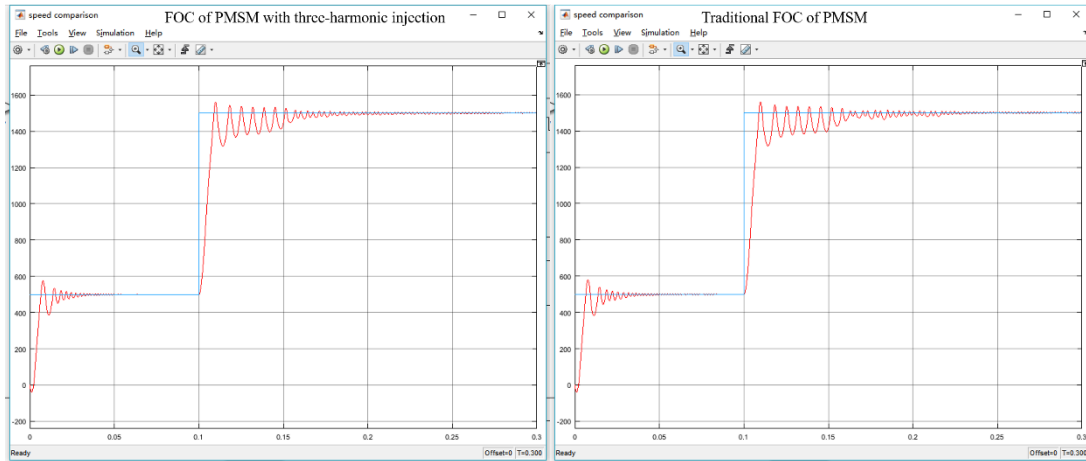

Figure 6.14 Comparison between two control methods at from 500rpm to 1500rpm.

Traditional FOC of PMSM creates more red curve ripples in interval $[0.05,0.1]$ and $[0.04,0.06]$. After 0.2s, motor is stable by using FOC of PMSM with three-harmonic injection. Traditional FOC of PMSM makes a motor stable after 0.25s. This comparison shows that FOC of PMSM with three-harmonic injection still has a better dynamic response with fewer speed ripples when the motor speed is changed quickly.

Sequentially changing rising velocity randomly and quickly is a challenge to control a quadrotor. FOC of PMSM with three-harmonic injection can satisfy this high requirement. The simulation result is also compared that with traditional FOC of PMSM. The motor speed is set to 500rpm at the beginning and then changed to 1000rpm, 1500rpm, 800rpm and back to 500rpm every 0.2 second.

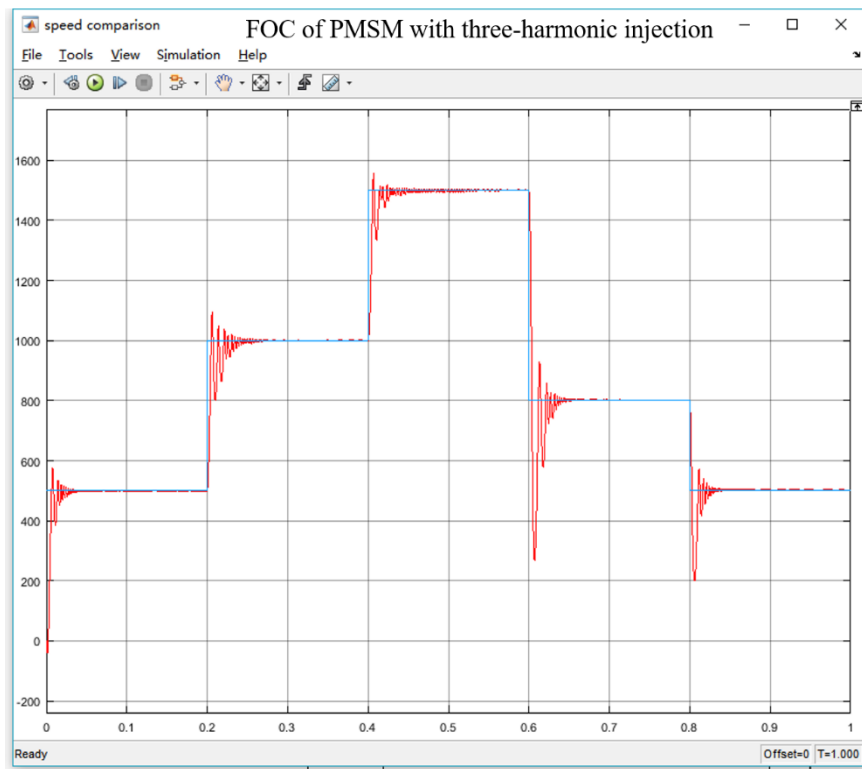

Figure 6.15 Random speed with FOC of PMSM with three-harmonic injection.

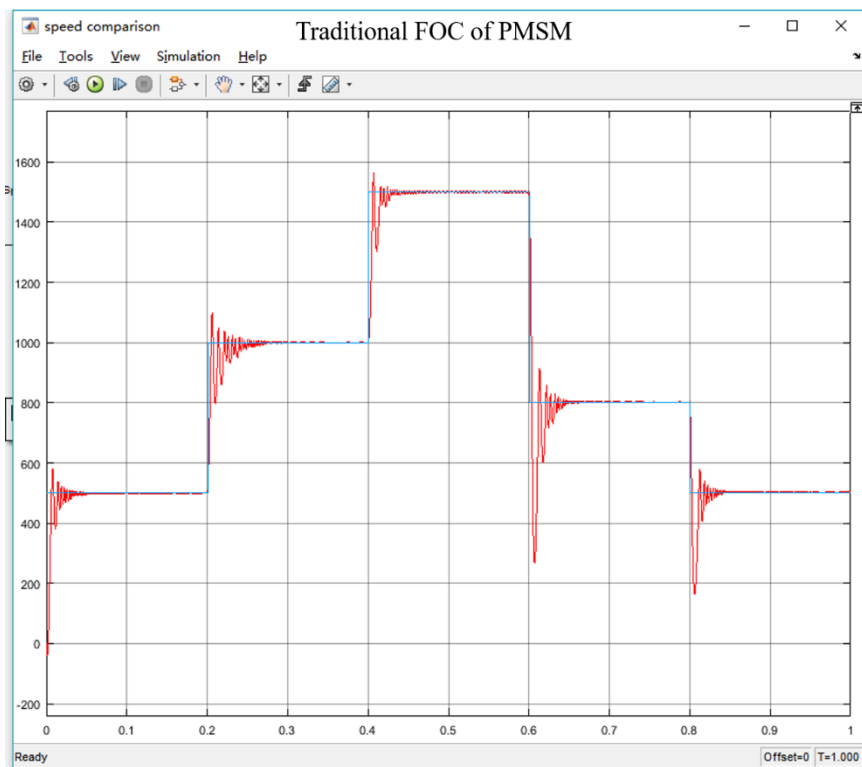

Figure 6.16 Random speed with traditional FOC of PMSM.

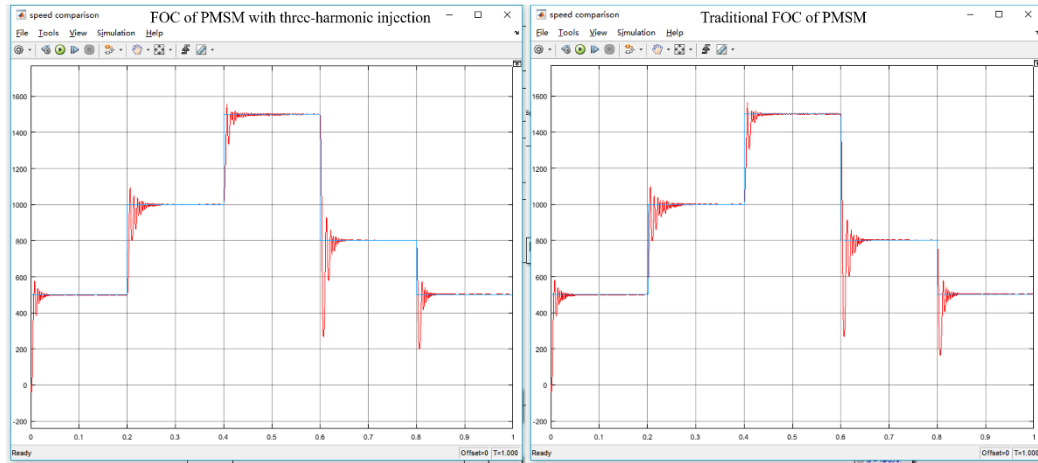

Figure 6.17 Comparison between two control methods at random motor speed.

In intervals $[0.2,0.4]$, $[0.4,0.6]$ and $[0.6, 0.8]$, we can recognize that the red curve created by resulting from traditional FOC of PMSM has more ripples obviously. In this complex situation, FOC of PMSM with three-harmonic injection still have a better dynamic response with fewer speed ripples

On the other hand, landing is as important as rising for a quadrotor. However, a quadrotor cannot land at a high speed. It depends on the height from the ground and other environmental conditions. Basically, a quadrotor should decelerate gradually during landing. Simulation results of the two control methods are shown in Figure 6.18. The motor speed is set to decelerate 100rpm every 0.2 second. The two FOC methods have a similar dynamic response in this situation.

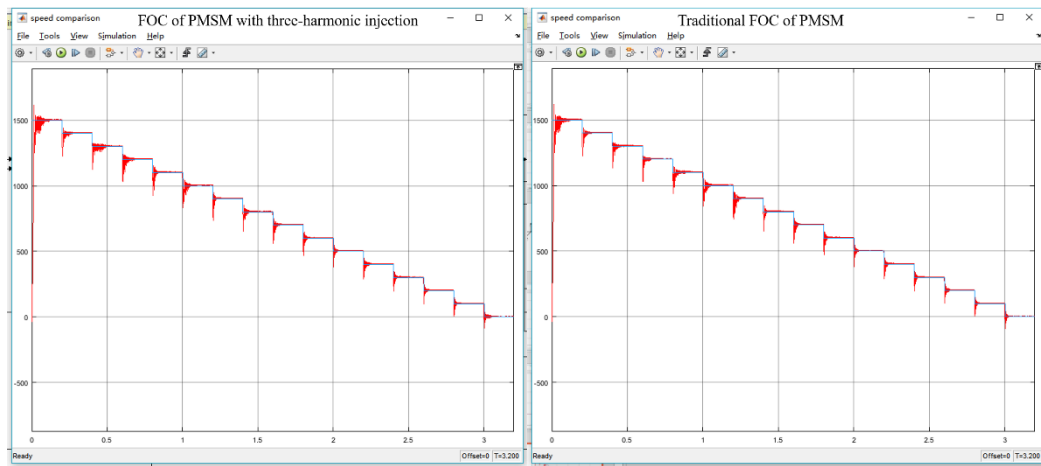

Figure 6.18 Motor speed reduction by the two control methods.

Chapter 7

CONCLUSION

7.1 Contributions of This Thesis

The selection of a control method for a quadrotor depends on its types of motors. The latest quadrotors are using permanent magnet synchronous motors. This thesis makes the following contributions.

(1) Making literature review about field oriented control, permanent magnet synchronous motor and pulse width modulation.

Field oriented control is an effective and convenient method for such motors. It aims to decouple torque and flux of a permanent magnet synchronous motor. This method allows representation of AC machines to obtain control linearity, decoupling, and high performance drives. To simplify the model of a permanent magnet synchronous motor, Clark transformation and Park transformation are introduced. Then the control objects are changed to two-phase stator currents in a $d-q$ frame instead of the three-phase stator currents. Pulse width modulation changes a Direct Current (DC) voltage to an Alternating Current (AC) voltage to supply the permanent magnet synchronous motor installed in a quadrotor.

(2) Proposing the method: field oriented control with third-harmonic injection PWM

To improve control quality will often develop a traditional control system. The

method proposed in this thesis has developed a power electronic scheme for the traditional field oriented control. Third-harmonic is injected to sinusoidal modulating signals to create a new resultant modulating signal. The cost of the control system may be raised because of extra power electronic devices. The results of field oriented control with third-harmonic injection PWM have resulted in a better dynamic response than the traditional one. In addition, it can reduce the speed ripples for permanent magnet synchronous motors. Thus, this method can satisfy a quadrotor's high requirements of fast and precise control.

7.2 Limitations and Future Work

In this thesis, only the vertical motion is considered for a quadrotor. The future work will include controlling a quadrotor in a horizontal direction. Aerodynamics have to be considered in order to build a control model for a quadrotor. A more complex control system is expected. Also, obstacle avoidance is a hot topic to study. It is the task of satisfying a quadrotor to non-intersection or non-collision position constraints. Image processing should be implemented in the control system to realize this operation.

REFERENCES

- [1] T.C. Martin, "The Inventions, Researches and Writings of Nikola Tesla," New York: *Electrical Engineer*, 1894, pp. 9-11
- [2] Electro-magnetic motor US 381968 A
- [3] Zhu, Z. Q. (2011) Recent advances on Permanent Magnet machines including PM technology. *Keynote Lect. IEEE IEMDC*, 15-18 May, Niagara Falls.
- [4] Jahns, T. M. and Owen, E. L. (2001) AC adjustable-speed drives at the millennium: How did we get here? *IEEE Trans. Power Elect.*, **6**(1), 17-25.
- [5] Hava, A. M., Kerkman, R. S., and Lipo, T. A. (1997), A high performance generalized discontinuous PWM algorithm. *IEEE APEC*, **2**, 886-891.
- [6] Ojo, O. (2004) The generalized discontinuous PWM scheme for three phase voltage source inverters. *IEEE Trans. Ind. Elect.*, **51**(6), 1280-1289.
- [7] Mohan, N. (2001) *Electric Drives an Integrative Approach*, 2nd ed, MNPERE, Minneapolis.
- [8] Bose, B. K. (2006) *Power Electronics and Motor Drives: Advances and Trends*. Amsterdam, Academic Press, Elsevier.
- [9] Leonhard, W. (2001) *Control of Electrical Drives*. Berlin, Springer.
- [10] Krishnan, R. (2001) *Electrical Motor Drives: Modeling, Analysis and control*. Prentice Hall.
- [11] Chiasson, J. (2005) *Modeling and High Performance Control of Electric Machines*. Chichester, John Wiley & Sons.
- [12] Kovacs, K. P. and Racz, I. (1959) *Transiente Vorgange in Wechselstrommaschinen*. Budapest, Akad. Kiado.
- [13] Blaschke F. (1971) Das Prinzip der Feldorientierung, die Grundlage fur Transvector-regelung von Drehfeld-maschine, *Siemens Z*, **45**, 757-760
- [14] Texas Instruments Europe (1998) *Field Oriented Control of 3-phase AC-Motor*. Texas Instruments, inc.
- [15] Mohan, N. (2001) *Advanced Electric Drives Analysis, Control, and Modeling using Simulink*. MNPERE, Minneapolis.