

Copyright Warning & Restrictions

The copyright law of the United States (Title 17, United States Code) governs the making of photocopies or other reproductions of copyrighted material.

Under certain conditions specified in the law, libraries and archives are authorized to furnish a photocopy or other reproduction. One of these specified conditions is that the photocopy or reproduction is not to be “used for any purpose other than private study, scholarship, or research.” If a user makes a request for, or later uses, a photocopy or reproduction for purposes in excess of “fair use” that user may be liable for copyright infringement,

This institution reserves the right to refuse to accept a copying order if, in its judgment, fulfillment of the order would involve violation of copyright law.

Please Note: The author retains the copyright while the New Jersey Institute of Technology reserves the right to distribute this thesis or dissertation

Printing note: If you do not wish to print this page, then select “Pages from: first page # to: last page #” on the print dialog screen



The Van Houten library has removed some of the personal information and all signatures from the approval page and biographical sketches of theses and dissertations in order to protect the identity of NJIT graduates and faculty.

ABSTRACT

PERFORMANCE OF MULTI-USER CODES IN WIRELESS COMMUNICATIONS

**by
Muhammad Tauseef Ulislam**

Multi-user codes are a widely used in transmitting user data from base station to mobile station and vice versa. In wireless communications a signal received by a mobile station goes through different fading channels resulting. These multi-paths add constructively and destructively with different delays and attenuation at the mobile station. The autocorrelation and cross correlation properties of the Multi-user codes play a significant role in extracting the user data from the signal corrupted by multipath fading channel.

The thesis presents a comparison of different Multi-user codes based on their autocorrelation and cross correlation properties. These codes are passed through a multipath fading models and their performance is evaluated based on the Bit Error Rate (BER). The performance for the Multi-user codes is compared both in synchronous and asynchronous mode of transmission to the base station. The model used for simulating multipath fading channel is Clark model.

**PERFORMANCE OF MULTI-USER CODES IN WIRELESS
COMMUNICATIONS**

by
Muhammad Tauseef Ulislam

**A Thesis
Submitted to the Faculty of
New Jersey Institute of Technology
in Partial Fulfillment of the Requirements for the Degree of
Master of Science in Electrical Engineering**

Department of Electrical and Computer Engineering

May 2005

Blank Page

APPROVAL PAGE

**PERFORMANCE OF MULTIUSER CODES IN WIRELESS
COMMUNICATIONS**

Muhammad Tauseef Ulislam

Dr. Ali N. Akansu, Thesis Advisor
Professor of Electrical and Computer Engineering, NJIT

Date

Dr. Alexander M Haimovich, Committee Member
Professor of Electrical and Computer Engineering, NJIT

Date

Dr. Yun-Qing Shi, Committee Member
Professor of Electrical and Computer Engineering, NJIT

Date

BIOGRAPHICAL SKETCH

Author: Muhammad Tauseef Ulislam

Degree: Master of Science

Date: May 2005

Undergraduate and Graduate Education:

- Master of Science in Electrical Engineering,
New Jersey Institute of Technology, Newark, NJ, 2005
- Bachelor of Engineering in Computer System Engineering,
National University of Sciences and Technology, Pakistan, 2002

Major: Digital Signal Processing

To my mother for her unconditional love,
To my father for his guidance,
To my brother, my sister and my friends for their encouragement and support.

ACKNOWLEDGEMENT

I would like to express my deepest appreciation to Dr. Ali N. Akansu, who not only served as my research supervisor, providing valuable and countless resources, insight, and intuition, but also constantly gave me support, encouragement, and reassurance. Special thanks are given to Dr. Richard Haddad and Dr. Ali Abdi for actively participating in my committee.

Many of my senior colleagues in the Center for Communications and Signal Processing Research Laboratory are deserving of recognition for their support. I would like to thank my senior colleague Radharani Poluri for her immense help during practical difficulties.

TABLE OF CONTENTS

Chapter	Page
1 INTRODUCTION.....	1
1.1 Overview of Multi-user Codes.....	1
1.2 Overview of Fading Models.....	2
1.3 Motivation and Related Work.....	3
1.4 Organization.....	4
2 MULTI-USER CODES.....	5
2.1 Gold Codes.....	6
2.1.1 AutoCorrelation and Cross Correlation Properties	6
2.1.2 Gold Codes Generation.....	6
2.2 Walsh Codes.....	7
2.2.1 AutoCorrelation and Cross Correlation Properties	8
2.2.2 Walsh Codes Generation.....	8
2.3 PN Codes.....	9
2.3.1 AutoCorrelation and Cross Correlation Properties	10
2.3.2 PN Codes Generation.....	11
2.4 Orthogonal Codes.....	11
2.4.1 AutoCorrelation and Cross Correlation Properties	11
3 CHANNEL MODELS.....	13
3.1 Small and Large Scale Fading Models.....	13
3.2 Outdoor Fading Models.....	14

TABLE OF CONTENTS
(Continued)

Chapter	Page
3.3 Indoor fading models.....	14
3.4 Types of Small Scale Fading Models.....	15
3.5 Fading Models Based on Statistical Analysis.....	16
3.6 Clarks Model.....	17
4 PERFORMANCE OF MULTI-USER CODES IN FADING MODELS.....	20
4.1 Effect of Code Length.....	20
4.2 Effect of Number of Users.....	25
4.3 Effect of Different Noise Generators.....	28
4.4 Effect of Multipah.....	29
5 CONCLUSION AND FUTURE WORK.....	36
APPENDIX MATLAB CODE.....	37
REFERENCES	39

LIST OF FIGURES

Figure		Page
1.1	Small scale and large scale fading.....	3
2.1	Time domain representation of PN, Walsh, Gold and new Orthogonal codes.....	5
2.2	Auto Correlation and Cross Correlation properties of Gold Codes.....	7
2.3	Auto Correlation and Cross Correlation properties of Walsh Codes.....	9
2.4	Auto Correlation and Cross Correlation properties of PN Codes.....	10
2.5	Auto Correlation and Cross Correlation properties of Orthogonal Codes..	12
3.1	Rayleigh fading simulator.....	17
3.2	Simulator using quadrature amplitude modulation with a) RF Doppler filter and b) baseband Doppler filter.....	18
3.3	Frequency domain implementation of a Rayleigh fading simulator at baseband.....	19
4.1	Synchronous fading results for 7 bit Gold and orthogonal codes and 8 bit Walsh, PN codes under AWGN.....	21
4.2	Synchronous fading results for 7 bit Gold and orthogonal codes and 8 bit Walsh, PN codes under AWGN.....	22
4.3	Asynchronous 7 bit Gold, 7 bit Walsh, 8 bit Orthogonal under AWGN...	23
4.4	Asynchronous,16 bit Walsh, 16 bit orthogonal codes under AWGN.....	24
4.5	Asynchronous, 31 bit Gold, 31 bit Orthogonal, 32 bit Walsh under AWGN.....	25
4.6	Asynchronous 7 bit Gold, 7 bit Orthogonal, 8 bit Walsh, 4 users.....	26
4.7	Asynchronous 16bit codes 4 users under AWGN.....	27
4.8	Asynchronous 31 bit Orthogonal codes with 4 users.....	28
4.9	Asynchronous, 7 bit Orthogonal under Rayleigh noise.....	29

LIST OF FIGURES
(Continued)

Figure		Page
4.10	Real part of Gaussian noise for Clarke model.....	30
4.11	Imaginary part of Gaussian noise.....	31
4.12	Histogram of the envelope as compared to the rayleigh distribution.....	32
4.13	Two users with two multi-path in AWGN.....	33
4.14	Two users with two multi-path in Rayleigh.....	34
4.15	Four users with four multi-paths in AWGN.....	35

CHAPTER 1

INTRODUCTION

1.1 Overview of Multi-user Codes

There has always been an effort to utilize the wireless channel in an efficient way. Different schemes have been out there to share this resource efficiently among different users. The traditional way of sharing this resource was time division multiplexing. The channel was broken down in different time slots. Each user was allowed to transmit data in that particular time.

There is a dual relationship between time and frequency. The next method that emerged was using the same channel in frequency. A particular bandwidth was allocated to a group of users. Each user was given allotted a particular frequency. Multiple users could access the same resource at same time but with different frequencies.

The above two techniques were used for a long time until emerge of Code Division Multiple Access (CDMA). There came up an idea of utilizing both frequency and time. Every user was allocated a user code which came out from a set of orthogonal codes. All the users utilized available channel bandwidth. Multiple users can transmit at the same time. When the signal is received at the receiver, it consists of noise, data transmitted by multiple users and the different multi-paths of the transmitted signal with different delays. The user code is multiplied with the received signal and the data of the particular user is extracted by the receiver who knows the user code. A by product of CDMA system is the inherent security. Only the user who has got the right code can extract the data from the received signal. If correct user code is not available, multiplying the data with the received signal results in noise. CDMA suppresses noise and

interferences. Since the signal occupies the full bandwidth of the channel, the jamming signals, which attack a particular frequency range, fail to destroy the signal. This inherent security property of CDMA plays makes it very popular.

1.2 Overview of Fading Models

Wireless channels are extremely random and are difficult to model. There are a lot of factors which play an important role in determining the response of a channel at a particular time. The channel impulse response is time varying. The factors that play an important role in determining the time varying nature of the channel are speed of the mobile, speed and position of the surrounding objects, location of the mobile with respect to the base station, scattering effects due to sharp objects etc.

The fading models can be divided into two broad categories namely large scale and small scale fading. Large scale fading takes into consideration the distance of the mobile from the base station. Large scale fading is primarily based on the free propagation model as mentioned in [1]. This model determines the local average power at a particular place with respect to base station. The average power is a function of distance from the base station.

Small scale fading takes into account the rapid fluctuations induced by varying conditions at the receiver. When an object is moving with a certain velocity, Doppler frequency drifts the actual frequency. Similarly at a particular point of time and location, there are variable numbers of multi-paths received by the mobile station. Doppler shift and multi-paths combine together and make the channel a time varying filter.

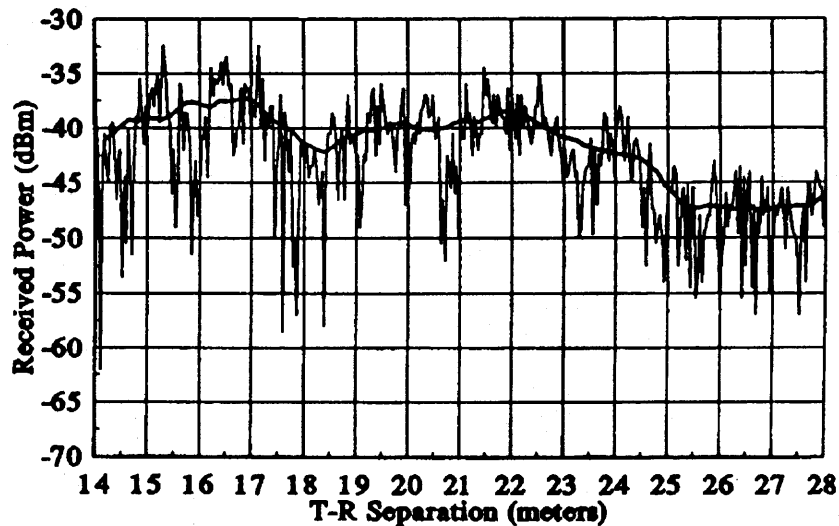

Figure 1.1 Small scale and large scale fading.
Source: Rappaport [1]

Figure 1.1 illustrates the small scale and large scale fading effect. The large scale fading effect can be seen as a function of distance where as small scale fading is the rapid fluctuation of the signal at around the large scale fading curve.

1.3 Motivation and Related Work

The thesis is built on the work done by [6] and [7]. It includes verification of these results proposed for the new orthogonal codes. The verification portion was tested only under AWGN and the results were compared with Gold, Walsh and PN codes. Extension to the work is testing these new codes for multi-user and multipath fading models. The wireless channel takes into account signals coming from Rayleigh, Rician or AWGN with different delays and attenuation. Different Fading models were studied and Clarke's model was implemented. It has been shown that the new proposed codes have better autocorrelation and cross correlation properties and they outperform other codes.

1.4 Organization

This thesis aims to carry out tests for the performance of user codes under AWGN and multipath fading models and compare these results with the already existing multi-user codes such that Gold, Walsh and PN codes. Chapter 1 of the thesis gives an overview of Multi-user codes and their importance in wireless communication. It is followed by the overview of challenges for wireless fading channel models. Chapter 2 talks about Gold, Walsh, PN and orthogonal codes in detail. Autocorrelation and cross correlation properties of these codes are discussed in detail. Chapter 3 discusses fading models. Fading models have been categorized into two main types, namely small scale fading and large scale fading. Different outdoor and indoor fading models based on empirical and experimental results are outlined. A brief discussion of some other fading models based on statistical data such that Nakagami, Weibull and Clarke model is also included. Chapter 4 talks about the performance of multi user codes in AWGN and Clark models. Different results are compared and analysis is provided. Chapter 5 ends with conclusion and future work. Source code is included in the Appendix.

CHAPTER 2

MULTI-USER CODES

This chapter looks at the cross correlation and auto correlation properties of Gold, Walsh, PN and Orthogonal codes. Theory behind generation of these codes is discussed. A comparison is made for 7 bit gold, 7 bit PN, 8 bit Walsh and 8 bit orthogonal codes. Later in the Chapter 4, a performance testing for higher bit length of these codes under Rayleigh and AWGN wireless channels is carried out. The time domain plots of these multi-user codes are show in the Figure 2.1.

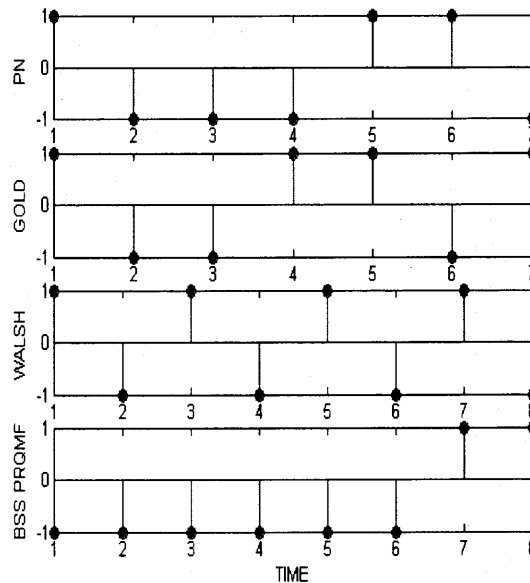

Figure 2.1 Time domain representation of PN, Walsh, Gold and new Orthogonal codes.
Source: Radha [6]

2.1 Gold Codes

Gold codes are pseudo random codes used in reverse link according to IS-95 specs. These codes exhibit good cross correlation and auto correlation properties and are a preferred choice for an asynchronous communication.

2.1.1 Gold Codes Generation

Gold codes are formed from maximum length codes. Gold codes are generated by linearly combining two maximal length sequences. These m-sequence codes are formed using feedback shift registers. Their values are shifted at every clock pulse. Operations like modulo-2 are performed to get the preferred codes.

2.1.2 Auto Correlation and Cross Correlation Properties

Maximum length codes have property that their autocorrelation function consists of two levels as mentioned in [3]. In our tests, gold codes were compared with other user codes. The autocorrelation and cross correlation properties for the 7 bit Gold codes are as shown in the figure 2.2

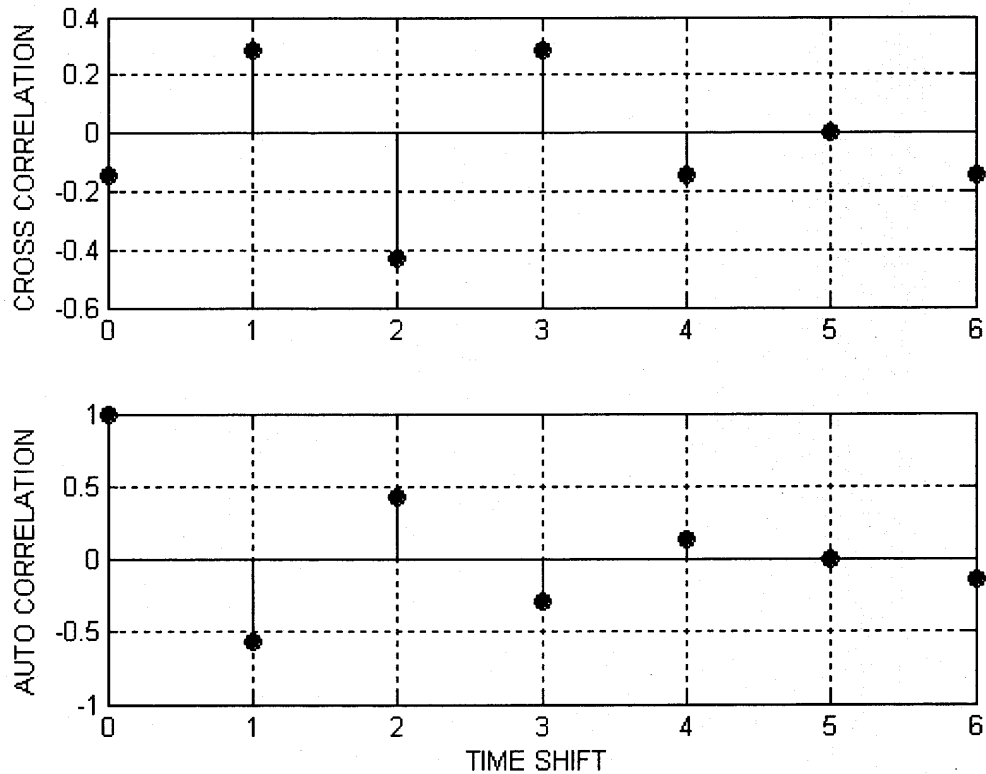

Figure 2.2 Auto Correlation and Cross Correlation properties of Gold Codes.
Source: Radha [6]

2.2 Walsh Codes

Walsh codes are orthogonal codes and find its application mostly in Image processing applications. Walsh codes are used in the forward link of a CDMA system. A Walsh code set has got a DC component which makes it very suitable for image processing applications.

2.2.1 Walsh Codes Generation

Walsh codes are also called Walsh-Hadamard codes. These matrices are generated as follows. Consider a matrix

$$H_0 = [1]$$

$$H_1 = \begin{bmatrix} H_0 & H_0 \\ H_0 & \overline{H_0} \end{bmatrix}_{4 \times 4}$$

Similarly, H_2 is formed by

$$H_2 = \begin{bmatrix} H_1 & H_1 \\ H_1 & \overline{H_1} \end{bmatrix}_{8 \times 8}$$

The first row of the Walsh codes is a DC component. Each row of the matrix forms a user code.

2.2.2 Auto Correlation and Cross Correlation Properties

Walsh code auto correlation and cross correlation properties are shown in the figure below. When compared to Gold codes, Walsh codes autocorrelation decays slower and has a slower rate of convergence. Gold codes possess better autocorrelation function and are functions of choice for asynchronous communication.

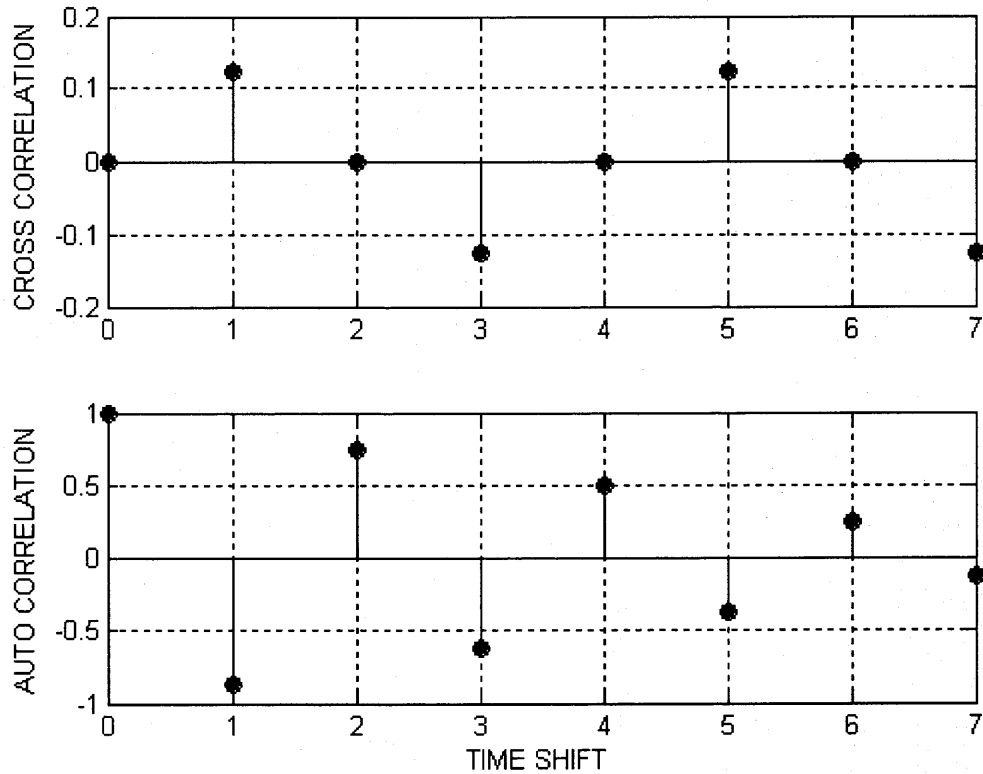

Figure 2.3 Auto Correlation and Cross Correlation properties of Walsh Codes.

2.3 PN Codes

PN codes are also called pseudorandom codes. These are used in spreading and despreading the transmitted signal. PN code is not a truly random and its future values can be predicted. It is a deterministic signal. However, it has statistical properties of white noise. This is the reason these codes are called pseudo random.

2.3.1 Auto Correlation and Cross Correlation Properties

The three basic properties of PN codes as mentioned in [2] are

1) Balance property

The number of binary ones should differ binary zeros by at most one digit.

2) Run Property

A run is defined as a sequence of a single type of binary digits [2]. One half of the runs of zeros and one should be of length 1, one fourth should be of length 2 and so on.

3) Correlation property

The autocorrelation property of any two any two sequences from a set of PN codes is such that the number of agreements and disagreements should vary no more than one count.

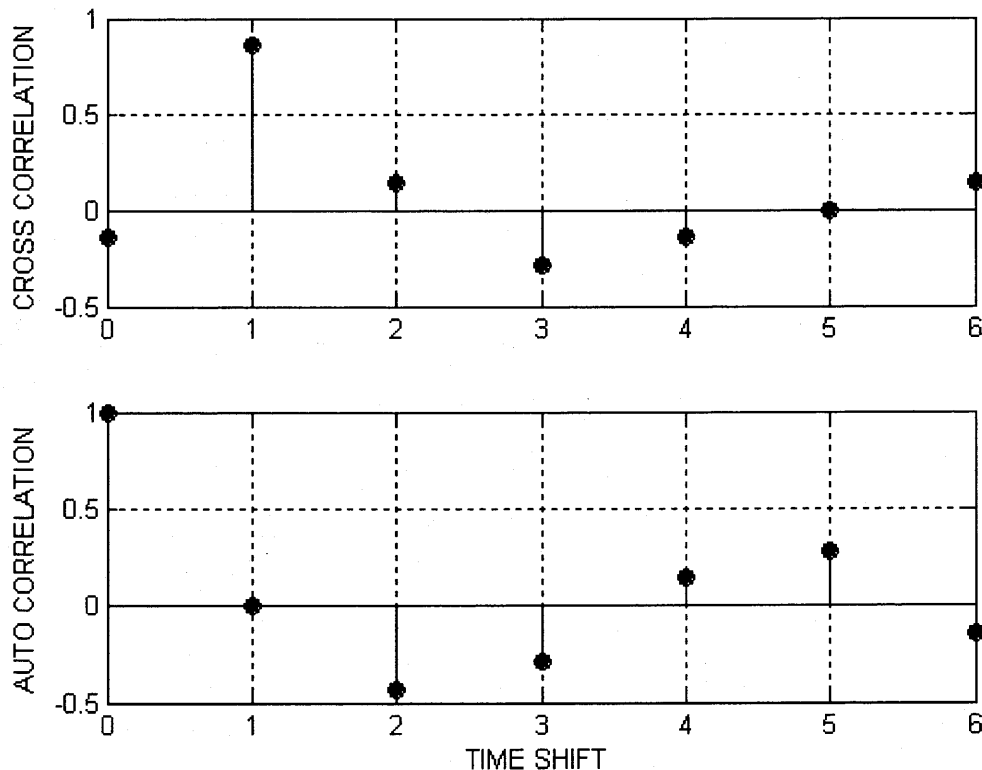

Figure 2.4 Auto Correlation and Cross Correlation properties of PN Codes.

2.3.2 PN Codes Generation

PN codes are generated using linear feedback shift register as mentioned in [2]. It is shown by taking a four stage shift register for storing and shifting and a modulo-2 adder and a feedback path from the adder to the input of the register. The contents of the feedback shift register are shifted on every clock pulse to the next stage. A modulo - 2 operation is performed on the shift register and is fed back to the first register.

2.4 Orthogonal Codes

These were the new codes proposed by the research student under Dr Ali Akansu. These codes were generated by searching the whole space of codes based on certain constraints.

2.4.1 Auto Correlation and Cross Correlation Properties

These codes exhibit better autocorrelation and cross correlation properties as compared to Walsh codes. As can be seen from the Figure below, the autocorrelation values die down at faster rates. Simulation results show that these codes perform well in asynchronous environment.

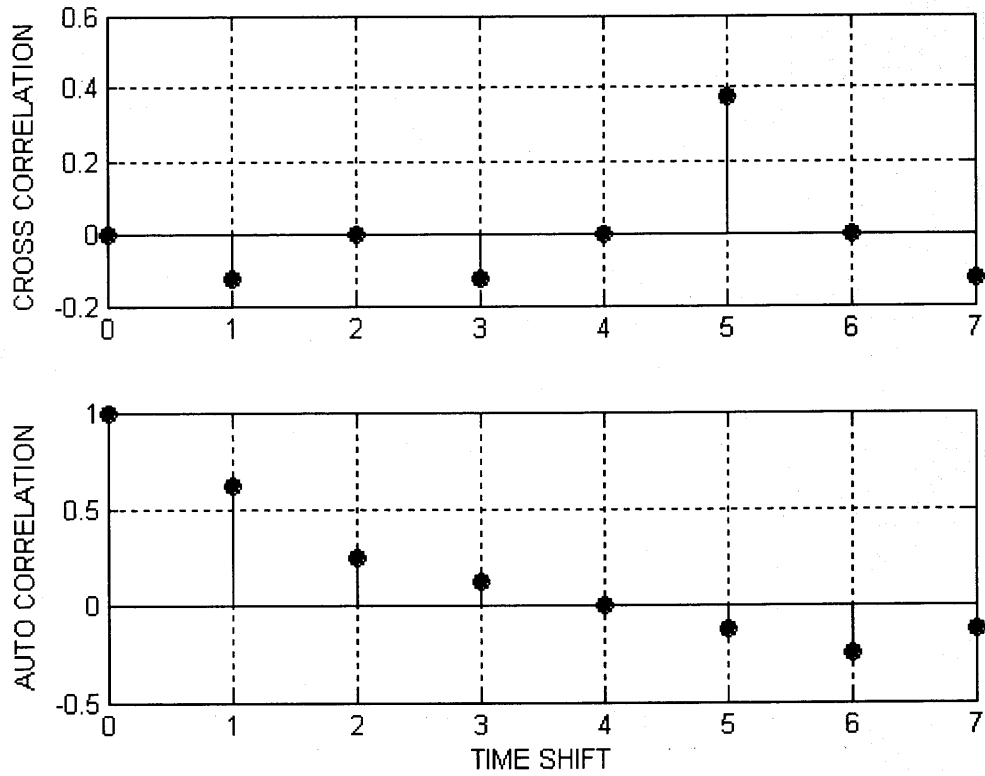

Figure 2.5 Auto Correlation and Cross Correlation properties of Orthogonal Codes.

CHAPTER 3

CHANNEL MODELS

The multi-path signal received at the antenna goes through different fading. These signals can be treated as coming from different channels. There are different channel models available in the literature based on empirical data as well as statistical properties. In this chapter a brief description of available channels models is discussed.

3.1 Small and Large Scale Fading Models

Small and large scale models are two broad categories that determine the change in signal strength over a distance as compared to the rapid fluctuation caused by the Doppler Effect and multi-path.

Large scale effect has been modeled in a number of ways. Most of the models are variants of Free Propagation Model. This model gives us a formula for finding out the received power of the signal in terms of distance (separation of transmitter and receiver).

The free propagation model is given by

$$P_r(d) = \frac{P_t G_t G_r \lambda^2}{(4\pi^2 d^2 L)}$$

Where $P_r(d)$ is the received power and is the function of transmitted power and is inversely proportional to square of the distance as mentioned in [1].

The drawback of Free Propagation model is that it does not take into account the reflection, scattering and is only based on the line of sight. The variants of propagation model like Ground Reflection (Two - Ray) model as mentioned in [1] takes into account the line of sight and reflected components. This model has been found to give reasonable

results for several kilometers [4]. Diffraction, scattering and refraction are not taken into account by these models. Many people have come up with different models to taken into the account these effects. Some of the models are based on empirical data such that Log-distance Path Loss Model and Log-normal shadowing model. Large scale fading model help us in determining the coverage area for a given base station.

3.2 Out Door Fading Models

Based on the empirical data, models have been created to fit the empirical data as closely as possible. For outdoor models, the presence of trees and buildings should be taken into effect. Some of these models mentioned in [1] are

- 1) Longley – Rice Model
- 2) Durkin's Model
- 3) Okumura Model
- 4) Hata Model
- 5) PCS Extension to Hata Model
- 6) Walfisch and Bertoni Model
- 7) Wideband PCS Microcell Model

3.3 Indoor Fading Models

There are a lot of factors that come into play when designing a wireless communication system for an indoor channel. Rappaport [1] Points out two aspects which are different than the traditional model. These are

- 1) distances covered are much smaller
- 2) Variability of the environment is much greater for a smaller range.

Factors like type of material such that concrete, partition, number of floors, material type play an important role in determining the attenuation of the reflected signal

and hence the fading the multi-paths go through before reaching the receiver.

Models mentioned in [1] for indoor fading models are

- 1) Log-distance Path Loss Model
- 2) Ericsson Multiple Breakpoint Model.

3.4 Type of Small Scale Fading Models

Small scale model takes into account the effect of multi-path and speed of the mobile.

Based on the signal bandwidth and the channel response, the signal goes through different types of fading. When multipath is taken into consideration, fading can be divided into two subcategories as mentioned in [1], namely

1) Flat fading

This type of fading occurs when the bandwidth of the fading channel is larger than the bandwidth of the signal. Under such fading, the spectral characteristics of the received signals are preserved.

2) Frequency selective fading

This type of fading occurs when the bandwidth of the signal is less than the bandwidth of the fading channel. Received signal in this case has got multiple versions of the same signal.

Based on Doppler spread, fading can be divided into the following two categories

1) Fast fading

This type of fading occurs if the rate of change of impulse response is faster as compared to the transmitted signal.

2) Slow fading

Channel response changes at a much smaller rate as compared to the transmitted signal.

3.5 Fading Models Based on Statistical Analysis

Fading channels have been modeled based on statistical analysis. There are a lot of available fading models which talks about the fading from the statistical point of view.

Some of these models are listed

- 1) Rayleigh fading model
- 2) Ricean fading model
- 3) Nakagami – m fading model
- 4) Nakagami – q fading model
- 5) Weibull fading
- 6) Clarke model
- 7) Jakes model

Rayleigh fading distribution is commonly used in wireless communication to describe the statistical time varying nature of the received envelope of a flat fading model [1]. Ricean distribution takes into care the line of sight component. In urban areas there is no direct line of sight component and Rayleigh model is used in that case. Nakagami – m is based on the fading severity [5]. M denotes the fading severity. Nakagami-q models fading signal amplitudes in satellite links that are subject to strong ionospheric scintillation [5]. Wiebull model has not been used as much as others. It provides statistical analysis of data obtained by narrow band path loss. It reduces to Rayleigh distribution when fading index m is equal to one [5]. Clarke [7] took into account the scattering effects of the electromagnetic waves and developed a statistical model. The model is based on assumption of a fixed transmitter with a vertically polarized antenna. It is a popular model and used a lot as a standard. Jakes model is a simplified version of Clarke model.

3.6 Clark Model

An implementation of Clark Model was carried out to simulate a wireless channel. A step by step procedure has been explained in detail in [1]. Clarke's model takes into account the Doppler spread of the moving object. However, it does not take into account the multi-path effects. In order to use multipath model with Clarke's model, a Rayleigh fading simulator is used. Shown below is a Rayleigh fading simulator, which takes into account different paths, with different attenuation and delays.

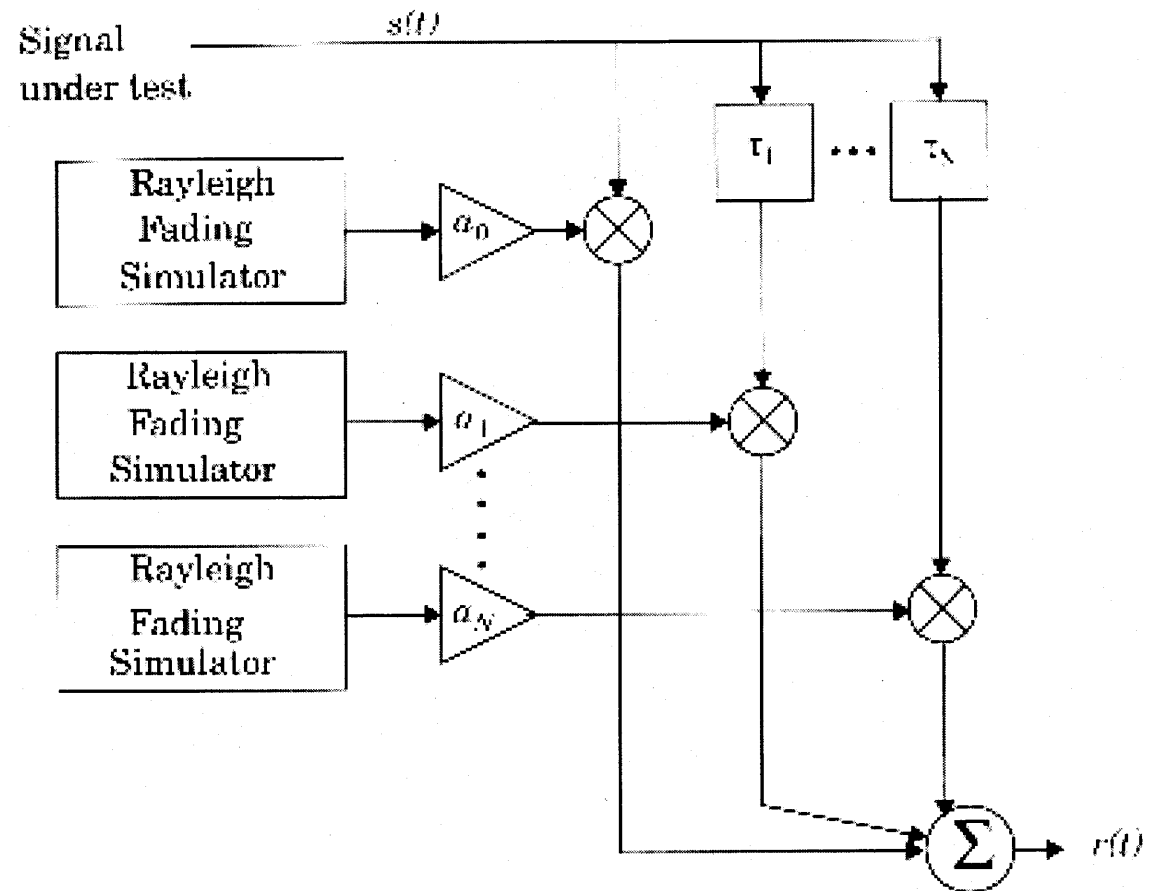

Figure 3.1 Rayleigh fading simulator.

Source: Rappaport [1]

It can be seen from the figure, that an incoming signal goes through different

delays. These delays are multiplied with different noise sources. In the implementation, Rayleigh block can be replaced by any given distribution of noise source. The noise amplitude is controlled by an attenuation factor. The signal is multiplied with a noise source. Different signals coming from different paths and going through different fading combine together and sum up at the receiver. In this case $s(t)$ is the signal under test and $r(t)$ is the received signal.

Effects of Doppler spread are incorporated using the Clarke's model which is shown in Figure 3.2.

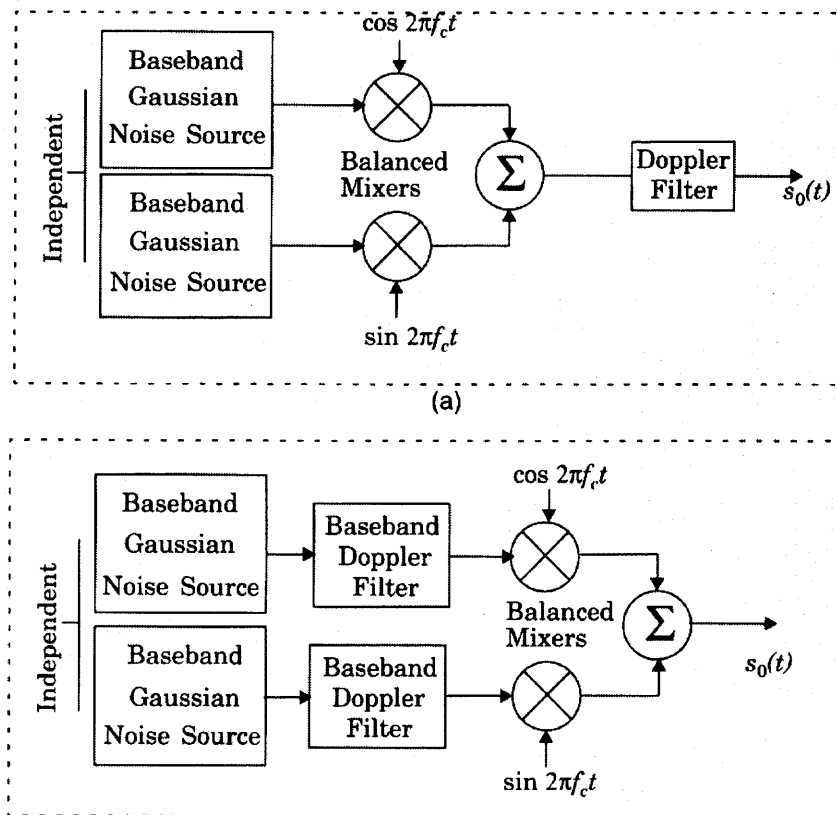

Figure 3.2 Simulator using quadrature amplitude modulation with a) RF Doppler filter b) baseband Doppler filter.

Source: Rappaport [1]

As shown in the figure above, two independent noise sources are generated and

modulated by an in phase and out phase component. These noise sources are then added and passed through a Doppler filter. Smith [8] used the following methodology to do the create the same scenario.

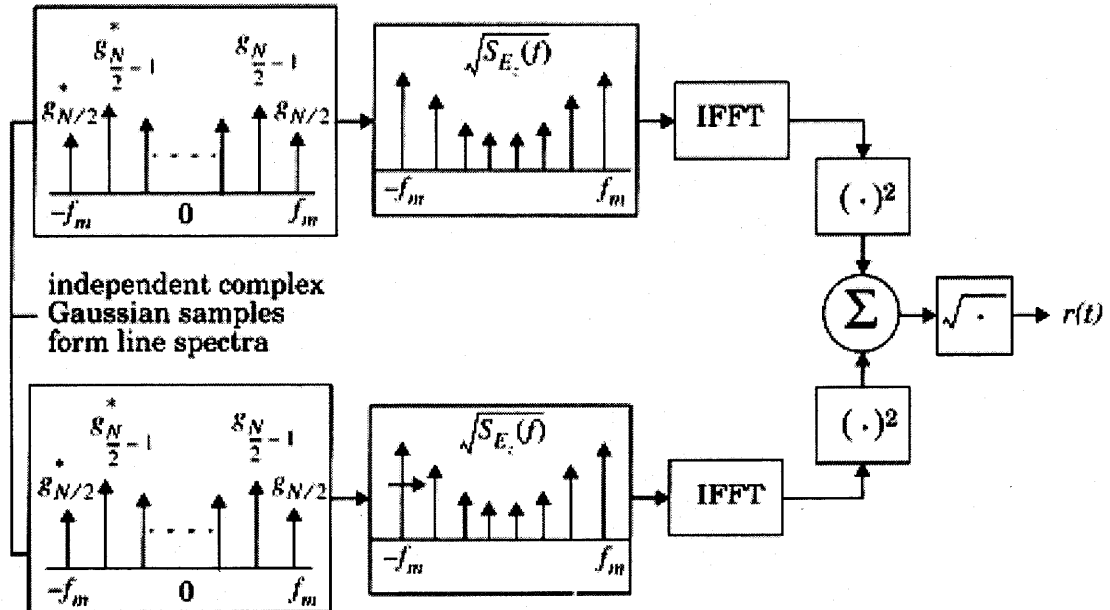

Figure 3.3 Frequency domain implementation of a Rayleigh fading simulator at baseband.

Source: Rappaport [1]

Two independent random noise sequences are generated. These sequences are treated to be in frequency domain. There are N frequency domain points. The output spectrum of this random noise is calculated. Square roots of IFFT of the power spectrum square from the two sources are summed together. The signal is then passed through a Doppler filter.

CHAPTER 4

PERFORMANCE OF MULTI-USER CODES IN FADING MODELS

Different tests were performed using the Clark model and the Rayleigh fading simulator. Gold, Walsh and orthogonal codes were tested using Asynchronous communication model. Their performance was compared based on the Code Length, number of users, different noise generators and number of multi-paths arriving at the receiver.

4.1 Effect of Code Length

Performance of different length Gold, Walsh and Orthogonal codes are discussed in this section. Synchronous and asynchronous communication scenarios were taken into account with these tests. Tests were performed with the following parameters fixed

- 1) 2 user codes
- 2) Channel: AWGN
- 3) Synchronous and Asynchronous communication

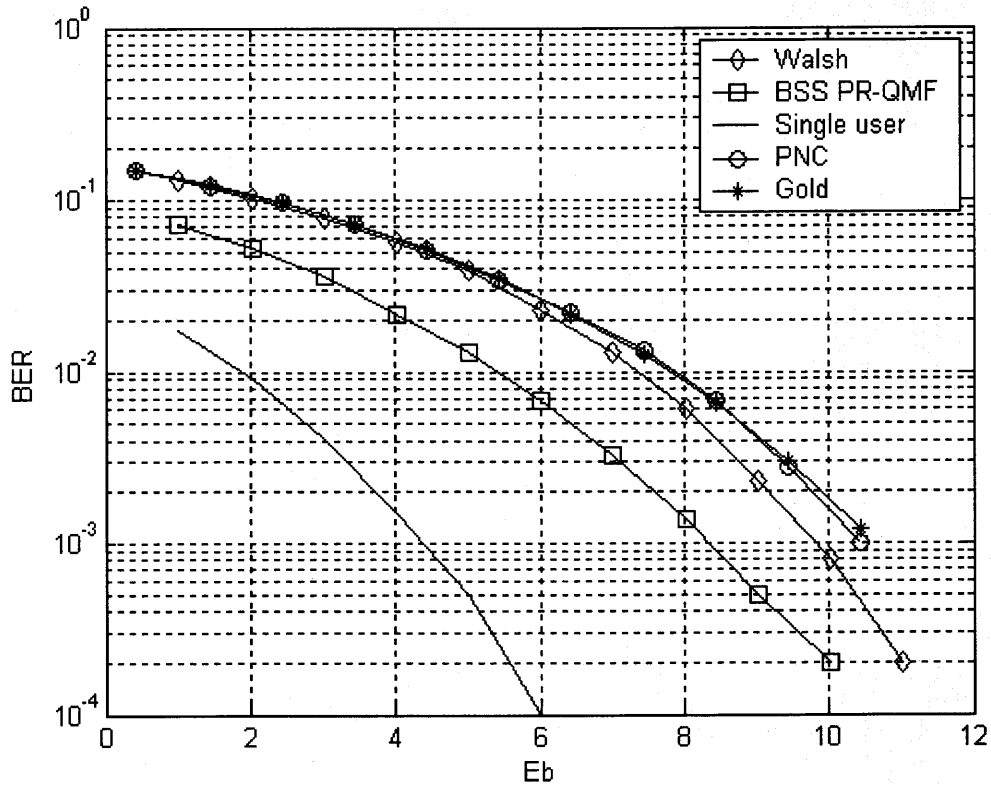

Figure 4.1 Synchronous fading results for 7 bit Gold and orthogonal codes and 8 bit Walsh, PN codes under AWGN.

Source : Radha[6]

The above scenario just takes into account synchronous communication. No delay between the codes is taken into consideration. A similar test was performed with random delays. Figure below shows the BER for different signal to noise ratio. It can be seen from the figure that orthogonal codes outperform other codes.

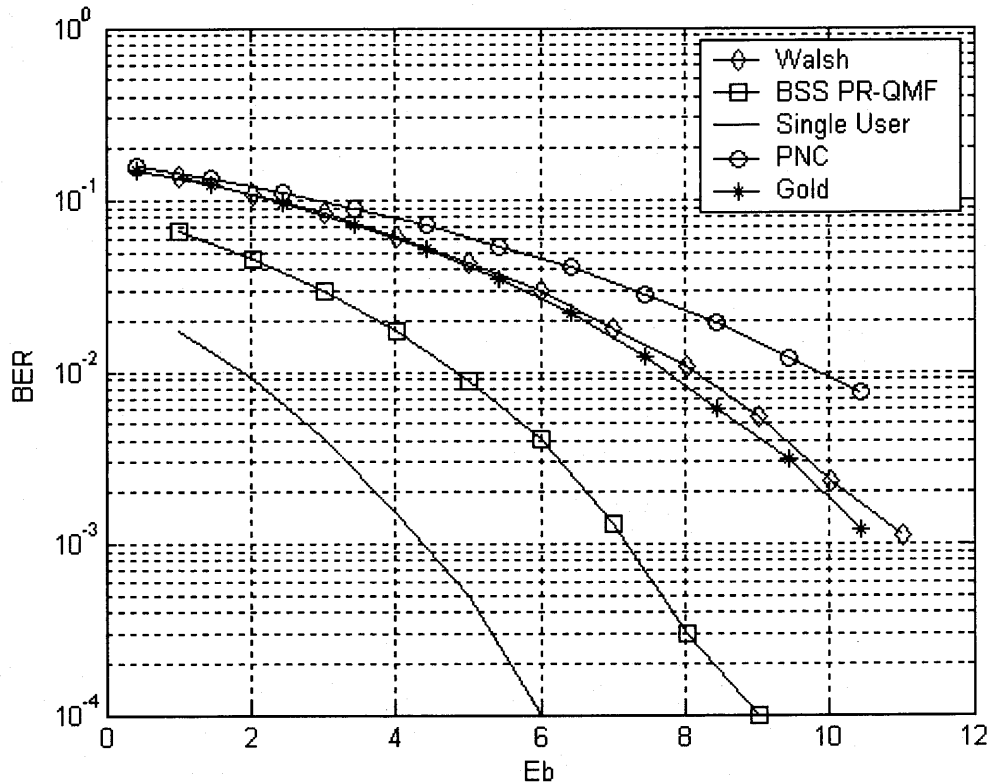

Figure 4.2 Synchronous fading results for 7 bit Gold and orthogonal codes and 8 bit Walsh, PN codes under AWGN.

Source: Radha [6]

The above tests were performed by taking any two user codes and checking their properties. However, to take into account the effect of all codes and come up with an average performance, testing methodology was changed. Tests were carried out for every pair of user codes and each code results were carried for more than 50 iterations so as to average out the random factor. The tests performed for 7 bit Gold codes, 7 bit orthogonal codes and 8 bit Walsh codes with two user scenario showed that the Gold codes perform very close to Gold codes.

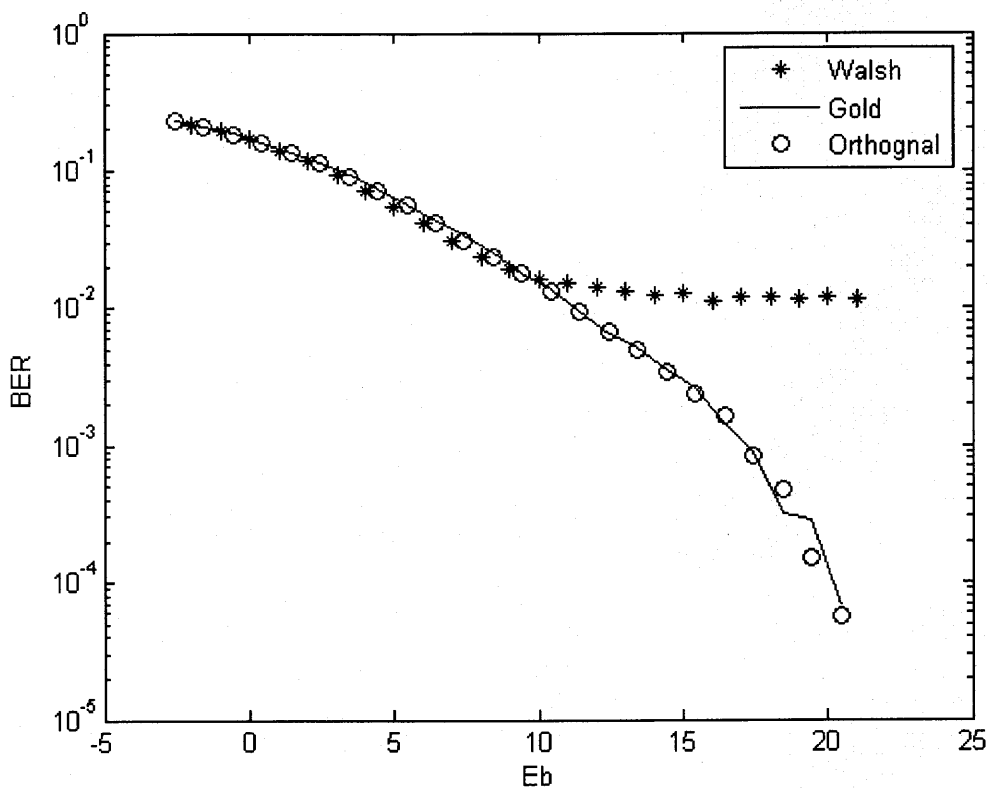

Figure 4.3 Asynchronous 7 bit Gold, 7 bit Walsh, 8 bit Orthogonal under AWGN.

The number of bits for the user codes was increased and the same test was performed for 16 bit Walsh and orthogonal codes. Gold codes with preferred product codes are not available for 16 bit. Figure 4.3 show that Walsh codes perform poorly in asynchronous communication. Orthogonal codes give much better results

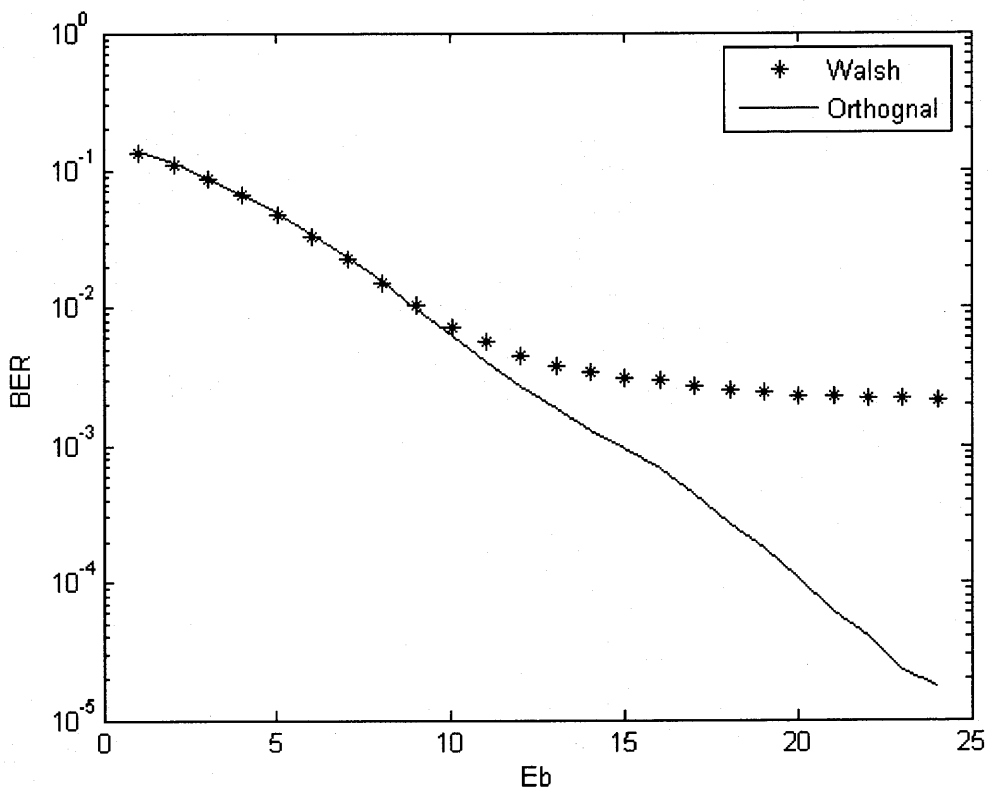

Figure 4.4 Asynchronous, 16 bit Walsh, 16 bit orthogonal codes under AWGN.

To compare the results with Gold codes having preferred product codes, 31 bit orthogonal codes were generated. These codes were tested against 32 bit Walsh and 31 bit Gold codes. Figure 4.5 show that orthogonal codes perform better than Walsh and very close to the Gold codes.

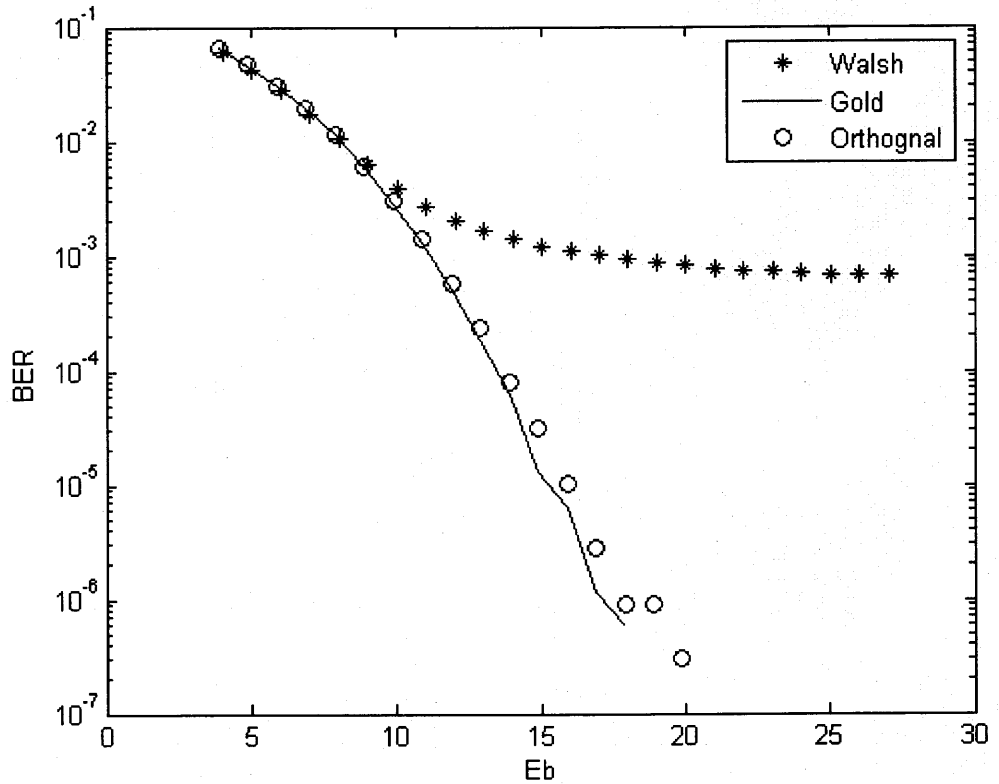

Figure 4.5 Asynchronous, 31 bit Gold, 31 bit Orthogonal, 32 bit Walsh under AWGN.

4.2 Effect of Multi-Users

This section changes the fixed parameter, number of users, and compares the effect of more than two users. This number was increased to 4. These tests were performed with the following fixed parameters

- 1) Channel: AWGN
- 2) Asynchronous communication
- 3) 7-bit Orthogonal and 16-bit orthogonal codes.

Results obtained from these tests support that orthogonal codes performance is better when there are more than one user.

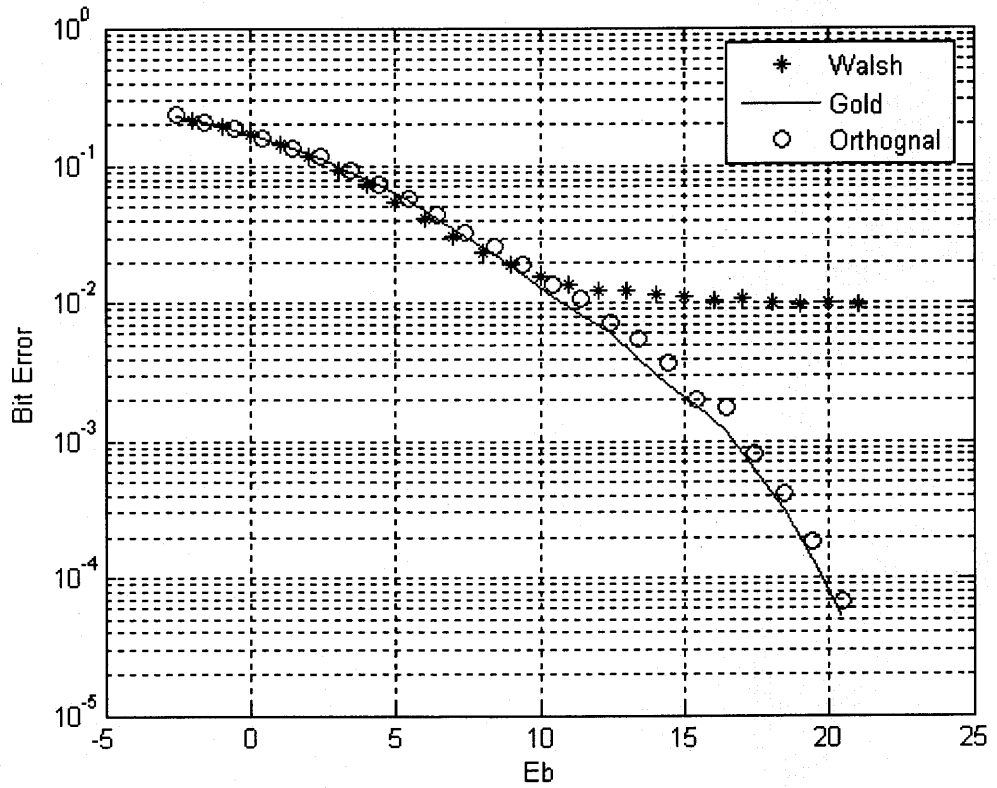

Figure 4.6 Asynchronous 7 bit Gold, 7 bit Orthogonal, 8 bit Walsh, 4 users.

The tests performed on 16 bit codes with four users using AWGN channel gave the following results

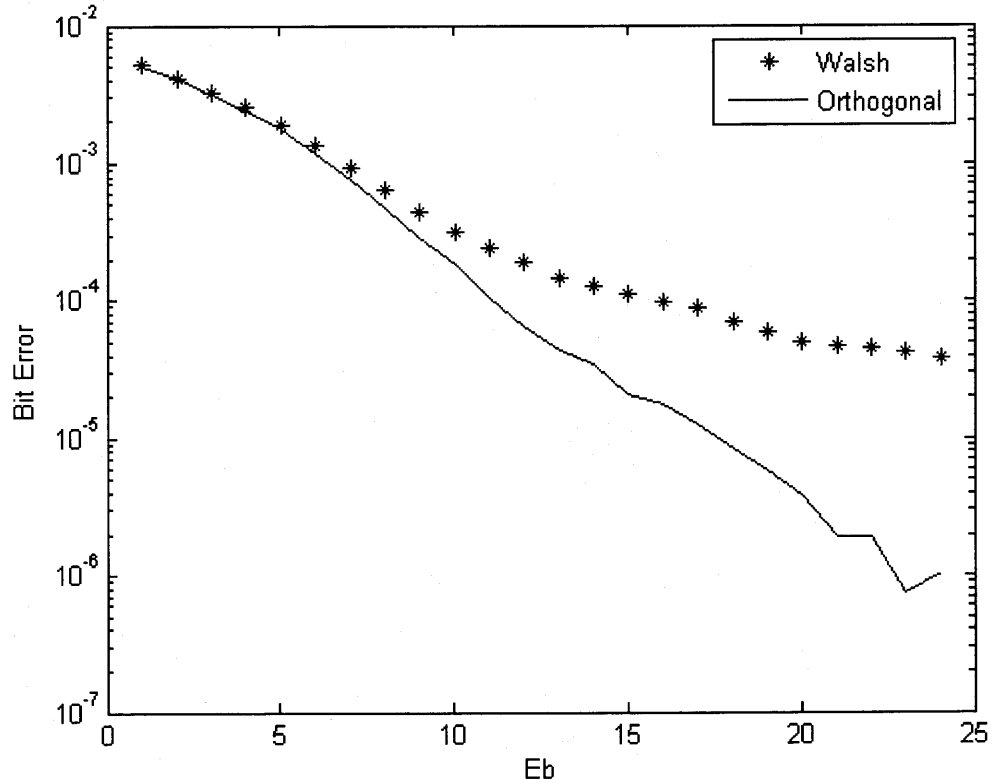

Figure 4.7 Asynchronous 16bit codes 4 users under AWGN.

Comparison of Figure 4.7 and 4.5 illustrates the decrease in performance of orthogonal codes. The results are still better than Walsh codes but the overall performance is decreased.

Gold codes with 31 bit length were compared in four user environment under AWGN. This test was performed by taking the first 50 combinations of each of the three codes. These tests do not take into consideration performance of all the different combinations. A uniform random variable was used to generate any 50 combinations. Walsh, Gold and Orthogonal codes were compared on these 50 different combinations. Each combination was tested for 100 iterations. Results in Figure 4.8 shows Orthogonal

and Gold codes performing well as compared to Orthogonal codes.

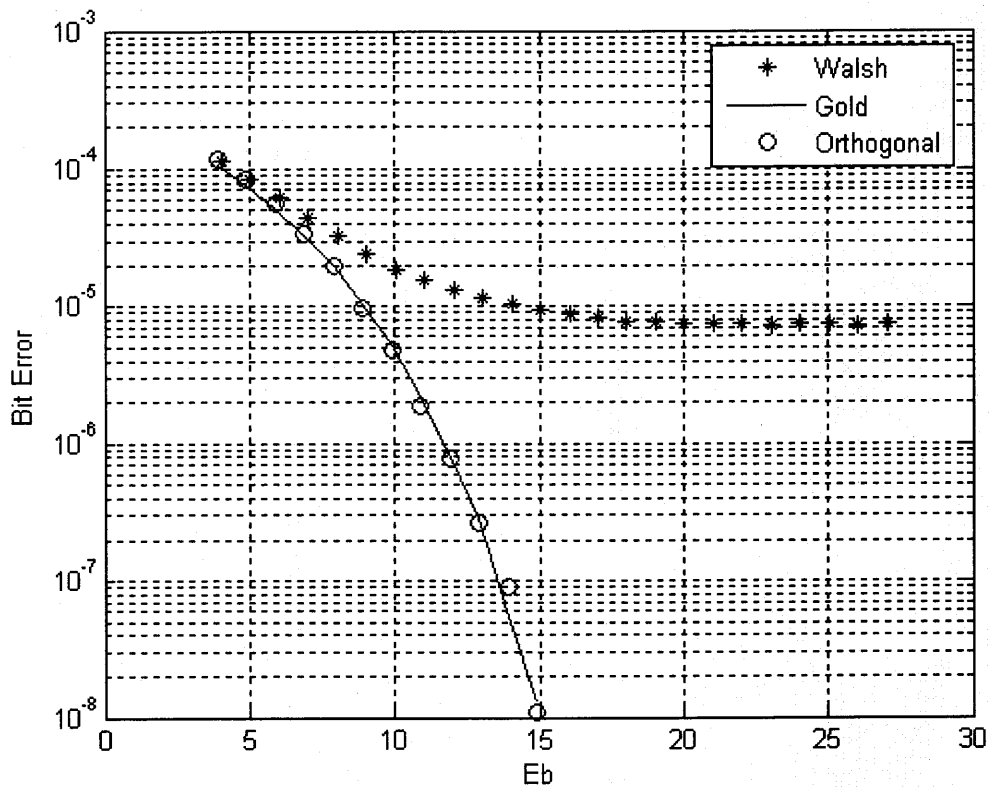

Figure 4.8 Asynchronous 31 bit Orthogonal codes with 4 users.

4.3 Effect of Different Noise generators

It was found in the tests that different noise generators effect the performance of the user codes dramatically. These results showed that Walsh performed better for low SNR, but its performance flattened with time. 7-bit user codes under AWGN performed very well and the result is shown in Figure 4.3. However, under Rayleigh fading model, the performance of Gold and Orthogonal codes go down. Noise was generated using the built in functions of Matlab, namely raylrnd. Noise was generated in the same range as AWGN. For 7-bit Orthogonal codes, the following results were obtained,

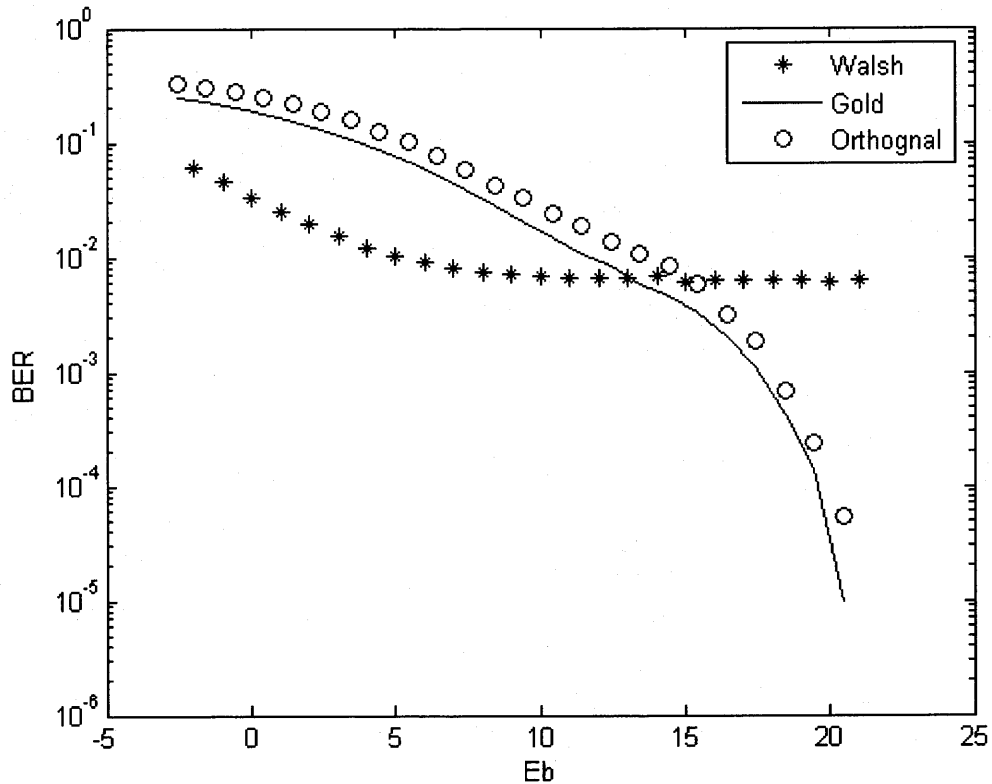

Figure 4.9 Asynchronous, 7 bit Orthogonal under Rayleigh noise.

It can be seen that at high SNR, Orthogonal codes perform better than Walsh. Walsh codes performance become flat with the increase of SNR whereas orthogonal codes tend to show a dramatic improvement.

4.4 Effect of Multipath

The multipath model used for this simulation is a Rayleigh fading simulator. It is shown in Figure 3.2. Different noise generators are used to produce noise. Signal under test is the transmitted signal with different delays. It is multiplied with different attenuations and summed together to get a multipath signal at the receiver.

To take into account the Doppler Effect introduced by the motion of the mobile, Clarke's model was used. Clarke's model generates Rayleigh noise generator taking into

account the speed of the mobile. The noise generator was built keeping in mind the Smith method as mentioned in Section 3.3, Figure 3.3. Two Gaussian random noise sources are generated. One is for the real part of the noise and the other is for imaginary part of the noise. Monte Carlo simulation methodology was used to generate these noise sources. It is compared with the actual Rayleigh PDF below,

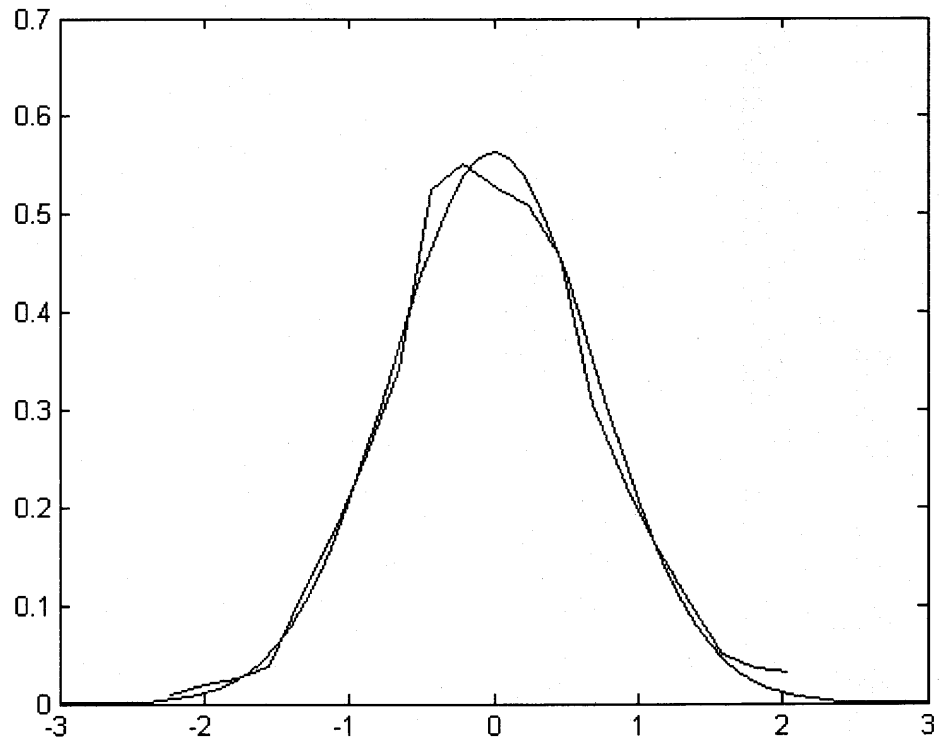

Figure 4.10 Real part of Gaussian noise for Clarke model.

The imaginary part of the Clarke model is shown in the figure below

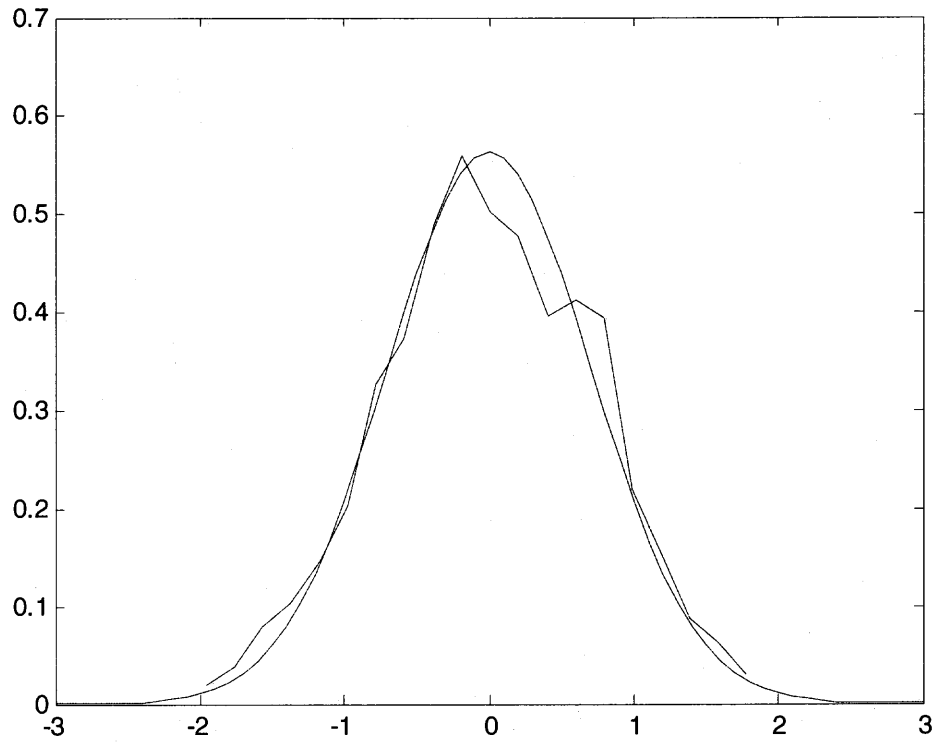

Figure 4.11 Imaginary part of Gaussian noise.

The enveloped for the signal after passing through the Doppler spectrum is shown in the Figure 4.12

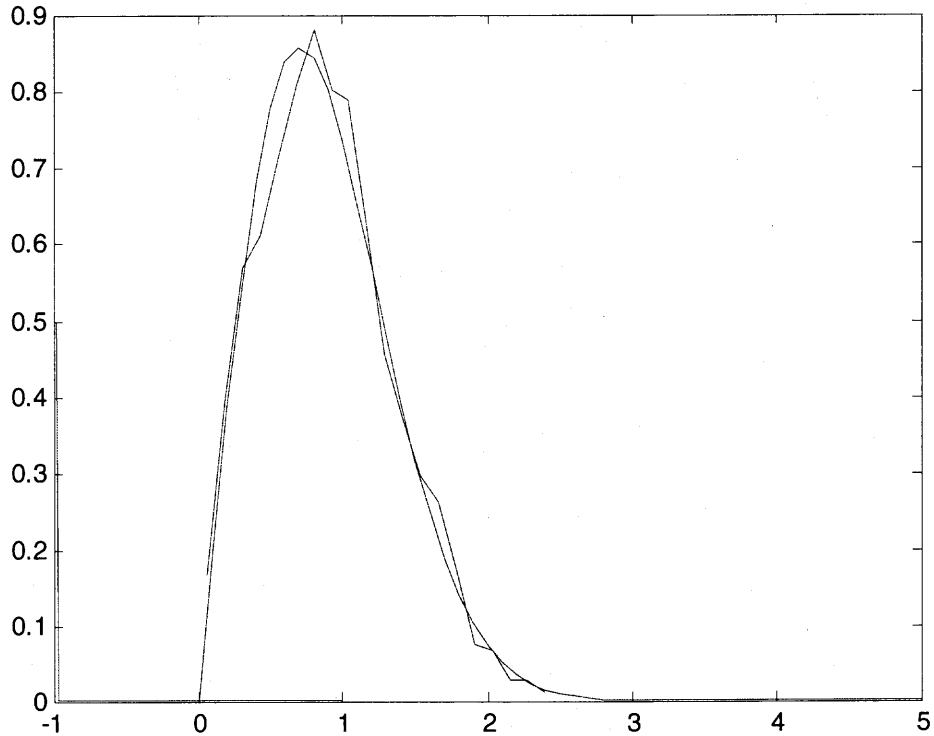

Figure 4.12 Histogram of the envelope as compared to the rayleigh distribution.

Using the Clarke model show in Figure 3.1, two delayed versions of the transmitted signal was passed through two AWGN channels with equal attenuation. The sum of the two received signal was passed to the detector. This test was performed for a two user code and is show in Figure 4.13. Results show that orthogonal codes perform better than both Gold and Walsh codes.

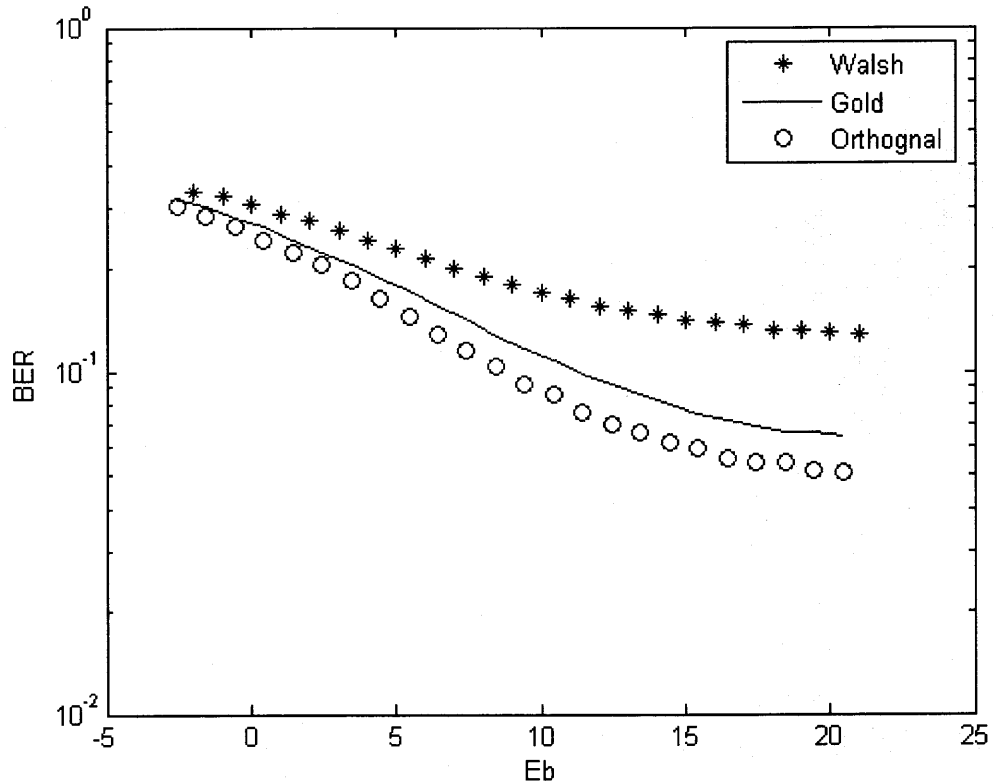

Figure 4.13 Two users with two multi-paths in AWGN.

AWGN block was replaced with Rayleigh noise generator in the Rayleigh fading simulator shown in figure 3.1. As discussed in Section 4.3, Orthogonal and Gold codes performance is very close to Walsh at low SNR. However at high SNR, there is a significant improvement in the Orthogonal codes.

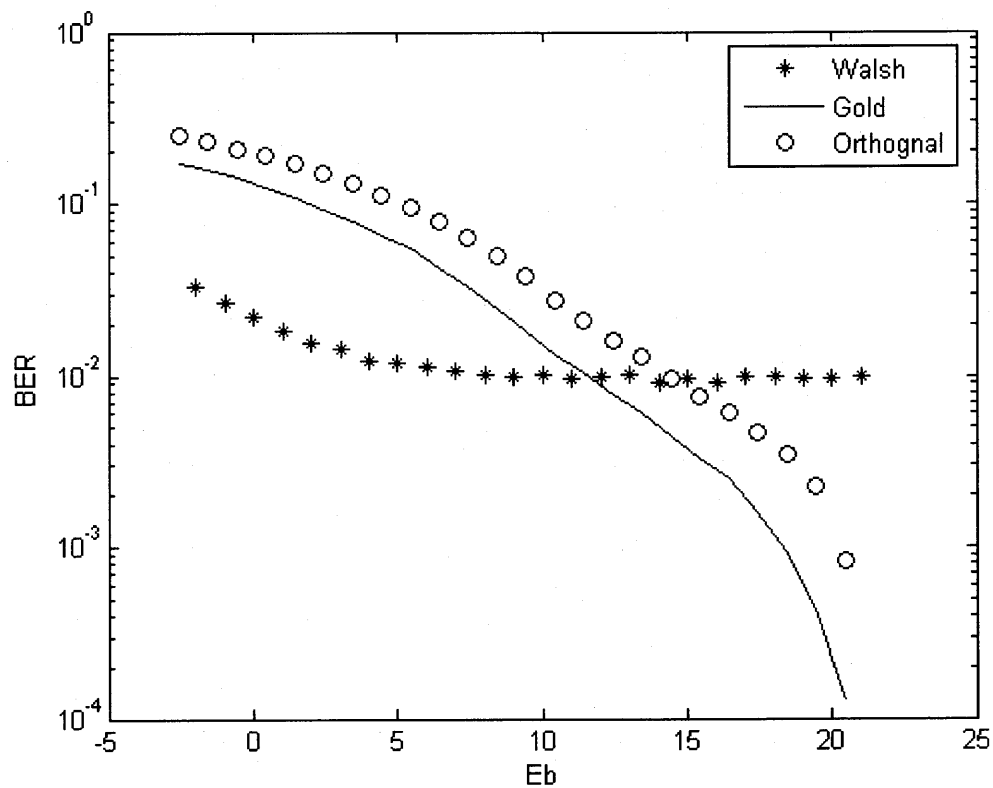

Figure 4.14 Two users with two multi-paths in Rayleigh.

With four user in considerations and 4 multi-paths, tests reveal that Orthogonal codes perform better than Gold and Walsh codes. This test was carried out under AWGN with four multi-paths. The results are shown in the figure 4.15

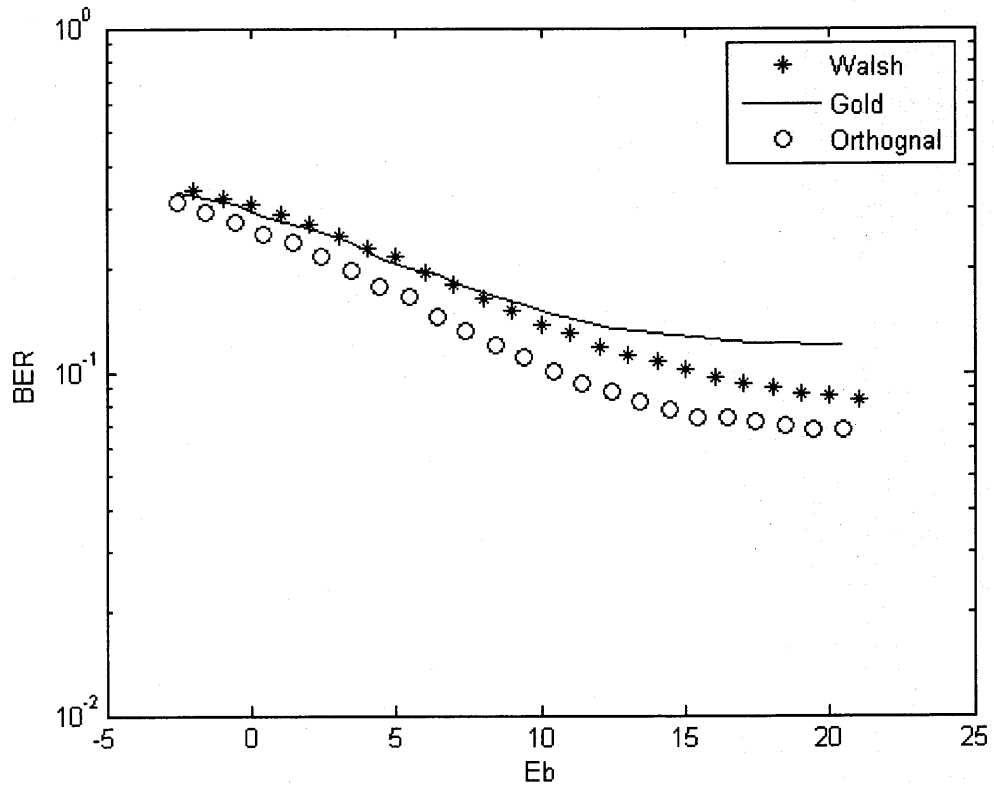

Figure 4.15 Four users with four multi-paths in AWGN.

CHAPTER 5

CONCLUSION AND FUTURE WORK

In chapter 4, a comparison of the performance of codes under different channels with different number of users and multi-paths was carried out. Results show that the new orthogonal codes possess some good autocorrelation properties. These properties make the orthogonal code perform very close to the Gold codes.

The development of new orthogonal codes is still in progress. There are some very positive results with the new orthogonal codes and expect to outperform Gold codes in future. The simulator used for modeling wireless channel takes into account a certain number of multi-paths taking into account the effects of multipath and Doppler shift. This model can be enhanced by taking into consideration the effects of scattering, diffraction. The tests carried out were computationally very intensive and were taking a lot of iterations to complete. In order to move to 64 and higher bit user codes and take into consideration multi-paths, a hardware implementation of the channel is required.

APPENDIX

MATLAB PROGRAM

In this appendix the matlab code for the simulator is included

```
% This simulation tests performance of different user codes under different  
% channels
```

```
clear
```

```
%-----Configurauration-----%
```

```
%Testing for two paths.
```

```
disp('Settings');
```

```
dataSize = 100 %length of signal
```

```
%NOTE: Each element of the array corresponds to the respective clark model
```

```
%path with appropriate setting. See diagram in Rappaport book
```

```
%code attributes
```

```
codeType = 1; %PN 1, Walsh 2, Gold 3, BSS 4
```

```
%color setting for plots
```

```
sColor = [ 'r' ]
```

```
    %r for Walsh codes
```

```
    %b for new Orthogonal codes
```

```
%channel attributes
```

```
channelType = [0 0]; %awgn 0 , rayleigh 1, rician 2
```

```
attenuation = [1 1]; %NOTE: Attenuation should never be zero
```

```
delay = [0 0]; %delay in the first and second multipath
```

```

%delayUpLink = [0 1];

%Modified: 3/13/05
SNR = [-8:1:15];
mcnt = 50;

%-----Transmitter-----%
combinations = combnk(2:16, 2);
AvgBER = zeros(1, length(SNR));
for j = [1: length(sColor)]

    if(j ==1)

        codeType = 7;
    else

        codeType = 8;
    end

    BER_ALLSNR_Delay_Avg = zeros(1, length(SNR));;
    for m = 1 : length(combinations)
        %For every combination, test is performed 10 times with different delays
        %[testCodeUser1 testCodeUser2] = userCode(codeType);
        m
        randomDelay = randint(1,mcnt,16);
        [testCodeUser1      testCodeUser2]      =      userCode2(codeType,
combinations(m,1),combinations(m,2));
    %-----end-----%

```

REFERENCES

- [1] Rappaport, S. Theodore (2001), “Wireless Communications, Principles and Practice”, (Second Edition), Prentice Hall publishers.
- [2] Bernard, Sklar, “Digital Communication: Fundamentals and Applications”, (second edition), Prentice Hall, 2001.
- [3] Matlab Reference, “Matlab Online help – www.mathworks.com”. Access on January 4, 2005
- [4] Feuerstein, M.J., Blackard, K.L., Rappaport, T.s., Seidel, S.Y., and Xia, H.H., “Path Loss, Delay Spread, and Outage Models as Functions of Antenna Height for Microcellular System Design”, IEEE Transactions on Vehicular Technology, vol. 43, no. 3, pp. 478-498, August 1994.
- [5] Chengshan, Xiao and Yahong, R. Zheng, “A Statistical Simulation Model for Mobile Radio Fading Channels”, in Proc. IEEE ICC, pp. 709-716, April 2002.
- [6] Palouri, Radha, Akansu, Ali N, “New Orthogonal Binary Codes For Multiuser spread spectrum communications.
- [7] Clarke, R.H., “A Statistical Theory of Mobile-Radio Reception”, Bell Systems Technical Journal, vol. 47, pp. 957-1000, 1968.