

Copyright Warning & Restrictions

The copyright law of the United States (Title 17, United States Code) governs the making of photocopies or other reproductions of copyrighted material.

Under certain conditions specified in the law, libraries and archives are authorized to furnish a photocopy or other reproduction. One of these specified conditions is that the photocopy or reproduction is not to be “used for any purpose other than private study, scholarship, or research.” If a user makes a request for, or later uses, a photocopy or reproduction for purposes in excess of “fair use” that user may be liable for copyright infringement,

This institution reserves the right to refuse to accept a copying order if, in its judgment, fulfillment of the order would involve violation of copyright law.

Please Note: The author retains the copyright while the New Jersey Institute of Technology reserves the right to distribute this thesis or dissertation

Printing note: If you do not wish to print this page, then select “Pages from: first page # to: last page #” on the print dialog screen



The Van Houten library has removed some of the personal information and all signatures from the approval page and biographical sketches of theses and dissertations in order to protect the identity of NJIT graduates and faculty.

ABSTRACT

LABVIEW CONTROLLED STUDY OF THE PROPAGATION PROPERTIES OF ULTRASOUND IN SYNTHETIC FOG ENVIRONMENT

**by
Aparna Venkataraman**

Diagnostic ultrasound employs pulsed, high frequency sound waves that are reflected back from body tissues and processed by ultrasound receivers to create characteristic images in varied applications such as cardiology, obstetrics and gynecology neurology and urology. Ultrasound intensity is primarily affected by the changes in acoustic impedance of the medium. Literature on ultrasound indicates that the propagation of ultrasound increases gradually as the density increases from air to water. Such studies have been confined to only the three states of matter and have never discussed a fog medium.

The primary objective of this thesis study was to design a system in order to control the ultrasound transceivers in an artificially created fog atmosphere. The ultimate objective of this study is to construct a complete “Fog Imaging System”, where a human subject can be completely scanned without the help of any conductive gel. The software controls the generation of “synthetic fog” atmosphere and the sequential triggering of ultrasound transducers. Reliability and accuracy of the data acquired was tested and verified. Densities versus intensity charts were drawn and the intensity of ultrasound was found to decrease with increasing densities of fog.

**LABVIEW CONTROLLED STUDY OF THE PROPAGATION
PROPERTIES OF ULTRASOUND IN SYNTHETIC FOG ENVIRONMENT**

**by
Aparna Venkataraman**

**A Thesis
Submitted to the Faculty of
New Jersey Institute of Technology
in Partial Fulfillment of the Requirements for the Degree of
Master of Science in Biomedical Engineering**

Department of Biomedical Engineering

January 2005

APPROVAL PAGE

**LABVIEW CONTROLLED STUDY OF THE PROPAGATION PROPERTIES OF
ULTRASOUND IN SYNTHETIC FOG ENVIRONMENT**

Aparna Venkataraman

Dr. Tara Alvarez, Thesis Advisor Date
Assistant Professor of Biomedical Engineering
New Jersey Institute of Technology

Mr. Michael T. Bergen, Committee member Date
Biomedical Engineer
Veterans Affairs New Jersey Health Care System, East Orange
Adjunct Professor of Biomedical Engineering
New Jersey Institute of Technology

Dr. Richard J. Servatius, Committee member Date
Director of Veterans Affairs New Jersey Health Care System, East Orange
Assistant Professor of Neuroscience
New Jersey Medical School/University of Medicine and Dentistry of NJ

Dr. David Kristol, Committee member Date
Professor of Biomedical Engineering
New Jersey Institute of Technology

BIOGRAPHICAL SKETCH

Author: Aparna Venkataraman

Degree: Master of Science

Date: January 2005

Undergraduate and Graduate Education:

- Master of Science in Biomedical Engineering,
New Jersey Institute of Technology, Newark, NJ, 2002
- Bachelor of Science in Electrical Engineering,
University of Madras, Chennai, India, 1997

Mom, hope I did you proud.

ACKNOWLEDGEMENT

I would like to start by extending my heartfelt thanks to my thesis advisor, Dr. Tara Alvarez, for her constant input and feedback on my throughout the length of this study. She had been inspiring and encouraging during my period of work under her.

To Prof. Michael Bergen, for providing me with the kind of motivation and guidance that made me think through the study and seek knowledge as an outcome of it. His resourceful knowledge and patience were the keys to complete this research study.

I would like to express my deepest gratitude to Dr. Richard Servatius, for letting me work under him at the VA health care system, NJ while working towards my master's degree. I was able to hone my skills and knowledge in the field of Biomedical Research.

My sincerest appreciation goes to Dr. David Kristol, for his unconditional support in my career and my research work. It wouldn't have been possible otherwise for me to achieve what I have without his support.

To Prof. Scott Scoldan and Mr. Robert De Marco, for always being there to help the students, with the different kinds of problems we come up with. Their kind support has helped us seek solution to the problems and improve our projects.

Special thanks goes to Ms. Rupal Patel and Mr. Michael Ocasio for helping me with software and hardware development and making this research experience memorable.

TABLE OF CONTENTS

| Chapter | Page |
|--|-------------|
| 1 INTRODUCTION..... | 1 |
| 1.1 Objective..... | 1 |
| 1.2 Fundamentals of Ultrasound..... | 3 |
| 1.2.2 The Wave Equation..... | 4 |
| 1.2.3 Quantative Properties..... | 5 |
| 1.2.3.1 Time..... | 5 |
| 1.2.3.2 Space and Wavelength..... | 5 |
| 1.2.3.3 Magnitude..... | 5 |
| 1.2.4 Pulse Mode..... | 6 |
| 1.2.5 Generation of Ultrasound..... | 6 |
| 1.2.5.1 Beam Formation..... | 7 |
| 1.2.5.2 Noise..... | 8 |
| 1.2.6 Effects of Medium..... | 8 |
| 1.2.6.1 Attenuation..... | 9 |
| 1.2.6.2 Reflection..... | 9 |
| 1.2.7 Sound Propagation and Interaction with Target..... | 10 |
| 1.2.7.1 Refraction..... | 10 |
| 1.2.7.2 Scatter..... | 10 |
| 1.2.8 dB Notation..... | 10 |
| 1.2.9 Mechanisms of Reception..... | 11 |

TABLE OF CONTENTS
(Continued)

| Chapter | Page |
|---|-------------|
| 1.3 Introduction to Fog..... | 12 |
| 1.4 Background..... | 14 |
| 1.4.1 Ultrasound and Fog Medium..... | 15 |
| 1.4.2 Extinction Co-Efficient..... | 18 |
| 2 IMPLEMENTATION..... | 19 |
| 2.1 Materials and Methods..... | 19 |
| 2.1.1 System Description..... | 20 |
| 2.1.2 Software Selection..... | 22 |
| 2.2 Fog Control Software Development..... | 24 |
| 2.2.1 Arming and Triggering..... | 24 |
| 2.3 Ultrasound Generation and Acquisition..... | 26 |
| 2.3.1 Conditional Retrieval..... | 27 |
| 2.4 Fog Generation and Timing control..... | 29 |
| 2.4.1 Panel Input/Output Board..... | 30 |
| 2.4.1.1 Control Outputs..... | 30 |
| 2.4.1.2 Control Inputs..... | 31 |
| 2.4.1.3 Keyboard Control..... | 31 |
| 2.4.2 Fog Activation Duration..... | 32 |
| 2.5 Ultrasound Hardware Selection and Evaluation..... | 33 |
| 2.6 Transducers Description..... | 34 |
| 2.6.1 Maximum Sensitivity..... | 37 |

TABLE OF CONTENTS
(Continued)

| Chapter | Page |
|--|-------------|
| 2.6.2 Temperature and Humidity..... | 37 |
| 2.6.3 Interference (Electrical and Acoustical)..... | 38 |
| 2.6.4 Target Strength..... | 38 |
| 2.6.5 Beam Angle..... | 38 |
| 2.6.6 Minimum Sensing Range..... | 39 |
| 2.6.7 Mounting..... | 39 |
| 3.7 Switching interface..... | 40 |
| 3 SAFETY..... | 42 |
| 3.1 Introduction. | 42 |
| 3.2 Fog and Safety..... | 42 |
| 3.3 The Characteristics of Glycol Based Theatrical Fogs..... | 43 |
| 3.4 Previous Research About Theatrical Fogs..... | 44 |
| 3.4.1 NIOSH Health Hazard Evaluation..... | 44 |
| 3.4.2 Consultech Engineering Study..... | 44 |
| 3.4.3 Mount Sinai and Environ Study..... | 45 |
| 3.4.3.1 Chemical Analysis | 45 |
| 3.4.3.2 Exposure Levels | 45 |
| 3.4.3.3 Health Effects..... | 46 |
| 3.5 Glycol Thermal Degradation Products. | 47 |
| 3.5.1 Dissipation Speed and Density..... | 47 |
| 3.5.2 Physical Density or Weight..... | 47 |
| 3.6 Relevant Exposure Limits..... | 49 |

TABLE OF CONTENTS
(Continued)

| Chapter | Page |
|---|-------------|
| 3.6.2 Short Term Exposure Limits..... | 49 |
| 3.6.3 Ceiling Limit..... | 49 |
| 3.7 Conclusions on Fog Safety..... | 50 |
| 3.8 Introduction to Ultrasound Safety..... | 51 |
| 3.8.1 Thermal Effects..... | 51 |
| 3.8.2 Mechanical Effects..... | 52 |
| 3.8.3 Cavitation..... | 52 |
| 3.9 The AIUM's Statement..... | 53 |
| 3.10 Summary of Epidemiological Evidence..... | 53 |
| 3.11 Conclusions on Ultrasound Safety..... | 54 |
| 4 SYSTEM OPERATION AND TESTING..... | 55 |
| 4.1 Introduction..... | 55 |
| 4.2 Ultrasound Propagation and Reflection Properties..... | 55 |
| 4.3 Testing..... | 56 |
| 4.3.1 Testing of Transducers..... | 56 |
| 4.3.2 Testing of Driving Circuitry..... | 59 |
| 4.4 Materials and Methods..... | 60 |
| 4.4.1 Fog Chamber..... | 60 |
| 4.4.2 Vents..... | 61 |
| 4.4.3 Target and Position of Target..... | 61 |
| 4.4.4 Position of Synthetic Fog Machine..... | 62 |

TABLE OF CONTENTS
(Continued)

| Chapter | Page |
|---|-------------|
| 4.4.5 Transducers..... | 62 |
| 4.4.6 Synthetic Fog Machine..... | 62 |
| 4.4.7 Software and Hardware System..... | 63 |
| 4.5 Data Collection and Analysis..... | 63 |
| 4.5.1 Protocol for Data Acquisition..... | 63 |
| 4.5.2 Data Acquisition..... | 64 |
| 4.5.3 Sampling Rate..... | 64 |
| 4.5.4 Sampling Frequency..... | 65 |
| 4.5.5 Temperature..... | 65 |
| 4.5.6 Software System..... | 66 |
| 4.5.7 Hardware System..... | 67 |
| 4.6 Results..... | 68 |
| 4.7 Conclusion..... | 70 |
| 5 CONCLUSIONS..... | 71 |
| 5.1 Introduction..... | 71 |
| 5.2 Design and Implementation..... | 71 |
| 5.3 Software and Hardware Considerations..... | 72 |
| 5.3.1 Software System..... | 73 |
| 5.3.2 Hardware System..... | 73 |
| 5.4 Future Improvements..... | 74 |
| 5.4.1 Improvement in Research Area..... | 74 |
| 5.4.2 Software Development..... | 75 |

TABLE OF CONTENTS
(Continued)

| Chapter | Page |
|--|-------------|
| 5.4.3 Hardware Development..... | 76 |
| 5.5 Conclusion. | 77 |
| APPENDIX A Front Panel And Block Diagram Of Fog Control Program..... | 78 |
| APPENDIX B Block Diagram For Sequential Triggering Of Transducers..... | 82 |
| APPENDIX C Front Panel For Sequential Triggering Of Transducers..... | 83 |
| APPENDIX D Front Panel For Ultrasound Signal Processing..... | 84 |
| APPENDIX E Block Diagram For Ultrasound Signal Processing..... | 85 |
| APPENDIX F Voltage (Vs) Time Graphs For 30khz Transducer At 1ft..... | 86 |
| APPENDIX G Voltage (Vs) Time Graphs for 40KHZ Transducer at 1FT..... | 87 |
| REFERENCES..... | 91 |

LIST OF TABLES

| Table | | Page |
|--------------|--|-------------|
| 1.1 | Description of material properties..... | 16 |
| 3.1 | Types Of Health Effects Due To Glycols | 48 |
| 4.1 | Digital Inputs..... | 60 |

LIST OF FIGURES

| Figure | | Page |
|---------------|---|-------------|
| 2.1 | Block diagram of the overall experimental setup..... | 20 |
| 2.2 | Block diagram of the Fog Chamber..... | 21 |
| 2.3 | Block diagram of “Synthetic Fog” generator..... | 24 |
| 2.4 | Flow chart for software control of the “Synthetic Fog” generator..... | 25 |
| 2.5 | Block diagram explaining control and corresponding data acquisition.... | 26 |
| 2.6 | Picture of the eight transducers chosen for the study..... | 27 |
| 2.7 | Flow chart explaining the software control of the transducers..... | 28 |
| 2.8 | LED Indications on the fog generation system showing the different possible combinations in the display board of the synthetic “Synthetic Fog” generator..... | 29 |
| 2.9 | Panel Input/Output board..... | 32 |
| 2.10 | Excitation and reception signals | 35 |
| 2.11 | Encapsulation of Piezoceramic material. | 36 |
| 2.12 | Transducer Equivalent circuit..... | 36 |
| 2.13 | Signal attenuation as a function of temperature, frequency and air pressure..... | 37 |
| 2.14 | Influence of target material and target angle on the incident beam..... | 38 |
| 2.15 | Block Diagram explaining the operation of the switching interface..... | 39 |
| 2.16 | Block Diagram explaining the switching interface controlling one transducer..... | 40 |

LIST OF FIGURES

(Contd.)

| Figure | | Page |
|---------------|--|-------------|
| 4.1 | Magnified graph showing the number of data points Vs Voltage level of a 40 KHz transducer..... | 57 |
| 4.2 | Magnified graph showing the number of data points Vs Voltage level of a 40 KHz transducer..... | 58 |
| 4.3 | Graph showing the transmitted and received pulses plotted between the Voltage level of the transducers and the time taken..... | 66 |
| 4.4 | Voltage (Vs) Fog level for 30 KHz transducer at 1ft distance..... | 68 |
| 4.5 | Voltage (Vs) Fog level for 30 KHz transducer at 3ft distance..... | 68 |
| 4.6 | Voltage (Vs) Fog level for 40 KHz transducer at 1ft distance..... | 69 |
| 4.7 | Voltage (Vs) Fog level for 40 KHz transducer at 3ft distance..... | 69 |

CHAPTER 1

INTRODUCTION

1.1 Objective

The use of ultrasonic waves in the field of medicine started initially with its applications in therapy rather than in diagnosis, utilizing its heating and disruptive effects on animal tissues. The destructive ability of high intensity ultrasound had been recognized ever since the destruction of school of fishes in the sea was observed when a water tank was insonated with high intensity ultrasound. High intensity ultrasound progressively evolved to become a neuro-surgical tool. The primary limiting constraint in the use of ultrasound as a diagnostic tool is the propagation characteristics of ultrasound in the medium of its application.

Ultrasound waves travel through any medium with a velocity that is controlled by the medium itself. Elasticity and density of a medium are found to be the two basic physical properties that govern the velocity of sound waves through the medium. Therefore, though solids such as steel and glass are far denser than air, their elasticity is comparatively greater that the velocities of sound in them are fifteen times greater than the velocity of sound in air. Using elasticity as an indication of the speed of sound in a given medium, we can conclude that sound travels faster in harder materials, slower in liquids and slowest in gases.

Previous researches measuring the propagation properties of ultrasound in a fog medium are extremely limited. The goal of this thesis study is to design and develop the necessary hardware and software system to facilitate the measurement of the ultrasound properties in a Fog medium.

This thesis study can functionally be divided into four principal parts.

- Generation of Ultrasound using piezoelectric transducers.
- Generation and control of a “Synthetic Fog” medium.
- Ultrasound signal reception and storage.
- Data Analysis.

The primary function of the Software system was to initiate the production of ultrasound pulse by controlling a single transducer, sequential triggering of multiple transducers in increasing order of frequency, detect the reflected pulse and filter unwanted part of the signal. The software system acts as an interface between the user control and the hardware system.

The Hardware system was required to generate ultrasound, generate timed fog and facilitate the sequential triggering of the transducers. In addition to that, the hardware system was also required to time the triggering of transducers in an alternating fashion for the generation of ultrasound. The objective of this thesis study was to design various components of the Software system and the Hardware system and integrate both of the systems to provide one unit that would control, receive and analyze the various parameters required to characterize ultrasonic wave in a “Synthetic Fog” medium.

Imaging systems currently use conductive gels to improve skin conductivity to facilitate the use of ultrasound-scanning systems. Such a requirement for an interface between the transducer and the skin can be minimized, possibly reduced if we can improve the medium of conduction. This study will determine whether fog can be used as a medium of conduction to improve ultrasonic propagation.

1.2 Fundamentals of Ultrasound

Ultrasound wave is a non-ionizing form of energy that propagates through a medium as an organized series of interruptions. The nature of these interruptions is an oscillation in the particles of the medium, causing them to be alternately positioned closer to and farther apart from each other. The energy of a sound wave travels away from the source through a series of molecular collisions parallel to the direction of the wave.

The oscillations and therefore the sound wave must be produced by a source and will cross the medium in a straight line until a target is reached. This movement causes a shift in several physical properties of the medium. The velocity of a sound wave depends on the temperature of the medium and its elasticity. The properties of a given medium heavily influence the manner in which sound moves or propagates through it. In the case of ultrasound, the fundamental energy unit is the sound wave.

Ultrasound is useful for imaging structures in the body. Frequency for any application represents a tradeoff between a) spatial resolution, dictating use of higher frequencies, and b) the need to obtain adequate penetration in the tissue. The product between the frequency and its wavelength gives velocity of the wave. Frequency of ultrasound remains constant during propagation whereas the intensity decreases with propagation.

1.2.2 Wave Equation

Several variables are used to visualize and quantify the sound wave. The two most important in terms of ultrasound are amplitude and frequency. Where, amplitude is the change in pressure from rest to maximum compression and from rest to maximum rarefaction. Similarly the cycle used in calculating frequency is the process of shifting from maximum compression to maximum rarefaction and back to maximum compression the length of time for this cycle to occur is called the period. Frequency is calculated as the inverse of period and is a measure of how fast the oscillations occur.

A standard format for expressing these two variables when describing a sound wave is known as the **wave equation**.

$$S(t) = A \cos(\omega t + \theta)$$

Here, S represents sound as a function of time t, amplitude is represented by A, frequency is represented by ω and phase ' θ ' is represented by ' θ '. The audible range for humans is from 20Hz to 20 kHz. The greater the frequency of sound wave the higher its pitch will be. The term ultrasound refers to sound waves above 20 kHz and thus above the audible range of humans. In ultrasound imaging the sound waves used to acquire images of the body range typically from 2 – 10 MHz, beyond the audible range of humans.

1.2.3 Quantitative Properties

In addition to the basic properties of amplitude and frequency, there are several other variables that define a sound wave. These variables can be explained on the basis of time, space and magnitude. The three additional variables describing the properties of sound will be discussed below

1.2.3.1 Time. Period is best described as the amount of time required for one cycle to pass. It is also equal to the inverse of frequency, and measured in seconds. Phase is the amount of offset or delay. This can be expressed with respect to the origin or with respect to another waveform of equal frequency and is measured as a fraction of the full period.

1.2.3.2 Space and Wavelength. Space is the rate at which one point of the waveform progresses through the medium. This is a function of the properties of the medium and is expressed as a distance over time, usually m/s. Wavelength is similar to period, but in the spatial domain. The wavelength describes the distance covered by one cycle of the waveform as it progresses through the medium. It is calculated as the speed times the period. Again, period is the duration of one oscillation while wavelength is the length of one oscillation.

1.2.3.3 Magnitude. Intensity is more commonly used instead of amplitude to quantify the magnitude of displacement imposed by a sound wave. Intensity is equal to the power carried by the sound wave averaged over a given period of time. It represents how "loud" the sound is, and is expressed in decibels.

1.2.4 Pulse-mode

Another common method of ultrasound generation is Pulse-Mode generation or pulsed ultrasound. Pulse-mode is preferred over continuous-mode since it takes advantage of the properties of sound and simplifies the processes of sound generation and detection. Pulse is a short burst of sound containing a few cycles. Each pulse is made up of several sound waves, with different frequency, superimposed upon each other and lasting for few cycles. In pulse-mode, the transducer is triggered to generate pulses of sound at set time intervals

In analyzing the entire signal that is output from the transducer, each pulse is viewed as a single, discrete unit. Instead of treating one full cycle of the continuous sine wave as an event, in pulse – mode one pulse is treated as an event. Thus the same quantifiers used to describe the oscillations in continuous mode are translated to describe the pulses in pulsed-mode.

- **Pulse repetition frequency** - The number of pulses per second.
- **Pulse duration** – Duration required for one pulse to be transmitted.
- **Pulse repetition period** - The time duration between pulses. Duty factor, which is the inverse of pulse repetition period, is another important parameter.

1.2.5 Generation of Ultrasound

Generation of any sound requires the displacement of particles in the surrounding medium to generate an adjustable waveform. Such an activity is achieved by a device known as a transducer. The initial form of energy in ultrasound wave generation is a controlled electrical voltage and the final form is mechanical energy. Materials used to produce this desired activity are called piezoelectric materials.

The Piezoelectric property can be natural to a material or can also be artificially produced. Quartz crystals have a particular form of electrical construction that causes reshaping in the presence of an external voltage. Artificial methods include polarization of a ferroelectric material, followed by heating and slow cooling in the presence of an electric field. Such materials are called polarized ferroelectrics.

The piezoelectric crystals used in ultrasound applications are flat and circular in shape and vibrate at the natural resonant frequency of the material when electrically stimulated. The applied voltage of varying magnitude will cause a sound of varying intensity to be produced at the set frequency of the material.

Resonant frequency is inversely proportional to crystal thickness, therefore in order to change the frequency of the sound generated, a piezoelectric crystal of different thickness must be used.

1.2.5.1 Beam Formation. While a sound wave comprises of a single straight line of activity that moves through its medium, in ultrasound practice many sound waves are used together, encompassing a certain thickness called a beam. A sound beam can be described as the region in front of the transducer that can receive or transmit. The properties of the ultrasound transducer govern the shape of the beam. The radius and resonance are two major properties that affect the beam profile. Resonant frequency is the function of a transducer's thickness, thus the output can be completely controlled by the physical dimensions of the piezoelectric crystal.

The beam generated by the transducer may be considered as the sum of the beams generated by an infinite number of point sources. In the case of sound, each point source

generates sound equally in all directions creating a spherical wave. The summation of these spherical waves forms the beam profile of an ultrasound wave.

An ultrasonic beam converges around a region called the near field and diverges through a region known as the far field up to infinity. Two quantifiers controlling these two regions are the radius of the transducer and its frequency. Adjusting either of the two quantifiers will control the beam profile.

1.2.5.2 Noise. Noise generated in the transducer due to backwardly transmitted sound is reduced by means of providing the transducer with a backing. Particularly in the case of Pulse-Mode ultrasound, the transducer is expected to generate short, distinct sound waves. Backing material allows it to turn on and off quickly without any vibration. Backing element is placed on the side of the transducer across from the beam to be generated. The purpose of a backing element is to absorb vibration from the transducer and to remove any sound directed backwards.

1.2.6 Effects of Medium

At the initial stages of image acquisition, sound is produced by a transducer, introduced into a medium, and allowed to propagate. The target medium and its components govern the events that occur during this period of propagation. In general ultrasound applications, the medium in question is the human body as well as the space between the transducer and the human body. This combinational medium is extremely non-homogenous.

The projected sound wave will interact with the target medium and will return a signal, which will be received at the transducer. The principle interactions that take place between the sound wave and its medium are classified as attenuation and reflection.

1.2.6.1 Attenuation. As sound propagates, the particle oscillations that it causes require energy, causing the wave to lose energy mostly in the form of heat. The wave's intensity is a unitless quantity that is often taken to be unity at the transducer. When expressed in decibels the rate of attenuation becomes a linear function. Each time the sound wave covers a certain distance, a known degradation of intensity will occur. The larger the attenuation coefficient, the more rapidly the intensity of the sound wave will decrease.

1.2.6.2 Reflection. Reflection occurs at the interface between two media with the amount of reflection depending on the acoustic impedance of both. Impedance is mathematically equal to the product of two other material properties namely, density and acoustic velocity. Density is the weight per given volume and acoustic velocity specifies the speed at which sound naturally propagates through a given material.

An interface can be defined as the surface joining two adjacent mediums having different impedance values. However, upon reaching a typical interface, the sound wave will not be reflected entirely, only a fraction of it will bounce back while the remainder will continue to pass in the original direction and into the second medium. The two partial sound waves will have less pressure amplitude relative to the initial sound wave.

$$\mathbf{RF} = \left| \frac{Z_2 - Z_1}{Z_2 + Z_1} \right|$$

Amplitudes of which can be calculated from the above equation where RF is the reflection coefficient and Z_1 and Z_2 are individual impedances of medium 1 and medium 2. Since intensity is proportional to the square of pressure, the same beams can be expressed by their intensities using the same terms. These equations define the behavior

of the initial sound wave upon transmission into a medium and by using these information properties of the medium can be discovered.

1.2.7 Sound Propagation and Interaction with Target

1.2.7.1 Refraction. Sound waves are reflected off of any flat, perpendicular interface. But, the majority of surfaces encountered in the human body do not meet these criteria. The transmitted beam apart from being reflected also undergoes another process known as refraction. The differential impedance causes refraction across the interface. As the sound beam, strikes this interface at a non-perpendicular angle it is slowed at a rate not uniform across its width, causing redirection of the beam.

1.2.7.2 Scatter. Scattering occurs when small imperfections cause seemingly random reflections and refractions of the sound wave in all directions. Scattering can be due to both rough surfaces at impedance boundaries or suspended particles in the medium. The amount of scatter that will occur is dependent on the number of scattering particles, the average size of the scattering particles, and the amount of impedance difference between the particles and its surrounding or adjacent medium. While these imperfections do not greatly degrade the properties of the sound beam, their effects are significant.

1.2.8 dB notation

Unlike frequency, which is a numerically calculable and measurable quantity, the magnitude of the sound wave is a unitless term. In practice, these fractional terms can span a range of exponential proportions, so the decibel format is used. One decibel is an arbitrary magnitude that has been chosen as the standard, base unit for sound.

1.2.9 Mechanisms of Reception

A transducer converts the received ultrasound signals into an electrical stimulus. In this case, the piezoelectric crystals respond to a mechanical deformation caused by sound to produce electrical current. The magnitude of this output is proportional to the degree of deformation of the crystal, which translates to the amount of oscillation in pressure or the intensity of the incoming sound. The greater the sound wave, the greater is the corresponding electrical output.

When ultrasound signals are transmitted and received in pulse-mode, the process is simplified in that the transducer receives separate, discrete pulses of data rather than a continuous stream of information. Each echo pulse is separable and can be stored digitally in both the time and magnitude domains, and the signal can be represented by a sequence of discrete values. Once the sound wave has been converted into this digital signal, it can be computationally analyzed, stored, and otherwise processed by computer in order to ultimately produce an image.

1.3 Introduction to Fog

Various ultrasound applications depend on the particle size distribution of suspensions. The interaction between sound waves and suspension particles is similar to light but sound waves have an advantage that they can travel through concentrated suspensions. When sound wave pass through a particulate system, changes occur to the wave, as well as to the two phases of the medium. A particle presents a discontinuity to sound propagation and wave scatters with redistribution of the acoustic energy through the volume before being detected at the receiver. In addition to scattering, absorption phenomena also occur due to relative particle movement in the suspending medium resulting in a loss of mechanical energy.

The interaction of ultrasound with a heterogeneous dispersed system involves various thermodynamic, hydrodynamic effects. Ultrasound interacts with dispersed medium using six different mechanisms, which are explained below.

1. Viscous mechanism is hydrodynamic in nature and is related to the shear waves generated by the particles oscillating in the acoustic pressure field. The difference in the densities of the particles and the medium creates these shear waves. This mechanism is important for acoustics. It causes losses of the acoustic energy due to the shear friction.

2. Thermal mechanism is thermodynamic in nature and it is related to the temperature gradients generated near the particle surface. Temperature gradients are due to the thermodynamic coupling between pressure and temperature. Dissipation of the acoustic energy caused by thermal losses is considered to be a dominant attenuation effect.

3. Scattering mechanism is essentially the same as in the case of the light scattering. Acoustic scattering does not produce a dissipation of acoustic energy. Particles simply redirect a part of the acoustic energy flow and as a result this portion of the sound does not reach the sound transducer. The scattering mechanism contributes to the overall attenuation.

4. Intrinsic mechanism is the part of acoustics. It causes losses of the acoustic energy due to the interaction of the sound wave with the materials of the particles and medium as homogeneous phases on a molecular level. It must be taken into account when overall attenuation is low which might have happened for the small particles or low volume fractions.

5. Electro kinetic mechanism describes the interaction of the ultrasound with the double layer of particles. Oscillation of charged particles in the acoustic field leads to the generation of an alternating electrical field, and consequently to alternating electric current. This mechanism is a basis for electro acoustics. It turned out that its contribution to the acoustic attenuation is negligible.

1.4 Background

An optimal method of sound velocity determination is to measure the time of flight of a single pulse or consecutive pulses of a resonator in a given specimen of known thickness. The time of flight refers to the time taken by a single pulse or consecutive pulses of a resonator to travel from the excitation transducer to the reception transducer. As an improvement of this conventional method, Neubauer and Dragonette [1] proposed that the distance between the transducer and the reflector be changed in a controlled way, which relates to the change in specimen thickness affecting the corresponding time of flight.

Sound velocity determination in gel-based emulsions, was discussed previously by Ammann and Galaz [2] using through transmission methods. The measurement of sound velocity can be made by placing the specimen between a pair of coaxial transducers of similar frequency characteristics. A pulsed electric signal excites the excitation transducer producing ultrasound wave trains and the response is acquired at the reception transducer.

Each specimen surface generates a pair of intermediate echoes between two successive main echoes. The generated pair of echo can be attributed to the reflection of the main pulse in the forward direction and the backward direction. The full set of echoes is obtained by taking the signal of interest between consecutive main echoes. In the absence of a specimen, the through-transmission configuration generates a train of echoes produced by the acoustic pulse bouncing forth and back between the excitation and reception transducers. The time of flight of the pulses reflected at both specimen surfaces and the distance between these two surfaces will determine the sound velocity.

In order to understand the properties of ultrasound in a fog medium, it is essential to understand the properties of ultrasound in suspensions. Dependence of ultrasonic attenuation on the material properties has been discussed by Babick et al [3]. In a homogeneous media, sound waves propagate straight from the source, thereby steadily losing part of their energy by sound absorption in the medium. In the presence of a heterogeneous media, similar to suspensions a qualitative shift in the character of sound propagation is observed. Each individual particle then behaves as a sound source radiating sound waves in all directions due to reflection, refraction and diffraction. This general wave phenomenon is called scattering.

Sound propagation is primarily influenced by the scattering due to mechanical and thermal coupling effects between the continuous and disperse phase. The mechanical and thermal coupling effects affect sound propagation in two ways 1) They alter the scattering profile 2) Reduce the total amount of the wave due to dissipation. The material properties of phases and the particle size will affect the magnitude of the coupling effects. Scattering as well as dissipation contributes to the extinction of the sound wave in the forward direction causing the measurable sound attenuation.

The total attenuation of sound in a given medium can be described by the following equation.

$$\alpha = \alpha_{int} + \alpha_{th} + \alpha_{vis} + \alpha_{sca}$$

Here α_{int} stands for the intrinsic losses namely the sound absorption in the continuous and disperse phase, α_{th} and α_{vis} describe the thermal and visco-inertial losses, respectively and α_{sca} is the contribution by scattering.

Table 1.1 Description of Material Properties

| Material | Sound speed (m/s) |
|-----------------|------------------------------|
| Water | 1483 |
| Water | 1497 |
| Olive oil | 1440 |
| Corn oil | 1150 |
| Ethanol | 1360 |
| Silica | 2190 |
| Steel | 5250 |
| Oxygen | 316 |
| Carbon-di-oxide | 259 |
| Air | 343.2 |
| Dry Air (0°C) | 331.29 |

The theoretical results show, that in the case of watery dispersions only of the two dissipative coupling processes, thermal and visco-inertial contributes significantly to the overall attenuation [4]. In suspensions with solid particles, the attenuation is almost completely governed by visco-inertial effect, whereas thermal losses can be neglected. In addition the intrinsic losses are only important for low particle concentration.

The following influence the material properties of the attenuation of ultrasound:

Fluid sound speed C_f

Particle sound speed C_p

Absorption coefficient α_f and α_p

Density of the fluid ρ_f and ρ_p

Viscosity of the fluid η_f

Thermal conductivity τ_f and τ_p

Thermal expansion coefficient β_f and β_p

Specific heat c_{pf} and c_{pp}

The densities, the particle expansion coefficient and the particle heat capacity affect the ultrasound propagation properties considerably. The temperature can affect acoustic behavior of dispersions and material properties markedly as shown elsewhere [5]. Some of the required material properties show a considerable dependence on temperature, in particular viscosity, thermal expansibility and the sound speed. Also it has been concluded that the most convenient type of material for ultrasound propagations are watery suspensions with high-density contrast. Such systems require the knowledge of one of the particle properties namely the density to be known accurately.

The principal physical mechanisms are affected qualitatively when going from coarse particles into the submicron range, where the acoustic conditions are called long wavelength regime. In this regime, the acoustic attenuation behavior is mainly governed by dissipative processes, which depend on a variety of material properties. For watery suspensions, it could be shown that the material properties with the highest influence of calculated particle size distribution are the particle and fluid density, the thermal expansion coefficient of the fluid and the particle heat capacity. The fluid sound speed and the particle concentration show significant influence too.

1.4.1 Extinction Co-efficient

Extinction co-efficient can be defined as a measure of the ability of particles or gases to absorb and scatter photons from a beam of light; a number that is proportional to the number of photons removed from the sight path per unit length. The extinction coefficient at the molecular level is an important intrinsic property and is extensively used in quantitative analysis of various materials. The sum of the absorption coefficient and the scattering coefficient gives the extinction coefficient. The standard unit of the extinction coefficient is fraction per meter (/m).

The dissipation of radiation within a surface or medium is caused by the conversion of radiant energy to a different form of energy; usually heat, by interaction with matter. The ratio of the total absorbed radiant or luminous flux to the incident flux is called absorptance. The Standard unit of absorptance is percentage (%). The fraction of energy absorbed per unit distance in a participating medium is called the absorption coefficient. One standard unit for the absorption coefficient, scattering coefficient is fraction per meter (/m).

CHAPTER 2

IMPLEMENTATION

2.1 Materials and Methods

The principal objective of this study was to design and integrate the necessary hardware and software components to provide an experimental system, which will generate, receive and process ultrasound waves in the “Synthetic Fog” medium. Such a system can then be used to compare the propagation properties of ultrasound such as ultrasound intensity, velocity and frequency in air and fog. The experimental system was required to perform synthetic fog generation, ultrasound generation and analysis.

Previous studies have showed that particle size affect the propagation of sound waves in a suspension [6] therefore, particle size of the synthetic fog produced plays a vital role in the study. Also, temperature is found to be another influential factor in sound propagation [7]. Finally, the generated fog should be density controllable. These conditions necessitate that the synthetic fog generating system, to generate fog of desired particle size and density at the optimum temperature.

In order to make ultrasound measurements in fog, we developed a fog chamber fixed with absorption material that will prevent the reflection and scattering of ultrasound waves from the walls surrounding the chamber. The target was chosen taking into consideration energy losses due to scattering. This chapter describes on the software and hardware system developed for data collection.

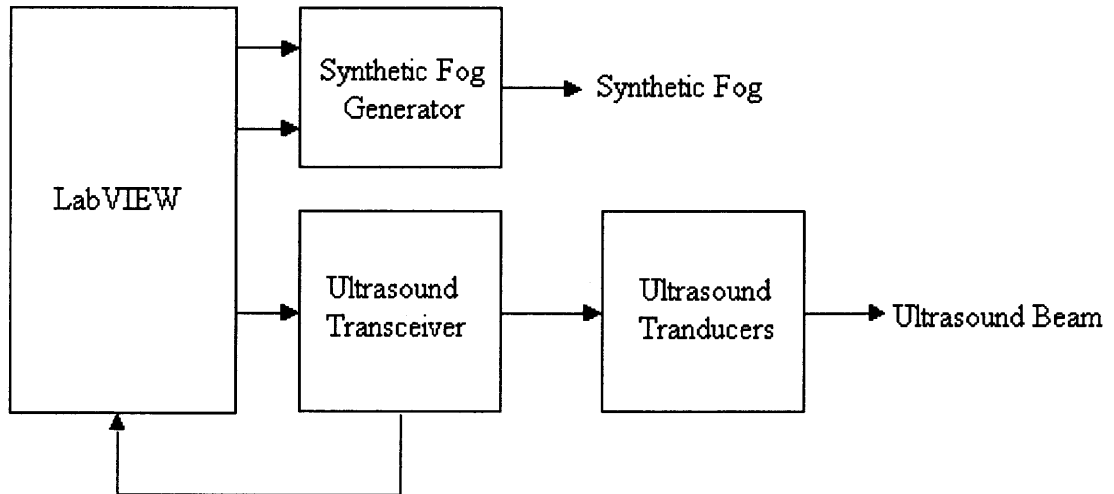

Figure 2.1 Block diagram of the overall experimental setup

2.1.1 System Description

The experimental setup consists of the software programs controlling the hardware, which includes the synthetic “Synthetic Fog” generator and transceiver module. Figure 2.1 shows the overall experimental setup explaining the transfer of control between the Hardware system and the Software system. The software was required to send two digital control signals to the “Synthetic Fog” generator. The first digital control signal controls the fog fluid. Once the optimum temperature was reached, a ready signal was sent to the software system. LabVIEW program sends the trigger signal to the “Synthetic Fog” generator. The software system also controlled the timing of the synthetic fog in order to control the density of the fog in the fog chamber.

The hardware includes the synthetic “Synthetic Fog” generator, the transceiver module, which controls the eight piezoelectric transducers, and the eight individual transducers (30KHz, 41KHz, 50KHz, 75KHz, 125KHz, 200KHz, 225KHz, 300KHz) that produce ultrasound waves.

A hardware interface was developed to switch the transducers sequentially which will be discussed later in this chapter. Such an interface acts like a multiplexer enabling the user to choose between one among the eight output channels to send the analog signal, which will then trigger the transducer.

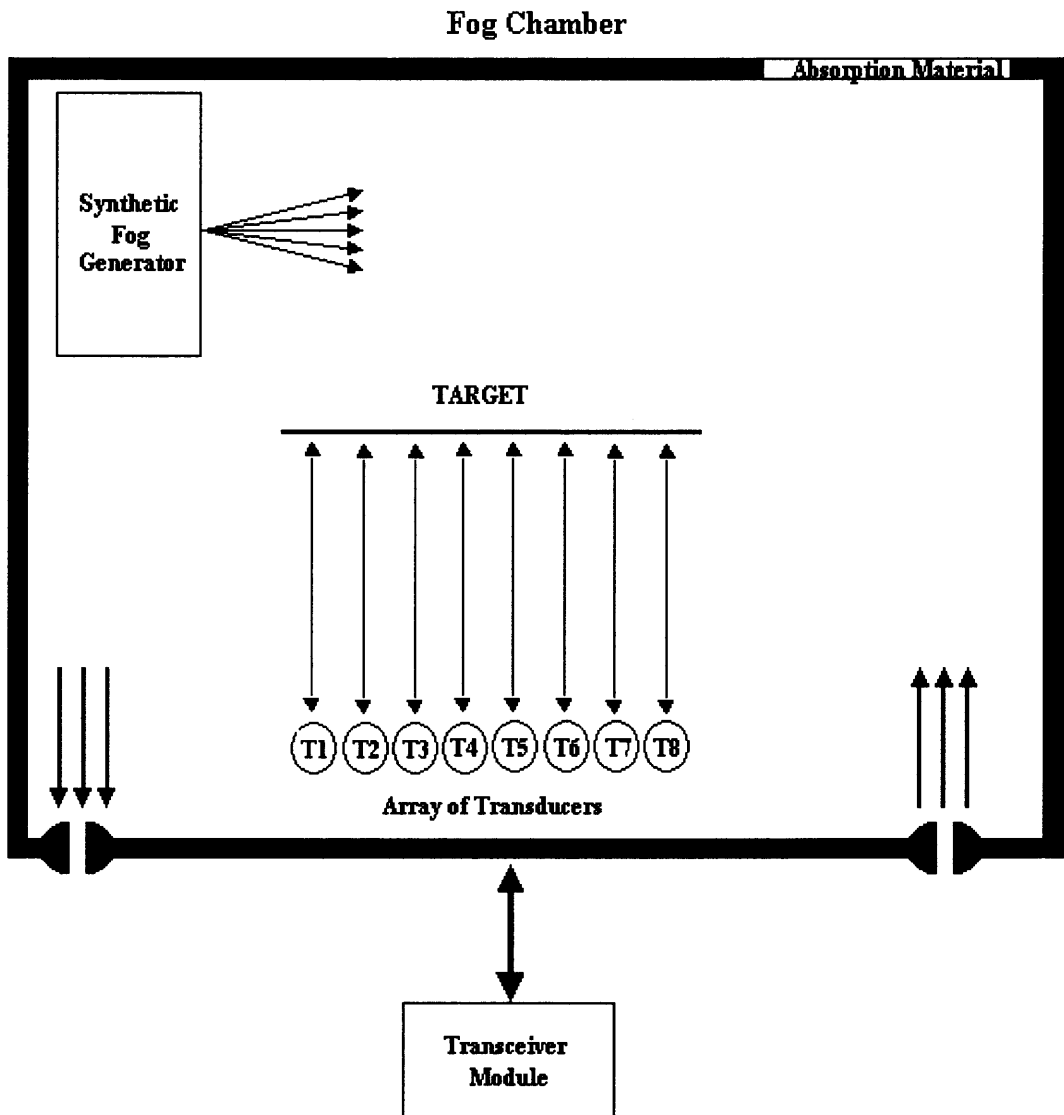

Figure 2.2 Block Diagram of the Fog Chamber

2.1.2 Software Selection

Automation of the hardware components and processing of the analog ultrasound wave signals are the two primary functions required of the software system. The term ‘Software System’ in this report refers to the individual programs, which will initiate and control the generation of synthetic fog and the ultrasound waves for analysis. Proper selection of the software and hardware to design the experimental system forms the backbone of the experimental setup.

The following functions are required to be controlled by the software chosen:

- Trigger the synthetic fog device for varying intervals of time and maintain different desired fog levels in the fog chamber.
- Sequentially trigger the eight transducers.
- Receive and store ultrasound signals from the transceiver.
- Monitor the hardware for fault and alarm signals.
- Provide the user with the necessary feedback to run the experiment.

In order to perform the above functions, LabVIEW (Laboratory Virtual Instrument Engineering Workbench) version 7, multitasking data acquisition software by National Instruments was chosen. LabVIEW is a graphical development environment for signal acquisition, measurement analysis, data display, presentation and storage as well as troubleshooting. This software uses dataflow programming, where the flow of data determines execution through programs called virtual instruments.

LabVIEW as a data acquisition software consists of two work areas namely the front panel and the block diagram to create a complete program or a Virtual Instrument. Every VI uses functions that manipulate input from the user interface or other sources

and displays that information or saves it to other files or other computers. The goal of the software is to create a user environment where the front panel serves as the user interface similar to the front panel of electronic instruments. The front panel provides the user with the necessary controls and indicators, which are the interactive input and output terminals of the VI.

The block diagram simulates as the electronics of the instrument and contains the graphical source code that defines the functionality of the VI. In a similar fashion, front panel is user-friendly because it can be used to control and change the parameters of the virtual instrument and monitor the performance of the system. The block diagram provides the user with a developmental area where the user is provided with a wide variety of design and development tools. After building the front panel, necessary coding is done in the block diagram. The block diagram is coded using graphical representations of functions to control the front panel objects. The block diagram contains this graphical source code. Front panel objects appear as terminals on the block diagram.

The front panel is provided with a special tool called the control palette, which contains the controls and indicators used by the user to create the front panel. The block diagram has functions palette, which contains the VIs and functions used to build the block diagram. Both the work areas are provided with another tool namely the tools palette. A tool is a special operating mode of the mouse cursor. The cursor corresponds to the icon of the tool selected in the palette.

2.2 Fog Control Software Development

The software protocol as mentioned previously was required to perform two functions; control the excitation of the transducers and also trigger the “Synthetic Fog” generator. Development of these codes was based on certain basic considerations. The fog control software consists of two parts 1) Arming and 2) Triggering. Figure 2.3 shows the synopsis of software development to control fog. The following steps explain the software system in detail.

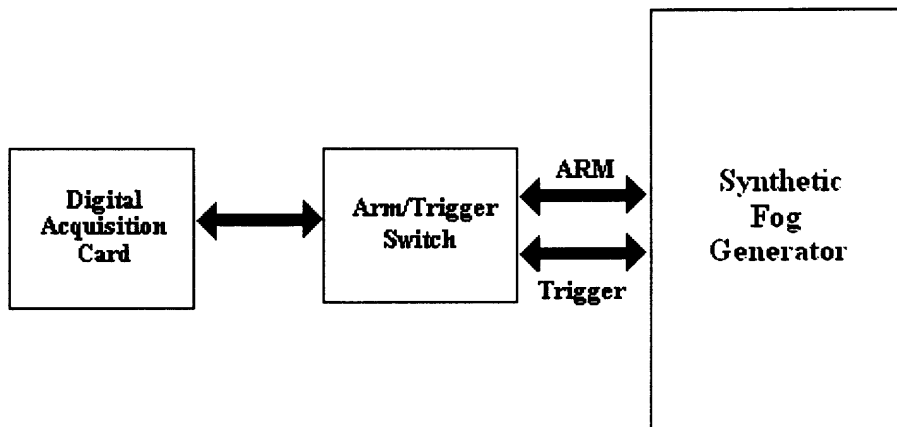

Figure 2.3 Block diagram explaining the control of “Synthetic Fog” generator

The Digital Acquisition Card DAC PCI –MIO-16E is used for data acquisition and control throughout this study. The first few steps send out signal to the Panel Input/Output Board that acts as an interface between the computer and the “Synthetic Fog” generator enabling control transfer between the software system and the hardware system.

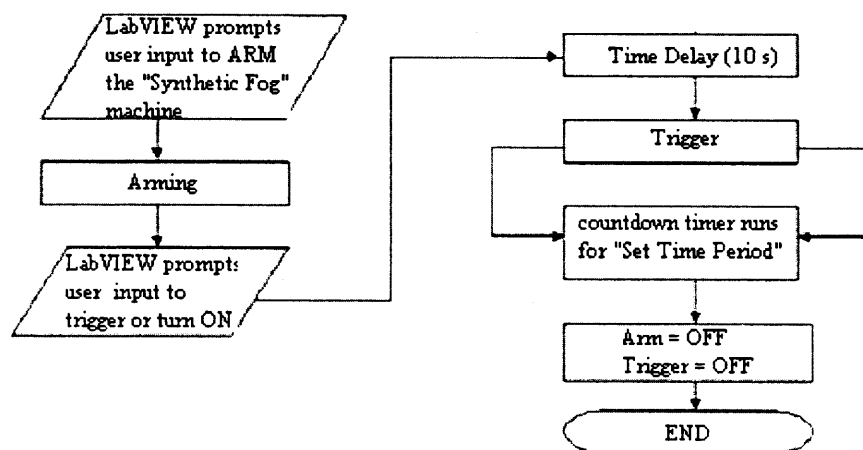

Figure 2.4 Flow chart for software control of the “Synthetic Fog” generator

- Then the “arm” signal is sent to the control switch, which then arms the synthetic “Synthetic Fog” generator.
- After warming up, the “Synthetic Fog” generator sends a “ready” signal to the Panel Input/Output Board. The interface board then sends the signal to the digital acquisition card in the computer, which is then recognized by the software system.
- After receiving the ready signal from the “Synthetic Fog” generator, the user is given a choice to trigger the “Synthetic Fog” generator. After the user’s input, the DAC card sends a second digital signal to the Panel Input/Output Board, which in turn triggers the “Synthetic Fog” generator.
- The presence of a software timer precisely determines the duration of the fog being turned on in the fog chamber. As mentioned before, the duration for which the fog is ON determines the density of the fog in the fog chamber thereby affecting the properties of ultrasound. Provided in the front panel display is a control for the user to select the time duration for which the fog is ON.

the front panel display is a control for the user to select the time duration for which the fog is ON.

2.3 Ultrasound Generation and Acquisition

The second part of software development is comprised of the ultrasound generation and acquisition. Figure 2.4 describes the process of ultrasound generation and data acquisition. The DAC card in the computer sends out digital signals to the transceiver module that in turn triggers the individual transducers through the switching circuit.

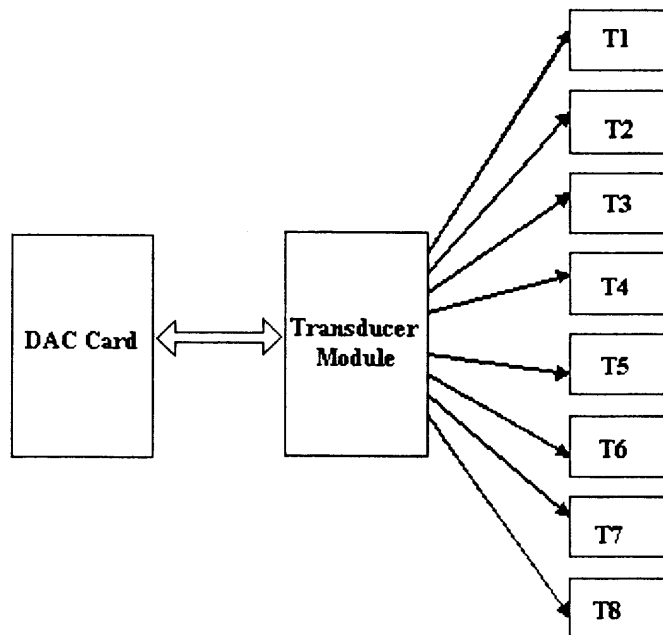

Figure 2.5 Block diagram explaining control of transducers and data acquisition

The first few steps perform the analog input configuration which includes AI configure, AI start and AI read as a part of the configuration of the system. AI Configure VI configures an analog input operation for a specified set of channels. This VI configures the hardware and allocates a buffer for a buffered analog input operation. “AI start” begins a buffered analog input operation. This VI sets the scan rate, the number of scans to acquire, and the trigger conditions. The VI then starts an acquisition. AI Read

Reads data from a buffered data acquisition. “AI Read” can be configured to output binary arrays scaled array and waveforms. LabVIEW controls the triggering through a switching circuitry that switches the transceiver module between the transducers.

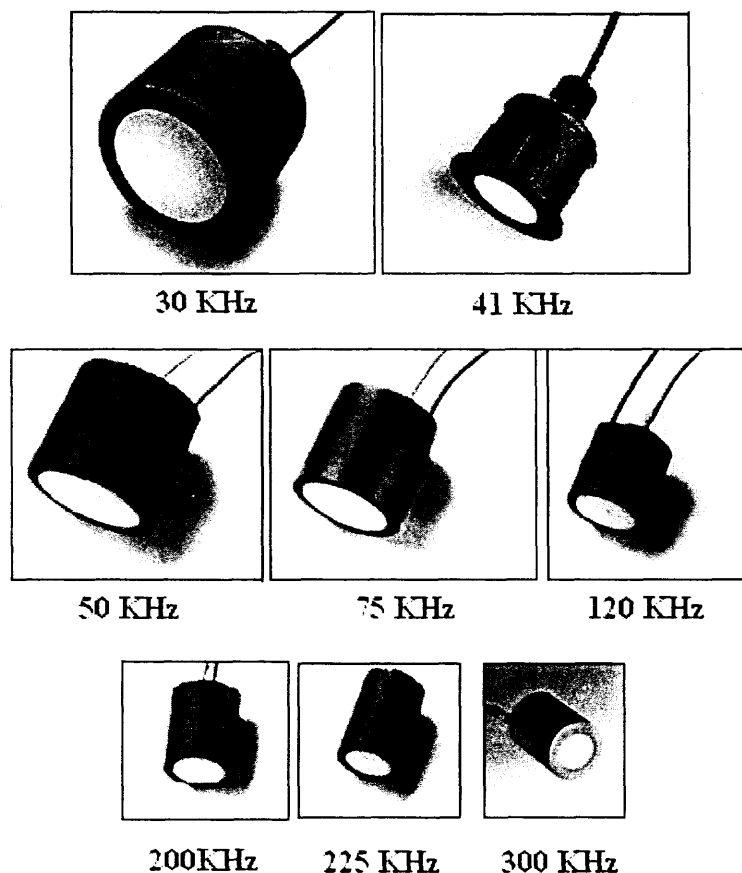

Figure 2.6 Picture of the eight transducers chosen for the study

2.3.1 Conditional Retrieval

The transceiver module is triggered by means of a 12 V supply that in turn sends a pulse to the respective transducer through the switching circuitry. The transducers often being triggered send out pulsed ultrasound waves out to the target and receive the reflected waves. Before storing the ultrasound waves the signal needs to be processed.

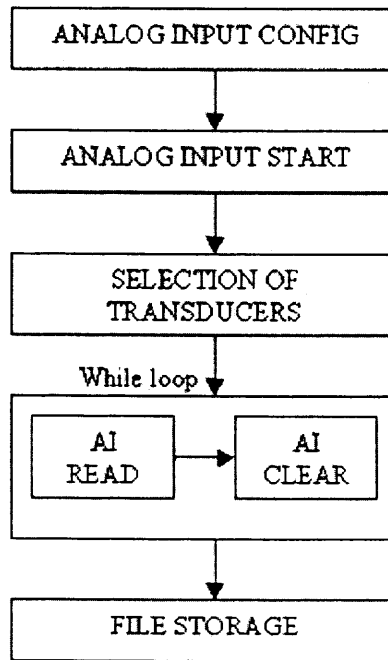

Figure 2.7 Flow chart explaining the software control of the transducers

The conditional retrieval VI sets parameters so as to receive and store only those signals that have useful information in them. The trigger level, trigger slope trigger channel are given as input to the VI chop the undesirable signals. By setting the trigger level, the VI starts recording the data received above the threshold of the trigger level. Thus this VI helps in storing data relevant to the experiment.

2.4 Fog Generation and Timing Control

The “Synthetic Fog” generator is enclosed in a 14 (length) x11 (width) x 18 (height) casing and is 50 lbs in weight, and powered by 120 V/AV power supply. It is provided with two heaters of 750 Watts that are provided to heat the fog fluid to raise the temperature of the fog fluid to the optimum temperature of 345- 350° C

Two batteries of 12V/DC capacity are provided for back up purposes. Initial warm up time for the heaters to heat the fog fluid for fog dispersal is 15 minutes. A fluid pump of 24 VDC power is used to pump the fluid through the “Synthetic Fog” generator system during dispersal. On the display, one of the indications provided to the user is the low fluid indicator. This is made possible by a low fog fluid probe that indicates the presence or absence of fluid by means of enabling a local buzzer. Also, the output signal is connected to the alarm panel.

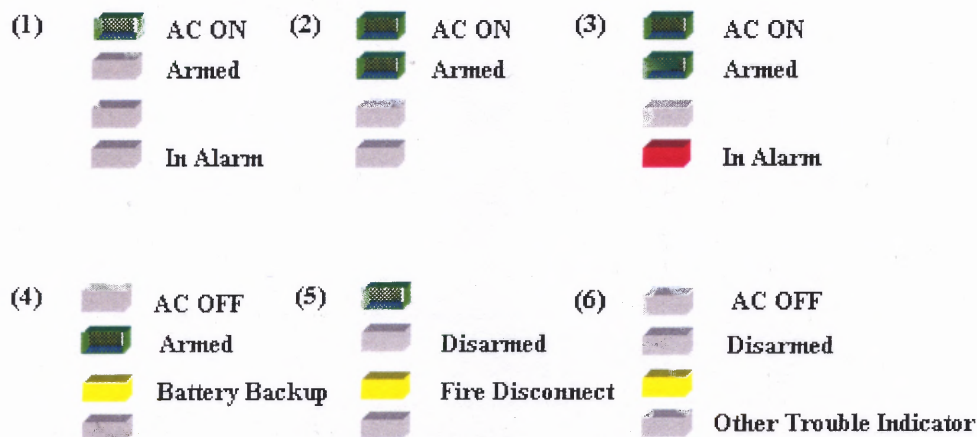

Figure 2.8 LED signals showing the different combinations in the display panel

Activation duration refers to the time duration for which the “Synthetic Fog” generator produces fog of 0.1 sec increments. The output capacity of the “Synthetic Fog”

generator is 60,000 cubic feet per minute (1,699 cubic meters). This calculation is used later in data analysis to calculate the density of fog in the chamber.

2.4.1 Panel Input/Output Board

The panel input/output board acts as the interface between the user and the “Synthetic Fog” generator. It provides the user with four different outputs to control the “Synthetic Fog” generator. RJ 45 connections utilize standard CAT 5 straight through patch cables and connect the “Synthetic Fog” generator with the interface board.

2.4.1.1 Control Outputs

Trouble – The trouble output indicates the presence of any alarm. When the “Synthetic Fog” generator is initialized, the EEPROM checks the various parameters required to produce the fog successfully. In the presence of a failure at any of the system components, the trouble relay is energized and the user is notified of the presence of a failure in the system. Though the trouble relay energizes in the presence of trouble the system does not specify the type of error occurred.

Heat Ok - On arming the “Synthetic Fog” generator, the fluid temperature is raised so as to get the most homogeneous suspension possible. The optimum temperature required by the fog generation system is 345 – 350° C. Once the fluid has reached the optimum temperature, the heat OK relay is energized by the EEPROM and is indicated to the user by means of an LED.

Fog ON – On receiving the Heat OK signal, the user can trigger the fog which will initialize the generation of fog. The Fog ON relay energizes in the presence of fog in the fog chamber.

Fluid LOW – The user needs to check the presence of the fog fluid in order to ensure continuous and homogenous production of fog in the fog chamber during an experiment. The absence of minimum requirement of the fog fluid, will lead to generation of fog in irregular bursts. In order to ensure proper fog generation, the fluid LOW relay energizes in the absence of adequate fog fluid to start fog generation.

2.4.1.2 Control Inputs. The “Synthetic Fog” generator can be controlled through the interface with the help of two controlling inputs. Both inputs become active when closed.

ARM – Arming of the “Synthetic Fog” generator is controlled by the software through the interface with the help of a 5V normal open relay.

FOG – After heating the fog fluid to the desired optimum temperature the “Synthetic Fog” generator sends out a signal to the interface indicating that the fog fluid has been heated to the desired temperature. After receiving this signal from the interface, the “Synthetic Fog” generator can be turned ON or triggered, by sending a 5V signal to the interface, which will then send a signal to the “Synthetic Fog” generator to turn on fog generation.

2.4.1.3 Keyboard Control. In addition to the interface, the “Synthetic Fog” generator can also be controlled with a PS/2 Basic keyboard. The keyboard primarily is used to control the initial system parameters when the “Synthetic Fog” generator is powered ON. There are four different control options provided to the user. First of which is the date and time settings which after initializing the experiment sets the current date and time in the “Synthetic Fog” generator. Settings 2 and 3 are factory presets and therefore the user has no control over them. The Fourth setting is the operation settings which provide

control to the user in order to set the initial run time, burst timing, consecutive burst timing and repeats after initial burst is also provided as one of the operation settings which will enable the “Synthetic Fog” generator to be programmed for a set pattern of bursts. This option ensures homogenous generation of fog.

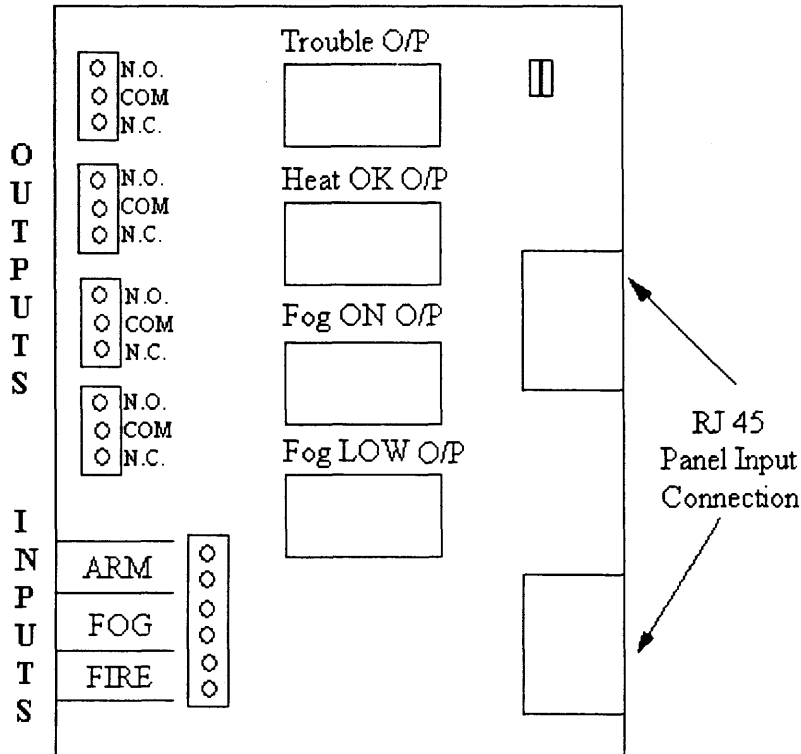

Figure 2.9 Panel Input/Output Board

2.4.2 Fog Activation Duration

The quantity of fog output is adjusted to the size of the area to properly predict the density of fog produced in the fog chamber. The Factory setting is for 1 minute initial Fog, wait 2-3 minutes and burst for 2 seconds repeated 4 times or until alarm is turned off (1 second = 1,000 cubic feet).

2.5 Ultrasound Hardware Selection and Evaluation

In order to collect ultrasound parameters, the transducers were required to operate over a range of frequencies instead of being operating in a specific peak frequency. Diagnostic ultrasound applications utilize a frequency range between 1-5 MHz. Reception of ultrasound waves in the Megahertz range is restricted to a few centimeters and therefore was not chosen. Optimum range for the study was found to be in the Kilohertz range where the ultrasound waves can travel from centimeter to a few meters. This way the fog chamber was utilized to its fullest in obtaining data for analysis. The generation of ultrasound is achieved with the help of eight piezoelectric transducers covering a frequency range of 30 KHz to 300 KHz. Each of those transducers operates ± 4 KHz around its operating or resonance frequency.

Sequential triggering of the transducers was accomplished by two methods of switching. The first of the two methods uses a multiplexer to trigger the transducers sequentially. After choosing the address pins on the multiplexer chip alternately, one of the eight available output pins was enabled which then triggers one transducer at a given time. The multiplexer was found to allow noise signals through the other seven outputs. Thus, enabling one output a switching circuitry was designed to eliminate the noise.

The type of target material played a vital role on the quality of the received signals. The point of consideration was to choose the kind of material that would reflect maximum incident waves with minimum scattering. In this study, a glass mirror was used as the target material as recommended by the manufacturer of transducers.

2.6 Transducers Description

The selection of transducers is based on the sensor performance, acoustic beam characteristics and driving circuitry. A transducer's performance can be affected by the propagating media, environmental conditions and the electronic circuitry used to drive them. Eight piezoelectric transducers were required for experimentation. The following transducers 30 KHz, 41 KHz, 50 KHz, 75 KHz, 120 KHz, 200 KHz, 225 KHz, 300 KHz were bought from Airmar Technology Corporation. Piezoelectric transducers are best suited for this study since they present a combination of efficiency, design flexibility and cost efficiency.

Discovery of the piezoelectric effect in 1880 is credited to Jacques and Pierre Curie. This phenomenon is exhibited by certain materials, which develop an electrostatic potential when subjected to pressure and, reciprocally, mechanically deform when subjected to an electrostatic potential. Certain naturally occurring crystalline substances (for example, quartz) inherently exhibit the piezoelectric property. Synthetic piezoelectric materials can be manufactured using polycrystalline ceramics, or certain synthetic polymers.

Piezoelectric transducers are electromagnetic devices that convert electrical energy to mechanical energy and vice versa. The transducer converts a high voltage electrical pulse at a given frequency into mechanical vibration. The sound wave intercepts one or more targets within its path and a portion of the energy is reflected back to the transducer as an echo. The received echo mechanically deflects the transducer, producing a low voltage return signal, which is then amplified and processed by the receiver electronics. Since the speed of sound remains relatively fixed (at approximately

4800 feet per second in water), it is possible to determine the distance to the target by accurately measuring the time difference between the transmitted pulse and the received echo as shown in figure 2.7.

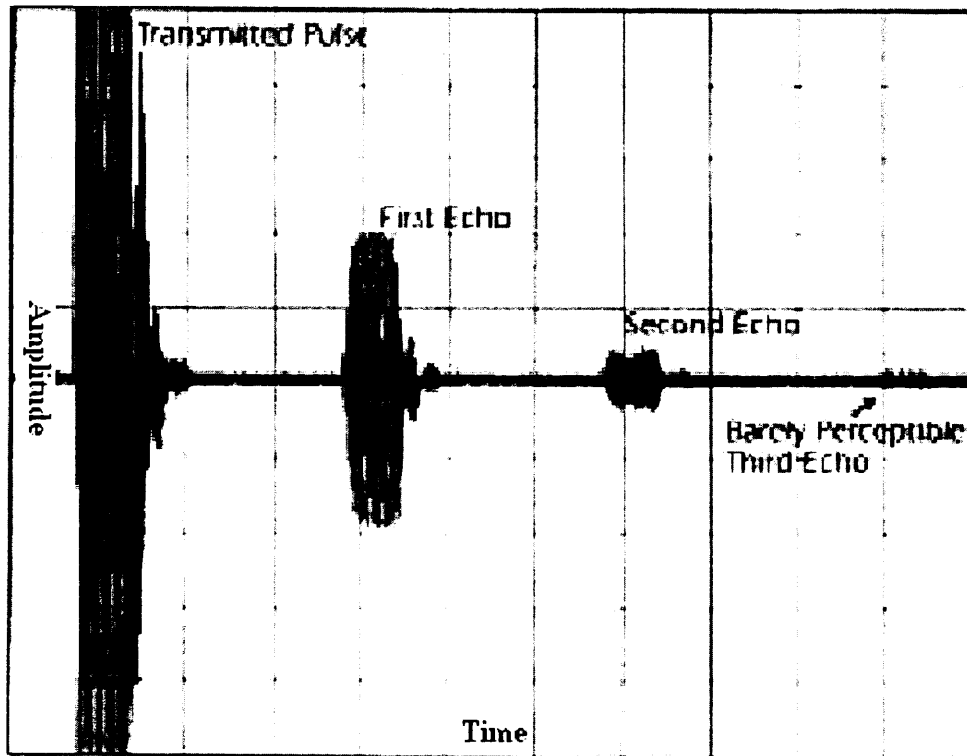

Figure 2.10 Excitation and reception signals with first and second echo are shown above

A typical piezoelectric transducer is fabricated by wrapping a resonant piezoceramic material in a suitable pressure release material such as cork or foam, placing the ceramic in a suitable housing, connecting a shielded cable to the silvered electrodes on the ceramic, and filling the housing with an appropriate encapsulation material.

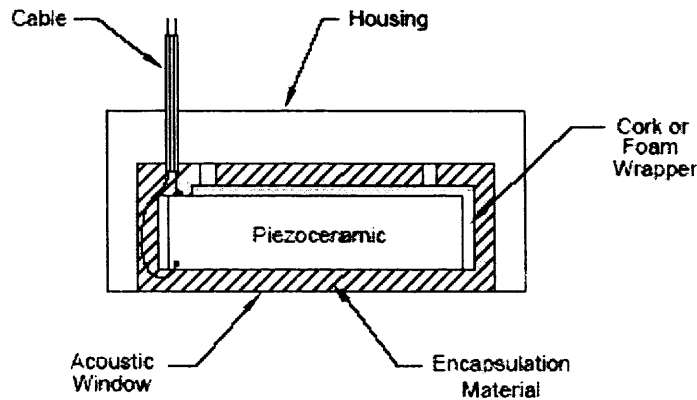

Figure 2.11 Encapsulation of a piezoceramic material to form transducer

Piezoelectric transducers have at least one series resonant frequency at which they vibrate. The equivalent circuit representing the resonant frequency is shown in the figure below. Here, R , C , and L represent the mechanical resonance of the transducer. R represents the transfer of energy into the medium and the mechanical losses of the transducer. At resonance, the energy stored in the transducer is being transferred back and forth between C and L , and the magnitude of the impedance is at a minimum determined by R . It is at a point near this resonant frequency the transducer is most efficient.

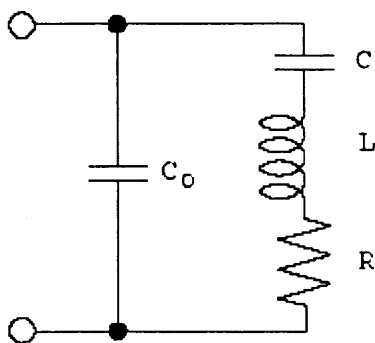

Figure 2.12 Transducer equivalent circuit

2.6.1 Maximum Sensitivity

Several factors have an effect upon the sensing range of a transducer. When designing an ultrasonic system, several factors should be considered beyond the transducer itself. These factors include atmospheric conditions, transmit and receive electronics and signal processing. These factors are discussed briefly.

2.6.2 Temperature and Humidity

Figure 1: Attenuation in Air at 1 Atmosphere at 100KHz

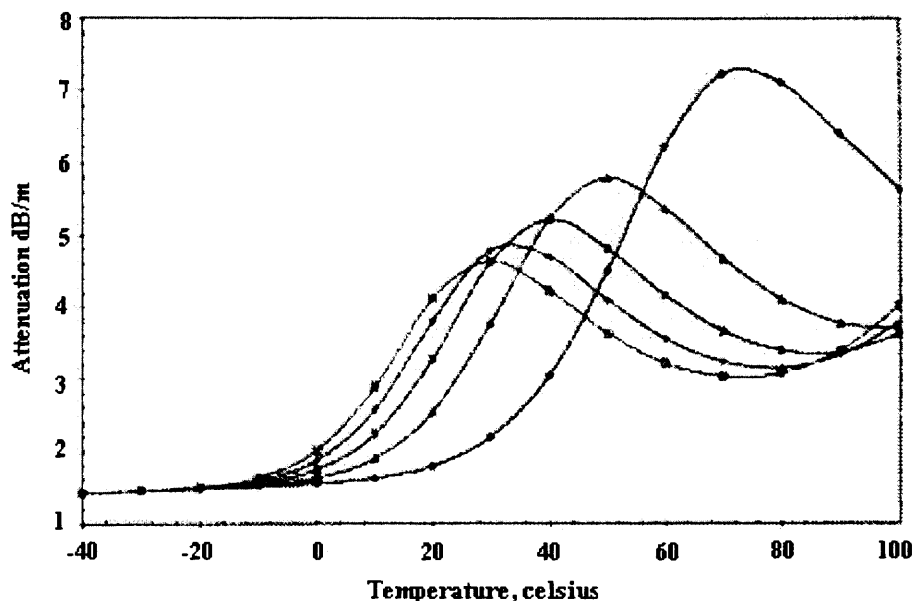

Figure 2.13 Signal attenuation as a function of temperature, frequency and air pressure

Changes in temperature cause a change in sound speed of air as well as the materials of any ultrasonic transducer. The transducers used for this study are specified for operation at 25 °C. Operation at significantly higher or lower temperatures will result in “detuning” of the acoustic matching layer of the transducer and shifting of the resonant frequency resulting in degraded performance. The above figure represents the signal

attenuation as a function of temperature, at a frequency of 100 KHz and 1 atmospheric pressure.

2.6.3 Interference (Electrical and Acoustical)

Proper shielding should be provided in order to prevent the degradation of performance of the transducer due to electrical and acoustical interference. Proper mounting of transducers was given enough importance in this study to avoid mechanical coupling interference.

2.6.4 Target Strength

It is known that hard, smooth and flat targets mounted orthogonally to the incident beam provide strong reflected waves and will exhibit this properties at longer ranges. If the beam is not orthogonal, it will be reflected off at the angle of incidence and not be received by the transducer. Rough and irregular surfaces return a signal of varied amplitude.

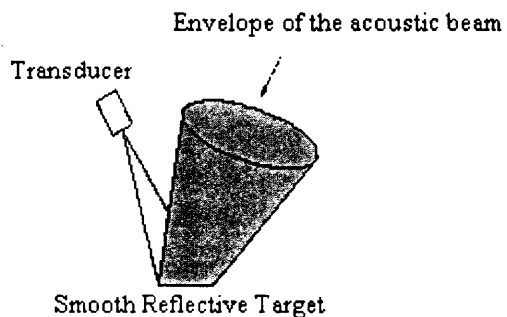

Figure 2.14 Influence of target material and target angle on the incident beam

2.6.5 Beam Angle

A transducer transmits energy in a beam pattern. Most of the energy is concentrated in the main lobe, which defines the beam width. Energy outside the main lobe is concentrated in side lobes, which can disguise the true location of targets by generating phantom echoes. Wide beams spread acoustic energy over a greater volume and hence less acoustic energy is reflected from potential targets than from a narrower, more concentrated beam.

2.6.6 Minimum Sensing Range

The distance from the active surface of a transducer to the minimum sensing range is called the Blanking Zone where there is no signal reception. The blanking zone is due to a phenomenon called ringing. Ringing is the continued vibration of the piezoelectric transducer element beyond the electrical excitation pulse. The type of electrical pulse used to drive the sensor can have a profound effect the amount of ring. A transducer has many modes of vibration. When designing a system, the objective is to drive the transducer at a frequency strongly coupled to air and avoid extraneous resonances. Hence, the use of a tone burst (narrow bandwidth) is beneficial. In contrast, the use of a wide-band transmitting scheme can excite undesirable vibration modes.

2.6.7 Mounting

Since the transducer is an electromechanical device, some vibrational energy is transmitted to the transducer housing. A compliant mount typically has the least effect on sensor performance. Mounting the transducer on the outside diameter of the housing could cause an increase in ring time.

2.7 Switching Interface

The switching interface consists of a multiplexer an inverter and sixteen relays. The function of the switching interface was to control the sequential triggering of the transducers. This enables storing of data received from the transducers in a sequential fashion. The figure below shows the complete set up consisting of 16 relays. The operation of the switching interface is better explained with the help of figure 2.16.

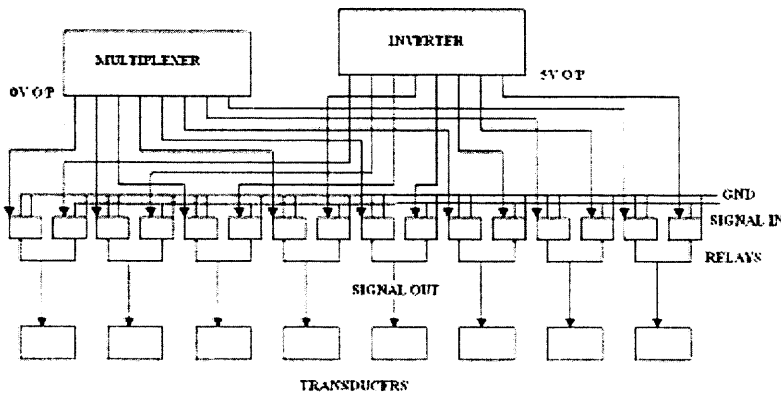

Figure 2.15 Block diagram explaining the operation of the switching interface.

- Control of the switching interface corresponding to one transducer is shown in figure 2.16. The multiplexer is fed digital output at the address pins. Depending on the combination of the digital input, the corresponding output pin is chosen. The output at the chosen output terminal was 0V.
- Two output leads are taken from the output pin under consideration and one is fed to the inverter and the corresponding output at the inverter terminal is inverted.

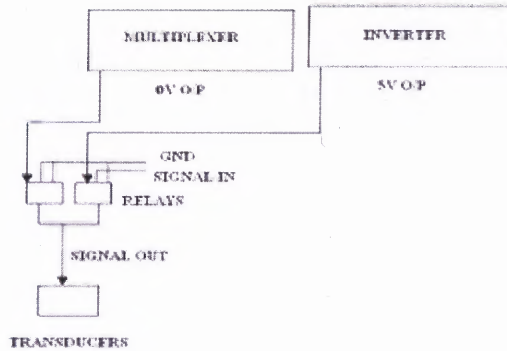

Figure 2.16 Switching interface controlling one transducer

- The other output is fed to one relay of the relay pair. The inverted output from the inverter is fed to the other relay in the relay pair.
- The relay pair consists of two relays, where one relay acts as ground relay and the other relay acts as signal relay. The ground relay is pulled to ground and the signal is fed through the “Signal Relay”.
- The output from the “Signal Relay” is fed to the transducers. By changing the address pin selected by the digital output, corresponding transducer can be selected.

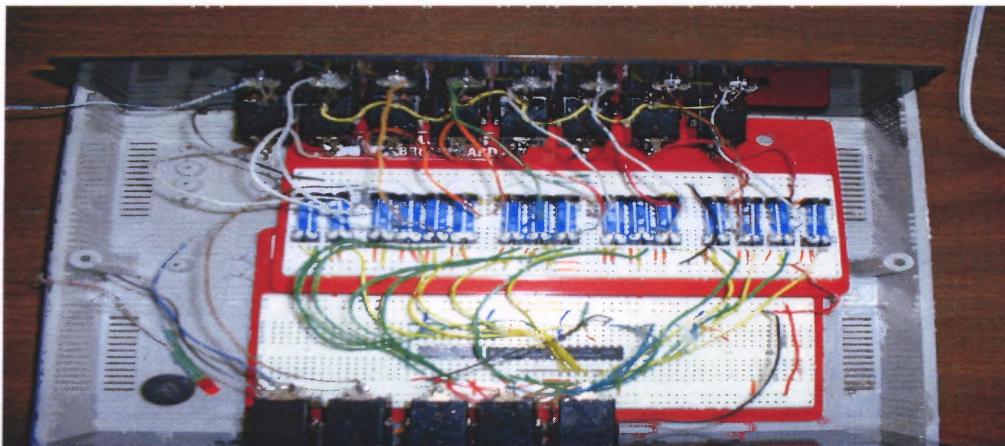

Figure 2.17 Picture of the switching interface

CHAPTER 3

SAFETY

3.1 Introduction

Since this research study was conducted to study the characteristics of ultrasound in a medium of “Synthetic Fog”, it becomes inevitable to understand the adverse effects of these primary factors. The health of the personnel working in a fog environment needs to be taken into consideration before initiating data collection. This chapter discusses the effects of both synthetic fog and ultrasound on the health of humans.

3.2 Fog and Safety

One hundred years ago steam was used in large theaters to safely simulate smoke. Later chemical means were increasingly used to generate fog. The noxious fumes produced by fireworks and other pyrotechnic devices yielded problems in terms of control and safety leading to the generation of fog machines.

The first fog machines all hinged around heating mineral oil. The problems with these oil-based machines were that they are mildly toxic and the droplets emitted were at a very high temperature and could burn. The fog was often foul smelling producing deposits on surrounding equipment. Fog produced by atomizing alcohols (such as glycols and glycerin) is dense, white and odorless and therefore replaced older methods. Over the last decade, there has been numerous research on the effects of artificially simulated fog on personnel health.

3.3 The Characteristics of Glycol-Based Theatrical Fogs

The most common fog-generating techniques create suspended liquid aerosols (fogs), using heat or mechanical methods. Fog machines generate a fog by introducing a water/glycol mixture to a heating element, then forcing the ensuing fog through a delivery port or nozzle into the local environment. The heating element may be either a coiled copper tube or a metal heating block. The element is heated to temperatures specified by the manufacturer, typically in the range of 218° to 370° C (425° to 700° F). The heated solution becomes airborne as a vapor and is then expelled from the nozzle of the unit, cooling into a finely divided, opaque aerosol. Mechanical methods include atomizers and ultrasound. Atomizers work by forcing air through a dispersion system with small holes submerged in the fogging solution. The air breaks the surface of the fluid and disperses small droplets (10 - 20 microns).

From a health perspective, there is an important distinction between the heat-based and mechanical methods. Heat-based methods have the potential to generate additional airborne contaminants in the form of thermal degradation compounds of the parent solution since the temperatures of the solutions may exceed 300°C.

The most common glycol components in theatrical fogs include ethylene glycol, diethylene glycol, triethylene glycol, propylene glycol, dipropylene glycol, butylene glycol, and glycerol [14]. In general, the toxicity of glycols under normal exposure scenarios can be rated as low and are not expected to cause serious health outcomes. Since glycols contain four polyfunctional alcohols, exposure to any of these substances may cause a drying of mucous membranes irritation of the eyes and respiratory tract.

3.4 Previous Research on Theatrical Fogs

A recent analysis of the US National Health and Nutrition Examination Survey (NHANES III) data, found that the entertainment industry was identified with self-reported work-related asthma and wheezing [15]. There have been three studies specifically examining the health effects of theatrical fogs, which are discussed below.

3.4.1 The NIOSH Health Hazard Evaluation

Smoke exposure was studied at four Broadway stage productions by collecting personal and area samples [16]. Ethylene glycol, propylene glycol, triethylene glycol, and butylene glycol were then detected at most of the sampling locations. Concentrations of glycol components ranged from 0.053-7.59 mg/m³. Potential thermal degradation products of glycols were found to be acrolein, formaldehyde, acetaldehyde, acetone, C9-12 aliphatic hydrocarbons, and alkyl benzenes at low levels. One hundred and thirty four actors working in 'smoke' productions had a greater prevalence of nasal, respiratory, and mucous membrane symptoms compared to 90 actors working in 'non smoke' productions.

3.4.2 Consultech Engineering Study

Consultech Engineering carried out a survey in 1993 to investigate perceived health problems reported by actors exposed to glycol fogs [17]. A questionnaire with 50 questions about health problems, exposure levels, impact of health effects on work attendance and performance quality. Almost all (98%) of the respondents had been exposed to fogs, and 77% reported being exposed to glycol fogs. Of those exposed to glycols, 40% reported respiratory and mucous membrane symptoms, 18% had missed a performance, and 33% had sought medical attention because of the symptom severity

3.4.3 Mount Sinai and Environ Study

The University of British Columbia conducted a study on fog exposures [18,19]. The study was a survey, which interviewed 23 members of the international alliance of theatrical stage employees.

3.4.3.1 Chemical Analysis. Glycol based fluids were heated to determine if their heating could have caused the production of additional contaminants and determined that there were no increases in concentrations of typical combustion gases such as carbon dioxide or carbon monoxide, nor declines in the oxygen concentration, indicating that breakdown of the glycol fluids did not occur at this temperature.

Aldehydes were detected as the potential breakdown product, in addition to certain polycyclic aromatic hydrocarbons in a small number of samples. The concentrations were found to be extremely low, similar to the ambient levels in air.

3.4.2.2 Exposure Levels. The exposures of 111 entertainment industry personnel were visited, for a total of 32 sampling days. Results show that the fog aerosols were small enough that a large proportion of them could enter the smallest airways and air sacs of the lungs. These small aerosols can stay suspended in air for long periods, from hours to days. The average fog aerosol concentration measured in the breathing zones of the study subjects was 0.70 mg/m³ (range 0.05 to 17.1 mg/m³). Exposures to aldehydes and polycyclic aromatic hydrocarbons were low, similar to background levels in air.

3.4.3.3 Health effects: The study also monitored the respiratory health of 101 of the 111 persons who participated in the exposure monitoring study. Investigators measured the lung function before and after a fog-exposure period and conducted an interview about lung health. Compared to the control group, the entertainment industry employees had lower average lung function test results and reported more chronic respiratory symptoms: nasal symptoms, cough, phlegm, wheezing, chest tightness, shortness of breath on exertion, and current asthma symptoms, even after taking other factors into account such as age, smoking, and other lung diseases and allergic conditions. Most of these symptoms and decreased lung function were associated with having been exposed to greater amounts of theatrical fog (higher levels and more days of exposure) and working closest to the fog machine.

3.5 Glycol Thermal Degradation Products

Heating of organic compounds to high temperatures is well known to cause pyrolysis, generating decomposition products such as aldehydes (e.g., formaldehyde and acrolein), carbon monoxide, carbon dioxide, nitrogen oxides, and hydrogen cyanide [18]. These products are generated during combustion and/or during prolonged heating of organic materials to high temperatures. Many of the products are asphyxiants and, at lower concentrations, respiratory irritants. Exposure to this class of compounds was originally linked to scrotal cancer in personnel working as chimney sweeps and has now been linked to lung and other cancers. Thermal degradation products of glycols that have been detected in field samples from heat based fog generation.

3.5.1 Dissipation Speed and Density

Dissipation, speed and density are two factors of prime consideration. By altering the relative mixes of the various glycols used, mists can be produced with a large range of dissipation times. Nearly all models of machine have some means of controlling the volume output of Fog, but perhaps important than the actual amount emitted is how it is dispersed into the air

3.5.2 Physical Density or Weight

Fog dissipation units use liquid carbon-di-oxide, dry ice or refrigeration plants to chill the glycol fog approximately to the freezing point. This increases the physical density to make the fog heavier than air so it will sink to the floor or cascade in slow 'waterfalls' giving the effect traditionally produced by solid carbon-di-oxide, dry ice. A different mix of fluid can be used for these 'chilled' machines, designed to evaporate and disappear as the fog warms so it is never seen to rise in the air. The mist produced can be

very short lived and appear and disappear on cue. Ideal perhaps for effects such as rocket ship exhausts or factory scenes where a 'jet' has to be briefly seen but must not subsequently fill the stage or studio.

The fog machine used in this study is built understanding these adverse effects of fog. Any coughing caused is usually purely psychological and the fog contains no toxic elements known to affect the vocal cords. The only temporary effect can be a drying caused by the hygroscopic (water absorbing) nature of glycols.

Table 3.1 Types Of Health Effects Due To Glycols

| Fog Simulant | Health Effects | Recommended Limit |
|---------------------|--|--------------------------|
| Ethylene glycol | Eye irritation ,throat irritation, headache, respiratory irritant | 10 mg/m ³ |
| Diethylene glycol | Eye irritation, skin irritation, respiratory irritant | 10 mg/m ³ |
| Triethylene glycol | Headaches, eye irritation | 10 mg/m ³ |
| Butylene glycol | Dermatitis, eye irritation | 1- 10 mg/m ³ |
| Propylene glycol | Eye irritation, skin irritation | 10 mg/m ³ |

3.6 Relevant Exposure Limits

3.6.1 PEL [Permissible Exposure Limits]

Permissible exposure limits indicate average airborne contaminant levels to which it is believed nearly all workers may be exposed without significant ill effect. PEL values are expressed as 8-hour time-weighted averages defined as average airborne concentrations for an 8-hour workday and a 40-hour workweek.

3.6.2 STEL [Short term Exposure Limits]

Short Term Exposure Limits have been established for chemicals to which short term exposure may produce deleterious health effects. STEL's are typically 15-minute time-weighted average exposures.

3.6.3 Ceiling Limit

Ceiling limits are concentrations, which are not to be exceeded even instantaneously and are given highest importance.

3.7 Conclusions

1) The recommended exposure guidelines are predicated as 8-hour time-weighted averages [15].

2) Although research indicates that only the 1,3-butanediol isomer of butylene glycol is used in fogging solutions, it is advisable to continue using the same since they are less toxic. Given that the 2,3- isomer and, particularly, the 1,4-isomer are significantly more toxic, their use in fogging solutions should be avoided.

3) The chemical nature of glycols is such that prolonged or repeated contact with a glycol mist will dehydrate moist tissues (i.e., the mucous membranes of the upper respiratory tract and, possibly, the eye). In accordance with the requirements of the Hazard Communication Standard, fog-operating personnel working in an environment where exposure to fogs is likely must be educated of the potential outcome of such exposures.

4) Although no research results indicate that skin contact resulting from airborne synthetic fogs has resulted in skin irritation or allergic sensitization, personnel should also be informed that unusually sensitive individuals might experience such effects.

5) Individuals with pre-existing respiratory conditions may be more prone to experience respiratory irritation when exposed to theatrical fogs. Though the recommended exposure guidelines will be sufficient enough to prevent and or minimize the likelihood of any adverse effect, such individuals should be counseled to seek medical advice prior to prolonged or repeated exposure to fogs environment.

3.8 Introduction to Ultrasound Safety

Ultrasound is accepted as being of considerable diagnostic value. There is no evidence that diagnostic ultrasound has produced any harm to patients in the four decades that it has been in use. However, the acoustic output of modern equipment is generally much greater than that of the early equipment and, in view of the continuing progress in equipment design and applications, outputs may be expected to continue to be subject to change. The potential bioeffects of ultrasound result from two major mechanisms, thermal and mechanical.

3.8.1 Thermal Effects of Ultrasound

Heating effects are dependent upon the acoustic energy delivered per unit time to a particular tissue area. The best indicator of the amount of heat delivered to a tissue by ultrasound, is the spatial peak temporal average intensity, which is the maximum intensity occurring in the ultrasound beam averaged over the pulse repetition period. The heating of the tissue is also dependent upon how fast heat is removed from the tissue. Factors affecting heat deposition in a tissue are the absorption coefficient of the particular tissue, the transducer frequency, focusing of the ultrasound beam, whether the ultrasound transmission is pulsed or continuous, and examination time.

Beneficial effects of heating such as pain relief, resolution of inflammatory infiltrates, and increase in blood flow are exploited in ultrasound therapy. Experimental animal studies in mice and guinea pigs have shown that continuous ultrasound with an intensity of more than 100 mW/cm^2 applied to the fetus for an uninterrupted period of more than 10 minutes may affect the fetus significantly. In medical diagnostic use of

ultrasound, the heating effect is normally well below a temperature rise that would be considered potentially dangerous (e.g. 1–2° C) [11,12].

3.8.2 Mechanical Effects of Ultrasound

Mechanical effects are due to cavitation or particulate streaming which cause violent movement of the particles of the medium. Cavitation requires small, stable gas bubbles to be present in the tissues, and involves implosion (the collapse) of the bubbles caused by the ultrasound. The sudden collapse results in mechanical damage and possible formation of free radicals. Experimentally, both macroscopic damage (rupture of blood vessels and cells) and microscopic damage (e.g. to chromosomes) have been found, and when gas bubbles of the appropriate size (in the order of microns or smaller) are present, mechanical damage may occur even at the low ultrasound intensities delivered by diagnostic ultrasound scanners. However, the intensity threshold for cavitation in man is much higher than that obtainable by commercial instruments (approximately 1 kW/cm²), and even though thermal and mechanical effects may act synergistically, no confirmed bioeffects in patients (or operators) have ever been observed [12].

3.8.3 Cavitation

Acoustic cavitation is defined as sonically induced activity of gas filled cavities. It is either inertial or non *inertial*.

3.9 The American Institute of Ultrasound in Medicine's Statement

The American Institute of Ultrasound in Medicine's statement on the Safety of Clinical Ultrasound released in 1982 and in 1997 states that widespread clinical use over 25 years has not established any adverse effect arising from exposure to diagnostic ultrasound [12].

No confirmed biological effects on patients or instrument operators caused by exposure at intensities typical of present diagnostic ultrasound instruments have ever been reported. Although the possibility exists that such biological effects may be identified in the future, current data indicate that the benefits to patients of the prudent use of diagnostic ultrasound outweigh the risks, if any that may be present.

More recent studies are of greater value than older publications because they relate to the influence of modern equipment and scanning techniques that are well known to be associated with power output levels significantly greater than those used previously.

3.10 Summary of Epidemiological Evidence

There remains no firm epidemiological evidence of hazard. Available data in the literature do not indicate any specific risks of physical damage arising from the use of ultrasound. Cavitation can be produced in vitro by ultrasound but there is no evidence that it can cause human damage in vivo. Thermal effects are perhaps those of greatest concern and precautions must ensure that significant temperature rises are avoided in practice [12,13]. The greatest risks arise from the use of ultrasound by inadequately trained staff, often working in relative isolation and using poor equipment.

3.11 Conclusions

The World Federation for Ultrasound in Medicine and Biology's conclusions on Thresholds for Non-thermal Bio-effects best describes the safety issues to be considered during ultrasound usage. For a given tissue, the threshold of known potentially adverse biological effects depends strongly on the insitu acoustic pressure amplitude at a given frequency, but only weakly on other acoustic parameters such as the pulse duration and repetition rate the exposed volume of tissue and the total exposure time.

Thresholds for confirmed non-thermally induced biological effects in mammalian tissues in the diagnostic frequency range of 2-10 MHz are above approximately Mpa for tissues that are known to contain gas bodies, such as the lung and the intestine. For tissues not known to contain such gas bodies, thresholds can be assumed to be greater.

A temperature elevation of less than 1.5°C is considered to present no hazard to human or animal tissue, including a human embryo or fetus, even if maintained indefinitely. Temperature elevations in excess of this may cause harm, depending on the time for which they are maintained. A temperature elevation of 4°C, maintained for 5 minutes or more, is considered to be potentially hazardous to a fetus or embryo.

CHAPTER 4

SYSTEM OPERATION AND TESTING

4.1 Introduction

Over the last few chapters the propagation properties have been described in detail. This chapter will discuss the operation of the system developed. Since the study is comparable to a pilot study, and the testing is limited to the validation of the Hardware and Software. This chapter begins by describing the details previously presented in previous chapters.

4.2 Ultrasound Propagation and Reflection Properties

- Velocity of sound in “soft tissue” is nearly constant = 1500 m/sec.
- Velocity of sound in bone and air differ greatly from soft tissue.
- $\text{Velocity} = \text{Frequency} \times \text{Wavelength}$
- $\text{Wavelength} = \text{Velocity}/\text{Frequency}$
- Acoustic energy is reflected at interfaces between tissues with differing acoustic impedances (Z).
- Acoustic impedance is equal to the product of velocity of sound (v) and physical density (ρ).
- For soft-tissue/air, soft-tissue/bone and bone/air interfaces, almost total reflection occurs.
- Velocity (V) decreases during transmission of an ultrasonic wave.
- Frequency is unchanged during propagation.
- Wavelength therefore will change as the velocity of the medium changes.

- Sound “bends” at interfaces between tissues with different velocities of sound.
- Intensity of ultrasound decreases during propagation, measured in dB/cm.

4.3 Testing

As discussed in the previous chapters, eight transducers were proposed to be used to determine the ultrasound propagation properties. As the data collection depends on the reliability of these eight transducers, the driving circuitry, which includes the Software, and Hardware system components, it is essential to perform appropriate testing on both these systems before data collection can be initiated.

4.3.1 Transducers

Initially eight transducers ranging from a frequency of 30 KHz to 300 KHz (with individual frequencies of 30 KHz, 41 KHz, 50 KHz, 75 KHz, 130 KHz, 200 KHz, 225 KHz and 300 KHz) are used to understand the characteristics of ultrasound in this study. The reliability of these transducers should be tested to obtain reliable and accurate data. Frequency is the most important parameter in defining a transducer, thus it is an important parameter to test.

In order to perform the required testing of the transducers, sample data were collected without fog in the testing room. The collected data were plotted against a timeline and calculations were done to obtain the frequency received by the transducers. The following calculations were performed to test the reliability of transducer’s frequency. Frequency of any given transducer is defined as the inverse of the time period.

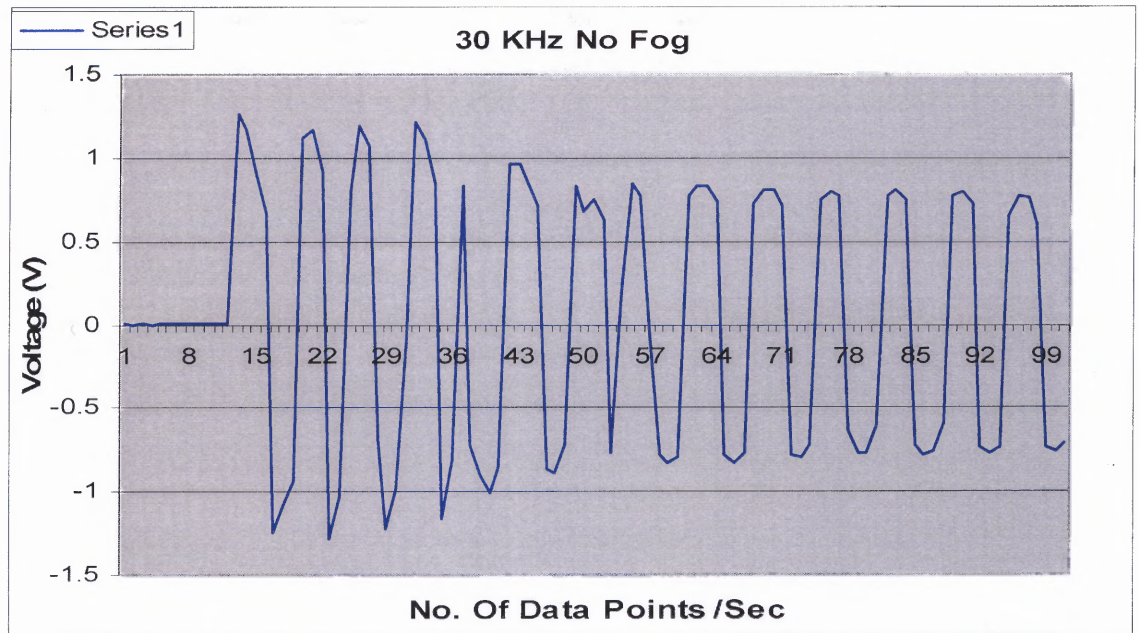

Figure 4.1 Magnified graph showing the number of data points (Vs) voltage level of a 30 KHz transducer

$$\text{Frequency} = \frac{1}{T}$$

Here T is the time period and is given by the fraction between the Number of data points present in one cycle and the total number of data points collected in one second.

$$T = \frac{\text{Number of Data Points / Cycle}}{\text{Number of Data Points / Sec}}$$

The number of data points present in one cycle can be calculated from the graphs shown above for each transducer. The above calculations were made on the data collected and the frequency of the transducers was found to be approximately around their manufacturer specified range of operation.

The graph shown above is that of a 30 KHz transducer taken under conditions of no fog to ensure baseline data. According to the calculations stated above, frequency will be the inverse of the time period. In order to find the time period the knowledge of the

total number of data points in a given cycle is required. For the graph shown above the number of data points/cycle = Number of data points in 10 cycles / number of cycles.

$$= 63 \text{ (approx.)} / 10$$

$$= 6.3 \text{ points / cycle}$$

$$T = \frac{\text{Number of Data Points / Cycle}}{\text{Number of Data Points / Sec}}$$

Therefore the time period will be = $6.3 * .000005 = 0.0000315 \text{ sec.}$

Frequency will be then = $1/T = 1/0.0000315 = 31,746 \text{ Hz.}$

Thus, the operation of the transducer and the driving circuitry is tested and verified. Similar calculations were performed on the other three transducers and their individual frequencies were found to be in the operating frequency specified by the manufacturer.

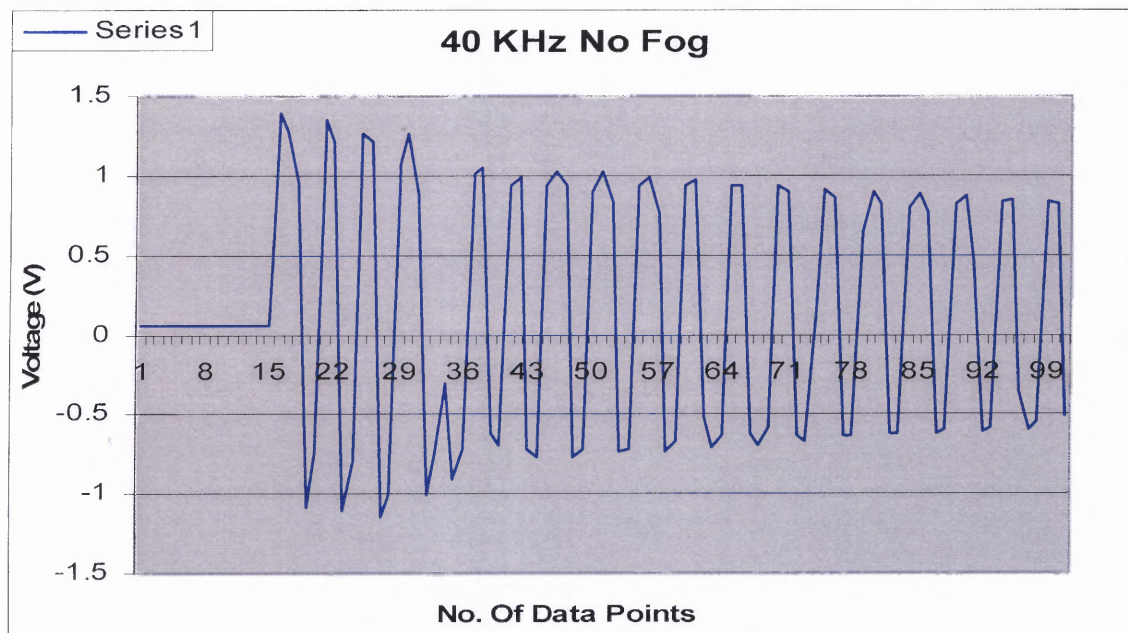

Figure 4.2 Number of data points (Vs) voltage level of a 40 KHz transducer

For the graph shown above the number of data points/cycle = Number of data points in
10 cycles / 10 = **4.8 Points / cycle**

$$T = \frac{\text{Number of Data Points / Cycle}}{\text{Number of Data Points / Sec}}$$

Therefore the time period will be = $4.8 * .000005 = 0.000024s$

Frequency will be then = $1/T = 1/0.000024 = 41666 \text{ Hz}$. Similar calculations were performed on the other two transducers and their frequencies were found to be 50 KHz and 75KHz with a tolerance of (1-2%) respectively.

4.3.2 Testing of Driving Circuitry

The transducers were driven by both the hardware as well as the software system. In order to ensure reliability, both the systems were tested. The procedure explained above satisfies the testing of frequency by collecting data through the transducers. This testing integrates both the software and the hardware system, leaving the driving circuitry to be tested.

A software program was coded to trigger transducers alternatively and is presented in the Appendix. The original data collection was done by triggering the eight transducers in an alternative sequence at different distances and different fog concentrations. The test program checked the proper triggering of the transducers by controlling the driving circuitry. If the driving circuitry cannot be driven sequentially, physical intervention between the switching of the transducers would be required. The following is the sequence of voltage values applied to the driving circuitry to drive eight different transducers.

Table 4.3 Digital Inputs

| Port 1 | Port 1 | Port 1 |
|--------|--------|--------|
| 0 | 0 | 0 |
| 0 | 0 | 1 |
| 0 | 1 | 0 |
| 0 | 1 | 1 |
| 1 | 0 | 0 |
| 1 | 0 | 1 |
| 1 | 1 | 0 |
| 1 | 1 | 1 |

4.4 Materials and Methods

The system consists of The Fog Chamber, the Transducers, the Corresponding Target, the Synthetic Fog Machine, the Software System and the Hardware Trigger.

4.4.1 Fog Chamber

The fog chamber is an important part in the data collection. Before data acquisition, the Fog chamber needed to be equipped to facilitate the housing of the transducers, the synthetic fog machine and the target. The fog chamber needed to be sealed so that it did not have the fog dissipate. Another important requirement of the chamber also required it to be sealed with foam serving as signal absorbent which will absorb the reflected signals namely ultrasound and audible sound so that the signals do not bounce off the surface of the walls of the chamber and cause an artifact in the acquired signal.

4.4.2 Vents

Other than the requirements discussed above, being a sealed room, the chamber should be provided with proper ventilation so as to facilitate a proper outlet for the fog out of the chamber once data acquisition was completed. Two powerful blowers are provided to

4.4.3 Target and Position of Target

The transducers emit ultrasound waves, which in the presence of a perpendicular target to the path of the waves will send echoes back to the transceiver. In order to set up a target, the following points were considered. The height and position of the target was extremely critical. If the waves are at an angle to the target only part of the reflected waves reach the transceiver.

The target material was required to be non-absorbent so that all the incident waves are reflected back to the transceiver. The actual process of data collection was done with the fog in the fog chamber and therefore the mobility of the target was extremely critical.

The target was placed at different distances from the transducers so that data acquisition could be made possible. Therefore, the target should move easily around the fog room to different fixed distances without the experimenter entering the fog chamber. This can be achieved by connecting the stand in which target is mounted to a pipe at the bottom so that the pipe can be pulled from outside the fog chamber. This will facilitate the positioning of the target at different points in the chamber and thereby decrease the time taken to collect data.

The time taken for data acquisition is critical because the fog level is expected to decrease or slowly disintegrate over a period of time and the density on the pathway between the transducers and the target should be the same for all the different distances for which the data was acquired.

4.4.4 Position of Synthetic Fog Machine

The synthetic fog machine is provided with one nozzle for fog dissipation and it is critical that synthetic fog to spread evenly across the chamber in order to maintain a homogenous density across the transducer to the target. The positioning of the synthetic fog machine must be neither too close nor too far away from the target since this will lead to improper fog dissipation across the room. The synthetic fog machine should be positioned equidistant from the target and the transducers every time the data is acquired so that the density remains constant over data acquisition.

4.4.5 Transducers

The eight transducers are housed in a two shelves with four transducers in each of the wooden shelves. The transducers while acquiring data should be positioned exactly parallel to the target so that the ultrasonic waves will be perpendicular to the target material. Also the transducers were kept far apart in order to ensure that adjacent transducers don't reflect ultrasonic waves and cause noise in the received signal.

4.4.6 Synthetic fog Machine

The synthetic fog machine was positioned at equidistant from the target and the transducers in order to obtain constant density over the range of distances used for data acquisition. Also the synthetic fog machine was placed such that the target can be moved around the fog chamber without disturbances in the path of the ultrasound waves.

4.4.7 Software and Hardware System

Both the software and the hardware system were housed outside the fog chamber. This enables control of the transducers and data acquisition without interfering with the fog chamber and the target. The hardware system consisting of the relays and the interface board needed to be close to the software system in order to control the hardware.

4.5 Data Collection and Analysis

The data collection process was the final step in concluding the study. The primary objective of the study was to collect data pertaining to the intensity of ultrasound at different target distances and different fog densities. This will provide enough information to suggest the influence of an environment filled with fog on the physical properties of ultrasound, namely the intensity.

The data were collected under two different standards. The first set of data consists of the baseline data and the second set contains the actual data at different densities of fog and different target distances. Baseline data containing the characteristic information in the absence of fog and fog data that corresponds to the data collected with the room filled with different levels of fog density. Data collection was performed at a set temperature as temperature is found to affect the performance of the ultrasonic transducers.

4.5.1 Protocol for Data Acquisition:

- The system developed as previously described, has both software and hardware components both integrated to acquire and store data. The protocol for data acquisition is explained as follows:

- The synthetic fog machine is set to warm up (arm) by the software program. The optimum temperature is (345 – 350 °C).
- Once the synthetic fog machine reaches the optimum temperature, a digital signal is sent to the fog interface. The fog interface consists of a relay which closes when energized. From the fog interface the digital signal is relayed to the software system, which turns ON the fog machine for the required period of time.
- The fog chamber was filled with fog for the required time period. The transducers were triggered sequentially from 30 KHz up to 300 KHz. Each transducer is triggered to acquire data for one second, which is the sampling time. After acquiring the data from all the eight transducers, the position of the target is changed to the next level farther from the transducer.
- Data collection is done from 1ft to 8ft for each transducer at density levels of fog from 5 seconds of fog to 25 seconds of fog.

4.5.2 Data Acquisition

During the process of baseline data and the fog data collection, the following parameters such as the sampling rate, the sampling frequency and the temperature are kept constant in order to enable the process of data collection.

4.5.3 Sampling Rate:

The baseline data was initially obtained for all the eight transducers. With the sampling rate set at 200,000 samples / sec according to sampling theory, was not adequate to sample signals of higher frequencies such as 120KHz, 200KHz, 225KHz and 300KHz.

4.5.4 Sampling frequency

Signals must be filtered prior to sampling. Theoretically, the maximum frequency that can be represented is half the sampling frequency. When sampling an analog signal, the sampling frequency must be greater than twice the highest frequency component of the analog signal to be able to reconstruct the original signal from the sampled version.

Also, during the process of data collection the sampling rate in LABVIEW was increased but the resultant values were not satisfactory. The data acquisition card from LabVIEW used in this study was not able to handle data sampling higher than 300,000 scans / sec. A DAC card of higher sampling capacity can be used to measure and process higher frequency signals. Therefore, the data acquired suffered from under sampling. Those samples were not taken for analysis. Data collection was then reduced to transducers operating at 30KHz, 41KHz, 50 KHz and 75 KHz.

4.5.5 Temperature

The temperature dependence of the power received by an ultrasound transducer from the backscatter of an interrogating pulse is dependent on how certain ultrasonic characteristics (speed of sound, attenuation and backscatter coefficient) change with temperature. A theoretical parametric analysis showed that the temperature dependence of the backscatter coefficient dominates the variation of the received power with temperature. According to this analysis the power received by the transducer could either increase or decrease depending on the type of tissue and the in homogeneities within the medium of propagation. The change in energy of these scatterers can increase or decrease with temperature and is mostly monotonic. Typically we have seen a change of between 5 and 15 dB in backscattered energy over the temperature range of 37–50°C.

4.5.6 Software system

The software system controlled the acquisition of data from the transducers and was also responsible for the storage of data. Data were acquired from the transducers by sequential triggering of the transducers along with the synthetic fog machine. The acquired data were divided into two sections, the transmitted pulse and the received echoes. The area of primary interest is to compare the voltage level of the received pulses with the corresponding levels of the transmitted pulses. This shows the effect of the fog environment on the energy level of the acquired signal.

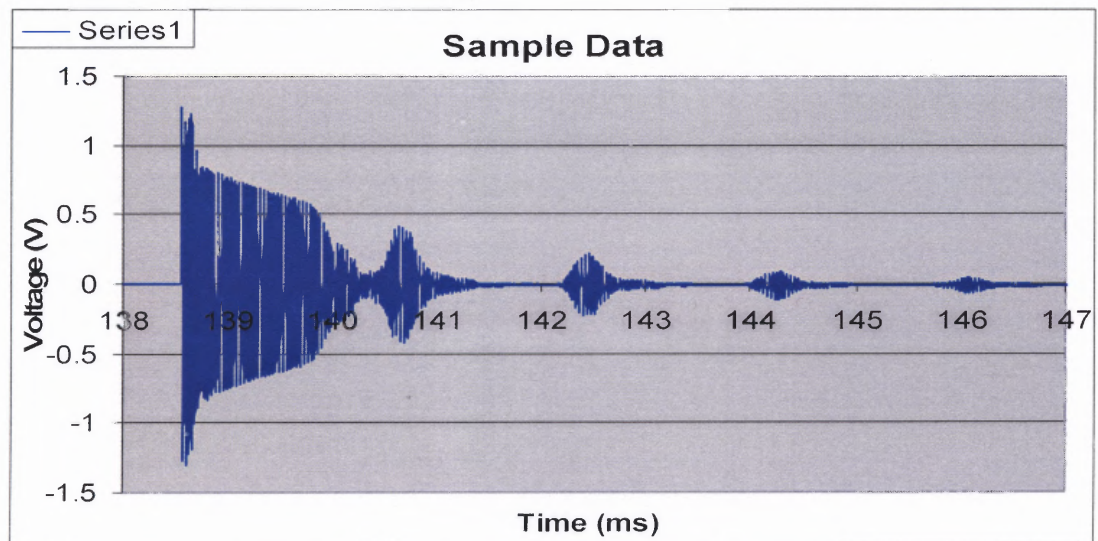

Figure 4.3 Graph showing the transmitted and received pulses

The echoes describe the properties of the environment. The reception of the echoes from the target is achieved by the transducers. The transducers then convert the received mechanical echoes or mechanical waves into the corresponding voltage level. The acquired voltage signal is in turn fed into the data acquisition and processing system. With the sampling rate set to 200,000/sec, each transducer is run for one second to collect

to collect 200,000 points of data. A typical graph containing the transmitted and the received pulses is shown in the figure above.

4.5.7 Hardware System

The hardware system was comprised of the transceiver driving circuitry and the alternating relays used to switch between the individual transducers. The synthetic fog machine with the interface and the transducers comprise of the hardware system. The hardware system has been discussed in detail in the previous chapters. The following shows the schematic of the hardware system.

4.6 Results

The following are the baseline data for 30 KHz, 41 KHz, 50 KHz and 75 KHz transducers at 1ft, 3ft and 5ft. The acquired raw data were analyzed to find the peaks in the transmitted and the received pulses for different distances and different fog densities. Individual transducers are triggered to obtain ultrasound in the presence and absence of fog and the voltage is found to decrease in the presence of a fog. The following graphs explain this.

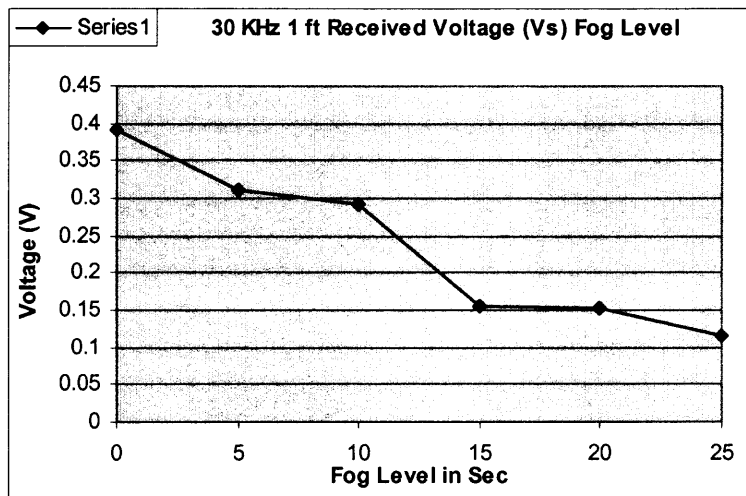

Figure 4.4 Voltage (Vs) Fog level for 30 KHz transducer at 1ft distance

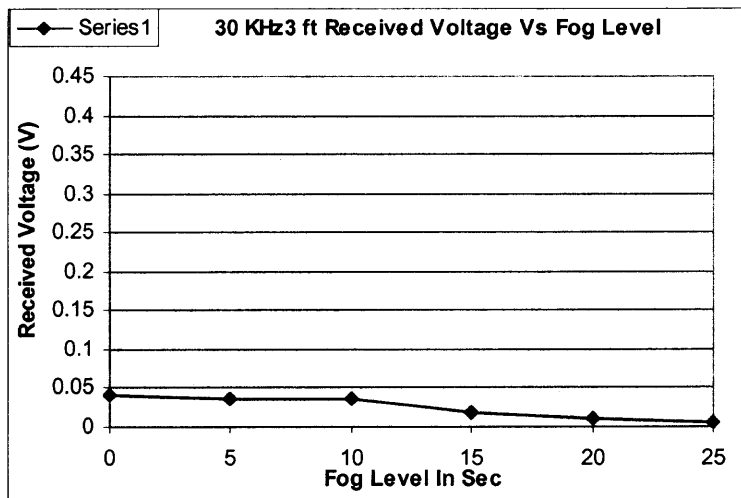

Figure 4.5 Voltage (Vs) Fog level for 30 KHz transducer at 3ft distance

As that data were being collected and graphs plotted it was observed that the received echoes from the 75 KHz transducer were not clearly distinguishable. Therefore, the 75KHz transducer was removed from the study leaving only three transducers - the 30KHz, 41KHz and 50 KHz to collect data from. Also, of these transducers only the 30 KHz transducer showed sharp peaks of received pulses at 3ft when compared to others and those data are included. This limits us with minimum data for analysis.

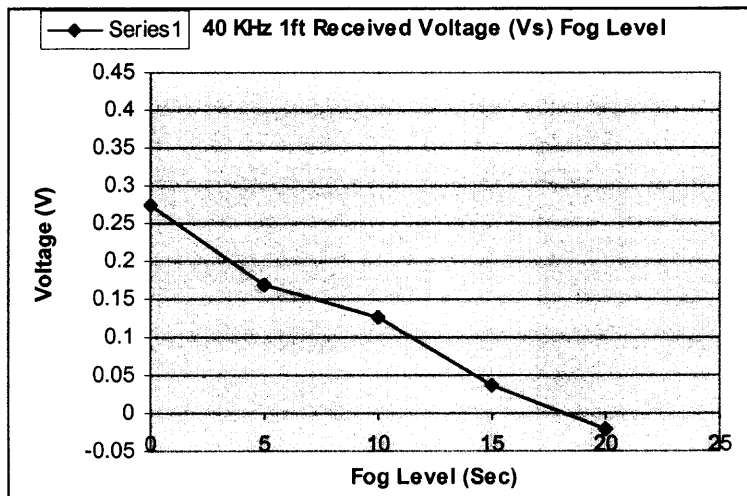

Figure 4.6 Voltage (Vs) Fog level for 40 KHz transducer at 1ft distance

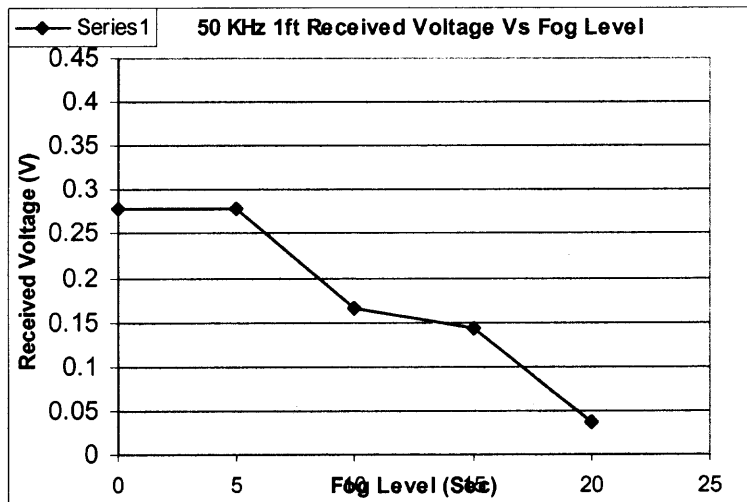

Figure 4.7 Voltage (Vs) Fog level for 40 KHz transducer at 3ft distance

4.7 Conclusion

The pilot study has clearly shown results that indicate that the presence of fog in the environment has decreased the intensity of the reflected pulses reaching the transceiver. The physical parameters of the transducer namely ultrasound intensity are studied using four transducers. Understanding of the physical properties of ultrasound energy in the fog environment is not only restricted to the intensity of ultrasound and other physical properties namely the frequency and the decibel level are not studied in this study. But with the data collected on the intensity of the ultrasound level it is understandable that the presence of fog in the environment acts less in favor of the transmission of the waves across the environment. Since no previous study has determined an actual testing method or data to study ultrasonic energy in fog environment the data collected in this study could not be compared to existing literature. That makes this study unique in itself and provides more areas to explore.

Chapter 5

CONCLUSIONS

5.1 Introduction

The ultimate goal of this thesis study was to determine the physical properties of ultrasound in a fog filled environment. This chapter will summarize the goal behind the study, the steps followed to achieve the goal, the level of accomplishment, some suggested improvements and finally considerations for future work.

Any scientific study should be designed and structured considering the final output and the materials needed to achieve the desired output. Therefore, the first topic to be discussed in this chapter will be the structure of the study. This includes the goal of the study and the materials required for the accomplishment of the final output.

5.2 Design and Implementation

To design a scientific study, the goal and the rationale behind the goal must be stated before initiating the study. According to previous studies, ultrasound is known to travel in various mediums with different velocities depending on the density and the elasticity of the medium chosen. Such studies state that the propagation of ultrasound is considerably faster in liquid and solid medium than in air. Little or no study has been done in an environment filled with fog.

A considerable difference between the other mediums and fog is that a fog is a complex medium called aerosol. An aerosol can be defined as a medium, which is a combination of two mediums in itself, liquid particles suspended in air. Particles of matter, solid or liquid, larger than a molecule but small enough to remain suspended in the atmosphere (up to 100 μ m diameter). There are aerosols of liquid droplets (e.g., fog,

cloud, drizzle, mist, rain, spray) and aerosols of solid particles (e.g., fume and dust). Natural origins include salt particles from sea spray and clay particles as a result of weathering of rocks.

The choice of fog for the testing environment is that it is a combination of water and air combining the best of both the medium. Since, very less research work has been done with ultrasound in a fog filled environment this study can be considered as a pilot study. The reason for choosing fog has another important reason. Fog, being a combination of both gaseous and liquid medium theoretically provides more probability of improving the propagation of ultrasound.

5.3 Software and Hardware Considerations

Once the goal is understood, the next step was to design appropriate software and hardware systems that will then perform the necessary measurements. The requirements of the hardware system were to generate the ultrasound signals and alternate between the transducers so as to enable to measurement of the received signals from all the eight transducers. The software system controls the hardware system and collects and stores the data for further analysis.

Ultrasound is currently considered to be a safe, non-invasive, accurate and cost-effective investigation of the fetus. A ultrasonic microphone is pressed against the skin surface being scanned, using surface gel to improve the contact. If we can improve the propagation of ultrasound by subjecting its transmission through a fog filled medium, which can replace the gel between the hydrophone and the skin, non contact ultrasonic scan can be made possible.

5.3.1 Software System

The software system developed performs the following functions :

- The synthetic fog program controls the arming and triggering of the synthetic fog machine. Synthetic fog device has two states of operation namely arm and trigger. The synthetic fog program controls the fog machine with the help of digital signals communicated through the LabVIEW interface card to the synthetic fog machine.
- The second program controls the triggering of transducers through a hardware interface board. The hardware interface board acts as a switch to switch between the individual transducers. The developed program should be able to provide “make before break” switching. This refers to turning off the first transducer before turning on the consecutive one. Any combined triggering will result in the production of noise in the signal output which is undesirable. Time delay should be provided between the triggering of transducers. This is essential since the transducers tend to have residual echoes due to the vibration. Once turned OFF these echoes decay exponentially.

5.3.2 Hardware System

The hardware system consisted of the “Synthetic Fog” generator, the hardware switching interface and fog chamber accessories. The “Synthetic Fog” generator was used to produce fog particles of the size of 1-10 micron. The “Synthetic Fog” generator was chosen such that it was rugged, compact size, powerful enough to facilitate faster filling of the fog chamber. Also, the liquid recommended for usage in the Synthetic “Synthetic Fog” generator played a vital role in the choice of Synthetic “Synthetic Fog” generator. The

liquid should be of minimum harm to the personnel because of prolonged exposure. Also, the liquid used should be of easily disposable nature and user friendly. The hardware switching interface should produce less noise and allow maximum signal to pass through the relays. The interface should also be designed for handling higher frequencies. The fog chamber accessories consist of the target, the vents the foam padding for absorption.

5.4 Future Improvements

There are two ways of improving the developed system. The system developed consisted of two critical components – ultrasound and Synthetic Fog environment. Both components have profound effect on human physiology. Ultrasound has been used in biomedical applications on various fronts. As a diagnostic tool, ultrasound is used in imaging applications. Ultrasound is also widely used as a therapeutic tool in treatment. Fog and suspensions do not have therapeutic or diagnostic applications, but do seem to affect humans psychologically as well as physiologically. A future improvement of the developed system can be achieved either by improving either one of the two components individually or combining them to form a comprehensive system as was done in this study. Also, the existing developed system can be improvised technically by improving the Software as well as the Hardware system to yield better results. All the above three are discussed below.

5.4.1 Improvement in Research Area

Ultrasound, being a strong therapeutic and diagnostic tool, was studied in this research to understand its propagation properties. The very same propagation properties of ultrasound were found to be deteriorating in the presence of an artificially generated Fog

medium. It would be interesting as well as informative to the society of Ultrasound and Engineers if the reason behind the energy decay were analyzed.

There could be multiple reasons for the loss in ultrasound intensity such as, scattering of ultrasound waves due to the presence of random particles in the path of travel of ultrasound energy. Also, another possible reason for ultrasonic energy loss in a fog medium could be due to attenuation of waves by the suspended particles.

Fog as a medium of ultrasound was investigated in this study. The very same medium can be used to understand various other physiological as well as psychological concepts affecting humans. Fog being an obscurant can be studied to understand the effects on visibility, hearing as well as learning. Another interesting factor regarding fog noticed during the study was that the presence of fog in an environment tends to affect people psychologically. Fog medium tends affect people's state of mind different ways. A wide variety of feelings such as anxiety, social support, restlessness, mood disorders can be studied in the presence of an environment filled fog or in a combined environment of fog with other external stimuli. Also, studies can be initiated to understand the combined effects of ultrasound and fog on individuals.

5.4.2 Software Development

Ultrasound propagation properties include frequency, speed of propagation and intensity. The developed software program detects the signal received from the transducers and processes the signal to obtain real time signal information such as frequency and intensity. The program can be further developed to perform calculations of the difference between the transmitted and the received pulse in real time. In controlling the synthetic

fog machine, the software program be expanded to control the synthetic fog device to produce fog for predetermined time intervals.

5.4.3 Hardware Development

The developed hardware system controls the switching of the eight transducers in a sequential manner. In the technical side, developments can be made to study higher frequencies. Due to limitations in the sampling frequency of the software used, higher frequencies were not be able to be acquired.

A meaningful development will be to device a similar chamber for animal study. The presence of Fog and ultrasound can affect the psychological system of any living being and such a change of state can be studied in animals before studying human behavior.

Other than studying the physical properties, the developed software and hardware system can be used to study various behavioral studies. In humans, the presence of fog can affect one's state of mind in different ways. As a future development to the system developed it will be interesting to study the physiological properties of humans in such an environment. Though, such a development will differ from the primary goal of the system developed, such a study will be equally challenging and contributive to the society in itself.

5.5 Conclusion

The developed system consisting of hardware and software system integrated performs the following functions

- Triggering of transducers
- Arming and Triggering the Synthetic Fog Machine
- Control the sequential triggering of transducers.

Thus, the physical property namely the frequency of the ultrasonic transducers is stored and analyzed. Suggested future improvements include changes in Software and Hardware systems to enable easier and better data acquisition and extending theories of Ultrasound and Fog in human physiological and psychological studies.

APPENDIX A

FRONT PANEL AND BLOCK DIAGRAM OF FOG CONTROL PROGRAM

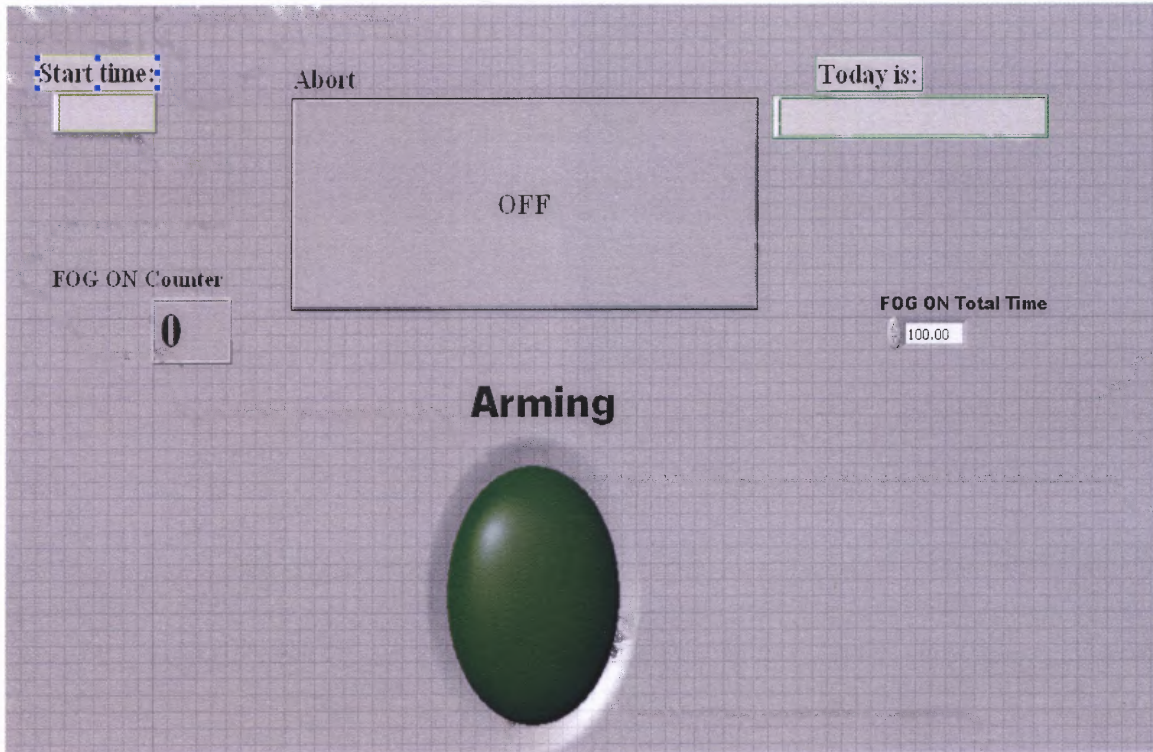

LabVIEW prompts the user to arm the “Synthetic Fog” device.

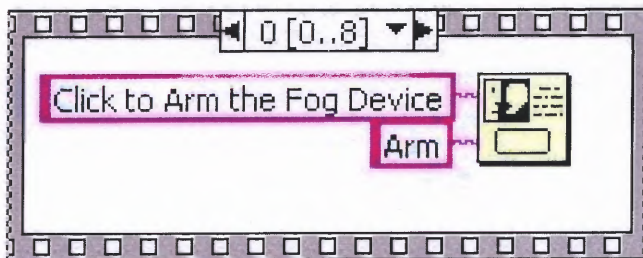

On user command, digital input is sent to the “Synthetic Fog” device to arm the device.

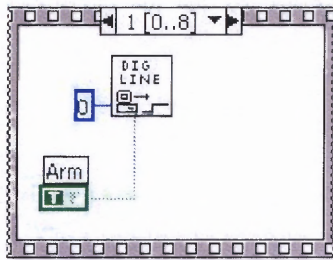

On arming the “Synthetic Fog” device, the temperature control is turned on and the fog fluid is heated. Ready signal sent to the software from “Synthetic Fog” device on the liquid reaching optimum temperature.

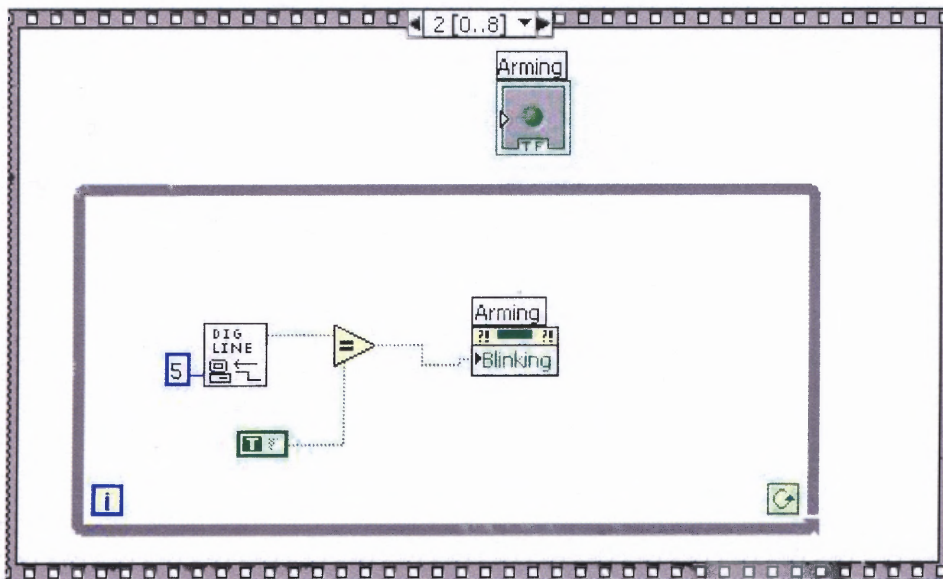

On receiving the ready signal from the “Synthetic Fog” device, the user is prompted by the software program to

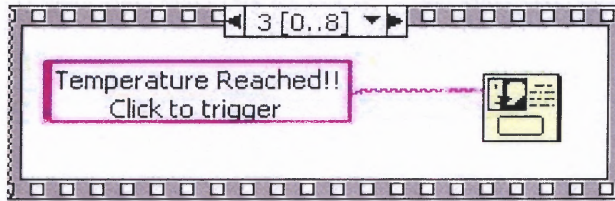

Time delay is introduced between the user triggering the software and the software triggering the “Synthetic Fog” device in order to ensure safety.

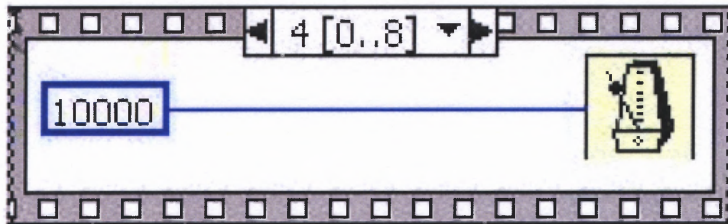

After the time delay, the “Synthetic Fog” device is triggered to fill the fog chamber with fog for the desired period of time.

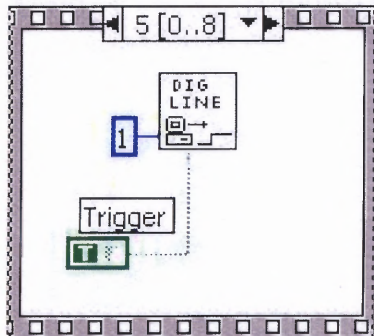

Digital time counter controls the fog on time period. Changing the variables in this frame of software, the fog on time period is increased or decreased correspondingly.

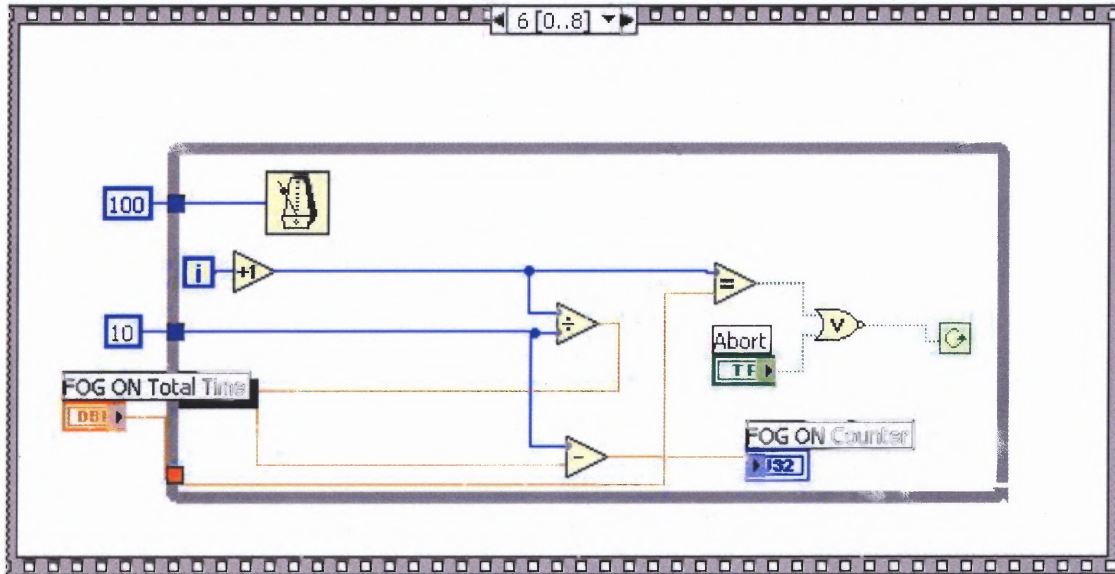

After the “Synthetic Fog” device completes filling the fog chamber for the desired time period, the device is turned off by turning off the trigger and the arm signal. In order to achieve that, 0V is applied to the arm and the trigger terminals from the software through digital input.

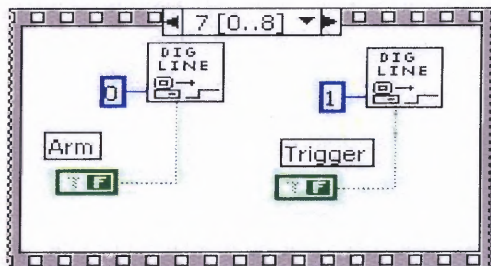

The protocol is completed by the experiment complete dialog box.

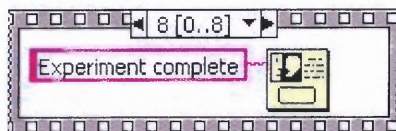

APPENDIX B

BLOCK DIAGRAM FOR SEQUENTIAL TRIGGERING OF TRANSDUCERS

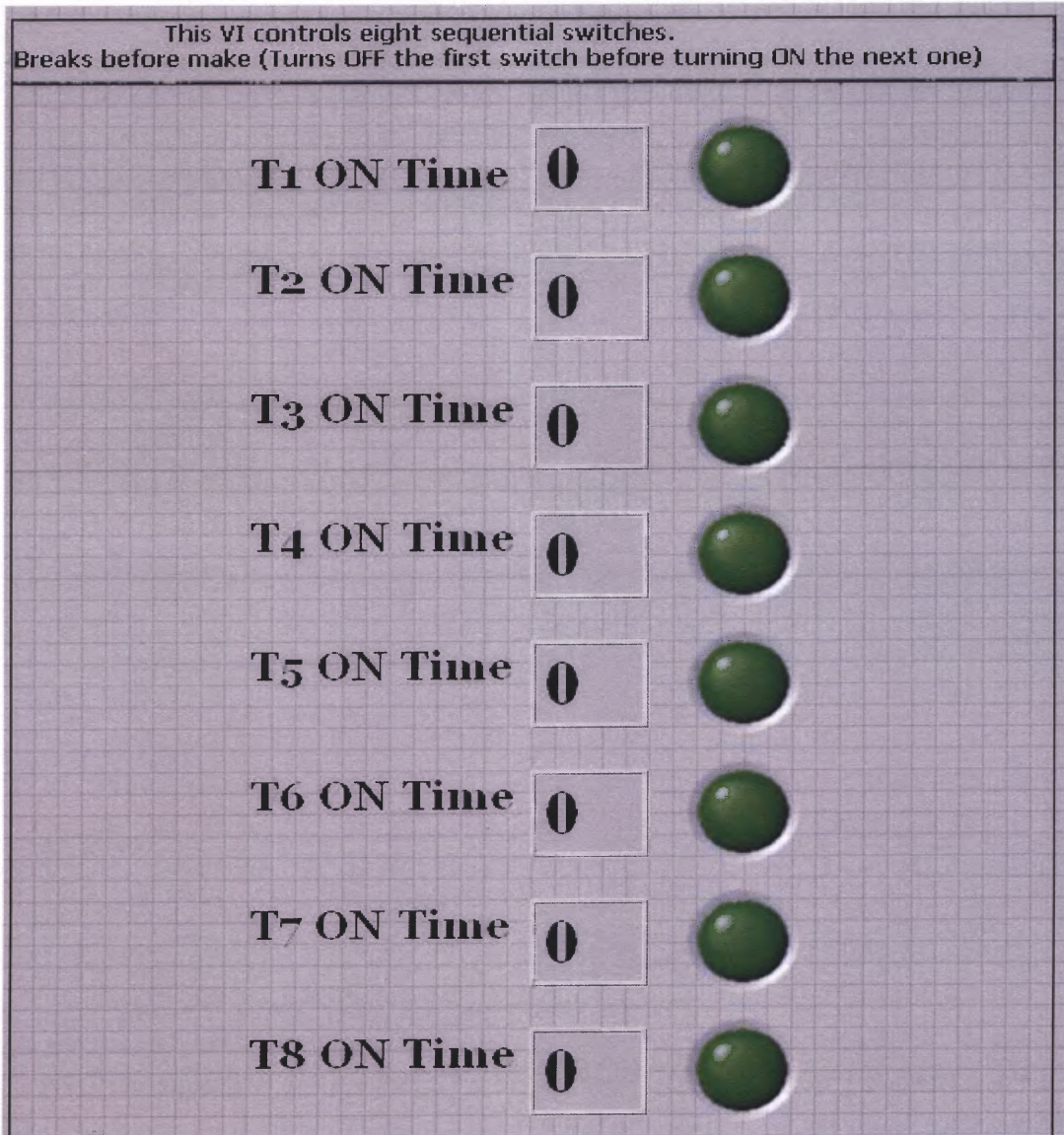

APPENDIX C

FRONT PANEL FOR SEQUENTIAL TRIGGERING OF TRANSDUCERS

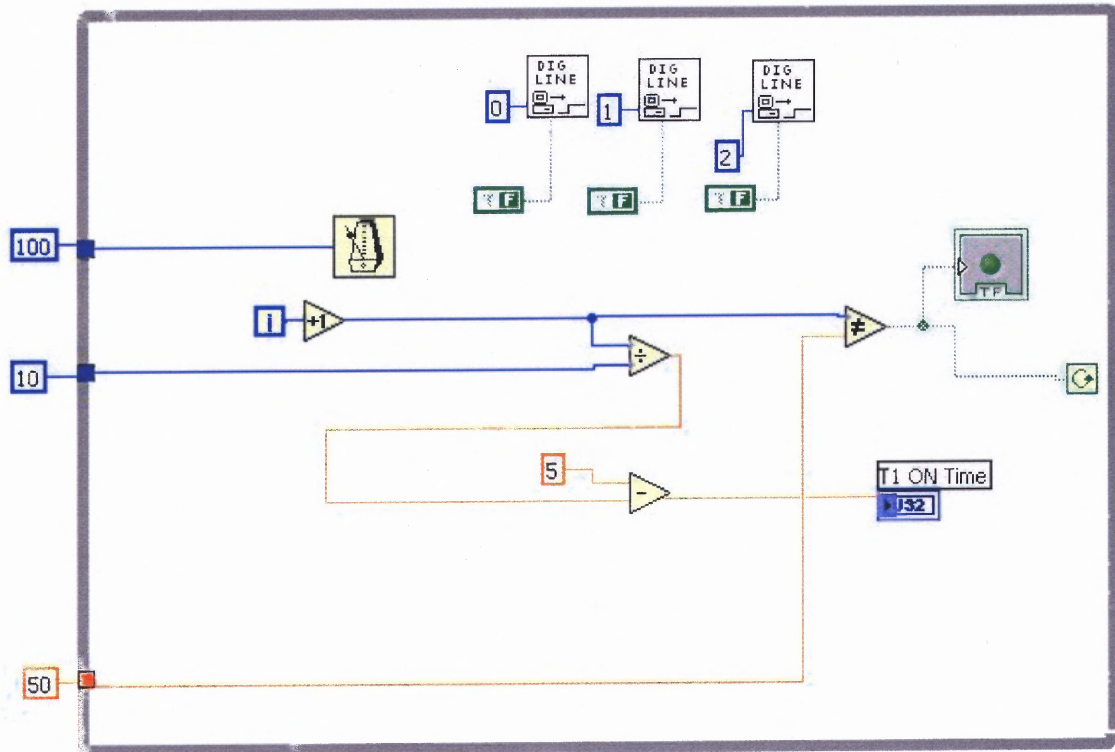

APPENDIX D

FRONT PANEL FOR ULTRASOUND SIGNAL PROCESSING

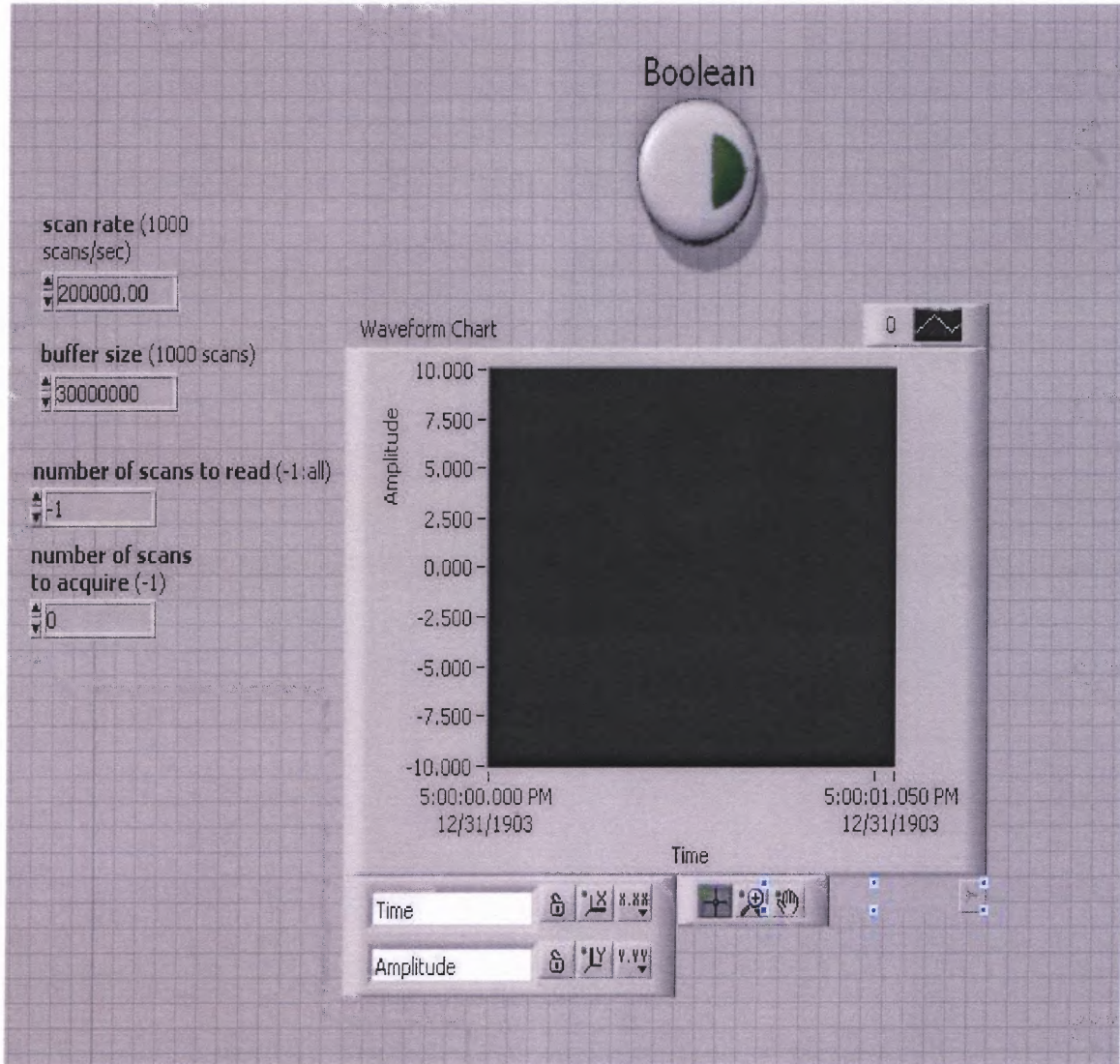

APPENDIX E

BLOCK DIAGRAM FOR ULTRASOUND SIGNAL PROCESSING

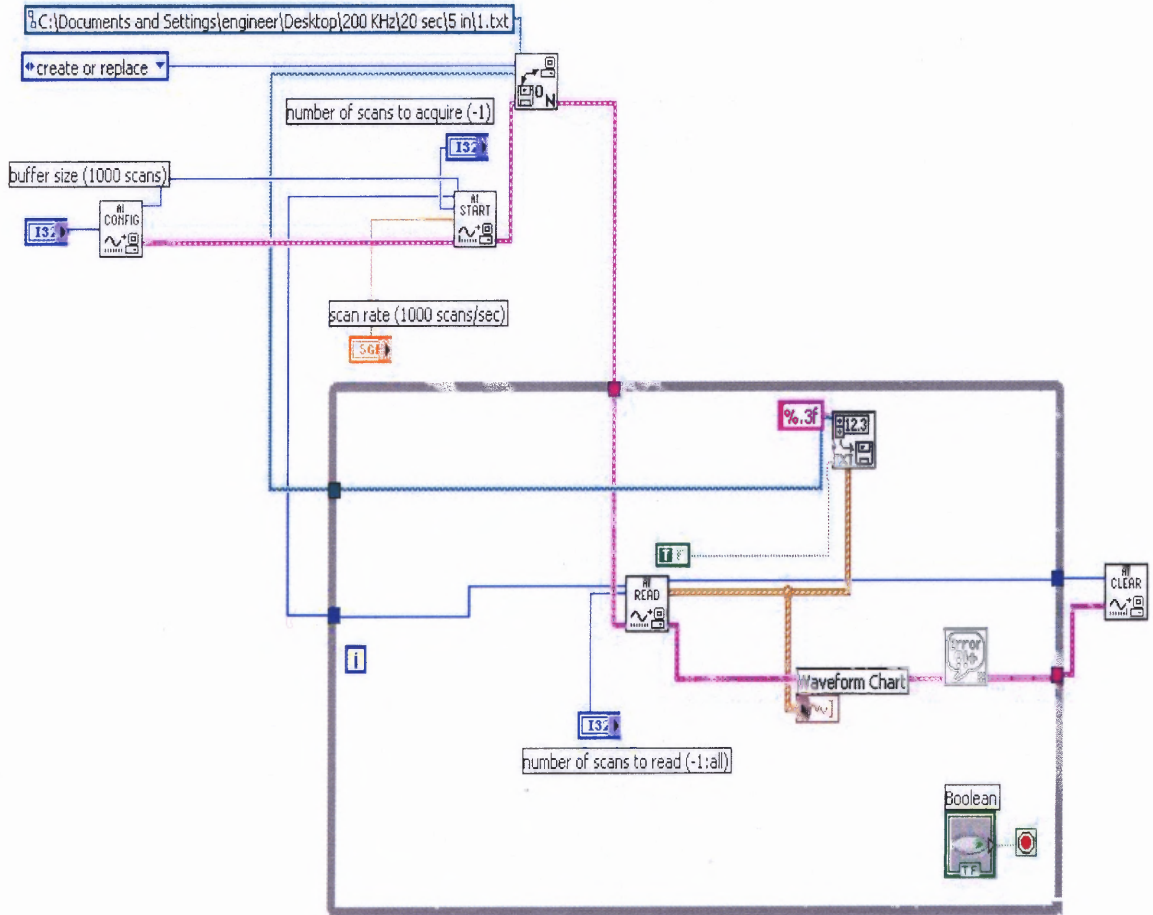

APPENDIX F

VOLTAGE (Vs) TIME GRAPHS FOR 30KHZ TRANSDUCER AT 1FT

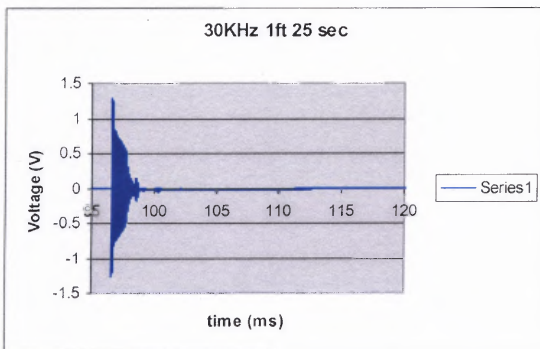
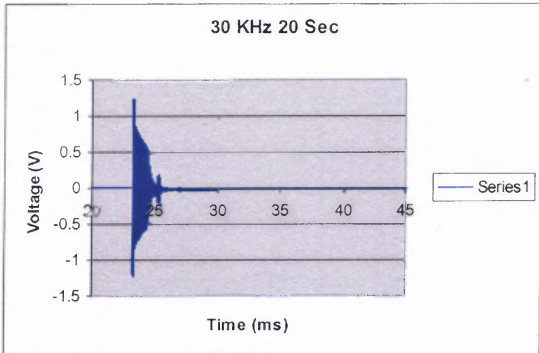
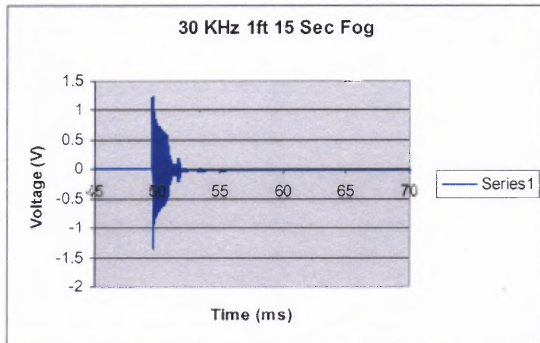
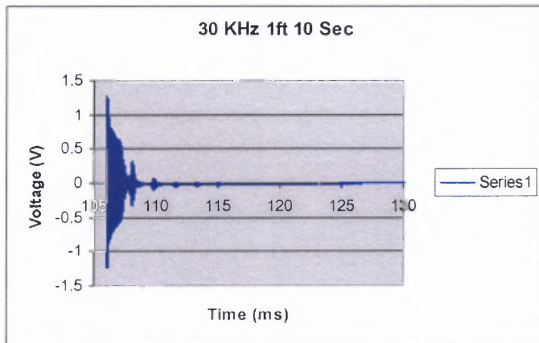
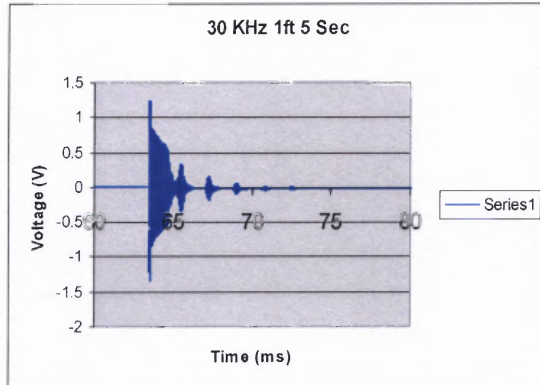
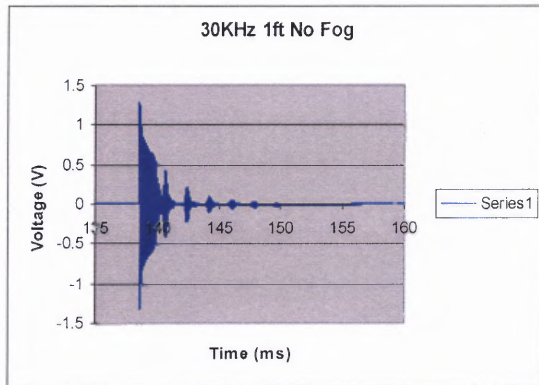

APPENDIX G

VOLTAGE (Vs) TIME GRAPHS FOR 40KHZ TRANSDUCER AT 1FT

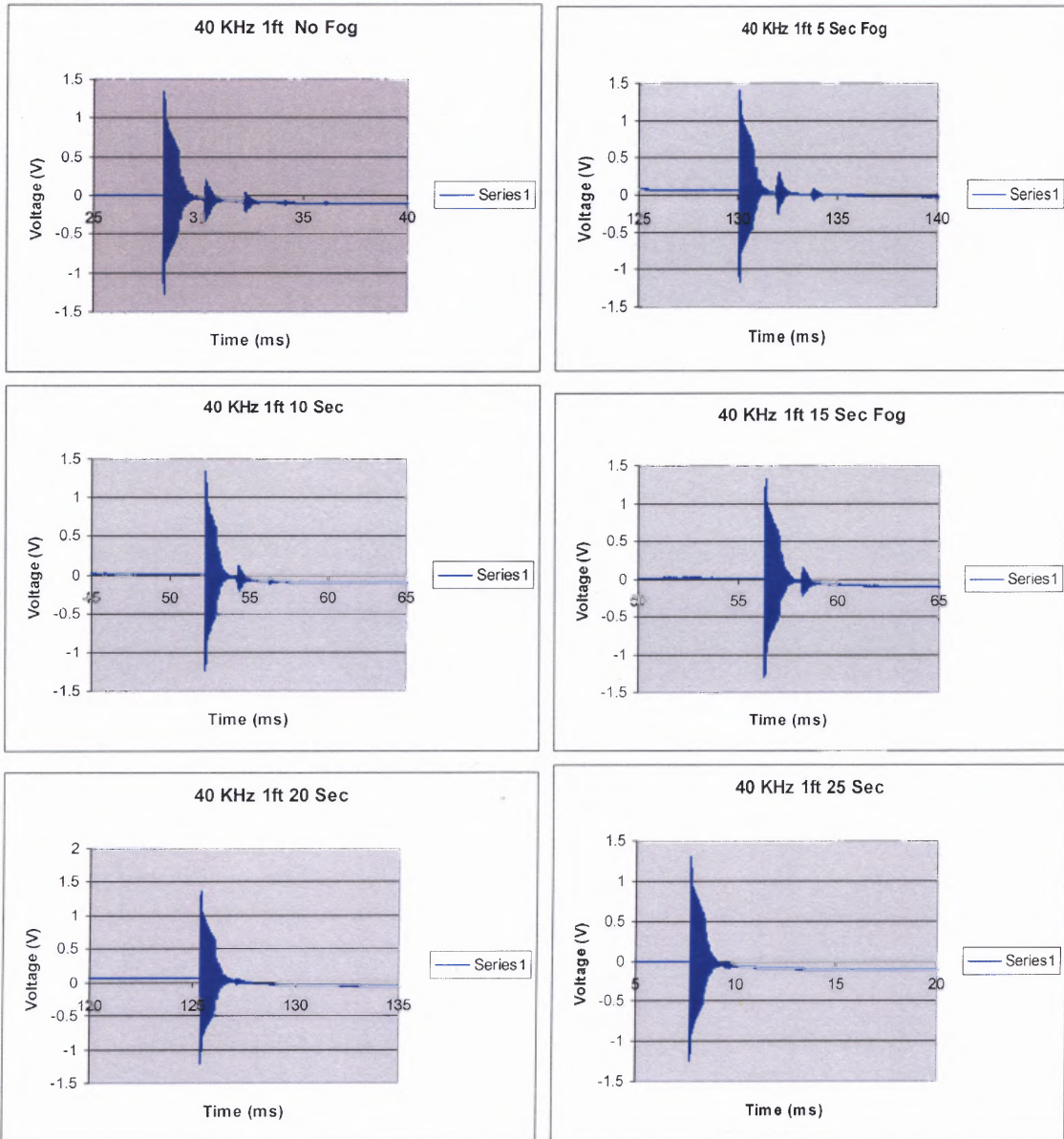

APPENDIX H

30 KHZ TRANSDUCER SPECIFICATIONS

Specifications

- Best Operating Frequency: 30kHz +/- 4%
- Min. Transmit Sensitivity: 105dB re 1 μ Pa/V at 1m at best transmit frequency
- Min. Receive Sensitivity: -155dB re 1V/ μ Pa at best receive frequency
- Min. Parallel Resistance: 700 Ω +/- 30%
- Minimum sensing range: 80cm*
- Maximum sensing range: 30m*
- Free (1kHz) Capacitance: 5700pF +/- 1000pF
- Beam width (-3dB full angle): 12° +/- 2°
- Maximum Driving Voltage: 3200 V_{pp} (2% duty cycle tone burst)
- Operating Temperature: -40°C to 90°C
- Weight: 800g
- Materials:
 - Housing: Glass filled polyester
 - Acoustic Window: Glass reinforced epoxy

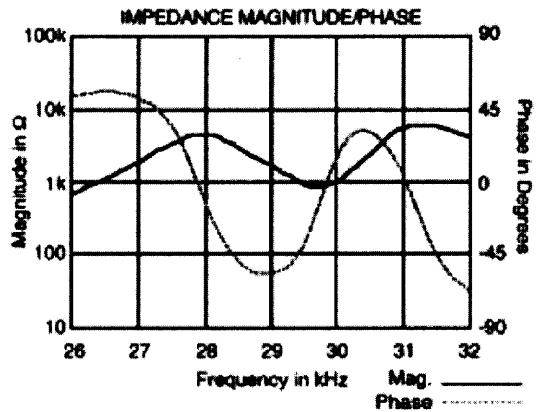
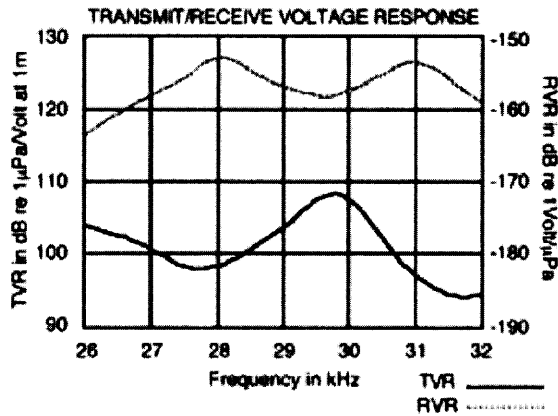
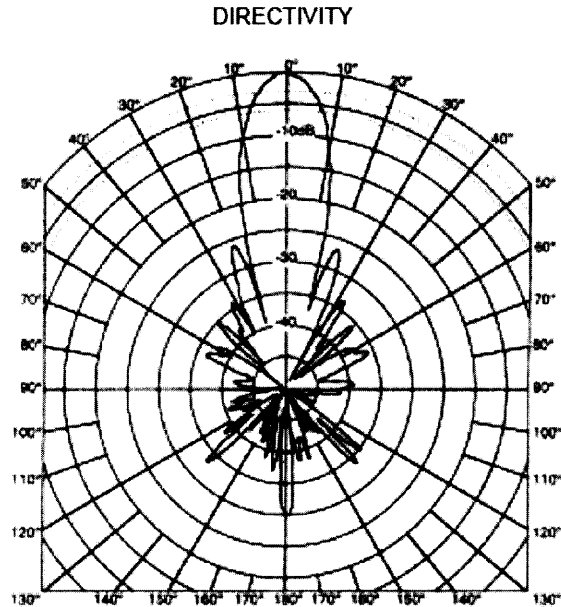

APPENDIX I

40 KHZ TRANSDUCER SPECIFICATIONS

Specifications

- Best Operating Frequency: 41kHz +/- 4%
- Min. Transmit Sensitivity: 110dB re 1 μ Pa/V at 1m at best transmit frequency
- Min. Receive Sensitivity: -160dB re 1V/ μ Pa at best receive frequency
- Min. Parallel Resistance: 150 Ω +/- 30%
- Minimum sensing range: 30cm*
- Maximum sensing range: 20m*
- Free (1kHz) Capacitance: 5000pF +/- 500pF
- Beamwidth (-3dB full angle): 14° +/- 2°
- Maximum Driving Voltage: 1800 V_{pp} (2% duty cycle tone burst)
- Operating Temperature: -40°C to 90°C
- Weight: 560 g
- Materials:
 - Housing: Glass filled polyester
 - Acoustic Window: Glass reinforced epoxy

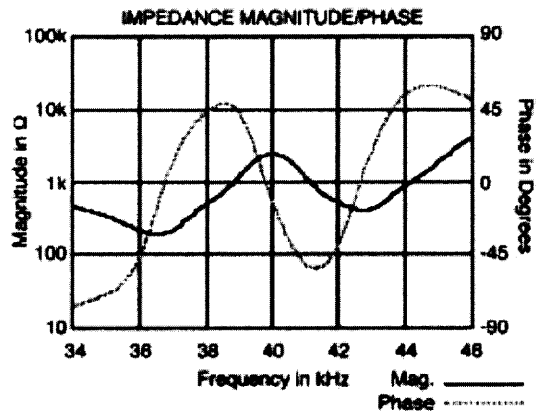
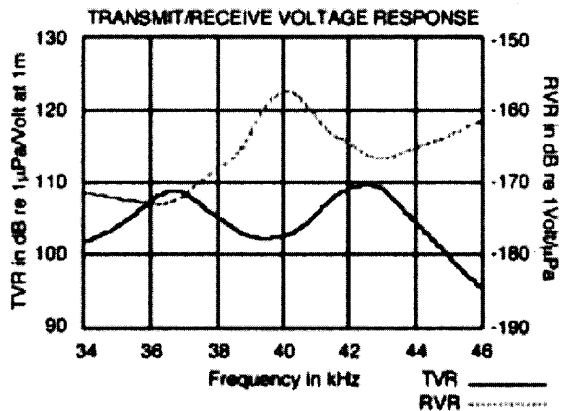
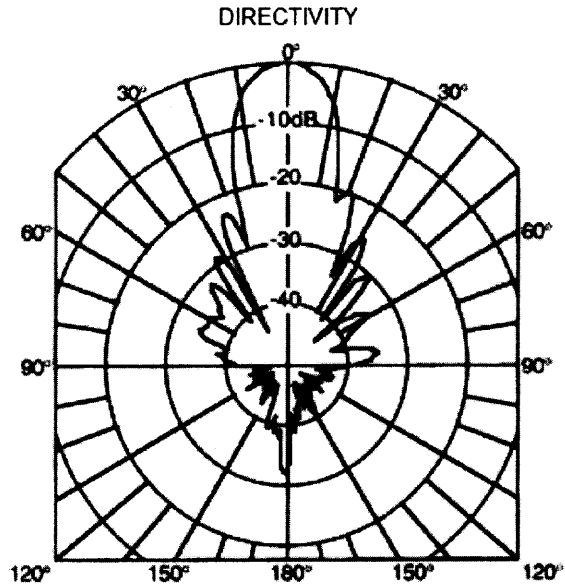

APPENDIX J

INVERTER SPECIFICATIONS

SN74S04 . . . D OR N PACKAGE logic diagram (positive logic)
(TOP VIEW)

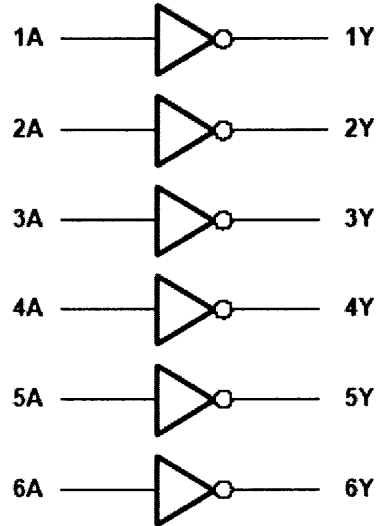
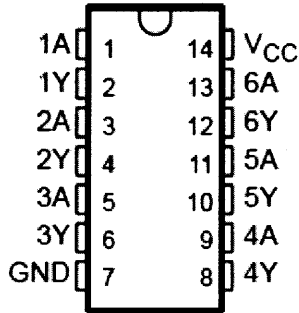

SN5404 . . . W PACKAGE
(TOP VIEW)

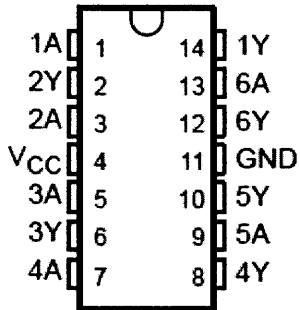

$$Y = \bar{A}$$

FUNCTION TABLE
(each inverter)

| INPUT A | OUTPUT Y |
|------------|-------------|
| H | L |
| L | H |

REFERENCES

1. Neubauer, W.G., Dragonette, L., "Experimental determination of the freefield sound speed in water", *J. Acoust. Soc. Am.* 36 (1964) 1685-1690.
2. Ammann, J.J., Galaz, B., "Sound velocity determination in gel-based emulsions", *Ultrasonics*, 41 (2003) 569-579.
3. Babick, F., Hinze, F., Ripperger, S., "Dependence of ultrasonic attenuation on the material properties", *Colloids and Surfaces*, (2000) 33-46.
4. Hipp, A.K., Storti, G., Morbidelli, M., "Acoustic Characterization of Concentrated Suspensions and Emulsions", *Langmuir* 2002, 18, 405-412.
5. Chanamai, R., Coupland, J.N., McClements, D.J., "Effect of temperature on the ultrasonic properties of oil-in-water emulsions", *Colloids and Surfaces*, 139 (1998) 241-250.
6. Alba, F., Crawley, G.M., Fatkin, J., Higgs, D.M.J., Kippax, P.G., "Acoustic spectroscopy as a technique for the particle sizing of high concentration colloids, emulsions and suspensions", *Colloids and Surfaces*, 153 (1999) 495 – 502.
7. J.K. Allegra and S.A. Hawley, "Attenuation of Sound in Suspensions and Emulsions. Theory and Experiments," *Journal of the Acoustic Society of America* 51, (1971) 1545-1564.
8. Dukhin, A.S., Goets, P.J., "Acoustic and electroacoustic spectroscopy for characterizing concentrated dispersions and emulsions", *Advances in Colloid and Interface Science*, 92 (2001) 73-132.
9. Caperan, Ph., Somers, J., Richter, K., Fourcaudot, S., "Acoustic Agglomeration Of A Glycol Fog Aerosol: Influence Of Particle Concentration And Intensity Of The Sound Field At Two Frequencies", *Journal of Aerosol Science*. 26, (1995) 595-612.
10. Peters, F., Petit, L., "A broad band spectroscopy method for ultrasound wave velocity and attenuation measurement in dispersive media", *ultrasonics* 41, (2003) 357-363.
11. American Institute of Ultrasound in Medicine Bioeffects Committee: "Bioeffects Considerations for the Safety of Diagnostic Ultrasound". *Journal of Ultrasound in Medicine* (1988), 1-38.
12. Barnett S.B., Haar G.R., Ziskin M.C., Nyborg W.L., Maeda K., Bang J., "Current status of research on biophysical effects of ultrasound". *Ultrasound in Medicine and Biology* 1994, 205-218.