

Copyright Warning & Restrictions

The copyright law of the United States (Title 17, United States Code) governs the making of photocopies or other reproductions of copyrighted material.

Under certain conditions specified in the law, libraries and archives are authorized to furnish a photocopy or other reproduction. One of these specified conditions is that the photocopy or reproduction is not to be “used for any purpose other than private study, scholarship, or research.” If a user makes a request for, or later uses, a photocopy or reproduction for purposes in excess of “fair use” that user may be liable for copyright infringement,

This institution reserves the right to refuse to accept a copying order if, in its judgment, fulfillment of the order would involve violation of copyright law.

Please Note: The author retains the copyright while the New Jersey Institute of Technology reserves the right to distribute this thesis or dissertation

Printing note: If you do not wish to print this page, then select “Pages from: first page # to: last page #” on the print dialog screen

The Van Houten library has removed some of the personal information and all signatures from the approval page and biographical sketches of theses and dissertations in order to protect the identity of NJIT graduates and faculty.

ABSTRACT

A COMPUTATIONAL MODEL OF SPASTICITY BASED ON A DECOUPLING OF THE ALPHA AND GAMMA EFFERENTS

by

Bruno A. Mantilla

It is generally accepted that spasticity results from changes in the excitability of the stretch reflex. This change lowers the threshold of the motoneurons of the spinal cord where the integration of a signal from velocity/position sensors is processed and then fed back to the contracting muscle (alpha-extrafusal and gamma-intrafusal fibers). The stretch reflex depends on the initial length of the muscle, the stretch velocity and voluntary activity. The exact sequence of the triggering events remains unknown, is poorly understood and as a result is controversial. The clinical classification scales are mainly subjective and by definition, inaccurate.

This computational model of spasticity is based on the concept of the existence of a normal neuromuscular control coupling function, which ordinarily encloses the extrafusal and intrafusal fibers, and explains the spasticity as a result of the uncoupling of this normal mechanism. The model involves mechanical parameters and basic neuromuscular control theory.

**A COMPUTATIONAL MODEL OF SPASTICITY BASED ON A DECOUPLING
OF THE ALPHA AND GAMMA EFFERENTS**

**by
Bruno A. Mantilla**

**A Thesis
Submitted to the Faculty of
New Jersey Institute of Technology
in Partial Fulfillment of the Requirements for the Degree of
Master of Science in Biomedical Engineering**

Department of Biomedical Engineering

May 2002

Blank Page

APPROVAL PAGE

ABSTRACT

**A COMPUTATIONAL MODEL OF SPASTICITY BASED ON A DECOUPLING
OF THE ALPHA AND GAMMA EFFERENTS**

Bruno A. Mantilla

Dr. Richard Foulds, Thesis Advisor **Date**
Associate Professor and Associate Chair for Research,
Biomedical Engineering, NJIT

Dr. David Kristol, Committee Member **Date**
Professor and Acting Chair, Biomedical Engineering, NJIT

Dr. Tara Alvarez, Committee Member **Date**
Assistant Professor, Biomedical Engineering, NJIT

BIOGRAPHICAL SKETCH

Author: Bruno A. Mantilla

Degree: Master of Science in Biomedical Engineering

Date: May 2002

Undergraduate and Graduate Education:

Master of Science in Biomedical Engineering,
New Jersey Institute of Technology, Newark, NJ, 2002

Postdoctoral Research Associate Fellow.
University Of Illinois at Chicago. Chicago. IL, 1994

Neurosurgeon
Escuela Militar de Medicina, Bogotá, Colombia, 1985

Doctor en Medicine and Surgery
School of Medicine Universidad del Rosario, Bogotá, 1980

Presentations and Publications:

Society Of Manufacturing Engineers, New Jersey Chapter
Guest Speaker Hasbrouck Heights, NJ, March 2001

First National Symposium on Lumbar Pain. Lecturer
Clinica Reina Sofía. Bogotá, July 1998

First Course Update on Neurology and Neurosurgery Emergencies. Lecturer
Clinica Reina Sofía. Bogotá, March 1997

VII National Medical Congress. Lecturer
Hospital Central de la Policia. Bogota, July 1992

To the women that own my heart:

**my mother, my wife, my daughter,
without you there would be no light.**

To my father, your crazy brain will always be an inspiration.

To my son, mighty giant, you are simply much better than me.

ACKNOWLEDGEMENT

To Dr. Richard Foulds, noble hearted knight, you opened the door to a new life.

I will never have enough words to express my gratitude.

To Dr. David Kristol and Dr. Tara Alvarez, thank you. The time and advice given really helped.

To the NJIT Department Of Biomedical Engineering for providing me a research assistantship.

To the NJIT Biomedical Engineering Faculty who gave me not only their knowledge but also their friendship, and trusted that I could make the transition from physician to engineer.

To Dr. Sue Ann Sisto of the Kessler Medical Rehabilitation Research and Education Corporation, whom with generosity and warmth allowed me into the group and their research.

To my family who still supports my soul and spirit during this endless journey.

To Darnell, Rob, Gene, Don, Peerajak -Dr. Foulds' laboratory team- and Jason nice comrades. Neither our dreams nor our struggles prevented us from helping each other.

To German Correa: even though it is about more than thirty years of friendship and not about encouragement, endorsement, patronage, support, sponsorship, parachute, protection, warning, caution, reprimand, upbraid, berate, rail. I know I can always count on you for any one of these.

To the U.S.A. who opened its hands and received me.

TABLE OF CONTENTS

Chapter	Page
1 INTRODUCTION	1
2 BACKGROUND REVIEW	4
2.1 Skeletal Muscle	5
2.2 Proprioception and Feedback	10
2.3 Assessment of Spasticity	14
2.4 Clinical Assessment	18
3 THE MODEL	31
4 RESULTS	72
5 DISCUSSION	104
6 FINAL CONSIDERATIONS	112
REFERENCES	116

LIST OF TABLES

Table	Page
1 Ashworth Scale	19
2 Modified Ashworth Scale	19

LIST OF FIGURES

Figure	Page
2.1. Microscopic Appearance Of The Muscle	6
2.2. Diagram Representing The Muscle Contraction.....	7
2.3. Artistic Representation of The Muscle and T-Tubule System.....	9
2.4. Muscle spindle with alpha and gamma fibers.....	11
2.5. Explanatory diagram of the stretch reflex.....	11
2.6. Diagram Showing the three possible relations between intrafusal and extrafusal fibers.....	12
2.7. Artistic Diagram Of The Stretch Reflex	13
2.8. Typical Oscillation Of A Normal Subject	17
3.1. Underdamped Oscillator Second Order Linear Differential Equation	36
3.2. First Model -Starting Point -	38
3.3. Underdamped Oscillator -Position-Second Order Differential Equation (sine function).....	39
3.4. Second Model -Sine Function -	40
3.5. Underdamped Oscillator-Position-Second Order Differential Equation (muscle contribution-switch OFF).....	42
3.6. Underdamped Oscillator -Acceleration- Second Order Differential Equation (muscle contribution-switch OFF).....	43
3.7. Torque Contribution- (muscle contribution-switch OFF).....	43
3.8. Third Model – Muscle	44
3.9. Underdamped Oscillator-Position-Second Order Differential Equation (muscle contribution-switch ON)	45

**LIST OF FIGURES
(Continued)**

Figure	Page
3.10. Underdamped Oscillator -Acceleration- Second Order Differential Equation(muscle contribution-switch ON)	45
3.11. Spasm Torque Contribution- (muscle contribution-switch ON)	46
3.12. Underdamped Oscillator -Position-Second Order Diff. Equation (multiple muscle contribution-switch ON)	47
3.13. Underdamped Oscillator -Acceleration-Second Order Diff. Equation (multiple muscle contribution-switch ON)	47
3.14. Torque Contribution (Multiple muscle contribution-switch ON).....	48
3.15. Third Models - Multiple Muscle Contribution-	49
3.16. Underdamped Oscillator -Position-Second Order Diff. Equation (multiple muscle contribution-switch ON)	50
3.17. Underdamped Oscillator -Acceleration-Second Order Diff. Equation (multiple muscle contribution-switch ON)	50
3.18. Torque Contribution(Multiple muscle contribution-switch ON).....	51
3.19. Fourth Model – Switch ON/OFF	52
3.20. Switch On/Off (Switch Off)- Position-	53
3.21. Switch On/Off (Switch On)- Position-	54
3.22. Switch On/Off (Switch On)- Acceleration-	54
3.23. Switch On/Off (Switch On)- Muscle Torque –.....	55
3.24. Switch On/Off (Switch On Permanent End)-Position-	56
3.25. Switch On/Off (Switch On-Permanent End)–Acceleration	56
3.26. Switch On/Off (Switch On-Permanent End)– Muscular Torque.....	57

**LIST OF FIGURES
(Continued)**

Figure	Page
3.27. Fourth Model – Switch ON/OFF (increasing Damping Coefficient)	58
3.28. Switch On/Off (Increasing Damping Coefficient)-Position	59
3.29. Switch On/Off (Increasing Damping Coefficient)-Acceleration	59
3.30. Switch On/Off (Increasing Damping Coefficient)-Torque.....	60
3.31. Severe Spasticity (Permanent Contraction)– Position	62
3.32. Severe Spasticity (Permanent Contraction)– Torque.....	62
3.33. Fith Model – Severe Spasticity	63
3.34. Severe Spasticity (Permanent Contraction)– Acceleration.....	64
3.35. Sixth Model – Final Model- Pendulum Knee Drop Test.....	67
3.36. Final Model –Knee Drop Pendulum Test – Position- (No Spasticity)	68
3.37. Final Model –Knee Drop Pendulum Test – Position- (Mild Spasticity)	69
3.38. Final Model –Knee Drop Pendulum Test – Position- (Moderate Spasticity).....	69
3.39. Final Model –Knee Drop Pendulum Test – Position- (Severe Spasticity)	70
3.40. Final Model –Knee Drop Pendulum Test–Position- (Very severe Spasticity)	71
4.1. Normal Subject- Position.....	72
4.2. Normal Subject- Position.....	73
4.3. Normal Subject- Acceleration.....	73
4.4. Normal Subject- Muscle Torque.....	74
4.5. Gamma 90 % - Position	74

**LIST OF FIGURES
(Continued)**

Figure	Page
4.6. Gamma 90 % - Velocity	75
4.7. Gamma 90 % - Acceleration.....	75
4.8. Gamma 90 % Muscle Torque	76
4.9. Gamma 90 % Basal tone.....	76
4.10. Gamma 80 % Position	77
4.11. Gamma 80 % Velocity.....	77
4.12. Gamma 80 % Acceleration	77
4.13. Gamma 80 % Muscle torque.....	78
4.14. Basal tone.....	78
4.15. Fourth Simulation Gamma 70%-Position.....	79
4.16. Fourth Simulation Gamma 70%-Velocity	79
4.17. Fourth Simulation Gamma 70%-Acceleration.....	79
4.18. Fourth Simulation Gamma 70%-Torque	80
4.19. Fourth Simulation Gamma 70%-Basal	80
4.20. Fifth Simulation Gamma 60 % Position	81
4.21. Fifth Simulation Gamma 60% Velocity	81
4.22. Fifth Simulation Gamma 60% Acceleration.....	81
4.23. Fifth Simulation Gamma 60% Torque.....	82
4.24. Fifth Simulation Gamma 60% Basal Tone	82

LIST OF FIGURES
(Continued)

Figure	Page
4.25. Sixth Simulation Gamma 50 %Position	83
4.26. Sixth Simulation Velocity.....	83
4.27. Sixth Simulation Acceleration	83
4.28. Sixth Simulation Gamma 50% Torque	84
4.29. Sixth Simulation Gamma 50% Torque Basal Tone.....	84
4.30. Seventh Simulation Gamma 40% position	85
4.31. Seventh Simulation Gamma 40% Velocity	85
4.32. Seventh Simulation Gamma 40% Acceleration.....	85
4.33. Seventh Simulation Gamma 40% Torque.....	86
4.34. Seventh Simulation Gamma 40% Basal Tone	86
4.35. Eighth Simulation Gamma 30 % Position	87
4.36. Eighth Simulation Gamma 30 % Velocity.....	87
4.37. Eighth Simulation Gamma 30 % Acceleration.....	87
4.38. Eighth Simulation Gamma 30 % Torque.....	88
4.39. Eighth Simulation Gamma 30 % Basal Tone	88
4.40. Ninth Simulation Gamma 20 % Position.....	89
4.41. Ninth Simulation Gamma 20 % Velocity	89
4.42. Ninth Simulation Gamma 20 % Acceleration	89

**LIST OF FIGURES
(Continued)**

Figure	Page
4.43. Ninth Simulation Gamma 20 % Torque	90
4.44. Ninth Simulation Gamma 20 % Basal Tone.....	90
4.45. Ninth Simulation Gamma 10 % Position.....	91
4.45. Ninth Simulation Gamma 10 % Position.....	91
4.46. Ninth Simulation Gamma 10 % Velocity	91
4.47. Ninth Simulation Gamma 10 % Acceleration	91
4.48. Ninth Simulation Gamma 10 % Torque	92
4.49. Ninth Simulation Gamma 10 % Basal Tone.....	92
4.50. Tenth Simulation Gamma 1 % Position.....	93
4.51. Tenth Simulation Gamma 1 % Velocity.....	93
4.52. Tenth Simulation Gamma 1 % Acceleration	93
4.53. Tenth Simulation Gamma 1 % Torque	94
4.54. Tenth Simulation Gamma 1 % Basal Tone.....	94
4.55. Alpha/Gamma activating function.....	95
4.56. Decrementd function of gamma.....	96
4.57. Alpha /Gamma relation as a function of severity of the spasticity	96
4.58. Activating factor as a function of severity of the spasticity.....	97
4.59. Muscle intermittent isolated torque contribution as function of alpha/gamma variation	98

LIST OF FIGURES
(Continued)

Figure	Page
4.60. Muscle basal tone contribution as function of alpha/gamma variation	99
4.61. Normal Patient	99
4.62. Normal Simulation.....	100
4.63. Mildly spastic patient.....	100
4.64. Mildly spastic simulation.....	101
4.65. Moderate to severe spastic patient	101
4.66. Moderate to severe spastic simulation	102
4.67. Severe spastic patient.....	102
4.68. Severe spastic simulation.....	103
5.1. Basal tone regulating function	107
5.2. Intermittent muscle contraction regulating function.....	108
5.3. Integrated muscle switch regulation	109
5.4. Activation factor as a function of gamma decrement	110
5.5. Isolated muscle activation as a function of gamma decrement.....	110

CHAPTER 1

INTRODUCTION

Biomedical Engineering is a novel developing discipline, which, through a multidisciplinary approach, seeks the recognition, description, comprehension and solution of various problems in medicine and biology, using the most recent and advanced knowledge in science, engineering and technology.

Biomedical Engineering is always directed to improving the quality of life of people with blemished medical status that limits their independent life and impairs their integration into the community. Biomedical Engineering runs parallel to medicine giving a new point of view to complex existing problems.

Whenever a problem has appeared in medicine, the first task has been to identify it. This work is not always easy because medicine is not a coherent, complete and exact body of knowledge. On the contrary it has numerous gaps inside itself, gaps that need to be addressed and hopefully corrected.

In medical practice, a large number of uncertainties are found in daily practice. Some of them might not have been even identified. Or maybe, by numerous reasons, some of them have not received the attention or the time they certainly deserve. The next step after identifying an uncertainty or an abnormality is to describe it. It is implied that you, some how, have seen something unknown to others. However, a description of the expression, of some underlying abnormality, is extremely different from understanding its main cause of existence. Notwithstanding not solving the cause yet, a new concept, and a new entity has already been created.

This entity becomes part of the public domain and the whole community of specialist will drive their attention to it, even from cross related specialties, in a joined competition to bring light into the origin. Now everyone wants to contribute and with all his or her effort give a full explanation or even a clue towards the understanding of these phenomena. Also, giving new terms and new concepts that might make it clear, but frequently this community effort ends doing the opposite effect and makes it more complex and difficult to understand. Which, by the way, is the most common situation we find in our days when we first approach a problem. Surprisingly, after some short time, the whole community of experts results in “walking in circles” around the same points of accepted knowledge, not withstanding the fact the acquired knowledge is not complete.

The Greek word *deiknynai* means to show, which is extended to *dikE* judgment. It is extended also to *para-* + *deiknynai* which forms *paradeiknynai* meaning to show side by side. These gives origin to the Greek word *paradeigma* converted to the Late Latin *paradigma*, which was later introduced- in the 15th century- to the English language as *paradigm*.

A paradigm in its most strict meaning is, “an example of a conjugation or declension showing a word in all its inflectional forms”. When this is done it is expected a full knowledge and understanding of the concept is enclosed in that word. Paradigm was later extended to, “an outstandingly clear or typical example or archetype.” Today its most accepted use is, “a philosophical and theoretical framework of a scientific school or discipline within which theories, laws, generalizations and the experiments performed in support of them are formulated,” in three words, “an accepted truth.”

Frequently medicine moves on these types of basic postulates of “accepted truth” and constructs a whole knowledge around them. It has to be functional and very efficient in very little time, nearly immediate.

Identifying the leading forces that govern the paradigm changes is of interest to many disciplines. Management and economics, not to be surprisingly are listed among the most concerned with these factors. Barker in his book “Paradigms, The Business of Discovering The Future”[2] reviews the advance and evolution of the industry - which is controlled by economic needs and rules - and shows how much it is intimately related to the development of new technology, which is not surprising. What is fascinating is that the development of new technology is related to, “a new way of looking at old problems”. Traditionally, it has happened when, by fortune or serendipity, an “outsider” (obviously a curious one) meets in the precise site and in the precise minute with a group of “insiders” studying the particular problem. [3]

What will now happen is definitely related to a new perspective, of the problem (incognito), is applied catalyzing and developing it in a new fashion. This is what he calls a change on the paradigm, all the related factors that define the state of the art are suddenly affected by a new concept that, in an undeniable way, changes their dynamic. Consequently, it allows a step forward in knowledge and development of new technology. Obviously, this gives an advantage for the local industry developing the new applied technology.

The big challenge faced today by both disciplines, biomedical engineering and medicine, is to work together in order to find new perspectives which lead to solutions of old problems.

CHAPTER 2

BACKGROUND REVIEW

The Greek word spastikos, which means contraction, gives origin to the Latin spasticus where the word spasticity originates. [1]

The most common accepted definition for spasticity is “a motor disorder characterized by a velocity-dependent increase in tonic stretch reflexes with exaggerated tendon jerks, resulting from hyperexcitability of the stretch reflex, as one component of the upper motor neuron syndrome.” Symptoms may include hypertonicity, clonus, exaggerated deep tendon reflexes, muscle spasms, and scissoring and fixed joints. Although, the underlying etiologies are multiple, this term has been used to indistinctively describe an altered pattern of physical movement. The spastic phenomena is the most frequent and severe condition that hampers the recovery and rehabilitation, from numerous pathologies which include stroke, cerebral palsy, spinal cord injury, multiple sclerosis, CNS degenerative disease, and other pathologies. [15, 7, 19]

It is accepted that spasticity results from changes in neural excitability. Lowering the threshold of the stretch reflex involved neurons in the spinal cord where the integration of a signal from a velocity/position sensor information is processed, and then is fed back to the contracting muscle (alpha motor neuron actuator and gamma intrafusal fibers). This reflex depends on the initial length of the muscle and the stretch velocity as well as voluntary control signal decoding from the central nervous system. However, the exact sequence of the triggering events remains unknown, poorly understood and by consequence remains controversial. [9, 25, 33, 41]

2.1 Skeletal Muscle

The skeletal muscle is formed by an array of multiple muscle fibers. Each of these fibers is a single skeletal muscle cell. The muscle fibers lie parallel to each other and they are joined at the end of the muscle to a specialized type of connective tissue, the tendon that attaches them to the bone. The muscle fiber is composed of myofibrils. Each myofibril consists of a regular arrangement of thick filaments – myosin- and thin filaments –actin-. The different bands of all the myofibrils, lined up in a parallel fashion, produce the striated appearance of a skeletal muscle fiber. [9]

An “A” band (an-isotropic) consists of a stacked set of thick filaments along with the portion of thin filaments that overlap on both ends of the thick filaments. The thick filaments are found only in the A band area. The H zone is the middle point of the A band, where the thin filaments does not reach; are formed exclusively by thick filaments, and in consequence it appears lighter. The portion of the thin filaments that does not overlap the A band forms the I band (isotropic). By definition it is formed exclusively by a portion of the thin filament. In the middle of each I band is a dense, vertical line known as the Z line. The area between two Z lines is the functional unit of the muscle known as a sarcomere.

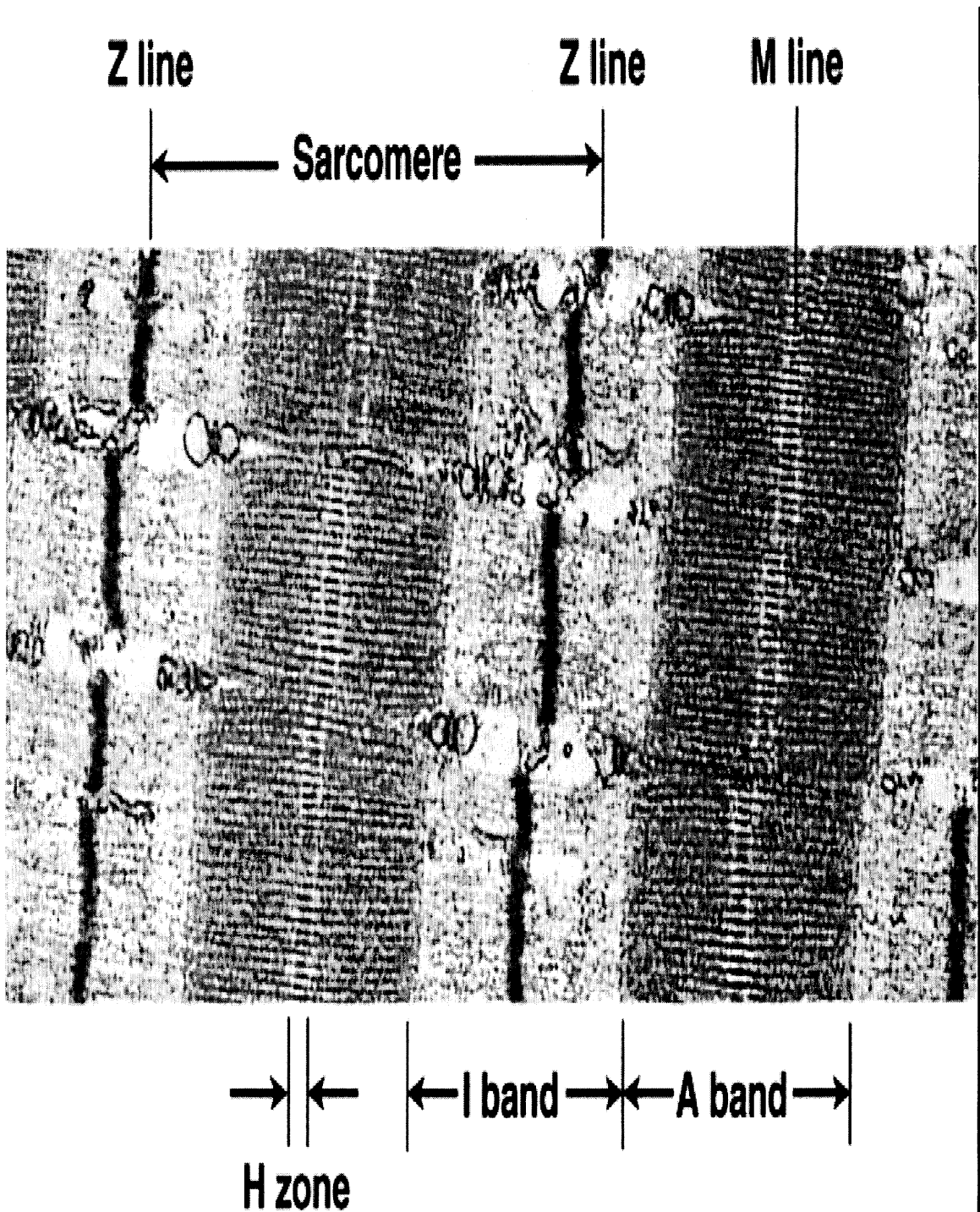

Figure 2.1. Microscopic Appearance Of The Muscle

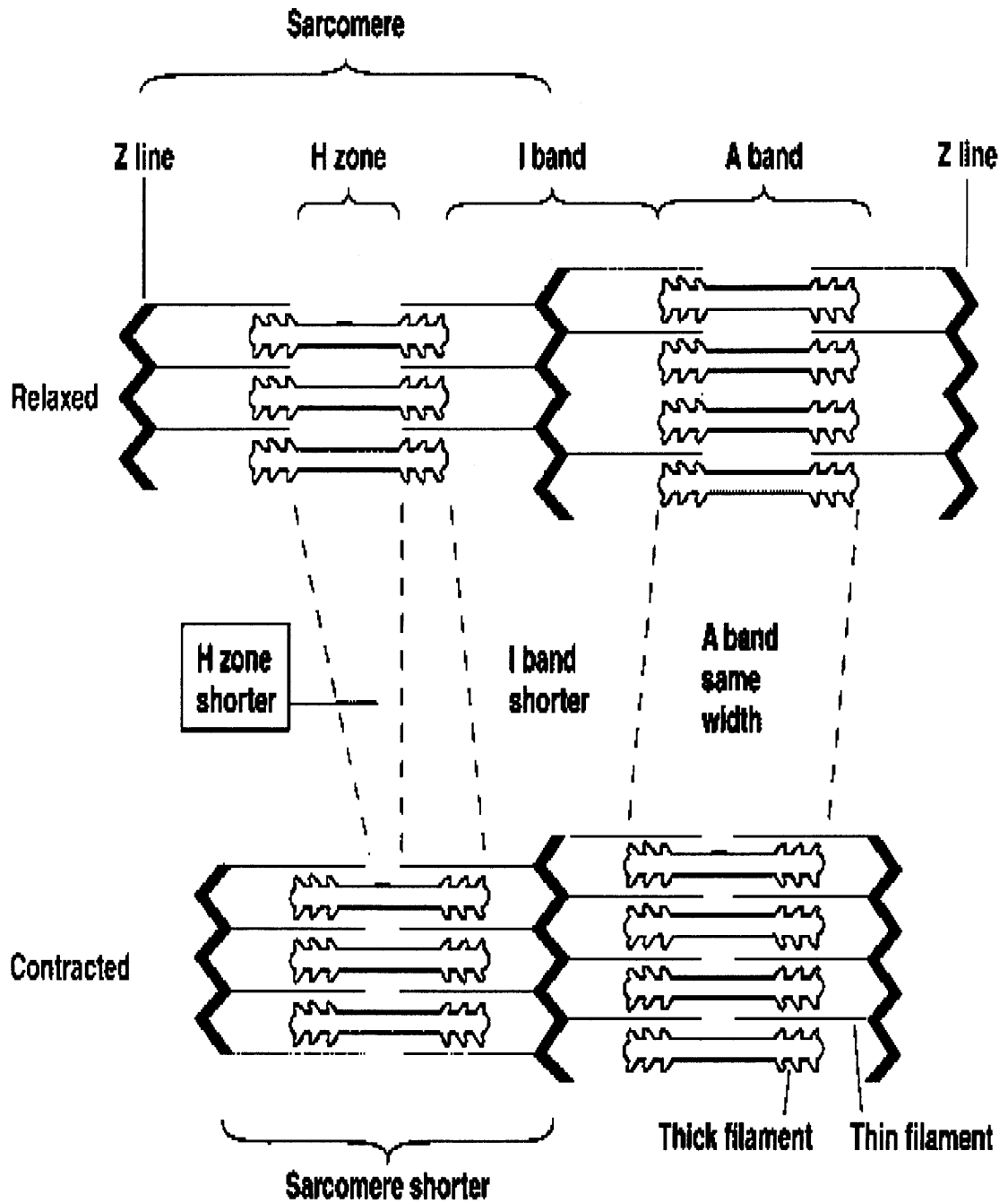

Figure 2.2. Diagram Representing The Muscle Contraction

The thin filaments on each side of a sarcomere slide inward toward the A band's center during contraction. In this way they pull the Z lines, to which they are attached, closer together. As a result the sarcomeres size diminishes and the muscle contracts. This is known as the sliding mechanism of the muscle contraction.

When the acetylcholine is released from nerve terminals at the neuromuscular junction, the skeletal muscles cells are activated. At each junction of the A band, the surface membranes dips deeply into the muscle fiber to form a transverse tubule (T - Tubule). The T - Tubule runs perpendicularly from the surface of the muscle fiber, and, adjacent to the lateral sacs of the endoplasmic reticulum of the muscle (sarcoplasmic reticulum). Calcium is stored in the lateral sacs of the sarcoplasmic reticulum and is rapidly released upon a propagation of an action potential. The released calcium triggers a series of steps that will finally end in the coupling of actin and myosin associated with the breakdown of a molecule of ATP and the consumption of energy.

Voluntary muscle contraction is controlled by descending signals from suprasegmental central nervous system that converge on to the alfa motoneuron, on the anterior horn of the spinal cord, where the final nerve impulse to the muscle is originated. This concept is known as the final pathway. The different processes that impact on the suprasegmental control of movement are beyond the scope of the present review. However, it is worth stating that their variations are as diverse in origin as are the etiologies underlying the spastic phenomenon.

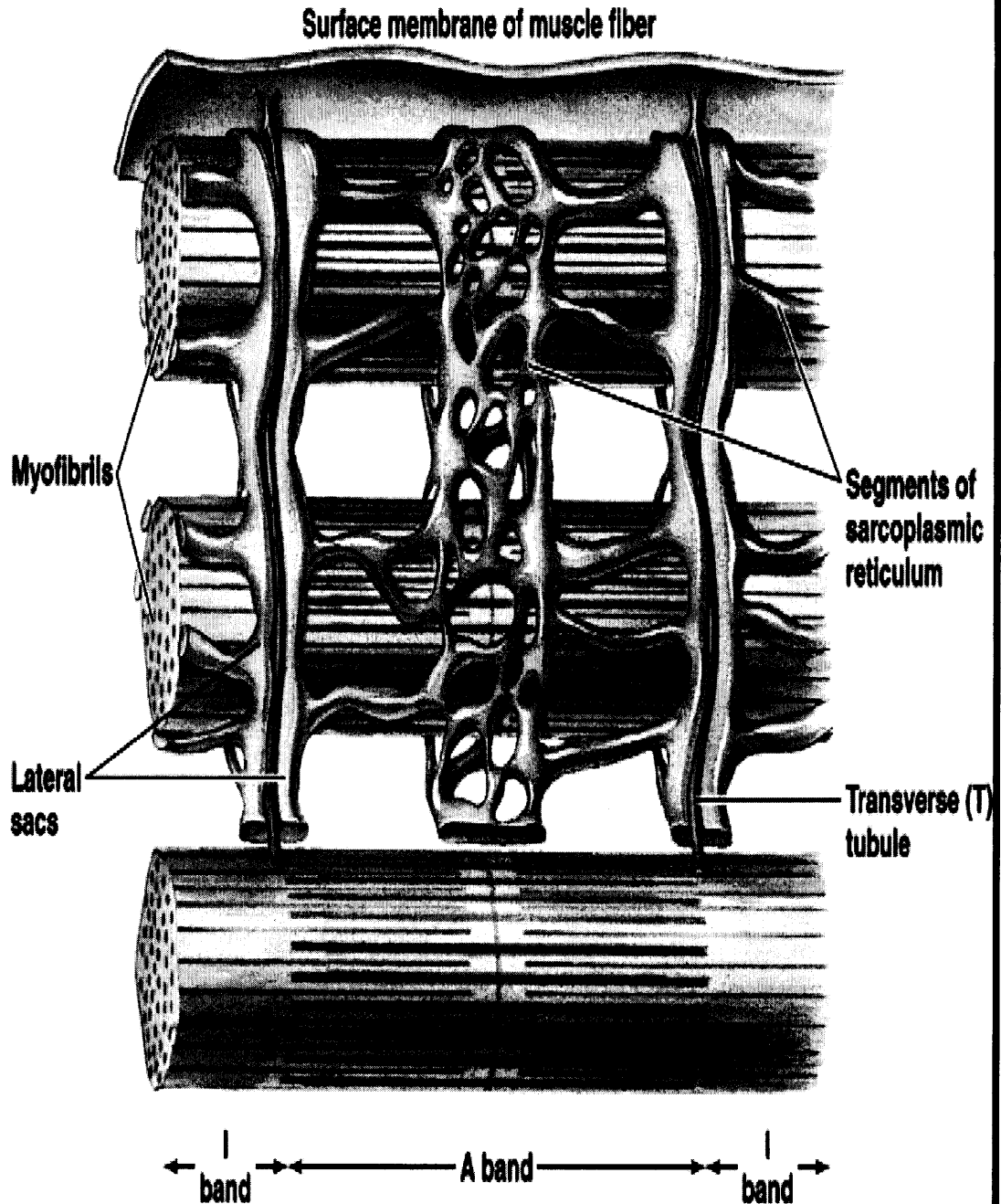

Figure 2.3. Artistic Representation of The Muscle and T-Tubule System

The present study will center on the consequences of alterations believed to occur at the spinal cord (segmental control) control of the motor function. These result from various disorders of the central nervous system and produce an uncoordinated (uncoupled) type of movement that is particularly inefficient, where a high amount energy is used for any intended task. This increase in required energy constitutes the basis of our analysis of spasticity. [20, 21, 9]

2.2 Proprioception and Feedback

It is very important for the CNS to monitor the orientation of joints and derive the three dimensional position of limbs, in order to program and adequately produce any movement. This type of information is referred as proprioception. Information is gathered from various sensors located in muscles, joints and skin, and is integrated with information coming from visual and vestibular input at different levels of the CNS: spine, brainstem, cerebellum, cerebral cortex and basal ganglia. [9, 25]

The Muscle Spindle and the Golgi Tendon Organ act concomitantly to regulate the different characteristics of the muscle. The Golgi Tendon Organ senses the tension. Muscle spindles consist of collections of specialized muscle fibers known as intrafusal fibers, which lie within the spindle shaped connective tissue capsules parallel to the ordinary extrafusal fibers. The principal function of the muscle spindle is to monitor and set up the desired length and related rate of change of this length in the muscle. It is connected in parallel fashion to the rest of the muscle, the extrafusal muscle fibers.

The spinal cord gives origin to efferent fibers from two different types of motoneurons: alpha motoneurons convey signals that determine the contraction of

extrafusal fibers and hence the entire muscle. The gamma motoneurons connect directly to the muscle spindles. They have relatively slow conduction and control their resting tension or tone. [20, 21, 25, 26]

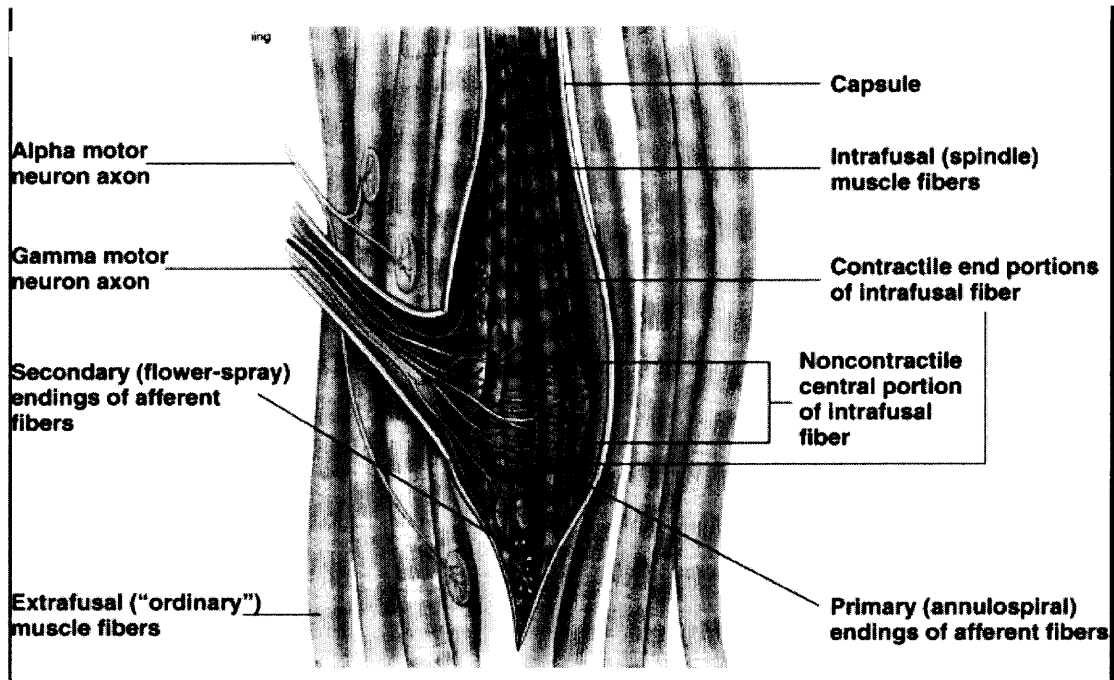

Figure 2.4. Muscle spindle with alpha and gamma fibers

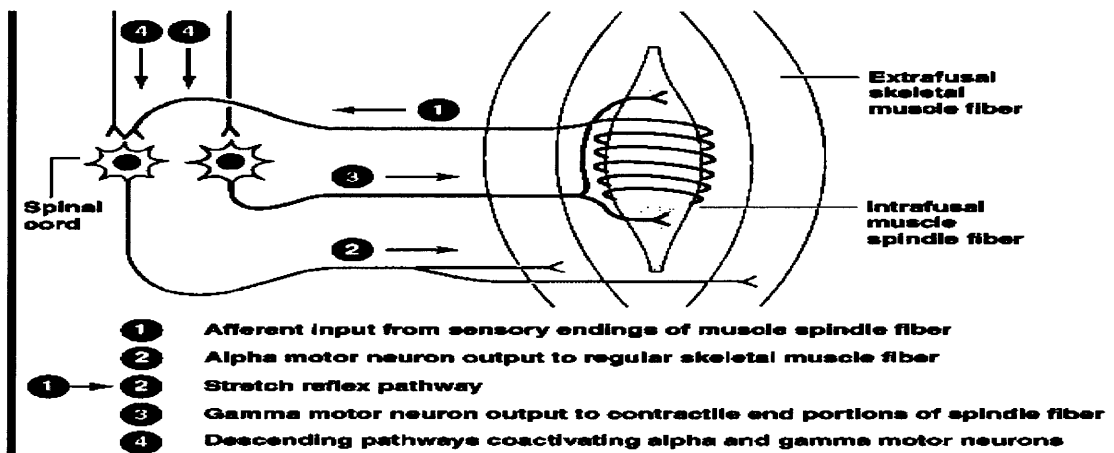

Figure 2.5. Explanatory diagram of the stretch reflex

The muscle spindle is comprised of two types of neural endings: The primary annulospiral endings, which wrapped in the central portion of the intrafusal fibers, detect the change (dimension-position) in length and the rate of change in length (velocity). The secondary flower-spray endings located at the lateral region of the muscle intrafusal fibers and are sensitive only to length differences. Whenever the muscle is passively stretched the intrafusal fibers are likewise stretched, increasing the rate of firing in the afferent fibers. When the rate of change of the length of the muscle is more than the expected, by the set up of the intrafusal fibers in relation to the extrafusal fibers, an action potential arises in the intrafusal afferent neuron. This afferent pathway directly synapses with the alpha motoneuron that innervates the extrafusal fibers of the same muscle resulting in muscular contraction. This negative feedback triggers an alpha efferent, which stimulates contraction that restores the muscle to its original length. This sequence of events is known as the stretch reflex or the myotatic reflex.

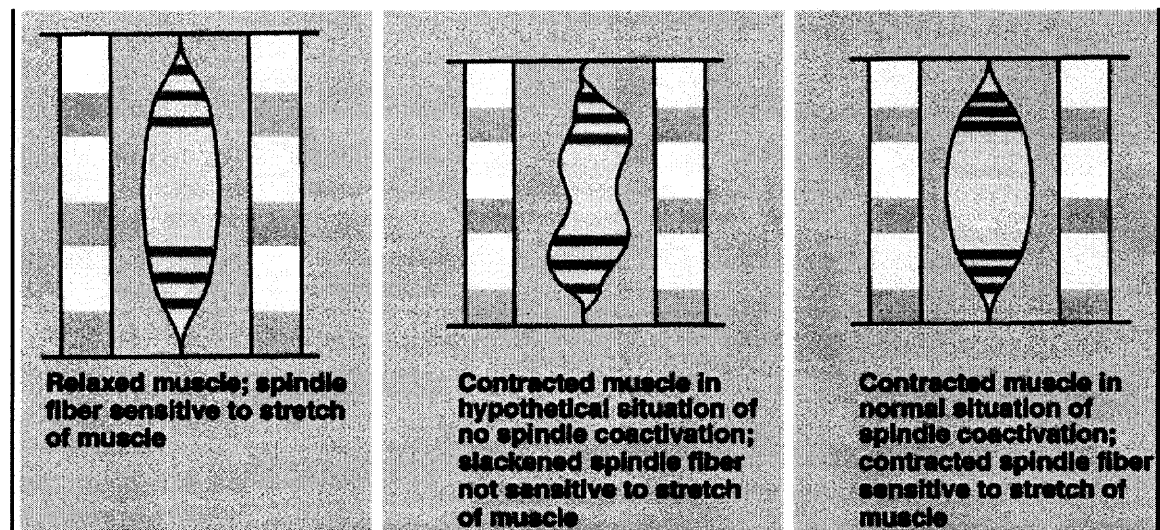

Figure 2.6. Diagram Showing the three possible relations between intrafusal and extrafusal fibers

The sensitivity and rate of change of the length of the muscle fibers (intra / extra-fusal relation) is dependant on complex relations and integration of suprasegmental levels of motor control. When this balance is altered or damaged, by different etiologies, a segment of the spinal cord loses the influence or control from the suprasegmental centers. This is referred as an emancipation process or “liberation effect”, which creates and hyper- responsive state. One of the most common ways of expression of these “liberation“ is the spasticity. [20, 21, 35, 36, 40]

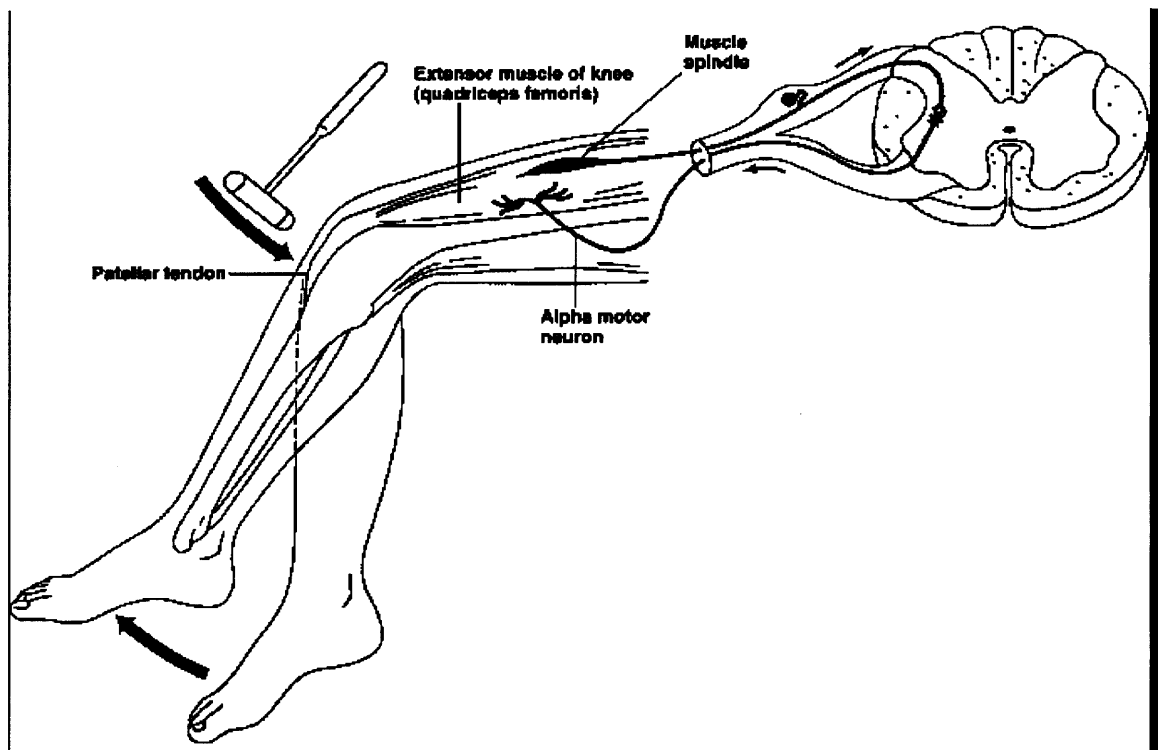

Figure 2.7. Artistic Diagram Of The Stretch Reflex

2.3 Assessment of Spasticity

In 1919, Robert Wartenberg (1887 – 1959) graduated from the University of Rostock, a port in north East Germany near the Baltic coast. After working in Hamburg (Germany) and in Breslau (Poland), he left Germany in 1935, after persecution by the Nazis, and settled in San Francisco. In 1952, he was appointed clinical professor of neurology at the University of California

Among his numerous biographers, Dr. Louis D. Boshes from the University of Illinois at Chicago wrote: “ This "Sherlock Holmes" in the discipline of neurology, always searching for truth accuracy and dependability of researcher, clinician or writer, advanced his endowment into book reviewing. His acrid criticism was accurate, for the succeeding edition always embodied all recommendations, but at all times everyone benefited from the Wartenberg warmth, for he never made enemies with his microscopic scrutiny of facts in his unique but complete review of a tome.” [15]

Wartenberg (1951) was the first to analyze the pendulousness of the lower extremities, for diagnostic purposes. His work has special relationship to the assessment of spasticity. He would ask a patient to sit on the edge of a table with the legs hanging freely. An examiner would lift the patient's legs simultaneously to the same horizontal level, and release them; permitting them to swing freely. Parameters that were observed were the swinging time, the number of swings, the forward-swing and the backward movement.[40]

He found the swinging time and the number of swings to be diminished while the forward-swing was jerkier and of greater span and the backward movement was reduced.

He also described irregular “zigzag movements “ on the antero-posterior (sagittal) plane, and registered the swinging time of the right and left leg. The test was only estimated qualitatively. Further attempts to quantify the pendulum test were done by fastening an electric light to the big toe and recording the swinging movements on a film of a slowly moving camera.

Bajd and Bowman implemented the measurement of knee extensor spasticity by assessing the joint movement with an electrogoniometer. They used a switch on the patient's ankle, held by the examiner, as the signal to start the measurement, and surface EMG of the quadriceps to determine the beginning and duration of knee extensor activity. Knee joint goniogram, switch output and EMG potential were recorded by use of a visicorder light oscillograph. They reported it as very useful to objectify the pendulum testing results for spasticity and to be especially convenient to evaluate different approaches to reduce spasticity. [2]

Using the pendulum test, Boczko evaluated the treatment with antispastic drugs, while Bowman et al. and Vodovnik et al. studied the influence of electrical stimulation on spasticity. The first effort to quantify the pendulum swing test by assigning numbers to the deficits, was done by Schwab. His scale ranged from 0 as normal, (absence of any deficit in swing) to 4 with maximum rigidity, (total absence of swing). [4, 38, 39, 40]

Wartenberg described and Boczko confirmed 6 to 7 cycles in normal subjects and a reduced number of oscillations in spastic patients. Boczko measured the swinging time, T, and defined an 'amplitude ratio' for spasticity. Figure 1 shows a typical oscillation of a normal subject. [4, 40]

Bajd and Bowman tried to define the parameters that best characterized spasticity in their study and concluded that the initial drop of the leg was the most characteristic and representative feature showing the level of spasticity: [2]

“Spasticity in general, stops the swinging of then lower leg and pushes it back towards the starting position. Both events are represented by first minimum and first maximum of the measured knee goniogram. The two values can therefore be considered as an integral criterion of the degree of skeletal muscle spasticity.” [2]

Bajd and Vodovnik created a relaxation index R_2 as the ratio between the magnitude of the first drop A_1 and the magnitude of the initial angle A_0 . A normal value for R_2 was found to be 1.6 or more, consequently a normalized index R_{2n} was specified as $R_2/1.6$. Thus $R_{2n} > 1$ would denote a normal limb but $R_{2n} < 1$ would describe different degrees of spasticity. [2, 38]

Other two important parameters: the period, T , as well as the amplitude ratio, R_1 are illustrated in the figure. In normal subjects R_1 was found to be greater than 5, whereas patients with spasticity have an R_1 of about 2.6. Although this was progress in terms of a description of the phenomena, it did not describe, what were the causes for the difference in the values between normal and abnormal subjects from a dynamic point of view.

Bajd and Vodovnik after a thorough study tried to characterize the severity of spasticity by 8 different indexes, but again they did not give a real explanation of the acting parameters or what type of relation between them was represented in those indexes. [2,38]

$$R_1 = \frac{A_1}{A_1 - A_2} \quad (2.1)$$

$$R_2 = \frac{A_1}{A_0} \quad (2.2)$$

$$R_{2n} = \frac{A_1}{1.6A_0} \quad (2.3)$$

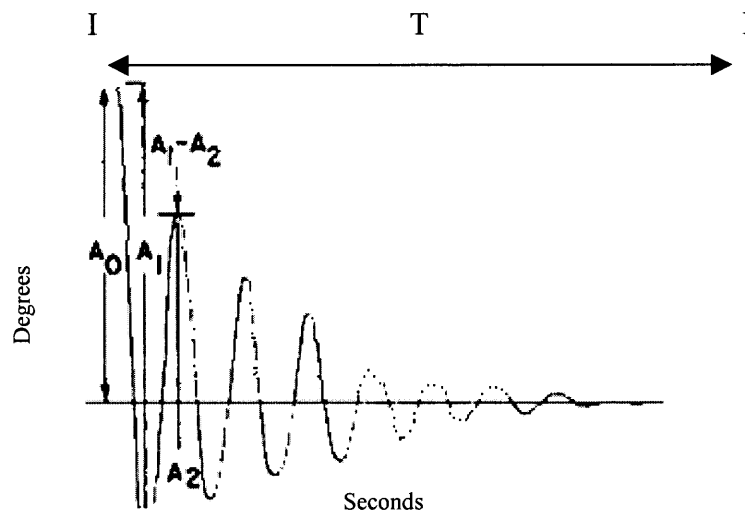

Figure 2.8. Typical Oscillation Of A Normal Subject.

At the present time clinical measurements of muscle spasticity, that are both valid and reliable, are very difficult to obtain. There is an overall agreement that there is need of better, precise and reliable scales for measuring spasticity. As Fowler pointed out, “The ability to quantify the presence and severity of spasticity is essential to understanding and treating spastic CP.” Bajd emphasized in 1982, “A need for an objective measurement of spasticity is unquestioned”. But still in year 2001, Pandayan

et. al. claimed: “The need to quantify neurological impairment is increasing rapidly with a perceived need to justify clinical procedures used routinely. The technical challenge of doing this relates to the need to provide reliable and sensitive measurement systems that can be used within the short time available at the clinic.” [2, 16, 28]

2.4 Clinical Assessment

There are two types of clinical measures that are generally used to assess muscle tone. The first type measures passive movement of the joint by applying a subjective ordinal scale to the resistance discerned by the examiner. It is implied that the examiners scale is always the same, particularly that his sensitivity and quantization does not vary.

The most common of these is the Ashworth Scale (AS) or its successor, the modified Ashworth scale (MAS). The reliability of the AS is still debated. Some researchers question its reliability as minimal at best, and unsuitable at worst. However other studies have shown it to have reasonably good intra-rater reliability, but with deficiencies in inter-rater reliability. [23, 28, 29, 31]

“ Evidence from this study supports previous findings suggesting that MAS may not have sufficient construct validity or reliability in assessing spasticity, however it may still provide a crude measure of resistance to passive movement.” [28]

Table 1 Ashworth Scale

0: No increase in muscle tone.

1: Slight increase in muscle tone, mild clasp-knife phenomenon, or minimal resistance at the end of the range of motion when the affected part(s) is moved in flexion or extension.

2: Slight increase in muscle tone, clasp-knife phenomenon, followed by minimal resistance throughout the remainder (less than half) of the range of motion.

3: More marked increase in muscle tone through most of the range of motion, but affected part(s) easily moved.

4: Considerable increase in muscle tone, passive movement difficult.

5: Affected part(s) rigid in flexion or extension.

Some, considering it has a good inter-rater variability and reproducibility, regards the clinical Ashworth Scale (AS) as very reliable. The AS has a trend to be a more popular choice among clinicians because of the relative ease of its execution, its expert based calibration and to its consequently “wider” applicability. [5, 35, 28, 29]

Table 2 Modified Ashworth Scale

0: No increase in muscle tone

1: Slight increase in muscle tone, manifested by a catch and a release or by minimal resistance at the end of the range of motion when the affected part(s) is moved in flexion or extension.

1+: Slight increase in muscle tone, manifested by a catch, followed by minimal resistance throughout the remainder (less than half) of the range of motion.

- 2: More marked increase in muscle tone through most of the range of motion, but affected part(s) easily moved.
- 3: Considerable increase in muscle tone, passive movement difficult.
- 4: Affected part(s) rigid in flexion or extension.

The second type of assessment objectively measures and records the resistance to passive joint movement present, while the limb is driven by gravitational force. The Wartenberg's pendulum test (WPT) is an example of this type of clinical test. Wartenberg's pendulum test has found some acceptance as a clinical test. The tester lifts the relaxed leg and releases it so that it swings by gravity. Angular velocity and number of swings are measured with goniometers or by other devices. More complicated biomechanical methods involve torque motors to measure the torque when a joint is moved. [2, 23, 38,40,]

One of the more frequent ways of calculating PT scores is as follows. The patient lies supine on a table with the legs positioned such that the knee joint is about 5 cm beyond the end of the table. The examiner supports the leg at the heel and releases it, allowing the limb to swing to a resting position. According to the method of Bajd and Vodovnik a PT score is calculated as a ratio of the total angular displacement (i.e., the first swing) to the displacement between the starting and final knee angles. [2]

Three knee angles are required for the calculation of R2n: the starting angle of the knee (normally full extension), the knee flexion angle on the first swing of the leg (first acute angle), and the final resting knee angle.

According to Bohannon et. al. the equation used to determine R2n is as follows:

$$R2n = \frac{(1st\ Acute\ Angle - Starting\ Angle)}{1.6 (Final\ Angle - Starting\ Angle)} \quad (2.4)$$

All angles refer to flexion-extension angles in the sagittal plane. PT scores range from 0 to approximately 1, with 0 being rigid and 1 being normal muscle tone. [5]

Fowler et. al. from UCLA, studied the “Sensitivity Of The Pendulum Test For Assessing Spasticity In Persons With Cerebral Palsy” comparing the PT with MAS (Modified Ashworth Scale). [15]

They concluded that the number and duration of oscillations, and the excursion of the first backward swing was very different between the normal and spastic people. The first oscillation was the best predictor of the severity of spasticity in people with cerebral palsy. The number of oscillations was useful in differentiating between normal and abnormal subjects but did not allow a classification for the severity of the spasticity. Fowler et. al. also concluded that the Relaxation Index, defined as the ratio between the first swing excursion and the difference between the resting and starting angles ($R I = \text{First Swing excursion} / \text{difference between starting and resting angles}$), was not reliable for classifying spastic patients. Even though the PT is an objective and highly repeatable measure, at this point its use has been limited to only a few muscle groups, such as the quadriceps, and its interpretation is still not well developed and understood. Neither type of muscle tone test is an ideal one. [15]

In an effort to better understand what is happening and what is being measured, we produce a more mathematical approach. This implies knowledge of basic concepts of the dynamics of an oscillating system.

For a free undamped oscillator, the equation that describes the motion, according to Newton's second law, is:

$$m\ddot{\Theta} = -K\Theta \quad (2.5)$$

Or rewriting it:

$$m\ddot{\Theta} + K\Theta = 0 \quad (2.6)$$

We can also define the ω_o as the natural frequency of the system, which is equal to:

$$\omega_o = \sqrt{\frac{k}{m}} \quad (2.7)$$

Meaning as well, that the square of the natural frequency (ω_o^2) multiplied by mass (m) gives the value of the elastic constant (k), also referred to as the spring constant. This k constant is an indicator of the system's capacity for storing elastic recoverable energy.

This equation can be re-written as:

$$\ddot{\Theta} + \omega_o^2 \Theta = 0 \quad (2.8)$$

The general solution for this equation is:

$$x_t = A \cos \omega_0 t + B \sin \omega_0 t \quad (2.9)$$

and if:

$$C = \sqrt{A^2 + B^2} \quad (2.10)$$

$$\cos \alpha = \frac{A}{C} \quad (2.11)$$

$$\sin \alpha = \frac{B}{C} \quad (2.12)$$

then:

$$x_t = C \left(\frac{A}{C} \cos \omega_0 t + \frac{B}{C} \sin \omega_0 t \right) \quad (2.13)$$

$$x_t = C (\cos \alpha \cdot \cos \omega_0 t + \sin \alpha \cdot \sin \omega_0 t) \quad (2.14)$$

$$x_t = C \cdot \cos(\omega_0 t - \alpha) \quad (2.15)$$

were:

C= amplitude

ω_0 =natural Frequency in radians per second

α =phase angle

Also the period (T) and the frequency (ν) in cycles per second can be calculated:

$$T = 2\pi / W_0 \quad (2.16)$$

$$\nu = 1/T = W_0 / 2\pi \quad (2.17)$$

T= period

ν = frequency in cycles per second

When an external force reduces the motion of an oscillator, the oscillator and its motion are said to be damped. At the time, when the oscillator stops oscillating, the system energy is expected to be totally transferred to the damping force. As the damping force is proportional to the velocity of the system, then the damping force (Fd):

$$F_d = -B\dot{\Theta} \quad (2.18)$$

Then if we include this term in the equation of the undamped system:

$$m\ddot{\Theta} + K\Theta = 0 \quad (2.19)$$

The equation for a free damped oscillation according to Newton's second law is:

$$m\ddot{\Theta} + B\dot{\Theta} + K\Theta = 0 \quad (2.20)$$

The energy relationship between the storing capacity and the damping capacity of the system is dictated by the relationship of the B (damping coefficient) and the K (spring coefficient),

$$W_o = \sqrt{\frac{k}{m}} \quad (2.21)$$

$$\text{Then } m \cdot W_o^2 = k \quad (2.22)$$

And the equation can be re written as:

$$m \ddot{\Theta} + B \dot{\Theta} + m W_o^2 \Theta = 0 \quad (2.23)$$

$$m\left(\ddot{\Theta} + \frac{B}{m}\dot{\Theta} + W_o^2\Theta\right) = 0 \quad (2.24)$$

And if:

$$b = \frac{B}{2m} \quad (2.25)$$

then:

$$m (\ddot{\Theta} + 2b\dot{\Theta} + \omega_o^2 \Theta) = 0 \quad (2.26)$$

The characteristic equation will be:

$$r^2 + 2br + \omega_o^2 r = 0 \quad (2.27)$$

Which will have two roots:

$$r_1, r_2 = -b \pm \sqrt{b^2 - \omega_o^2} \quad (2.28)$$

The relationship between B (damping coefficient) and K (spring coefficient) is defined by:

$$b^2 - \omega_o^2 = \frac{B^2}{4m^2} - \frac{k}{m} = \frac{B^2 - 4km}{4m^2} \quad (2.29)$$

Three different types of relationships have been described:

The first is when the damping capacity far exceeds the stored energy, so the system will dissipate the energy very rapidly and with no oscillation. This is called an overdamped case. [14]

The following relation characterizes it:

$$b^2 > 4km \quad (2.30)$$

And its solution is:

$$x(t) = c_1 e^{-r_1 t} + c_2 e^{-r_2 t} \quad (2.31)$$

In this case in which both roots are a real, and negative explaining the trend of:

$$X(t) = 0. \quad \text{As } t \rightarrow \infty \quad (2.32)$$

So the displacement occurs without any oscillation.

The following relationship characterizes the second case, which is known as critically damped, in this case:

$$b^2 = 4km \quad (2.33)$$

And:

$$r_1 = r_2 = -b \quad (2.34)$$

$$r_1 = r_2 = -b \pm \sqrt{b^2 - W_o^2} \quad (2.35)$$

as:

$$\sqrt{b^2 - W_o^2} = 0 \quad (2.36)$$

Then:

$$r_1 = r_2 = -b \quad (2.37)$$

Its solution is:

$$x(t) = c_1 e^{-rt} + c_2 t e^{-rt} = e^{-rt} (c_1 + c_2 t) \quad (2.38)$$

In this case the system is critically damped. This means that the damping force is just large enough to allow displacement with minimal oscillation.

As $e^{-rt} > 0$, and since $c_1 + c_2 t$ at most has one point crossing, the system will cross at most just once the zero position. [14]

It is also clear that as:

$$t \rightarrow \infty \quad X(t) = 0 \quad (2.39)$$

Third situation is the underdamped case, and the following relationship characterizes it:

$$b^2 < 4km \quad (2.40)$$

The solution will have two complex roots as:

$$W_o > b \quad (2.41)$$

And if:

$$b^2 - W_o^2 = \frac{B^2}{4m^2} - \frac{k}{m} = \frac{B^2 - 4km}{4m^2} \quad (2.42)$$

then:

$$r_1, r_2 = -b \pm \sqrt{b^2 - W_o^2} \quad (2.43)$$

$$r_1, r_2 = -b \pm i\sqrt{W_o^2 - b^2} \quad (2.44)$$

$$w_1 = \sqrt{W_o^2 - b^2} \quad (2.45)$$

$$w_1^2 = W_o^2 - b^2 = \frac{k}{m} - \frac{B^2}{4m^2} = \frac{4km - B^2}{4m^2} \quad (2.46)$$

$$x_t = e^{-bt} (A \cos W_1 t + B \sin W_1 t) \quad (2.47)$$

And if it is defined:

C = as the maximum amplitude of the system

$$C = \sqrt{A^2 + B^2} \quad (2.48)$$

$$\cos \alpha = \frac{A}{C} \quad (2.49)$$

$$\sin \alpha = \frac{B}{C} \quad (2.50)$$

then:

$$x_t = e^{-bt} C \left(\frac{A}{C} \cos \omega_1 t + \frac{B}{C} \sin \omega_1 t \right) \quad (2.51)$$

$$x_t = e^{-bt} C (\cos \alpha \cdot \cos \omega_1 t + \sin \alpha \cdot \sin \omega_1 t) \quad (2.52)$$

$$x_t = e^{-bt} C \cdot \cos(\omega_1 t - \alpha) \quad (2.53)$$

This solution represents exponentially damped oscillations of the body around its equilibrium point. The graph of $X(t)$ will be located between ce^{-bt} , and, $-ce^{-bt}$.

The maximum and minimum of the curve X_t will touch them when $\omega_1 t - \alpha$ is an integral number of π .

The motion is not strictly periodic however, it is useful to call ω_1 its circular frequency, $T_1 = (2\pi)/\omega_1$ its pseudoperiod of oscillation, and Ce^{-bt} its time varying amplitude.

The damping factor in this case has three effects:

- 1)- Damps the oscillation in an exponential form with a time varying amplitude
- 2)- It slows the motion
- 3)- As an effect of the phase angle ($\omega_1 t - \alpha$), it delays the motion.

CHAPTER 3

THE MODEL

The word model comes from the Vulgar Latin *modellus*, originating from the Latin *modulus*, which means small measure. It was incorporated to the English language circa 1575 and to date it has about 13 different accepted uses, according context, some of which are:

1. A description or analogy used to help visualize something (as an atom) that cannot be directly observed.
2. A system of postulates, data, and inferences presented as a mathematical description of an entity or state of affairs.

The art of modeling is capturing the “essence” of the system intended to be described. In this way the important and determining characteristics of the system are highlighted and attention and analysis are easily focused on these elements. Omitting the details that can contribute little to describing the system also enhances the process.

For our purposes, we have developed an approximation to a dynamic spastic system incrementally beginning with a very simplified model and adding more complexity to each subsequent version of the model. [2,10, 14, 22, 23,36, 37, 38, 42, 43]

As it was explained earlier, the accepted mathematical model used for describing oscillating systems such as the pendulum, spring-mass- damping systems and some simple electrical circuits is the general second order differential equation:

$$J\ddot{\Theta} + B\dot{\Theta} + K\Theta = F(t) \quad (3.1)$$

The equation for a forced oscillating system without damping is [14]

$$m\ddot{\Theta} = -K\Theta + F(t) \quad (3.2)$$

And when we assume that there is a damping force proportional to the velocity it becomes:

$$J\ddot{\Theta} + B\dot{\Theta} + K\Theta = F(t) \quad (3.3)$$

As exposed by Bajd, Bowman and Vodovnik [38] the movement from a passive normal knee could be described by the following differential equation, implying a second order system:

$$J\ddot{\Theta} + B\dot{\Theta} + K\Theta = F(t) \quad (3.3)$$

$$J\ddot{\Theta} + B\dot{\Theta} + K\Theta = -mg l_c \sin \Theta \quad (3.4)$$

$$J\ddot{\Theta} + B\dot{\Theta} + K\Theta + mg l_c \sin \Theta = 0 \quad (3.5)$$

Which constitutes the starting point of our model.

Taking the approximation of a cylinder as a representation of the inferior limb, with an average radius and length:

$$r = 0.05\text{m.} \quad (3.6)$$

$$l = 0.53\text{m} \quad (3.7)$$

A mass and a density of:

$$m = 4.2\text{kg.} \quad (3.8)$$

$$\rho = 10^3 \text{ kg m}^{-3} \quad (3.9)$$

We will also take the normal values calculated by Bajd, Bowman and Vodovnik [38] for:

$$J = m l^2/3 \quad (3.10)$$

$$J = 0.4\text{Nms}^2 \text{ rad}^{-1} \quad (3.11)$$

For an underdamped second order system the damping ratio is:

$$\xi = \frac{B}{2(Jk)^{1/2}} \quad (3.12)$$

and the frequency ω is:

$$\omega = \omega_n (1 - \xi^2)^{1/2} \quad (3.13)$$

$$\omega_n = (K/J)^{1/2} \quad (3.14)$$

Bajd, Bowman and Vodovnik [2, 38, 39] found:

$$\xi = 0.06 \quad (3.15)$$

T= period

$$T = 1.2 \text{ sec.} \quad (3.16)$$

$$\omega = 5.23 \text{ rad. s}^{-1} \quad (3.17)$$

Since the work of Bajd and Bowman in 1982, much effort has been devoted to unraveling the meaning and implications of the Wartenberg test. As stated before, some indexes have been proposed. None of which has achieved wide applicability. Furthermore, a number of models have been created mainly from a pure mathematic point of view.

Even though nearly nothing is linear in biological systems, the accepted approach has been to settle on the linearized second order differential equation that explains the behavior of a forced underdamped oscillator. Thus:

$$J\ddot{\Theta} + B\dot{\Theta} + K\Theta + mg l_c \sin \Theta = 0 \quad (3.18)$$

For the only purpose of mathematical convenience, the equation is then linearized so it can be solved numerically. [14]

$$m\ddot{\Theta} + B\dot{\Theta} + K\Theta + mg l_c \Theta = 0 \quad (3.19)$$

One of the advantages of computer modeling is that there is no further need to use a linear model to simplify an equation. Presently, any real non-linear relationship can be solved using computer-modeling software such as Simulink (Mathworks, Natick, Ma.)

In order to describe the behavior and the altered dynamics of the Pendulum Knee Drop Test in spastic patients it is essential to adopt a non-linear approximation. In this model theta is the angle depicted by the limb as it moves from the horizontal to a vertical

position, and the sine of theta is the function, which describes the influence of gravity force on the limb. It is now believed that the muscle contraction threshold control is related, in a direct or indirect way, to the sine of theta function. Spasticity is believed to be controlled by two important parameters:

First, a value related to the sine of theta, and second its relationship to threshold that is derived from the uncoupled function of the alpha and gamma motoneurons. As a result there is an ill-controlled muscle contraction, which will deliver a great amount of energy to the system. This energy, represented as the force of the contraction, is normally intended to produce a carefully limited and regulated amount of contraction, which is translated into movement. As a consequence of this loss of control, the energy is transmitted in an uncoordinated and inadequate amount. Therefore, the muscles contract in an uncoordinated fashion that transforms the system into a non-operational, very stiff, greatly damped and highly inefficient one. Non-operational because it opposes the gravitational force and maintains a static position instead of allowing a fluid movement. Stiff because the contracted muscles will give more stabilizing energy to the joint limiting the limb excursion, and, will prevent it to move in direct proportion to the degree of spasticity, a situation that is easier to assess when the co-contraction phenomenon is present. Greatly damped because it is the only way in which a high amount of energy is delivered and is not causing any appreciable movement in the system. Consequently, energy is being absorbed and rapidly dissipated by the system. Inefficient because there is not any purpose in the release and delivering of the energy, on the contrary it hampers the expected movement.

First Model - Starting Point -: As it was outlined before, we are going to start with the simplest linear equation for an underdamped oscillation.

$$m\ddot{\Theta} + B\dot{\Theta} + K\Theta + mg \int_c \Theta = 0 \quad (3.20)$$

As a result we have the first simple model in Simulink for the Knee Drop Pendulum Test: It is a pseudoperiodic oscillator that diminishes its amplitude until it vanishes. In human subjects it last about seven seconds and have around seven oscillations before it dissipates. When applied to human inferior limb some adjustments need to be made as the force is applied at the gravity center of the leg.

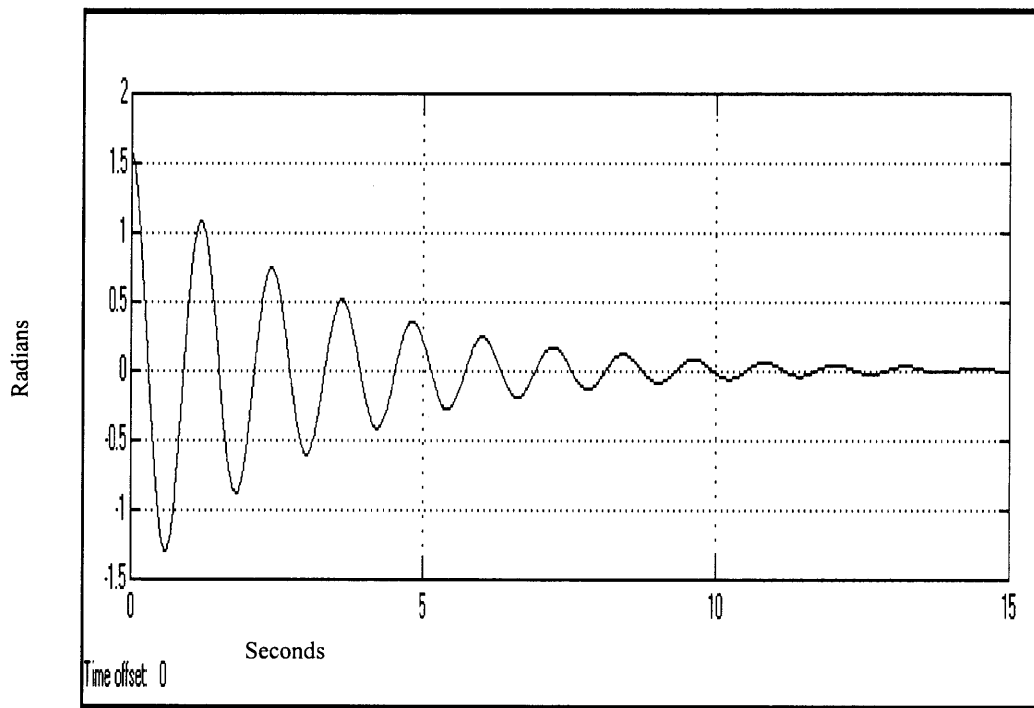

Figure 3.1. Underdamped Oscillator Second Order Linear Differential Equation

In this model, data from Vodovnik et. al. [11], were implemented as values for the simulation. Assuming the lower leg is simplified as a uniform cylinder of length l and mass m with elasticity K and viscous damping B in the joint, we have the following equation:

$$J\ddot{\Theta} + B\dot{\Theta} + K\Theta + \frac{1}{2}mg \int_c \sin \Theta = 0 \quad (3.21)$$

Where J is the moment of inertia. When linearized it becomes:

$$J\ddot{\Theta} + B\dot{\Theta} + K\Theta + \frac{1}{2}mg \int_c \Theta = 0 \quad (3.22)$$

Instead of dividing the length of the limb in half in order to calculate the center of gravity, it was decided to divide the gravity in half, in this way any time a new simulation is done with different values extra calculations are avoided; yet the relation is preserved.

$\ddot{\Theta}$ is isolated as an starting point for the model:

$$J\ddot{\Theta} = -B\dot{\Theta} - K\Theta - \frac{1}{2}mgl\Theta \quad (3.23)$$

$$\ddot{\Theta} = 1/J(-B\dot{\Theta} - K\Theta - \frac{1}{2}mgl\Theta) \quad (3.24)$$

Notice the negative value of $-\frac{1}{2}mgl\Theta$, which implies a negative direction of the limb movement when influenced by gravity.

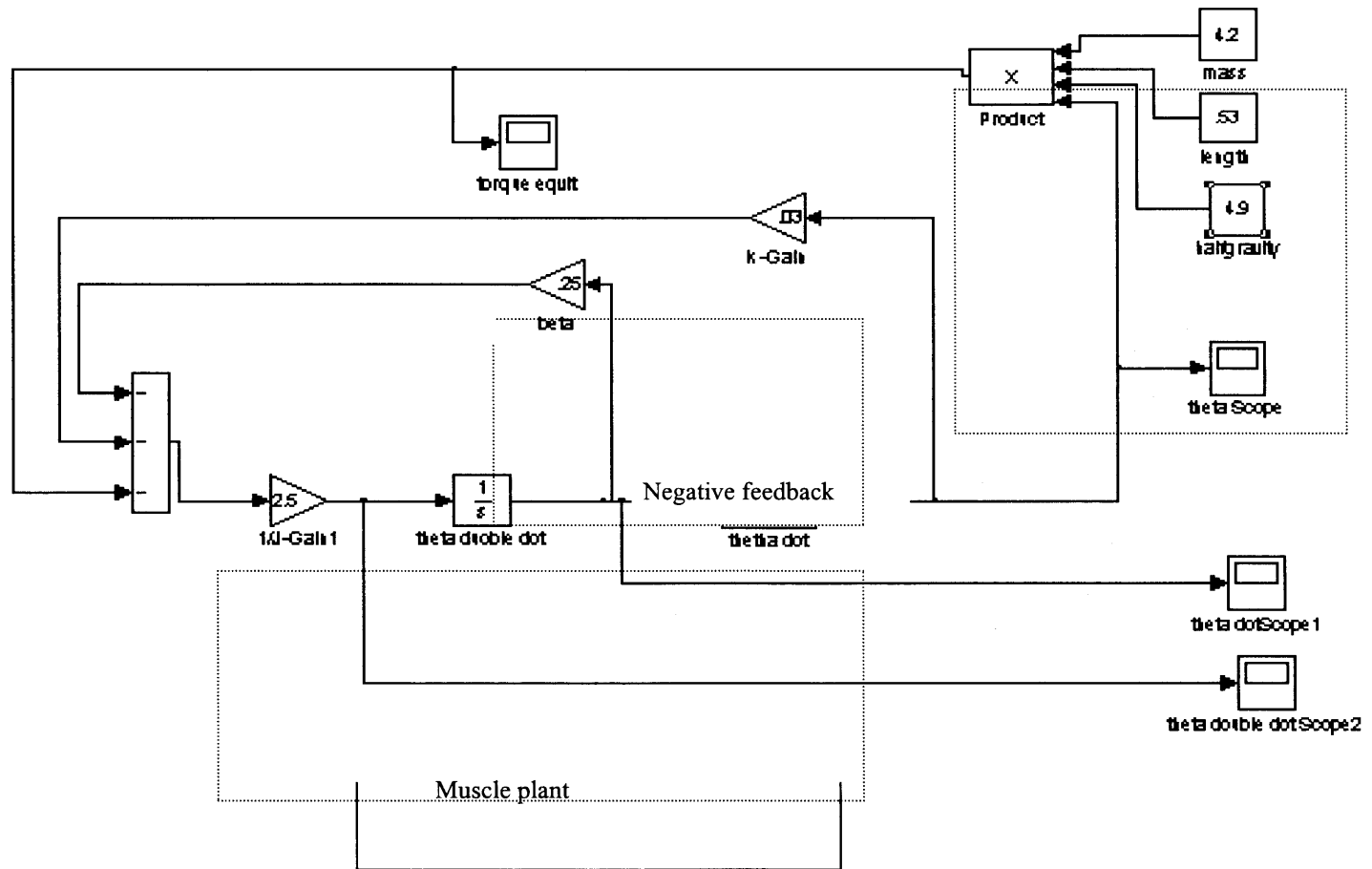

Figure 3.2. First Model -Starting Point -

Second Model- Non linear Gravitational Force –The primary advantage of Simulink modeling is the ease of adding non linear elements. Thus the gravitational excitation proportional to the sine of theta is added.

$$J\ddot{\Theta} + B\dot{\Theta} + K\Theta + \frac{1}{2}mg l_c \sin \Theta = 0 \quad (3.25)$$

There is not a large change in the response of the system model in Simulink for the Knee Drop Pendulum Test: It is still a pseudoperiodic oscillator that diminishes its amplitude until it vanishes. The period itself has varied becoming a slightly longer, than in the previous model.

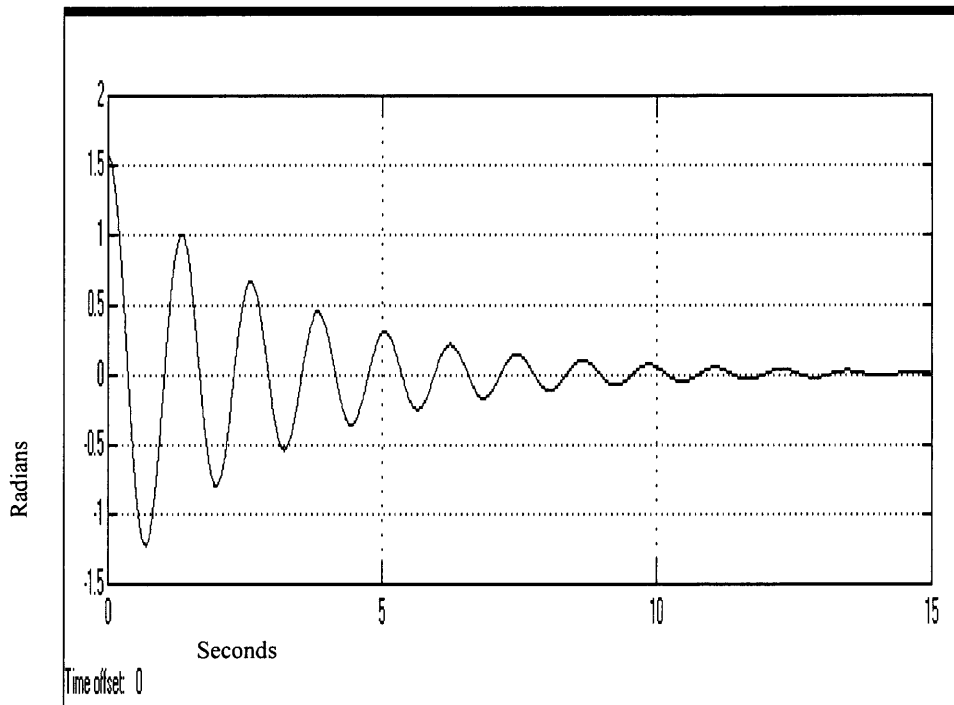

Figure 3.3. Underdamped Oscillator -Position-Second Order Differential Equation (sine function)

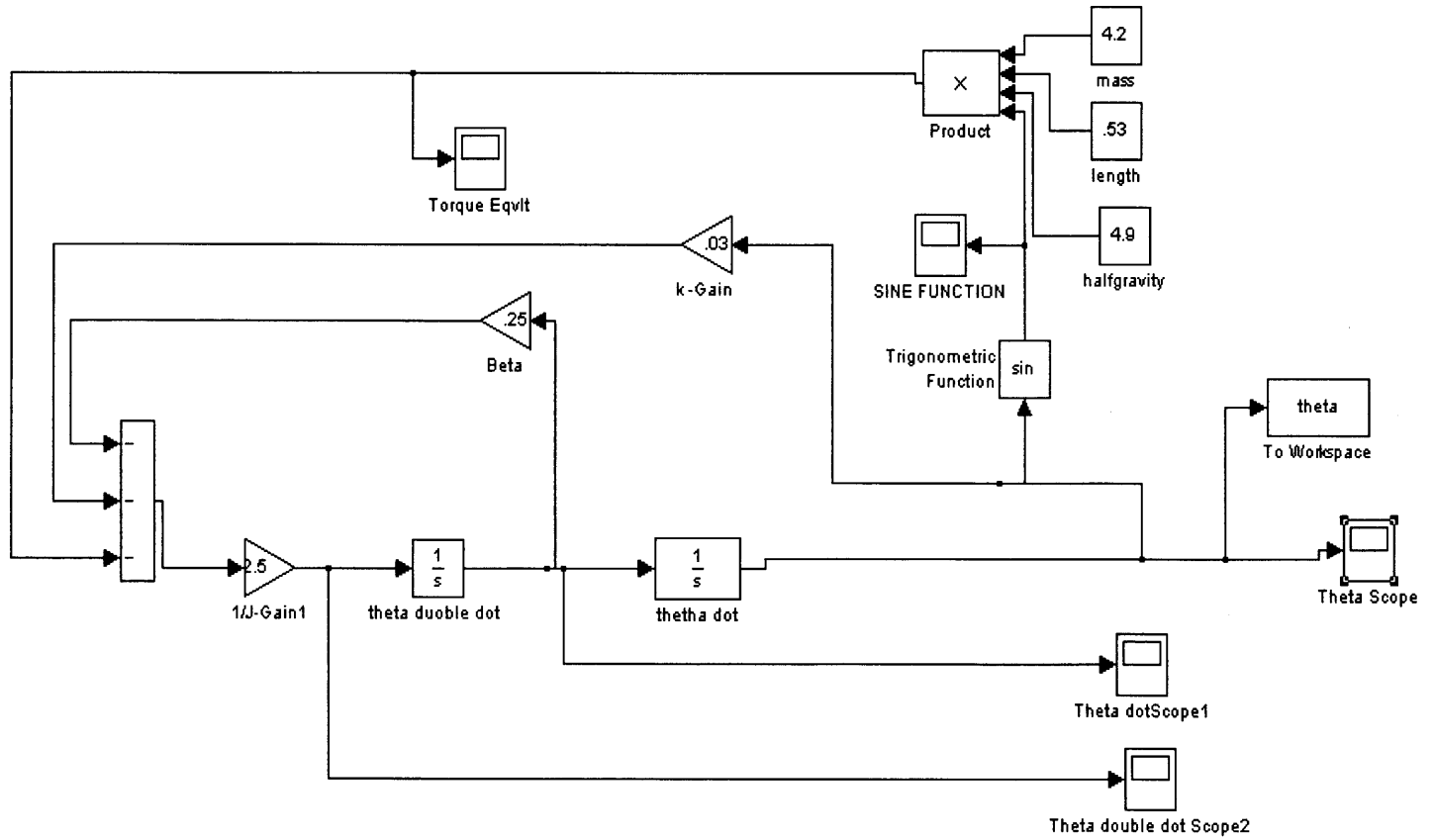

Figure 3.4. Second Model -Sine Function -

Third Model – Muscle Contribution: A very significant component of the definition of spasticity is the sudden appearance of a muscle contraction; up to the present only related to a certain type of “velocity dependent” threshold, which reflects a hyperexcitability of the stretch reflex. In order to model spasticity it is necessary to represent this sudden muscle contraction, or better to represent the effect that this muscle contraction produces on the dynamics of the system.

When the muscle contracts it provides certain force to the limb, which is multiplied by the lever arm producing a torque. The distance of this lever arm is measured from the location where the muscle is inserted in the bone to the pivot of the joint. Adding an extra torque to the equation characterizes the muscle contraction. The next important determination is to provide the adequate value of magnitude, and a way of modeling the appropriate onset and duration for this torque.

Initially, we will be able to manually set the proper timing and magnitude of the torque. We model it as set of two separate step functions acting together. A step function turning it on and then another step function turning off. According to the work done by Fee and Foulds, and by Rymer et. al. the best moment to include this stimulus is at approximately 330 mseconds after the onset of the exam. Their studies show that this coincides with the onset of the EMG signal, which indicates the beginning of the spasm muscle contraction. Rymer’s studies indicate that the value for this torque should not exceed 30 N-m and is usually lower with a value of about 10 N-m. [13, 22]

In this model we also incorporated a manual switch in order to be able to activate and deactivate the muscle torque. This is done by multiplying the torque by one (position “on”) or by zero (position “off”) as needed.

Our model includes a number of Simulink scopes graphical outputs in order to observe the effect of each model block. As a result, we are able to appreciate what is the contribution of each model segment. The influence of added torque on the system is best shown by the acceleration. This is included in each simulation. In the following set of graphs the response display remains unchanged, from a pendular trajectory as additional muscle torque, has not yet been added.

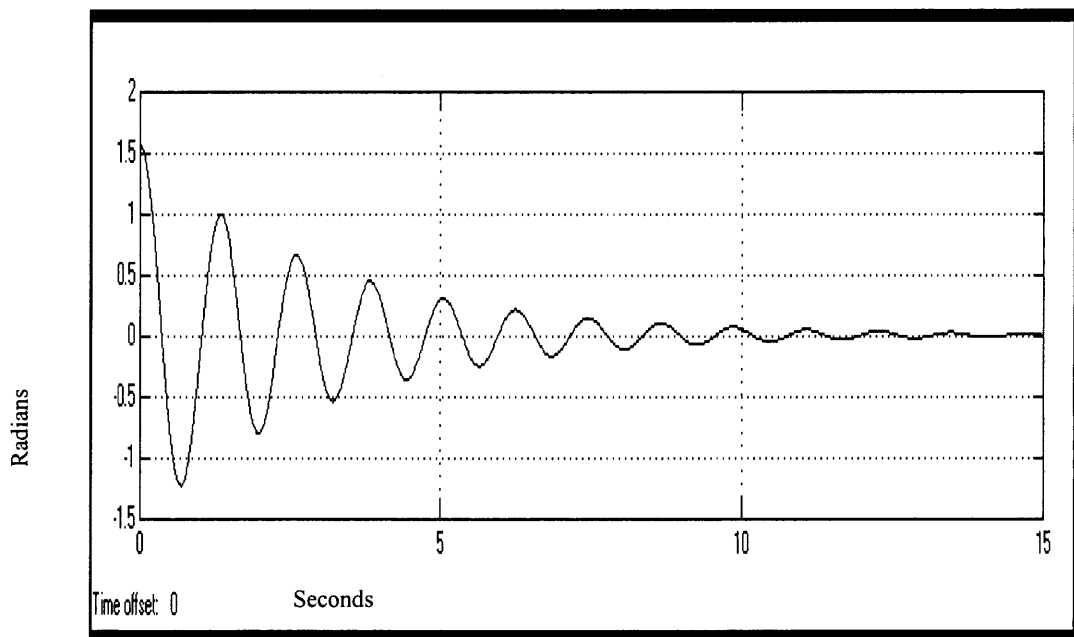

Figure 3.5. Underdamped Oscillator-Position-Second Order Differential Equation
(muscle contribution-switch OFF)

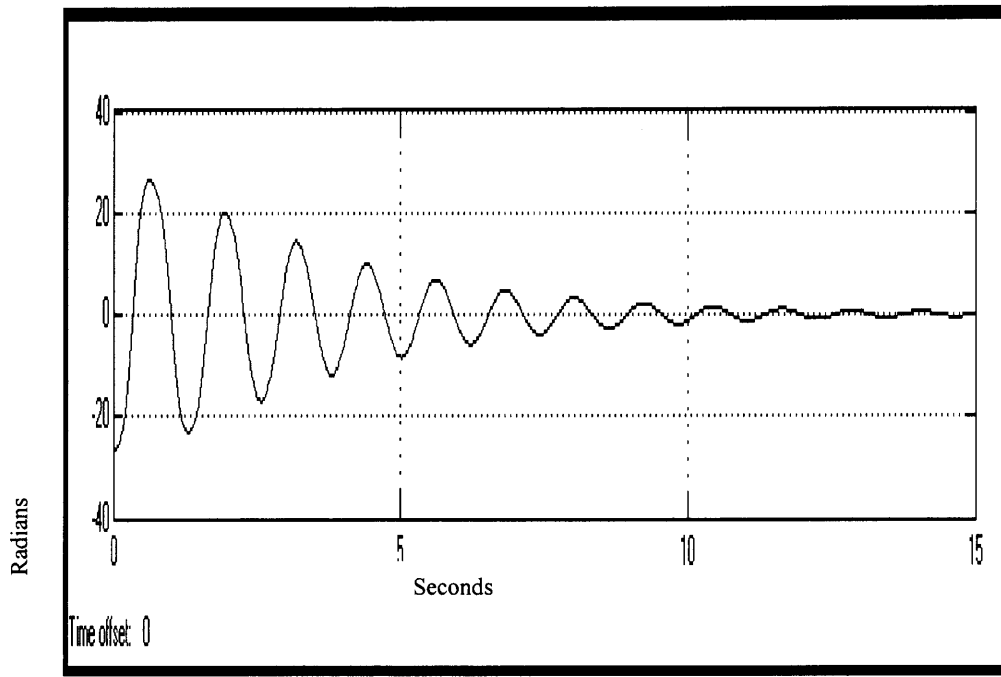

Figure 3.6. Underdamped Oscillator -Acceleration- Second Order Differential Equation (muscle contribution-switch OFF)

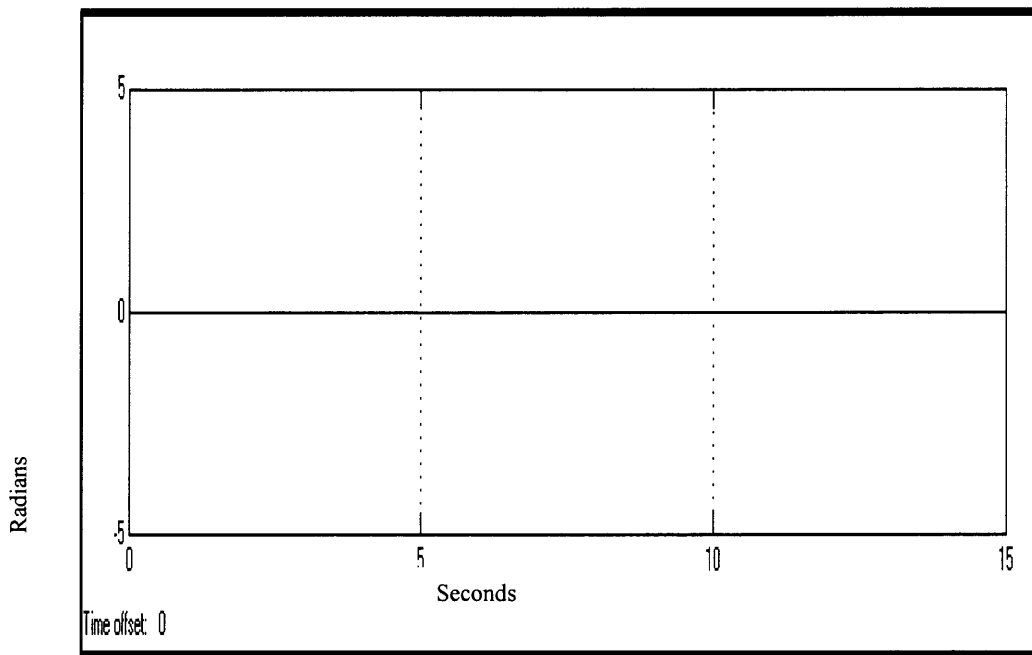

Figure 3.7. Torque Contribution- (muscle contribution-switch OFF)

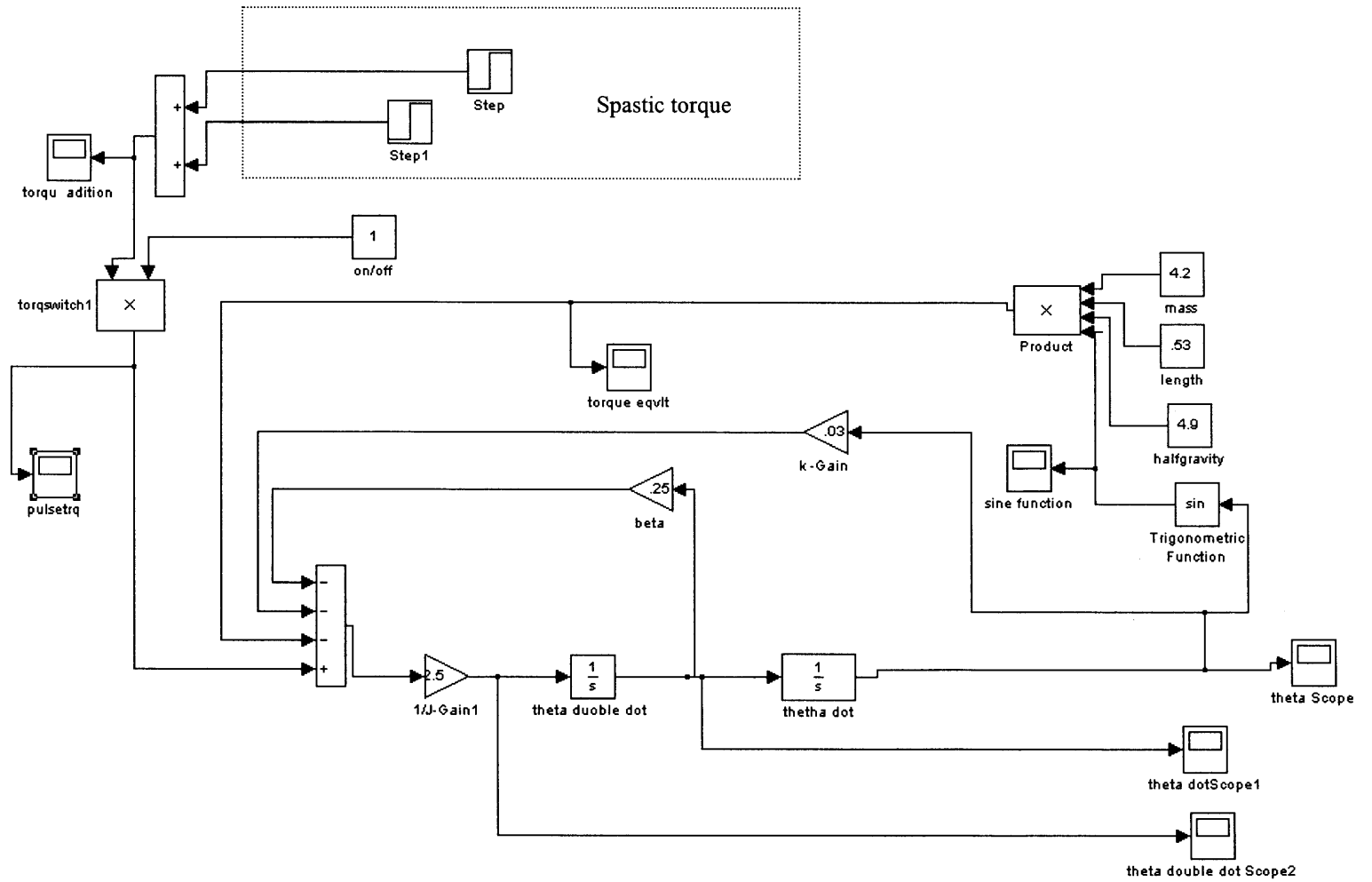

Figure 3.8. Third Model - Muscle

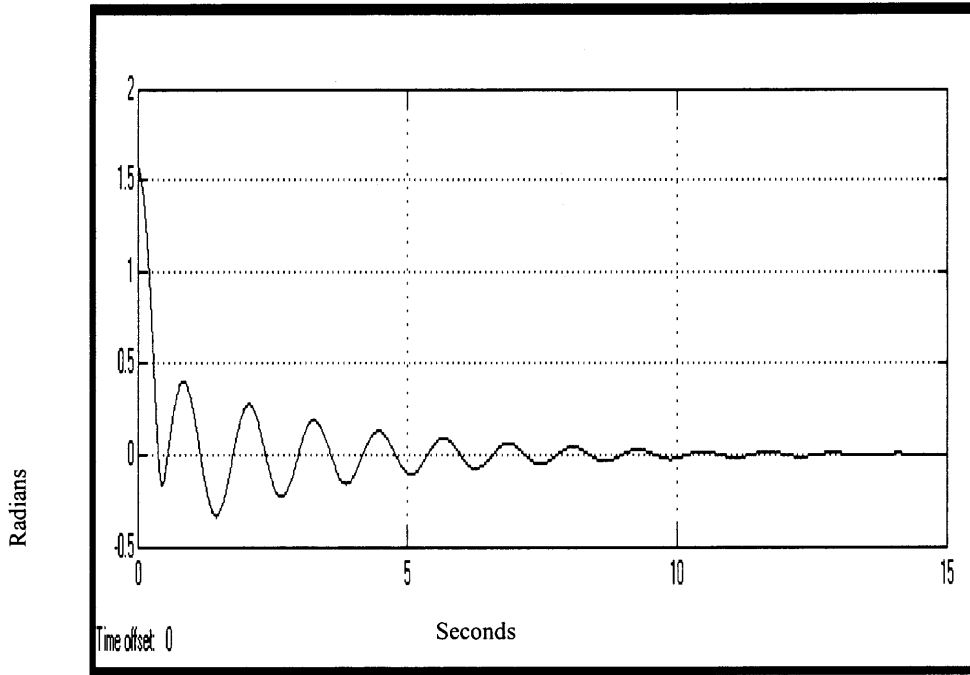

Figure 3.9. Underdamped Oscillator-Position-Second Order Differential Equation (muscle contribution-switch ON)

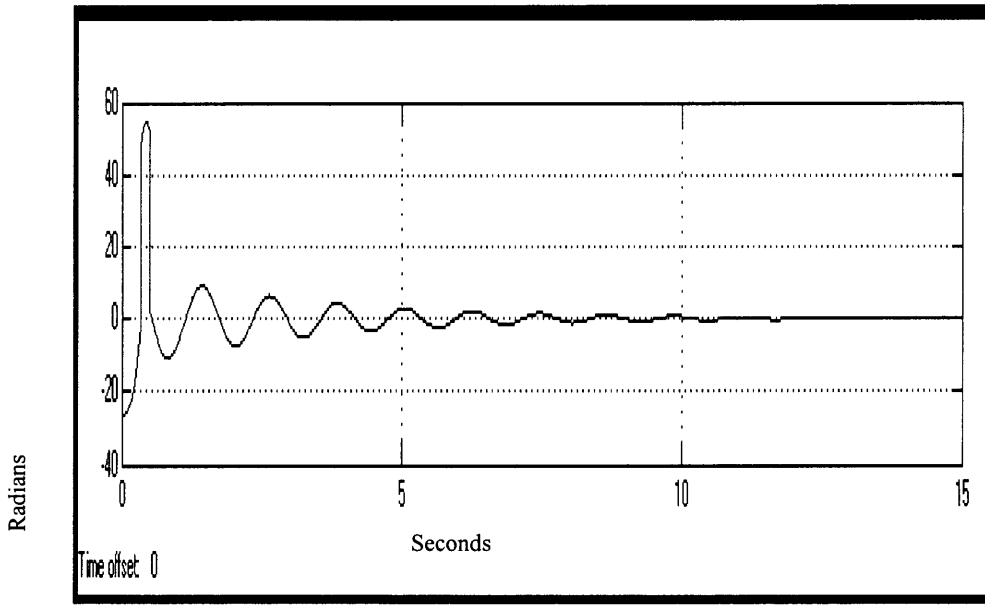

Figure 3.10. Underdamped Oscillator -Acceleration- Second Order Differential Equation (muscle contribution-switch ON)

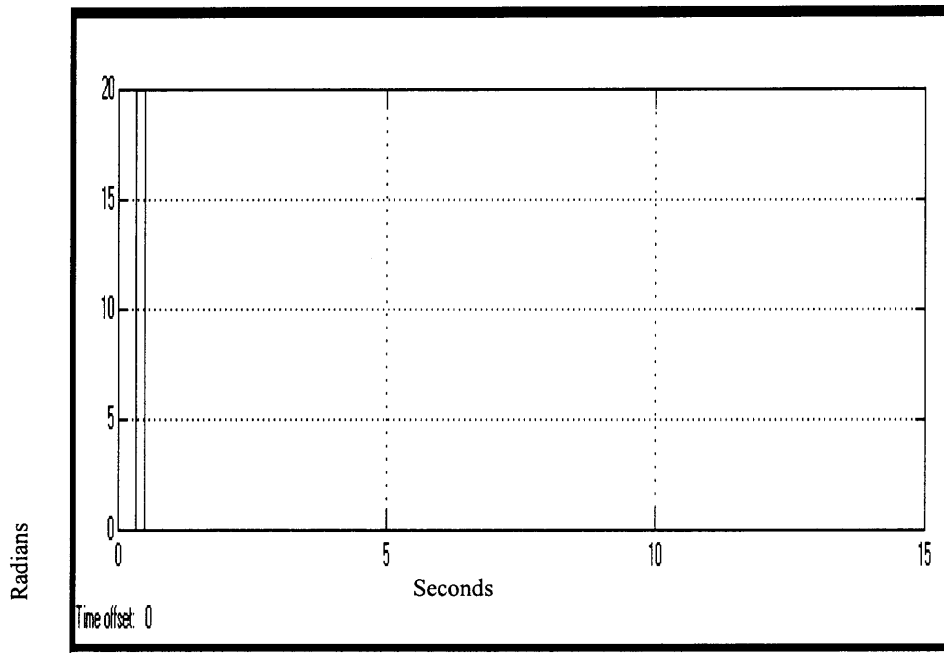

Figure 3.11. Spasm Torque Contribution- (muscle contribution-switch ON)

The first set of figures (Figures # 3.5., 3.6., 3.7.) shows a normal Pendulum Knee Drop Test response produced by the model. The second set of figures (Figures # 3.9., 3.10., 3.11.) shows a simulated abnormal Pendulum Knee Drop Test. These figures represent a mildly spastic patient who just had one solitary muscle contraction of the quadriceps.

Notice the changes introduced in the response from the position (theta angle), acceleration (theta double-dot) and the torque produced by the muscle contraction, from the addition of a single torque of 20 Newtons with a short duration of 170 milliseconds.

A very important concept will be introduced in the next in order to provide a better pathophysiological dimension.

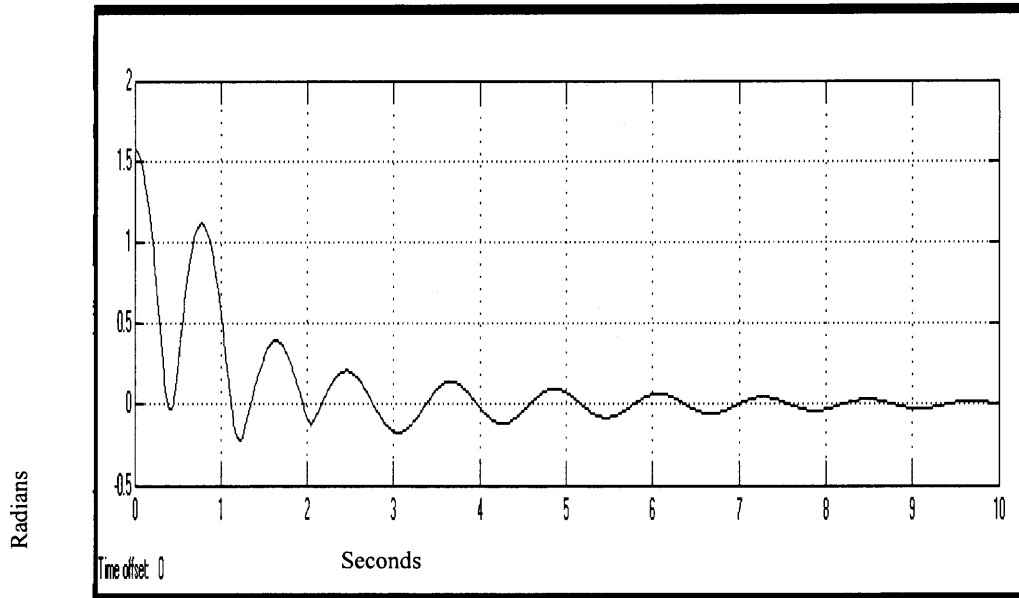

Figure 3.12. Underdamped Oscillator -Position-Second Order Diff. Equation (multiple muscle contribution-switch ON)

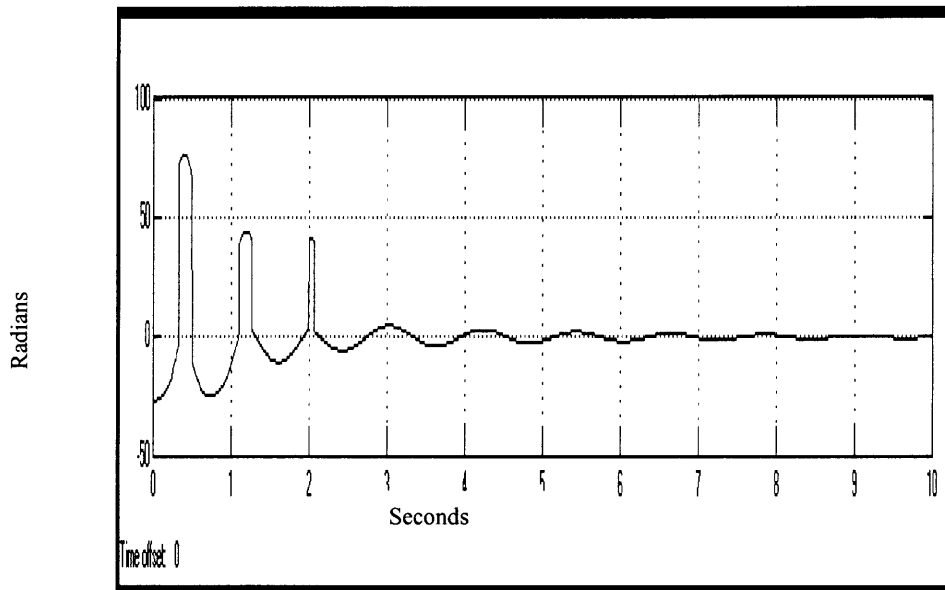

Figure 3.13. Underdamped Oscillator -Acceleration-Second Order Diff. Equation (multiple muscle contribution-switch ON)

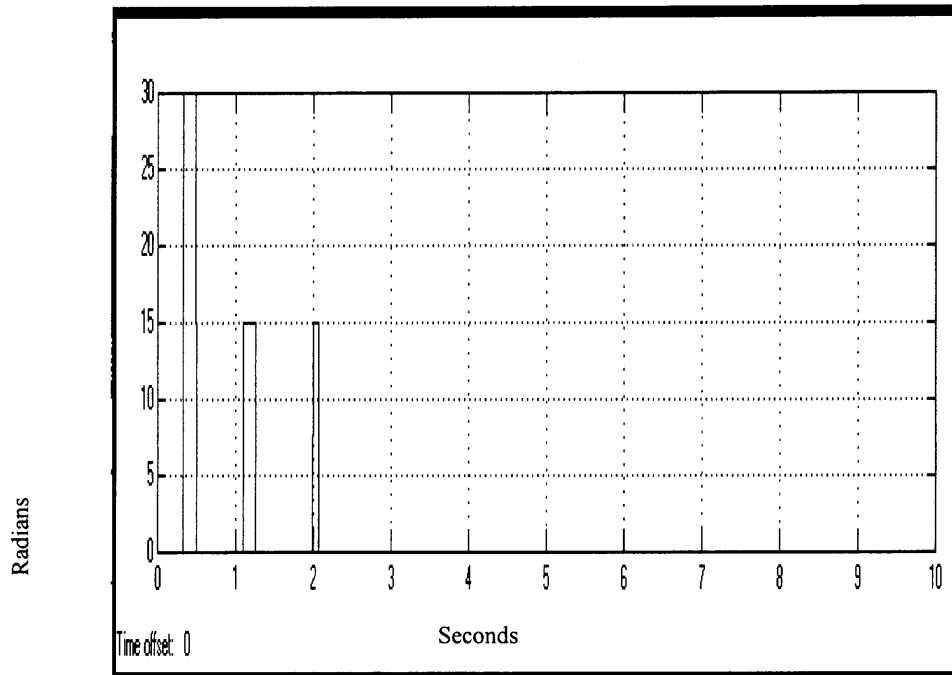

Figure 3.14. Torque Contribution (Multiple muscle contribution-switch ON)

This particular model was found to be very useful in understanding the dynamics of the model by introducing, in piecewise fashion, a series of torques, and analyzing their effect. As can be anticipated, the additional torque will reach a point at which a progressive intensity of force will drive the system to an unstable situation. On the contrary if the magnitude of the force is progressively diminished it will continue damping the system. When constant value of torque is applied the system tends to find an equilibrium point different from the gravitational vertical.

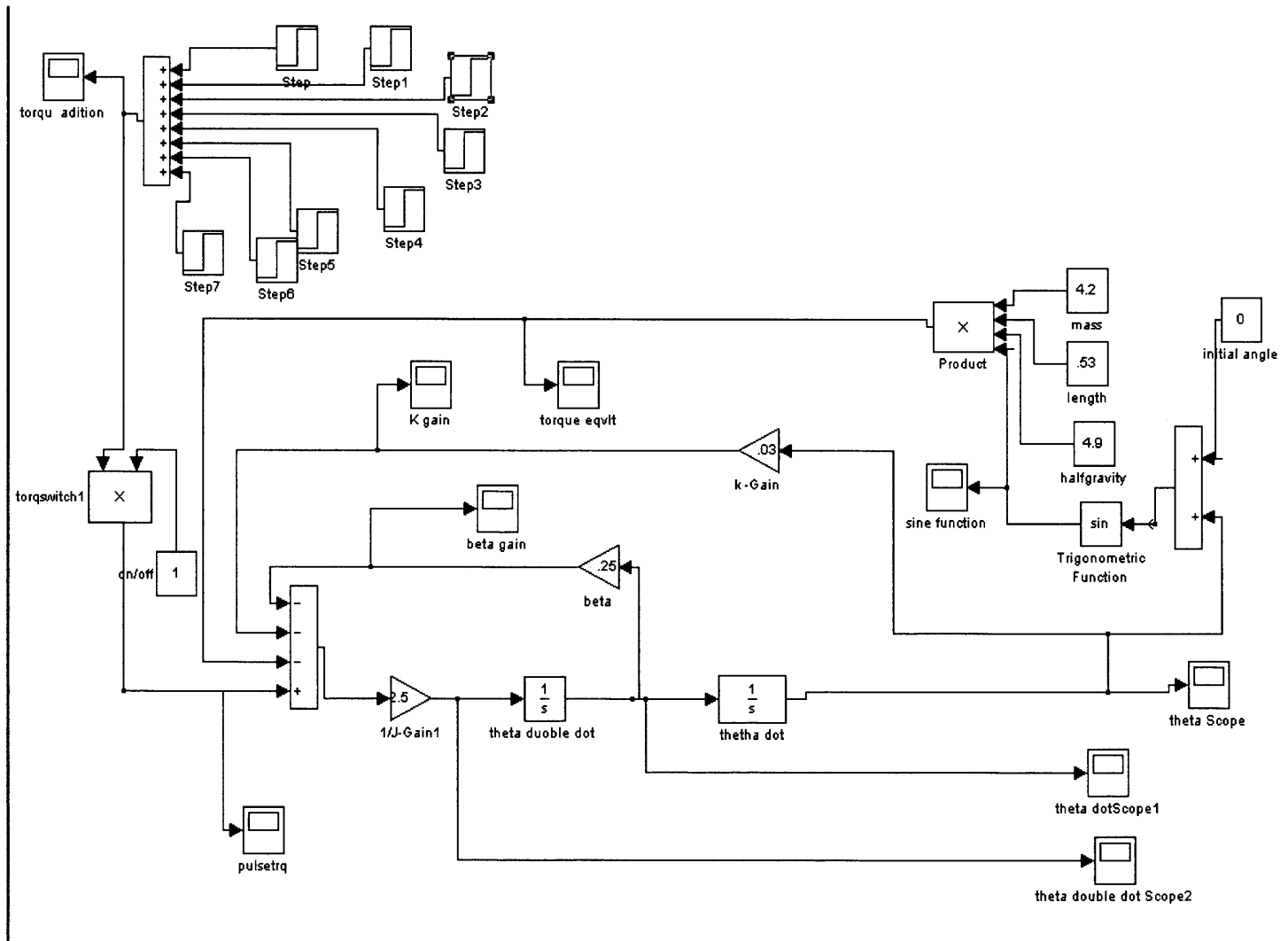

Figure 3.15. Third Models - Multiple Muscle Contribution-

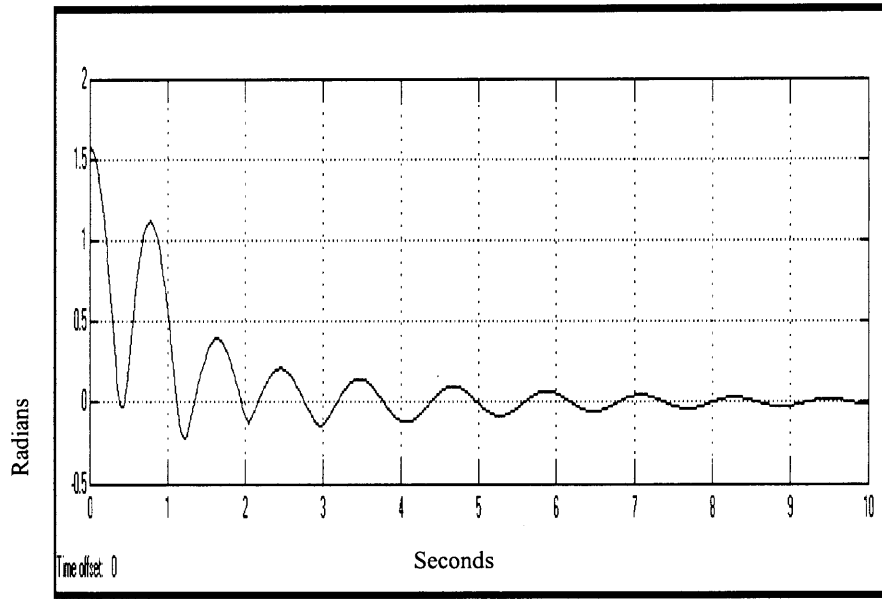

Figure 3.16. Underdamped Oscillator -Position-Second Order Diff. Equation (multiple muscle contribution-switch ON)

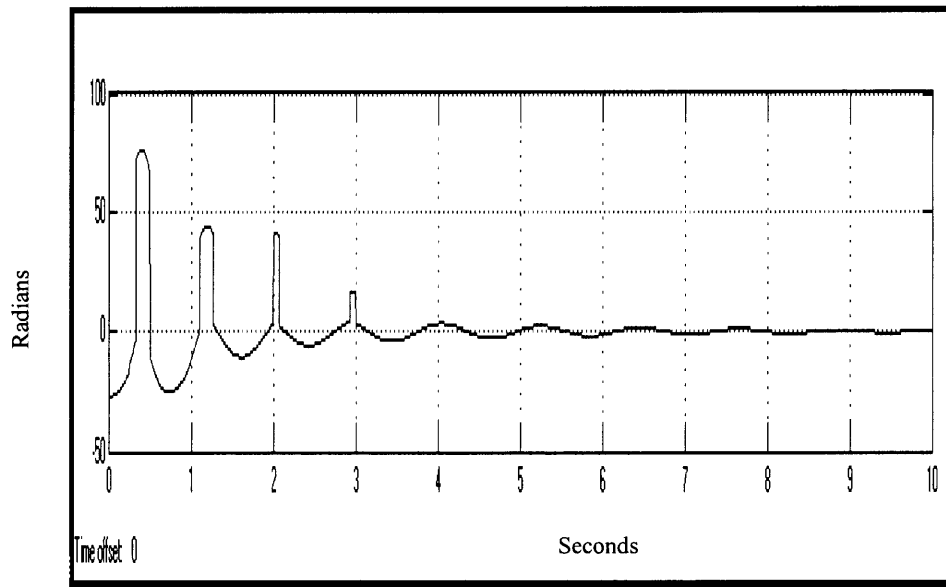

Figure 3.17. Underdamped Oscillator -Acceleration-Second Order Diff. Equation (multiple muscle contribution-switch ON)

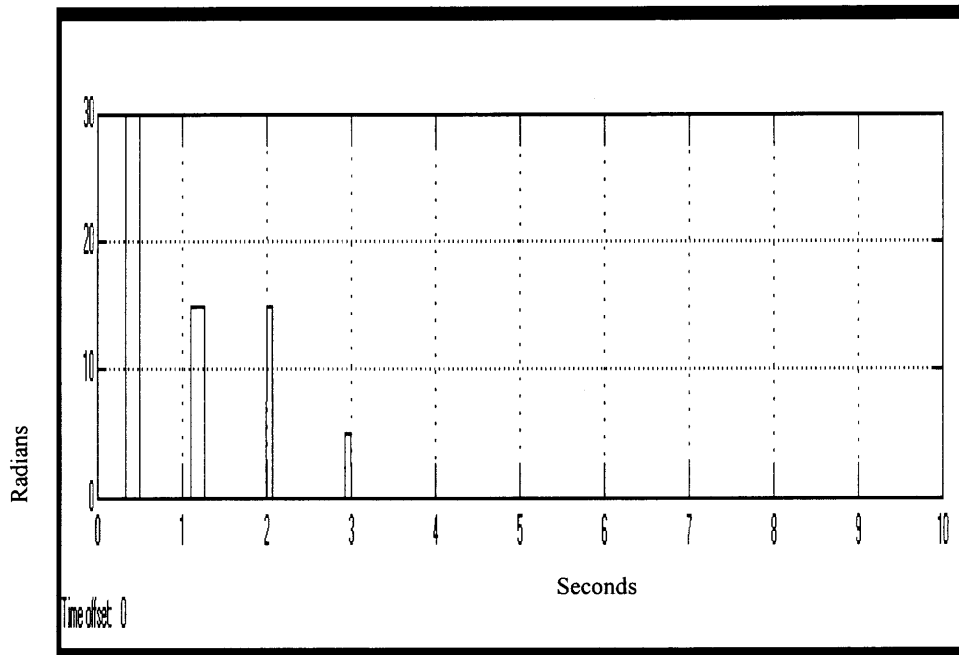

Figure 3.18. Torque Contribution (Multiple muscle contribution-switch ON)

Fourth Model - On/off switch. : Feldman introduced a very important concept, the Lambda theory, which is now being slowly accepted by the experts. The essence of the Lambda theory states that the activating feature does not depend exclusively on a fixed value, but on a floating and resettable value. This theory might be explained by the fact that the lost regulation of the stretch reflex, from the suprasegmental levels, produces a different effect in the alpha and gamma motoneurons of the ventral horn in the spinal cord. These changes mainly disturb the involuntary portion of the regulation of the stretch reflex, the gamma motoneuron system. Thus it a model was created that uses a function to trigger the spastic torque input

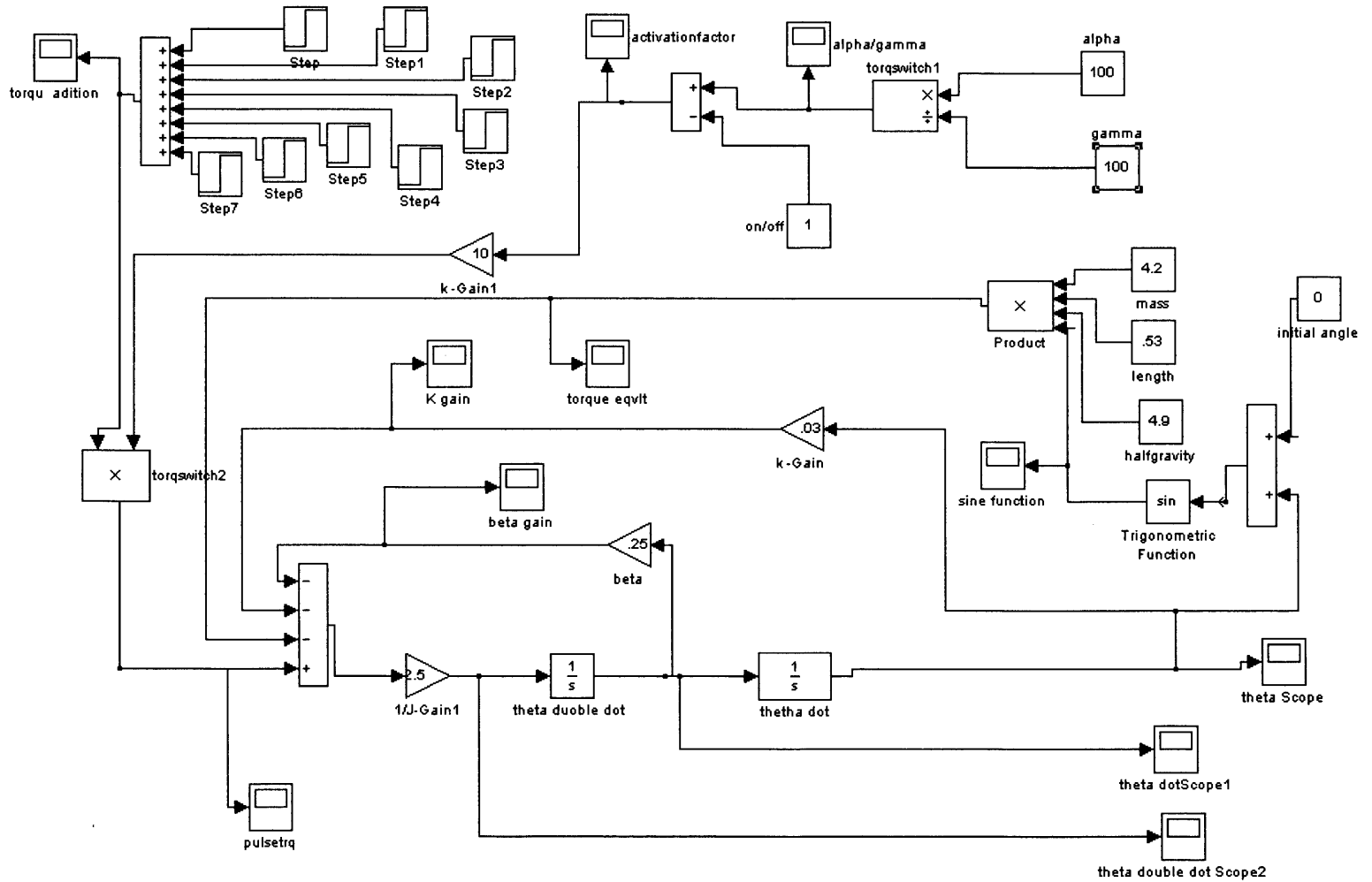

Figure 3.19. Fourth Model – Switch ON/OFF

In this model a difference in CNS alpha and gamma signals switches on and off the contribution that represents the spastic contraction.

Arbitrarily we set both alpha and gamma initially as 100%. Hence, their ratio will render an absolute value of 1. Subsequently, it can be altered as needed to observe the effect of this variation on the system. Gamma was the variable chosen to be altered. In this way as the denominator diminishes the fraction will grow, and after it is subtracted from a unit, we will find the Activating Factor (AF). Again, this AF (Activating Factor) will vary in a non linear way.

As stated above, the maximum accepted value for a quadriceps torque is of thirty Newtons (30 N-m); therefore we will limit it to this value in this model with a saturation block. Also a sustained final contraction (S F C) is simulated, as it will occur in a severely spastic patient with a constant delivered anti-gravity torque.

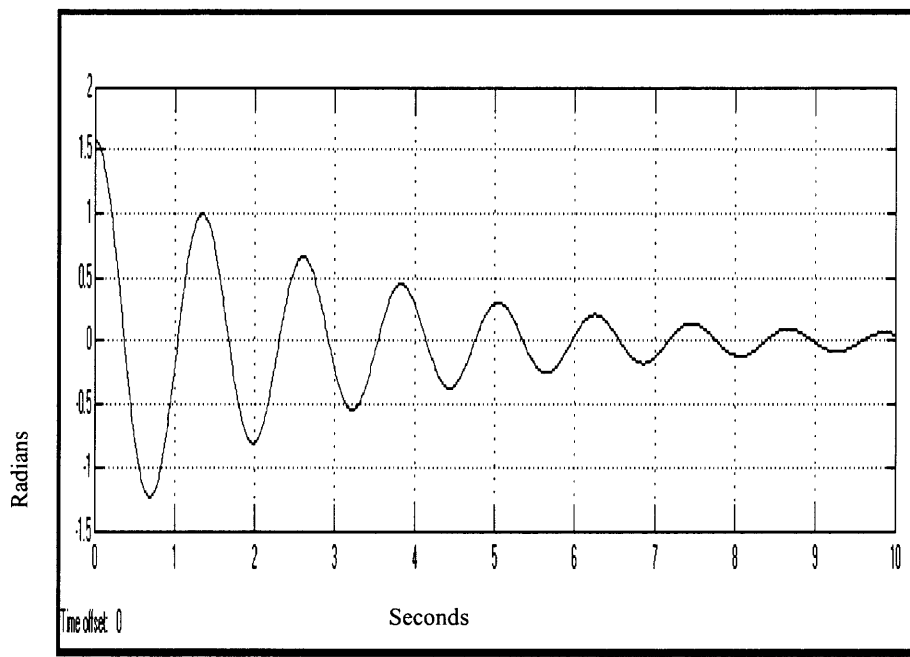

Figure 3.20. Switch On/Off (Switch Off)- Position-

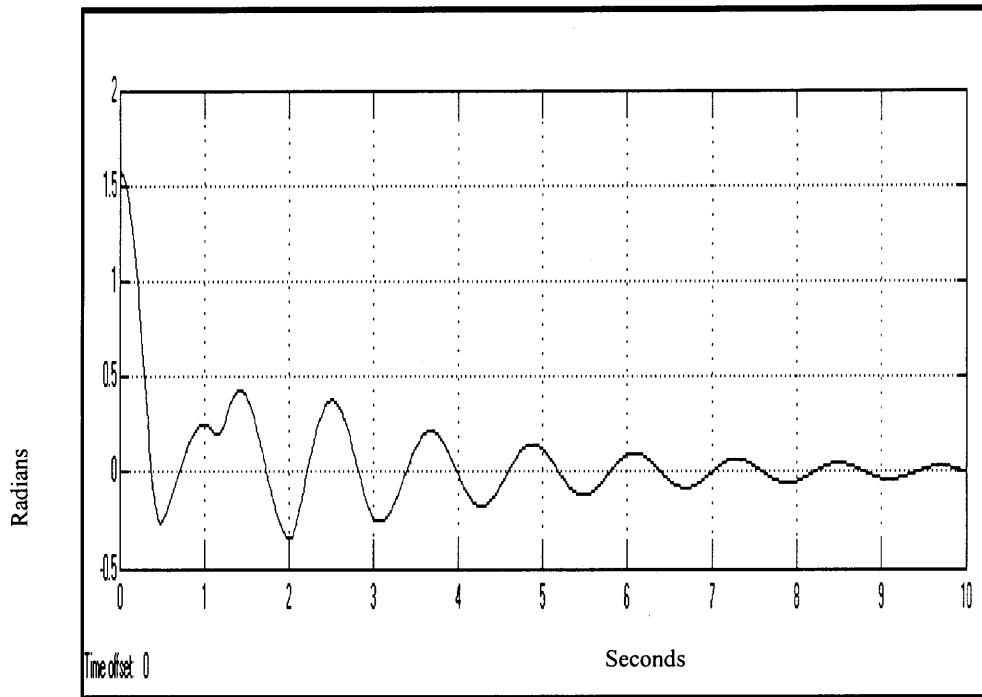

Figure 3.21. Switch On/Off (Switch On)- Position-

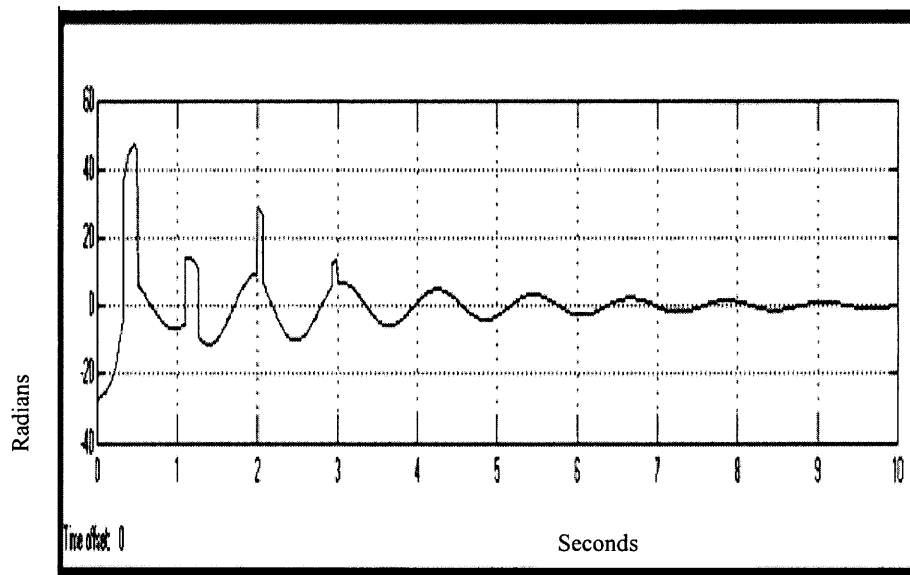

Figure 3.22. Switch On/Off (Switch On)- Acceleration-

As it is easy to appreciate that the muscle contribution, when activated by the switch on/off alpha /gamma variable, also creates a pattern of exaggerated damping. What is interesting to appreciate is that it is the relationship between the different torque and damping oscillations, not their absolute values that will produce the desired effect.

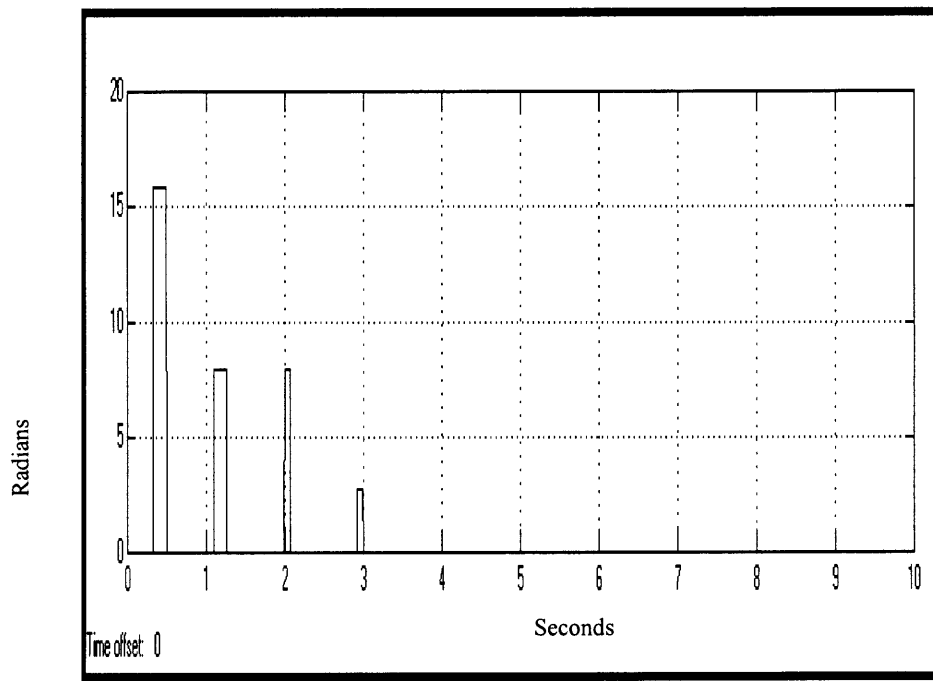

Figure 3.23. Switch On/Off (Switch On)- Muscle Torque –

The next illustration corresponds to a switch activated simulation, but in this case the last contraction is allowed to continue as permanent. The net effect produced, is a new setting for a new equilibrium value. In patients, this corresponds to the cocontraction phenomena that produce a final equilibrium point that is different from gravitational neutral.

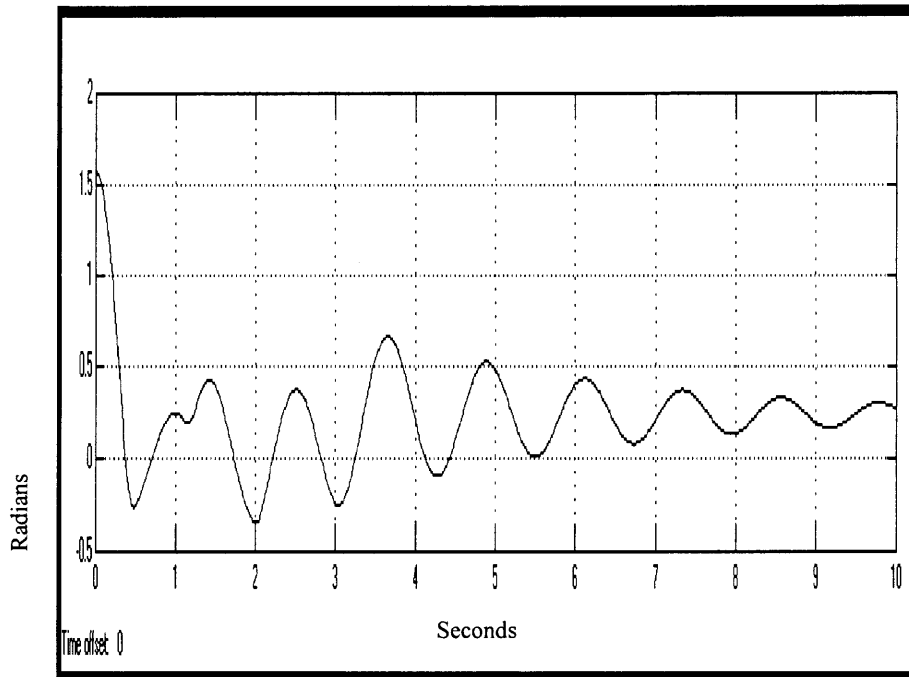

Figure 3.24. Switch On/Off (Switch On Permanent End)-Position-

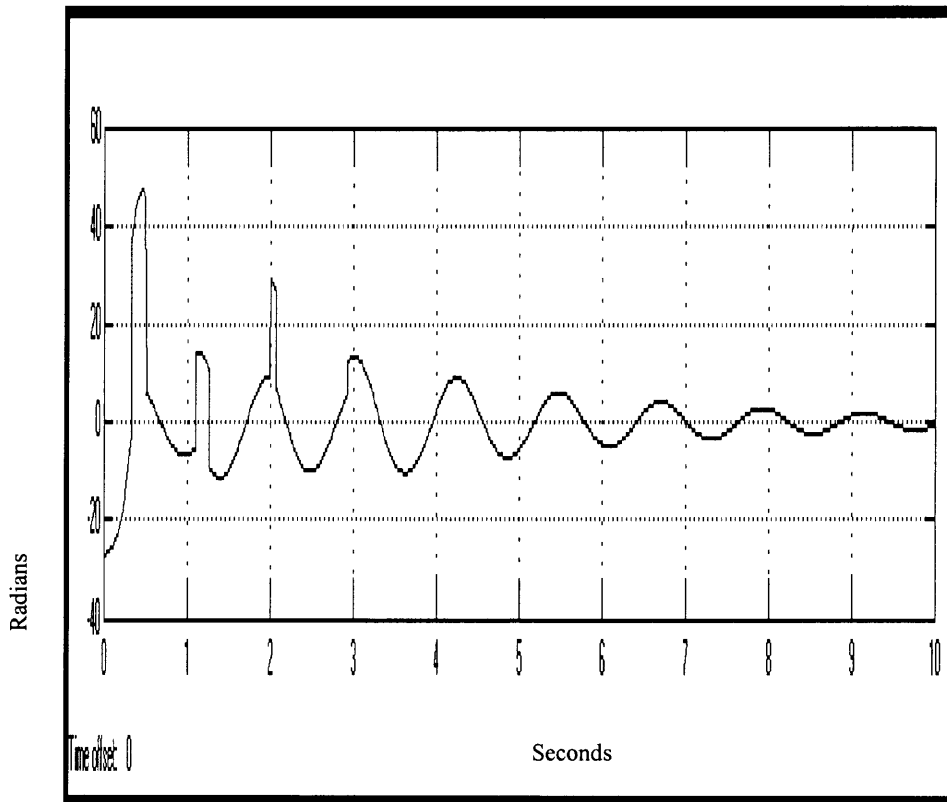

Figure 3.25. Switch On/Off (Switch On-Permanent End)-Acceleration

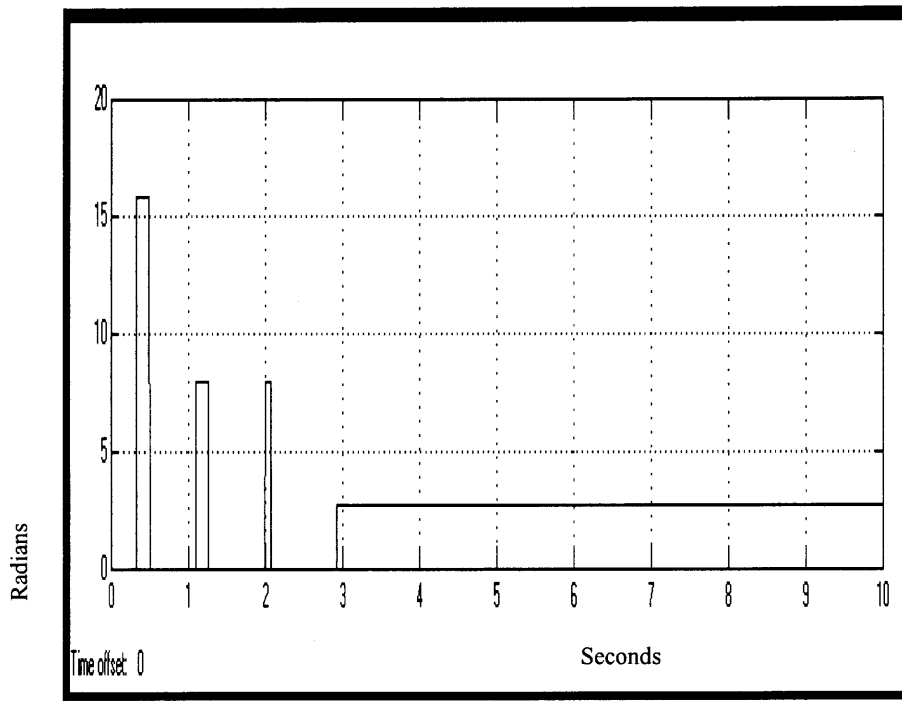

Figure 3.26. Switch On/Off (Switch On-Permanent End)— Muscular Torque

Still there is a difference with the curve obtained from patients. In this model the final damping is less effective than in patients that change their final resting point. It is believed that this could be explained by the fact that in permanent contraction, the Actin and Myosin interaction will increase the damping coefficient (B). The difference in density between two different liquids is explained by the amount of attraction between their molecules. The molecules of a dense liquid interact attracting themselves much more. In a similar way the more existing binding sites between Actin and Myosin will act as a more damping type of muscle. So now it is incorporated a damping increasing function, as a function of time.

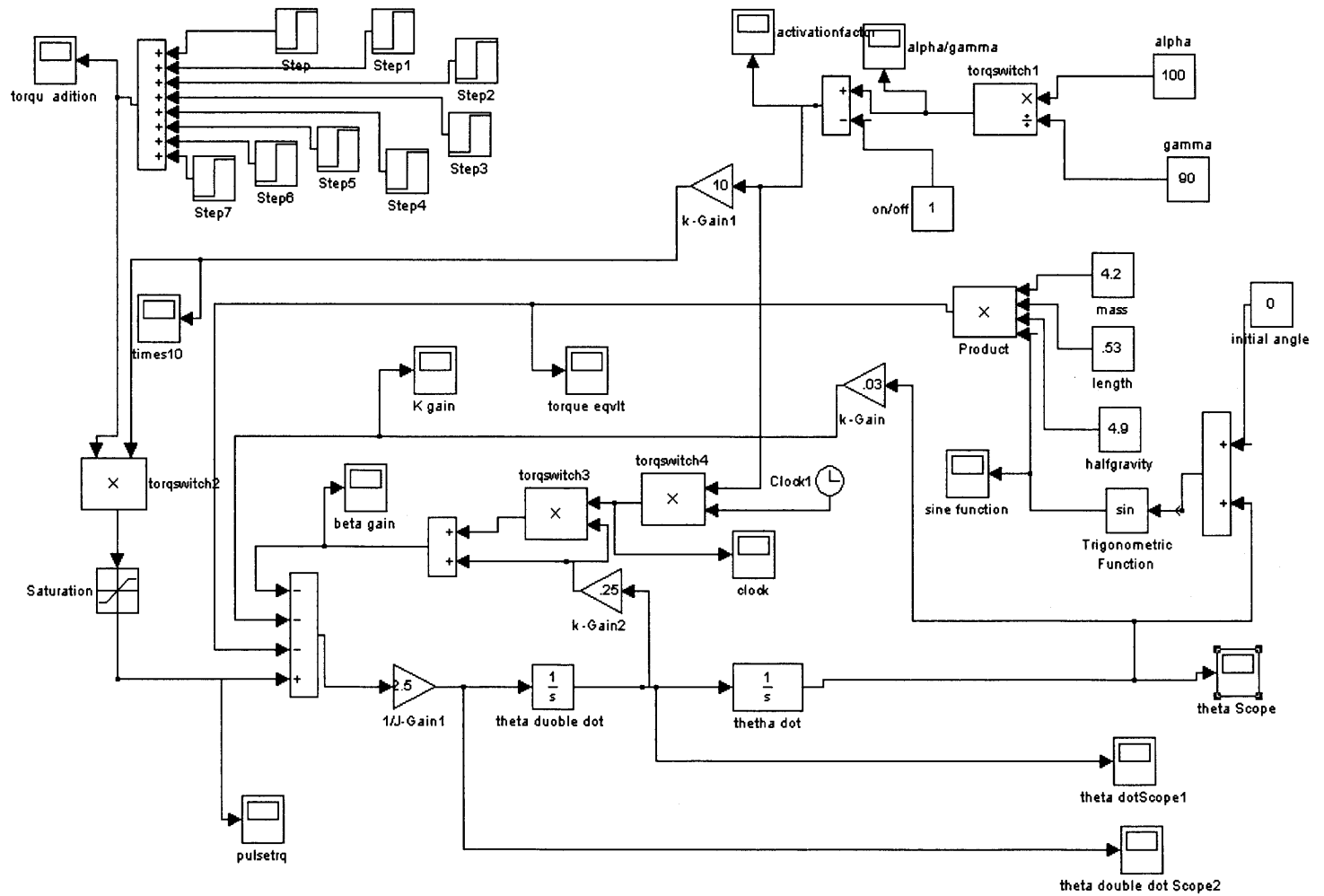

Figure 3.27. Fourth Model – Switch ON/OFF (increasing Damping Coefficient)

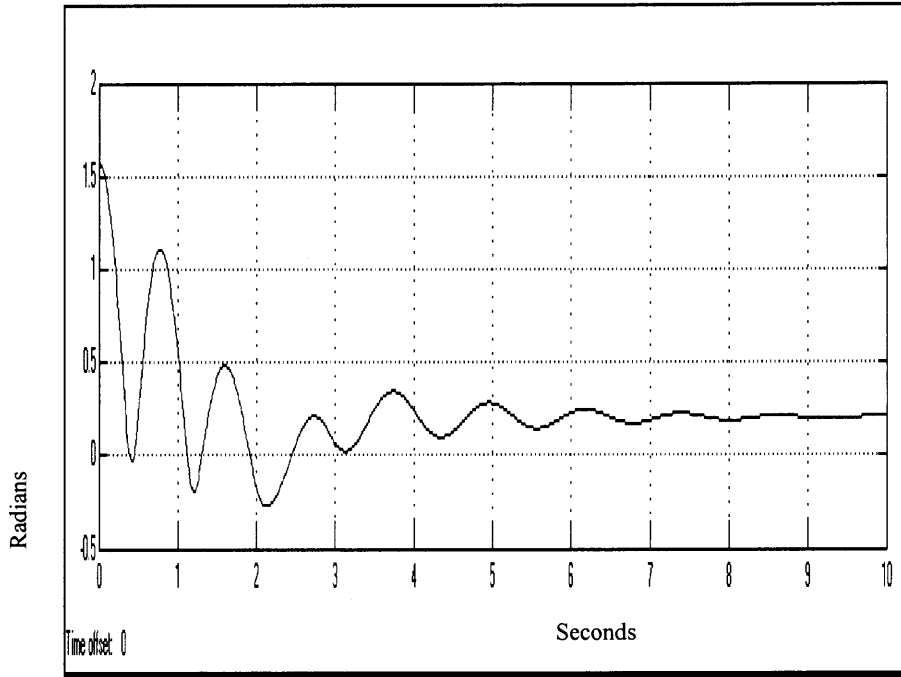

Figure 3.28. Switch On/Off (Increasing Damping Coefficient)-Position

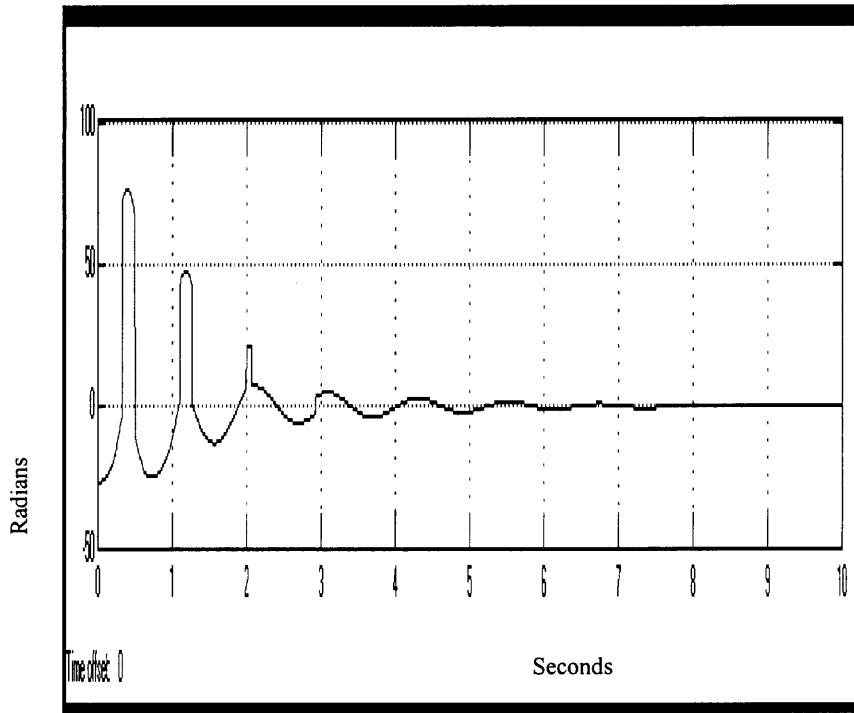

Figure 3.29. Switch On/Off (Increasing Damping Coefficient)-Acceleration-

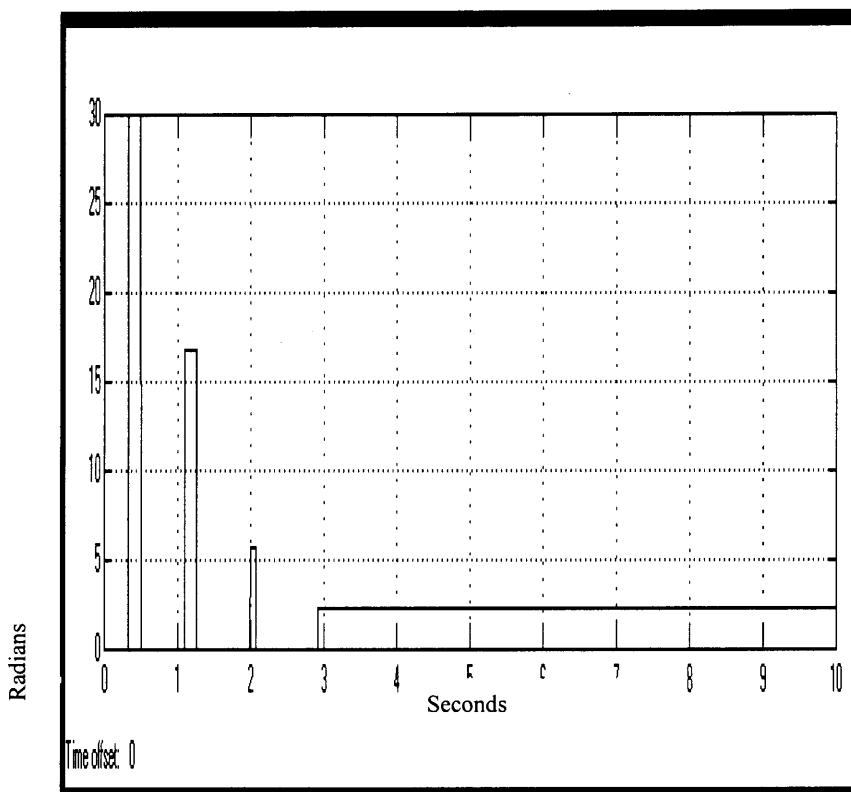

Figure 3.30. Switch On/Off (Increasing Damping Coefficient)-Torque

As shown, this particular model, once understood, allows one to implement and analyze the torques needed to transform the “normal” underdamped oscillation into any trajectory position of the spastic subjects.

It is very important to note that the best torque amplitude combination depicts a fall along a gradually diminishing curve. This torque-diminishing curve represents an exponential time dependent curve.

Before the introduction of the exponential time dependent exponential curve to the model it is necessary to consider a special case. The case of severe spastic patient. A severe spastic patient requires a detailed and independent analysis. This type of patient exhibits a very different behavior. Characteristically they cannot achieve a complete relaxation. Therefore, these patients present contracture of the muscles at the beginning

and through the entire pendulum test. Their movement is very limited, the spastic energy is very high and the resting point is shifted from the usual position.

An adequate way of representing these patients is a permanent torque throughout the range of motion of it. The trajectory will find a new equilibrium point, usually very near the starting position.

The fact that the muscle is permanently contracted will enhance the amount of stiffness of the joint. In a similar way, as will happen when two tensors, at opposite ends of a rod, are highly tensed. Also, the damping coefficient will increase with the amount of interaction between the molecules of Actin and Myosin. This appears as if was dispensed inside the damper or damping chamber. The main difference between the two liquids, with dissimilar densities, is that the amount of inter-molecular attraction is larger in the one with highest density. Therefore, if the amount of interaction between Actin and Myosin is higher, when the muscle is contracted, the muscle will behave as having a higher damping coefficient.

For this specific simulation we will assume: first, permanent muscle contraction, since the beginning, which means a permanent torque. Second, an increasing damping and spring coefficients as time of the exam progress. The result is an overall change from an underdamped type to a critically damped or an overdamped type of behavior.

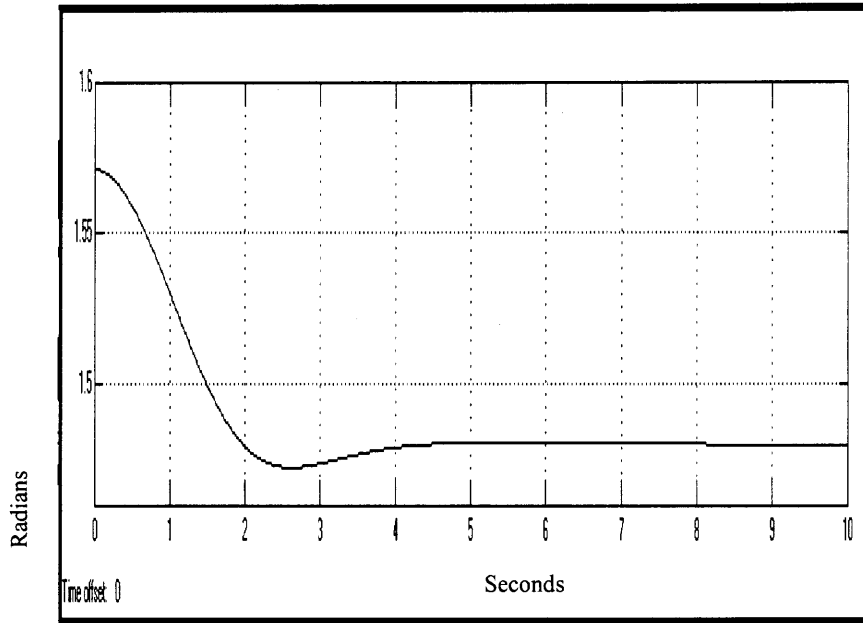

Figure 3.31. Severe Spasticity (Permanent Contraction)– Position

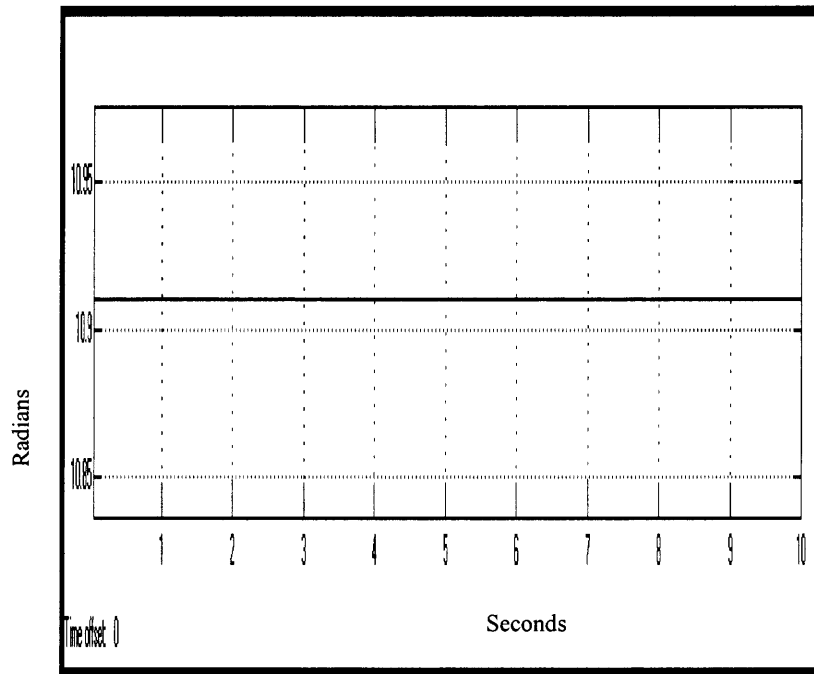

Figure 3.32. Severe Spasticity (Permanent Contraction)– Torque

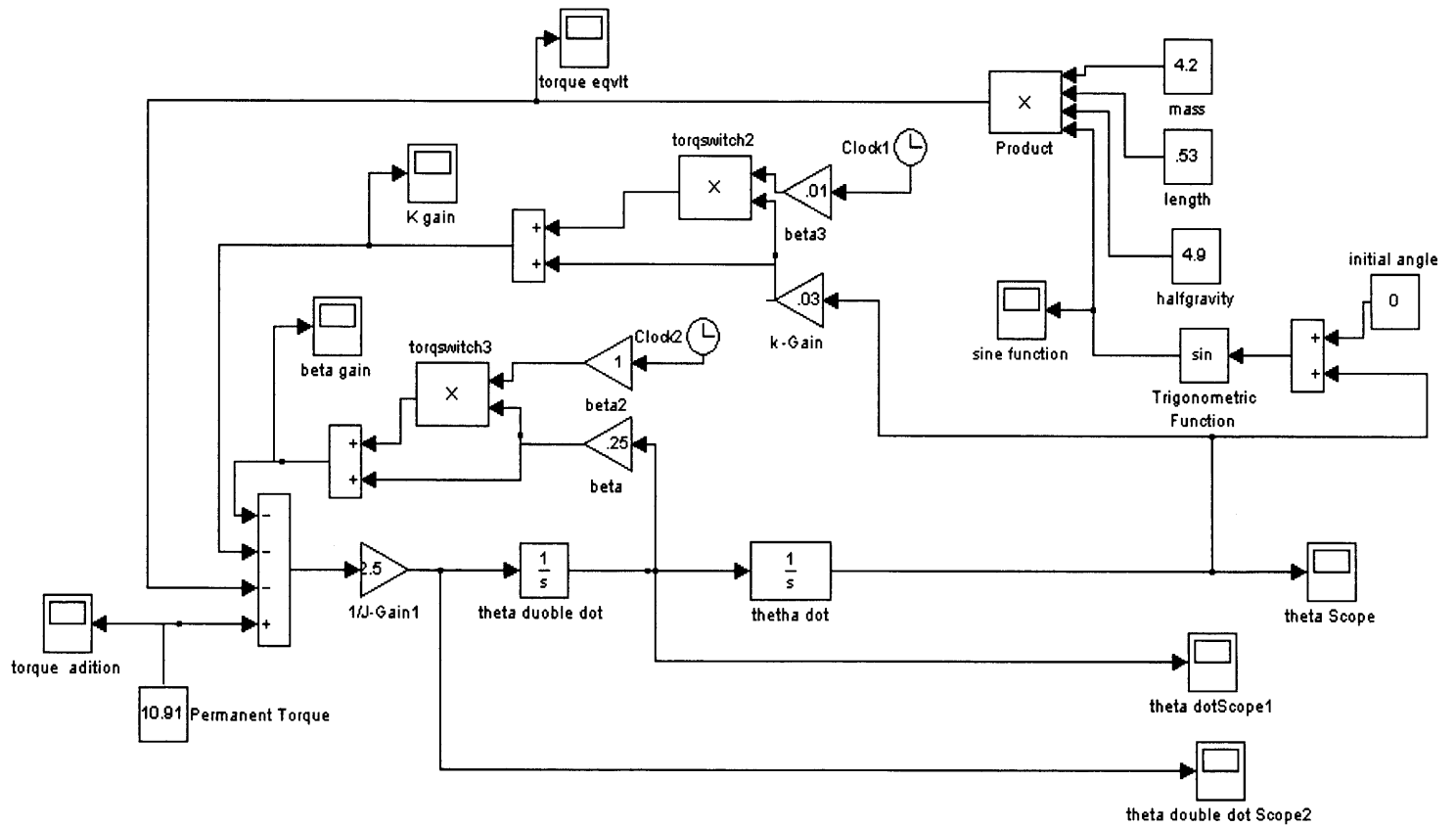

Figure 3.33. Fith Model – Severe Spasticity

In summary, in this specific model several changes have been introduced: First, it is assumed it is always contracted so no switch for On/Off position is needed. Second, one an only one permanent torque replaces the previously used combination of different torques. Third, as already explained, the damping (B) and spring (K) coefficients are increasing as a function of time.

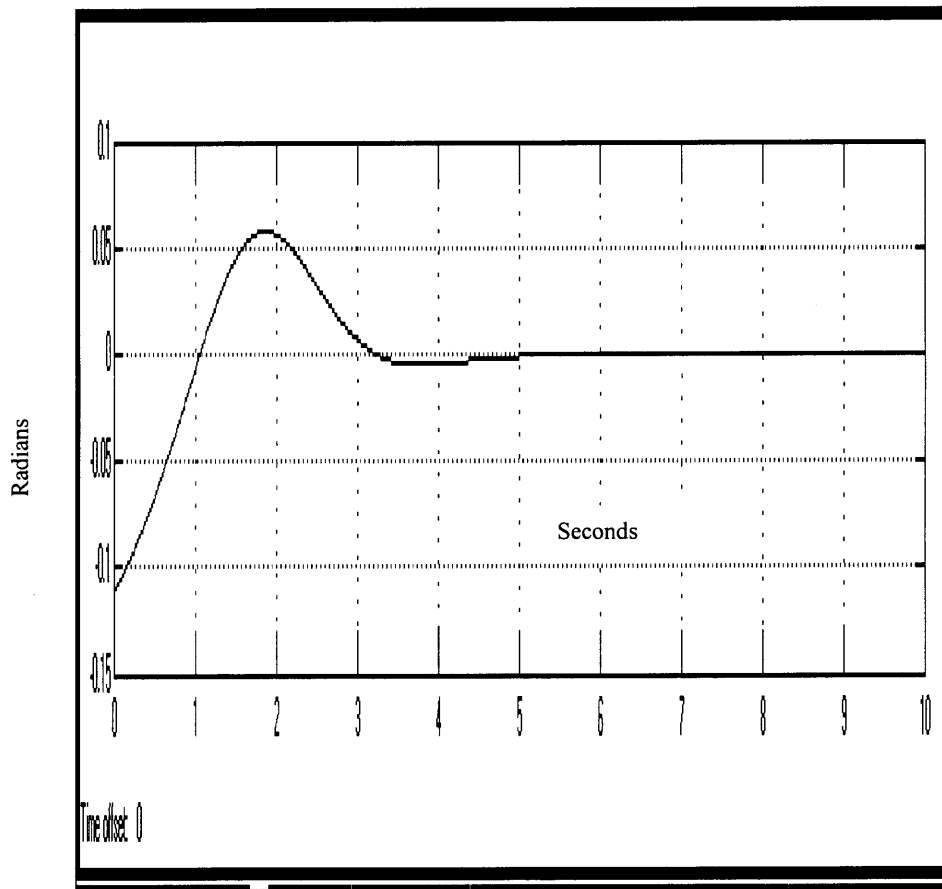

Figure 3.34. Severe Spasticity (Permanent Contraction)– Acceleration

Fifth Model -Basal Tone Contraction and Exponential Curve Regulation:

Now that the need for both final force components has been explained, they are incorporated to the model in the final step. Several particular features of this model must

be highlighted. As already discussed the torque of the muscle contraction is between 10-30 N-m. Therefore, a saturating block was incorporated to limit the basal muscle contraction.

Initially the alpha / gamma regulating function regulated only the torque activation. Now the same activating function regulates the appearance and extent of the basal muscle contractions well. Moreover, this same function regulates the power of the exponential function. Overall, it simultaneously regulates the appearance of four important parameters, and allows them to interfere with the passive movement when the Alpha/ Gamma balance is lost. In summary, these are the additional muscular torque, the exponential function that modifies the muscular torques intensity, the basal muscle contraction and the increasing value of the damping coefficient as a function of time.

Sixth Model - Model Controlled Torque Activation: The muscle activation in spasticity is significant non-linear. The spastic torque is zero except for specific instances when it is triggered for relatively short durations. In the previous model the triggering of this torque was not controlled by the model, but was specified by the experimenter. In order to understand spasticity, it is important for the model to include a controlling function, which determines the onset time and duration of spastic muscle contraction. As previously suspected by many scientists, a relation between velocity, acceleration and position is likely involved in the regulation of the triggering events of spastic muscle contractions. These contractions provide intermittent additional torque to the system. The relation between the cosine and the absolute value of the negative sine functions, of the angle Theta, regulates the torque. We will refer relationship as the "Controlling Function"(CF). The Cosine of theta is proportional to the velocity component in the

vertical or gravitational direction, and the sine of theta is proportional to the acceleration in the same direction, as well as displacement in the same direction.

Another important event is the variable permanent Basal Contraction (BC) of the muscle. In the normal subject it is modeled as nonexistent. In the spastic subject it is modeled as an increasing event, which is dependent upon the amount of uncoupling between the alpha and the gamma motoneurons. The BC increases in a nonlinear fashion in proportion to the alfa/gamma ratio and gradually replaces the intermittent muscle torque contribution in its importance in severely spastic or rigid patients.

The CF is very significant at the mild to moderate degrees of spasticity, at high levels of spasticity the more important factor is the permanent Basal Contraction (BC). In conclusion two additional essential factors are finally added to the model that are the CF (Controlling Function) and the BC (permanent Basal Contraction). They interrelate in the dynamics of the system in such a way that one of them diminishes as the importance of the other one grows.

This model was initially labeled as “-Cosine - Sine Controlled Torque Activation”. It is more appropriate to refer to it simply as the “Final Model” or “Pendulum Knee Drop Test Model” (PKDT) or even will be referred as to the “model”.

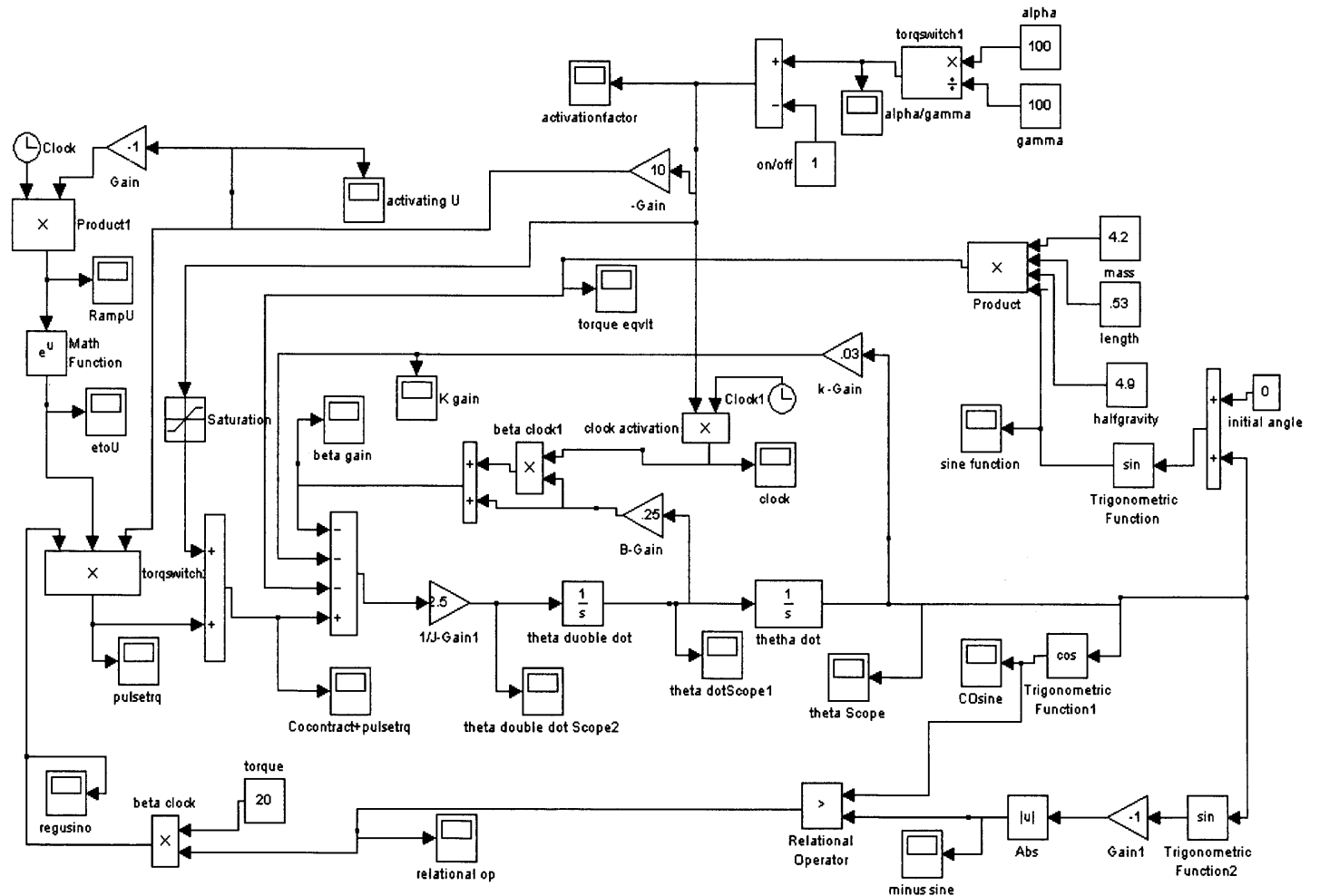

Figure 3.35. Sixth Model – Final Model- Pendulum Knee Drop Test

The whole spectrum of results will be analyzed in then following chapter when the results are analyzed. Some examples illustrate how this new model sufficiently represents simulation of normal, mild and severe spasticity.

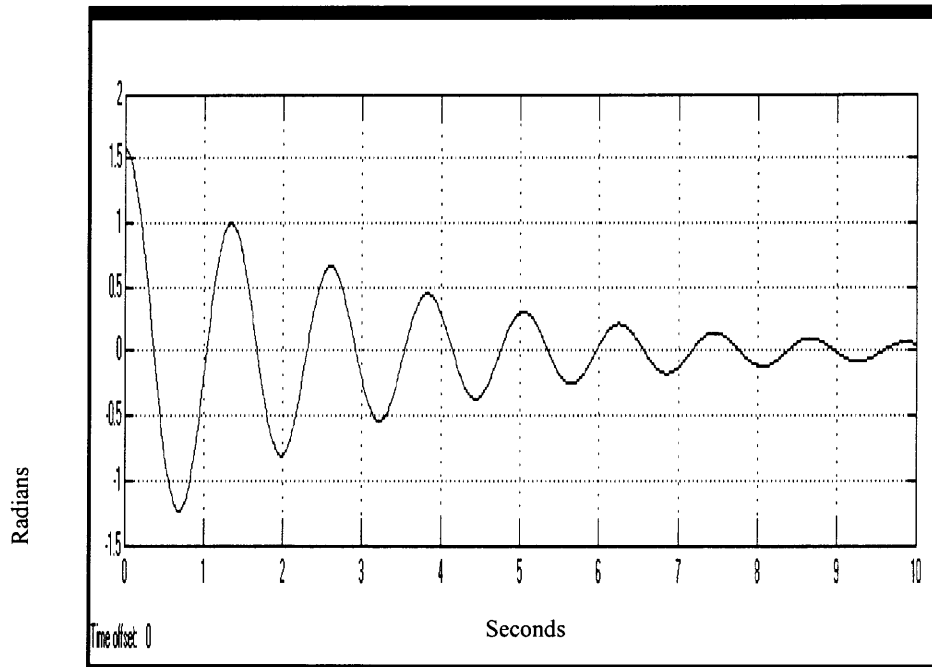

Figure 3.36. Final Model –Knee Drop Pendulum Test – Position- (No Spasticity)

The first graph shows a simulated normal subject. This graph includes no altered response on the expected second order underdamped differential equation. The following graph (fig. 3.37) shows a simulation of mild spasticity. Notice how the final cycles disappear much faster than earlier models.

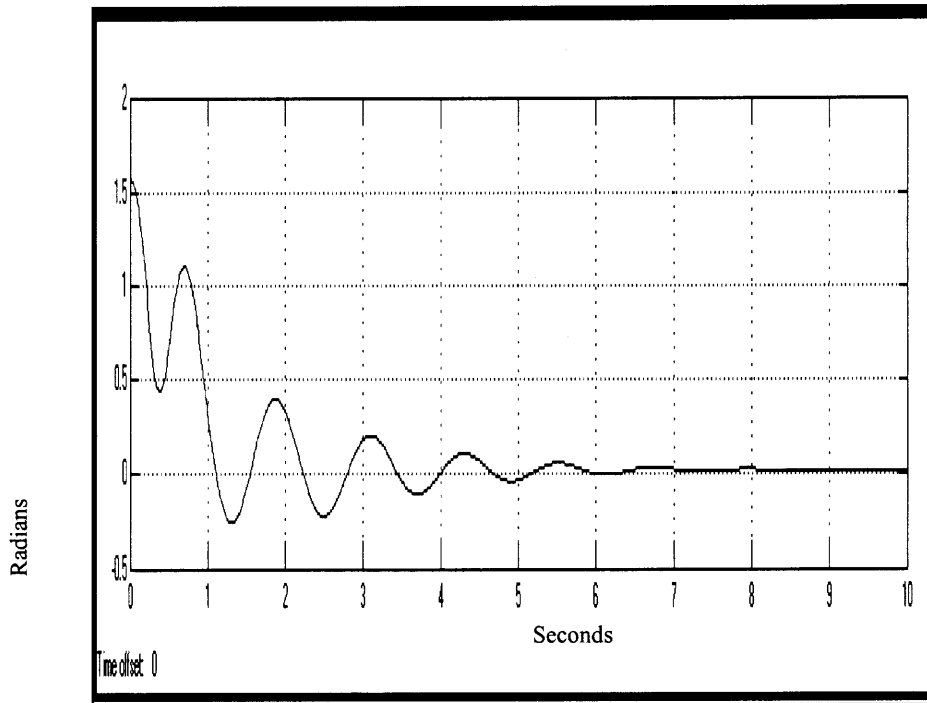

Figure 3.37. Final Model –Knee Drop Pendulum Test – Position- (Mild Spasticity)

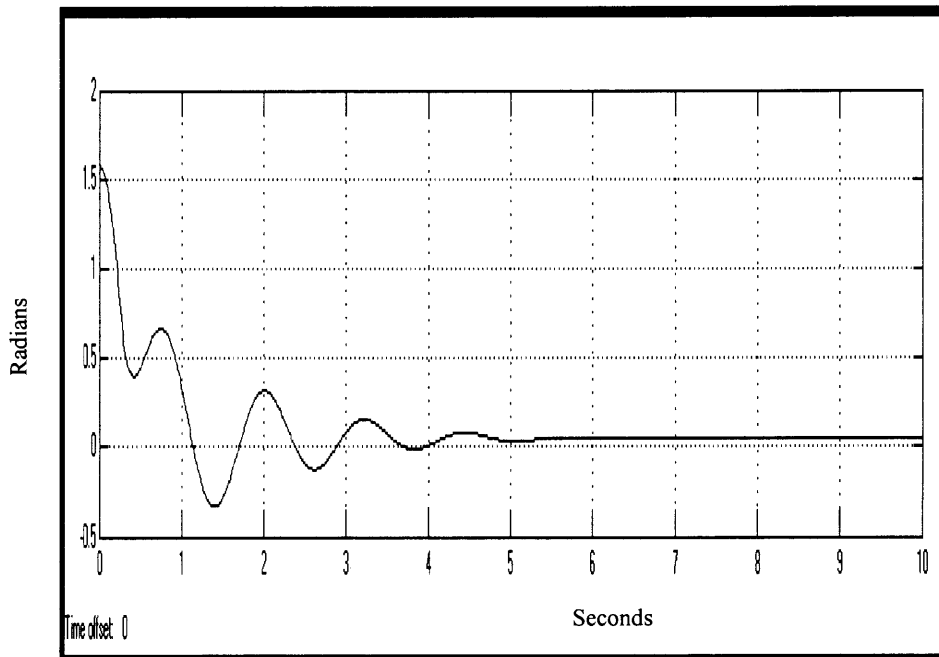

Figure 3.38. Final Model –Knee Drop Pendulum Test – Position- (Moderate Spasticity)

Moderate Spasticity (fig. 3.38) is depicted by the first two cycle occurring before the limb reaches the gravitational equilibrium and increases the accelerated damping in the last cycles.

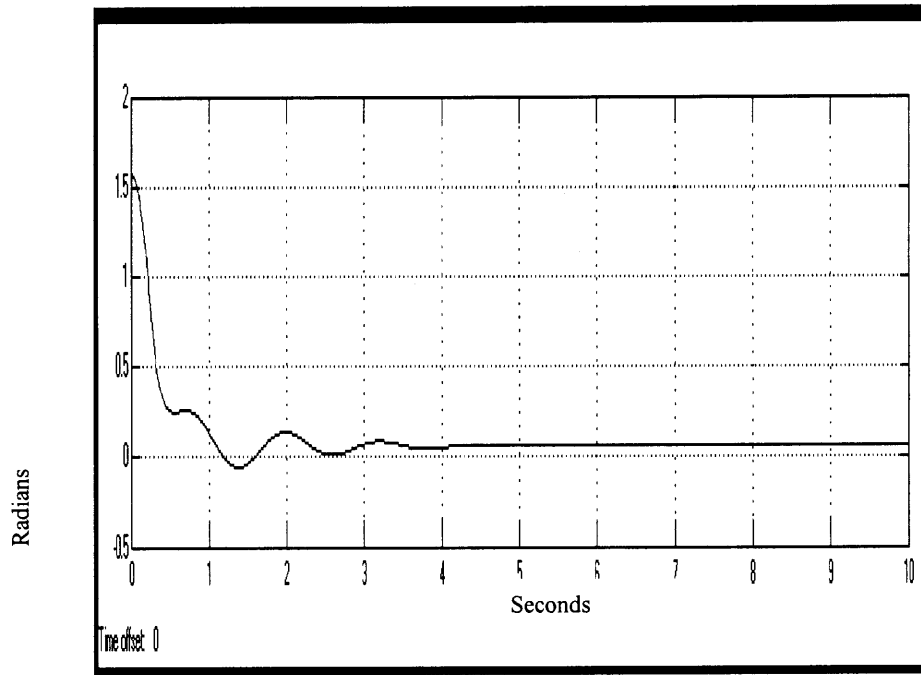

Figure 3.39. Final Model –Knee Drop Pendulum Test – Position- (Severe Spasticity)

In this figure (fig. 3.39) a great altered response is seen as reflected by the smoothing of the first two cycles and a very accelerated damping process through the rest of the trajectory. A mild elevation of the equilibrium point can be seen. In the last figure of this section (fig.3.40) a very severely spastic patient is illustrated. Notice the absence of an oscillatory pattern, changing from an underdamped pattern to a critically damped pattern.

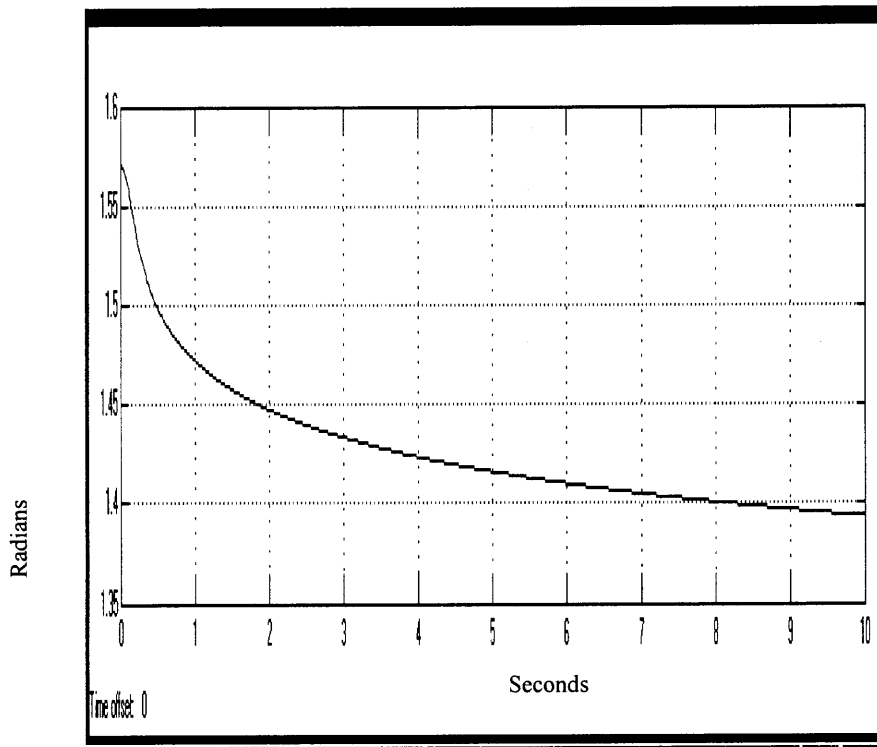

Figure 3.40. Final Model –Knee Drop Pendulum Test–Position- (Very severe Spasticity)

Also notice, the elevation of the final equilibrium point above gravitational vertical as an indication of limited motion of the limb during the exam.

CHAPTER 4

RESULTS

The final model described in the previous section allows us to conduct simulations of various types of subjects. Varying only the relationship between gamma and alpha motoneurons, we are able to produce simulations ranging from no spasticity to very severe spasticity.

This variation is made exclusively in the gamma motoneurons value in a decremented fashion, at intervals of 10, starting at a 100 (100%) and ending at 1 (1%). For each simulation the recorded position, velocity, acceleration and spastic torque input are analyzed. The behavior of each regulating function and reason why it was included in is also discussed.

First Simulation- normal subject-: This is expected to behave as an underdamped oscillator system, with a pseudo-periodic pattern.

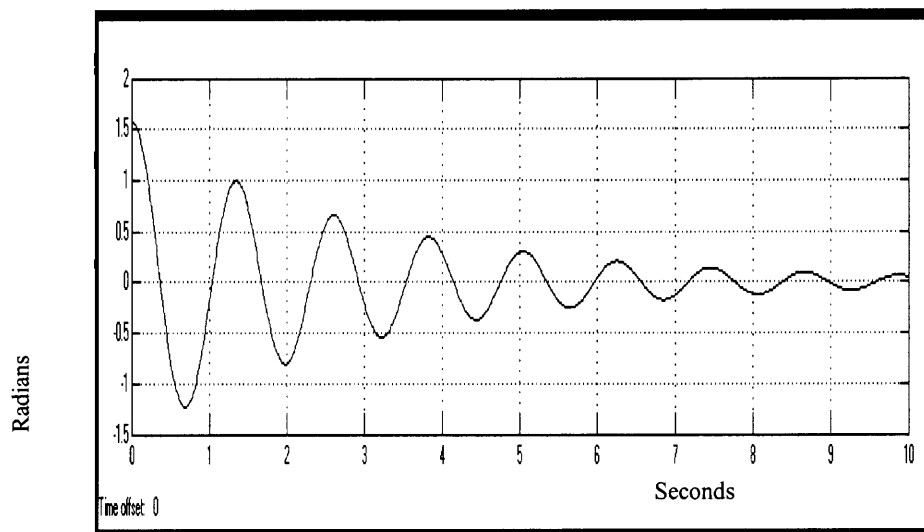

Figure 4.1. Normal Subject- Position

As expected, the trajectory fulfils the criteria found in the literature describing a normal position, velocity and acceleration pattern of behavior in a Pendulum Knee Drop Test. No additional torque comes from the muscles.

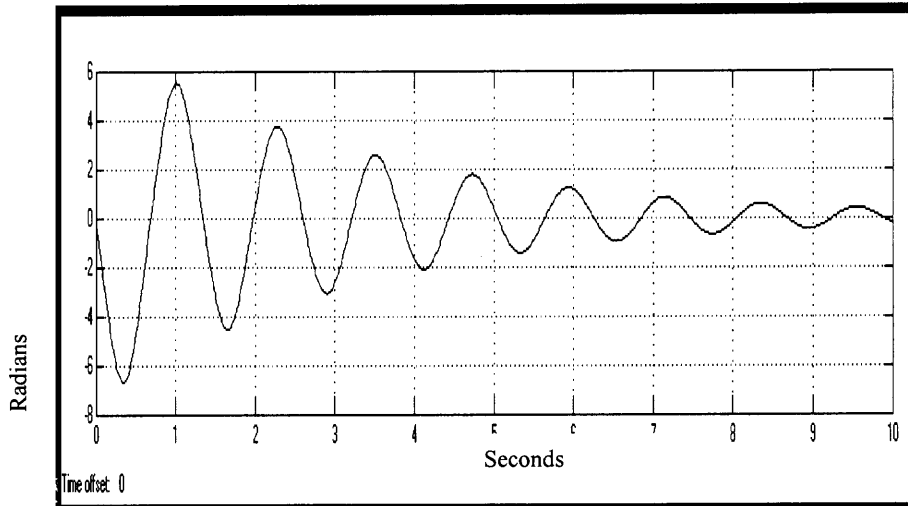

Figure 4.2. Normal Subject- Position

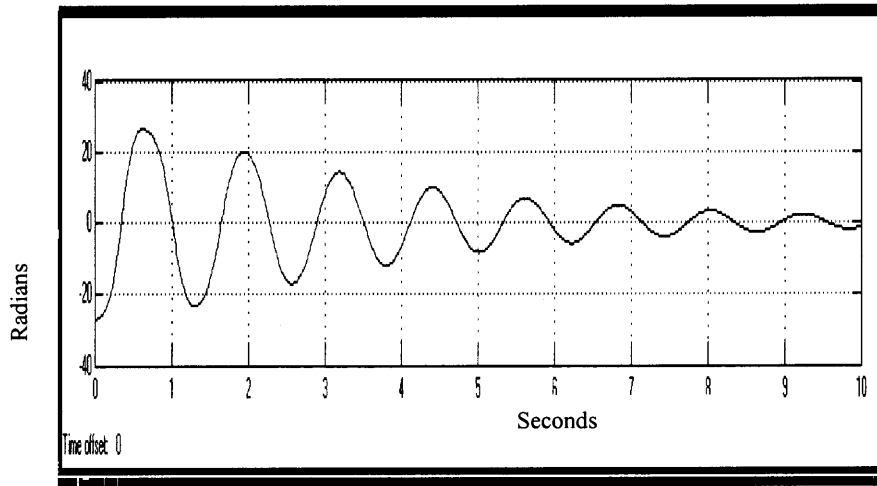

Figure 4.3. Normal Subject- Acceleration

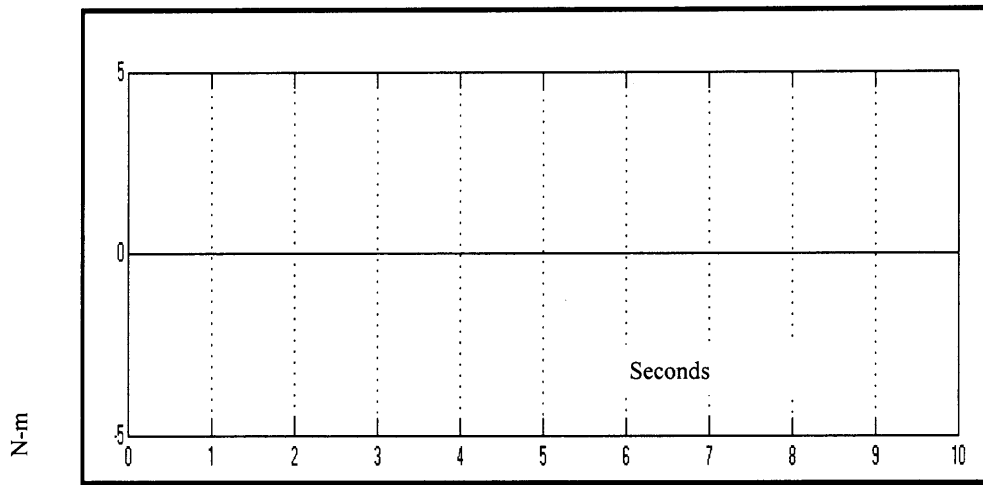

Figure 4.4. Normal Subject- Muscle Torque

Second Simulation- Gamma 90 % -:

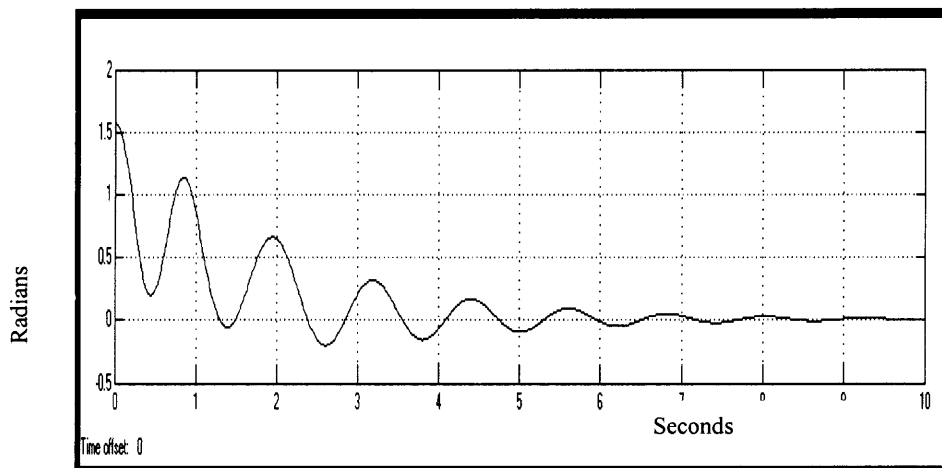

Figure 4.5. Gamma 90 % - Position

As a result of the input from the muscle torque a distortion is starting to appear in the trajectory. Notice the influence on the first two cycles, characterized deviations from the expected pendular motion. Also notice the exaggerated damping of the last cycles.

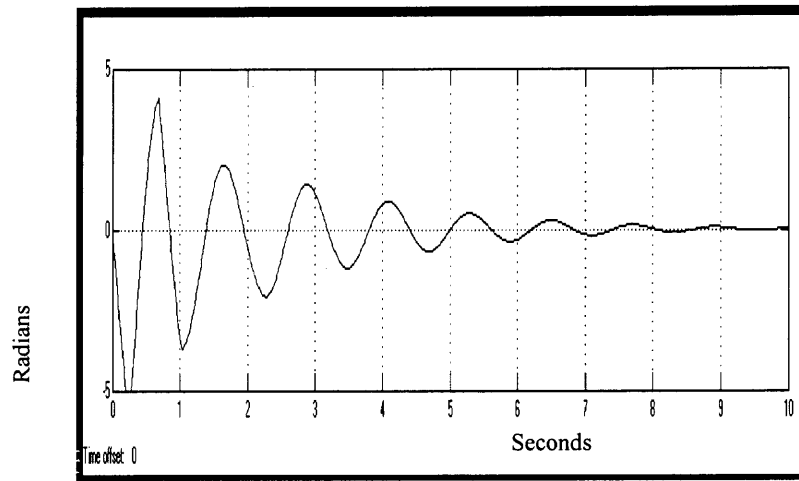

Figure 4.6. Gamma 90 % - Velocity

Under the influence of the muscular torque, the trajectory of the initial one and a half cycles has an altered appearance. In the acceleration graph it is easy to observe the torque influence (fig. 4.7) on the system. The amount of basal muscle tone starts to increase with a scarcely noticeable, a value of 0.1 units (fig. 4.9)

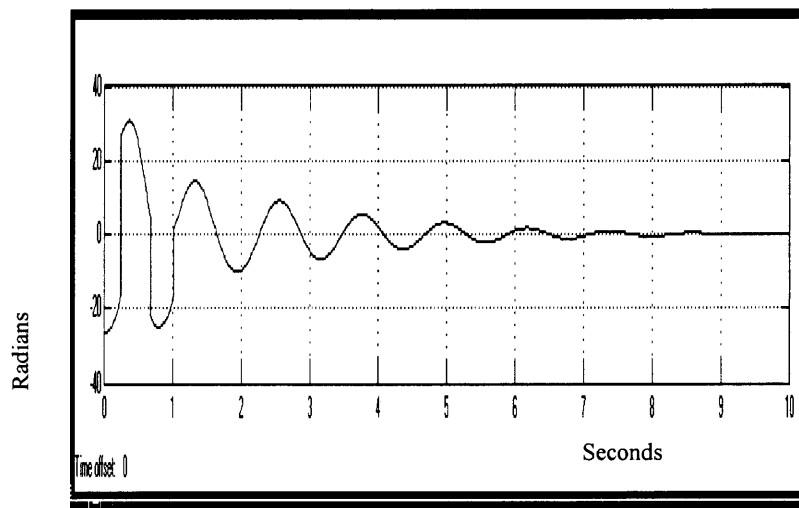

Figure 4.7. Gamma 90 % - Acceleration

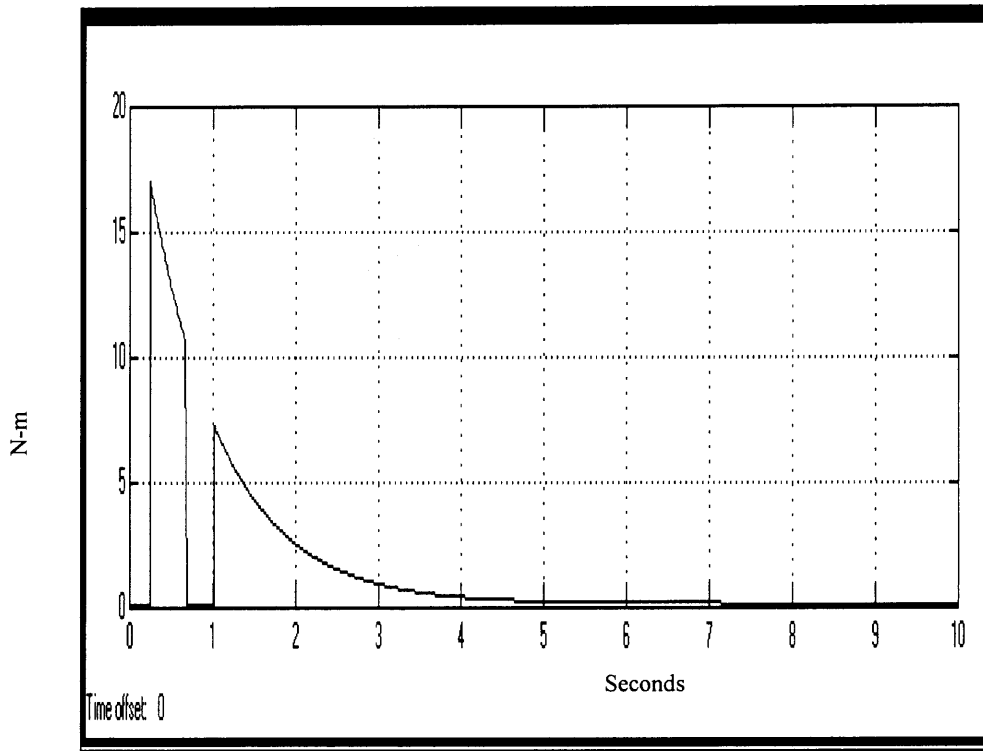

Figure 4.8. Gamma 90 % Muscle Torque

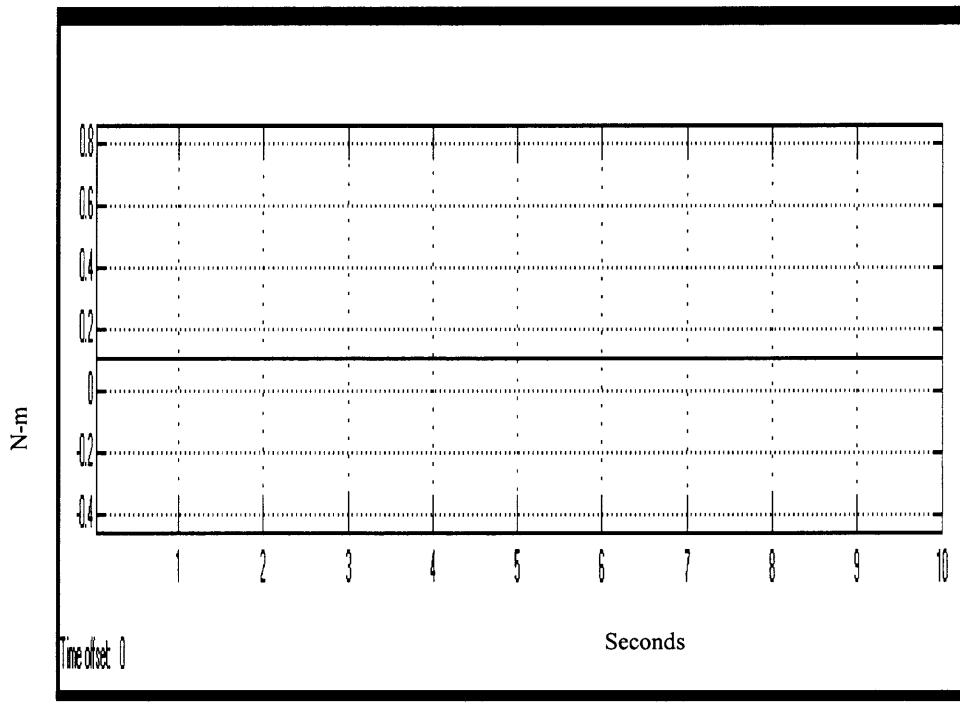
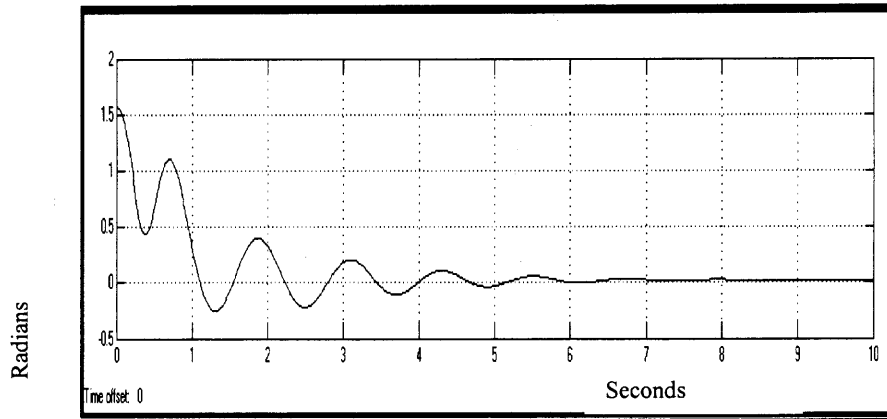
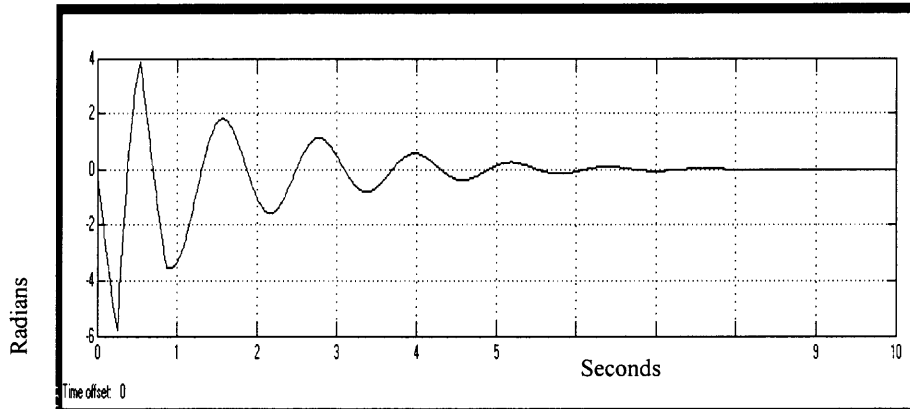
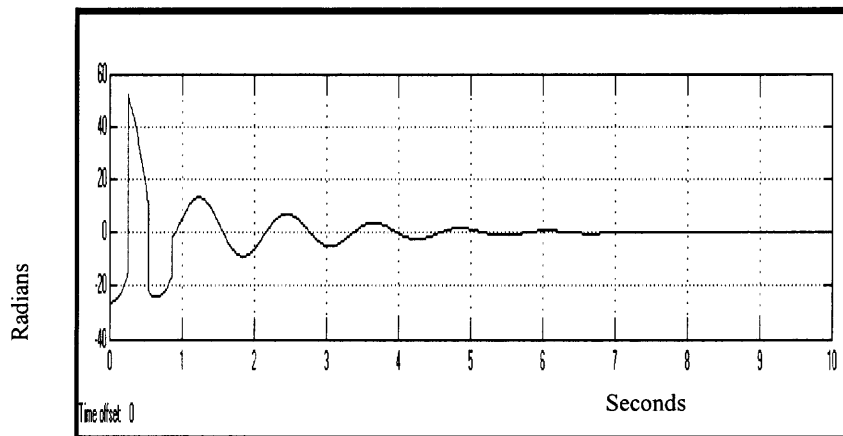

Figure 4.9. Gamma 90 % Basal tone

Third Simulation-Gamma 80:

**Figure 4.10. Gamma 80 % Position****Figure 4.11. Gamma 80 % Velocity****Figure 4.12. Gamma 80 % Acceleration**

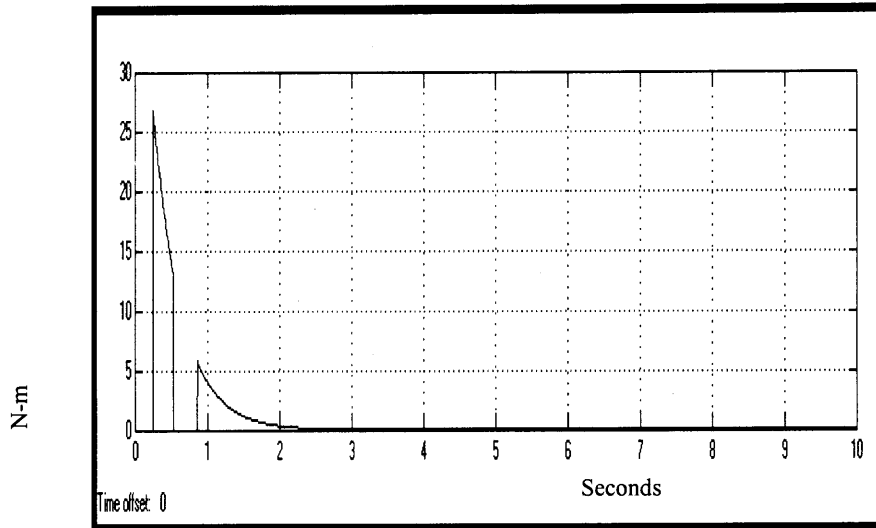

Figure 4.13. Gamma 80 % Muscle torque

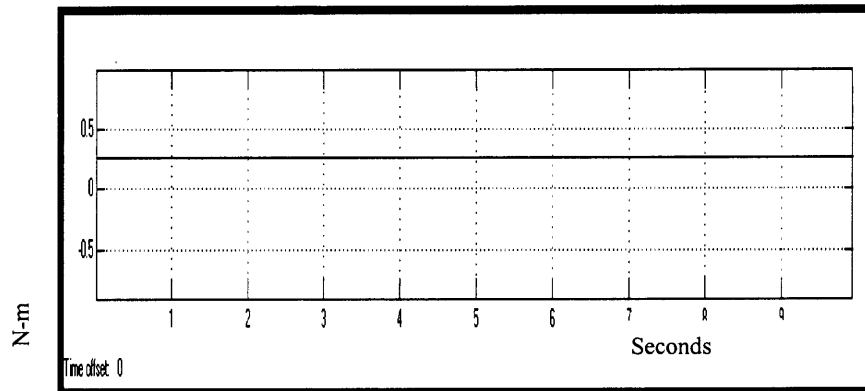

Figure 4.14. Basal tone

The progressive intermittent muscle torque influence, in the initial segment of the exam, is now very notorious, even though, the absolute amount of the torque exerted by the isolated muscle contraction is diminishing. The basal muscular tone continues to increase in an exponential form reaching a value of approximately 0.3 units at this stage. The basal muscular tone does not appear to influence much the results at this stage.

Fourth Simulation Gamma 70%

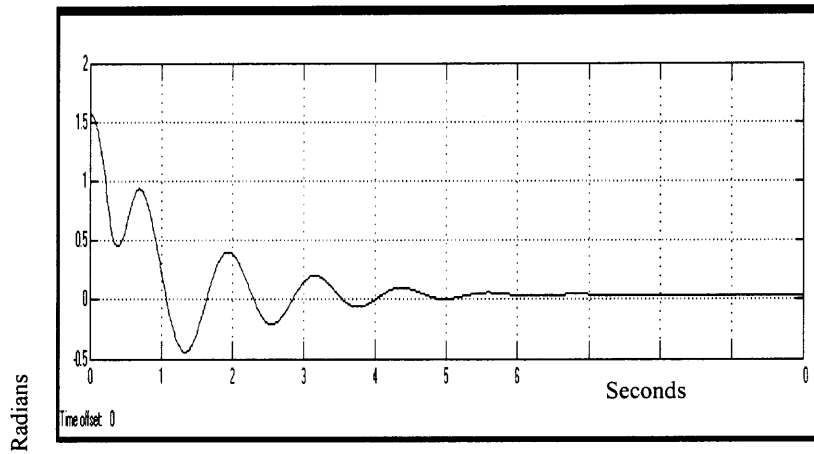

Figure 4.15. Fourth Simulation Gamma 70%-Position

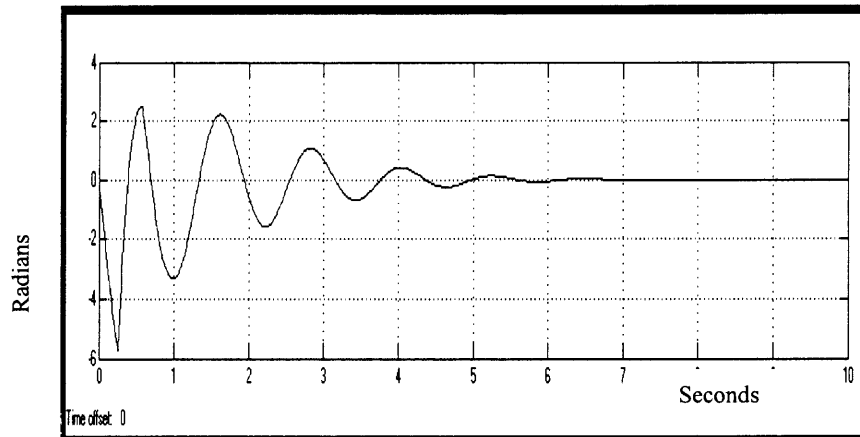

Figure 4.16. Fourth Simulation Gamma 70%-Velocity

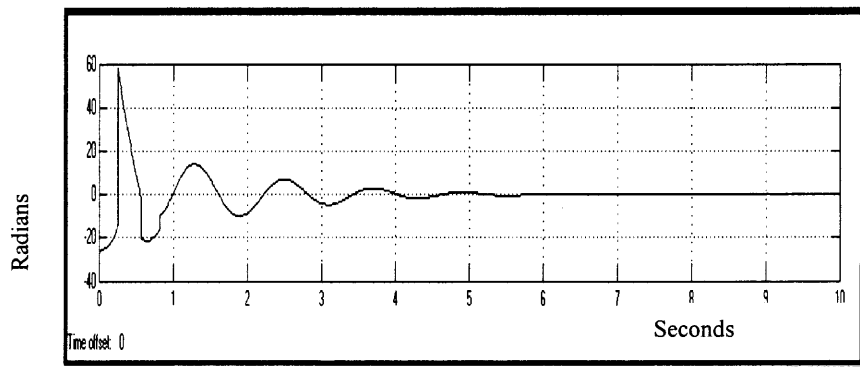

Figure 4.17. Fourth Simulation Gamma 70%-Acceleration

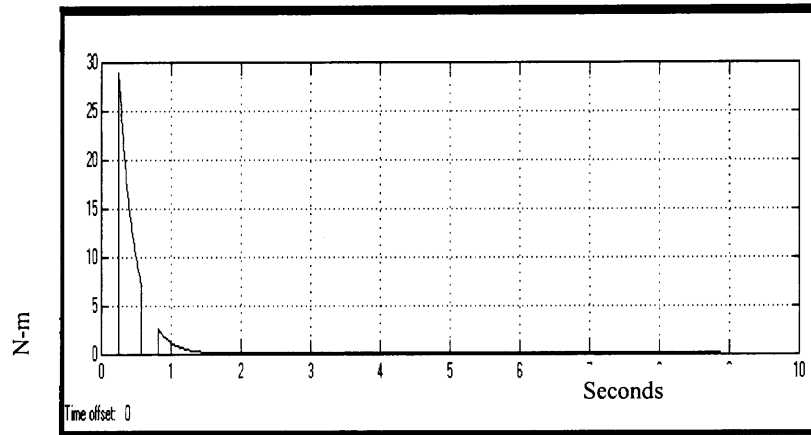

Figure 4.18. Fourth Simulation Gamma 70%-Torque

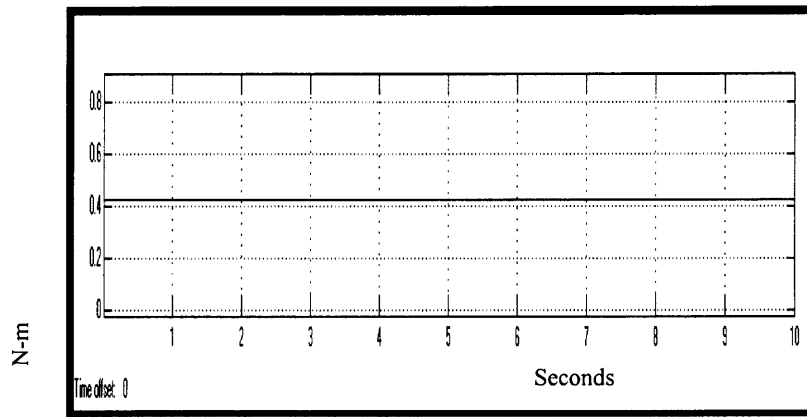

Figure 4.19. Fourth Simulation Gamma 70%-Basal

The whole influence is still governed by the muscle torque, but each time, it is more evident that the behavior of the system trends to loose its dependency from these isolated torque influence, and tries to find a new equilibrium point dependant from the basal muscle contraction.

Fifth Simulation Gamma 60 %

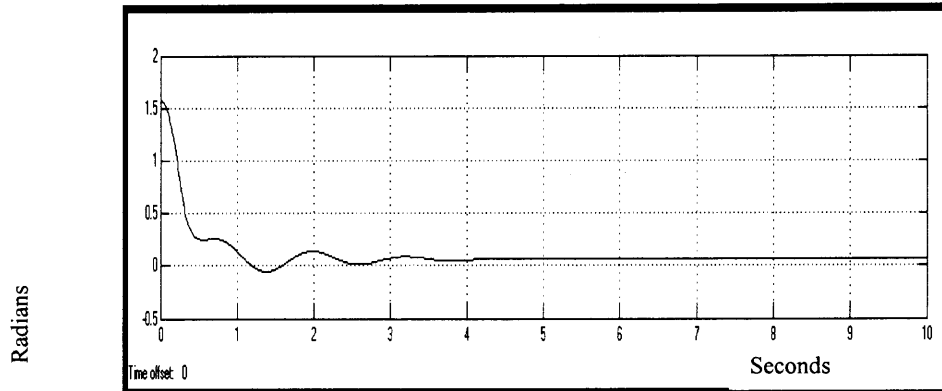

Figure 4.20. Fifth Simulation Gamma 60 % Position

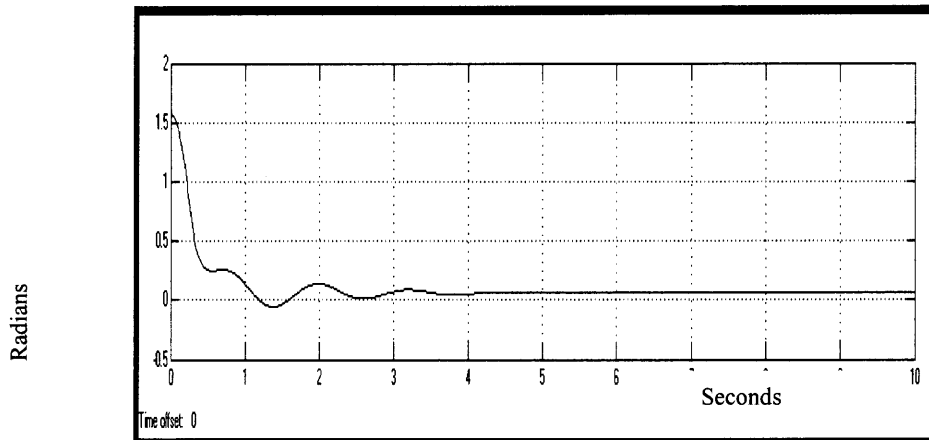

Figure 4.21. Fifth Simulation Gamma 60% Velocity

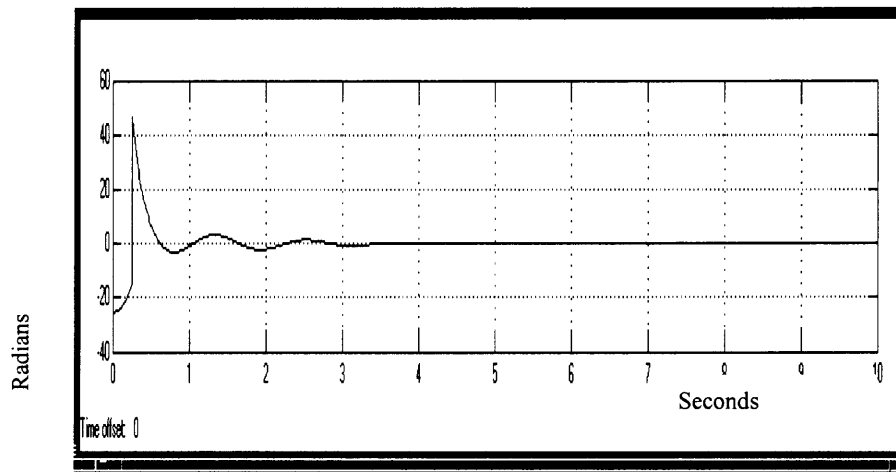

Figure 4.22. Fifth Simulation Gamma 60% Acceleration

As it is evident on the acceleration graph, that there is still considerable input from the muscular contraction. Never the less there is just one single spike remaining in the initial part of the event. The basal muscular tone value is now above a half unit.

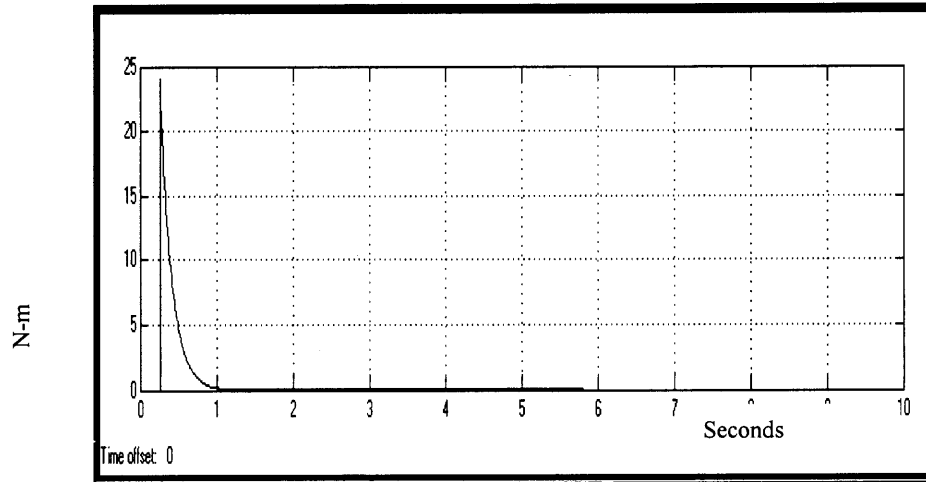

Figure 4.23. Fifth Simulation Gamma 60% Torque

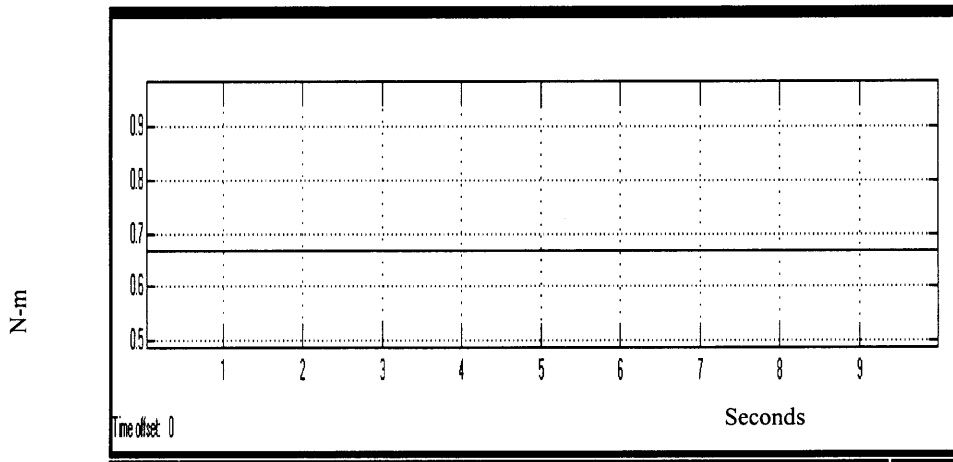

Figure 4.24. Fifth Simulation Gamma 60% Basal Tone

Sixth Simulation Gamma 50 %

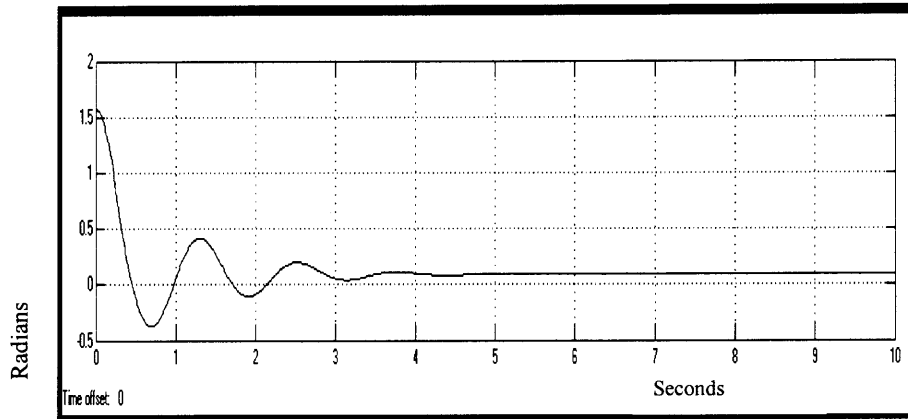

Figure 4.25. Sixth Simulation Gamma 50 %Position

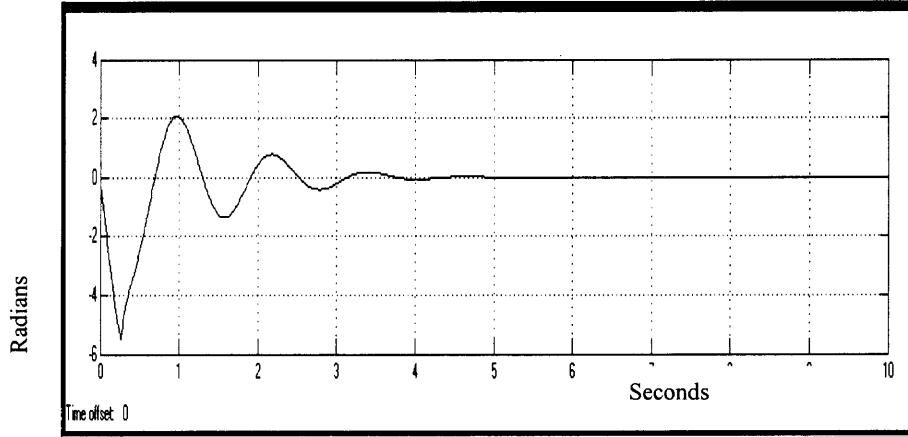

Figure 4.26. Sixth Simulation Velocity

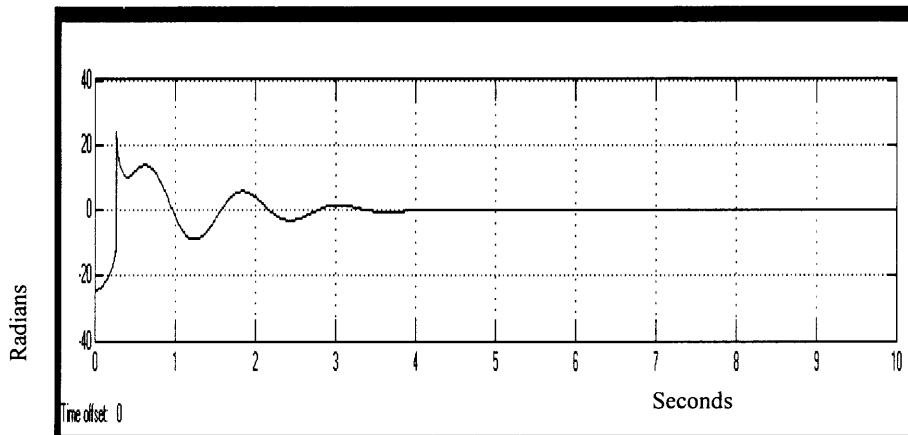

Figure 4.27. Sixth Simulation Acceleration

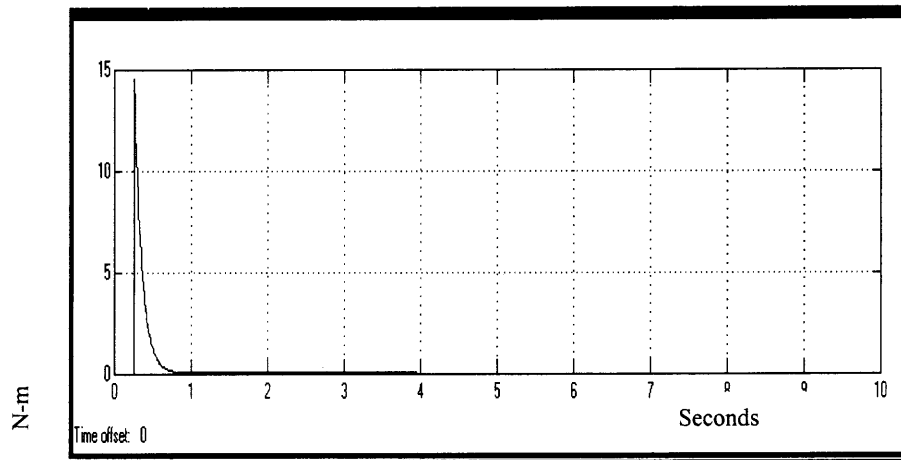

Figure 4.28. Sixth Simulation Gamma 50% Torque

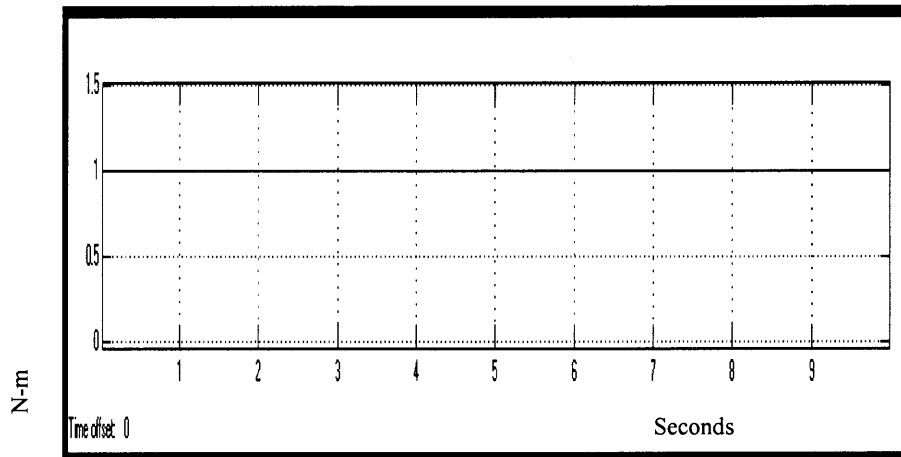

Figure 4.29. Sixth Simulation Gamma 50% Torque Basal Tone

The interaction between the muscle contraction and the basal tone shapes the appearance of the trajectory. The basal tone has acquired the value of 1 unit and begins to dominate the trajectory. The muscle contraction provides less influence as the basal tone increases.

Seventh Simulation Gamma 40%

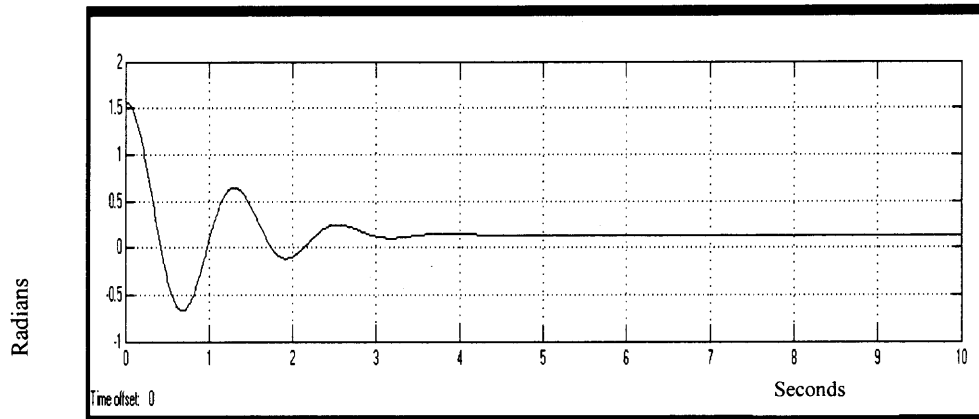

Figure 4.30. Seventh Simulation Gamma 40% position

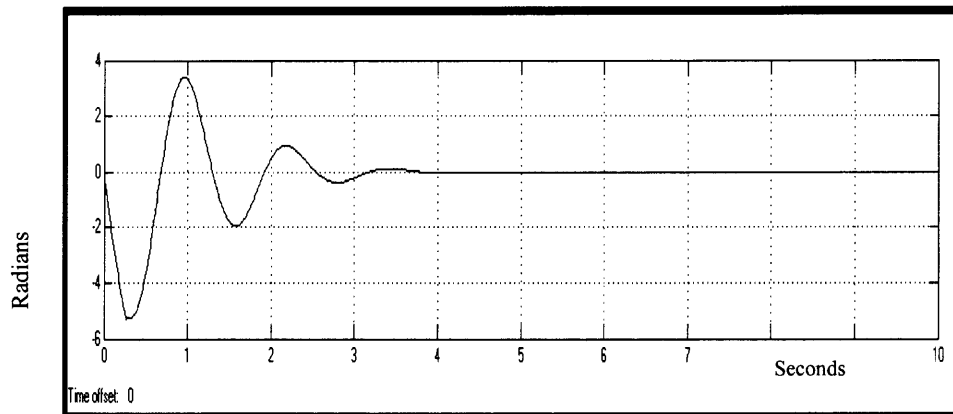

Figure 4.31. Seventh Simulation Gamma 40% Velocity

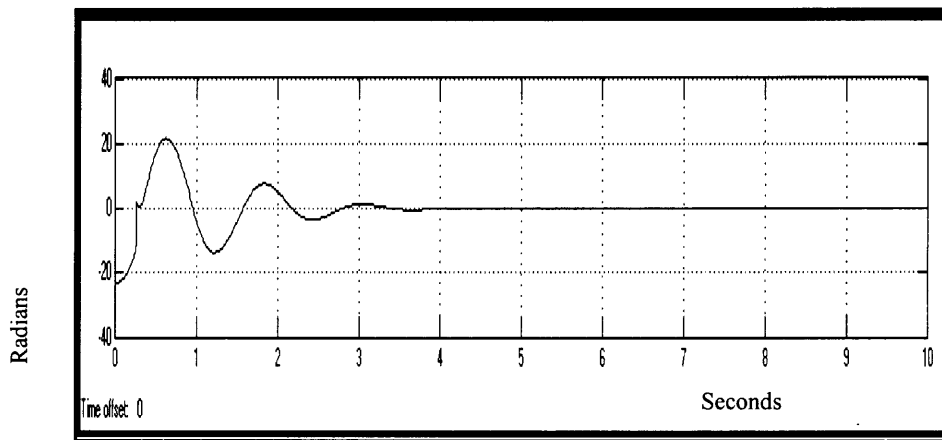

Figure 4.32. Seventh Simulation Gamma 40% Acceleration

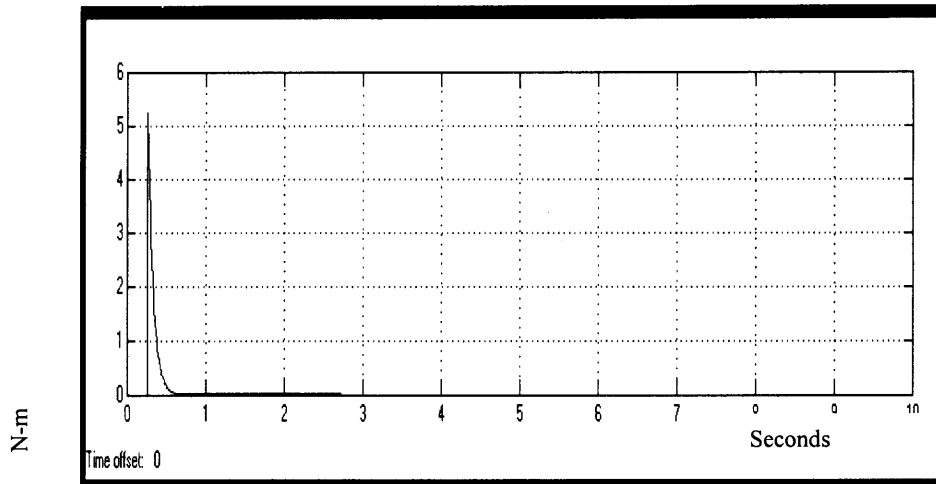

Figure 4.33. Seventh Simulation Gamma 40% Torque

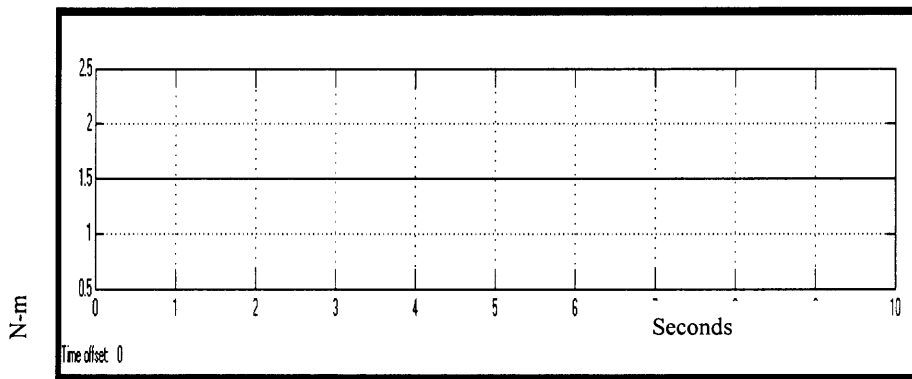

Figure 4.34. Seventh Simulation Gamma 40% Basal Tone

The value of the basal tone is going to increment in a very rapid way. As you can see, it is now fifty percent greater than in the previous stage. The value of the torque starts to disappear.

Eighth Simulation Gamma 30 %

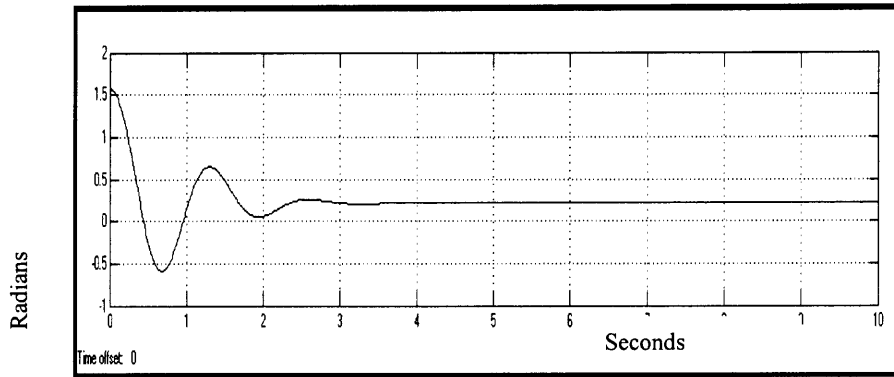

Figure 4.35. Eighth Simulation Gamma 30 % Position

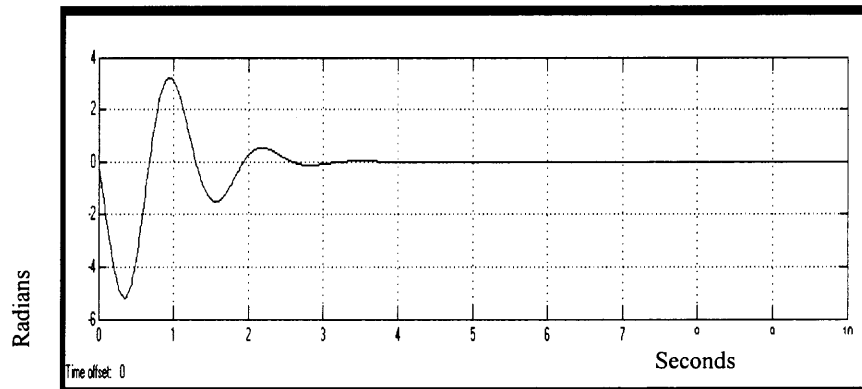

Figure 4.36. Eighth Simulation Gamma 30 % Velocity

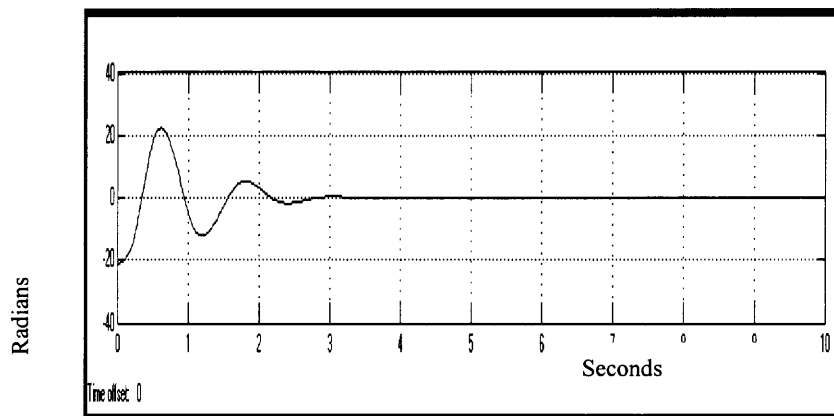

Figure 4.37. Eighth Simulation Gamma 30 % Acceleration

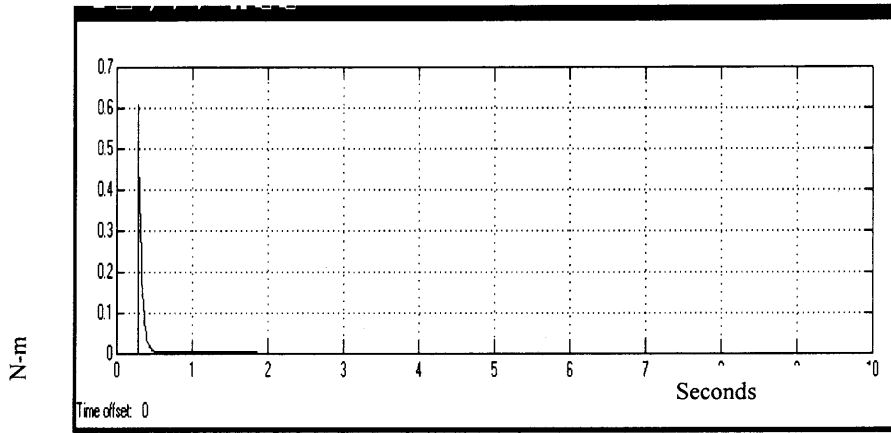

Figure 4.38. Eighth Simulation Gamma 30 % Torque

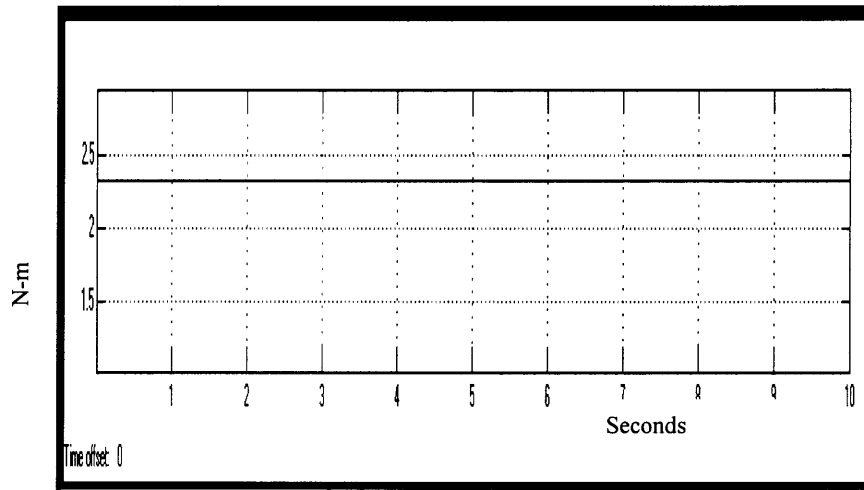

Figure 4.39. Eighth Simulation Gamma 30 % Basal Tone

The amplitude of the muscle torque is less than 1 N-m. The dominating influence has become the interaction between the basal tone and the gravitational force.

Ninth Simulation Gamma 20 %

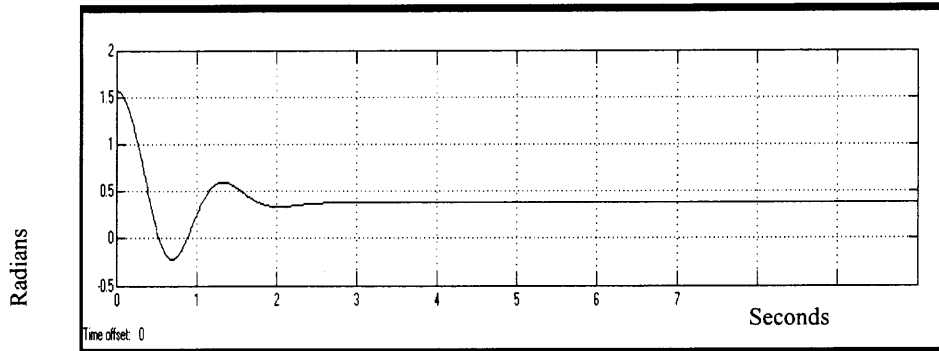

Figure 4.40. Ninth Simulation Gamma 20 % Position

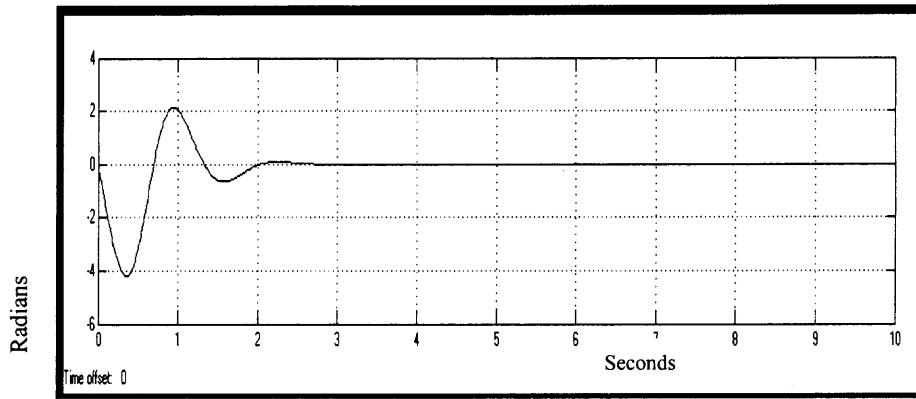

Figure 4.41. Ninth Simulation Gamma 20 % Velocity

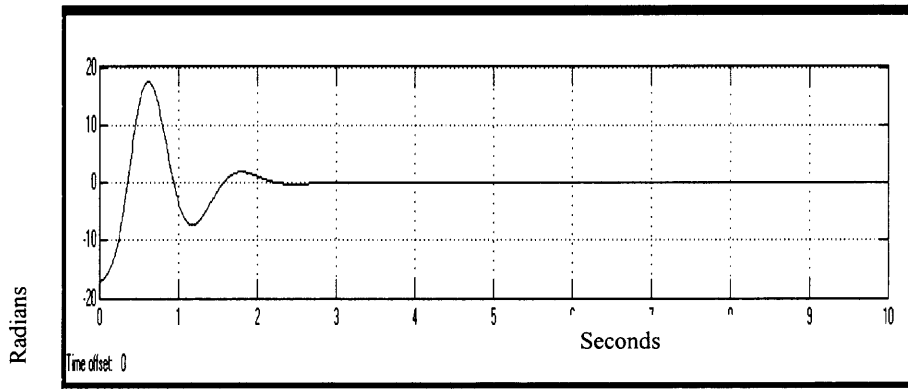

Figure 4.42. Ninth Simulation Gamma 20 % Acceleration

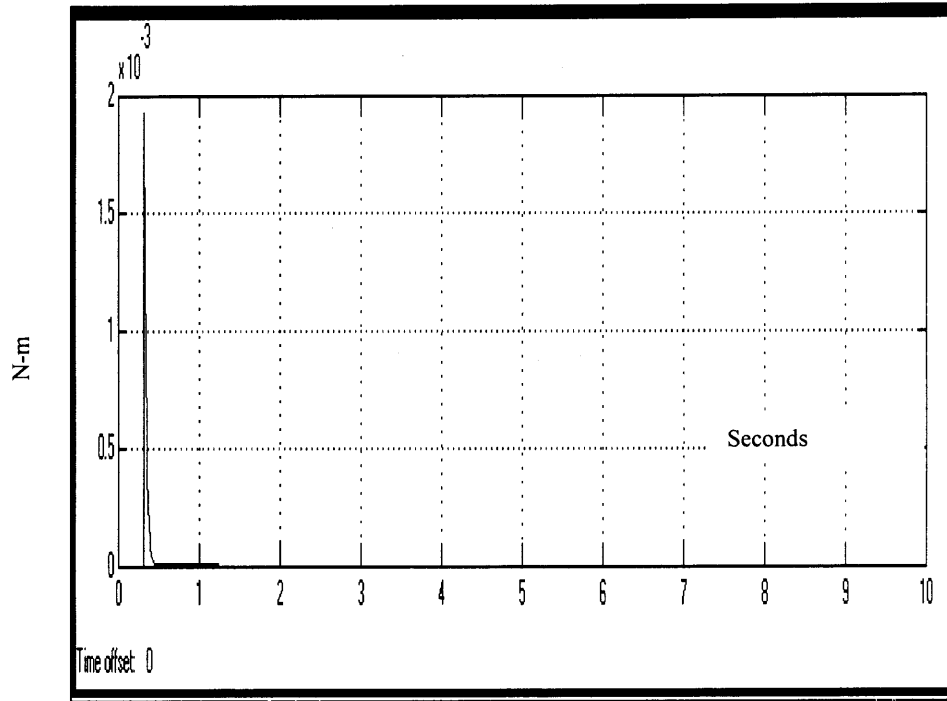

Figure 4.43. Ninth Simulation Gamma 20 % Torque

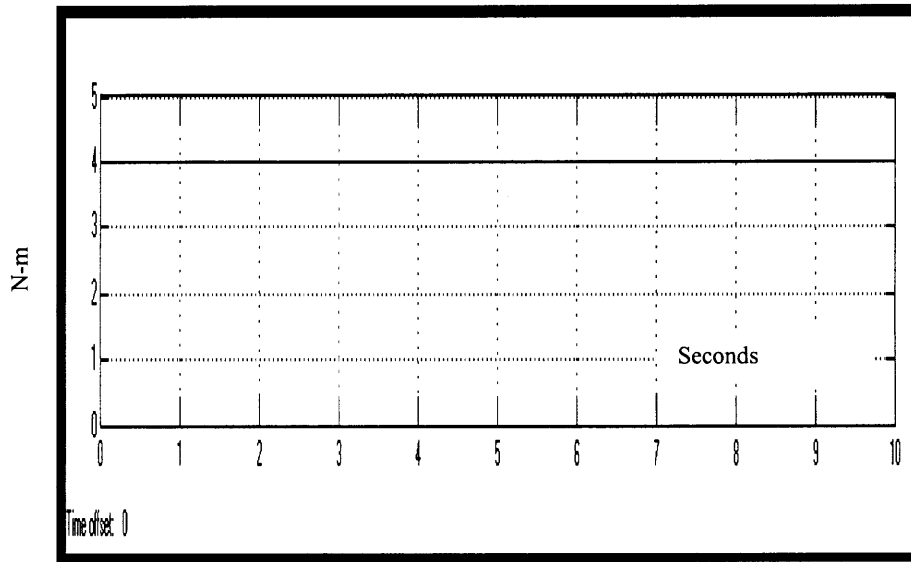

Figure 4.44. Ninth Simulation Gamma 20 % Basal Tone

Ninth Simulation Gamma 10 %

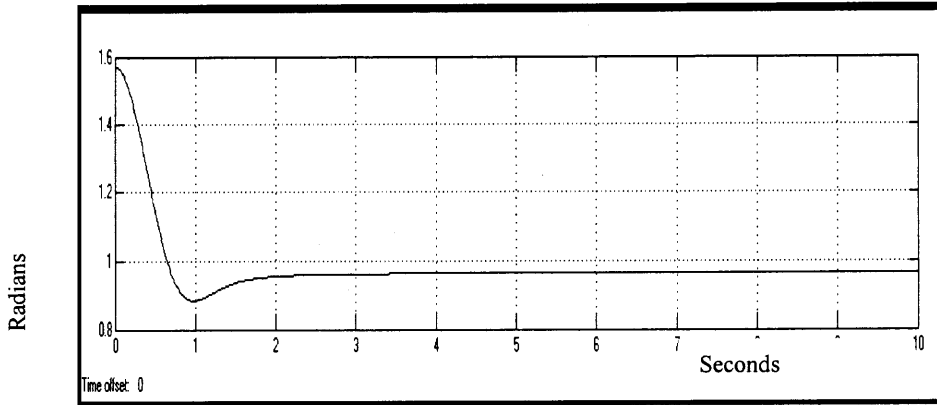

Figure 4.45. Ninth Simulation Gamma 10 % Position

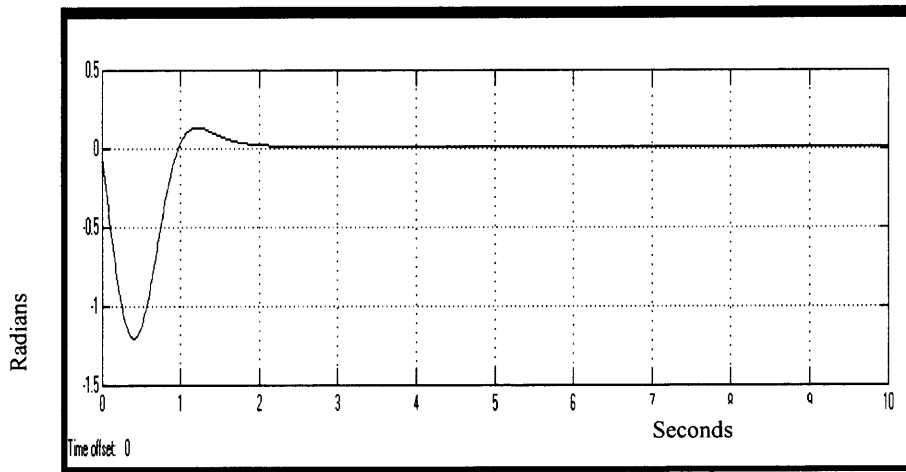

Figure 4.46. Ninth Simulation Gamma 10 % Velocity

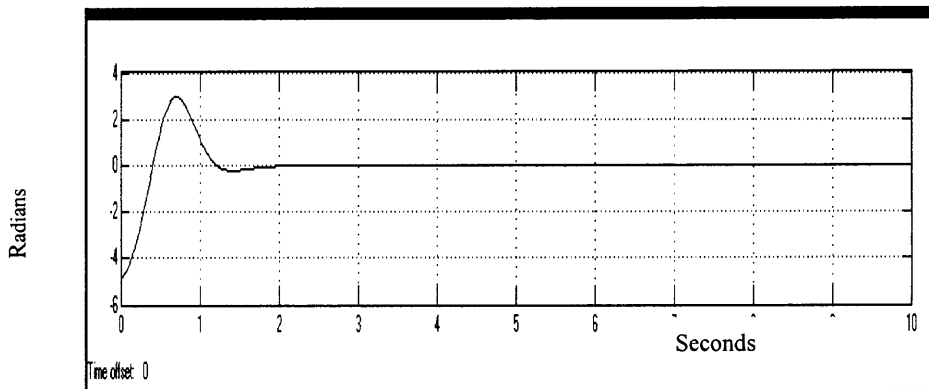

Figure 4.47. Ninth Simulation Gamma 10 % Acceleration

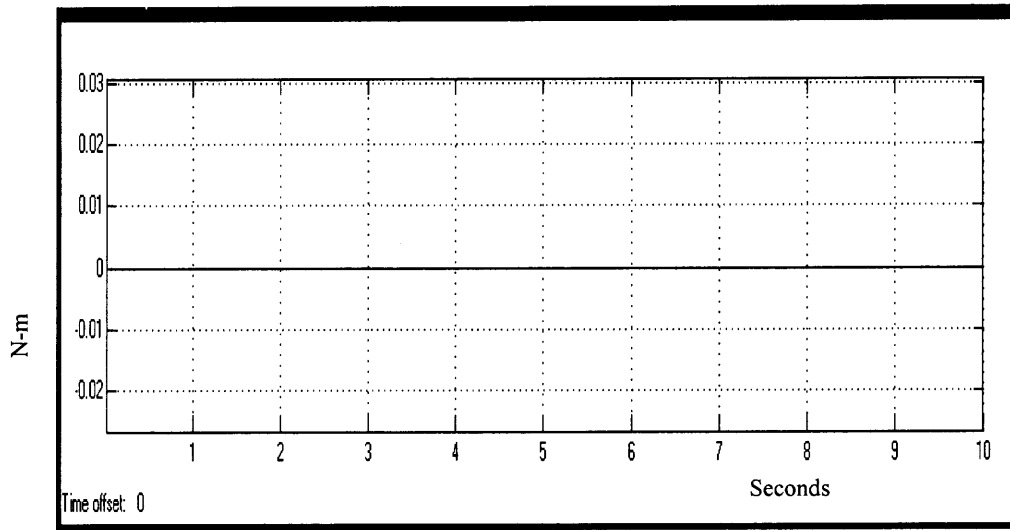

Figure 4.48. Ninth Simulation Gamma 10 % Torque

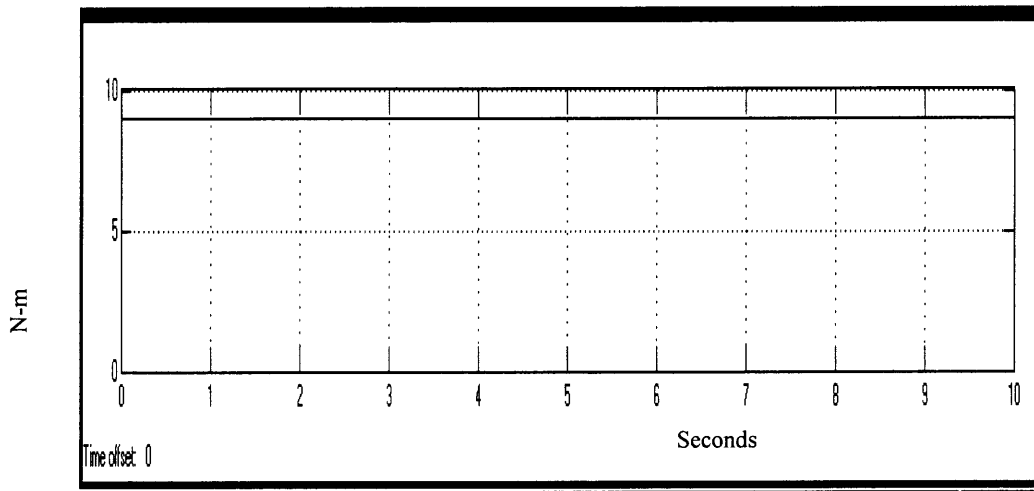

Figure 4.49 Ninth Simulation Gamma 10 % Basal Tone

The influence from the isolated muscular contraction has finally disappeared. The basal tone contraction shifts the final resting point of equilibrium as explained in a previous chapter.

Tenth Simulation Gamma 1 %

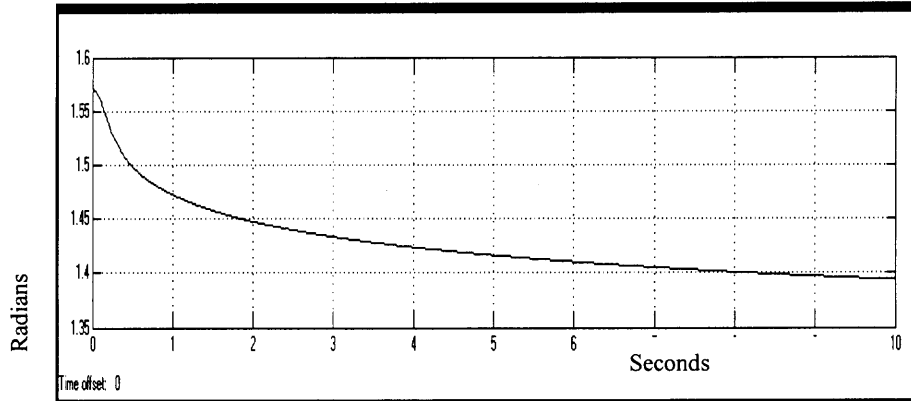

Figure 4.50. Tenth Simulation Gamma 1 % Position

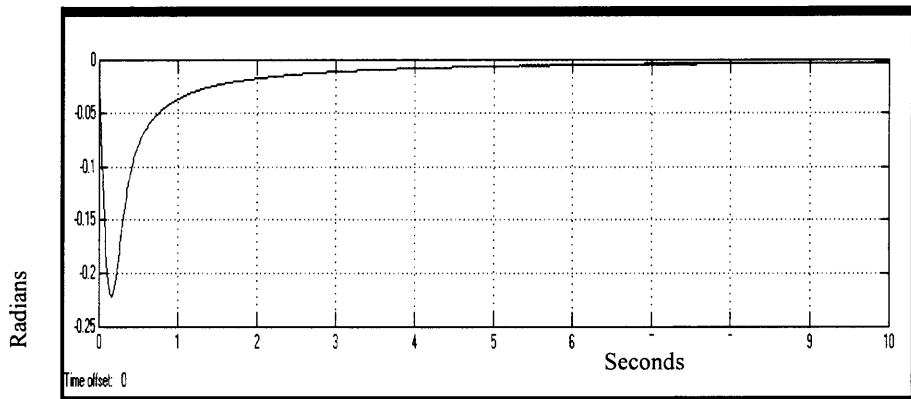

Figure 4.51. Tenth Simulation Gamma 1 % Velocity

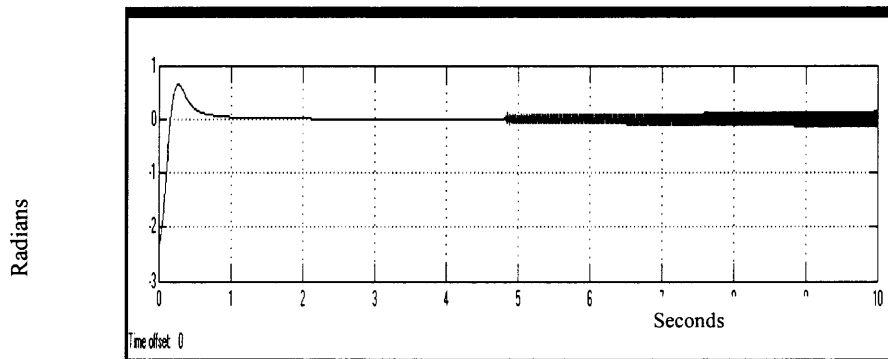

Figure 4.52. Tenth Simulation Gamma 1 % Acceleration

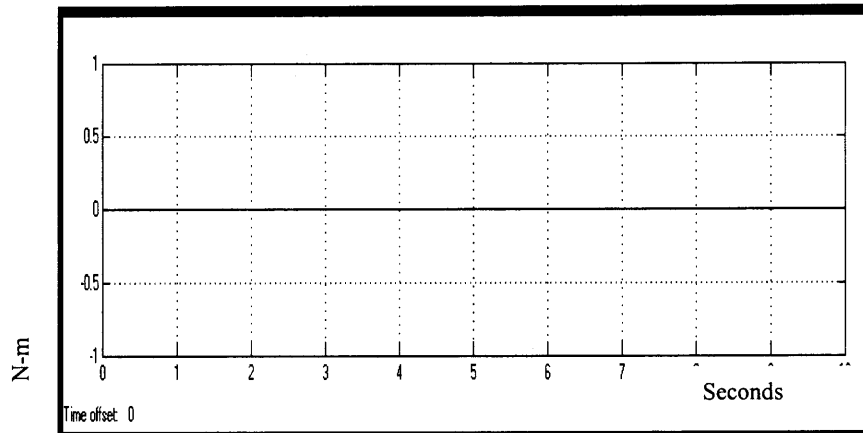

Figure 4.53.Tenth Simulation Gamma 1 % Torque

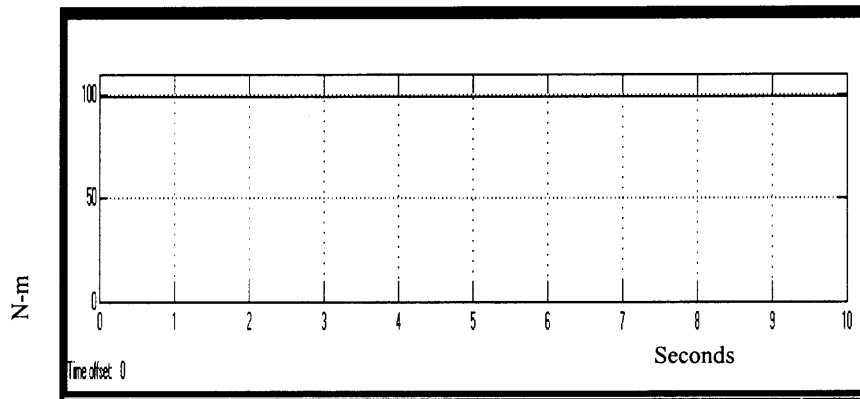

Figure 4.54.Tenth Simulation Gamma 1 % Basal Tone

The exponential growth of the basal tone contraction has now reached a value that maintains the system with limited mobility. The basal tone balances the torque produced by gravity at a non-zero angle.

The simulations allow identification of the influence of the torque exerted by the muscle contraction. Two main components have been identified so far: The intermittent isolated muscle contraction and the basal tone of muscle. As seen in the model this is a direct consequence of the interaction between alpha and gamma motoneurons. In the next chapter another factor, related to increased damping coefficient is discussed.

The model in this thesis could not be developed without a modern computer programming environment. The lack of such modeling tools has posed a great difficulty in previous interpretations of the Pendulum Knee Drop Test. In the next Chapter, we will discuss the significance of these results.

This thesis shows the models ranging from normal, through mild, moderate and severe spasticity progressing from underdamped dynamics to a critically damped, and finally to an overdamped system. However, this is not accomplished just by the merely altering the damping coefficient. It is accomplished by a complex interaction of the parameters

The model includes several non-linear contributing elements that can be controllers as a function of our hypothesized functions alpha/gamma imbalance.

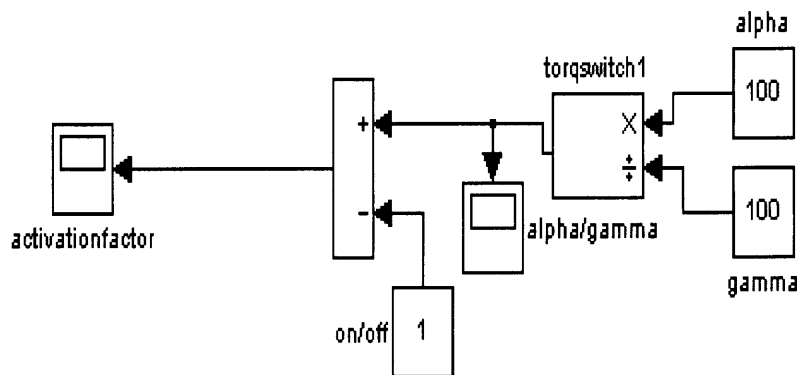

Figure 4.55. Alpha/Gamma activating function

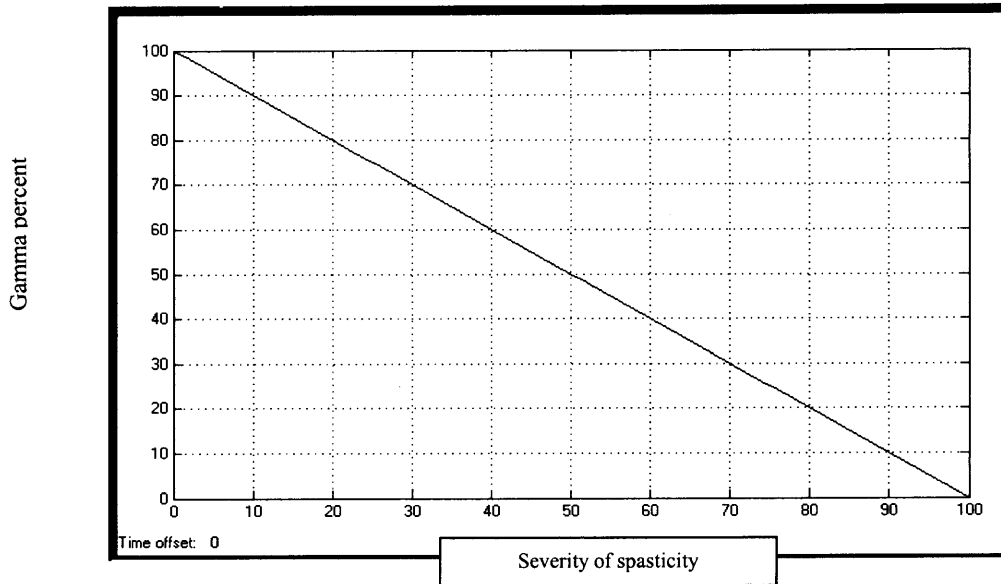

Figure 4.56. Decrement function of gamma

Graph showing a decremented function of gamma with a slope of one, as used in the simulation

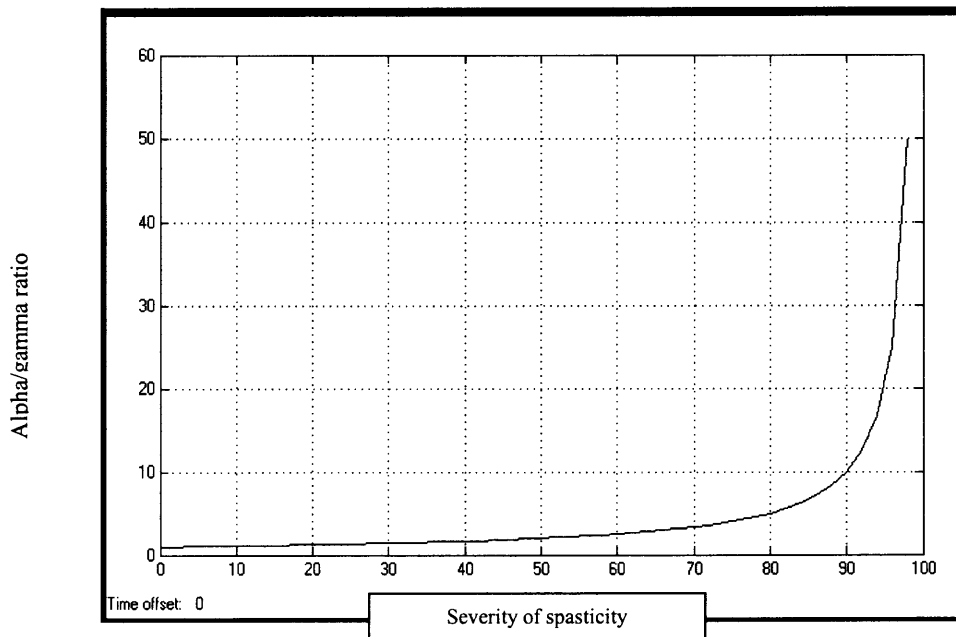

Figure 4.57. Alpha /Gamma relation as a function of severity of the spasticity

Graph corresponding to the Alpha /Gamma relation as a function of severity of the spasticity, showing clearly an exponential relation. Note starting point at a value of 1.

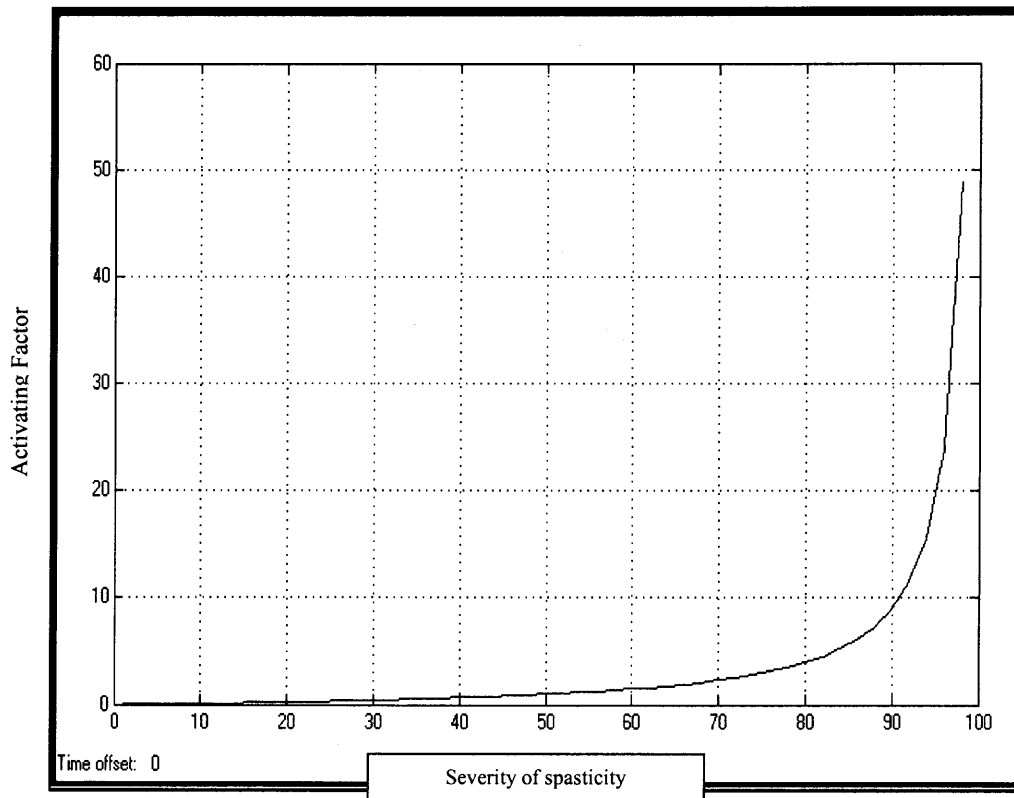

Figure 4.58. Activating factor as a function of severity of the spasticity

Graph showing the values of the activating factor, depicting an exponential curve starting at a value of zero.

The beta gain function is a very complex function to analyze. Overall it is expected to be increase as the muscle contraction increases. Additionally, there is a need for dissipation of the additional delivered energy.

During normal simulation it varies in a coordinated fashion with the velocity of theta being a fourth of its magnitude. However as the nonlinear activation intervenes and as the dynamics of the system grows in complexity, the variation also grows in complexity. The model takes the previously explained exponential function from alpha/gamma relation and multiplies it as a function of time creating a higher order

activation of the beta gain. The final response from the beta gain is related to and dependent upon velocity. This creates a surprisingly slow incremental function of beta in relation to velocity.

Preserving its parallel curve with velocity, its proportion will increase the beta gain as the gamma decreases. Starting from velocity/beta gain relation of 4/1 with a gamma at 100%. When gamma is at its 50% value the ratio velocity/beta gain is 2/1. When the gamma is at its 10% the beta gain value is larger than the velocity value with a relation of 1.2/1.5 and finally when gamma is at its 10% the velocity/beta gain ratio is inverted to a value of 0.2/1.2. As expected this increment is necessary when a change from an underdamped to a damped situation is encountered.

As the values of alpha/gamma vary, the relative contribution to the system from the two types of force input from the muscle varies in an inverse proportion.

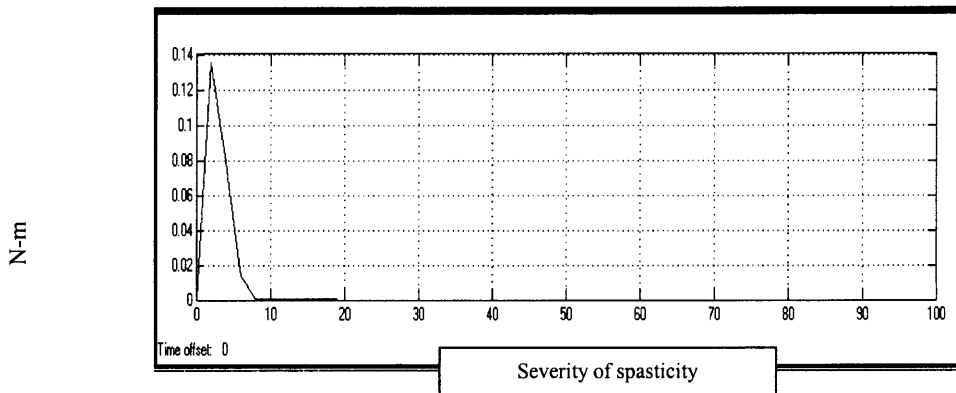

Figure 4.59. Muscle intermittent isolated torque contribution as function of alpha/gamma variation

As previously discussed, the main contribution from these intermittent isolated muscle activations is at the mild cases of spasticity. Contrasting to the advanced cases where a permanent augmented Basal Tone contribution is expected.

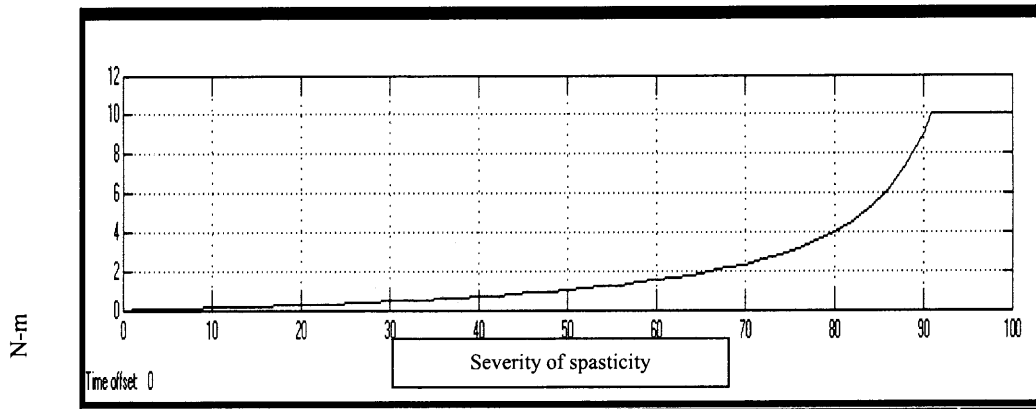

Figure 4.60. Muscle basal tone contribution as function of alpha/gamma variation

As a final consideration the graphs obtained by the model are going to be visually compared with some patient examples. The first is of a normal subject (fig. 4.61) compare it with the following figure of a normal model (fig. 4.62). In simulation graph it is well recognized the normal pattern.

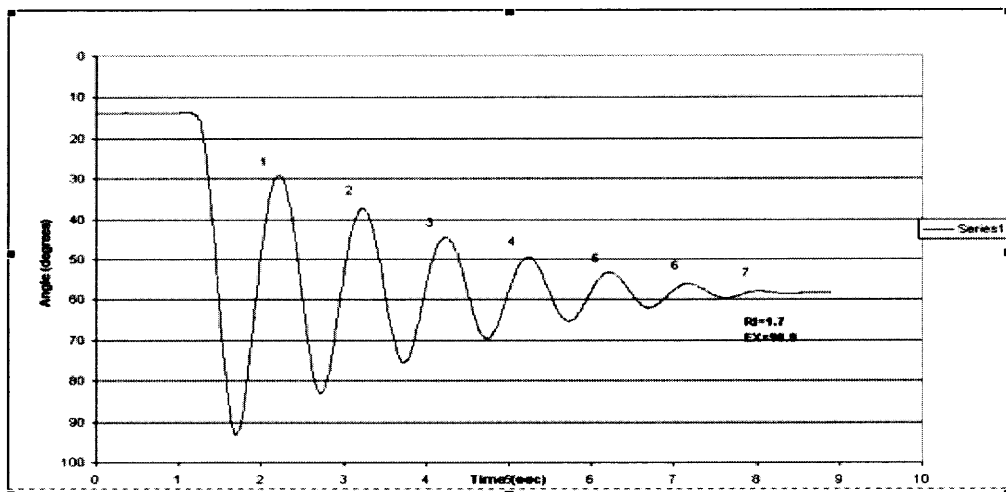

Figure 4.61. Normal Patient

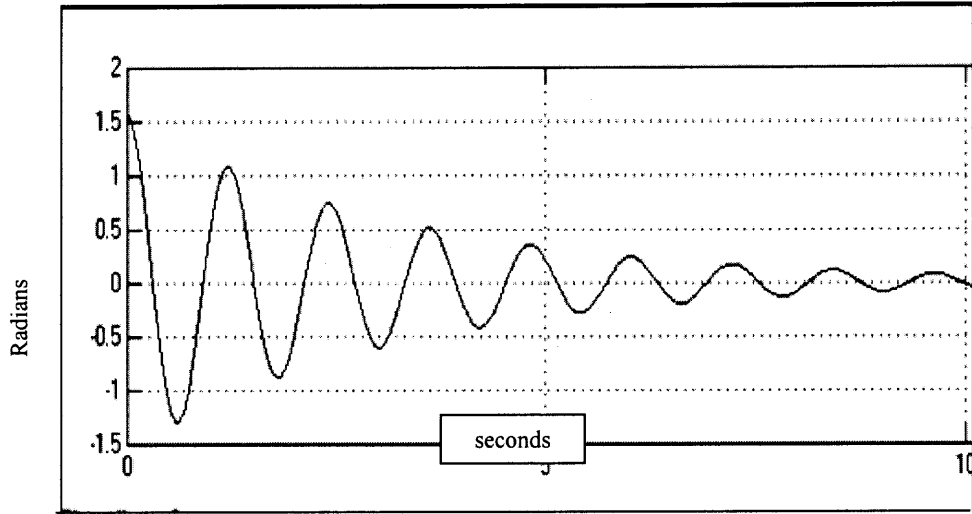

Figure 4.62. Normal Simulation

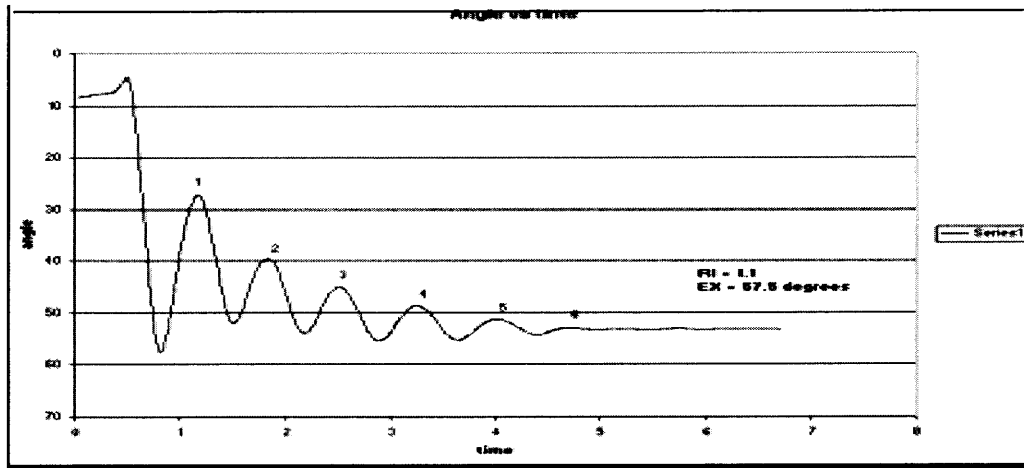

Figure 4.63. Mildly spastic patient

A previously discussed, the pattern of the spastic patient is determined not only by the amount of torque but also but the specific rate and time of muscle contraction onset. These two factors create a large variety of patterns. Even though, the next mild spastic patient illustrated in figure 4.63 has some common features with figure 4.64 as an example of a mild spastic simulation.

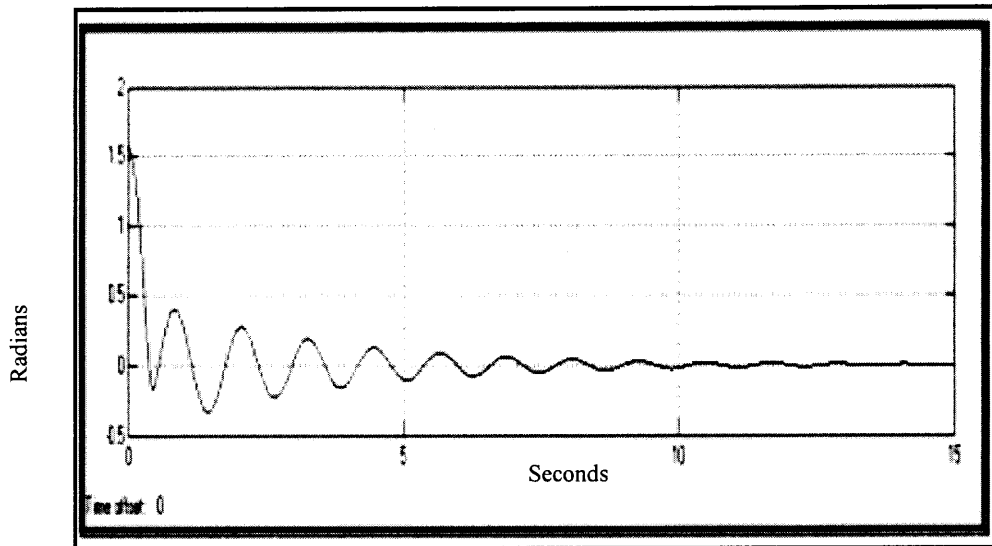

Figure 4.64. Mildly spastic simulation

The drop in the amplitude after the first half cycle is the most characteristic event in these type of patients due to the presence of an isolated muscle contraction of the quadriceps.

The next example, Figures 4.65 and 4.66, corresponds to a moderate to severe case of spasticity.

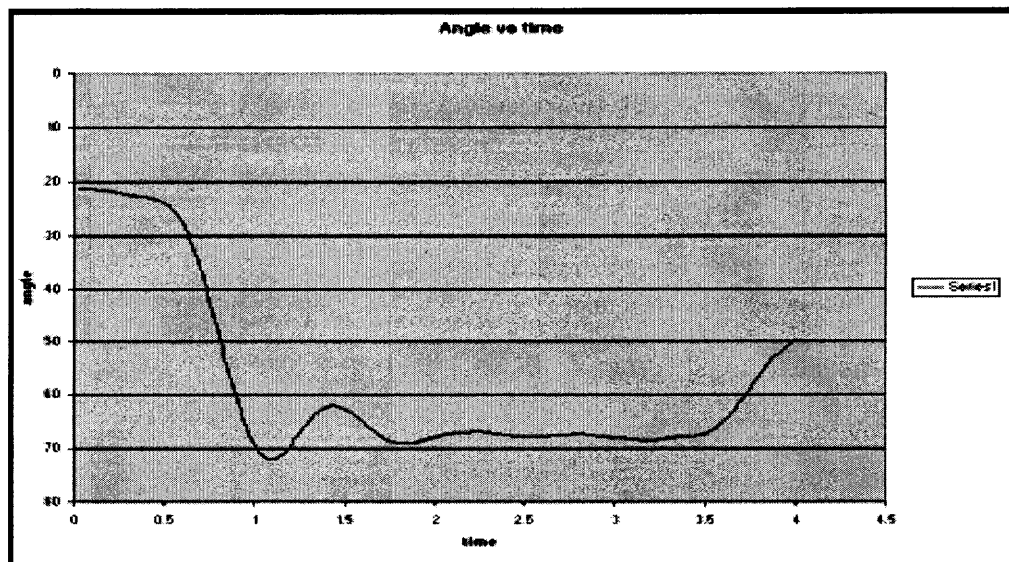

Figure 4.65. Moderate to severe spastic patient

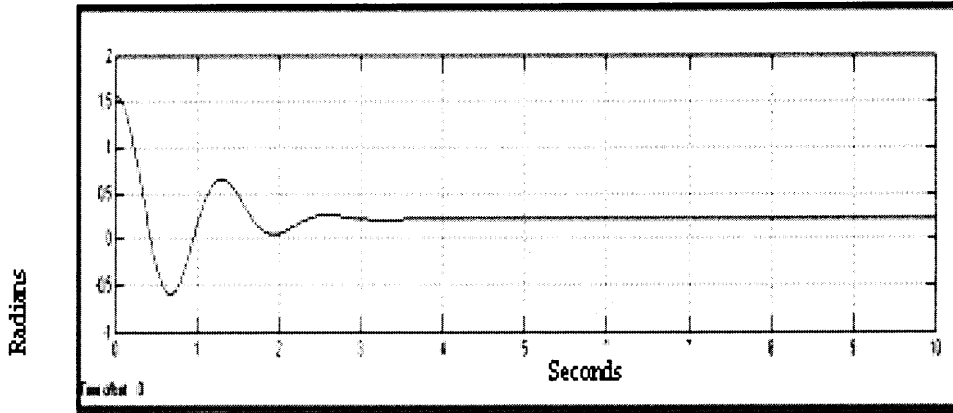

Figure 4.66. Moderate to severe spastic simulation

In figures 4.65 from a patient file and figure 4.66 from the model simulation, the most important aspect is that both have the morphology described for a critically damped system. Just one oscillation after the pendulum has been released. Notice the elevation of the equilibrium resting point from the normal gravitational vertical in both figures.

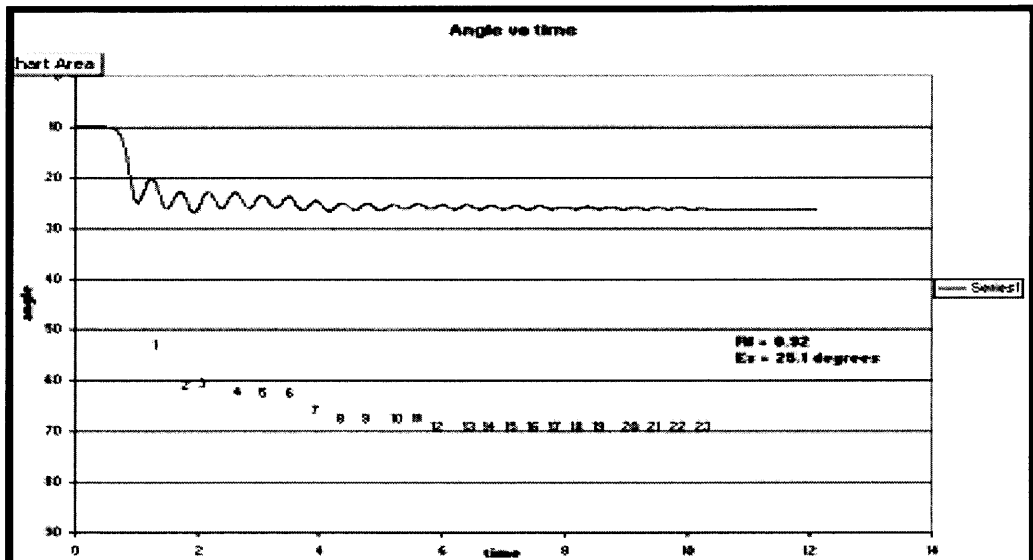

Figure 4.67. Severe spastic patient

Our last set of comparison will be done between a graph from a severely spastic patient and a graph from the model representing a similar condition. As seen on figures

4.67 and 4.68, now the system has acquired the characteristics of an overdamped system. No oscillation is perceived, and, the range of motion is very limited. The final resting equilibrium point is very displaced from the normal vertical gravitational.

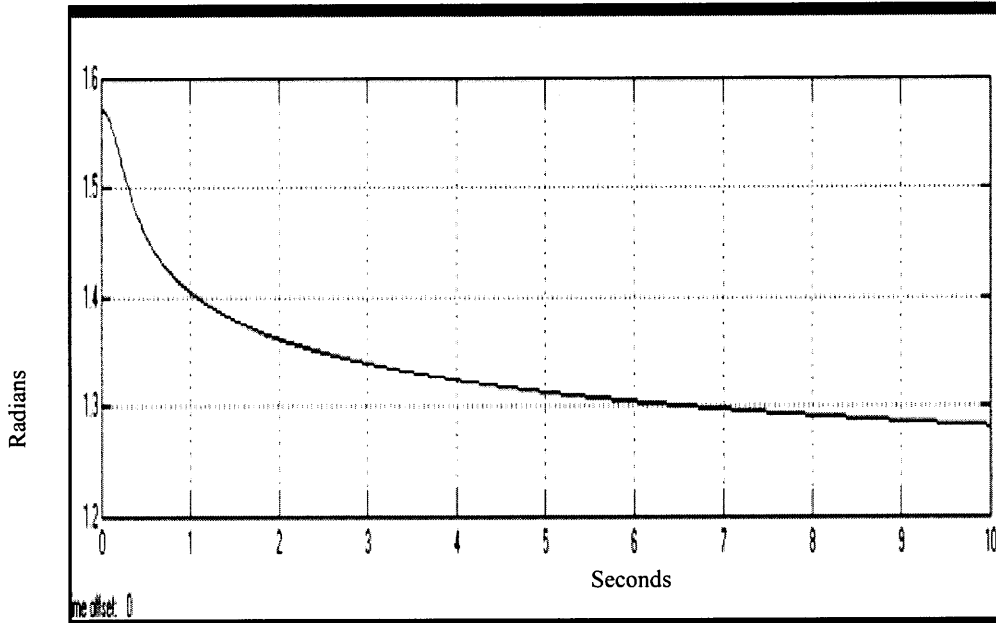

Figure 4.68. Severe spastic simulation

As it was explained earlier, the first set of graphs showing mild spasticity is the result of predominantly few isolated muscle contractions occurring at the beginning of the test. On the contrary, the last set of figures show a permanent force that impedes any type of displacement through the entire test. This permanent force is the result of a permanent muscle contraction that is clinically appreciable as a permanent hypertonic muscle.

CHAPTER 5

DISCUSSION

A starting point is very simple phrase for a huge concept. It implies that initial conditions and initial parameters are identified and described. This means that from these exact points onwards, the system behavior is predictable according to known limitations and boundaries. It is also implied that all or most of the unimportant factors have been disregarded.

Whenever a specific problem is to be analyzed there must be asset of initial conditions. There are different ways of accomplishing this task. Computer modeling has great advantages over some traditional approaches.

The model presented in this thesis deals with the analysis of the motor response, torque distribution, timing of the onset, duration, number and quality of the torques, grade of absorption and dissipation of the energy in a normal and a spastic subject during the implementation of a Pendulum Knee Drop Test.

Normally, as the inferior limb is released from the horizontal, gravity force will drive it to an equilibrium point define by gravitational vertical. As the limb has a joint at the knee it will behave as a pendulum. The muscle, and into a minor extent, the joint, ligaments, connective tissue and skin will gradually absorb the energy acting as a damper. The muscle and tendon also have recognized elastic properties by which they

store energy, but in a less comparative extent than its damping capacity. It is accepted that the system normally behaves as an underdamped oscillator.

When the normal neural regulation is lost, the spinal cord still exerts some incomplete and primitive type of control. This new way of functioning is incompletely understood. Nevertheless, certain facts are comprehended all based on the Sherrington's work on the stretch reflex.

The initial contribution towards understanding and measuring spasticity came from a clinician, Dr. Wartenberg. He made a very important observation regarding the pendular behavior of the leg, which is in fact the real starting point of this thesis. Wartenberg's work was primarily descriptive.

Biomedical engineering offers numerous attempts reported in the literature that address and analyzes, but few of them go deeply into causes of the muscle torques. This analysis is accomplished in the present study.

A computerized model gives us a great advantage in the process of understanding and implementing new strategies to quantify spasticity. When creating a model numerous possible parameters are identified. The challenge of modeling consists in the selection of the most representative of them.

A computerized model also allows to manipulate the different parameters even in extreme situations, usually impossible to achieve in real life. Moreover, it is possible to watch and study the progression and development of a system that is impossible to observe in a human environment.

By developing this model in a step-by-step approximation, we have identified three principal parameters that influence the spasticity seen in the pendulum knee drop

test. First, is that which increases the muscle contraction in an intermittent fashion, triggered by a complex relation between position, acceleration and velocity. The second is the one that establishes a continuously growing permanent muscle contraction or contractions, usually referred as “hypertonic muscle “ by the physicians, and a third changes the intrinsic physical muscle behavior, as a consequence of the interaction between their protein molecules, shifting it to a more energy absorbing structure.

As shown in the results chapter, the only way of achieving the full simulation of the different degrees of spasticity is by a complex interrelation among these three forces. These interactions are shown to have non-linear, exponential relationships

The first and most important results from the modeling of an unbalanced relationship between alpha and gamma motoneurons activation. The second, who is derived from the first and involves the basal muscle tone that increases as gamma value decreases. The third is the influence that the intermittent isolated muscle contraction forces plays on at the beginning of the unbalanced relation between alpha and gamma, as well as how it decreases in importance as the severity of spasticity increases. It also regulates the amplitude of the spastic contraction in a decaying exponential delivery of the torque force as a function of time.

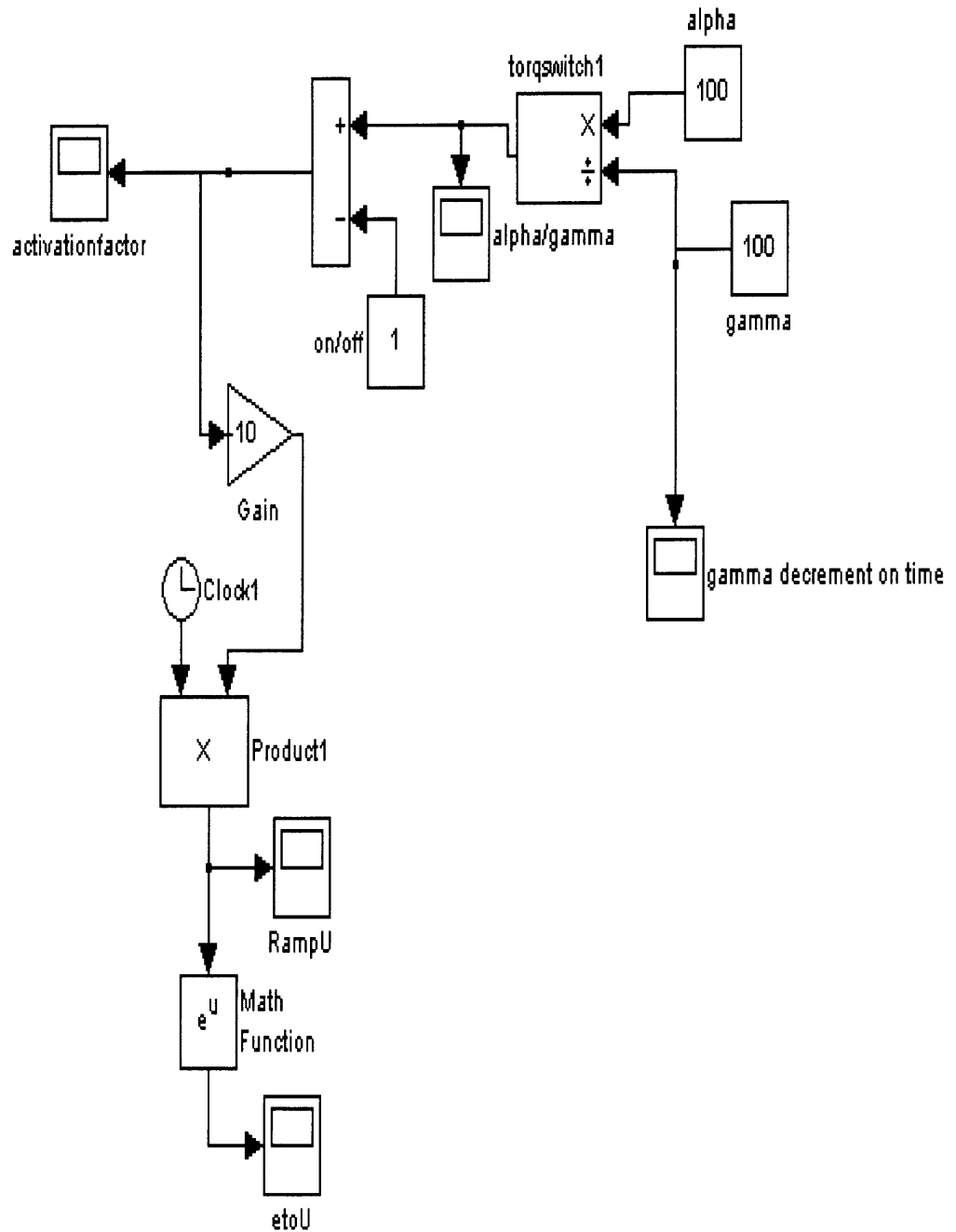

Figure 5.1. Basal tone regulating function

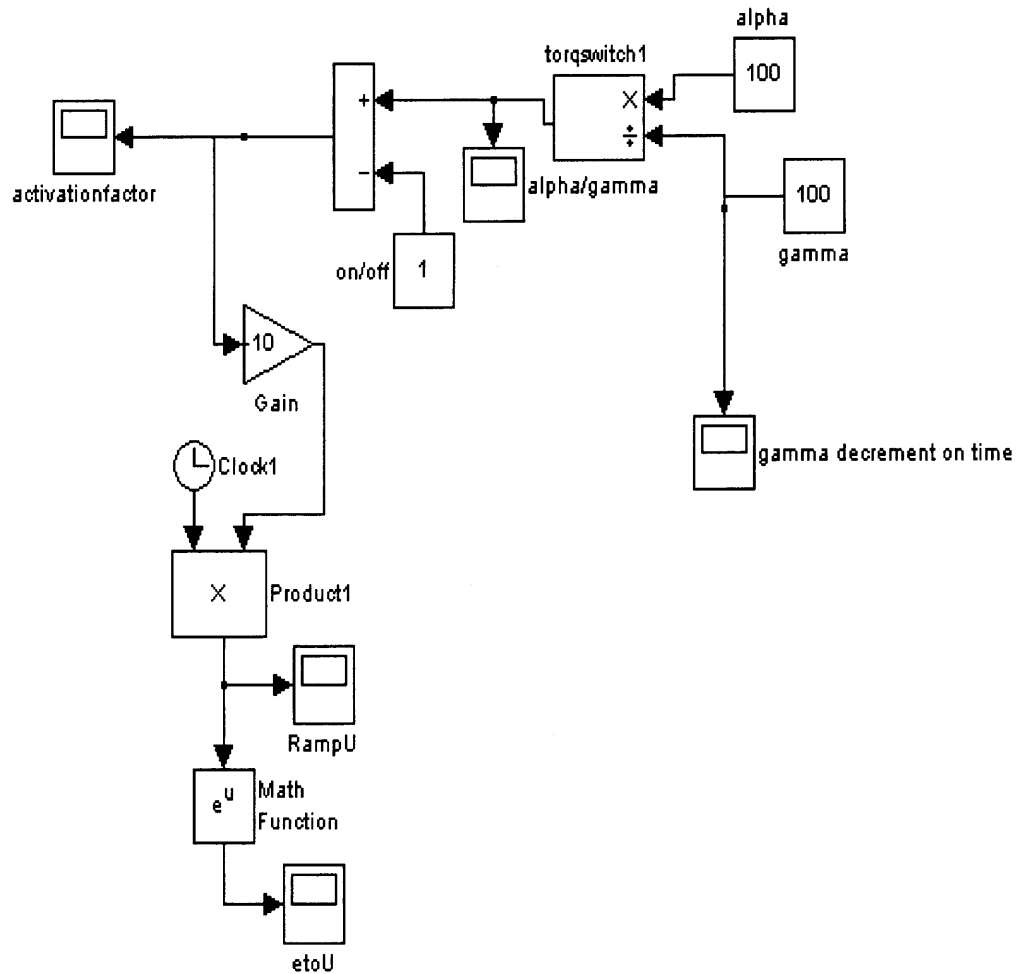

Figure 5.2. Intermittent muscle contraction regulating function

By having all three in conjunction, the entire muscle torque is regulated. But the timing, which is important mainly in the non-severe cases of spasticity where the muscle contraction is not permanent, and is regulated by an interaction between the values of the cosine of theta and the absolute values of a negative sine of theta. As it has been already explained, the change in the Pendulum Knee Drop Test dynamics resides in the way these forces are delivered and transferred.

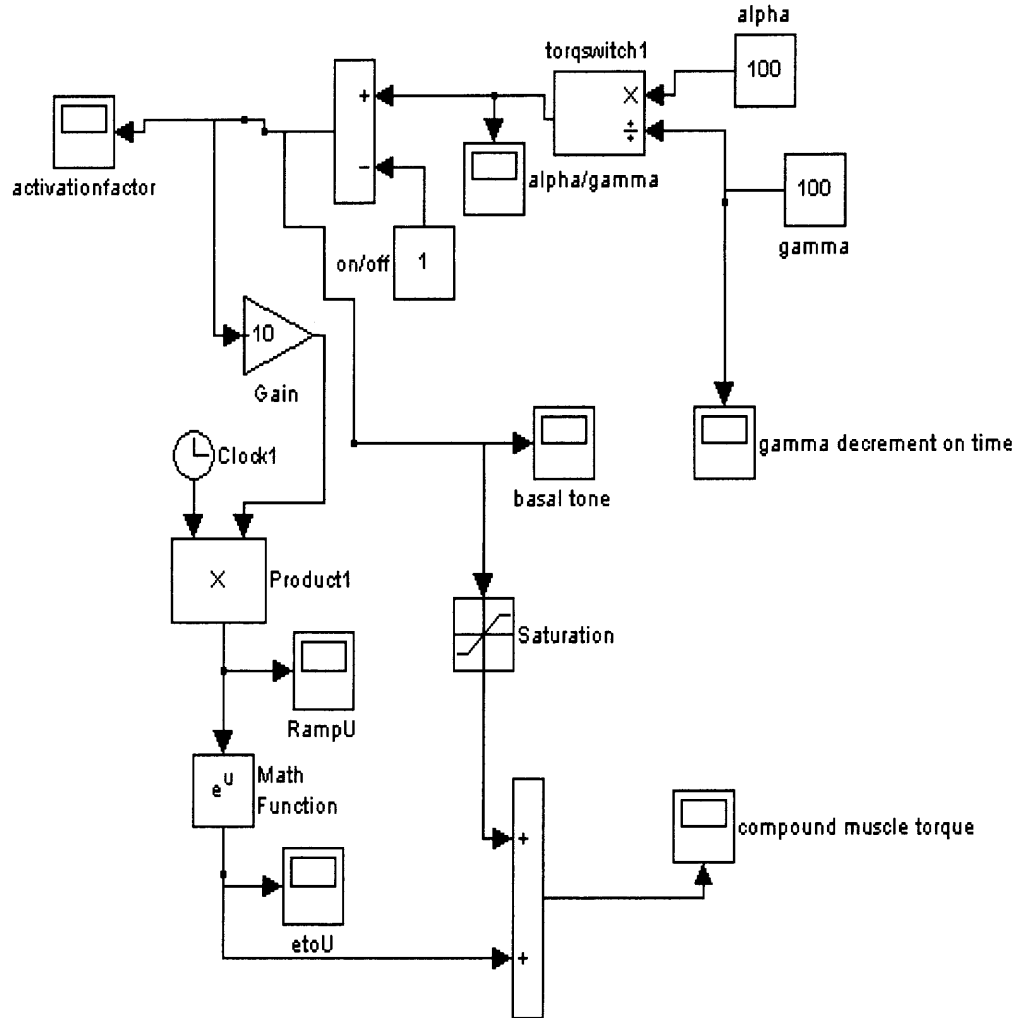

Figure 5.3. Integrated muscle switch regulation

The figure 5.4 shows the way the Activation Factor (AF) increases as the gamma function decreases as already described in an exponential way. This AF will influence the force production and force transference to the system

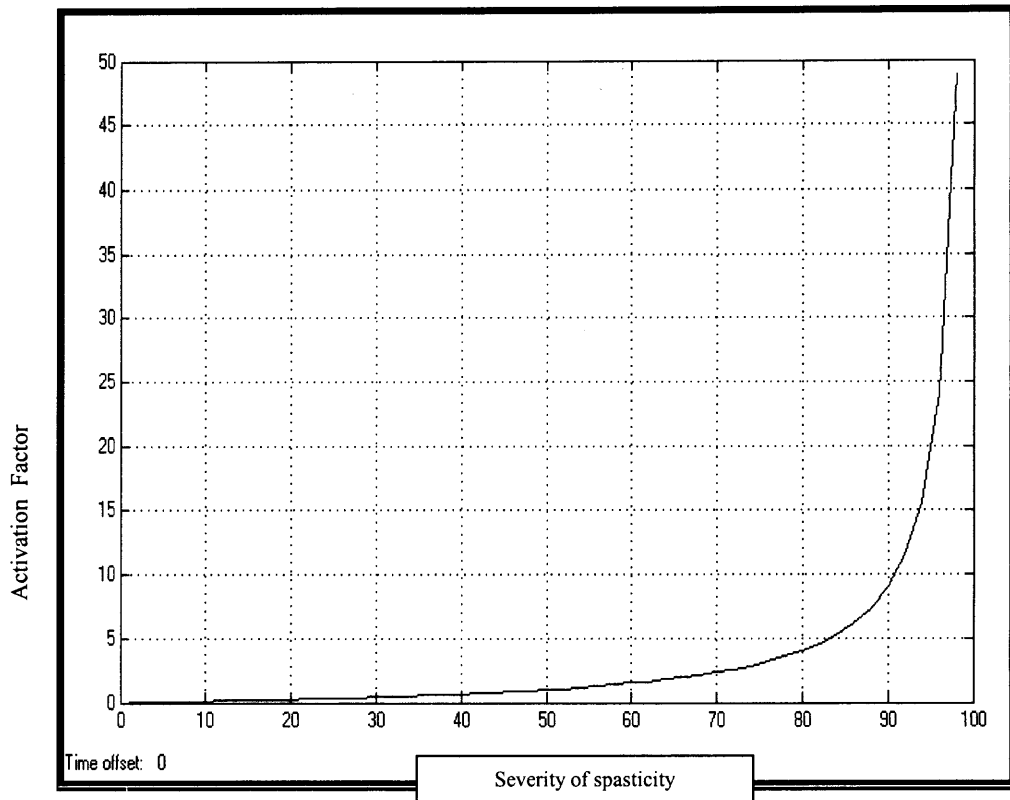

Figure 5.4. Activation factor as a function of gamma decrement

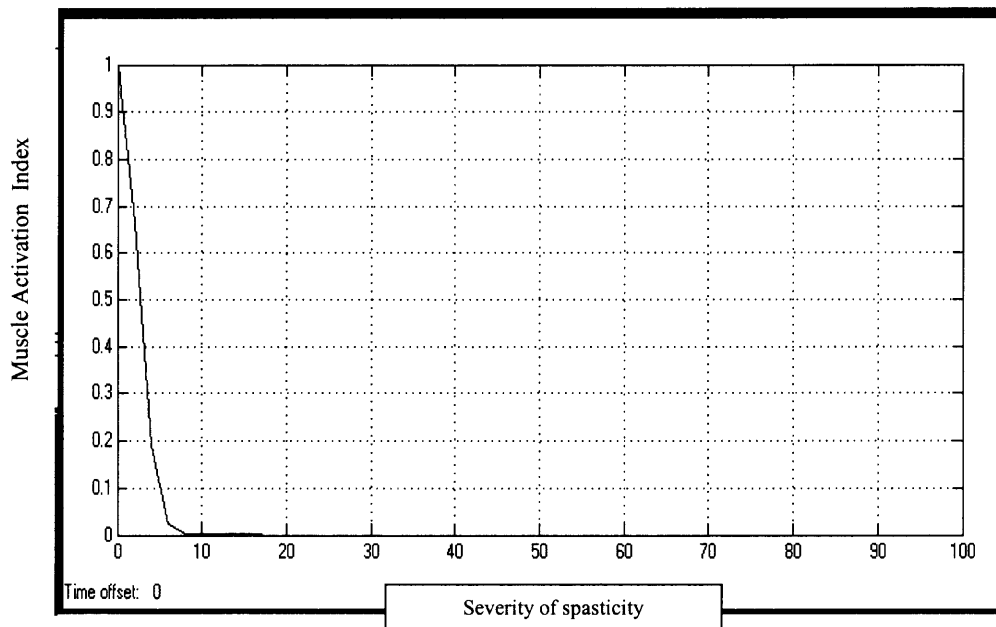

Figure 5.5. Isolated muscle activation as a function of gamma decrement

Up to the present no model has described the spastic dynamics of the Pendulum Knee Drop Test using the imbalance between the alpha and gamma signals.

The model makes a contribution by opening new possibilities in terms of spasticity and development of an index of severity. The fact that energy expenditure (i.e. opposite contractions torque) is accomplished by the addition of the additional torque and simulates mild to a severe spasticity, focuses the attention on both muscle torque components and on the parameters that trigger those intermittent torque. Nevertheless, the change on the damping coefficient cannot be forgotten or overlooked. Conversely, the increment on the spring –elastic- coefficient, although present, does not seem to be very important in the evolving dynamics.

One way of accurate measuring the spasticity is measuring the added energy or force and compared to the normal values.

CHAPTER 6

FINAL CONSIDERATIONS

Numerous definitions of spasticity are found that come from an exclusively medical point of view:

“Spasticity is a change in the normal dance between muscles that usually work together or work in opposition to make limbs smooth,” Dr. Juan De Lecuona, Medical College of Georgia neurologist and psychiatrist. [27]

“As mentioned previously, Spasticity is defined as increased resistive force for a particular muscle group to passive movement.” [2]

“Spasticity is a motor disorder characterized by a velocity-dependent increase in tonic stretch reflexes with exaggerated tendon jerks, resulting from hyperexcitability of the stretch reflex, as one component of the upper motor neuron syndrome.” [29]

From a combined physiological and engineering perspective this thesis proposes that spasticity can be defined as a system resulting from an uncoupled disharmonic alpha/gamma motor control that creates a very inefficient and diminished movement with a high force delivery. In this definition, a high energy transfer is implied.

To date medicine and allied disciplines have approached their normal and altered patients by the semiological and regular procedure of inspection, palpation and auscultation.

After, the information is gathered by these three different senses, it integrated into a cognitive model describing the actual patient condition. The physician compares this image with other models they have experienced.

In order to remove the subjectivity associated with these models, medical science has sought various reference frames. Among these are observational scales that are of limited use since they are merely descriptive. However questions arise: Are they accurate? Are they reproducible? Are they even comparable between two different examiners? Are they able to measure all that is important? Are the sensitive enough to identify the parameters that define the outcome?

Spasticity is not a static parameter and simple measures such as the Ashworth Scale do not fully describe its dynamic nature. This study has addressed the study of spasticity using engineering non-linear models and powerful dynamic modeling software.

The contributions of this work are:

- 1) A new definition for spasticity from a dynamics point of view.
- 2) Anew computer model for studying and simulating spasticity
- 3) Selection and definition of parameters that will explain better the spastic phenomena.
- 4) Explanation of the dynamics of the energy transfer that provides active damping to passive the system.
- 5) Identification of fundamental parameters for a systematized and standardized approach to the measurement of spasticity.
- 6) Use these parameters to propose a way to measure and quantify it.

- 7) Demonstration of the measurement and quantifying of spasticity using these parameters.

When using a computer model we do not need to find strict numerical solutions in order to simulate a non linear system. We have identified the inclusion of a higher energy input, derived not from the usual gravity influence that normally drives the system, but delivered by the spastic muscle contraction. This is a very important event in with mild spasticity. So, by measuring acceleration it will allow us to measure the muscle energy contribution in non-severe cases.

From a dynamics point of view, we can be define spasticity as a phenomenon resulting from an uncoupled, disharmonic alpha/gamma motor control that creates a very inefficient and diminished movement with a high force delivery. In this definition, it is implied a high energy transfer. Regardless of the underlying etiology of the spastic phenomenon, it creates an alteration of the motor control mechanism. This alteration is reflected in an improper movement pattern.

This movement pattern is characterized by a considerable amount of muscle energy. The intended movement is non- harmonic, unbalanced and exuberant, and, inefficient as a result of the cocontraction of antagonist pairs.

In summary, there is a very high amount of energy invested and yet a very little amount of movement is achieved. Obviously it is implied that the main cause is an underlying altered neuro- control mechanism. In this way we make a difference between the impaired motion caused by other type of lesions like arthritis, or arthrodesis or muscle retractions or muscle fibrosis.

As a consequence, any spasticity study must focus in the amount of energy delivered by the muscle and in the amount of movement achieved. In this model it has been identified that the energy delivered by the spastic muscle results in three outcomes.

Isolated intermittent muscle contraction is predominantly influences the dynamics changes in the pendular trajectory in the less severe cases of spasticity where the permanent muscle contraction is insignificant.

Basal tone muscular contraction results in a permanent or nearly permanent contracture altering the equilibrium point from the normally expected gravitational vertical and occurs predominantly in more severe cases.

And as a consequence of this muscle contraction the muscle fiber proteins slide inside each other so they have more “cohesive force”, as a result they have a larger damping coefficient. Thus the damping coefficient changes during spastic muscle contraction.

Being these parameters identified, there is needed a way to quantify them. The amount of energy delivered by the muscle is essentially delivered as force In normal people this energy will be transduced into acceleration and velocity. We have modeled each of these contributions in the final model.

This work has deal only with computer models of hypothetical person whose alpha/gamma imbalance can be changed to observe the potential deviation in this pendular trajectory of the leg. These trajectories have been subjectively compared with trajectories of subjects with no, mild, moderate and severe spasticity. Additional work should include the study of specific individuals and use this model to produce their alpha/gamma ratio based upon their experimental measured limb trajectories.

REFERENCES

1. Atkinson, P., Atkinson, J. 1996. "Spinal Shock". *Mayo Clin. Proc.* 71: 384-389.
2. Bajd, T., Vodonik, L. 1984. "Pendulum testing of spasticity." *J. of Biomedical Eng.* Jan: 9-18.
3. Barker, J.A. 1995. *Paradigmas* . Bogota: McGraw-Hill
4. Boczko, M. and Mumenthaler, M.1958. "Modified pendulousness test to assess tonus of thigh muscles in spasticity." *Neurology* 8: 846-851.
5. Bohannon, R.X., Smith, M.B. 1987. "Interrater reliability of a modified Ashworth scale of muscle spasticity." *Physical Therapy* 67(2): 206-207.
6. Burchiel, K.J., Hsu, F.K. 2001. "Pain and Spasticity After Spinal Cord Injury." *Spine* 26: S146–S160.
7. Burke, D., Gillies, J.D., Lance, J.W. 1970. "The quadriceps stretch reflex in human spasticity." *J. Neurol. Psychiat.* 33: 216-223.
8. Burke, D., Gillies, J., Lance, J. 1971. "Hamstrings stretch reflex in human spasticity." *J. Neurol. Neurosurg. Psychiat.* 34: 231-235.
9. Bustamante, J. 1996. *Neuroanatomia Funcional*. 2 ed. Bogota: Celsius.
10. Crago, P. 2000. "Creating Neuromusculoskeletal models." In *Biomechanics and neural control of Posture and movement*. Winters, J., Crago, P. (eds.) Chapter 8. New York: Springer Verlag.
11. Downes, L. 1995. "Reflex effects from Golgi tendon organ (Ib) afferents are unchanged after spinal cord lesions in humans." *Neurology* 45(9): 1720-1724.
12. Faist, M., Ertel, M., Berger, W., Dietz, V. 1999. "Impaired modulation of quadriceps tendon jerk reflex during spastic gait: differences between spinal and cerebral lesions." *Brain* 122: 567–579.
13. Fee, J. and Foulds, R. 2002. "Optimization Computer Algorithm For EMG Activation On Pendulum Knee Drop Test Of Spastic Patients." Personal communication.
14. Feynman, R. 1963. "Transients." In: *The Feynman Lectures on Physics* (1) 24:1-15. New York: Addison- Wesley Publish. Co.
15. Fowler, et. al. 2000. "Sensitivity Of The Pendulum Test For Assessing Spasticity In Persons With Cerebral Palsy." *Dev. Med. & Child Neurol.* 42: 182 –189.

16. Fowler, E. 2001. "The Effect of Quadriceps Femoris Muscle Strengthening Exercises on Spasticity in Children With Cerebral Palsy." *Phys. Ther.* 81: 1215-1223.
17. Holt, K. 1990. "The forced driven harmonic oscillator as a model for human locomotion." *Human movement science* 9: 55-68.
18. Jordan, L. (1993, March). Basic science and clinical studies on functional systems of the spinal cord: Update on research in the Spinal Cord Research Centre. <http://www.scrc.umanitoba.ca/SCRC/articles/manmed93/jordan.html>(1 March 2002).
19. Kita, M. (1999, August 10). Treatment Of Spasticity. <http://mscenter.his.ucsf.edu/lecture/4/lecture.html> (15 February 2002).
20. Knutsson, E., Mårtensson, A., Gransberg, L. 1997. "Influences of muscle stretch reflexes on voluntary, velocity-controlled movements in spastic paraparesis." *Brain* 120: 1621-1633.
21. Leis, A.A. 1996. "Spinal motoneuron excitability after acute spinal cord injury in humans." *Neurology* 47: 231-237.
22. Lin, D., Rymer, W. 1991. "A quantitative analysis of pendular motion leg in spastic human subjects." *IEEE Tran. Biomed. Eng.* 38: 906-918.
23. Lin, Z., Rymer, W. 1997. "Simultaneous non linear identification of mechanical and reflex properties of human elbow joint muscles." *IEEE Trans. Biomed. Eng.* 44: 1192-1209.
24. Marchese, S. 2001. "The spasticity evaluation test (SeT): A pilot study." *Journal of Rehabilitation Research and Development* 38 (1): 1124-1132.
25. Mazzocchio, R., Rossi, A. 1997. "Involvement of spinal recurrent inhibition in Spasticity." *Brain* 120: 991-1003.
26. McMahon, T. 1984. "Mechanics of locomotion." *International Journal Robot Research* 3: 4-28.
27. Medical College of Georgia. (1997, November 17). Spasticity service established for patients with disabling changes in muscle tone. <http://www.mcg.edu/news/97NewsRel/spasticity.htm>(12 Feb.2002).
28. Pandyan, A.D., Johnson, G. 1999. "A review of the properties and limitations of the Asworth and modified Ashworth scales as measures of spasticity." *Clinical Rehab.* 13: 373-383.

29. Pierson, S.H. 1997. "Outcome Measures in Spasticity Management." *Muscle Nerve* 20 (suppl 6): S36-S60.
30. Roth,G. 1982. "The origin of fasciculations." *Ann. Neurol.* 12: 542-547.
31. Schwab, R.S. 1964. "Problems in the clinical estimation of rigidity hypertonia." *Clin. Pharm. Ther.* 5: 942-946.
32. Smith, A.W., Jamshidi, M., Lo, S.K. 2002. "Clinical Measurement of Muscle Tone Using a Velocity-Corrected Modified Ashworth Scale." *Am. J. Phys. Med. Rehabil.* 81: 202–206.
33. Simonsa, D.G., Menseb, S. 1998. "Understanding and measurement of muscle tone as related to clinical muscle pain." *Pain* 75: 1–17.
34. Smyth, M., Peacock, W. 2000. "The Surgical Treatment Of Spasticity." *Muscle Nerve* 23: 153–163.
35. The School of Health Professions at the University of Southampton. (2000, October 12). Notes on Spasticity. [http://www.sohp.soton.ac.uk/neuro/Undergrad 20Notes% 20 on%20Spasticity.htm](http://www.sohp.soton.ac.uk/neuro/Undergrad%20Notes%20on%20Spasticity.htm) (1 March 2002).
36. Van der Helm, F. 2000. "Planning of human motions: how simple must it be?" In *Biomechanics and neural control of Posture and movement*. Winters, J., Crago, P. (eds.) Chapter 29. New York: Springer Verlag.
37. Van der Helm, F. 2000. "Musculoskeletal systems with intrinsic and proprioceptive feedback." In *Biomechanics and neural control of Posture and movement*. Winters, J., Crago, P. (eds.) Chapter 11. New York: Springer Verlag.
38. Vodovnik, L., Bowman, B., Bajd, T.1984. "Dynamics of Spastic Knee Joint ." *Medical & Biol. Eng. & Comp.* 22: 63-69.
39. Vodovnik, L. 1981. "Effect of electrical stimulation on hypertonia." *Annual Reports of Progress, Rancho Los Amigos REC*, Downey, California. 46-81.
40. Wartenberg, R. 1951. "Pendulousness of the legs as a diagnostic test." *Neurology* 1: 18-24.
41. Winter, D.A.1990. " *Biomechanics and motor control of human movement.*" New York: Wiley Interscience Publications
42. Winters, J. 2000. "Subtle nonlinear Neuromuscular properties are consistent with teleological design properties." In *Biomechanics and neural control of Posture and movement*. Winters, J., Crago, P. (eds.) Chapter 7. New York: Springer Verlag.

43. Winters, J. 2000. "Terminology and foundations of movement science." *In Biomechanics and neural control of Posture and movement*. Winters, J., Crago, P. (eds.) Chapter 1. New York: Springer Verlag.