

Copyright Warning & Restrictions

The copyright law of the United States (Title 17, United States Code) governs the making of photocopies or other reproductions of copyrighted material.

Under certain conditions specified in the law, libraries and archives are authorized to furnish a photocopy or other reproduction. One of these specified conditions is that the photocopy or reproduction is not to be “used for any purpose other than private study, scholarship, or research.” If a user makes a request for, or later uses, a photocopy or reproduction for purposes in excess of “fair use” that user may be liable for copyright infringement,

This institution reserves the right to refuse to accept a copying order if, in its judgment, fulfillment of the order would involve violation of copyright law.

Please Note: The author retains the copyright while the New Jersey Institute of Technology reserves the right to distribute this thesis or dissertation

Printing note: If you do not wish to print this page, then select “Pages from: first page # to: last page #” on the print dialog screen

The Van Houten library has removed some of the personal information and all signatures from the approval page and biographical sketches of theses and dissertations in order to protect the identity of NJIT graduates and faculty.

ABSTRACT

ANALYSIS OF LONG-TERM HEART RATE VARIABILITY USING LABVIEW

by
Daniel Yang

Long-term heart rate variability measurement is important in understanding the activities of the autonomic nervous system. Many methods and implications of long-term HRV were available in the literature. The first two studies focused on two data analysis techniques that were used on a normal subject. The first study focused on the $1/f$ fluctuations. For this analysis, three 1h heart rate variability data sets were collected with the Polar Vantage NV. A LabVIEW program was used to calculate the power spectrum of the heart rate, and then the $1/f$ line was calculated by taking the log of the power spectrum versus the log of the frequency. The second study focused on the 24h circadian rhythm characteristics from the low frequency and high frequency portions of the HRV spectrum. The same watch was used to collect three 22h heart rate variability data sets. The 22h data sets were divided into 15min segments. The same computer algorithm was used to calculate the low and high frequency portions of the power spectrum. The plot of the low frequency and high frequency versus time was determined

The third study focused on the non-linear dynamics of the HRV. For this analysis, fifteen long-term ECG data sets were collected with the Polar NV watch from 2 cardiac patients and 3 healthy subjects. 1h interval was obtained from each data set, and each data set was analyzed using the Benoit 1.1 R/S analysis program and the LabVIEW standard deviation program. The results showed that in normal subjects at rest, the $1/f$ fluctuation was observed and the 2-hour circadian rhythm was present. The non-linear dynamics of HRV was useful in separating the healthy from the cardiac patients.

ANALYSIS OF LONG-TERM HEART RATE VARIABILITY USING LABVIEW

by
Daniel Yang

**A Master's Thesis
Submitted to the Faculty of
New Jersey Institute of Technology
in Partial Fulfillment of the Requirements for the Degree of
Master of Science in Biomedical Engineering**

Biomedical Engineering Committee

August 1999

APPROVAL PAGE

ANALYSIS OF LONG-TERM HEART RATE VARIABILITY USING LABVIEW

Daniel Yang

Dr. Stanley Reisman, Thesis Advisor Date
Professor of Electrical and Computer Engineering,
Director of Biomedical Engineering, NJIT

Dr. John Tavantzis, Committee Member Date
Professor of Mathematics, NJIT

Dr. Ronald Rockland , Committee Member Date
Assistant Professor of Electrical Engineering Technology, NJIT

BIOGRAPHICAL SKETCH

Author: Daniel Yang
Degree: Master of Science
Date: August, 1999

Undergraduate and Graduate Education:

- Master of Science in Biomedical Engineering,
New Jersey Institute of Technology, Newark, NJ, 1999
- Bachelor of Science in Engineering Science,
New Jersey Institute of Technology, Newark, NJ, 1998

Major: Biomedical Engineering

To my Messiah, Yeshua, and my beloved family: mom, Faith, and Dong.

ACKNOWLEDGMENT

I would like to express my deepest appreciation to Dr. Stanley Reisman for his invaluable guidance, providing countless resources, insight and inspiration. Also special thanks to Mr. Zafer Sahinoglu for his help with LabVIEW programming.

I would like to thanks all my friends at Peer Counseling for all their support. I thank my friends at IV and CCF for just being friends, especially Richard Chon, Aaron Ko, and Yash Sinha. I thank my friends at Church of New York Chinatown for putting up with my many absences, which added extra burdens to them. Also, I thank Dr. Tavantzis and Dr. Rockland for being members of my thesis committee.

TABLE OF CONTENTS

Chapter	Page
1. INTRODUCTION.....	1
1.1 Objective	1
1.2 Background Information	2
1.2.1 Anatomy and Function of the Heart.....	2
1.2.2 Making an ECG Measurement.....	6
1.3 Literature Review.....	12
1.3.1 Heart Rate Variability(HRV).....	12
1.3.2 1/f	17
1.3.3 Circadian Rhythm.....	21
1.3.4 Non-linear Dynamics.....	23
2. METHODS	28
2.1 Data Acquisition	29
2.1.1 Watch Functions.....	29
2.1.2 Changing the Recording Interval	31
2.1.3 Study Protocol.....	32
2.2 Preprocessing.....	35
2.3 LabVIEW Algorithm.....	37
2.4 Benoit Program.....	40
3. RESULTS	43
3.1 Study 1:1/f Results.....	43
3.1.1 Study 1: 1/fRR Results.....	43

TABLE OF CONTENTS
(Continued)

Chapter	Page
3.1.2 Study 1: 1/f 5sec Results.....	46
3.2 Study 2: Circadian Rhythm Results.....	48
3.3 Study 3: Non-linear Dynamics.....	50
4. CONCLUSIONS AND FUTURE STUDIES	54
APPENDIX A HRV RESULTS FROM POLAR WATCH RESEARCH.....	57
APPENDIX B POLAR WATCH FUNCTIONS.....	60
APPENDIX C RAW DATA TO NOISE DELETION.....	66
APPENDIX D LABVIEW ALGORITHM.....	76
APPENDIX E RESULTS FROM LABVIEW & MS EXCEL.....	82
REFERENCES	89

LIST OF TABLES

Figure	Page
1.1 Polar HRV Results.....	15
2.1 Recording interval alternatives	31
3.1 1/f results: RR2 regression line	44
3.2 1/f results: RR3 regression line	44
3.3 1/f results: RR1 regression line	45
3.4 1/f results: 5sec1 regression line	46
3.5 1/f results: 5sec2 regression line	46
3.6 1/f results: 5sec3 regression line	47
3.7 Non-linear dynamics: 1h(720pts.)	50
3.8 Non-linear dynamics: 1/2h(720pts.)	52

LIST OF FIGURES

Figure	Page
1.1 The conduction system of the heart	3
1.2 Standard notation for leads I,II,&III	4
1.3 The electrical active regions of the heart	4
1.4 Dipole moment and cardiac vector	6
1.5 Frontal plane: lead I,II,&III	7
1.6 Frontal Plane: augmented leads	8
1.7 Transverse plane: 6 precordial leads	9
1.8 Atrioventricular(AV) block	10
1.9 Premature ventricular contraction(PVC)	10
1.10 Paroxysmal tachycardia & atrial flutter	11
1.11 Atrial fibrillation & ventricular fibrillation	11
1.12 Heart rate: normal subject	13
1.13 Heart rate: severe diabetic neuropathy	13
1.14 Power spectrum: normal subject	13
1.15 Power spectrum: subject under stress	13
1.16 $1/f$ in the range 0.00003-0.1Hz.....	18
1.17 Locked-in syndrome patient	19
1.18 Creutzfeldt-Jakob disease (CJD)	20
1.19 Brain dead patient	21
1.20 LF & HF vs. time plots.....	22

**LIST OF FIGURES
(Continued)**

Figure	Page
1.21 Standard deviation measurement	24
1.22 Fractal measure: beta	25
2.1 Polar Vantage NV parts	28
2.2 Watch functions	29
2.3 Watch-interface system	30
2.4 Wearing the heart rate monitor(HRM)	31
2.5 Raw 5s interval recording	34
2.6 Cleaned text file	35
2.7 Standard deviation VI: front panel	37
2.8 Standard deviation VI: diagram	37
2.9 HR power spectrum: left side of diagram	38
2.10 Benoit program: file 1027a R/S analysis	40
3.1 RR2: Log(Power) vs. Log(freq)	43
3.2 RR3: Log(Power) vs. Log(freq)	44
3.3 RR1: Log(Power) vs. Log(freq)	45
3.4 5sec1: Log(Power) vs. Log(freq)	46
3.5 5sec2: Log(Power) vs. Log(freq)	47
3.6 5sec3: Log(Power) vs. Log(freq)	47
3.7 Circadian rhythm: 1 st day to 2 nd day	48
3.8 Circadian rhythm: 2 nd day 12am-6pm	49

LIST OF FIGURES
(Continued)

Figure	Page
3.9 Circadian rhythm: 3 rd day 1am-12midnight.....	49
3.10 Circadian rhythm: 3 rd day to 4 th day 12noon.....	49
3.11 Fractal measurement: beta(1h)	51
3.12 Variability measurement: standard deviation(1h).....	51
3.13 Variability measurement: standard deviation(1/2h)	52
3.14 Fractal measurement: beta(1/2h)	53

CHAPTER 1

INTRODUCTION

1.1 Objective

The goal of this project is to analyze long-term heart rate variability (HRV). In the literature, there have been many studies done in the area of long-term HRV, particularly 1/f, circadian rhythm and non-linear dynamics. The literature cited the methods and their implications. It is our goal to apply their techniques and reproduce their findings.

Long-term HRV recording and analysis are important in understanding the activities of the autonomic nervous system (the sympathetic and the parasympathetic nervous systems) over a 24h period. Long-term HRV application in clinical situations has been proven crucial. With continuous (long-term) ECG recordings, physicians can see how their patients are doing on the operating table and during recovery, and by using continuous ECG and heart rate, physicians can detect early the killer cardiac arrhythmias for patients suffering from myocardial-infarction. Furthermore, the continuous (long-term) monitoring of the fetus during labor may save the fetus from distress[1]. We will discuss in section 1.3 the full implications of HRV recording and analysis.

1.2 Background Information

1.2.1 Anatomy and Function of the Heart

The human heart is a mechanical as well as an electrical system. Mechanically, the heart is a four-chambered pump for the circulatory system. The ventricles are the main pumping chambers while the atria are chambers which aid in the pumping. During a typical heart cycle, the atria contract pushing the blood into the ventricles. Next, the ventricles contract pushing the blood into the arteries, this is also called systole. Then, the atria relax causing the blood to flow in from the veins. Finally, the ventricles relax causing the blood to fill the ventricles; this is also known as diastole. The well-coordinated contraction of the ventricles and atria are the result of electrical actions taking place within the heart. Electrically, an action potential is generated at the sinoatrial (SA) node (Figure 1.1)[1]. Then, the action potential spreads over the atrial muscle causing the atria to contract. Next, the action potential passes through the atrioventricular (AV) nodes causing a 0.1s delay. The action potential then spreads over the ventricles causing the ventricles to contract. Finally, the atria relax and then the ventricles relax.

The human heart beats by itself because the process described above will repeat itself automatically. Since the heart produces bioelectrical signals, the electrical activity of the heart can be picked up, amplified, and recorded [2]. The best method has been through noninvasive means such as making electrical measurements of the heart. A voltmeter measures the voltage across the heart such as using a lead I configuration (Figure 1.2) [1].

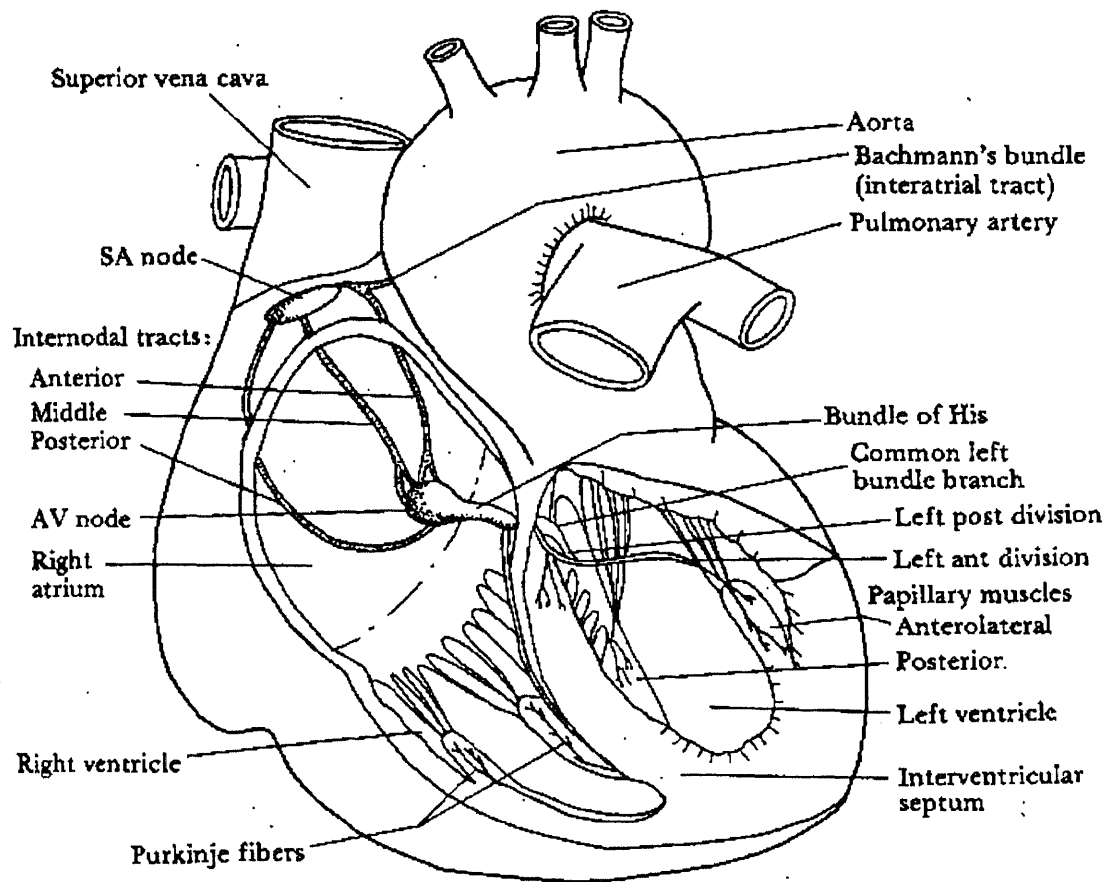

Figure 1.1 The conduction system of the heart[1].

A standard diagnostic ECG recording uses the 12 standard leads, which will be described in section 1.2.2. From the ECG measurement we know that every heart beat has a P, QRS, and T waveform, also called the deflection waves. First, we see the P wave with an amplitude of 0.25mV corresponding to the atrial contraction and depolarization (Figure 1.3) [1].

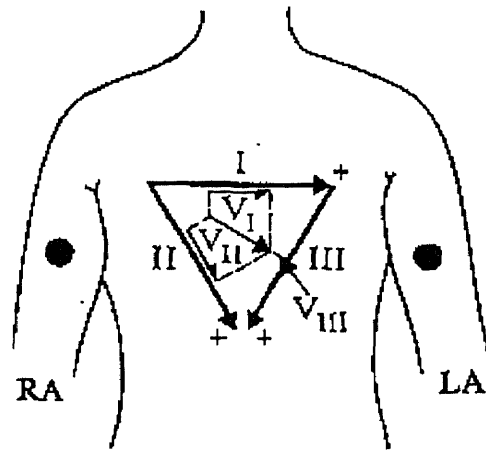

Figure 1.2 Standard notation for leads I, II & III [1].

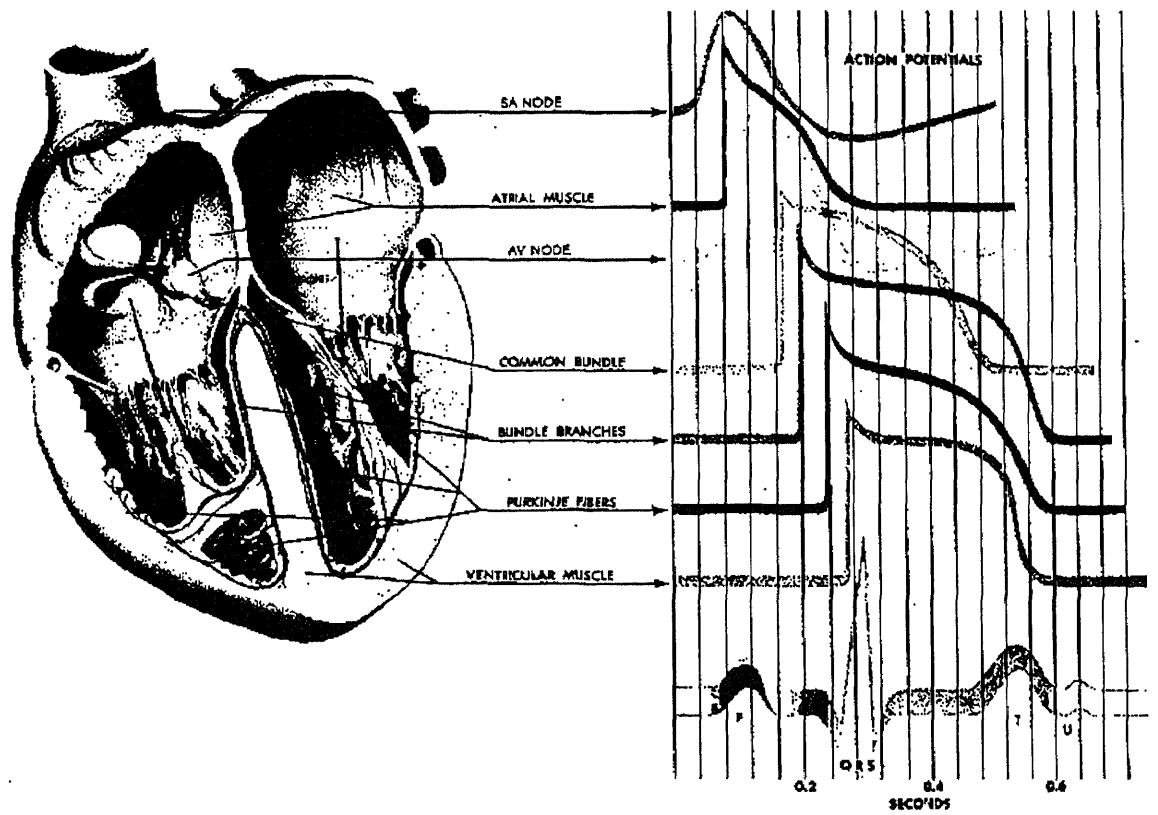

Figure 1.3 The electrical active regions of the heart [1].

The P wave lasts for about 0.08s and about 0.1s after the P wave had begun, the atria contracts. Next, we see the QRS complex, which corresponds to the ventricular contraction and depolarization with the R wave having an amplitude of 1-1.5mV. The average time for the QRS complex is about 0.08s. Its distinct shape reflects the different size of the ventricle and the time required for each ventricle to depolarize. Finally, we see the T wave with an amplitude of 0.1-0.5mV corresponding to ventricular relaxation and repolarization. This wave typically lasts for 0.16s and its shape reflects that atrial repolarization was over shadowed by ventricular excitation. From the measurement, we can see that the P-R interval lasts for 0.16s corresponding to the beginning of atrial excitation to the beginning of ventricular excitation (Figure 1.3)[1]. This interval also includes the atrial contraction as well as the depolarized wave passing through the AV node. The QT interval lasts for 0.36s corresponding to the beginning of ventricular depolarization through ventricular repolarization[2]. The P-P interval is an indicator of time per beat, 1/HR. For example, a person's heart beating 60bpm will have P-P interval of 1s. Actually, we know from the ECG measurement that the average heart rate is 70 beats/min. For a healthy heart, the patterns in the ECG measurement should be consistent. If the patterns within the waves such as the size, timing and duration are changed, then there may be a region of myocardial infarct or some problems within the conduction system.

1.2.2 ECG: Making the ECG Measurement

In this section, we will discuss the mechanism of making the ECG recording. First, the beating heart gives off electrical signals, which can be used to know more about the functions of the heart. Basically, the ECG is a measurement of the electrical events within the heart. Second, the electric potentials produced by the heart can be seen throughout the whole body and on the skin. We can measure the differences in the potential by placing electrodes on the skin (Figure 1.4)[1].

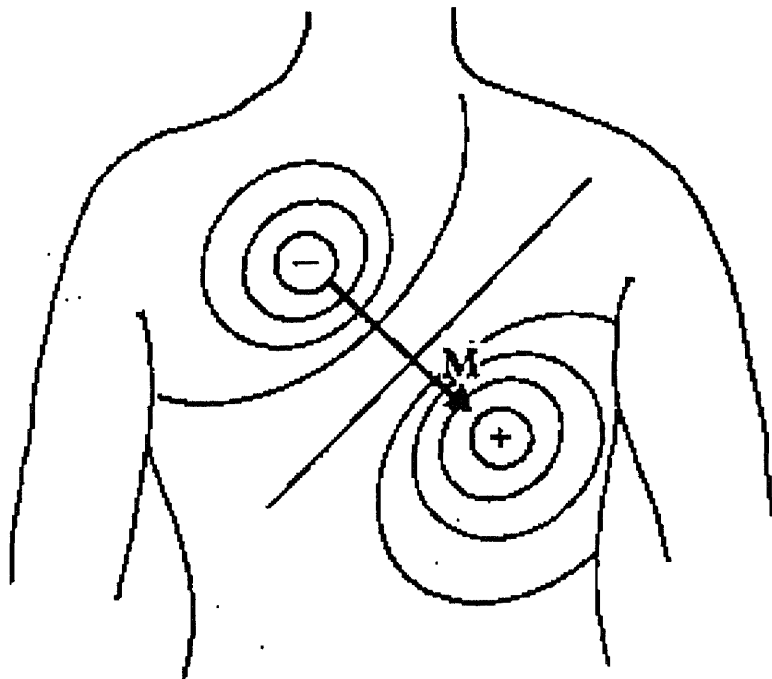

Figure 1.4 Dipole moment of the heart with the dipole moment vector M [1].

Next, since the voltages are different with respect to where the electrodes are placed from the heart, we need to have standard positions.

In clinical application of ECG, the 12 lead system has been used as the standard

[1]. In the 12 standard leads, there are 6 leads in the frontal plane and 6 leads in the transverse plane. The frontal plane is the plane of the body that is parallel to the ground when lying on the back. First, in Figure 1.5, we see 3 leads of the frontal plane, leads I, II and III, forming what is called the Einthoven's triangle. Using Kirchoff's voltage law, we can express the relationship as a vector addition: $I + II + III = 0$. Second, in Figure 1.6, we see how the other three frontal leads are formed, augmented leads aVL, aVR and aVF.

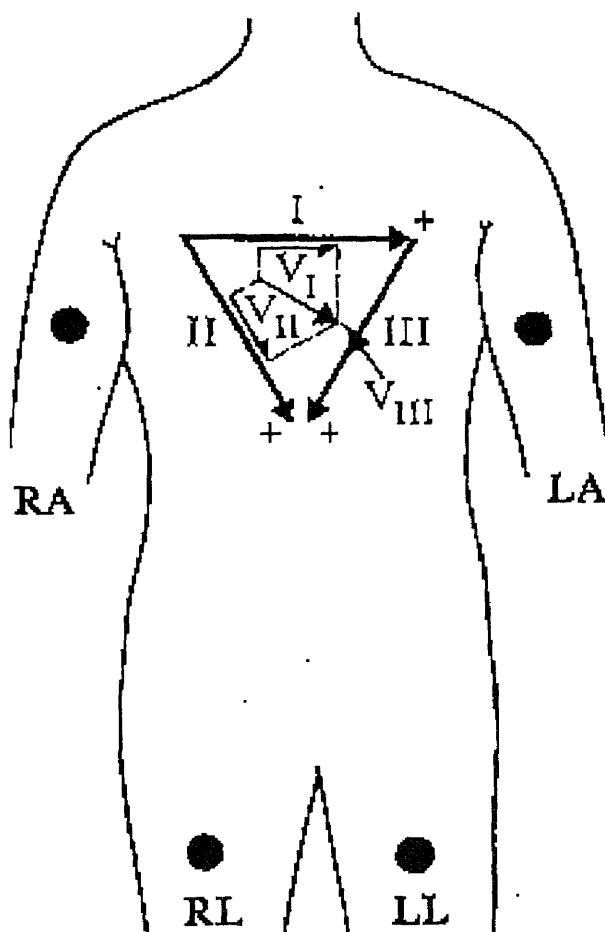

Figure 1.5 Frontal plane: standard leads I, II & III [1].

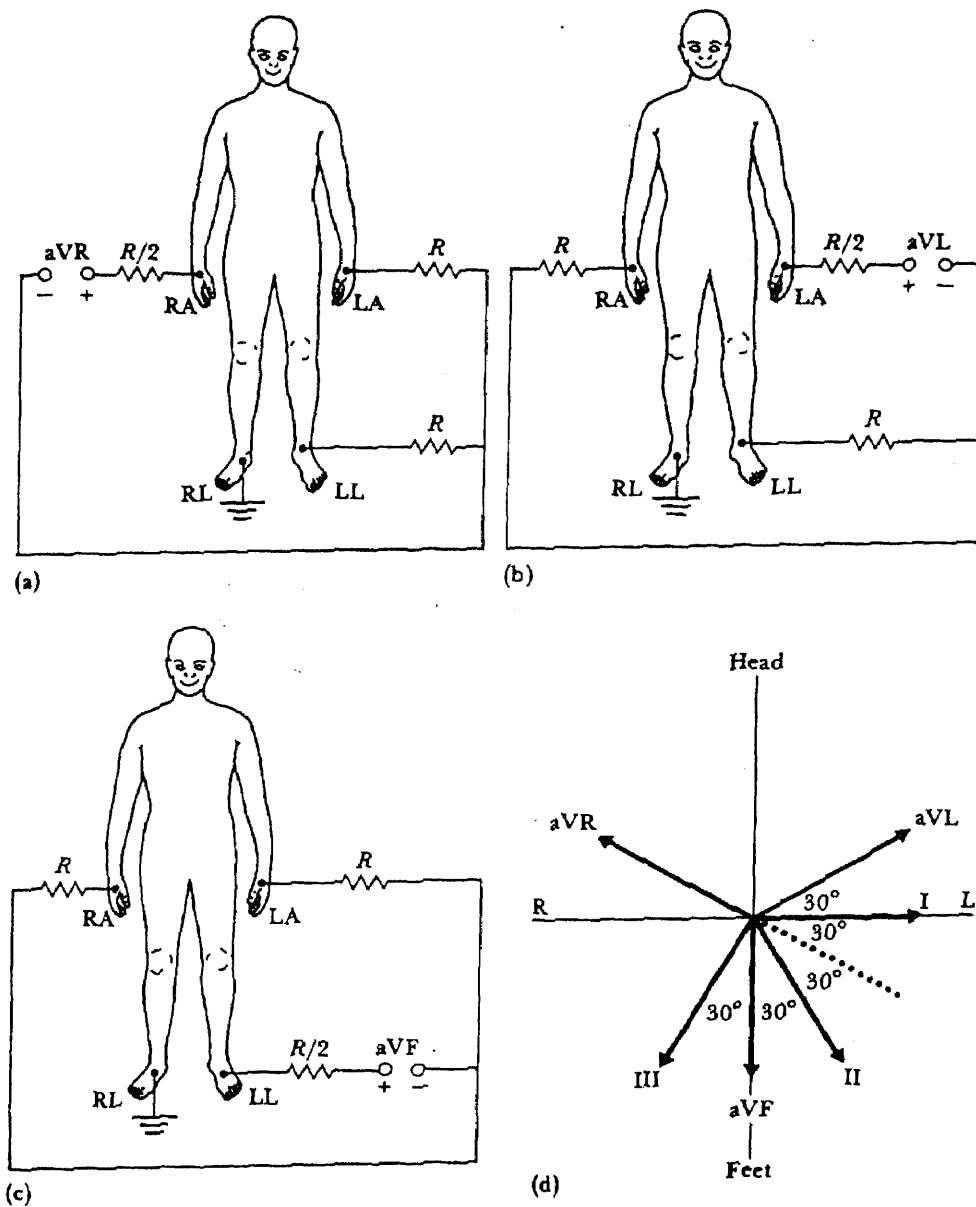

Figure 1.6 Frontal plane: connections for the 3 augmented leads [1].

Next, in order to get the ECG on the *transverse plane* (the plane of the body that is parallel to the ground when standing up), electrodes are placed on the chest wall. In

Figure 1.7, we see that from these electrodes, the other 6 transverse leads are obtained, leads V1, V2, V3, V4, V5 and V6.

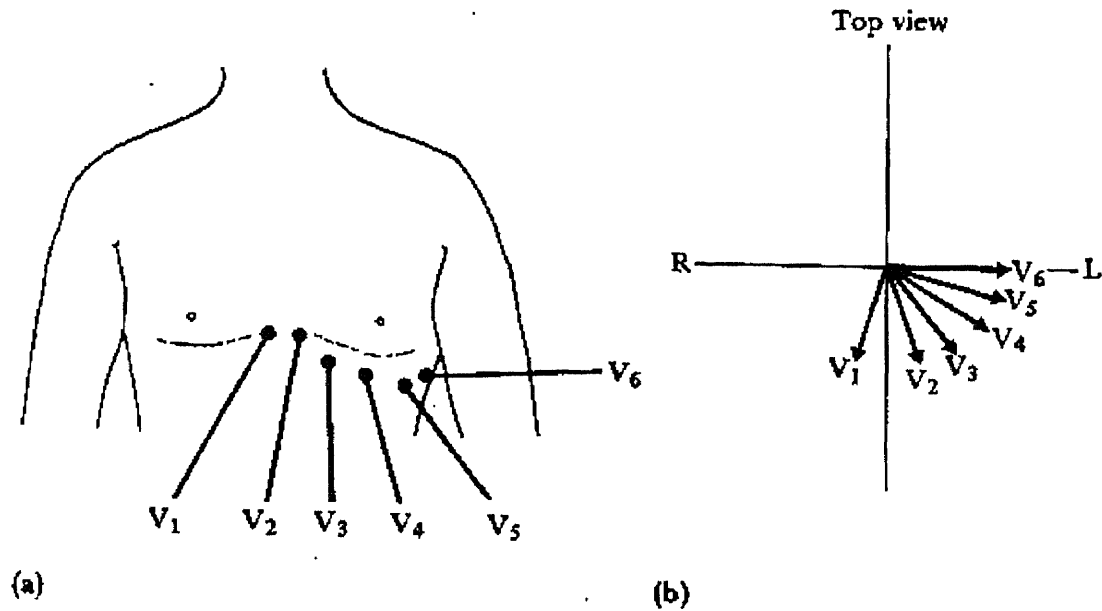
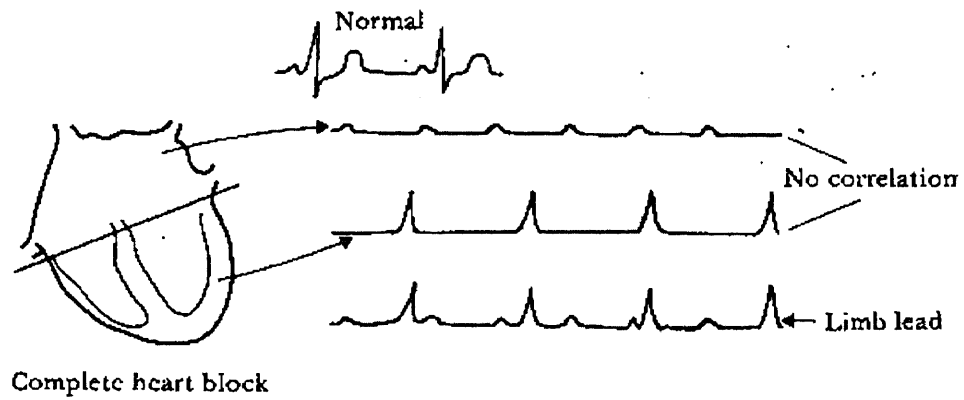
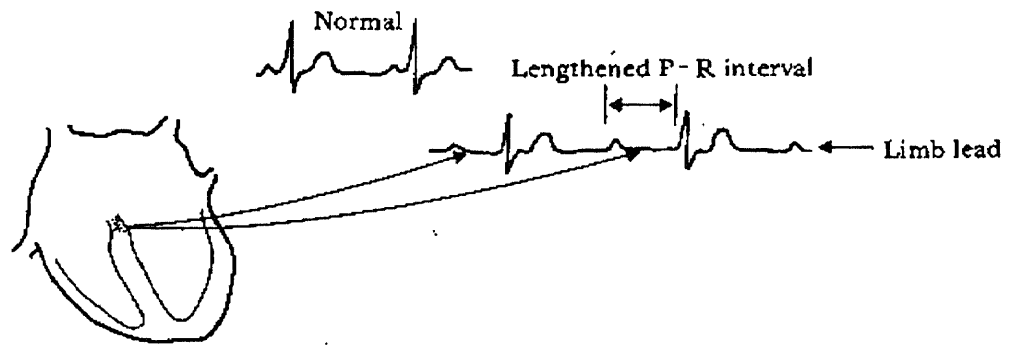

Figure 1.7 Transverse plane: the 6 precordial leads and their electrode placements[1].

With the usage of 12 standard leads, the ECG has been widely used as a diagnostic tool. Cardiologists now have an ECG standard they can agree upon to determine the cause of a cardiac problem. For example, an inverted or lost P wave can mean that the AV node has been acting as the pacemaker. Furthermore, heart conditions such as atrialventricular (AV) block (Figure 1.8a&b)[1], premature ventricular contraction (PVC) (Figure 1.9)[1], paroxysmal tachycardia and atrial flutter(Figure 1.10a&b)[1], and atrial and ventricular fibrillation(Figure 1.11a&b)[1] can be easily detected.



(a)



(b)

Figure 1.8 Atrioventricular (AV) block[1].

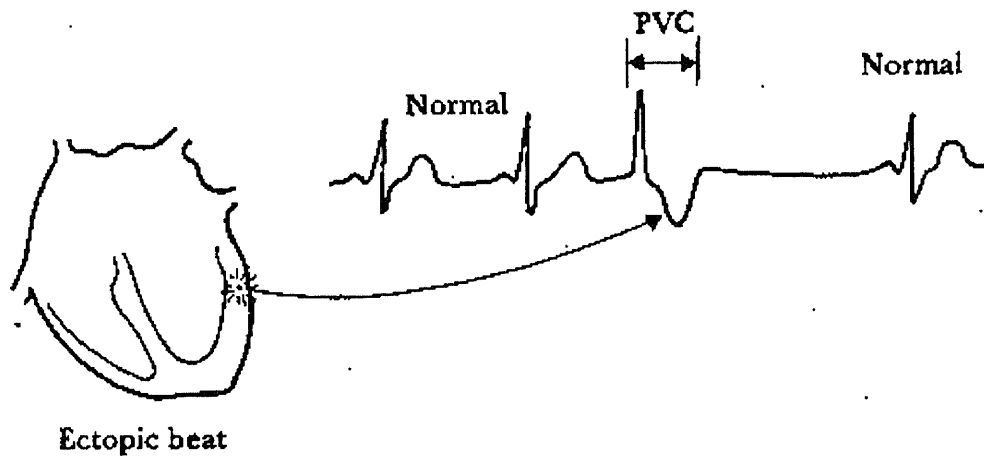

Figure 1.9 Extrasystole also known as premature ventricular contraction(PVC) [1].

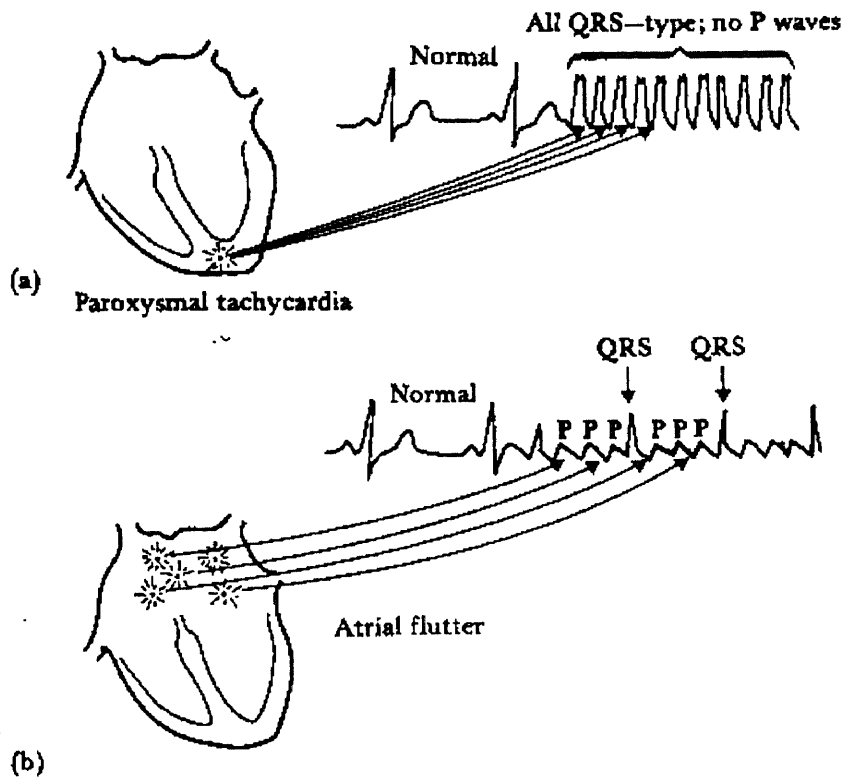

Figure 1.10 Paroxysmal tachycardia and atrial flutter: rapid beating rates

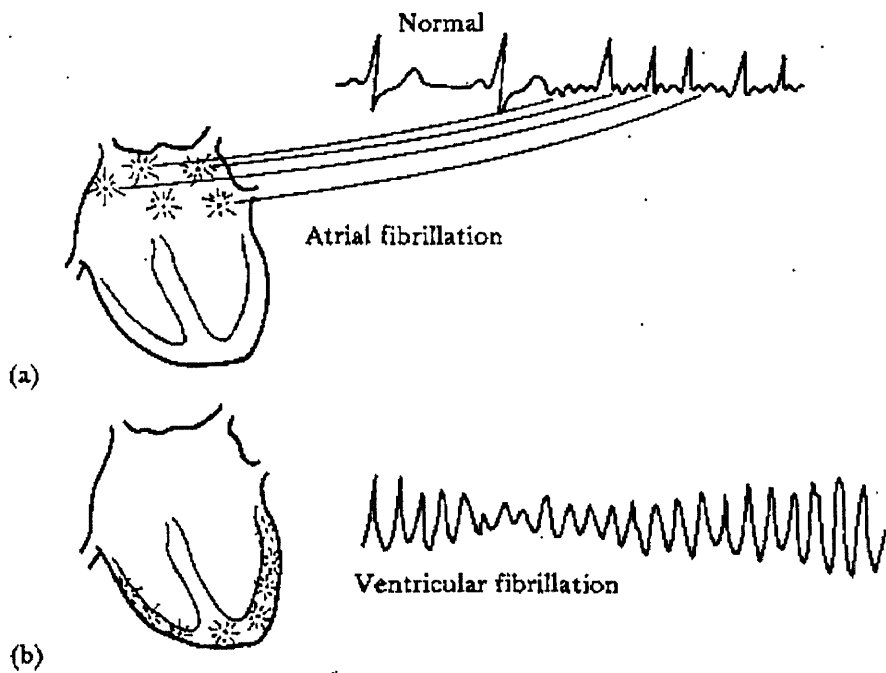

Figure 1.11 Atrial fibrillation and ventricular fibrillation: uncoordinated beating[1]

1.3 Literature Review

1.3.1 HRV

In this section we will discuss why heart rate variability is such an important measurement of the activities of the autonomic nervous system (sympathetic and parasympathetic nervous systems). We begin the discussion by explaining the significance of heart rate and HRV in general terms. We know that when a person increases physical activity, the heart rate also increases. Similarly, when the body is at rest, the heart beats are regular, but there is still a significant variation. Basically, the study of HRV is concerned with the amount of variation and the pattern of variation in the heart rate. This is the reason we emphasized the importance of ECG because we will derive the heart rate information from the ECG.

Cardiovascular variables such as the heart rate, arterial blood pressure, stroke volume and the shape of the ECG wave complexes all fluctuate on a beat-to-beat basis. In the past, these fluctuations have been ignored or averaged out as noise. The variability in cardiovascular signals reflects perturbations to the cardiovascular function and the dynamic response of the cardiovascular regulatory system[3]. Over the last thirty years, HRV has been gaining attention as a prognostic indicator of risk factors associated with number of chronic diseases, behavioral disorders, mortality, and even aging[4]. It has been found that greater variability is better or healthier(Figure 1.12). In contrast, a lack of variability is a sign of disease (Figure 1.13).

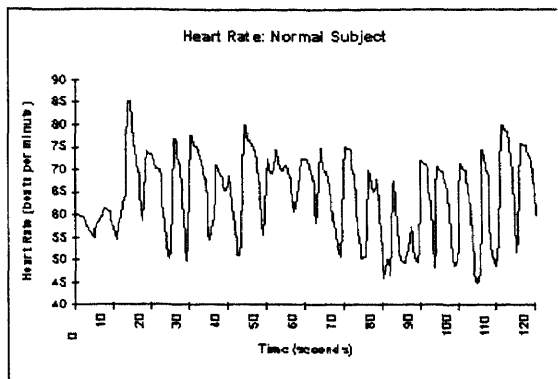

Figure 1.12 HR Normal Subject

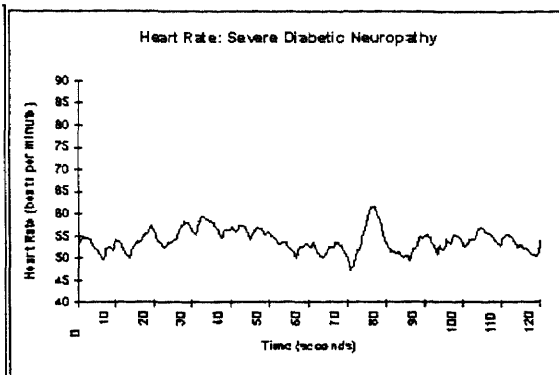

Figure 1.13 HR Severe Diabetic Neuropathy

From HRV research, it has been reported that when a person is under stress (Figure 1.15), there is a decrease in the power in the HF (0.15-0.4Hz) region of the HRV power spectrum from normal (Figure 1.14). This decrease in the HF region indicates a decrease in the parasympathetic activity (rest and relaxation). Similarly, it was found that the power in the LF (0.05-0.15Hz) region reflects the activities of both the sympathetic and the parasympathetic nervous system[4].

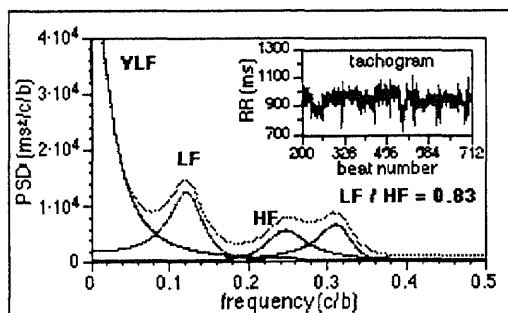

Figure 1.14 Subject normal/healthy.

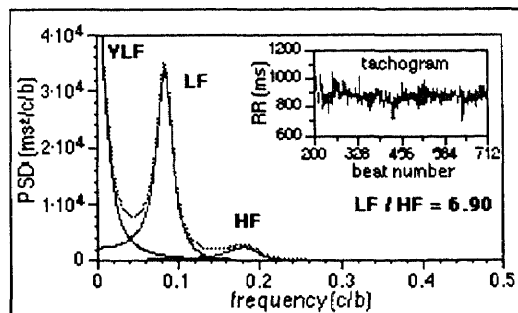

Figure 1.15 Subject under stress.

Risks of many chronic diseases can be determined by measuring the power in the low frequency and high frequency regions of the power spectrum. As mentioned earlier,

these regions correspond to the activities of the sympathetic and parasympathetic nervous systems. In the case of sudden infant death syndrome(SIDS), it was found that decrement in natural log-transformed low-frequency power was associated with a decrease of 70% in the hazard for all-cause mortality[4]. In the case of all-cause(cancer, cardiovascular disease, etc.) mortality in the elderly cohort, increased sympathetic tone or decreased in parasympathetic tone will predispose a patient to ventricular fibrillation, and reduced HRV associated with increased mortality[4]. Furthermore, in the case of drug addiction, it has been proposed that strong sympathetic reactivity and a fast return to relaxed baseline is a sign of physiological toughness, associated with advanced mental and physical health[4].

The Polar Vantage NV watch was also used to perform short term HRV studies. In Table 1.1(see complete list in Appendix A), the case of the essential hypertension:day(at rest), the low frequency power in the hypertensive subjects was significantly higher than the borderline hypertensive subjects, while the high frequency component was significantly less than for normal subjects[6]. Next, in the case of SIDS, an increase in the low frequency(LF) power is an indication of higher risk. Moreover, in the case of diabetic neuropathy:tilt, when tilting or standing, the increase in LF and decrease in high frequency(HF) components were greatly diminished[6]. Finally, smoking is followed by an increased LF component with a decreased in HF component. The LF/HF ratio is high, 1.5, during rest which corresponds to greater sympathetic activity.

Table 1.1 Polar HRV Results

Diseases			
Power spectral density	LF	HF	LF/HF
essential hypertension: rest	>	=	>
essential hypertension: tilt	>>	=	>>
essential hypertension: day (at rest)	>>	<	>
essential hypertension: night (at rest)	>	=	>
diabetic neuropathy: mild	<	<	=
diabetic neuropathy: severe	<<	<<	=
diabetic neuropathy: tilt	(>)	<	>
smoking: acute	>	<	>
smoking: chronic	=	<<	>
SIDS risk	>	<	>
tetraplegie	∅	=	
stress	>	<	>

> increase, < decrease, = no changes, multiple arrow = intensity, () slightly, ∅ not existent

In R.P. Sloan's[7] study with ambulatory subjects, the results revealed significant effects of individual differences, stress, and physical position on RR interval, with increases in stress associated with decreases in RR interval as expected. HF power was significantly lower and LF/HF ratio significantly higher in the standing compared with the sitting position. Psychological stress was significantly associated with an increased in the LF/HF ratio, suggesting increases in the relative predominance of sympathetic nervous system activity during stressful periods of the day. L. Bernardi[8] proposed that diabetic subjects have a high incidence of cardiovascular accidents, with an altered circadian distribution and the abnormalities in the circadian rhythm of autonomic tone may be responsible for this altered temporal onset of cardiovascular disease. He found that diabetic subjects with or without signs of autonomic neuropathy have decreased vagal activity (a relatively higher sympathetic activity) during the night hours and at the same time of the day, during which a higher frequency of cardiovascular accidents has

been reported. This study will give us insight into increase cardiac risk of diabetic patients if autonomic neuropathy is present. H.V. Huikuri[9] investigated whether there was a temporal relation between changes in HRV and the onset of spontaneous episodes of ventricular tachycardia(VT) in patients at high risk of life-threatening arrhythmias. He commented that low HRV is associated with an increased risk of arrhythmic death and VT. He found that spontaneous episodes of VT are preceded by changes in HRV in the frequency domain. Divergent dynamics of HRV before onset of nonsustained and sustained VT episodes may reflect differences in factors that can facilitate the perpetuation of these arrhythmias. G.E. Billman[10] investigated the effects of physiologic perturbations such as exercise have on the HRV with animals known to be susceptible ventricular fibrillation. He commented that periodic fluctuations in the R-R interval have been used as noninvasive measures of cardiac autonomic tone, and a reduced HRV has been shown to correlate with an increased mortality in patients recovering from myocardial infarction. His results shown that exercise elicited a greater reduction in cardiac vagal tone. H.V. Huikuri[11] investigated and compared the circadian rhythm of cardiac neural regulation and autonomic uncomplicated coronary artery disease (CAD) and age-matched subjects with no evidence of heart disease. He found the healthy subjects had a significant circadian rhythm of normalized units of HF power of HRV with higher values during sleep. Normalized units of LF power and the LF/HF ration also showed significant circadian rhythm in healthy subjects, with higher values during the daytime. Their findings suggested the circadian rhythm of cardiac neural regulation is altered in the patients with uncomplicated CAD. Reduced autonomic responses to sleep-wake rhythm suggest that the modulation of cardiac autonomic

function by stimuli from the central nervous system is impaired in CAD. S.S. Hull[12] did paired studies with dogs to examine HRV before and after myocardial infarction. His results showed that 30 days after infarction, the mean RR interval, the standard of deviation, and the coefficient of variance were significantly decreased. His study suggested the analysis of 30 min of beat to beat heart period at rest 30 days after myocardial infarction are highly predictive for increased risk of sudden death. F. Lombardi [13] investigated the circadian variations of spectral indices of HRV with patients after myocardial infarction (MI) and control subjects. The results showed that the control subjects were characterized by predominance of LF (~0.1Hz) component during the day and of HF (0.25Hz) component during the night, which reflected the expected 24h pattern of variation of sympatho-vagal balance. The MI patients were characterized with a 24h elevation of the LF and small HF component during the night. The two groups were further differentiated by the LF/HF ratio. By spectral analysis of HRV, the results suggested that in patients after MI there was an alteration of neural control mechanisms as indicated by the presence of signs of sympathetic activation and by the attenuation of the nocturnal increase in vagal tone.

1.3.2 1/f

Modern signal processing techniques provide means of analyzing beat to beat fluctuations in cardiovascular signals, thus permitting a quantitative, noninvasive method of assessing the activities of the autonomic nervous system. The use of spectral analysis techniques to quantify short-term heart rate fluctuations on the order of seconds to minutes has helped to define the autonomic contributions to beat-to-beat control of the

heart rate. J.P. Saul et. al.[15] used similar techniques to quantify the entire spectrum (0.00003-1.0Hz) of HRV using the standard Holter monitor for 24h ECG. They found that the human HRV contained 1/f behavior in the frequency range from 0.00003 to 0.1Hz. By plotting the log of the power spectrum versus the log of the frequency of the entire 24h recording, the power spectrum was inversely proportional to frequency, 1/f (Figure 1.16).

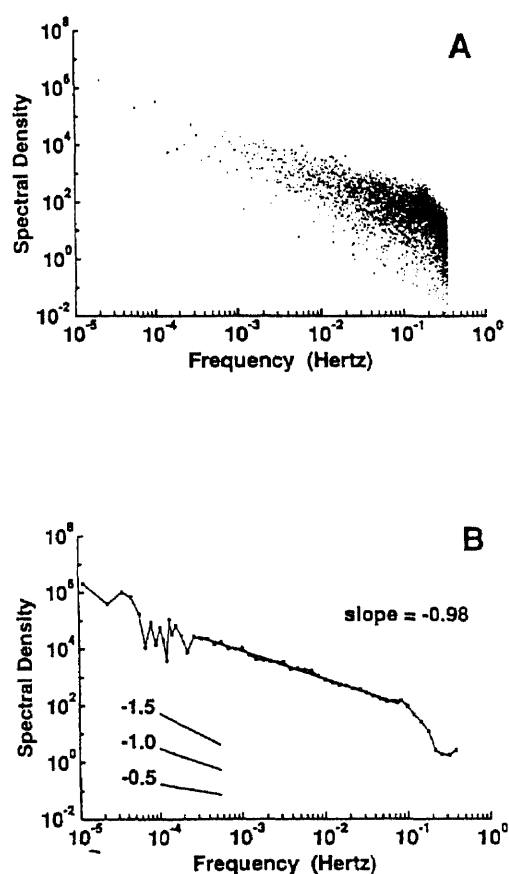

Figure 1.16 1/f in the range 0.00003 to 0.1Hz.

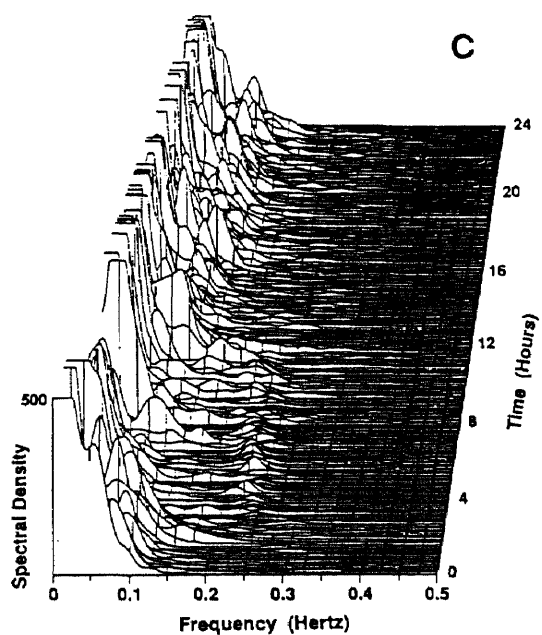

Figure 4. The point spectrum (a) and smoothed spectrum (b) between 0 and 0.4 Hz for the same 24.27 hour time series are shown on a log frequency vs. log density ((beats/min)²/Hz) display. The slope in (b) was calculated from the regression line shown in the figure. Consecutive 5 minute spectra of the same data are displayed in (c) on linear axes. Between hours 4 and 11 the subject was sleeping and a relatively discrete respiratory peak appears near 0.2 Hz; however, the peaks otherwise constantly drift in frequency and amplitude. Lower frequencies clearly dominate throughout the record.

In the literature, considerable attention has been given to the understanding and application of 1/f fluctuations of the HRV[13,14,15,16]. It has been hypothesized that

the circadian rhythm generator is responsible for the $1/f$ fluctuation [13]. Yamamoto and Nakamura[17] cited that long-term HRV data (more than 2h) will have the characteristic of the $1/f$ spectrum. Kobayashi and Musha [16] reported that the $1/f$ spectrum appeared in the frequency range below 0.02Hz during awake bedrest for 10h. Saul et. al.[15] and Ichimaru et. al.[13] both observed the $1/f$ relationship in the 0.00003Hz to 0.1Hz frequency range (24h recording). Yamamoto and Hughson[18] found that there was a clear $1/f$ relationship above the frequency of 0.01Hz .

In Ichimaru's[13] study of comatose patients, they also found that the slope of the power spectrum was -1.17(the frequency band less than 0.01Hz) for the locked-in syndrome patient (Figure 1.17) and slope of -1.2

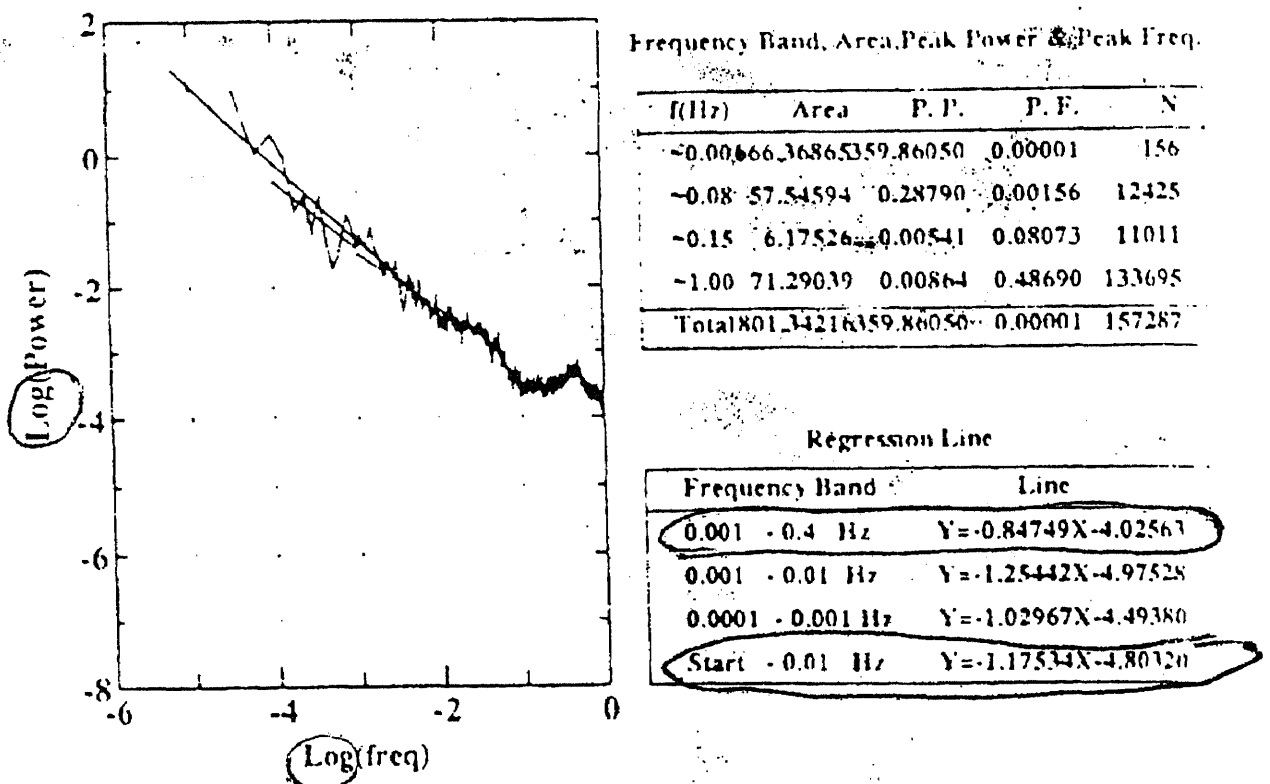

Figure 1.17 Locked-in syndrome patient[13]

for the Creutzfeldt-Jakob disease(CJD) patient. For the CJD patient, there was a plateau in the 0.001 and 0.0005Hz range caused by the rhythmic component during the night (Figure 1.18)[13].

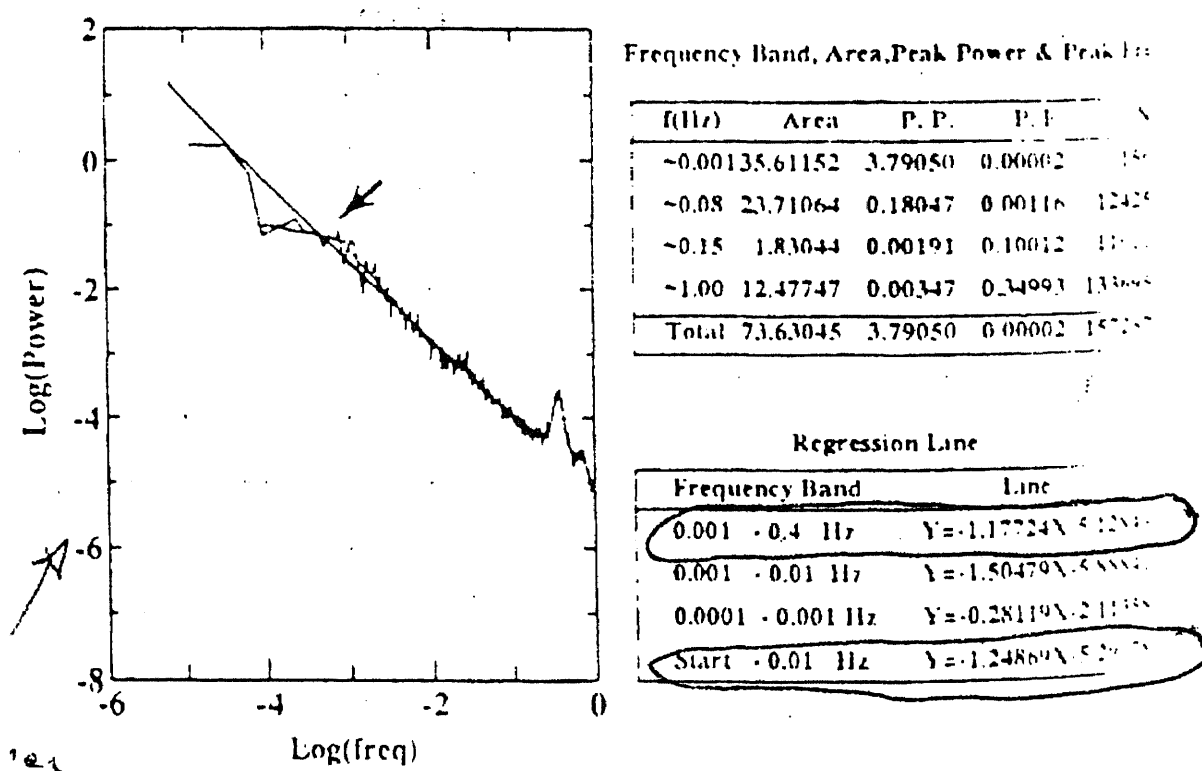

Figure 1.18 Creutzfeldt-Jakob disease (CJD) patient

In the brain dead patient, there was a peak at 0.2Hz corresponding to the 12bpm breathing rate and the slope was -1.91 below the 0.01Hz range. The brain dead patient also had a plateau in the 0.001Hz range caused by the cyclic changes in the heart rate (Figure 1.19)[13]. Ichimaru et. al.[13] found that the slope of the 1/f scale became steeper as conscious level decreased. The slope of the log-log power spectrum is dependent on

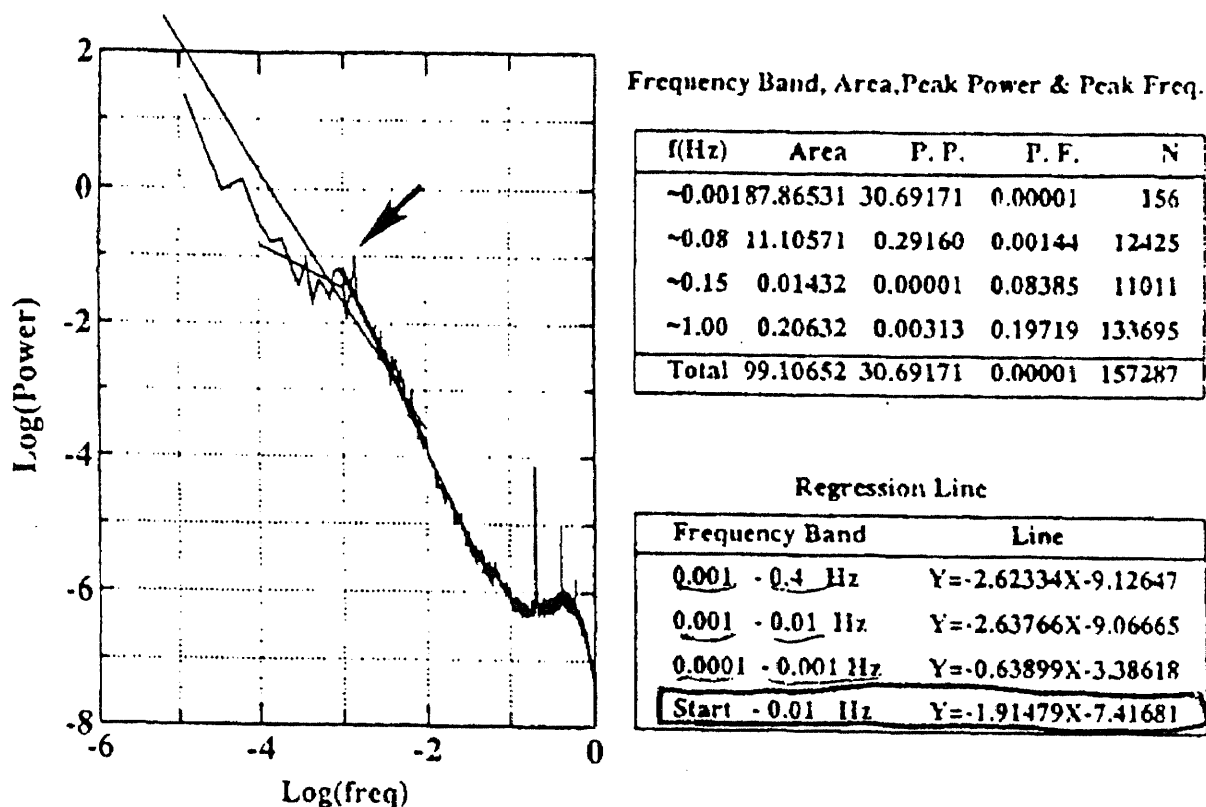

Figure 1.19 Brain dead patient

the high frequency and the very low frequency components. Additionally, it was found that long-term HRV might be modified by the central nervous system and can be used in assessing a patient with coma.

1.3.3 Circadian Rhythm

Some researchers suspect that organisms possess internal times called the circadian rhythm. The circadian rhythm is mainly control by the central rhythm generator in the brain. The circadian rhythm activities synchronized with the day-night cycle under constant conditions. If there are no external rhythmic stimuli, the free-running behavior cycle is usually +1h or -1h different than 24 hours and differs slightly from one individual to the next. It is likely that some of the mechanisms controlling the circadian

rhythm are influenced by the daily activities and by the outer noise[13]. Y. Ichimaru et al.[13] did a study on coma patients because they suspect then the heart rate is not influenced by outer noise, and from the signal processing point of view, the signals are linked directly to the activities of the central rhythm generator. In their study, the circadian rhythm of the low frequency region and the high frequency region were obtained from the fast Fourier Transform(FFT) analyses of the heart rate for every 10 minutes. There was a circadian rhythm in the heart rate in both the LF area and the HF area. From the power spectrum, the circadian rhythm at night showed an increase in HF and was decreasing in the LF. By contrast, the normal circadian rhythm in the morning was increasing in the LF and decreasing in the HF (Figure 1.20)[13].

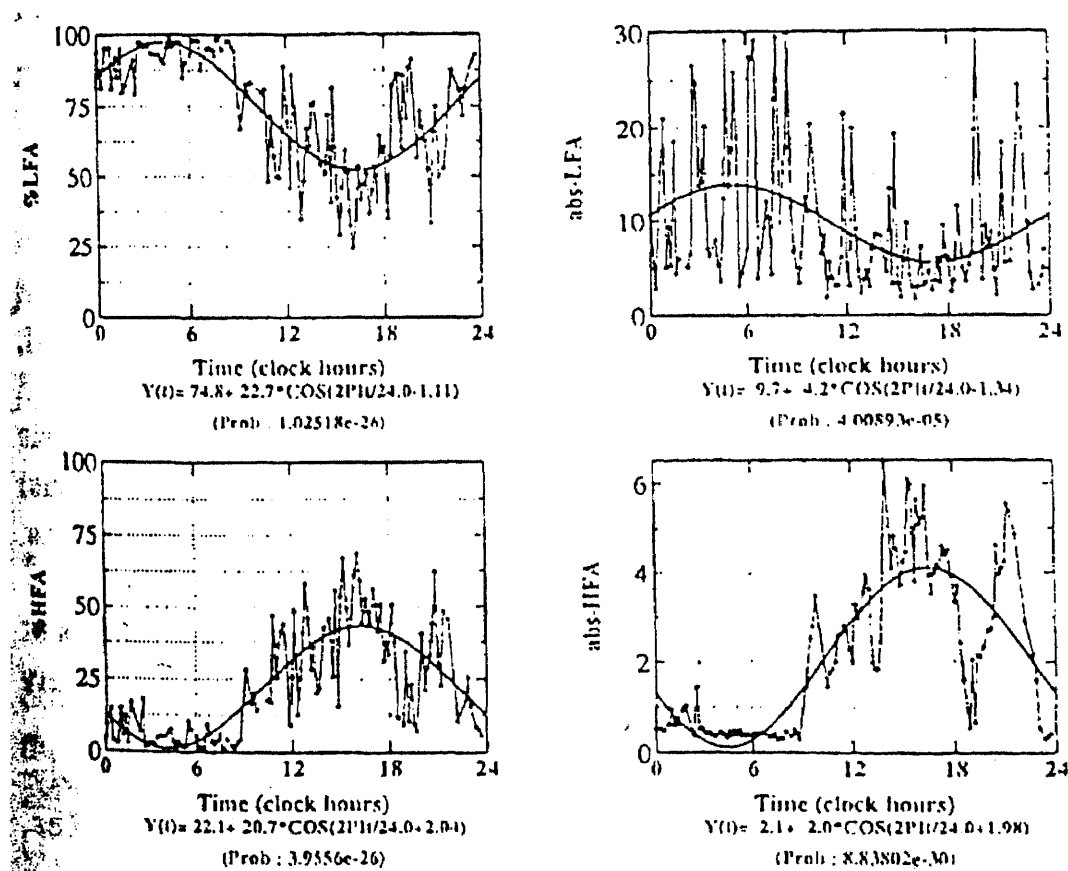

Figure 1.20 LF & HF vs. time plots

As a result, Ichimaru et. al.[13] found that the circadian changes were initially there from the beginning of hospitalization for brain dead patients. The technique is very useful, as with the 1/f, in long-term HRV application of understanding the activities of the central nervous system and in assessing coma patients. Others also did work with 24h Holter monitoring. Burbuera and Gandia[19] did 5min intervals of the 24h data and found that the greatest difference between day and night was LF/HF ratios. Venkatesh and Fallen[20] noted that the HF peak power was during the hours of 6-10am. They also added that when a normal person gets up the LF power is usually increased. Chakko and Mulingtapang[21] did a 10min intervals of 24h data analysis. They found that in normal people, HF fluctuates. The LF power was found to be lower at night and increased during the morning hours in the control group. Panina and Khot[22] did a 4min interval of every hour for the 24 hour period, and didn't find any significant variation in the HRV in congestive heart failure(CHF) patients, but they found out that even with CHF, the circadian variation was preserved in mean heart rate. The mean heart rate was significantly reduced in the night time compared to the daytime.

1.3.4 Non-Linear Dynamics

HRV is characterized by a variety of linear, non-linear, periodic and non-periodic oscillations. Common non-invasive diagnostic methods like Holter monitoring or the analysis of high-resolution ECG and HRV are unable to accurately assess the individual risk for sudden cardiac death, since they only describe linear or strictly periodic behaviors. Using new methods of non-linear dynamics one can now calculate parameters which much better describe the dynamic behavior of complex systems. The application

of these new methods should therefore lead to an improved identification of high-risk patients. J.K. Kanter et. al.[23] investigated the short- and long-term variations in the non-linear dynamics of HRV, to determine the relationship between conventional time and frequency domain methods and the newer non-linear methods of characterizing HRV. Subjects were investigated by 3h ambulatory ECG recordings, and they found that there was a significant amount of non-linear dynamics existing in the HRV. Non-linear predictability is correlated with HRV measured as the standard deviation (a linear measure) of the R-R interval and the respiratory activity expressed as power of the high-frequency band. Figure 1.21 & Figure 1.22 from our data confirmed their findings where set 1 was sick and set 2 was healthier.

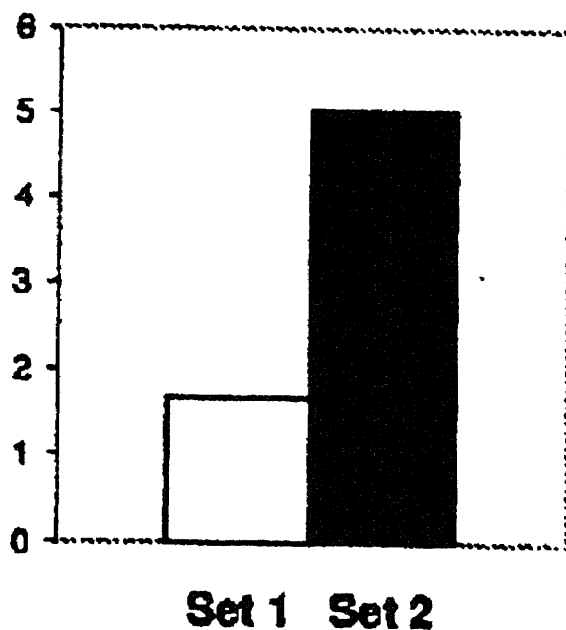

Figure 1.22 Standard deviation measure: higher standard deviation, healthier.

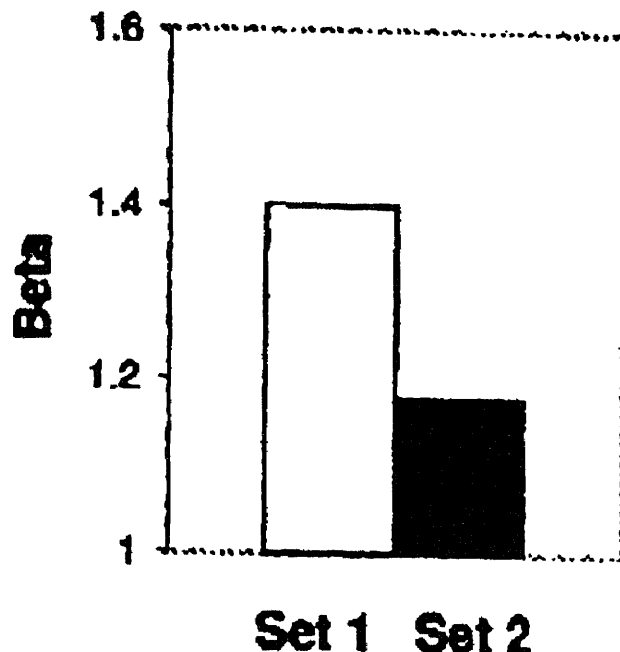

Figure 1.23 Beta measure: beta closer to 1.0, healthier.

Their findings suggest that HRV consists of intertwined periods with different non-linear dynamics. S. Guzzetti et. al.[24] investigated the role of neural mechanisms in determining non-linear and non-periodic components. Using heart transplanted patients and controls, they found the non-linear dynamic parameters were significantly lower in transplanted subjects than the control. These results indicate that non-linear dynamics are likely to be present in HRV control mechanism, giving rise to complex and qualitatively different behaviors. A. Voss et. al.[25] investigated new methods of non-linear dynamics(NLD) and compared these with traditional methods of HRV and high resolution ECG(HRECG) in order to improve the reliability of high risk classification. Using long-term ECG recordings of subjects that were high risk and low risk cardiac patients and healthy people. They found that non-linear dynamics analysis led to a distinction between healthy and high risk. The time domain and frequency analysis was successful in less than 90%. A combination of both analyses separated completely these

groups to 100%. Their findings suggest that methods of NLD describe complex rhythm fluctuations and separate structures of non-linear behavior in the heart rate time series more successfully than classical methods of time and frequency domains. This led to an improved discrimination between normal (healthy persons) and abnormal (high risk patients). Their methods of symbolic dynamics and renormalized entropy were useful measures for classifying the dynamics of HRV. T.H. Makikallio et. al.[26] investigated the possible abnormalities in the beat to beat complexity of heart rate dynamics in patients with a previous myocardial infarction. It has been proposed that regularity or loss of complexity of RR interval dynamics may be related to pathologic state. Their subjects consisted of postinfarction patients and healthy persons. Using approximate entropy and conventional time and frequency domain measures of RR interval, they found the postinfarction patients had lower standard deviation. Our data confirmed their findings as in Figure 1.21. Y. Yamamoto et. al.[18] investigated the effects of the vagal blocker atropine on the fractal nature of human HRV at rest. Their subjects consist of cardiac patients and healthy persons. Their result showed that atropine decreased the normally irregular fractal pattern of resting HRV. Subjects injected with atropine(cardiac patients and healthy persons) showed significantly less HRV and significantly greater beta compared to the control. Our data confirmed their findings as in Figure1.22. Yamamoto et. al.[17,18] also explained that the Hurst exponent, $0 < H < 1$, contained the information on the dynamics of a random time series. If $H = 1$, then it corresponded to a strong positive correlation. If $H = 0$, then there was a negative correlation. Fractal is defined as having self-similar property. It implies that the distribution remains unchanged even after we change the time scale to read it. These fractal fluctuations are

known to have $1/f^\beta$ type of spectra in the log frequency vs. log power. Dependent on Beta, the fluctuations are called pink noise (Beta = 1), Brownian motion (Beta = 2), and black noise (Beta = 3). Beta is linked to H by $H = (\text{Beta} - 1)/2$ therefore $\text{Beta} = 2H + 1$ for $1 < \text{Beta} < 3$ [17, 18].

CHAPTER 2

METHODS

2.1 Data Acquisition

Long-term heart rate measurement (HRM) was done using the Polar Advantage NV system (Figure 2.1)[27]. This system consisted of the Polar coded transmitter, the elastic strap, and the wrist receiver.

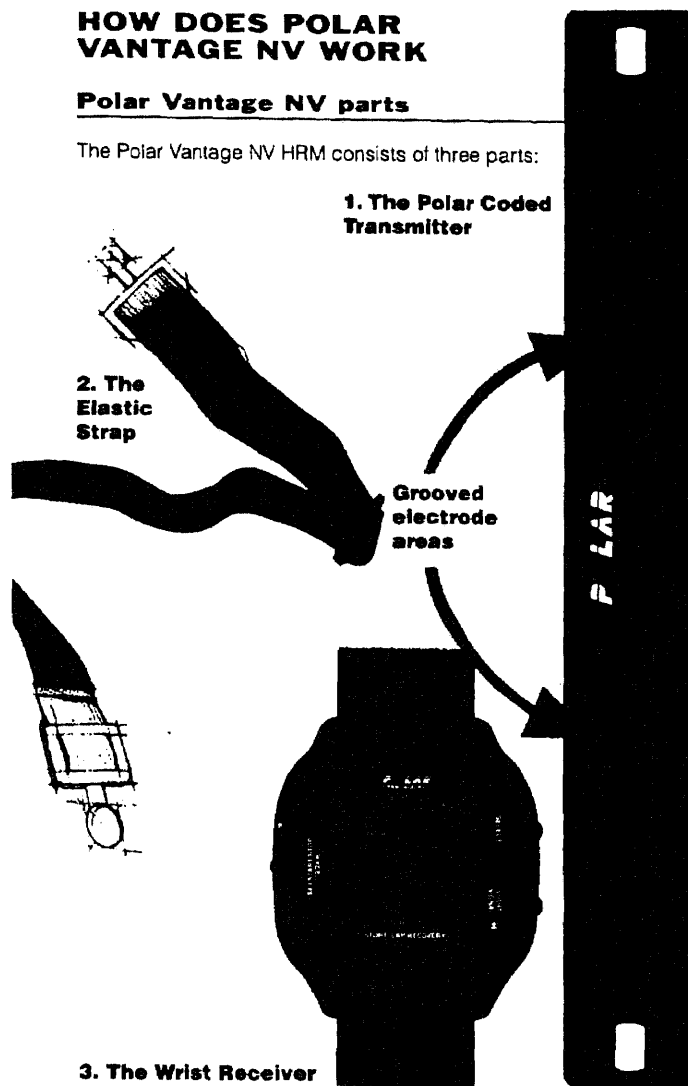

Figure 2.1 Polar Vantage NV parts

2.1.1 Watch Functions (Figure 2.2)

- watch with alarm clock, calendar and weekly indicator
- 12/24h display
- alternative displays in measurement mode(i.e. the HR recording)

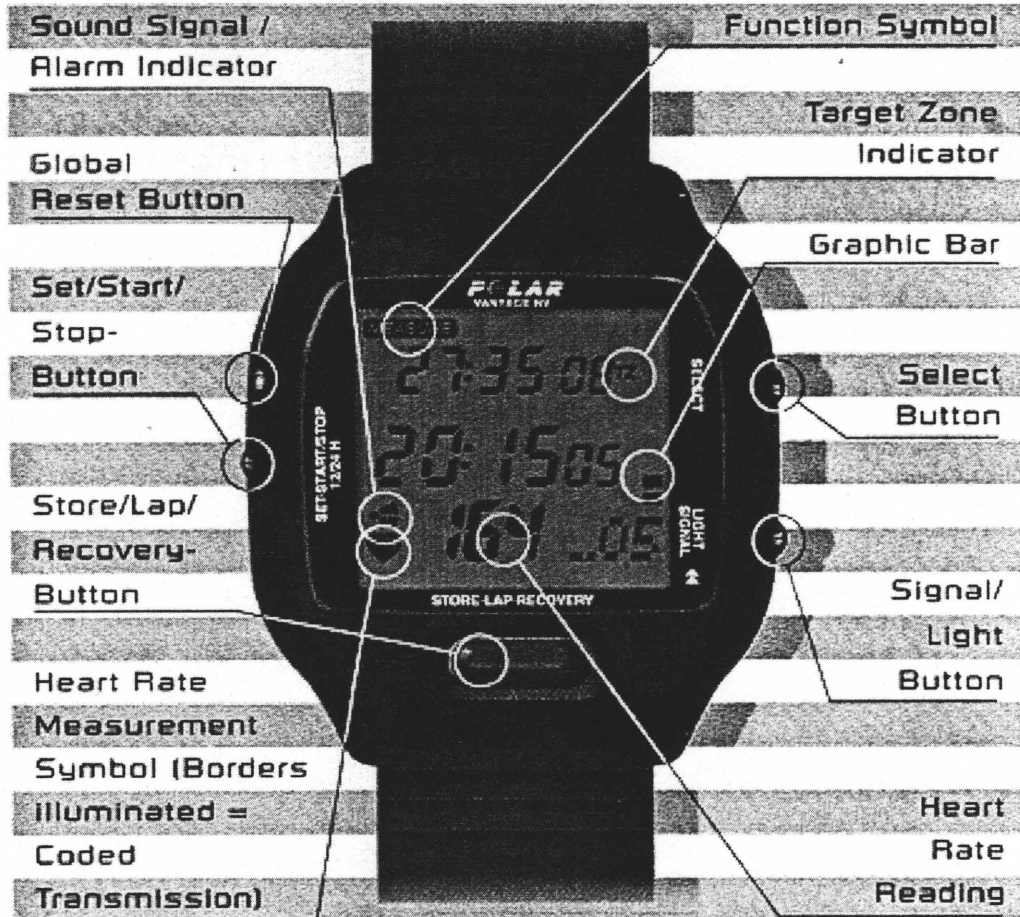

Figure 2.2 Watch functions

Figure 2.3 shows the Data Transfer Functions with the Interface. The electrical signals from the heart are picked up by the electrodes on the transmitter. The transmitter then sends the signals to the receiver and the receiver downloads the data into the computer through the interface.

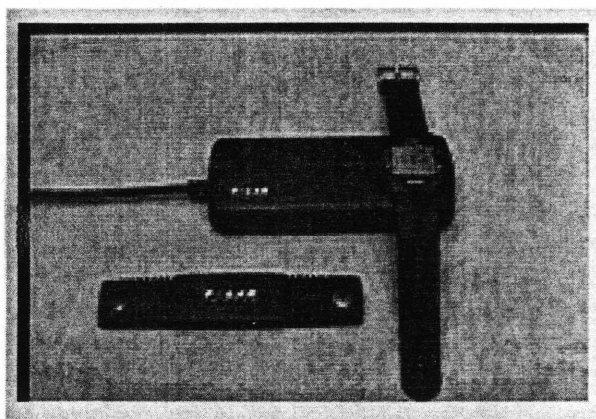

Figure 2.3 Watch-interface system

Figure 2.4 shows how to wear the Polar Vantage NV HRM .

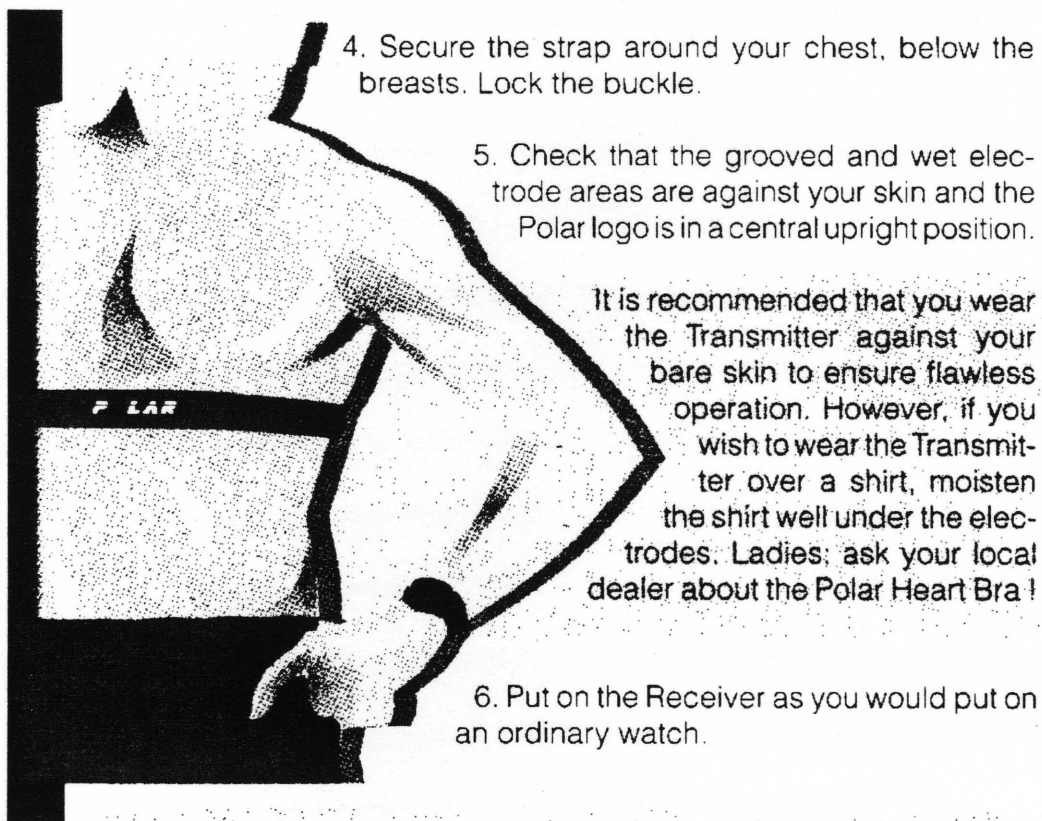

Figure 2.4 Wearing the heart rate monitor (HRM)

2.1.2 Changing the Recording Interval

1. Press SELECT (upper right button in Figure 2.2) to enter the FILE mode, where you can recall the results recorded during the exercise period.
 - FILE starts flashing.
 - LEFT and FILES start scanning on the display.
 - INT starts flashing on the display.
2. Press SIGNAL/LIGHT (lower right button in Figure 2.2) to change the recording interval.
 - INT and the symbol of the current selection for the recording is flashing on the lower right corner of the display.

Table 2.1 Recording interval alternatives

RECORDING INTERVAL	HR RECORDING	FULL MEMORY
RR	Every heart beat	4000 heart beats
5s	Every 5 seconds	11h 13min
15s	Every 15 seconds	33h 41min
60s	Every 60 seconds	124h 46min

The R-R-recording indicates the HRV and measures the time in milliseconds between two successive heart beats. R-R-recording is suitable for measuring HRV in non-exercise and at resting situations. It's recommended to use Contact Gel (ECG gel) to ensure good contact between skin and transmitter. It's suggested to minimized the use of lap times, timers and backlight functions to avoid disturbance during R-R-recording.

This function is vary important because in all three studies setting it to 5s interval allowed us to do longterm recording. It was especially important in Study 1 where we had to use the RR and 5s intervals. The detailed information about Heart Rate Monitoring Functions, Recording Functions, Data Transfer Functions, Setting the HR Limits 1&2, and starting the heart rate measurement are all listed in Appendix B.

2.1.3 Study Protocol

For statistical reasons, the standard for research is to have as large a population as possible. Due to the exploratory nature of this study, the study population was small. In Study 1(1/f) and Study 2(Circadian Rhythm), one normal subject, a 23 year old male, was used. In Study 1, for the RR recording, the subject was put in a quiet room. The electrodes on the transmitter were wet and put on the subject. He was then to recline on his back. The recording began and ended after 1 hour. Immediately after the RR recording the data was transferred to the computer. Then the subject was set up for the 5s recording. The subject put on the transmitter and receiver and the recording began. The subject was allowed to move and do daily activities outside the house. The activities were characterized as non-exercise or at resting situations. Recordings were made while the subject was lying on his back, sitting down reading, watching TV, walking, eating meals and during deep sleep. After 11 hours, the 5s recording ended. The 5s data was transferred to the computer and the subject was set up again for the RR recording. This procedure was repeated three times. As a result, three RR files and three 5s files were obtained for Study 1. In Study 2, the watch was set to record at 5s interval. The subject put on the receiver and the transmitter early in the morning (waking up from sleep). The recording began. The recording continued throughout the day while the subject performed non-exercise activities such as light walk, sitting down, standing up, lying down, sleeping, and reading. After 11 hours the recording ended. The data was transferred to the computer. At night, the subject put on the receiver and the transmitter. The recording began and the subject was at rest and asleep throughout the night recording. After 11 hours, the recording ended. The data was transferred to the computer

and the morning recording began. This morning and night recordings repeated three times. As a result, we obtained three 11h morning recordings and three 11h night recordings.

In Study 3 (Non-linear Dynamics), five subjects were used. The subjects included two cardiac patients, a 71 year old male (sk) and a 35 year old female, and three normal subjects, a 44 year old female (agd), a 62 year old male (id), and a 35 year old female (kp). The watch was set to record HR at 5s interval. The subjects put on the receiver and the transmitter and recording began while the subjects were performing activities that would be characterized as non-exercise or at resting situations. The recording ended 11 hours later. As a result, we obtained 17 recordings. The breakdown of the recording was mm (2), adg (3), id (1), kp (2), and sk (9). We also wanted to see trends over a period of several months. As a result, recordings for sk began 1/18/98 while he was sick to 6/20/98 when he was healthier.

For all the recordings, the upper limit on the watch was set to 160beats/min and the lower limit was set to 80beats/min (Figure 2.5).

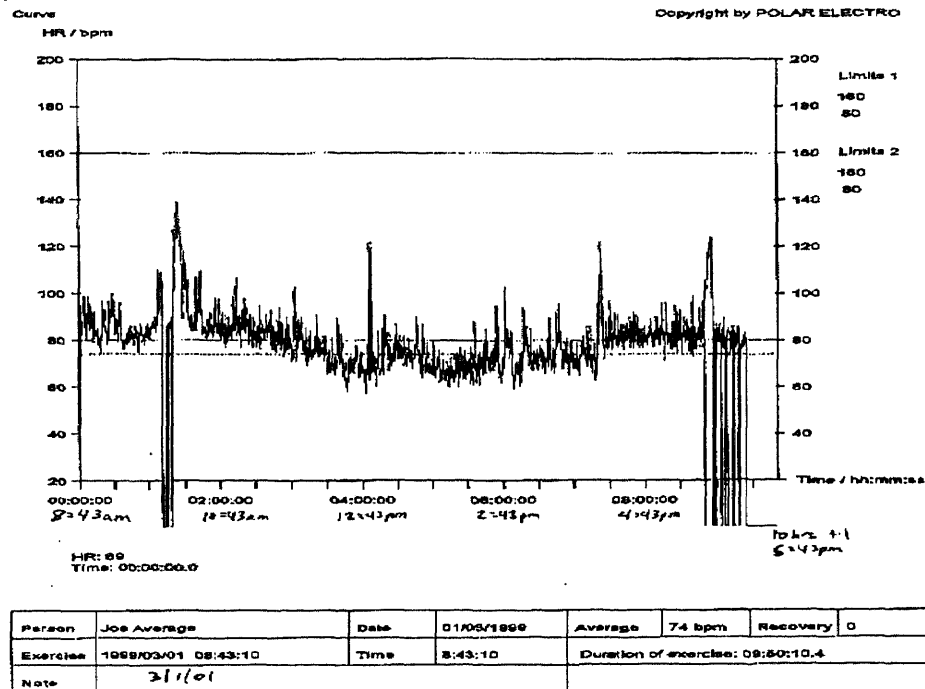

Figure 2.5 Raw 5s interval recording

In data acquisition, the sampling frequency is important for the type of signal you have. According to the sampling theorem, sampling frequency must be greater than two times the signal's highest frequency. The standard for ECG recordings is a sampling frequency of 250Hz. Since, the watch has the ability to record at 1,000 Hz, our recordings are fine.

12.2 Preprocessing

In Study 1, the raw HR data (Figure 2.5) was store as a text file (Tab delimited, *.txt).

Then, this file was open in MS Excel for clean up of the HR signal(Figure 2.6).

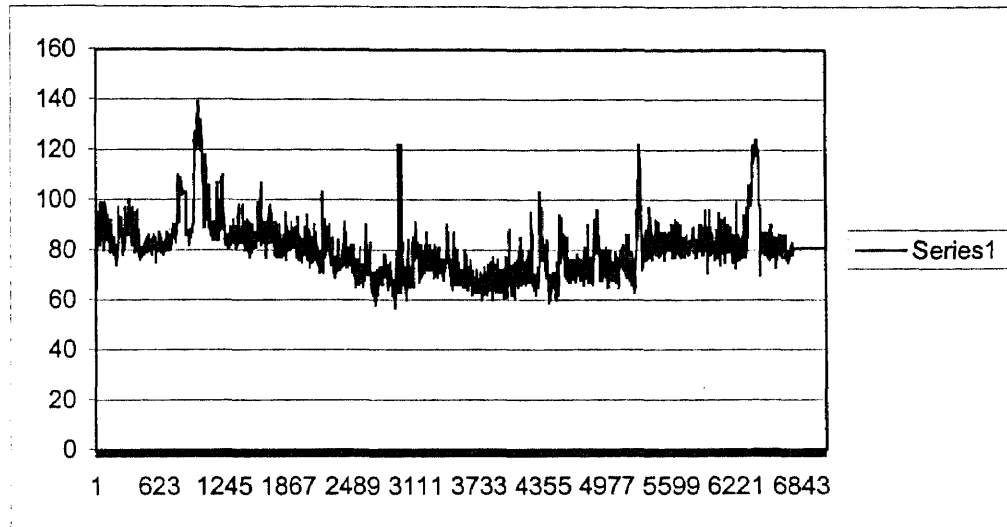

Figure 2.6 Cleaned text file

In this process, the HR signal recorded as zero values was replaced with the previous non-zero value. Next, the HR data in text file was converted to Interbeat Interval (IBI) file because the LabVIEW program only takes IBI data type. In the R-R HR data, the conversion factor to get IBI data type:

$$\text{IBI} = 12,000/\text{HR}$$

The conversion factor was derived in the following way:

1. The sampling rate was assumed to be 200samples/beat.
2. The average heart rate is assumed to be 60beats/min.
3. The conversion factor: $12,000 = 200 \times 60$.

In the 5sec HR data, the conversion factor to get IBI data type:

$$\text{IBI} = 60,000/\text{HR}$$

The 5sec conversion factor was derived in the following way:

1. The sampling rate was assumed to be 200samples/beat.
2. The average heart rate is assumed to be 60beats(R-R)/min.
3. The recording was made every 5 seconds.

The conversion factor: $60,000 = 200 * 60 * 5$.

500pts ($\approx 1\text{h}$) segment of the 5sec data was prepared for 1/f spectral analysis. For the R-R 1/f analysis, the entire 1h file was to be used. In Study 2, for the circadian rhythm spectral analysis, as noted in literature[13], 5sec 11h data were broken down into intervals of every 180pts($\approx 15\text{min}$). The raw data was cleaned the same way as Study 1. To get IBI, the 60,000/HR conversion factor was used. In Study 3, the 11h raw data was cleaned the same way as Study 1 and Study 2. The literature [17,18] suggested breaking the data into a 10min segment with the smallest number of abnormal beats. For our analysis, the data was broken down into 1/2h and 1hr data length to see if there were any differences.

2.3 Labview Algorithm

LabVIEW software was used to calculate 1/f in Study 1, circadian rhythm power spectra in Study 2, and the standard deviation in Study 3 (figure 2.7&2.8). LabVIEW stands for Laboratory Virtual Instrument Engineering Workbench. It is an instrumentation and analysis software that runs on PCs using Microsoft Windows. LabVIEW is a program development application that uses a graphical programming language, G, to create programs in flowchart-like form called block diagram. All block diagrams have the user interface linked to it such as the one in Figure 2.7 linked to the diagram in Figure 2.8.

Standard Deviation
5.14

Figure 2.7 Standard deviation VI: front panel/user interface

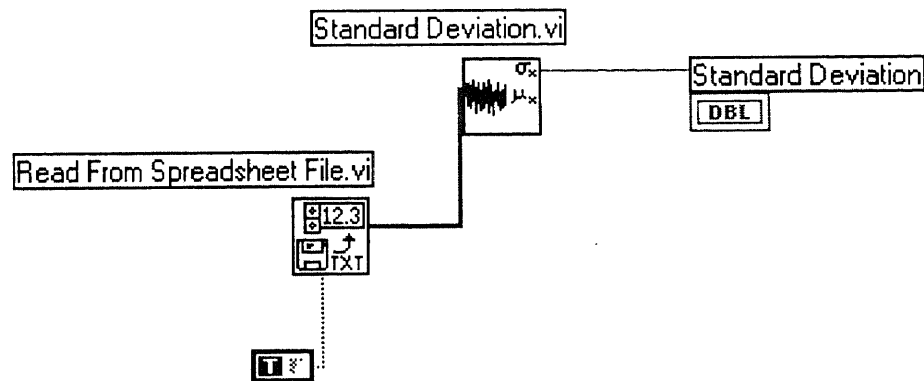

Figure 2.8 Standard deviation VI: diagram/graphical code

LabVIEW programs are called virtual instruments (VIs) because their appearance and operation imitate actual instruments. VIs have both an interactive user interface and a source code equivalent, and data can be passed between them. A VI has three main parts:

1. The front panel is the interactive user interface of a VI. The front panel can contain knobs, push buttons, graphs, and indicators to simulate the panel of an instrument.
2. The block diagram is the VI's source code. The block diagram is the actual executable program. The icons of a block diagram represent the built-in functions, lower VIs and program control structures. Wires are drawn to connect the icons indicating the flow of data in the diagram.
3. The icon and connector of a VI allow other VIs to pass data to the VI. The icon represents a VI in the block diagram of another VI. The connector defines the inputs and outputs of the VI. VIs are hierarchical.

Figure 2.9 shows a portion of the HR power spectrum VI's diagram and its components.

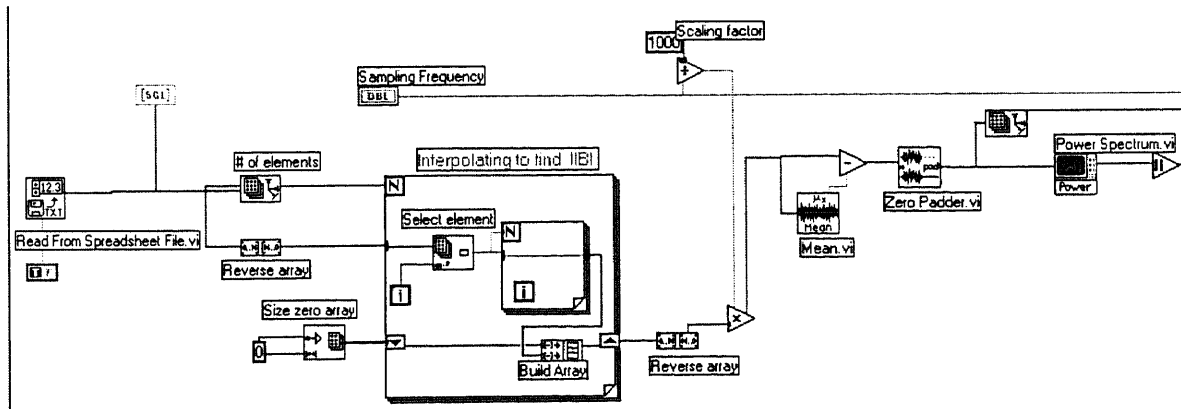

Figure 2.9 HR power spectrum: left side of diagram

The major components included:

- `read_from_spreadsheet` (read saved text format file that have columns and rows)
- `mean` (computes the mean of the values in the input sequence X)

$$\text{mean} = \text{Sum}\{X[i]\}/n$$

- `zero_padder` (resizes the input sequence to the next higher valid power of two, sets the new trailing elements to the sequence of zero, and leaves the first n elements unchanged where n is the number of samples in the sequence)
- `power_spectrum` (compute power spectrum, S_{xx} , of the input sequence)

$$S_{xx}=Y^2, \text{ where } Y=|\text{FFT}[x]|/n$$

Where FFT is the fast Fourier transform,
n is the number of elements in input sequence

- `write_to_spreadsheet` (create text file readable by most spreadsheets)
- `waveform_plot` (plots the power spectrum from 0.05 to 0.5Hz)

APPENDIX D showed the entire program. The program was implemented to calculate the power spectrum from the LF(0.05- 0.15Hz) and the HF(0.15-0.5Hz) ranges. It reads IBI data from spreadsheet file, plots a tachogram (R-R-interval), computes the power spectrum, computes the Lf and HF, and then computes the log-log power spectrum.

2.4 Benoit R/S Method

The fractal scaling beta is related to the Hurst exponent (H) for the non-linear dynamic analysis[17,18]:

$$H = (B-1)/2 \therefore B = 2H + 1$$

Benoit R/S method was used to calculate H. Figure 2.10 shows the parameters that were used to calculate the R/S line for the file 1027a. Parameters such as N (336), the number of data points used and number of window-interval lengths (11), the number of divisions of N from 10 to (N/2)-1. In the log scale, the equation of the line ($Y=1.82*X^{0.272}$) and the H (0.272) value were calculated.

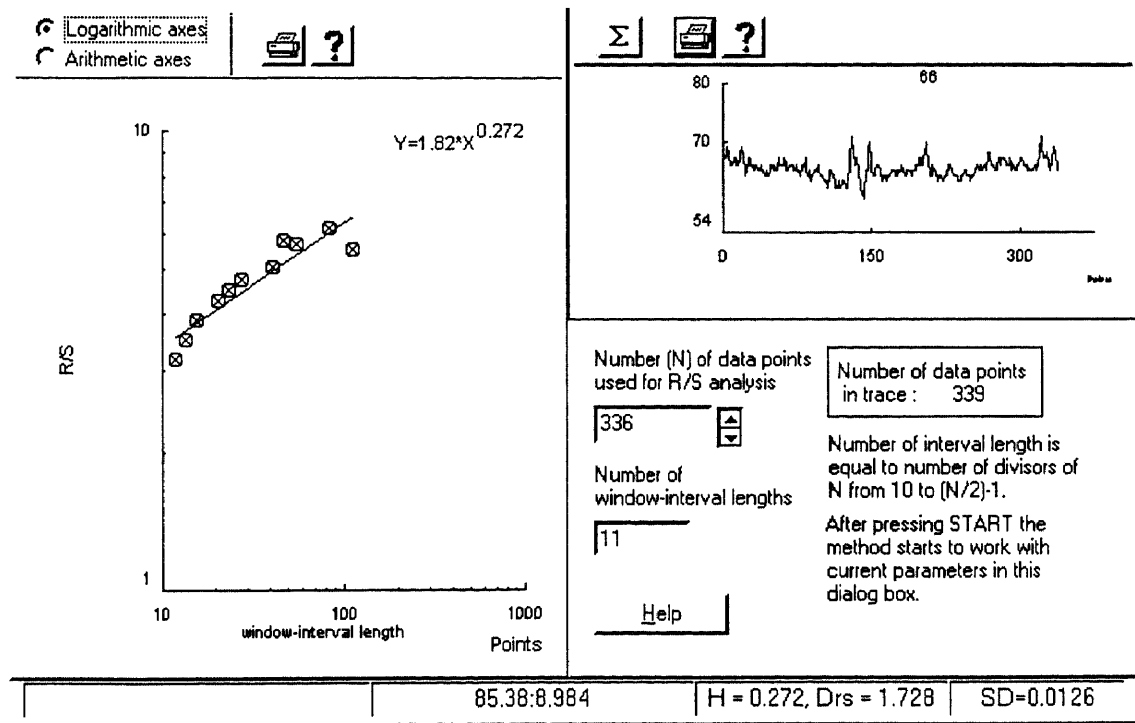

Figure 2.10 Benoit program: file 1027a R/S analysis.

R/S Analysis Method

Consider an interval, or window, of length w in a trace. Within this window, one can define two quantities:

$R(w)$, the range taken by the values of y in the interval. The range is measured with respect to a trend in the window, where the trend is estimated simply as the line connecting the first and the last point within the window. This subtracts the average trend in the window.

$S(w)$, the standard deviation of the first differences Δy (dy) of the values of y within the window. The first differences of the y 's are defined as the differences between the values of y at some location x and y at the previous location on the x axis:

$$dy(x) = y(x) - y(x - dx) \quad (1)$$

where Δx (dx) is the sampling interval, i.e., the interval between two consecutive values of x .

A reliable measurement of $S(w)$ requires data with a constant sampling interval dx , because the expected difference between successive values of y is a function of the distance separating them. $S(w)$ in the rescaled range method is used to standardize the range $R(w)$ to allow comparisons of different data sets; if $S(w)$ is not used, the range $R(w)$ can be calculated on data sets that have a non-constant sampling interval.

The rescaled range $R/S(w)$ is defined as:

$$R/S(w) = \left\langle \frac{R(w)}{S(w)} \right\rangle$$

(2)

where w is the window length and the angled brackets $\langle R(w) \rangle$ denote the average of a number of values of $R(w)$. The basis of the method is that, because of self-affinity, one expects the range taken by the values of y in a window of length w to be proportional to the window length to a power equal to the Hurst exponent H

, i.e.,

$$R/S(w) = w^H$$

(3)

In practice, for a given window length w , one subdivides the input series in a number of intervals of length w , measures $R(w)$ and $S(w)$ in each interval, and calculates $R/S(w)$ as the average ratio $R(w)/S(w)$, as in (2). This process is repeated for a number of window lengths, and the logarithms of $R/S(w)$ are plotted versus the logarithms of w . If the trace is self-affine, this plot should follow a straight line whose slope equals the Hurst exponent H . The fractal dimension of the trace can then be calculated from the relationship between the Hurst exponent H and the fractal dimension:

$$D_{rs} = 2 - H \quad (4)$$

where D_{rs} denotes the fractal dimension estimated from the rescaled range method.

CHAPTER 3

RESULTS

3.1 Study 1: 1/f

3.1.1 Study 1: 1/f rr data analysis

For the R-R 1/f analysis, the entire 1h file was the input to the HR power spectrum VI.

.From the log-log power spectrum, we calculate the slope of the spectrum to get the 1/f.

Figures 3.1 to 3.3 and Tables 3.1 to 3.3 showed the results from the 1/f spectral analysis.

In literature, it suggested that the slope of the line in the 0.001 – 0.4Hz was -1.2 for X. In

the 0.001- 0.4Hz (-3 to -0.398 log scale) range, RR2(Table 3.1) had a slope of -1.17 with

R^2 of 0.42 and RR3(Table 3.2) had a slope of -1.58 with R^2 of 0.58. The R-R data, in

term of the slopes and R^2 values, RR2 and RR3 results agreed with each other and were

consistent with the findings in the literature[13,15].

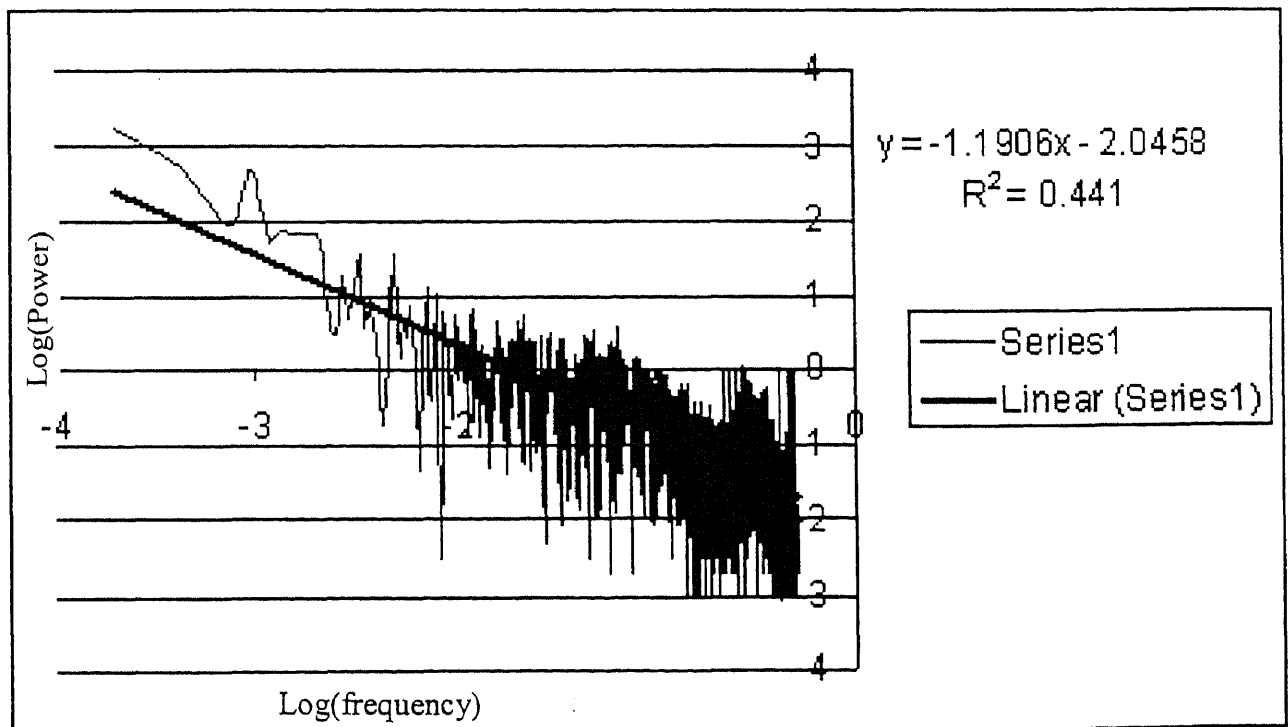

Figure 3.1 RR2: Log(Power) vs. Log(freq)

Table 3.1 1/f result: RR2 regression line.

FREQUENCY BAND	LINE	
0.001 - 0.4 Hz	$Y = -1.1723X - 2.0319$	$R^2 = 0.4205$
0.001 - 0.01 Hz	$Y = -2.1802X - 4.4423$	$R^2 = 0.4391$
Start - 0.01 Hz	$Y = -2.0142X - 4.0683$	$R^2 = 0.5949$

Table 3.2 1/f result: RR3 regression line.

FREQUENCY BAND	LINE	
0.001 - 0.4 Hz	$Y = -1.5787X - 1.2975$	$R^2 = 0.5753$
0.001 - 0.01 Hz	$Y = -0.8229X - 0.5524$	$R^2 = 0.2418$
Start - 0.01 Hz	$Y = -0.9241X - 0.7708$	$R^2 = 0.4153$

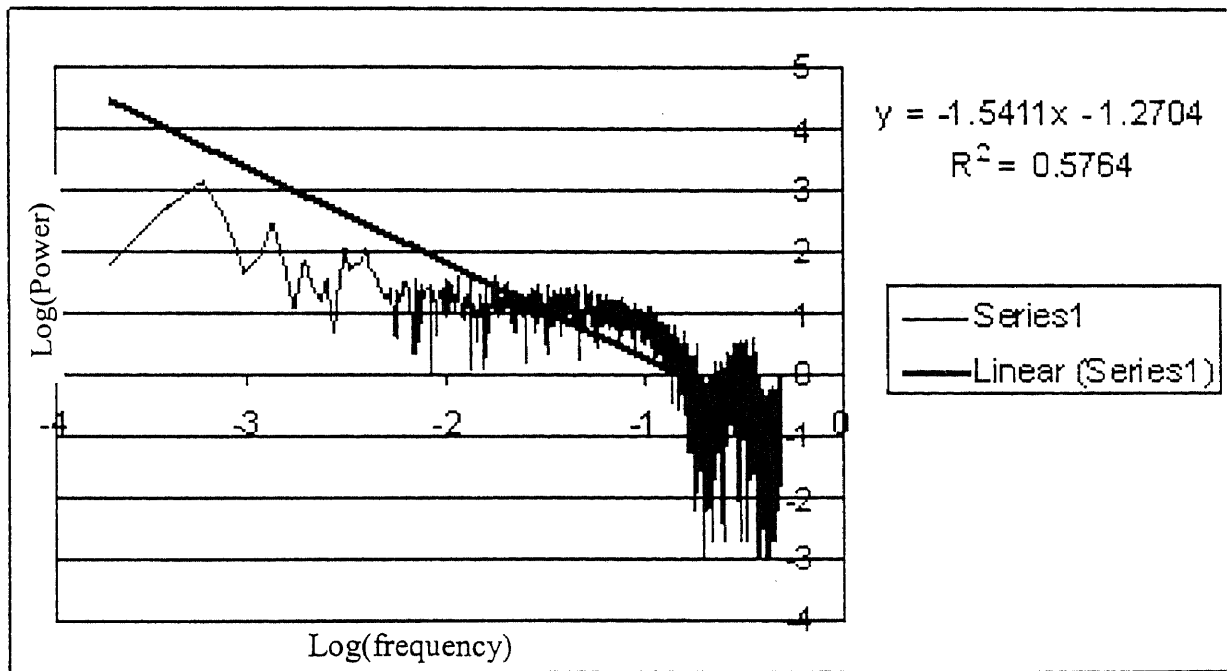
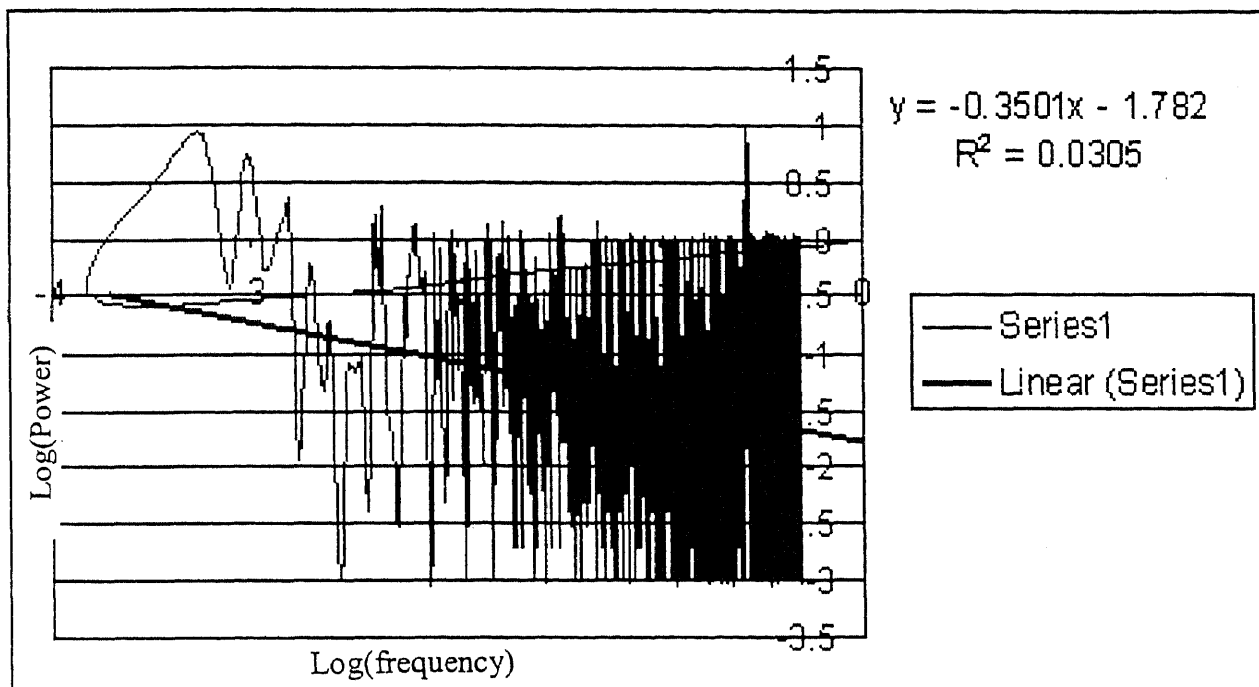

Figure 3.2 RR3: Log(Power) vs. Log(freq)

Table 3.3 1/f result: RR1 regression line.

FREQUENCY BAND	LINE	
0.001 - 0.4 Hz	$Y = -0.3494X - 1.7805$	$R^2 = 0.0299$
0.001 - 0.01 Hz	$Y = -2.046X - 6.2124$	$R^2 = 0.3461$
Start - 0.01 Hz	$Y = -1.4628X - 4.7251$	$R^2 = 0.2606$

**Figure 3.3** RR1: Log(Power) vs. Log(freq).

3.1.2 Study 1: 1/f 5sec results

The three 1h length 5sec data files were input into the HR power spectrum program and the results are given in Tables 3.4 to 3.6 and Figures 3.4 to 3.6. In the 0.001-0.4Hz (-3 to -0.398 log scale) range, 5sec1 had a slope of -1.99 with R^2 of 0.69, 5sec2 had a slope of -1.87 with a R^2 of 0.65, and 5sec3 had a slope of -1.94 with R^2 of 0.67. In term of the slopes and R^2 values, the 5sec1, 5sec2, and 5sec3 results agreed with each other and were consistent with the findings in the literature[13,15].

Table 3.4 1/f results: 5sec1 regression line.

FREQUENCY BAND		
0.001 - 0.4 Hz	$Y = -1.9948X - 1.8697$	$R^2 = 0.6889$
0.001 - 0.01 Hz	$Y = -0.5288X + 1.3915$	$R^2 = 0.1535$
Start - 0.01 Hz	$Y = -0.6931X + 1.0202$	$R^2 = 0.3036$

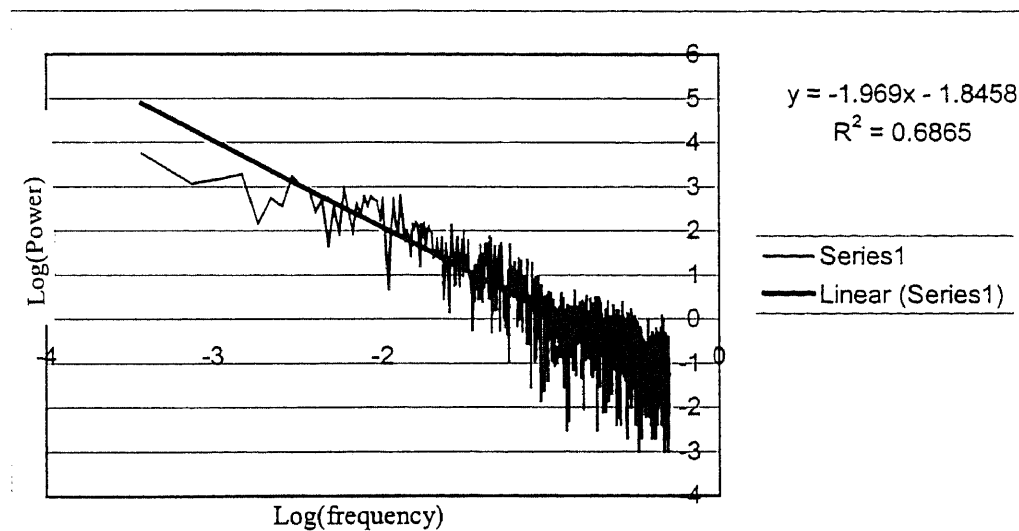

Figure 3.4 5sec1: Log(Power) vs. Log(freq).

Table 3.5 1/f results: 5sec2 regression line.

FREQUENCY BAND		
0.001 - 0.4 Hz	$Y = -1.8684X - 1.9511$	$R^2 = 0.6528$
0.001 - 0.01 Hz	$Y = -0.7201X - 0.0187$	$R^2 = 0.112$
Start - 0.01 Hz	$Y = -0.7137X - 0.0044$	$R^2 = 0.1546$

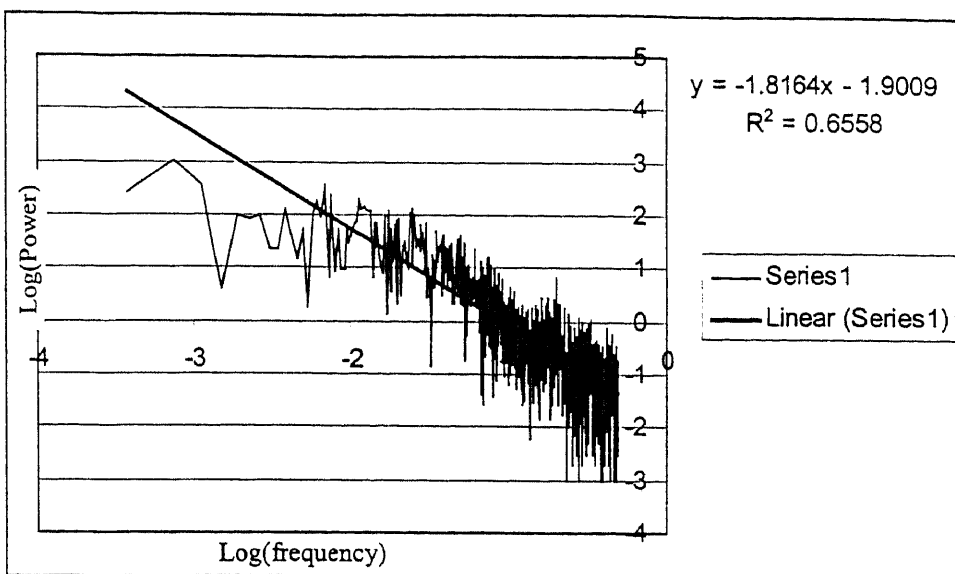

Figure 3.5 5sec2: Log(Power) vs. Log(freq).

Table 3.6 1/f results: 5sec3 regression line.

FREQUENCY BAND		
0.001 - 0.4 Hz	$Y = -1.9423X - 1.9609$	$R^2 = 0.6732$
0.0001 - 0.01 Hz	$Y = -0.0324X + 2.1309$	$R^2 = 0.0003$
Start - 0.01 Hz	$Y = -0.4035 + 1.1457$	$R^2 = 0.0488$

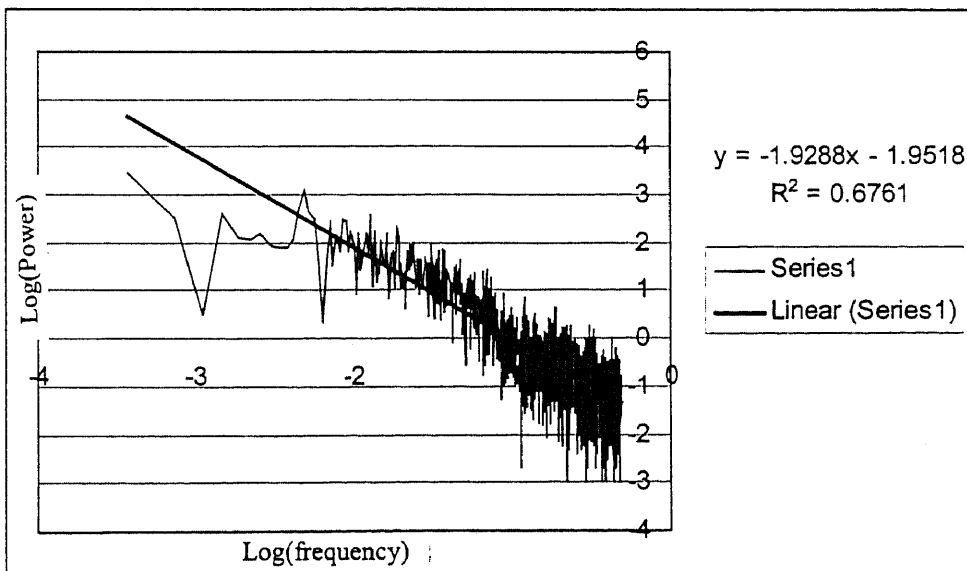

Figure 3.6 5sec3: Log(Power) vs. Log(freq).

3.2 Study 2: Circadian Rhythm Results

In this analysis, the HR power spectrum program was used to calculate the LF and HF for every 15min segment. A total of 45 LF and HF were calculated for the 11h period. After computing the power spectrum for all the segments, the LF and HF powers were plotted vs. time. The results are shown in Figure 3.7 to Figure 3.10. According to the literature, we show sec an increase in LF region from 6am to 10am and the HF region should increase in the evening. Our results revealed three things. First, the LF and HF regions increased and decreased simultaneously, which was not consistent with the findings in the literature. Second, the LF regions increased from 6am-10am throughout the three day recording (Figures 3.7,3.9&3.10) which was consistent with the findings in the literature. Lastly, both the LF and HF in all the figures showed the 2h circadian rhythm. Over all, our results showed that, though there are evidence of some circadian rhythm, the results are not conclusive enough to say that there was a 24h circadian rhythm.

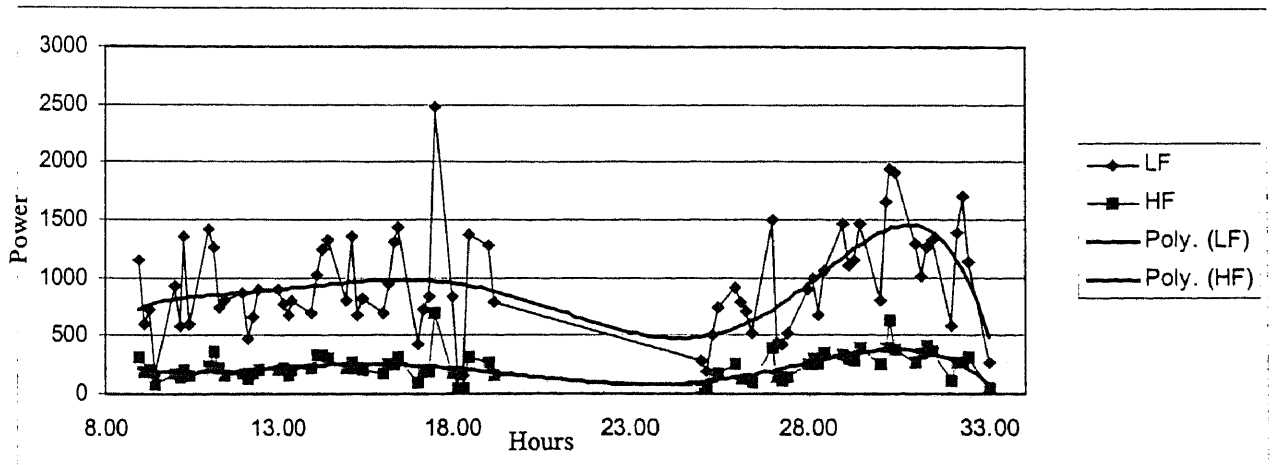

Figure 3.7 Circadian rhythm: 1st day 8am to 2nd day 5pm.

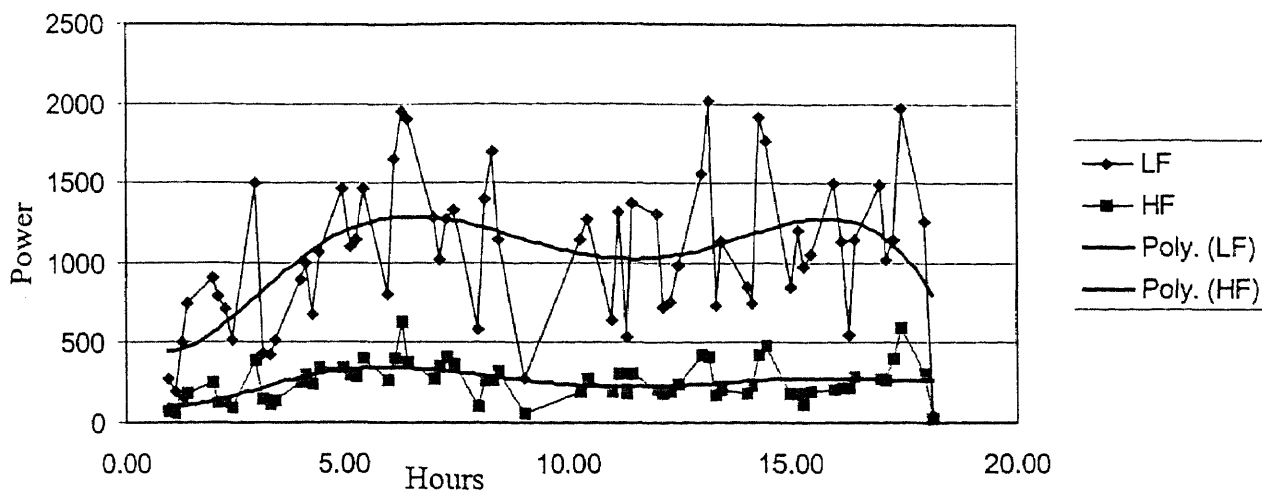

Figure 3.8 Circadian rhythm: 2nd day 12am to 2nd day 6pm.

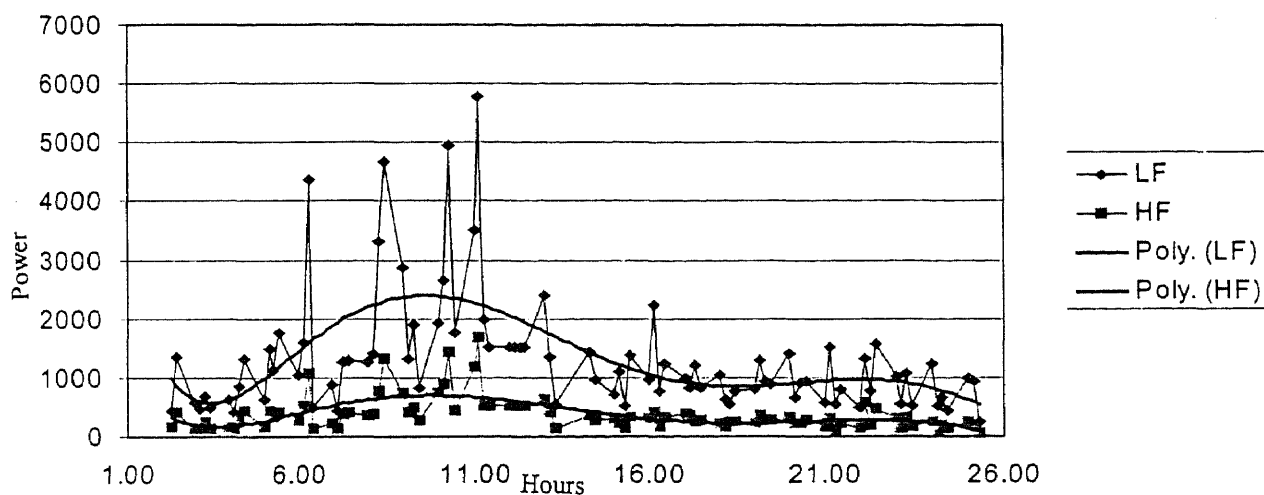

Figure 3.9 Circadian rhythm: 3rd day 1am to 4th day 1am.

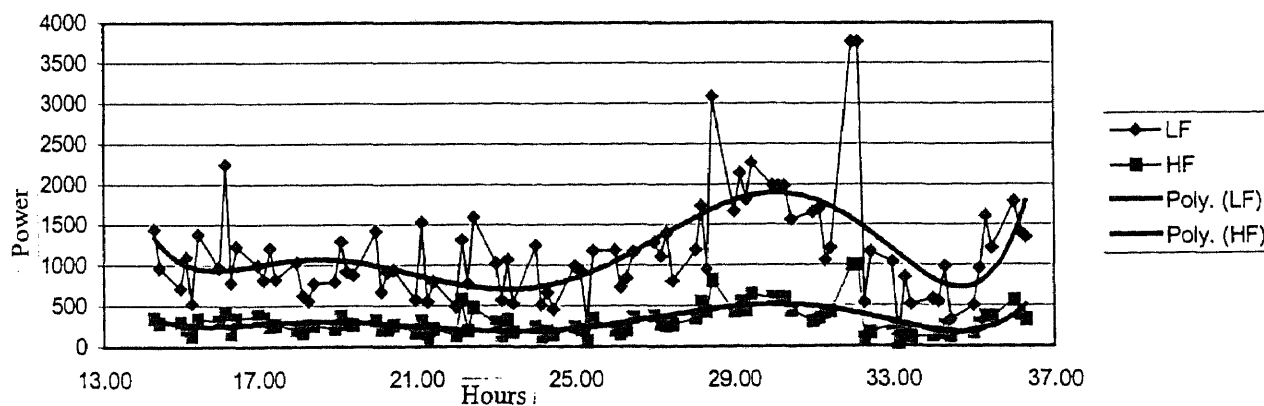

Figure 3.10 Circadian rhythm: 3rd day 1pm to 4th day 12noon.

3.3 Study 3: Non-Linear Dynamics Results

In this analysis, the 17 data files from the 5 subjects were cut into 1h and ½ hr segments. The 1h segment results are listed in Table 3.7 and Figures 3.11&3.12. Table 3.7 and Figure 3.12 revealed that healthier subjects agd (3.85), id (4.53), kp (6.12), and sk (3.86&5.14 after 4/30/98) had much higher standard deviation averages than less healthy subjects mm (2.17), sk (1.69, 3.4, &2.51 before 4/30/98). This finding is consistent with the findings in the literature suggesting that healthier subjects had higher variability in their HR. Table 3.7 and Figure 3.11 also revealed that healthier subjects id (1.53), and sk (1.33 after 6/20/98) had beta averages clearly closer to 1.0 than less healthier subject sk (1.74 before 2/18/98). This finding is also consistent with the findings in the literature [17,18] suggesting that the healthier subjects' HR was more fractal than the less healthy subjects.

Table 3.7 Non-linear dynamics: 1h(720pts).

Subject	File	H	Beta	Std. D.	Beta ave.	Std. D. ave.
sk 4/30/98	1027a	0.329	1.658	3.91		
sk 5/26/98	1127a	0.299	1.598	3.81	1.63	3.86
sk 6/20/98	1333a	0.166	1.332	5.14	1.33	5.14
mm 11/7/97	322a	0.312	1.624	2.41		
mm 11/11/97	335a	0.259	1.518	1.93	1.57	2.17
agd 12/12/97	458a	0.229	1.458	3.79		
agd 12/18/97	459a	0.377	1.754	2.8		
agd 12/22/97	479a	0.211	1.422	4.95	1.54	3.85
id 12/29/97	525a	0.263	1.526	4.53	1.53	4.53
kp 1/24/98	630a	0.346	1.692	8.76		
kp 1/30/98	663a	0.355	1.71	3.47	1.70	6.12
sk 1/18/98	765a	0.37	1.74	1.69	1.74	1.69
sk 2/18/98	818a	0.381	1.762	3.71		
sk 3/2/98	840a	0.24	1.48	3.09	1.62	3.4
sk 3/25/98	917a	0.339	1.678	2.59		
sk 4/4/98	934a	0.361	1.722	2.72		
sk 4/22/98	989a	0.183	1.366	2.23	1.59	2.51

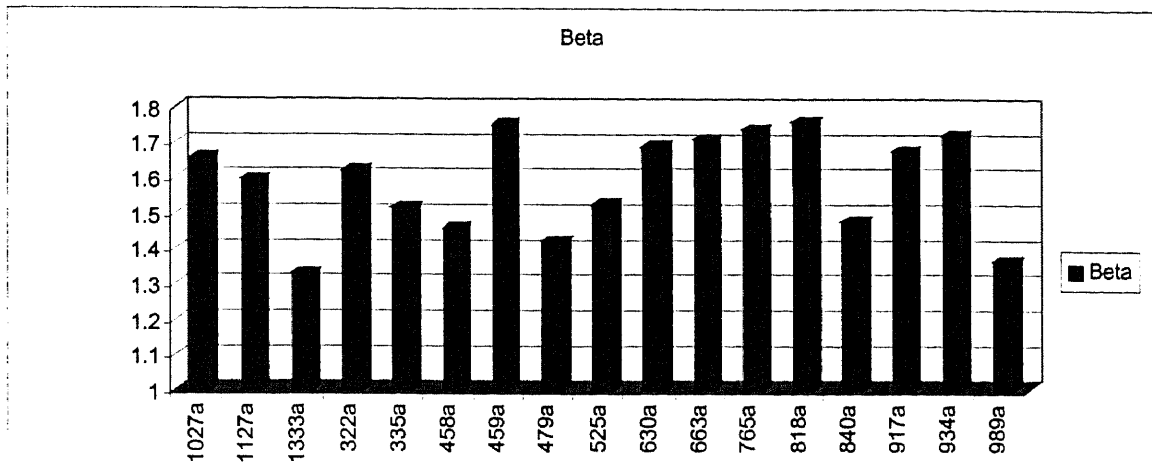

Figure 3.11 Fractal measurement: beta(1h)

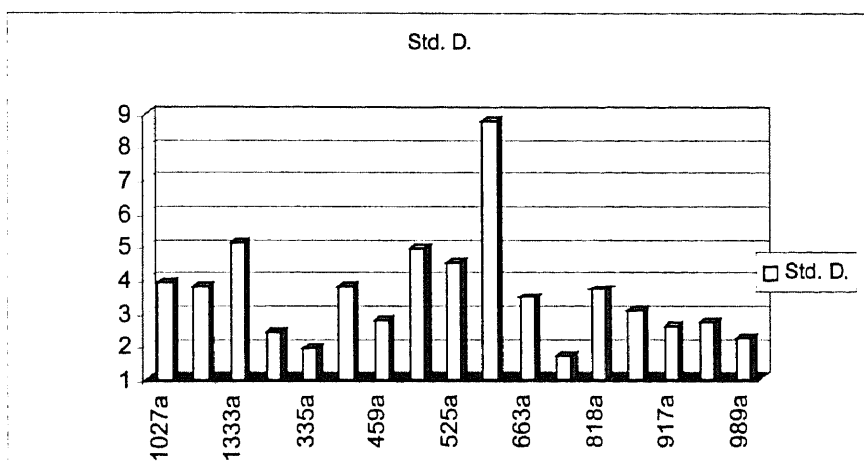

Figure 3.12 Variability measurement: standard deviation (1h)

The 1/2h results are listed in Table 3.8 and Figures 3.13&3.14. Table 3.8 and Figure 3.13 again revealed that healthier subjects agd (3.0), id (4.58), kp (5.58), sk (4.1 after 6/20/98) had much higher standard deviation averages than the less healthy subjects mm (1.85), sk (1.42, 1.87 & 2.35 before 4/30/98). Table 3.8 and Figure 3.14 also revealed that healthier subjects agd (1.44), and sk(1.33 after 6/20/98) had beta averages clearly closer to 1.0 than less healthier subjects sk (1.66 before 2/18/98) and mm(1.54).

Table 3.8 Non-linear dynamics: 1/2h(360pts).

Subject	File	H	Beta	Std. D.	Beta ave.	Std. D. ave.
sk 4/30/98	1027a	0.311	1.622	1.77		
sk 5/26/98	1127a	0.231	1.462	1.53	1.54	1.65
sk 6/20/98	1333a	0.166	1.332	4.1	1.33	4.1
mm 11/7/97	322a	0.299	1.598	1.96		
mm 11/11/97	335a	0.237	1.474	1.73	1.54	1.85
agd 12/12/97	458a	0.173	1.346	3.52		
agd 12/18/97	459a	0.27	1.54	1.62		
agd 12/22/97	479a	0.213	1.426	3.87	1.44	3.00
id 12/29/97	525a	0.311	1.622	4.58	1.62	4.58
kp 1/24/98	630a	0.351	1.702	8.67		
kp 1/30/98	663a	0.19	1.38	2.49	1.54	5.58
sk 1/18/98	765a	0.332	1.664	1.42	1.66	1.42
sk 2/18/98	818a	0.235	1.47	2.16		
sk 3/2/98	840a	0.176	1.352	1.58	1.41	1.87
sk 3/25/98	917a	0.307	1.614	2.44		
sk 4/4/98	934a	0.383	1.766	2.65		
sk 4/22/98	989a	0.174	1.348	1.95	1.58	2.35

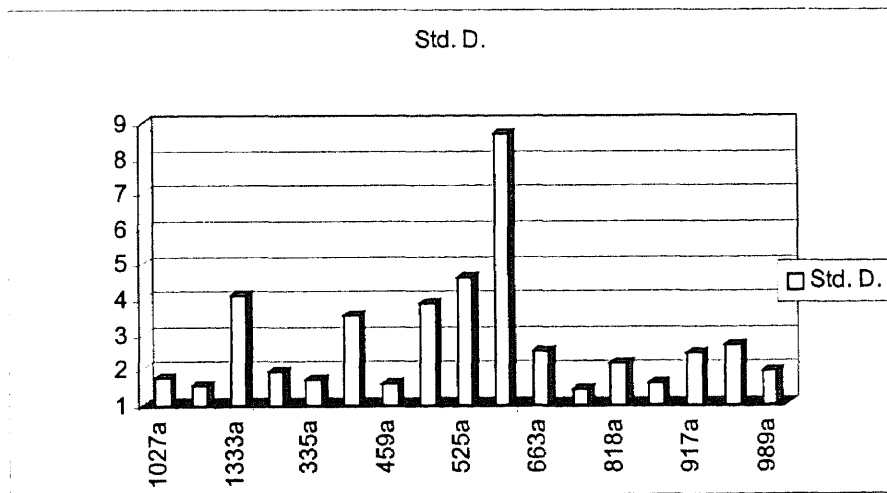

Figure 3.13 Variability measurement: standard deviation(1/2h)

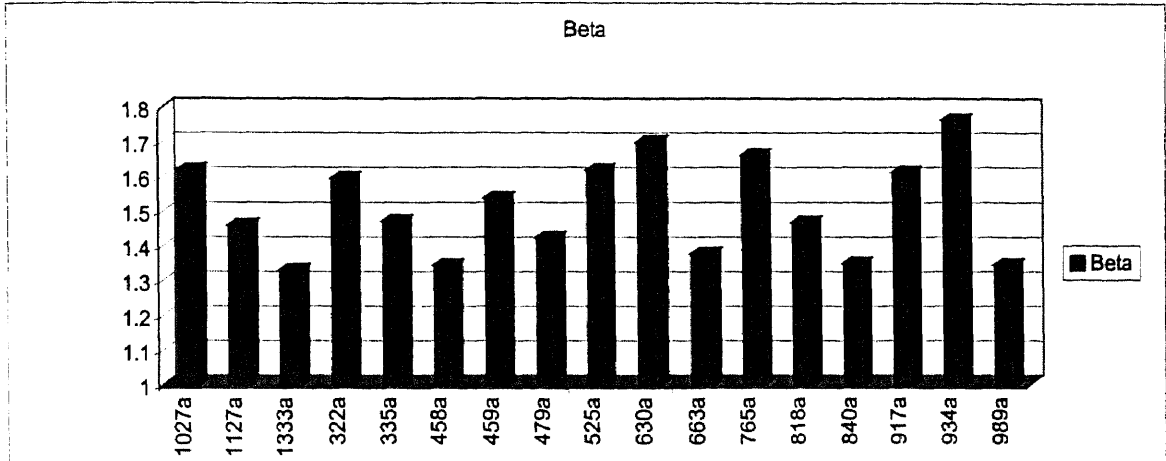

Figure 3.14 Fractal measurement: beta(1/2h)

For both the 1h and 1/2h data, the results were consistent with the findings in literature [17,18]. The results seemed indicate that the non-linear dynamic measure (beta) with the linear dynamic measure (standard deviation) can separate the healthy subjects from the sick subjects and the result also seemed to indicate that these measure can separate the same subject during healthier state from a less healthy state.

CHAPTER 4

CONCLUSIONS AND FUTURE STUDIES

In conclusion, the goal of this project was to analyze long-term heart rate variability (HRV). We have reached our goal of learning and applying the techniques cited in the literature. In study 1, our results showed that $1/f$ was present from the frequency range of 0.0001 to 0.1Hz in a normal subject at rest. $1/f$ noise has been found in other biological systems, such as the alpha component of the EEG, and neuronal axons. Some proposed mechanisms for the physical origin of $1/f$ noise have involved the number and mobility of charged particles in the system, and this could be applied to the receptors, central neural integrators and effectors (autonomic nerves and SA node) involved in the control of heart rate [15]. The $1/f$ noise may be a fundamental feature of normal cardiovascular regulation. To find out the origin of $1/f$ noise in heart rate, studies would include isolated SA node, neuronal conduction, and the effects of physical activity. Since the $1/f$ investigation was a pilot study in our lab, a future study for our lab would be to investigate $1/f$ with a bigger population with variety in age and sex, and a more controlled study such as using paced breathing and at rest.

In study 2, our results didn't show the 24h circadian rhythm, but the 2h rhythm was present. Ichimaru [13] found that circadian rhythmicity was found in comatose patients. Circadian changes of HR were observed in the brain dead patient. This showed that the HR rhythm must be generated in the central nervous system by the central rhythm generator. This finding is important because it showed that long term changes of HRV might be modified by the central nervous system and clinically may be useful in the assessment in patients with coma. Our results also proved to be useful. The possibilities

of using this technique to see long-term trends and the circadian changes of HR is very exciting. Since this investigation about the circadian rhythm was a pilot study in our lab, it would be very interesting to see a bigger study with more subjects, and more controls.

In study 3, we confirmed the findings of the fractal nature (non-linear dynamics) of HRV. By using the linear measure (standard deviation) and non-linear measure (Beta), we can differentiate the healthy subjects from the cardiac patients. By using the two measures, we were able to differentiate the healthier subjects from the sick subjects. Future studies are needed to understand the physiological mechanisms responsible for the origin of fractal HRV. Yamamoto et .al. [17,18] found the importance of the parasympathetic nervous system in mediating the fractal component of HRV in humans. They also found that normal human HRV has H near 0, indicating an inverse correlation in resting HRV signal. Physiologically, this inverse correlation may be thought of as being compatible with a well-regulated state (through negative feedback), since an increase in HRV is likely followed by a decrease. Further, when stress was applied in the resting state by physical exercise, the correlation seemed to be lost, with increase in H and Beta. An interesting study would be to investigate the relationship between fractal properties of HRV and cardiovascular regulation. Also recently, it has been proposed that there is another family of parameters or complexity in data called the approximate entropy. It would be interesting to apply this measure to the non-linear dynamics of HRV [17,18]. Again, since this investigation was a pilot study in our lab, it would be interesting to see what the results would be to apply the Beta measure and the standard deviation measure to a bigger population study.

These three studies confirmed that long-term HRV recording and analysis are important in understanding the activities of the autonomic nervous system (the sympathetic and the parasympathetic nervous systems) because the autonomic nervous system that controls the rhythm generator is the same as that affects the HRV. Moreover, by breaking down the power spectrum into LF and HF we were able to see the activities of the PSN in the HF region and the combination of PNS and SNS in the LF region. Furthermore, by breaking the HRV analysis into the non-linear dynamics and linear dynamics, we were able to separate the healthier subjects from the cardiac patients.

APPENDIX A

Table A.1 Polar watch disease results

Diseases			
	LF	HF	LF/HF
Power spectral density			
myocardial infarction (MI)	>	<	>
MI after 2 weeks at rest	>>	<<	>>
MI after 2 weeks & tilt	>>	<<	>>
MI after 6 months at rest	>	<	>>
MI after 6 months & tilt	>>	<	>>
chronic congestive heart failure: rest	<<	<<	
chr. cong. heart failure: ergometrie	<<	<<	
chr. cong. heart failure: recovery	<<	<<	
angina pectoris	>	<	>
ventricular arrhythmia	>	<	>
coronary artery disease	=	<	>
mitral valve prolaps	=	<	>
sudden death	=	<	>
supraventricular arrhythmias	>	<	>
cardiac transplantat: rest	<<	<<	
cardiac transplantat: ergometry	<<	<<	
cardiac transplantat: recovery	<<	<<	
cardiac transplantat: reinnervation	=	=	=
cardiac transplantat: rejection	broad band	broad band	
hemorrhagic shock	>>	>>	>>
migraine headache	>	<	>

**APPENDIX A
(Continued)**

Table A.2 Polar watch disease results continued[6]

migraine headache	>	<	>
essential hypertension: rest	>	=	>
essential hypertension: tilt	>>	=	>>
essential hypertension: day (at rest)	>>	<	>
essential hypertension: night (at rest)	>	=	>
diabetic neuropathy: mild	<	<	=
diabetic neuropathy: severe	<<	<<	=
diabetic neuropathy: tilt	(>)	<	>
smoking: acute	>	<	>
smoking: chronic	=	<<	>
SIDS risk	>	<	>
tetraplegie	∅	=	
stress	>	<	>

> increase, < decrease, = no changes, multiple arrow = intensity, () slightly, ∅ not existant

**APPENDIX A
(Continued)**

Table A.3 Polar watch physiological results[6]

Physiological changes in humans

Power spectral density	LF	HF	LF/HF
tilt (passive orthostatic)	>>	<<	>>
standing up (active orthostatic)	>>	<	>
control breathing & rest	<	>	<
control breathing & tilt	>	<	>
arithmetic calculation (stress)	>	<	>
circadian rhythm: night	<	>	<
circadian rhythm: morning	>	<	>
ergometrie: 50% VO2 max.	>	<	>
ergometrie: recovery	(>)	(<)	(>)
β -blockade: acute & rest	<	>	<
β -blockade: acute & tilt	>	<	>
β -blockade: chronic & rest	<<	>>	<<
β -blockade: chronic & tilt	(>)	=	(>)
atropine: standard dose	<	<<	<
atropine: low dose	=	>	>
atropine: high dose	<	<<	<

> increase, < decrease, = no changes, multiple arrow = intensity, () slightly

APPENDIX B

Polar Vantage NV™ recorder is one of the most advanced and sophisticated heart rate monitor in the world offering features and performance exceeding any other heart rate recorder available, including:

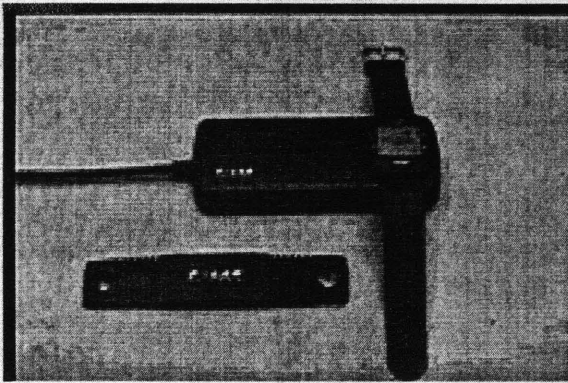

Figure B.1 Polar Vantage NR chest electrode and watch-computer interface system[6]

Watch Settings	
Time of day 18 : 49 : 00	12/24h Disp. <input type="radio"/> 12h <input checked="" type="radio"/> 24h
Date 02 . 02 . 1997	
Alarm 10 : 00 : 00	<input type="checkbox"/> Alarm On
	System Time
	Set Receiver
	Cancel

Figure B.2 Polar watch settings[6]

**APPENDIX B
(Continued)**

Measure Settings	
Current Settings: []	ID NU <input type="checkbox"/> Set ID
Interval <input checked="" type="radio"/> RR/HRU <input type="radio"/> Int <input type="radio"/> 5s <input type="radio"/> 15s <input type="radio"/> 60s	Limits Upper 1: [140] Lower 1: [80] Upper 2: [160] Lower 2: [100] Anaer. thres.: [160] Aer. thres.: [80]
Timers Timer 1: [00] : [00] mm:ss Timer 2: [00] : [00] mm:ss	<input type="button" value="Read Rec"/> <input type="button" value="Set Rec"/>
Recovery <input checked="" type="radio"/> Time [0] bpm <input type="radio"/> HR [00] : [00] mm:ss	Limit Alarms <input type="checkbox"/> Upper <input type="checkbox"/> Lower <input type="button" value="Special"/> <input type="button" value="Cancel"/>

Figure B.3 Polar watch measure settings[6]

Special options	
Relaxation/Lap <input checked="" type="radio"/> Relaxation <input type="radio"/> Lap <input type="radio"/> Relaxation/Lap	Reception distance <input checked="" type="radio"/> Long <input type="radio"/> Short (70%)
Delete files <input type="radio"/> Automatic <input checked="" type="radio"/> Manual	Time display <input checked="" type="radio"/> Split <input type="radio"/> Time
User Information: []	
<input type="button" value="Cancel"/> <input type="button" value="OK"/>	

Figure B.4 Polar watch special options[6]

APPENDIX B (Continued)

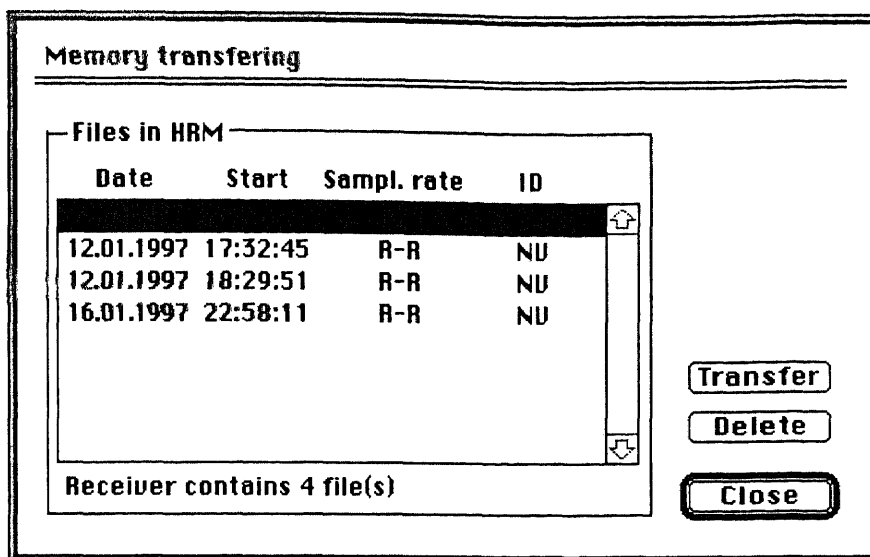

Figure B.5 Polar watch memory transferring

Heart Rate Monitoring Functions

- wireless heart rate monitoring with ECG accurate continuous measurement
- coded, digital transmission of HR
- maximum, average and minimum HR for the recording
- two range of heart rate reception distance

Recording Functions

- can record up to 134 hours
- file identification (date, time, etc.)
- automatic recording with RR(beat to beat)-intervals and every 5, 15, 60s
- ability to receive/transmit both analog and digital HR signal
- ability to record at 1000 Hz

Data Transfer Functions with the Interface (Figure B.6)

- ability to download performance data into a computer for detailed analysis

- ability to upload setting for watch and HRM from PC
- ability to show user's ID on the display of the receiver

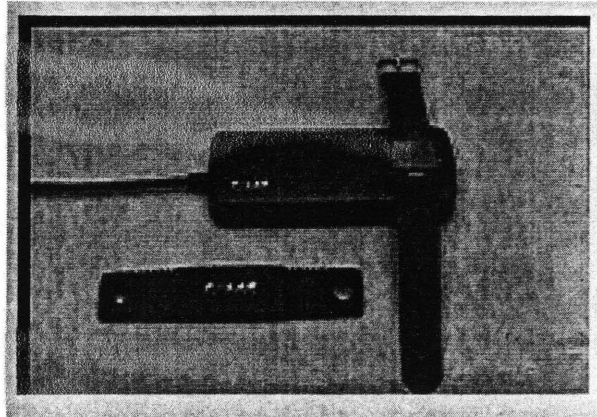

Figure B.6 Watch-interface system

Wearing the Polar Vantage NV HRM

1. Attach the elastic strap to the Polar Transmitter.
2. Wet the grooved electrode areas on the backside of the Polar Transmitter.
3. Adjust the strap length and secure the Polar transmitter around your chest to fit comfortably. Lock the buckle.
4. Check that the grooved and wet electrode areas are against your skin and the Polar logo is in the central upright position (Figure B.7).
5. Put on the Receiver as you would put on an ordinary watch.

APPENDIX B (Continued)

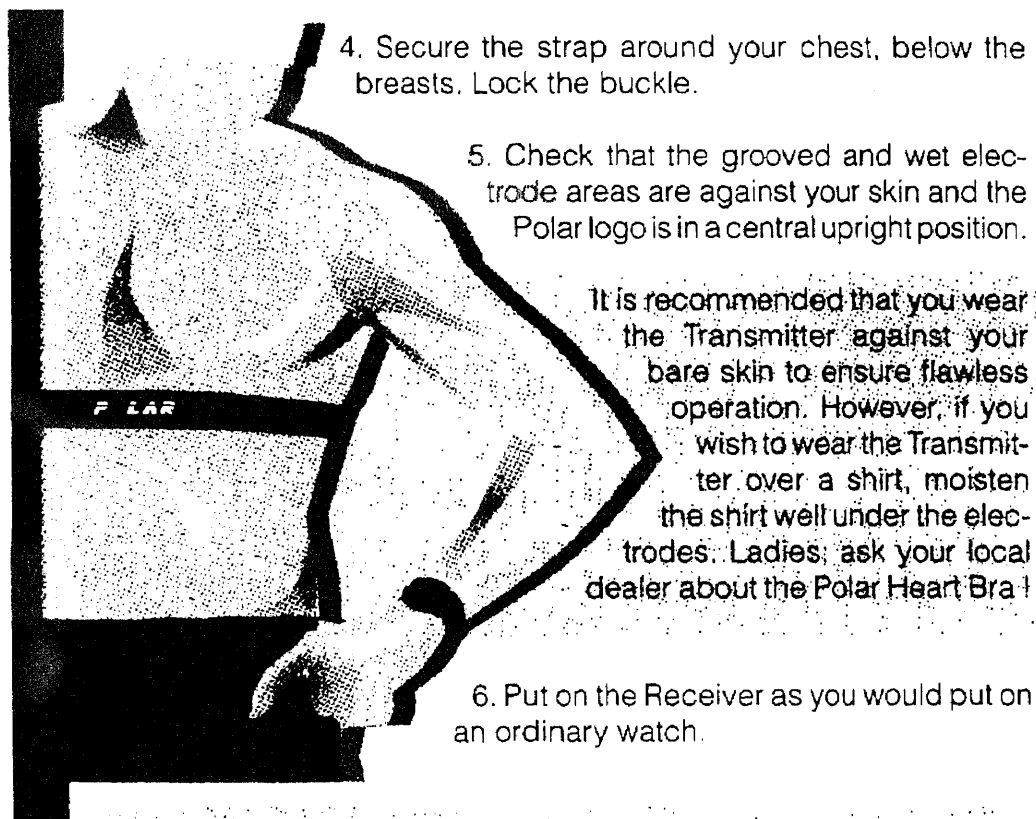

Figure B.7 Wearing the heart rate monitor (HRM)

Setting the HR Limits 1&2

1. Press SET/START/STOP (lower left button in Figure 2.2).
HR Limits 1 is the third block of the graphic bar on the right.
The HR Limit 1 starts to flash.
The upper reading is the Upper Limit 1, starts to flash.
2. Press SIGNAL/LIGHT to select the value.
The range is 10 – 240.
3. Press STORE/LAP/RECOVERY to lock selection.
4. Repeat step 1 to set Limit 2.
The HR Limits 2 is the fourth block of the graphic bar.

Changing the Recording Interval

1. Press SELECT (upper right button in Figure 2.2) to enter the FILE mode, where you can recall the results recorded during the exercise period.

APPENDIX B (Continued)

FILE starts flashing.

LEFT and FILES start scanning on the display.

INT starts flashing on the display.

2. Press SIGNAL/LIGHT (lower right button in Figure 2.2) to change the recording interval.

INT and the symbol of the current selection for the recording is flashing on the lower right corner of the display.

Table B.1 Recording interval alternatives

RECORDING INTERVAL	HR RECORDING	FULL MEMORY
RR	Every heart beat	4000 heart beats
5s	Every 5 seconds	11h 13min
15s	Every 15 seconds	33h 41min
60s	Every 60 seconds	124h 46min

The R-R-recording indicates the HRV and measures the time in milliseconds between two successive heart beats. R-R-recording is suitable for measuring HRV in non-exercise and at resting situations. It's recommended to use Contact Gel (ECG gel) to ensure good contact between skin and transmitter. It's suggested to minimized the use of lap times, timers and backlight functions to avoid disturbance during R-R-recording.

Starting the heart rate measurement

1. Wear the Transmitter and the Receiver.
2. In the Time of Day mode, press the STORE/LAP/RECOVERY(red button).
 - HRM starts.
 - The search for transmission code starts.
 - The HR reading starts to appear on the button line
 - Stopwatch starts running.
 Automatic recording of heart rate information starts.

APPENDIX C

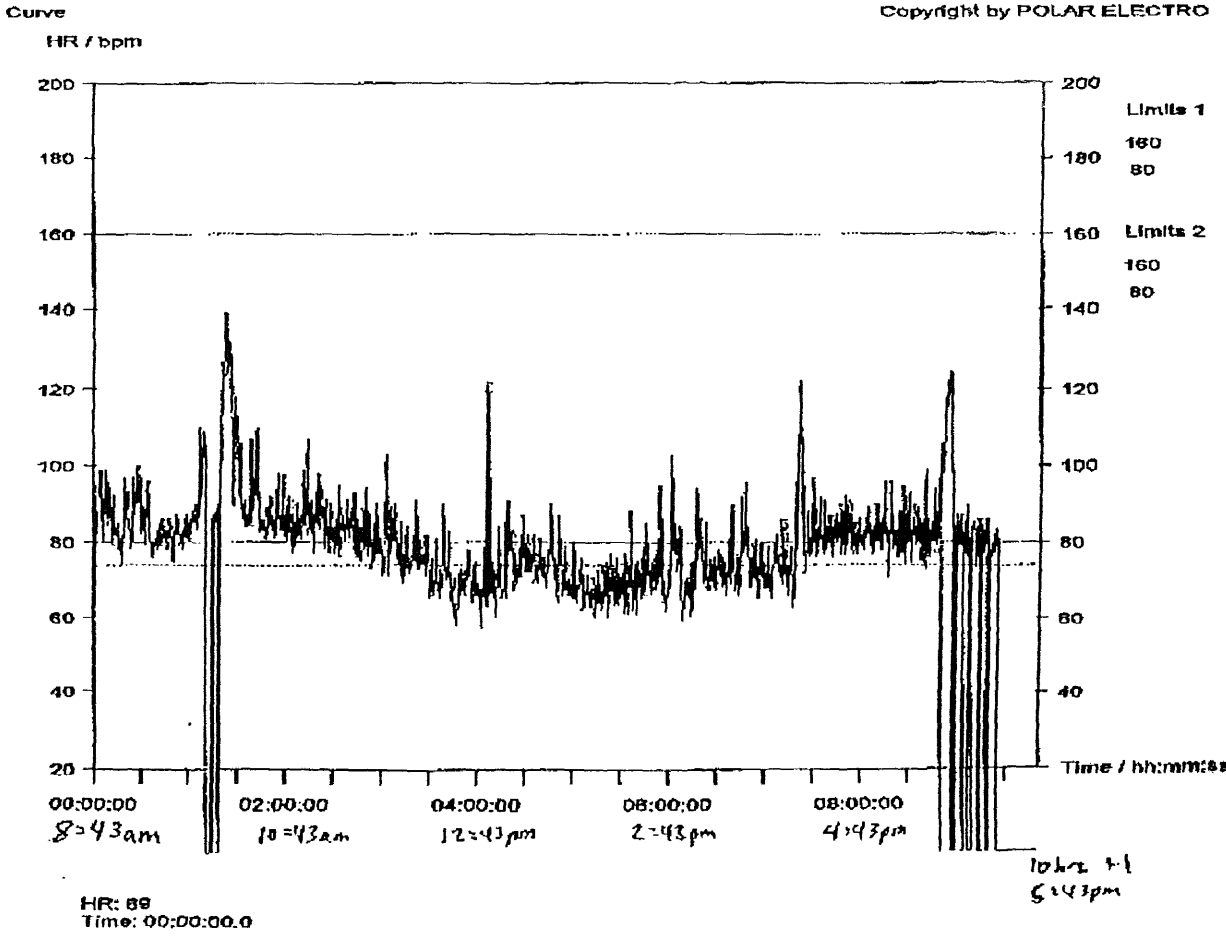

Person	Joe Average	Date	01/03/1998	Average	74 bpm	Recovery	0
Exercise	1999/03/01 08:43:10	Time	8:43:10	Duration of exercise: 09:50:10.4			
Note	31/01						

Figure C.1 Circadian Rhythm morning #1 raw heart rate data

APPENDIX C
(Continued)

Copyright by POLAR ELECTRO

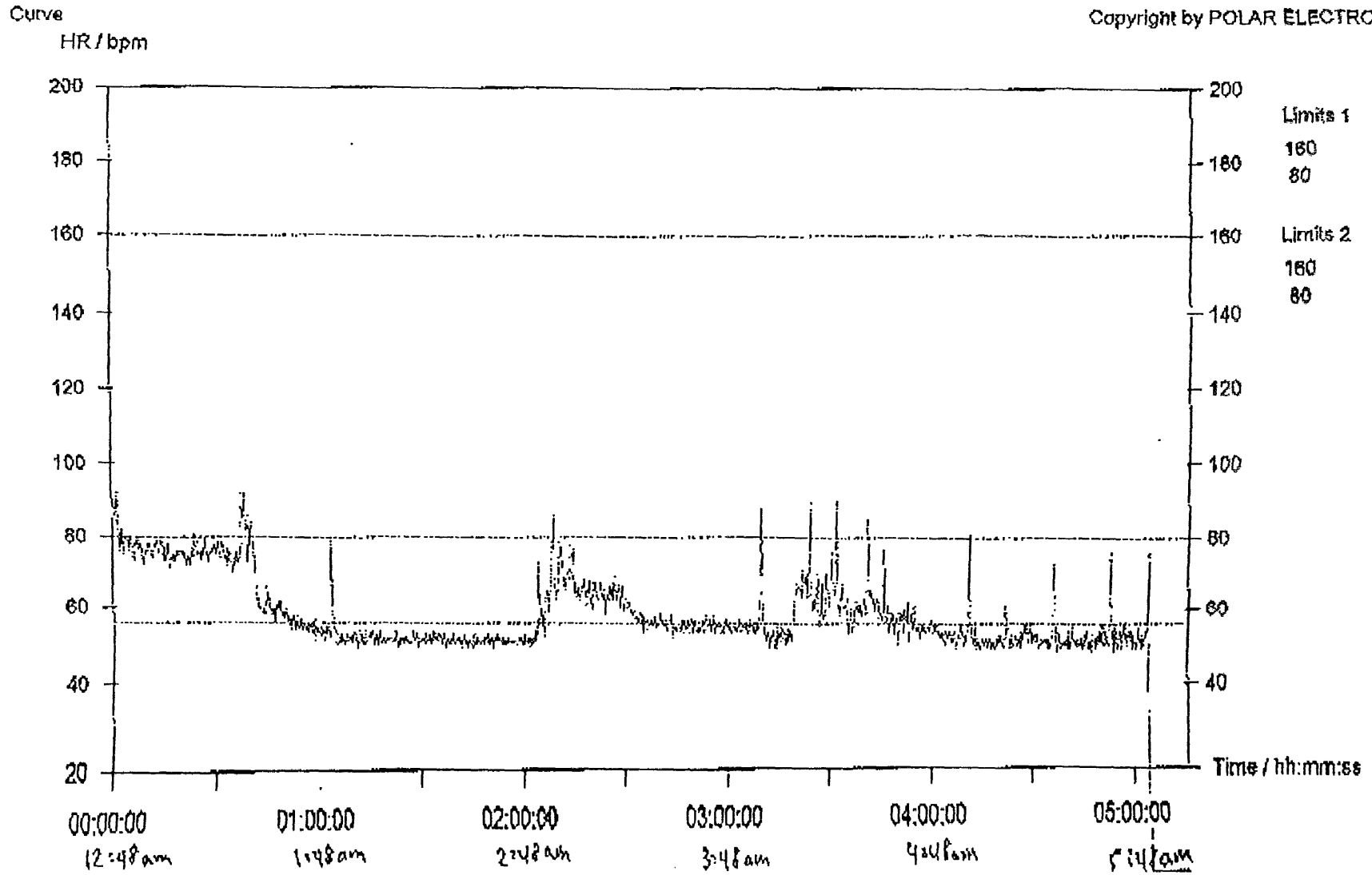

Figure C.2 Morning #2 raw heart rate data

APPENDIX C
(Continued)

Copyright by POLAR ELECTRO

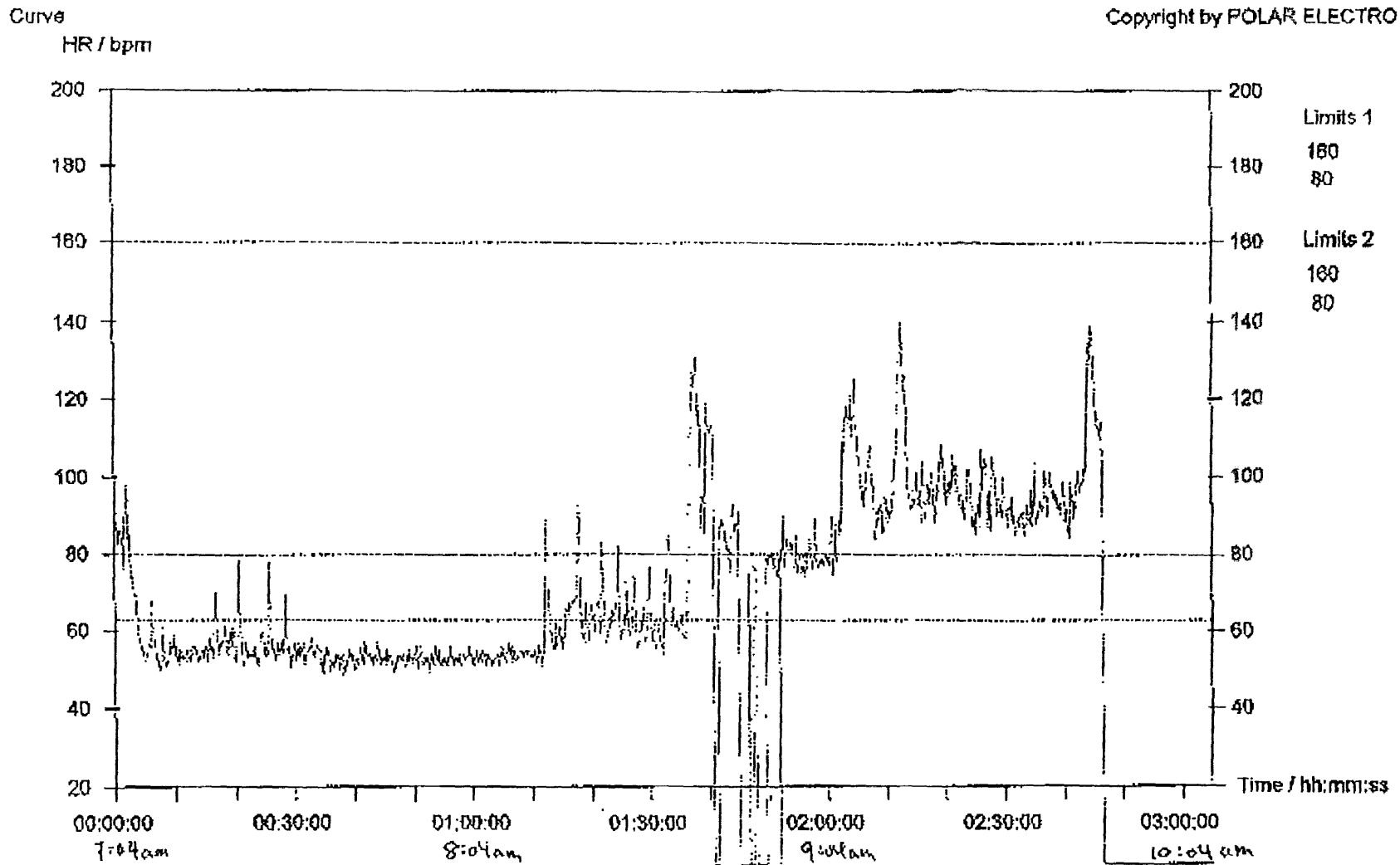

Figure C.3 Morning #2 continued

APPENDIX C
(Continued)

Copyright by POLAR ELECTRO

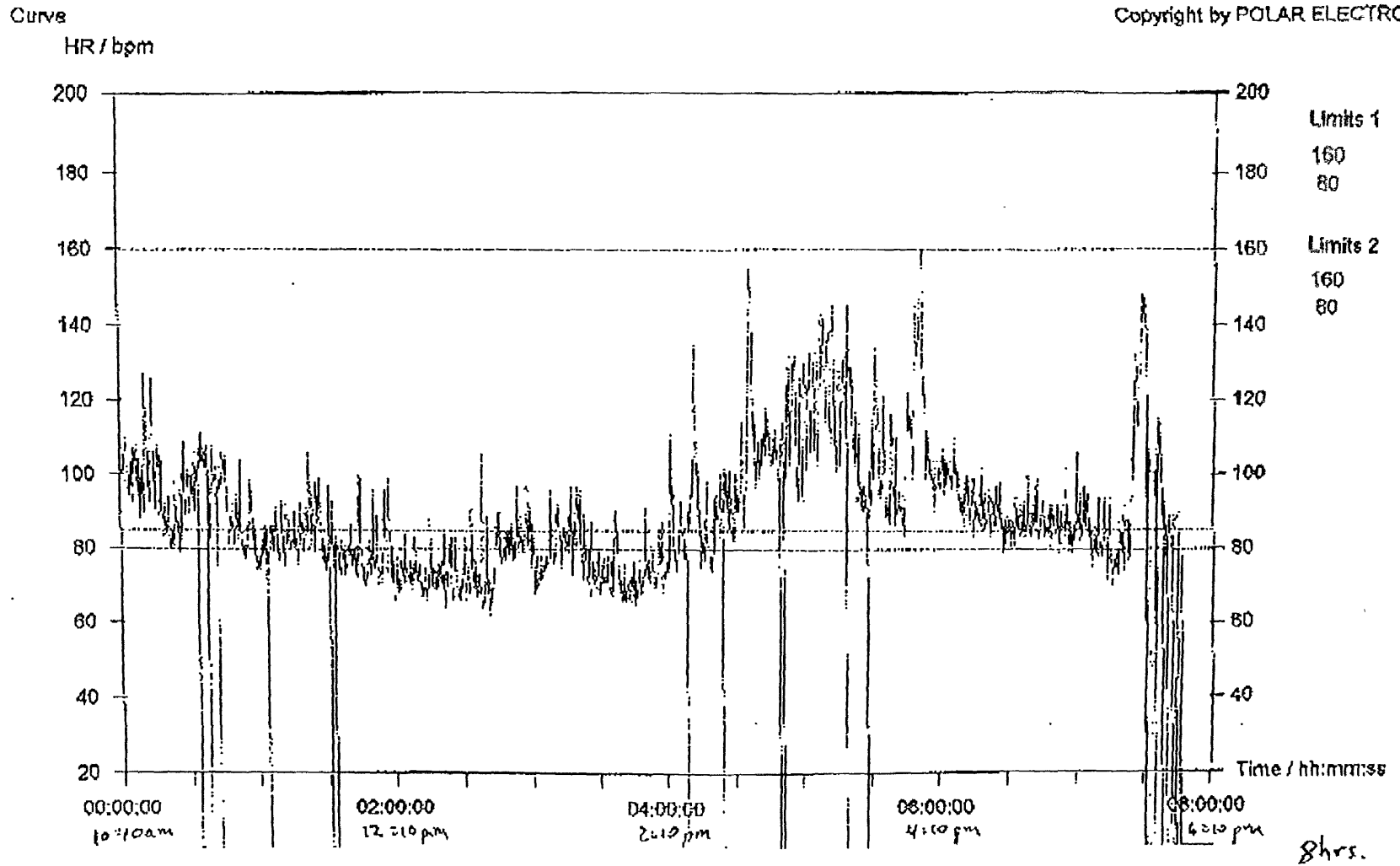

Figure C.4 Day #2 raw heart rate data

APPENDIX C
(Continued)

Curve

Copyright by POLAR ELECTRO

HR / bpm

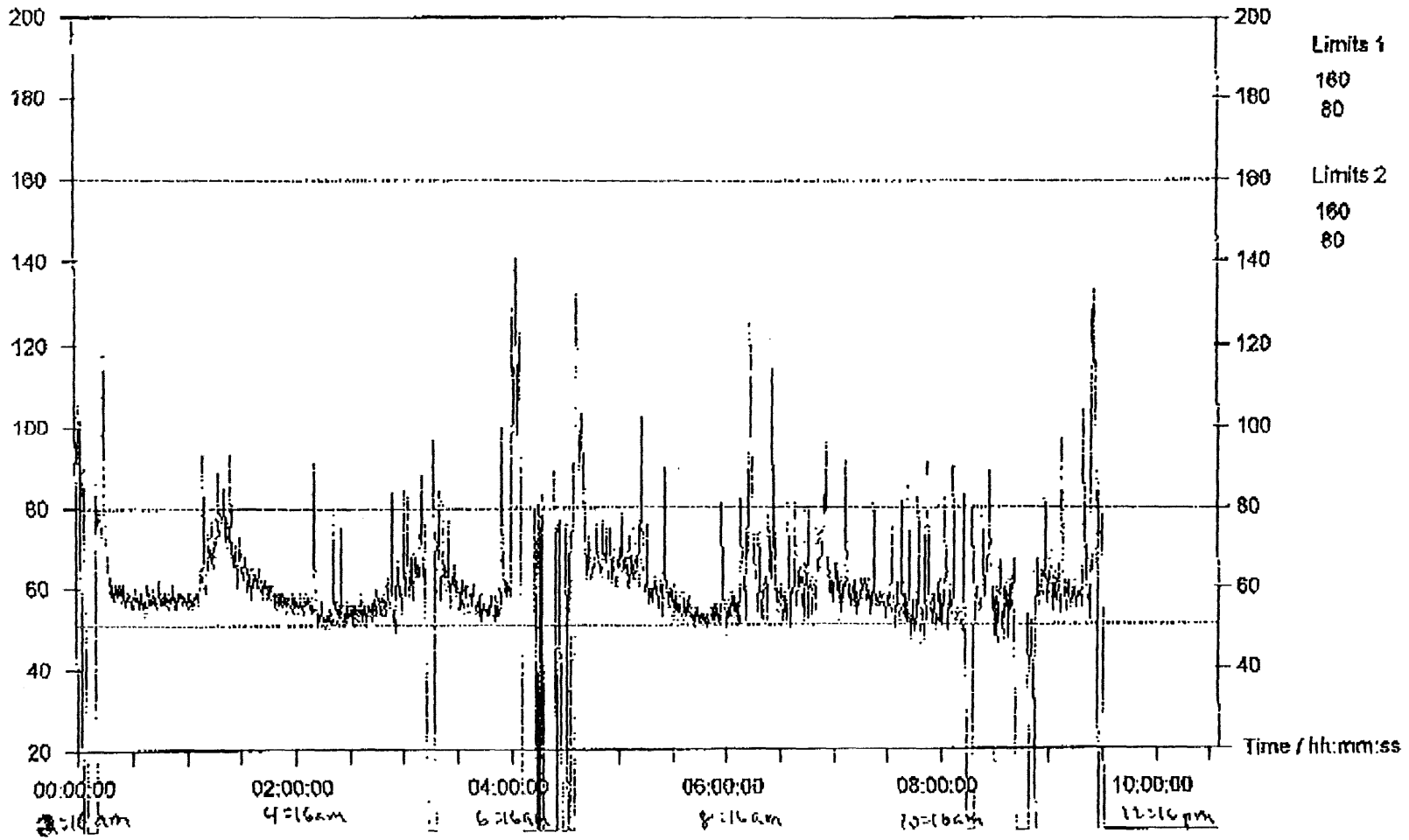

Figure C.5 Morning #3 raw heart rate data

APPENDIX C
(Continued)

Curve
HR / bpm

Copyright by POLAR ELECTRO

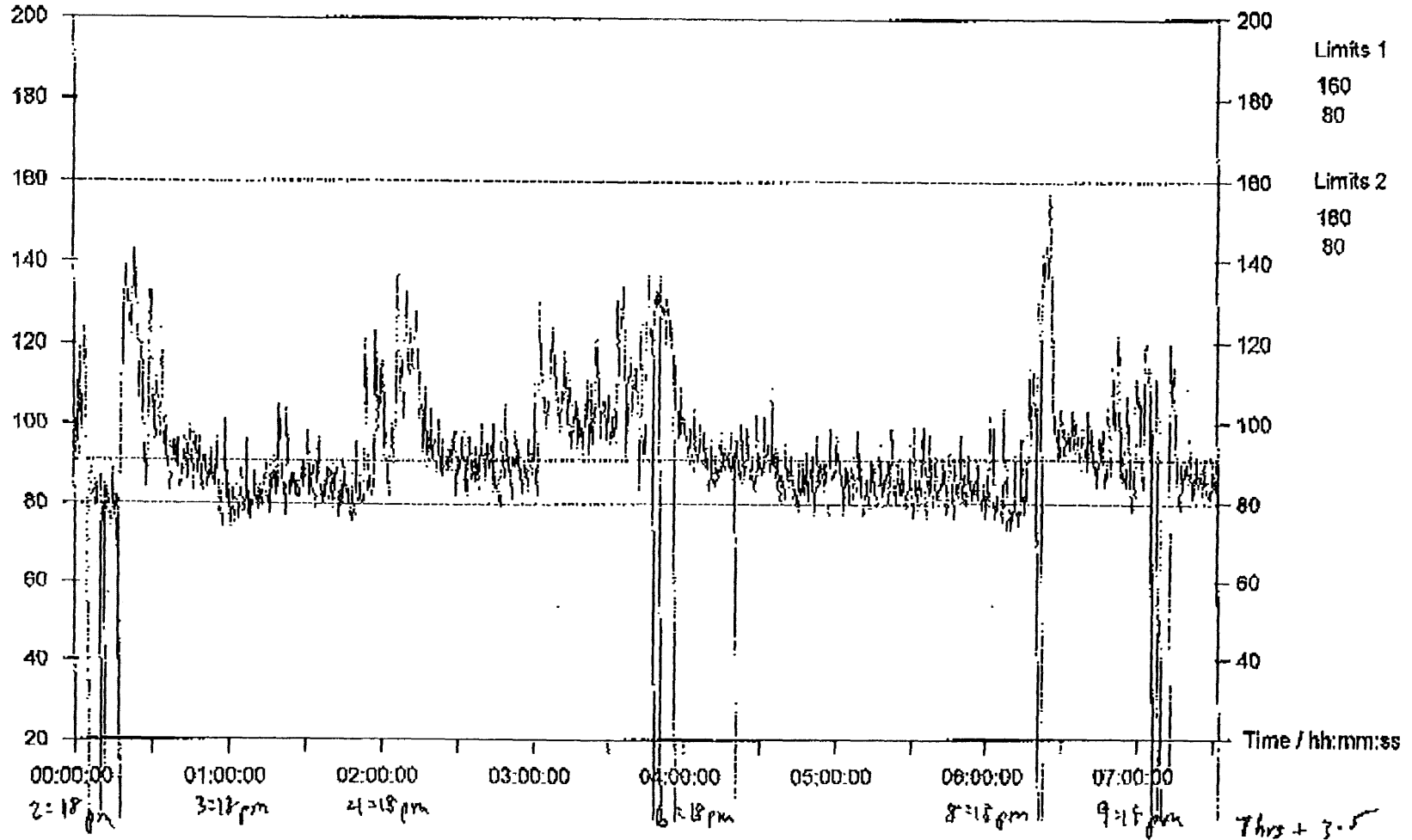

Figure C.6 Morning #3 continued

APPENDIX C
(Continued)

Copyright by POLAR ELECTRO

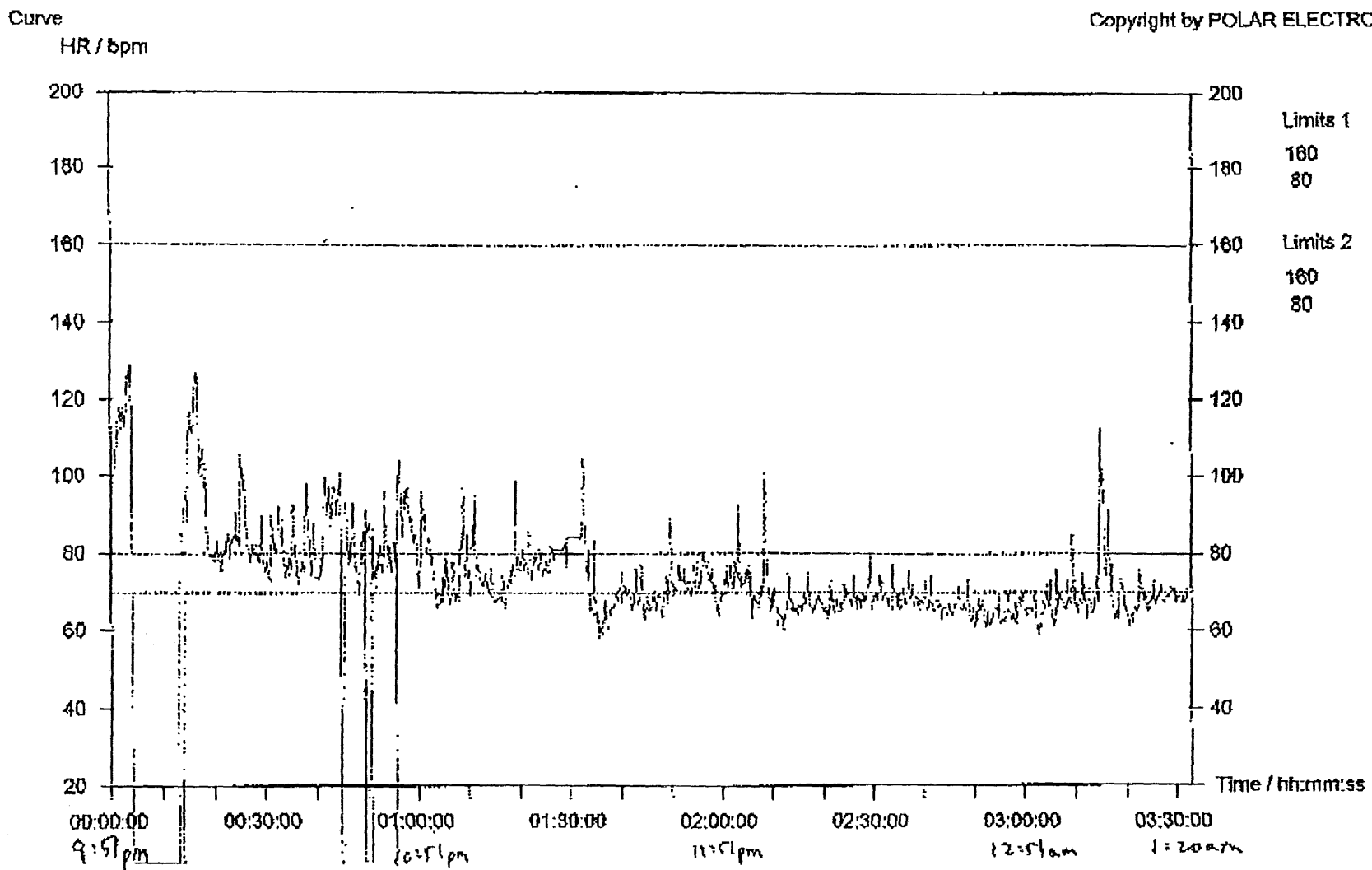

Figure C.7 Day #3 raw heart rate data

APPENDIX C
(Continued)

Copyright by POLAR ELECTRO

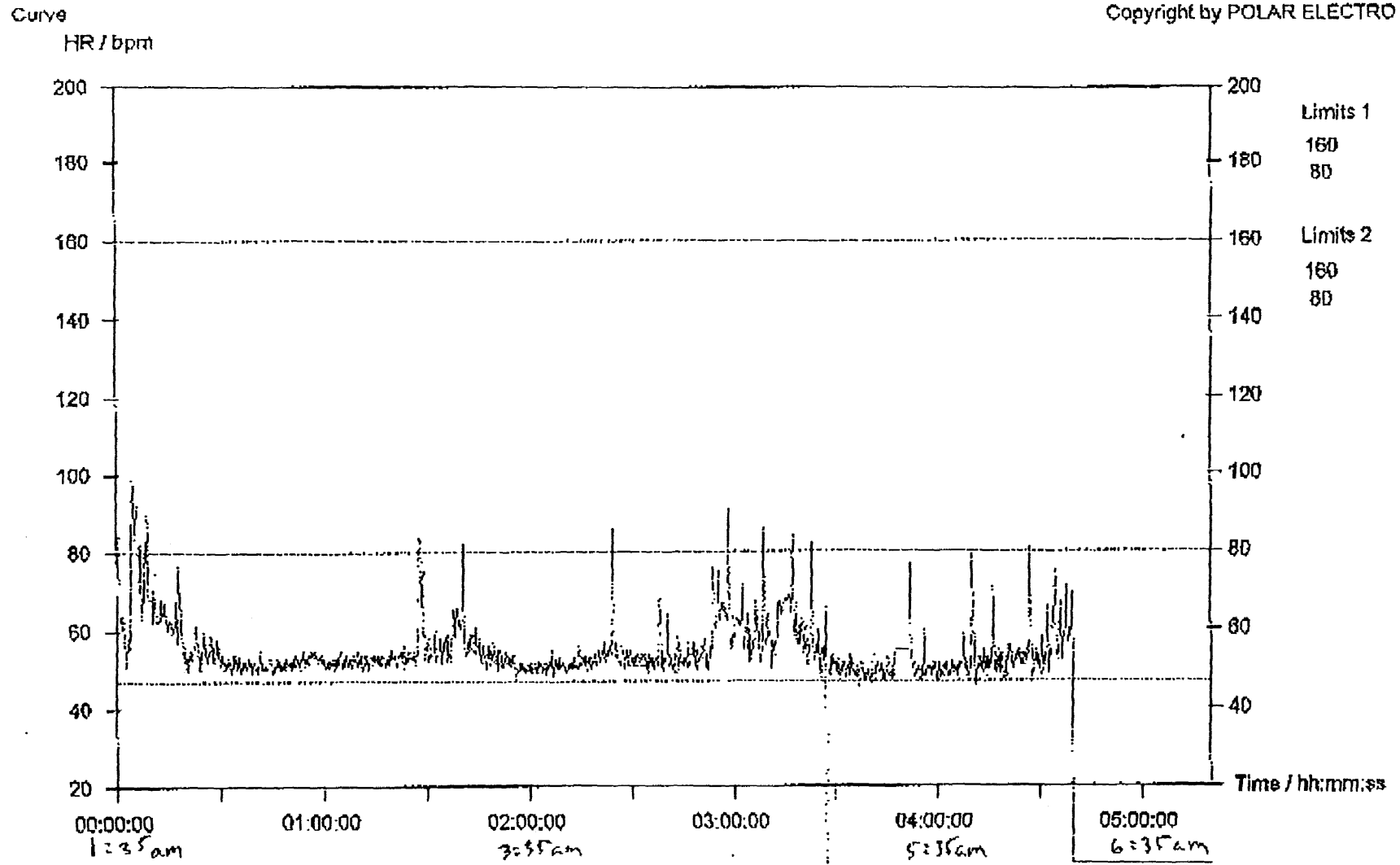

Figure C.8 Morning #4 raw heart rate data

APPENDIX C
(Continued)

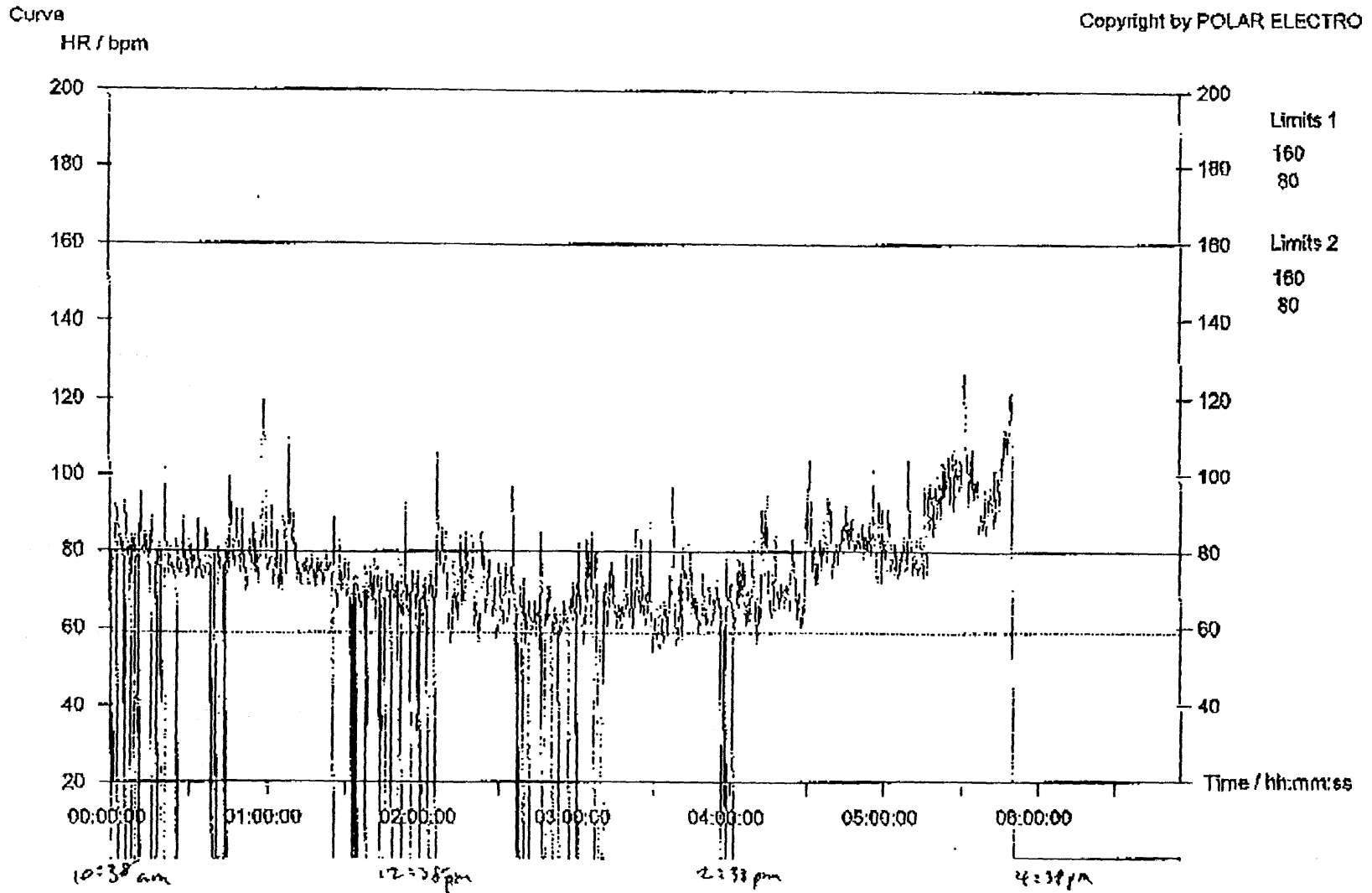

Figure C.9 Morning #4 continued

APPENDIX C
(Continued)

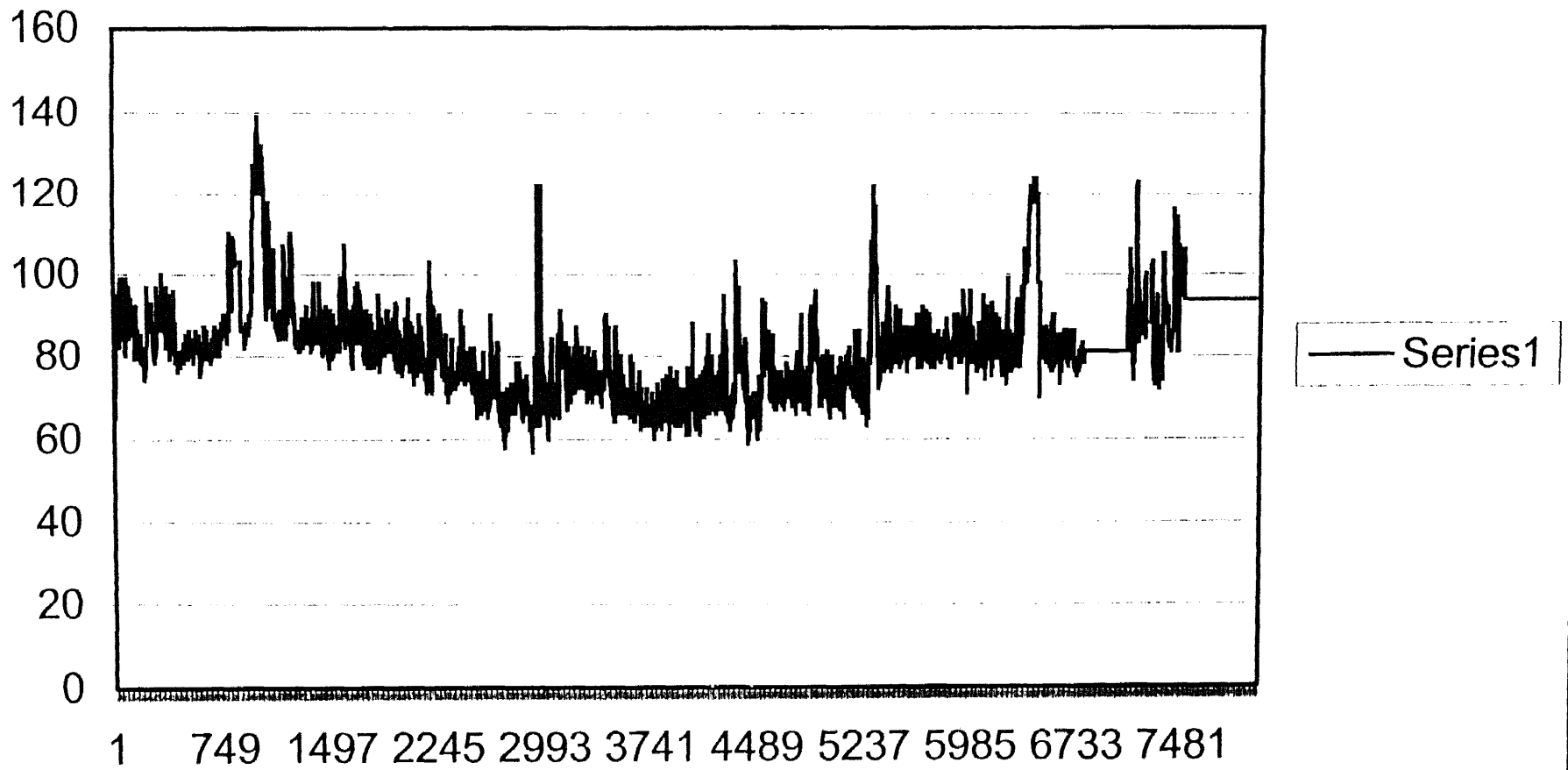

Figure C.10 Circadian rhythm morning #1 cleaned non-zero heart rate data

APPENDIX D

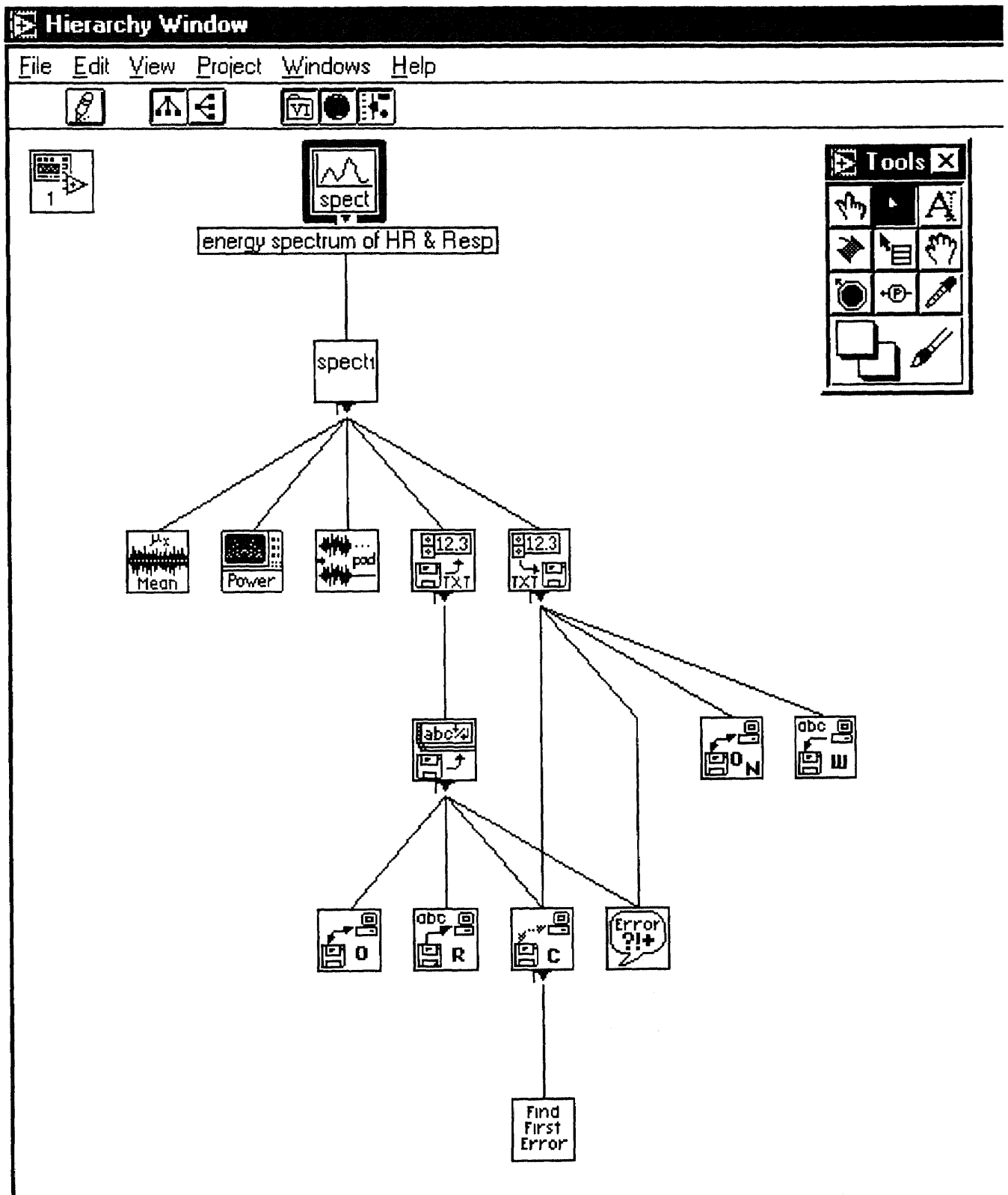

Figure D.1 LabVIEW program hierarchy window

APPENDIX D
(Continued)

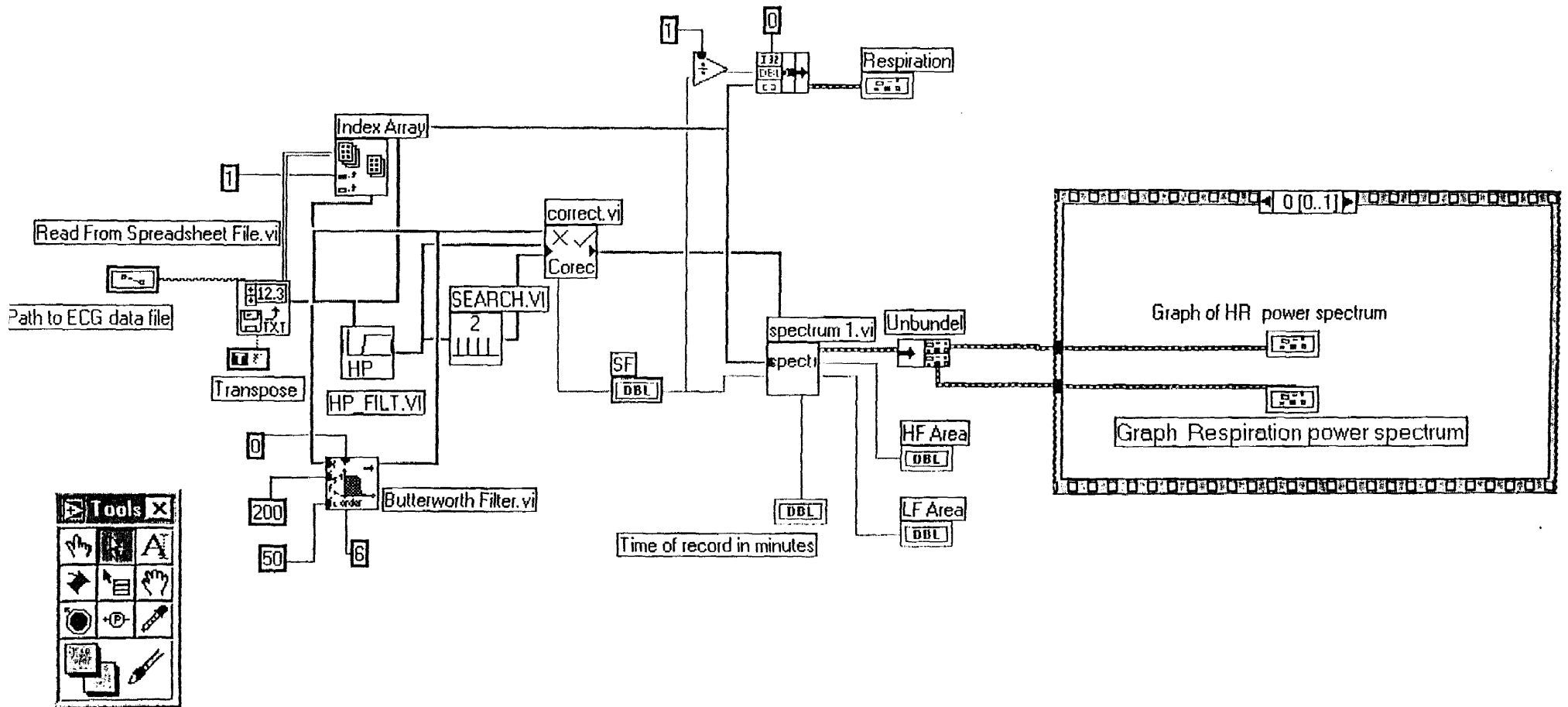

Figure D.2 The Heart Rate & Respiration Power Spectrum program in Labview

APPENDIX D
(Continued)

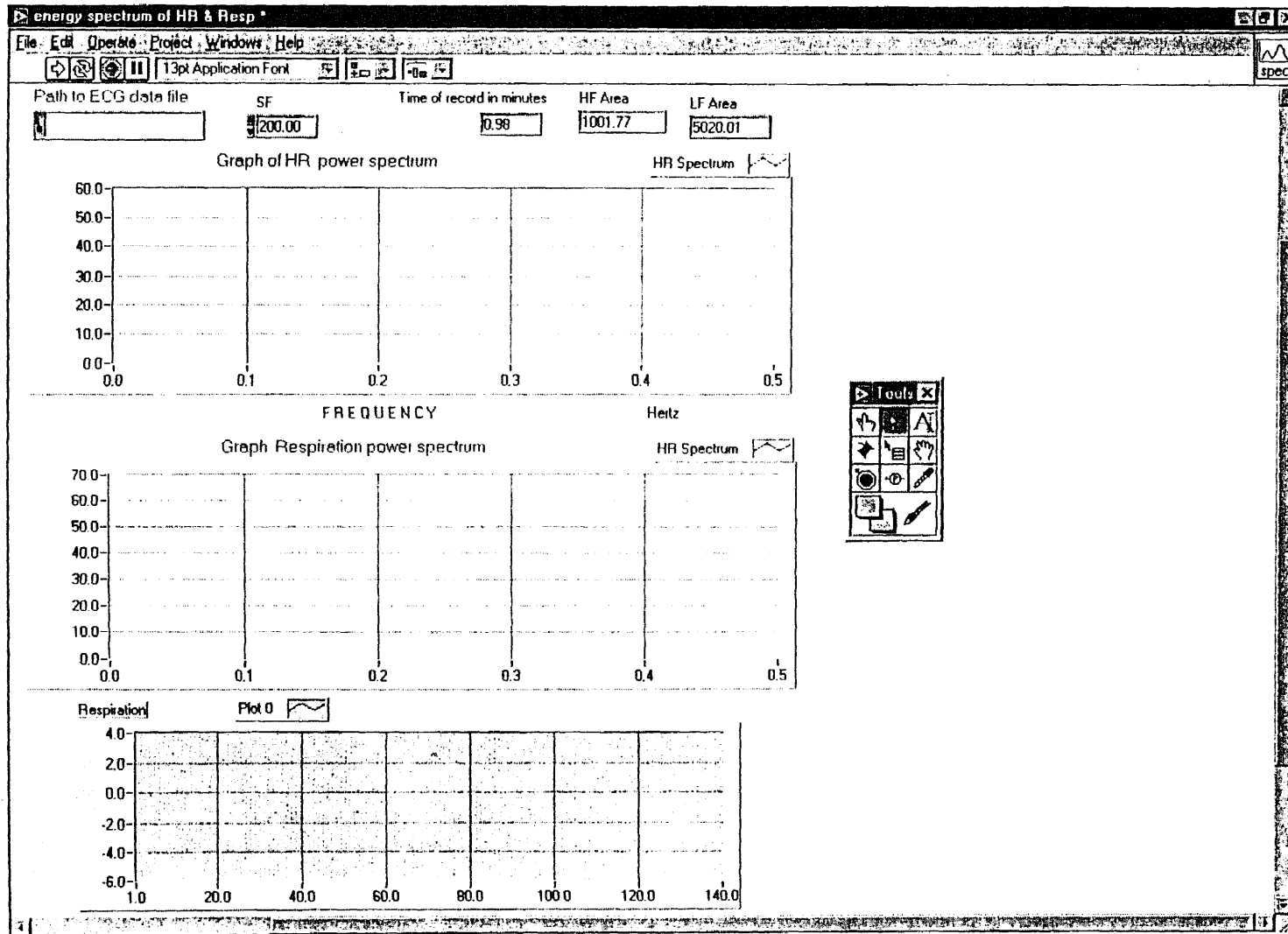

Figure D.3 The front panel of the program

APPENDIX D
(Continued)

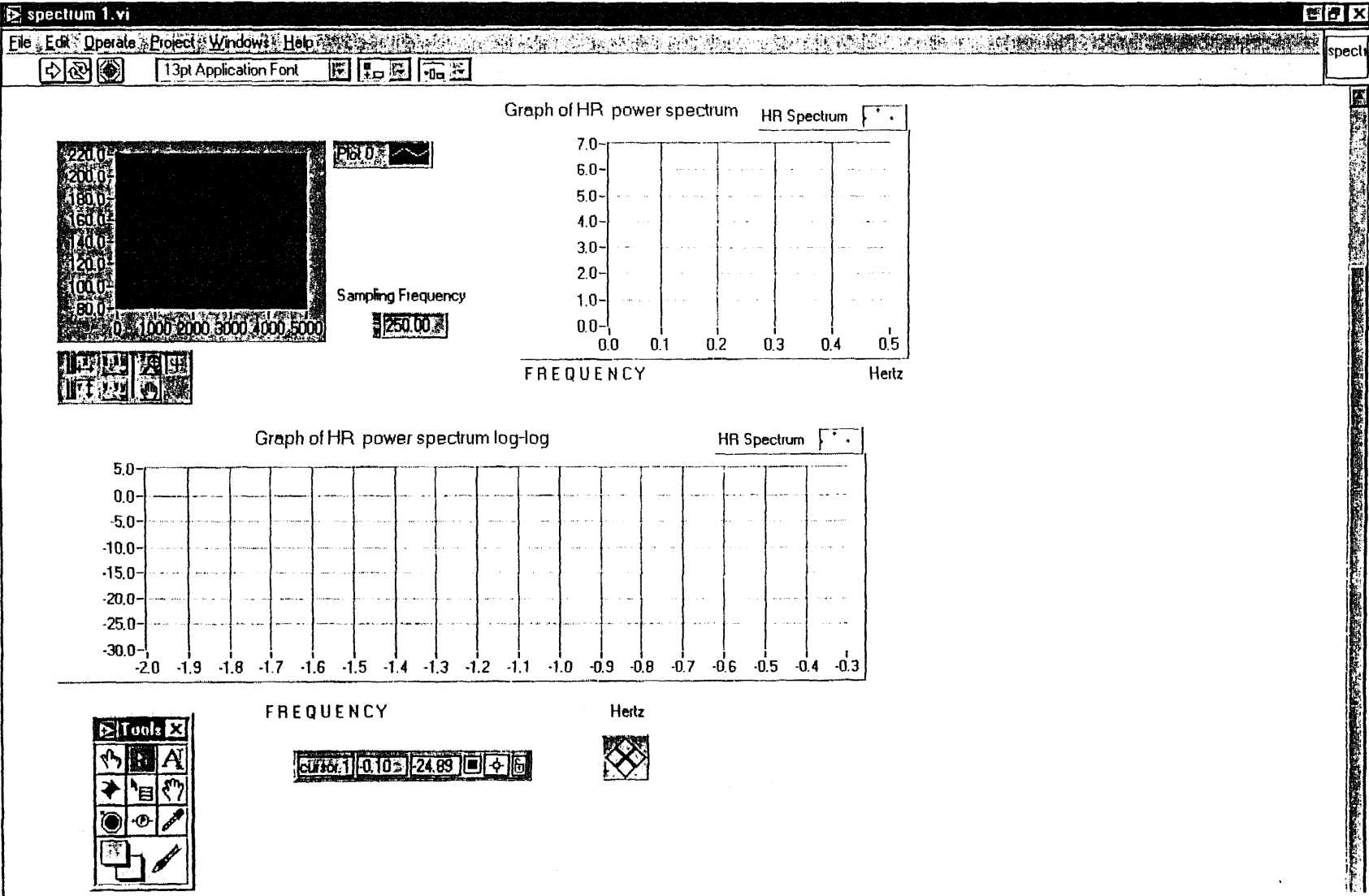

Figure D.5 Modified front panel of program

APPENDIX D
(Continued)

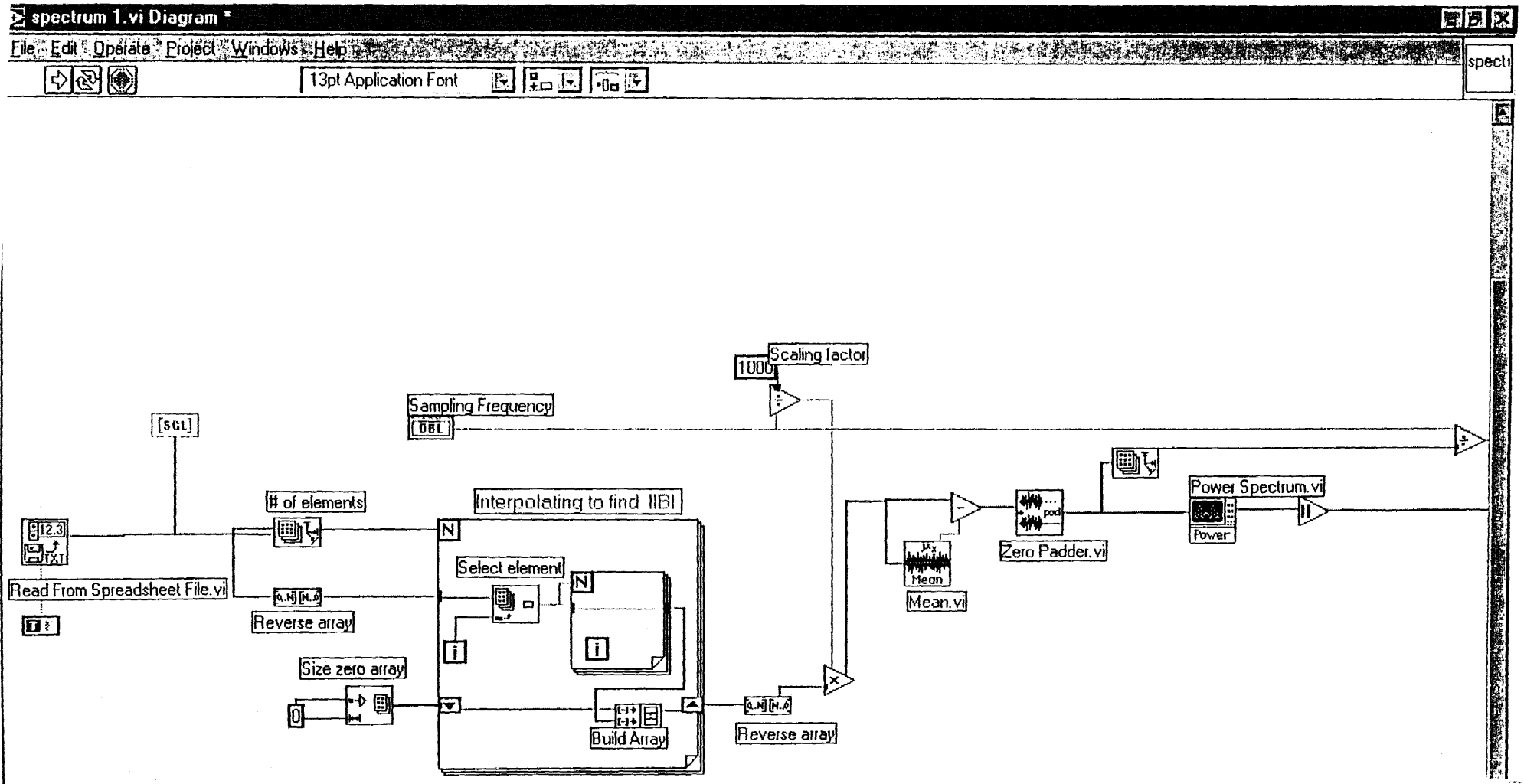

Figure D.6 Modified program showing left side of diagram

APPENDIX D
(Continued)

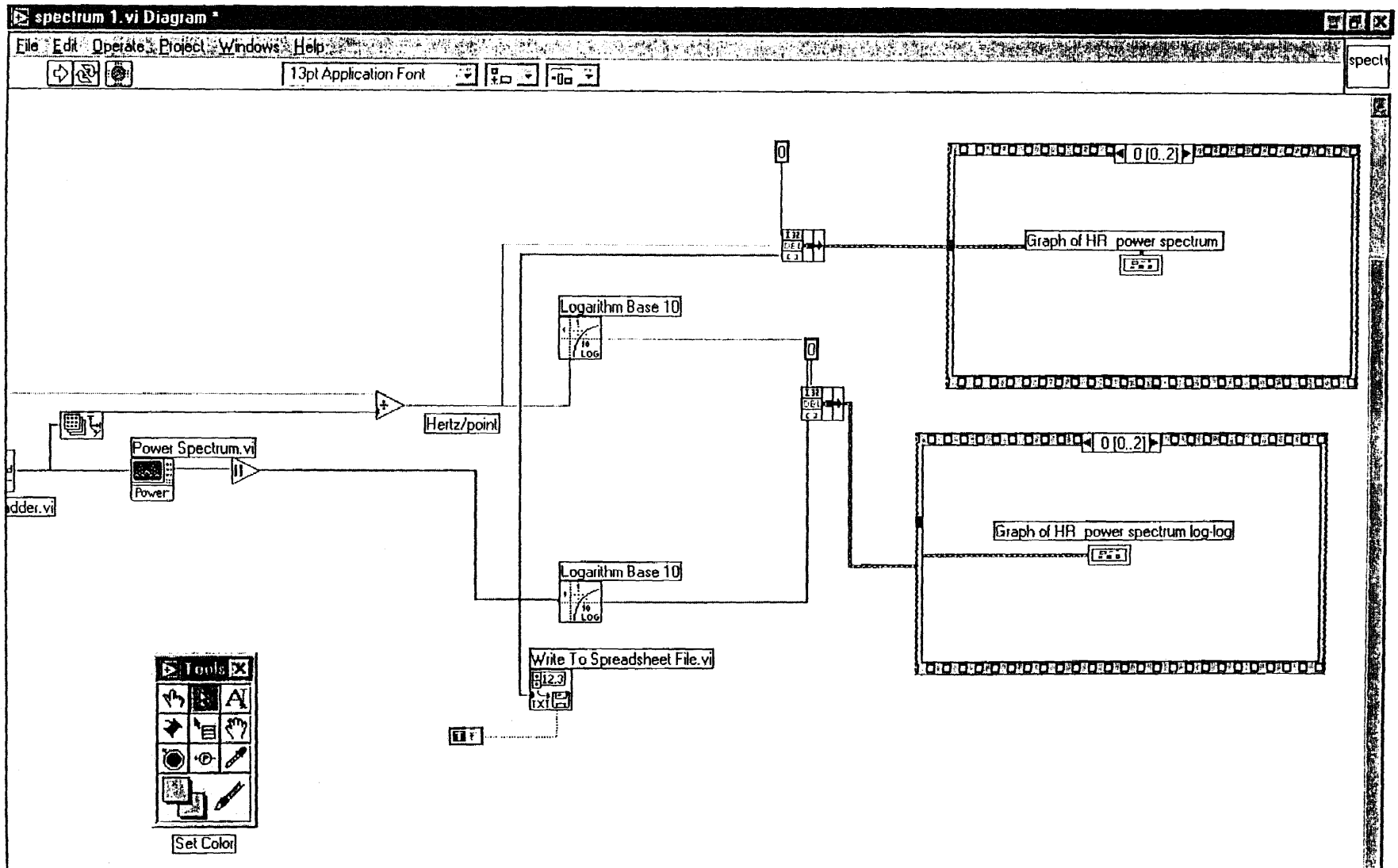

Figure D.7 Modified program showing right side of diagram

APPENDIX E

Table E.1 1/f results in RR watch setting

R-R Data File	Regression Line	R ²
RR1	$Y = -0.35X - 1.8$	$R^2 = 0.03$
RR2	$Y = -1.17X - 2.0$	$R^2 = 0.42$
RR3	$Y = -1.58X - 1.30$	$R^2 = 0.57$

Table E.2 1/f results in 5sec watch setting

5sec Data File	Regression Line	R ²
5sec1	$Y = -1.99X - 1.87$	$R^2 = 0.69$
5sec2	$Y = -1.87X - 1.95$	$R^2 = 0.65$
5sec3	$Y = -1.94X - 1.96$	$R^2 = 0.67$

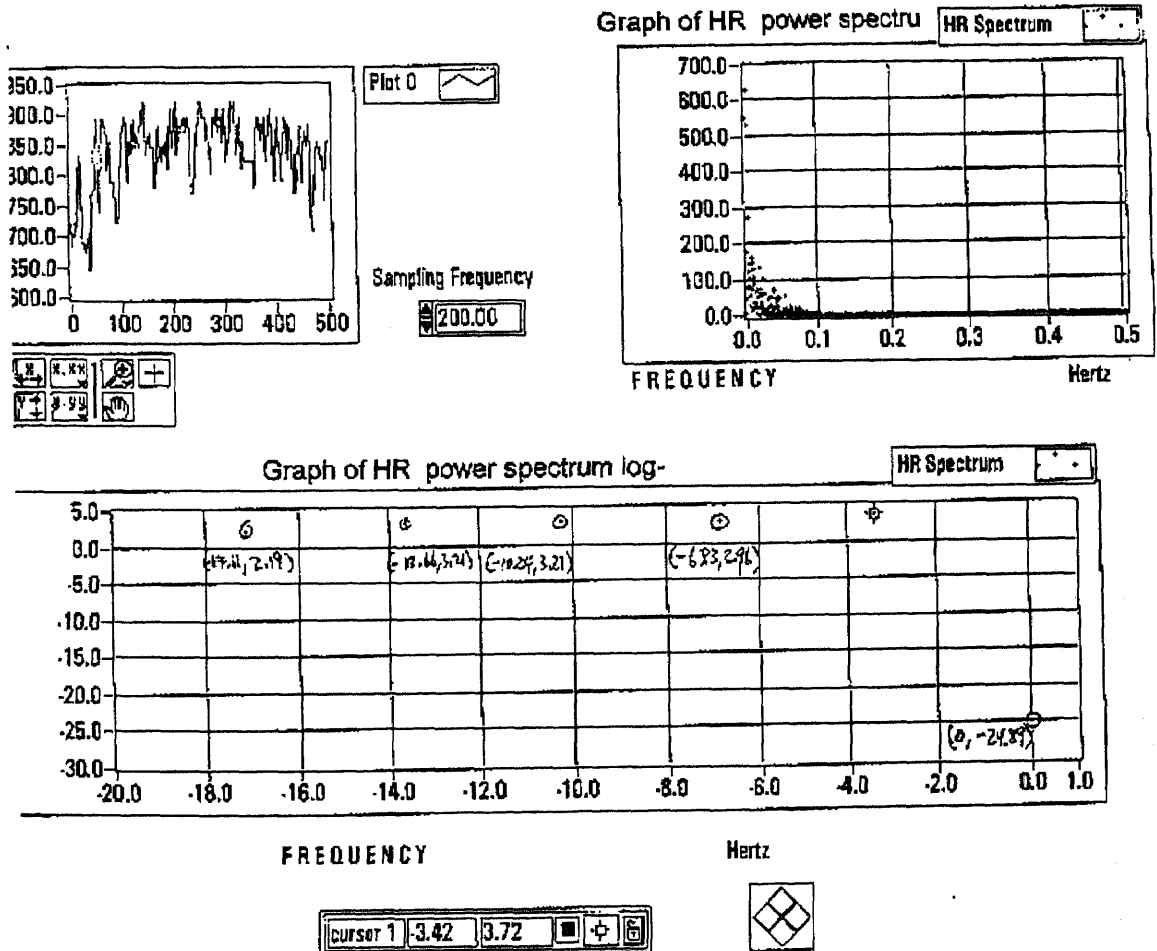

Figure E.1 file 5sec_1.

APPENDIX E
(Continued)

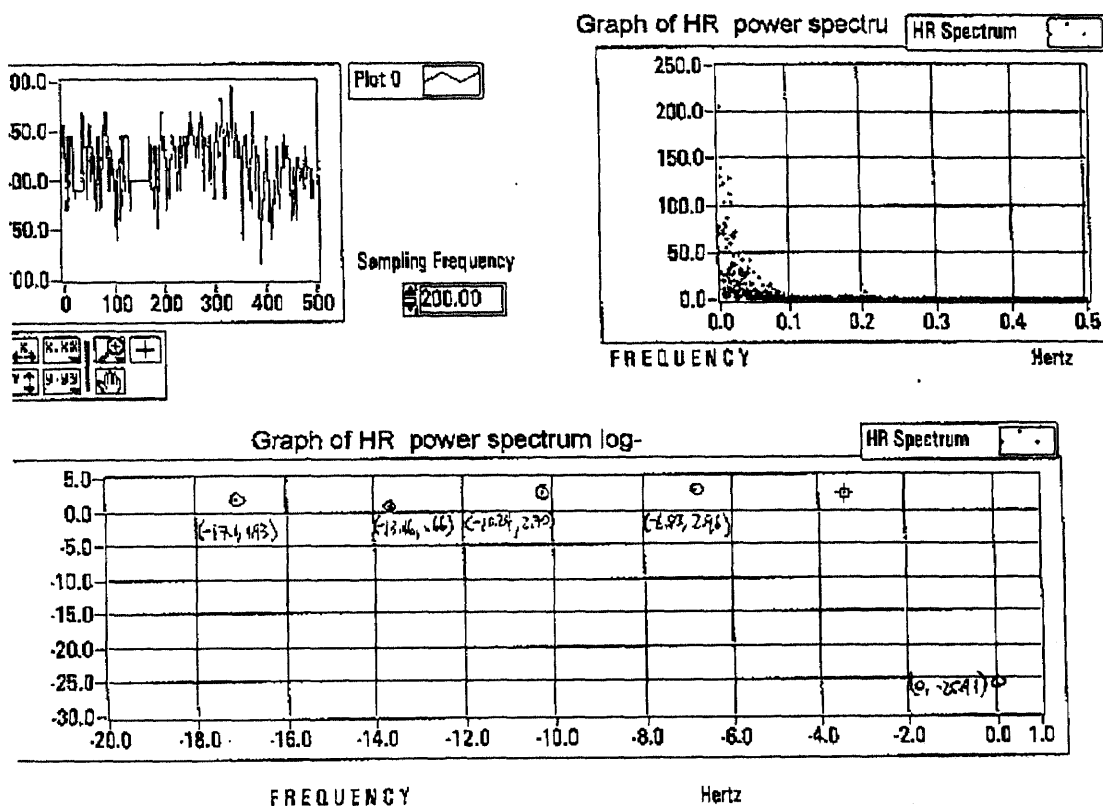

Figure E.2 file 5sec_2

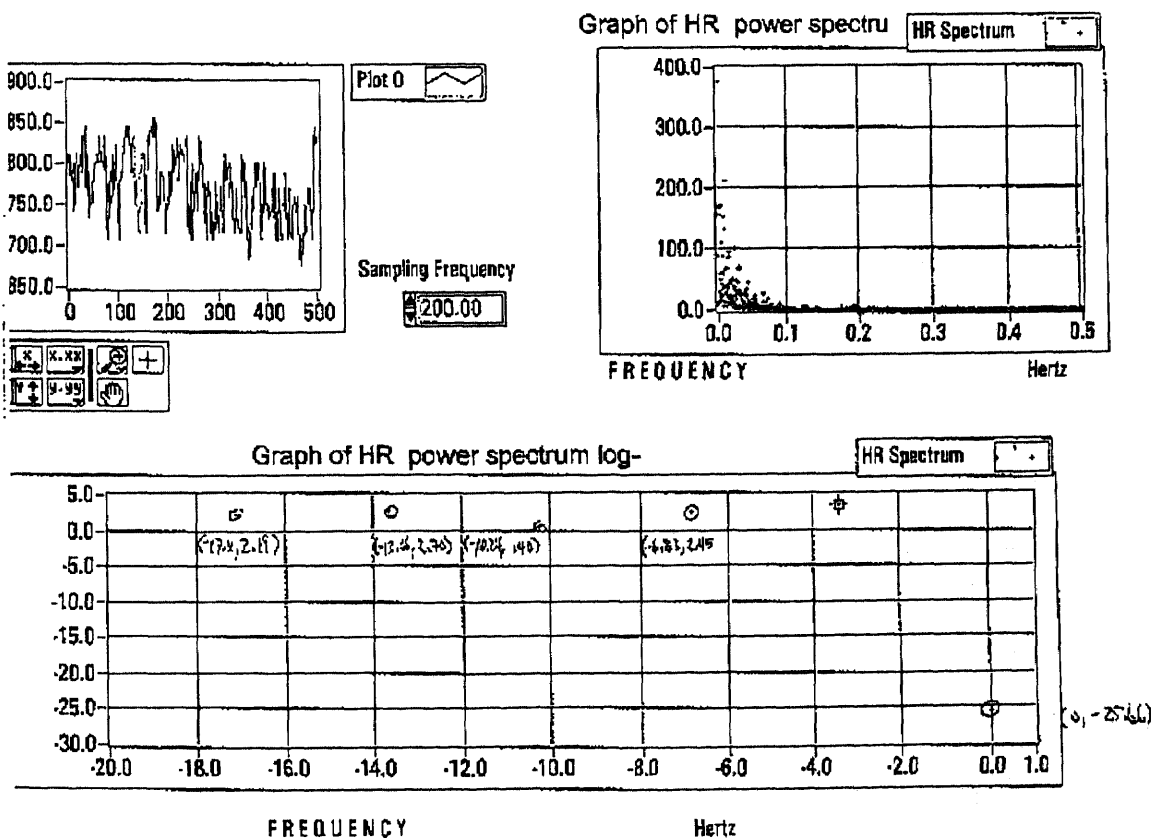

Figure E.3 File 5sec 3

APPENDIX E
(Continued)

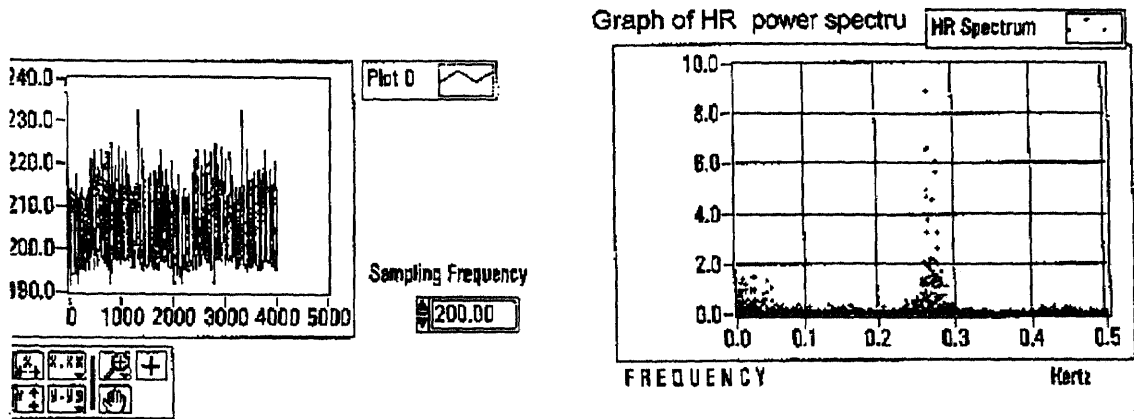

Figure E.4 File RR_1

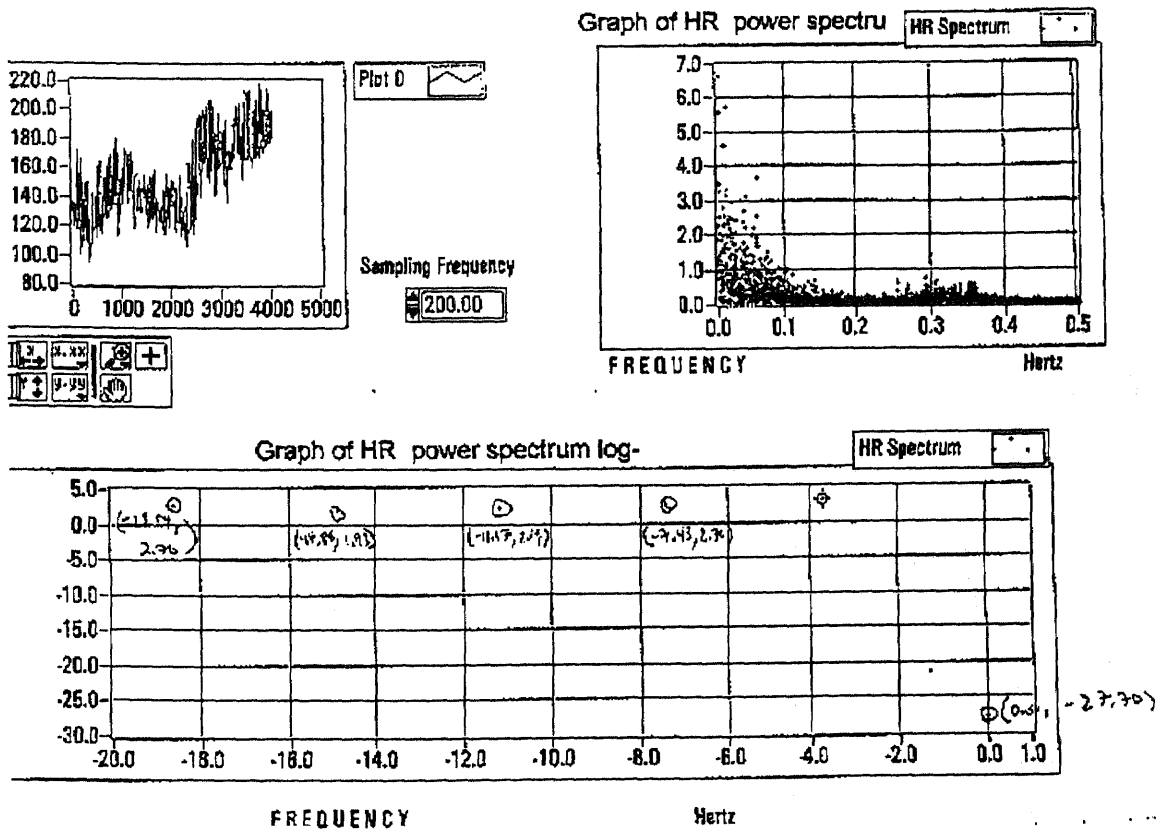

Figure E.5 File RR_2

APPENDIX E
(Continued)

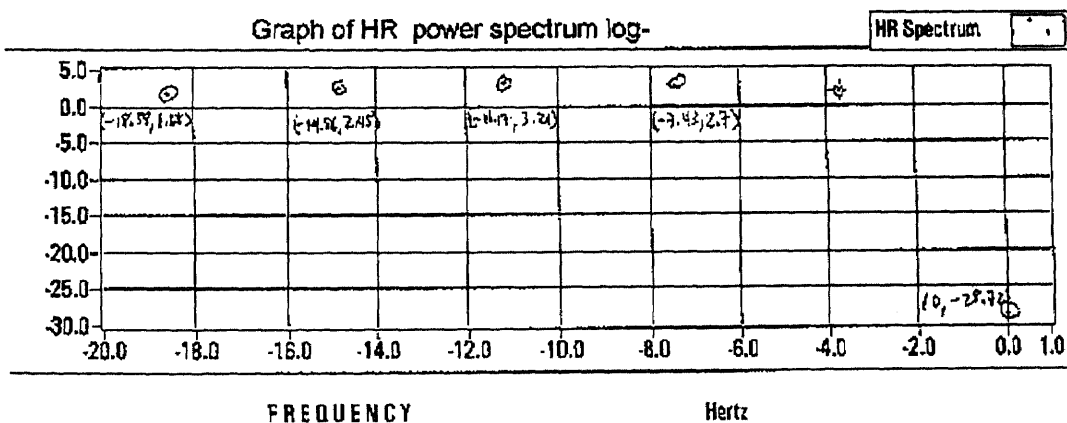
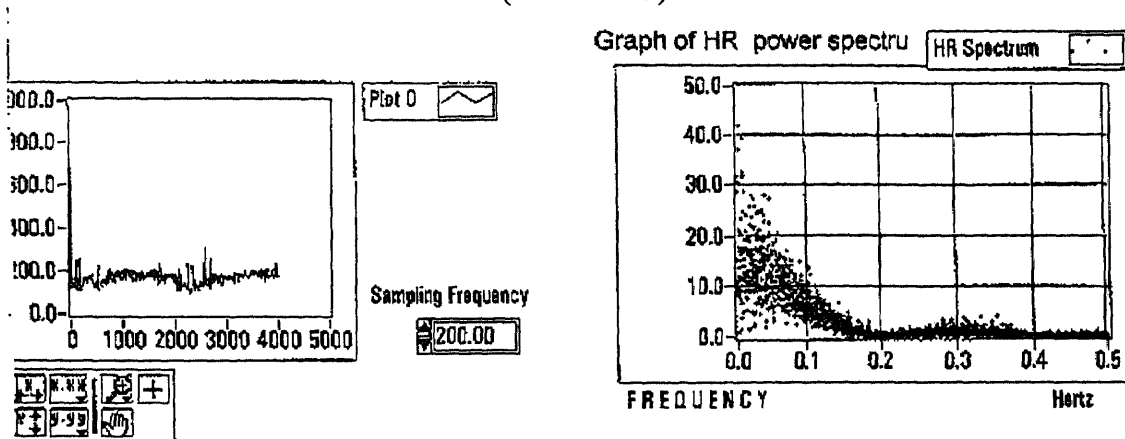

Figure E.6 File RR_3

6sec, 990201 morning-evening
3averaged

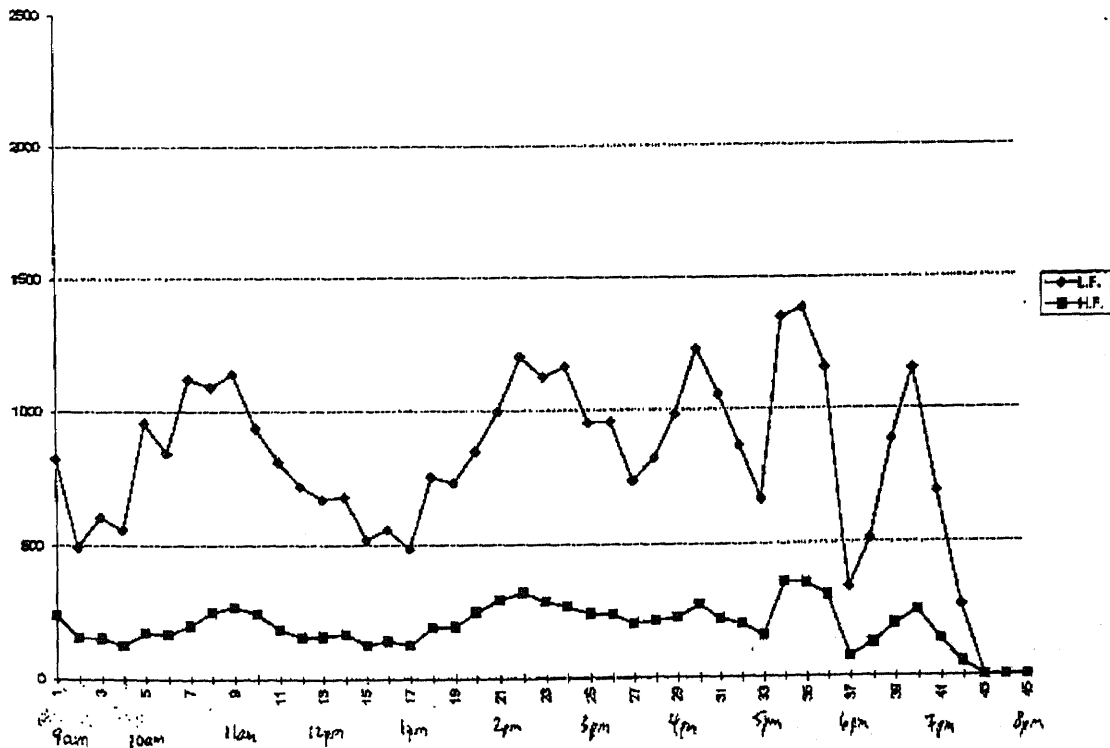

Figure E.7 Circadian rhythm morning #1. LF & HF vs. time

APPENDIX E
(Continued)

5sec,990302day-evening
3averaged

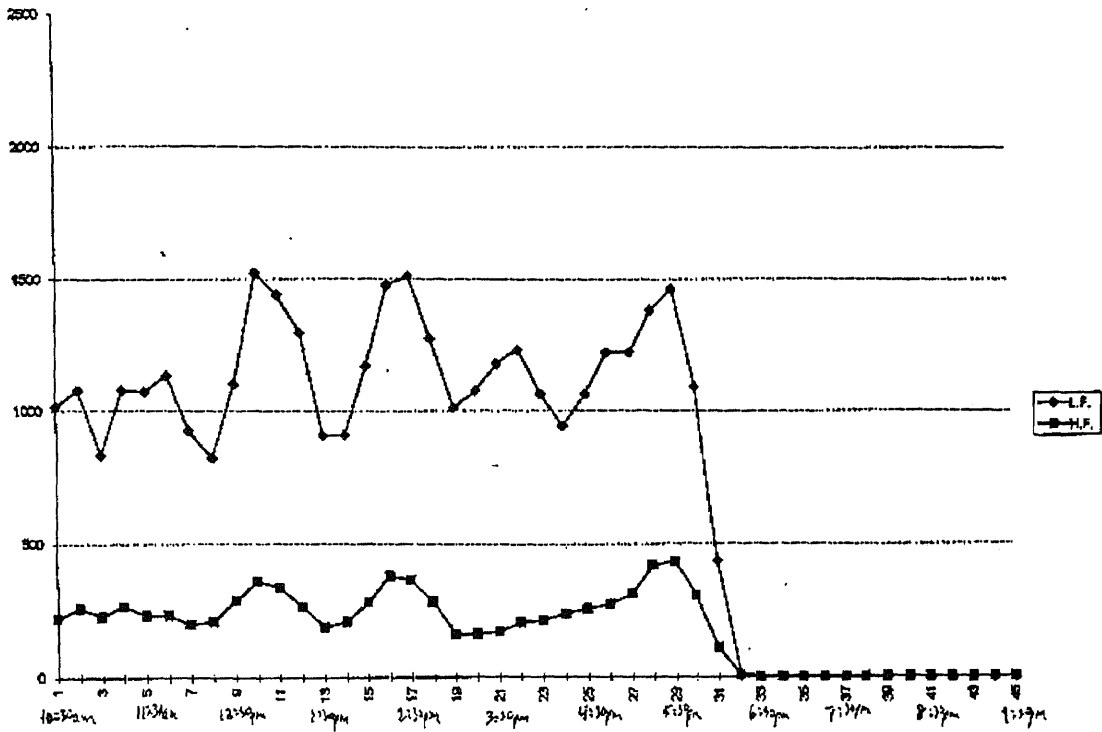

Figure E.8 Circadian rhythm day #2, LF & HF vs. time

5sec,990302sleep-morning
3averaged

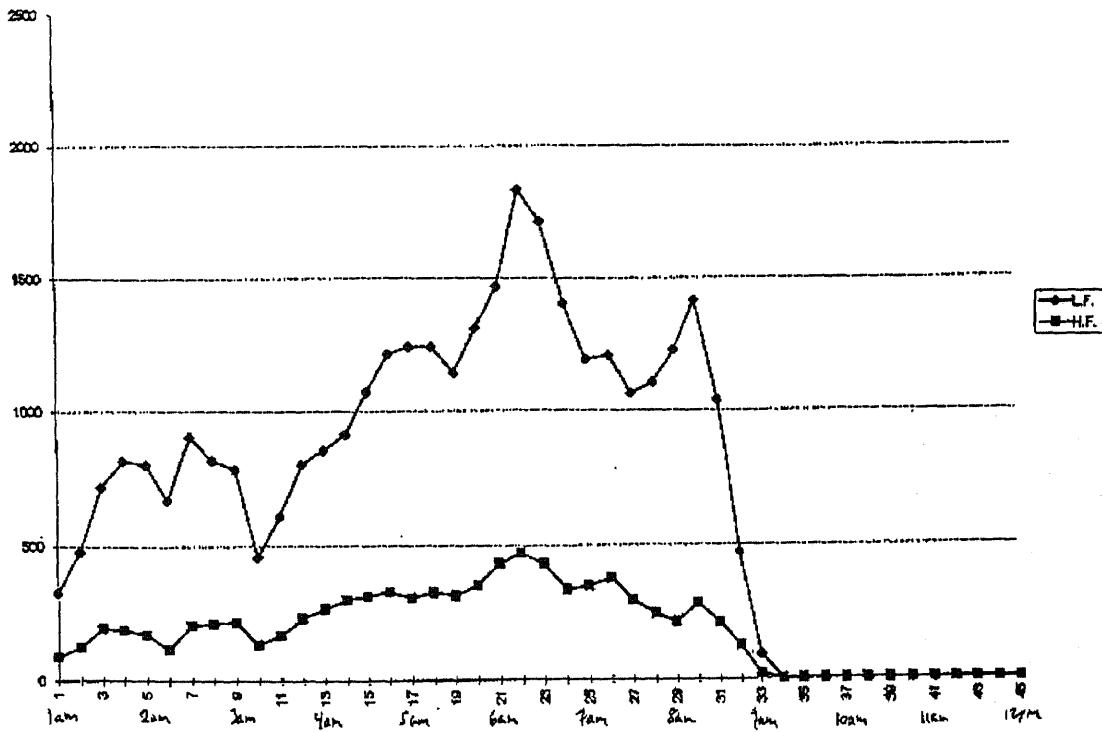

Figure E.9 Circadian rhythm morning #2, LF & HF vs. time

APPENDIX E
(Continued)

990303day-Savaaged

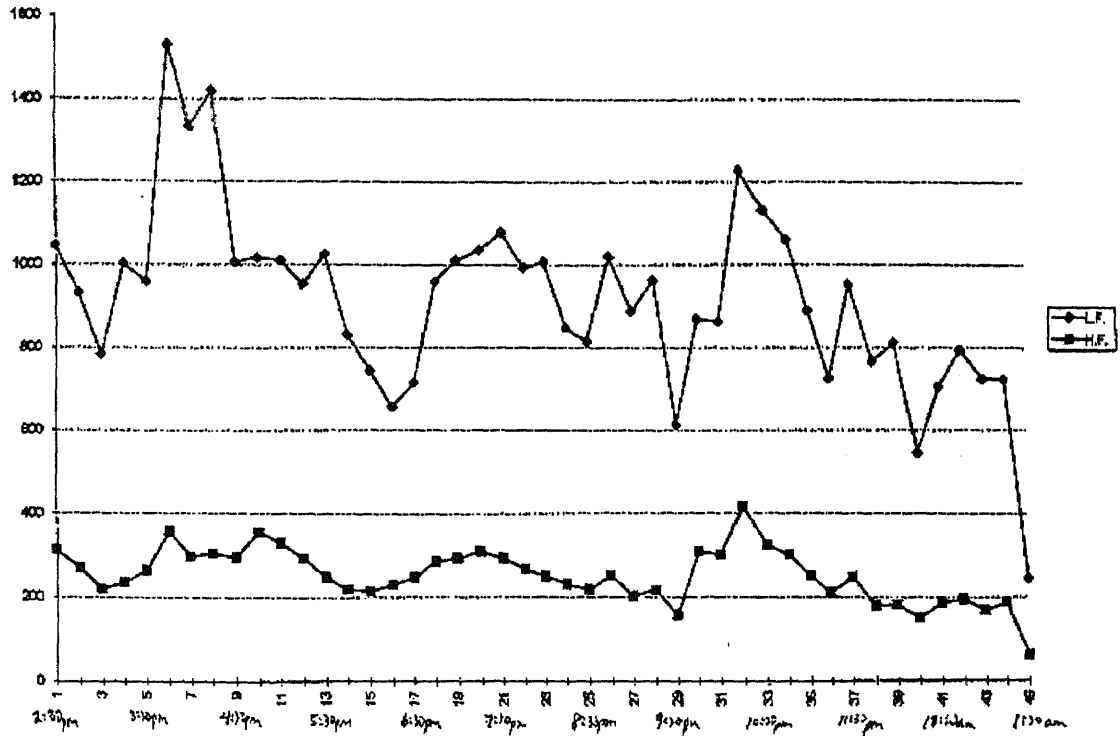

Figure E.10 Circadian rhythm evening #3, LF & HF vs. time

Sec,990303sleep-morning
Savaaged

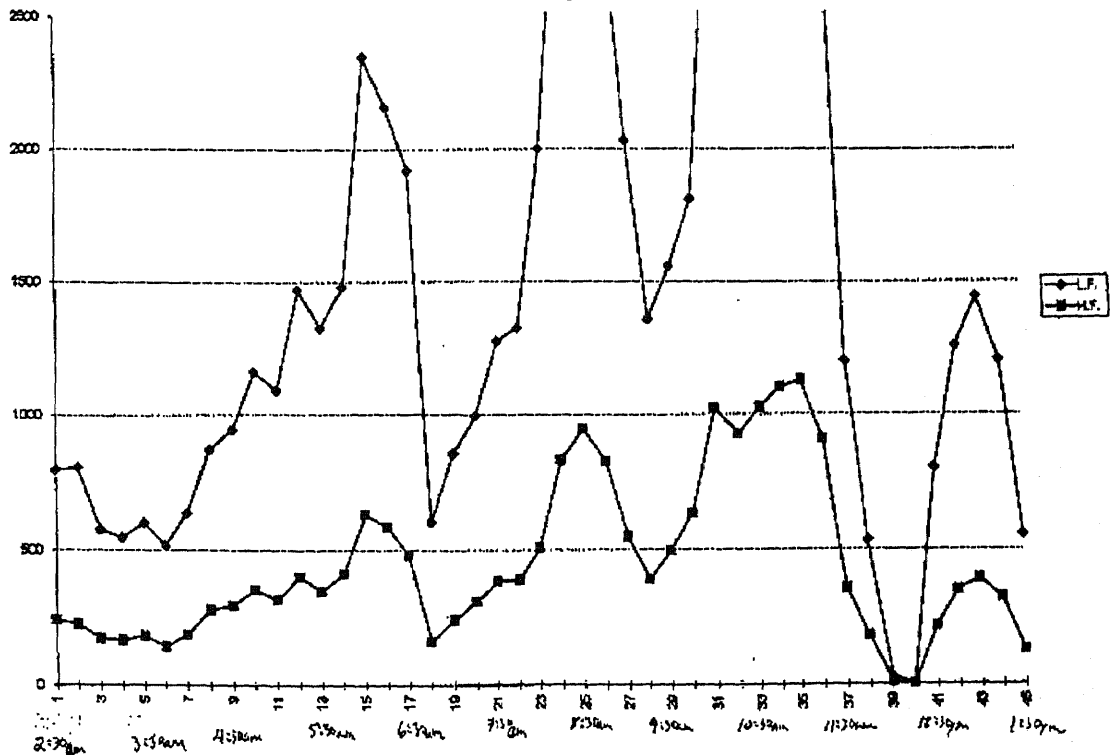

Figure E.11 Circadian rhythm morning #3, LF & HF vs. time

APPENDIX E
(Continued)

990304morning

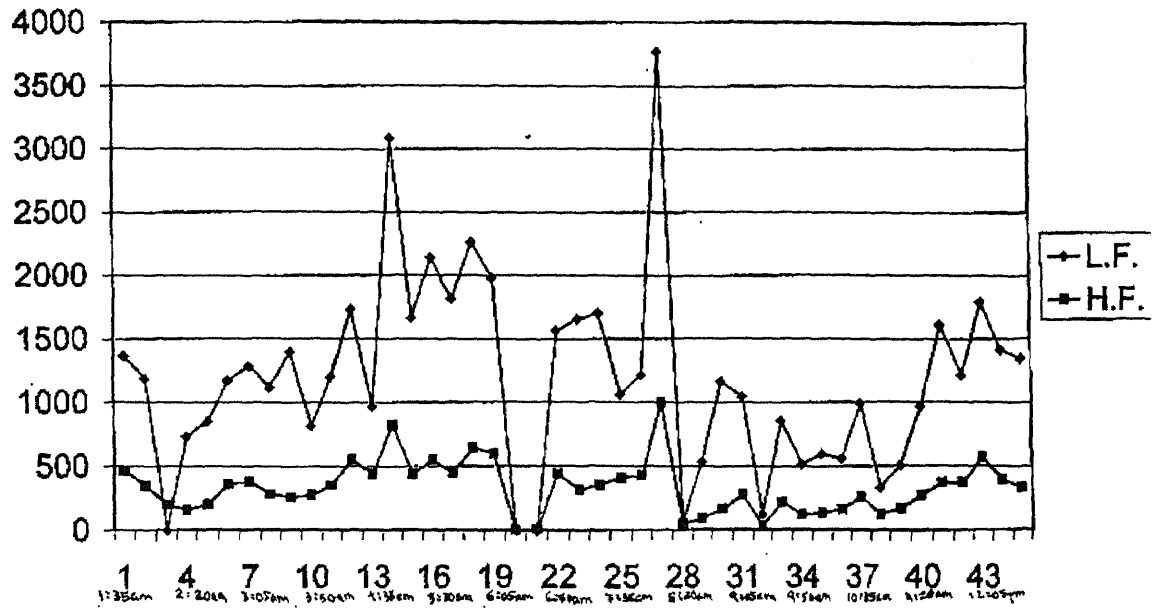

Figure E.12 Circadian rhythm morning #4, LF & HF vs. time

REFERENCES

1. J. G. Webster, *Medical Instrumentation: Application and Design 3rd Edition*, John Wiley & Sons, Inc. New York. pp.139-151, 273-281, 1998.
2. E. N. Marieb, *Human Anatomy and Physiology*, The Benjamin/Cummings Publishing Company, Inc., New York, pp.606-611,1989.
3. M. L. Appel et. al., "Beat to Beat Variability in Cardiovascular Variables: Noise or Music?" *Journal of American Coll. Physiology*, vol.14, pp.1139-1148, Nov.,1989.
4. I. I. Dardik, "The Origin of Disease and Health Heart Waves: The Single Solution to Heart Rate Variability and Ischemic Preconditioning," *CYCLES*, vol. 46, No.3, 1996.
5. T. Hisako, M. Larson, F. Venditti, E. Manders, C. Feldman, D. Levy, "Impact of Reduced Heart Rate Variability on Risk for Cardiac Events: The Framingham Heart Study," *Circulation*, vol.94 no.11, pp. 2850-2855, December 1, 1996.
6. Polar Electro Oy, "Polar HR Analysis Software: Section 1.1 to Section 2.9," *Polar Precision Performance Software: User's Manual 2nd Edition*, Polar Electro Inc., Kempele, pp. 3-61, 1995.
7. R. P. Sloan, P. A. Shapiro et. al., "Effect of mental stress throughout the day on cardiac autonomic control." *Biological Psychology*, vol. 37 no. 2, pp. 89-99, March 1994.
8. L. Bernardi, L. Ricordi et. al., "Impaired circadian modulation of sympathovagal activity in diabetes. A possible explanation for altered temporal onset of cardiovascular disease." *Circulation*, vol. 86 no. 5, pp. 1443-1452, November 1992.
9. H. V. Huikuri, J. O. Valkama et. al., "Frequency domain measures of heart rate variability before the onset of nonsustained and sustained ventricular tachycardia in patients with coronary artery disease." *Circulation*, vol. 87 no. 4, pp. 1220-1228, April 1993.
10. G. E. Billman, R. S. Hoskins, "Time-series analysis of heart rate variability during submaximal exercise. Evidence for reduced cardiac vagal tone in animals susceptible to ventricular fibrillation." *Circulation*, vol. 80 no. 1, pp. 146-157, July 1989.
11. H. V. Huikuri, M. J. Niemela et. al., "Circadian rhythms of frequency domain measures of heart rate variability in healthy subjects and patients with coronary artery disease. Effects of arousal and upright posture." *Circulation*, vol. 90 no. 1, pp.121-126, July 1994.

12. S. S. Hull Jr., A. R. Evans et. al., "Heart rate variability before and after myocardial infarction in conscious dogs at high and low risk of sudden death." *Journal of American Coll. Cardiology*, vol. 16 no. 4, pp. 978-985, October 1990.
13. Y. Ichimaru, H Tanaka, K Hirata, S Katayama, "Central Regulation of 1/f Fluctuations of Heart Rate Variability in Patients with Coma," *Computers in Cardiology*, IEEE Computer Society Press, pp.381-384, 1994.
14. Y. Ichimaru, Y. Kodama, T. Yanaga, "Circadian changes of HRV." *Computers in Cardiology*, IEEE Computer Society Press, pp. 657-660, 1988.
15. J. P. Saul, P. Albrecht, R. D. Berger, R. J. Cohen, "Analysis of long term HRV: Methods, 1/f scaling and implications," *Computers in Cardiology*, IEEE Computer Society Press, pp. 419-422, 1987.
16. M. Kobayashi, T. Musha, "1/f fluctuation of heart beat period," *IEEE Transactions of Biomedical Engineering*, BME, vol. 29, pp.456-457, 1982.
17. Y. Yamamoto, Y. Nakamura, H. Sato, M. Yamamoto, K. Kato, R. L. Hughson, "On the fractal nature of heart rate variability in humans: effects of vagal blockade," *American Journal of Physiology*, vol. 269, pp.R830-R837, Oct. 1995.
18. Y. Yamamoto, R. L. Hughson, "On the fractal nature of heart rate variability in humans: effects of data length and B-adrenergic blockade," *American Journal of Physiology*, vol. 266, pp. R40-R49, Jan.1994.
19. M. Burguera, R. Gandia, et.al., "Continuous heart rate variability monitoring through complex demodulation implemented with the fast Fourier transform and its inverse," *Pacing Clinical Eelctrophysiology*, vol 18:7, pp.1401-1410, July 1995.
20. G. Venkatesh, E. L. Fallen et. al., "Double blind placebo controlled trial of short term transdermal scopolamine on heart rate variability in patients with chronic heart failure," *Heart*, vol. 76:2, pp.137-143, Aug. 1996.
21. S. Chakko, R. F. Mulingtapang et. al., "Alterations in the heart rate variability and its circadian rhythm in hypertensive patients with left ventricular hypertropy free of coronary artery disease," *American Heart Journal*, vol. 126:6, pp.1364-1372, December 1993.
22. G. Panina, U. N. Khot et. al., "Assessment of autonomic tone over 24-hour period in patients with congestive heart failure: relation between mean heart rate and measures of heart rate variability," *American Heart Journal*, vol. 129:4, pp. 748-753, April 1995.

23. J. K. Kanters, E. Agner et. al., "Short- and long-term variations in non-linear dynamics of heart rate variability." *Cardiovascular Research*, vol. 31 no. 3, pp. 400-409, March 1996.
24. S. Guzzetti, M. G. Signorini et. al., "Non-linear dynamics and chaotic indices in heart rate variability of normal subjects and heart-transplant patients." *Cardiovascular Research*, vol.31 no. 3, pp. 441-446, March 1996.
25. A. Voss, J. Kurths et. al., "The application of methods of non-linear dynamics for the improved and predictive recognition of patients threatened by sudden cardiac death." *Cardiovascular Research*, vol. 31 no. 3, pp. 419-433, March 1996.
26. T. H. Makikallio, T. Seppanen et. al., "Abnormalities in beat to beat complexity of heart rate dynamics in patients with a previous myocardial infarction." *Journal of American Coll. Cardiology*, vol. 28 no. 4, pp. 1005-1011, October 1996.
27. Polar Electro Oy, *Polar Vantage NV: User's Manual*, Polar Electro Inc., Port Washington, pp. 6-25, 1995.
28. L. K. Wells, *The LabVIEW Student Edition User's Guide*, Prentice Hall, Englewood Cliffs, pp. 6-8, 1995.