

## **Copyright Warning & Restrictions**

The copyright law of the United States (Title 17, United States Code) governs the making of photocopies or other reproductions of copyrighted material.

Under certain conditions specified in the law, libraries and archives are authorized to furnish a photocopy or other reproduction. One of these specified conditions is that the photocopy or reproduction is not to be “used for any purpose other than private study, scholarship, or research.” If a user makes a request for, or later uses, a photocopy or reproduction for purposes in excess of “fair use” that user may be liable for copyright infringement,

This institution reserves the right to refuse to accept a copying order if, in its judgment, fulfillment of the order would involve violation of copyright law.

**Please Note: The author retains the copyright while the New Jersey Institute of Technology reserves the right to distribute this thesis or dissertation**

Printing note: If you do not wish to print this page, then select “Pages from: first page # to: last page #” on the print dialog screen

The Van Houten library has removed some of the personal information and all signatures from the approval page and biographical sketches of theses and dissertations in order to protect the identity of NJIT graduates and faculty.

## ABSTRACT

### A STUDY TO ANALYZE AND IMPROVE MECHANICAL AND ELECTRO - MECHANICAL DESIGNS USING DESIGN FOR QUALITY MANUFACTURABILITY (DFQM) TECHNIQUE.

by  
**Bhavani P Veerapaneni**

The competitive nature of modern manufacturing demands that an innovative approach be used to build advanced and robust designs. Shortening the product development time, which is the period from initial design to full production, is a priority to most manufacturers today. Design for Quality Manufacturability (DFQM) is a methodology to address manufacturing / assembly quality issues during product design. As a consequence DFQM helps shorten the product development time.

The DFQM methodology addresses the issue of quality manufacturability (QM) – the likely hood that defects will occur during the manufacture of a product in a standard plant. The DFQM architecture identifies a variety of design factors and variables that influence specific defects. The error catalysts are described in the form of catalysis graphs. Each catalysis graph leads to a value between “0” and “1”, based on the factor variables for the given design, implying the likelihood of occurrence of the specific defect. The overall QM index of design is derived from these values.

In this thesis we introduce new error catalysts for the DFQM method. Further, we conducted case studies of a variety of designs and we present a couple of them in this thesis.

**A STUDY TO ANALYZE AND IMPROVE MECHANICAL AND  
ELECTRO - MECHANICAL DESIGNS USING DESIGN FOR  
QUALITY MANUFACTURABILITY (DFQM) TECHNIQUE**

by  
**Bhavani P Veerapaneni**

**A Thesis  
Submitted to the Faculty of  
New Jersey Institute of Technology  
in Partial Fulfillment of the Requirements for the Degree of  
Master of Science in Industrial Engineering**

**Department of Industrial and Manufacturing Engineering**

**January 1998**

Blank Page

**APPROVAL PAGE**

**A Study to Analyze and Improve  
Mechanical and Electro - Mechanical Designs using  
Design for Quality Manufacturability (DFQM) Technique.**

Bhavani P Veerapaneni

---

Dr. Sanchoy K. Das, Thesis Advisor  
Associate Professor of Industrial Engineering, NJIT

Date

---

Dr. George Hanna Abdou, Committee Member  
Associate Professor of Industrial and Manufacturing Engineering, NJIT

Date

---

Dr. Rajpal S. Sodhi, Committee Member  
Associate Professor of Mechanical Engineering, NJIT

Date

## BIOGRAPHICAL SKETCH

**Author:** Bhavani P Veerapaneni  
**Degree:** Master of Science in Industrial Engineering  
**Date:** January 1998

### **Undergraduate and Graduate Education:**

- Master of Science in Industrial Engineering,  
New Jersey Institute of Technology, Newark, New Jersey, 1998
- Bachelor of Engineering in Mechanical Engineering,  
Bangalore University, Bangalore, India, 1995

**Major:** Industrial Engineering

**Dedicated to my Parents**



## ACKNOWLEDGMENT

The author wishes to express his profound gratitude to his advisor, Dr. Sanchoy K. Das, for his support demeanor, brilliant guidance and encouragement throughout this research.

Heartfelt gratitude to Dr. Rajpal Singh Sodi and Dr. George Hanna Abdou for serving as members of the committee.

The author is grateful for the constructive criticisms and help from Mr. Vikram V. Datla, Mr. Prashant Patel, and Mr. Narendra Raj. The author also wishes to acknowledge Ms. Alicia Suh for her assistance in documenting the research work and assisting in the lab.

The author would like to thank Dr. Ronald Kane and Ms. Annette Damiano for their time and the help they rendered in the documentation of this thesis

Finally the author would like to thank God, for putting him in the hands of such good and highly knowledgeable people.

## TABLE OF CONTENTS

Chapter	Page
1. INTRODUCTION .....	1
1.1 Product Development Cycle .....	1
1.2 Design for Manufacture .....	3
1.3 Design for Quality Manufacturability .....	4
1.4 Research Objective .....	5
1.5 Organization of the Thesis .....	5
2. LITERATURE SURVEY .....	6
2.1 Quality in Design .....	6
2.2 Concurrent Engineering .....	7
2.3 Design for Manufacture Techniques .....	8
2.4 Design for Quality Manufacturability (DFQM) .....	9
2.5 Summary .....	10
3. DFQM ANALYSIS OF DEFECT CLASSES .....	12
3.1 DFQM Methodology .....	12
3.2 Concept of Error Catalysts .....	12
3.3 Quality Manufacturability Analysis .....	14
3.4 Analysis of Missing / Misplaced Parts .....	16
3.5 Analysis of Misaligned Parts .....	19
3.6 Fastener Related Problems .....	24
3.7 Parts Damage .....	29

**TABLE OF CONTENTS**  
**(Continued)**

<b>Chapter</b>	<b>Page</b>
4. DFQM ANALYSIS OF MECHANICAL ASSEMBLIES .....	33
4.1 Door Handle Assembly Components and Procedure .....	33
4.2 The DFQM Analysis on the Design and the QM Matrix .....	35
4.2.1 Misplaced or Missing of Parts .....	35
4.2.2 Part Misalignment .....	37
4.2.3 Part Interference .....	38
4.2.4 Fastener Related Defect .....	39
4.2.5 Total Non Conformity .....	40
4.2.6 Damaged Parts .....	41
4.2.7 QM Index Matrix Report .....	42
4.3 Proposed Design Changes Based on the DFQM Scores .....	43
5. DFQM ANALYSIS OF AN ELECTRO MECHANICAL ASSEMBLY .....	44
5.1 Cellular Phone Assembly Procedure and Components .....	44
5.1.1 Cellular Phone Components .....	44
5.1.2 Cellular Phone Assembly Sequence .....	44
5.2 The DFQM Analysis and the QM Matrix for the Cellular Phone .....	46
5.2.1 Misplaced or Missing Parts .....	47
5.2.2 Part Misalignments .....	48
5.2.3 Part Interface .....	50
5.2.4 Fastener Related .....	51
5.2.5 Total Nonconformity .....	52

**TABLE of CONTENTS**  
**(Continued)**

<b>Chapter</b>	<b>Page</b>
5.2.6 Damaged Parts Defects Report .....	53
5.3 QM – Index Matrix Report .....	55
5.4 Design Changes Based on the DFQM Scores .....	56
6. CONCLUSION AND FUTURE WORK .....	58
6.1 Conclusions .....	58
6.2 Computerized DFQM Analysis .....	59
6.3 Future Work .....	59
APPENDIX A: DFQM Architecture .....	60
APPENDIX B: FASTENER CHART .....	61
APPENDIX C: POSITIONAL CHART .....	62
APPENDIX D: FUNCTIONAL CHART .....	63
REFERENCES .....	64

## LIST OF TABLES

<b>Table</b>	<b>Page</b>
Metrics involved in Qualification of Factor Variables .....	13

## LIST OF FIGURES

Figure	Page
3.1 QM Index Matrix Report .....	15
3.2 Catalysis sheet for direction of assembly of parts in automatic assembly .....	17
3.3 Catalysis sheet for the volume of the product creating difficulty in manual assembly .....	18
3.4 Catalysis sheet for Inability to maintain alignment with all mating surfaces .....	20
3.5 Catalysis sheet for an eccentric weighing part hinged (pivoted) at one end .....	21
3.6 Catalysis sheet for direction of assembly of parts in automatic assembly .....	22
3.7 Catalysis sheet for manual handling of heavy parts with out the use of additional equipment .....	23
3.8 Catalysis sheet for failure due to use of wrong kind of fastener .....	25
3.9 Catalysis sheet for the use of material other than plastic resulting in fastener failure .....	26
3.10 Catalysis sheet for, if only snap fits were used to fasten two rectangular sections .....	27
3.11 Catalysis sheet for direction of assembly and absence of positioning elements .....	28
3.12 Catalysis sheet for Part inserted into another component without guides .....	30
3.13 Catalysis sheet for insertion of a part into a blind hole .....	31
3.14 Catalysis sheet for rigid snap material causing aesthetic damage to the product .....	32
4.1 Door handle exploded assembly drawing .....	34

**LIST OF FIGURES**  
**(Continued)**

<b>Figure</b>	<b>Page</b>
4.2 QM matrix for missing and misaligned defects report for the door handle .....	35
4.3 QM matrix for misalignment defect report for the door handle .....	37
4.4 QM matrix for Interference defect report for the door handle .....	38
4.5 QM matrix for Fastener Related Defects Report for the door handle .....	39
4.6 QM matrix for Nonconforming Defects report for the door handle .....	40
4.7 QM matrix for damaged parts for the door handle .....	41
4.8 QM Index Matrix report for the Door handle for the door handle .....	42
5.1 Assembly drawing of a cellular phone .....	45
5.2 QM matrix for Missing and Misplaced Defects Report for the cellular phone	47
5.3 QM matrix for Misaligned defects report for the cellular phone .....	48
5.4 QM matrix for interference of parts for the cellular phone .....	50
5.5 QM matrix for Fastener related defects report for the cellular phone .....	51
5.6 QM Matrix for Total non-conformity of parts for the cellular phone .....	52
5.7 QM matrix for damaged parts for the cellular phone .....	53
5.8 QM matrix for damaged parts for the cellular phone .....	55

# CHAPTER 1

## INTRODUCTION

### 1.1 Product Development Cycle

Rigorous international competition, expansion of consumer markets and rapid technology changes have created a set of competitive imperatives (speed, efficiency, and quality) for the development of new products and processes. Firms that get to the market faster and efficiently with quality products that well match customer needs are the kind of firms that will not only stay in business but also create significant competitiveness in the market. DFQM helps in reducing the product development time. In a sense it helps to bring high quality products into the market place in a lesser amount of time.

New product or process development involves complex set of activities that cut across most business functions. Traditionally, in first two phases-concept development and product planning – information about market opportunities, competitive moves, technical possibilities, and production requirements are analyzed to develop the initial design. Once approved, the project moves into the detailed engineering phase, where design and construction of a working model is formed and then subjected to tests that simulate product use. The conclusion of the detailed engineering phase of product development is marked by an engineering “release”. At this time the firm typically moves development into pilot manufacturing phase, during which the individual components are build, assembled and tested on factory equipment. Typically, during this phase, a number design and manufacturing difficulties are resolved by iterative method. At the end of this phase, the



firm produces products for commercial sale i.e. it builds the product to meet the market requirement.

In order to minimize production turn around time manufacturers have started to address manufacturability quality issues or production quality issues before the actual production. This has led to the concept of building the product for ease of manufacture and assembly. It is estimated that approximately 75 % to 80 % of the product cost are determined at the design stage. It is therefore important that all down stream issues be analyzed during design. As a result of this, people from different areas, product design, engineering, process, production, quality, and marketing started getting involved at design stage and worked as a team to introduce right product at right cost and at right time. This gave rise to terms like, “Concurrent Engineering” or “Simultaneous Engineering”. Concurrent Engineering is a systematic approach to the integrated, concurrent design of products and their related processes, including manufacturing and support. This approach is intended to cause the developers, from the outset, to consider all elements of the product life cycle from concept through disposal, including quality, cost, schedule, and user requirements. There are many internal and external technical, human and legal factors that put increasing pressure on the concurrent engineering team when designing a new product. Design for manufacturing (DFM or DFA) is a tool, which systematically analyzes each part or sub-assembly from a manufacturing perspective.

## 1.2 Design for Manufacture

Design for Manufacture in the broadest sense, means designing quality and “manufacturability” into the product and the required processes simultaneously. Manufacturability is defined as ease to manufacture any product. Any considerations related to manufacturing made during product development stage results into higher manufacturability of the product. The goals of DFM are to (i). Minimize the product development cycle time, (ii) minimize the design to production transition time and (iii) minimize the number of design changes due to manufacturing difficulty.

During each phase of product development, several technical and economical decisions need to be made. The quality of the decisions often depends on the information available during design stage. Every design decision, if not considered carefully, can cost unnecessary manufacturing effort and loss. Normally, it has been found that design changes are made due to lack of information on path that products have to follow before reaching to the end user of the product, i.e. manufacturing, marketing, shipping, etc. The DFM approach tries to minimize design changes and thus help’s to get product to the market faster.

DFM represents a new awareness of the importance of design as the first manufacturing step. It recognizes that a company cannot meet quality and cost objectives with isolated design and manufacturing engineering operations. DFM approach integrates the product design and process planning into one common activity and embodies certain underlying imperatives that help to maintain communication between all components of manufacturing system and permit flexibility to adapt and to modify the design during each stage of the product development. Various different DFM tools are available to accomplish

the above mentioned objectives. However the only known technique that evaluates the manufactured quality of the product design is the Design for Quality Manufacturability (DFQM).

### 1.3 Design for Quality Manufacturability

The quality manufacturability of a design is defined as the likelihood that defects will occur during its manufacture in a standard product. Design for Quality Manufacturability (DFQM) is an approach involving the activities of product design, manufacturability analysis, process design and quality management for the efficient design of products, which have a very low, or almost no chance of producing defects. The main objective of DFQM is to enable user to improve the design so as to reduce the likelihood of defective product being manufactured.

The spectrum of quality defects by Das (1993), shown in fig 1.1

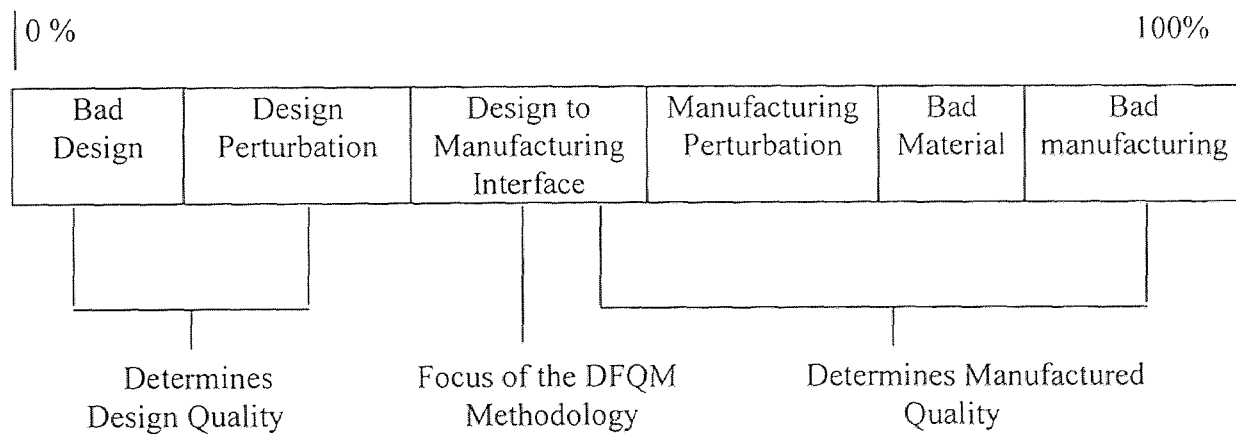

**Figure 1.1** Spectrum of Quality Defects

Illustrates the source of quality problems while several techniques and tools are available to analyze quality defects. The design to manufacturing interface is not formally addressed. (The Appendix B gives a macroscopic view of the DFQM schema) The focus of DFQM is therefore to the design to manufacturing interface, and how it effects.

#### **1.4 Research Objective**

This thesis forms a part of a seven-year research, which is currently underway. The research is partially funded by a grant from the National Science Foundation (NSF). Using the DFQM architecture this thesis proceeds to add further error catalysts to the existing set of error catalysts. DFQM analysis is done on a series of Electro-mechanical components to illustrate the practical feasibility of the methodology.

#### **1.5 Organization of the Thesis**

The thesis consists of five chapters. The first chapter introduces the concept of DFQM and its importance in manufacturing. The second chapter gives a survey of relevant literature on Design for Assembly (DFA), Design for manufacturability (DFM) and current research in Design for Quality Manufacturability (DFQM). In the third chapter error catalysts are added to the present error catalysts for the following specific defects: Misplaced and Missing parts, Part Misalignment, Fastener related problems and Parts Damage specific defects. In the fourth chapter mechanical and Electro mechanical designs are analyzed to show the feasibility and the actual practical application of the DFQM technique. Chapter five contains the conclusion and scope for further research in the area of DFQM.

## CHAPTER 2

### LITERATURE SURVEY

#### 2.1 Quality in Design

In today's highly competitive market environment, designers are forced to come up with new designs in a very short time, leading to a wide variety of products and shorter product life cycles. This means that the manufacturing floor has to deal with more and more designs in a very short time and still produce very high quality goods. Eventually the manufacturing floor cannot keep up with this variability and the quality of the goods fall. Variability reduction and robustness against variation of hard-to-control factors are therefore recognized as being of utmost importance in the quest for high quality products. Quality of any product can be broadly defined into two categories, namely: design quality and manufactured quality. Design quality is defined as the quality of a product as perceived by the customer. On the other hand, manufactured quality is defined as the extent to which a product deviates from its design specifications.

Traditional approaches to improving the quality of the product have been focused on either monitoring the process itself or inspecting the output of the process. Deming (1988) complains that manufacturers are too dependent on inspection as the means to high quality, rather than problem solving methods which prevent low quality from occurring in the first place. In response to a call for quality prevention approaches several new methods have been reported in this literature.

The concept of “Quality by Design” (Deming 1988, Clausing and Simpson 1990) emphasizes on prevention rather than problem solving. Statistical process control techniques, cause-Effect analysis (Ishikawa 1943) are used to identify potential source of quality problems. Huthwaite (1989), Yost (1987) evaluated the advantages of building quality in the design rather than developing in after the product has been produced. Taguchi (1979), design for quality involves a three-step optimization of product and process: system design, parameter design and tolerance design. This approach suggests that key to minimizing variability in a product’s functional characteristics is to systematically select values for controlling factors such as sensitivity to uncontrollable factors in minimized.

## **2.2 Concurrent Engineering**

Concurrent engineering (CE) is a multi disciplinary or a multifunctional team and a set of associated tools. A model to improve the design by synthesizing and evaluating the design prior to production was proposed by Shingley (1963). The concurrent engineering approach is an extension of Shingley's model to enhance design techniques. An Axiomatic Approach proposed by Suh, Bell, and Gussard (1978) is based upon hypothesis that there exists a small set of global principles, or axioms which can be applied to decisions made throughout the synthesis of manufacturing system including evaluation of a design decision leading to a good design. The product realization process that combines the activities of design, concurrent engineering, and customer needs interpretation. This called a systems approach towards product design integration with all the facets of the manufacturing process. This is capitalized as the Concurrent Engineering approach to product design (Das 1993).

The multi disciplinary task force approach is fundamental to the CE, a task force approach to project management with a number of specialized techniques that ensure a design is optimized - from all aspects, not just function. These include manufacture, assembly, maintenance / servicing, spares, and lifetime performance, including recycling. If a change in legislation or in the market adds new factors - a specialist can be added to the team.

To exploit the concept of concurrent engineering, information technology is extensively used to bring together these multidisciplinary teams. The associated tools with CE are Design for Manufacture (DFM), Design for X's (DFX), Quality Function Deployment (QFD) and Total Quality Management (TQM).

### **2.3 Design for Manufacture Techniques**

There are a few techniques that are widely used in industry and one such popular method is the Design for Manufacture and Assembly (DFMA) developed by Boothroyd and Dewhurst (1983). This technique involves analytical tools that allow designers and manufactures to calculate the design efficiency by evaluating the orienting, handling and assembly difficulty. Stoll (1988) proposed a similar DFM method that optimizes both process and product.

Many industrial houses developed similar methodologies, which were tailor made to their individual product line and business. One such methodology is the Hitachi Assembly Evaluation method. This method focuses on the cost involved in handling and assembly of the parts and identifies areas of focus for efficient product assembly. Westinghouse Corporation developed the DFM calculator, it uses simulation technique to analyze complex assemblies prior to their prototype production and enable designers to make changes in the

design, and study the assembly process variables. The U.S. department of Navy releases a document describing two manufacturability evaluation tools, first computes Producability Assessment work sheet Index (PAW-I) and second one evaluates the impact of product and process variation on product quality.

Priest and Sanchez have developed an empirical methodology that evaluates manufacturability by computing the productivity index (PI) of design by considering material selection, availability, commonality, standardization, process selection, tolerancing, quality, inspection and assembly system considerations.

#### **2.4 Design for Quality Manufacturability (DFQM)**

All the above mentioned techniques do focus on methods to improve the manufacturability of a design but the emphasis on quality of the design is clearly lacking. Most of the methodologies assume that since the manufacturability of the product improves, the quality of the product improves also.

Das (1993) and Prasad (1992) address the direct relationship between the design of the product and its manufactured quality. They initiated a methodology that focuses exclusively on evaluating a design from the manufactured quality of the product. This can help a designer in not only optimizing the manufacturability of the product but also allows him to address multiple quality issue that could affect the product at a downstream stage. It gives designers an estimate of the quality of design from the manufactured quality perspective by giving quantitative score of his design and directing his focus on improving certain features of design in order to improve overall quality manufacturability of the product.



The general structure (Prasad 1992) of this methodology is depicted in the DFQM architecture. This enables to accomplish a reverse cause- effect analysis by predicting the effect after identifying the causes. This methodology identifies a set of defects that occur at the assembly stage of the manufactured product. Sets of factors responsible for the occurrence of these defects are also investigated. The relationships to bring about an effective link between the defects and influencing factors is proposed in form of an error catalysts. This work forms the basis for the present work.

Suriyanarayanan (1994) studied the widely used assembly processes like insertion, riveting, welding, fastening, press-fit and snap-fit to analyze the techniques, capabilities, and limitations. Tamboo (1994) has studied the defect classes missing/misplaced parts and part interference's and identified factor variables using catalysis graphs. Dhar (1995) specifically studied and addressed the fastener-related problems and part misalignment during the assembly of the product. This also identified the error catalysts that promote the occurrence of these defects and related them to affecting factor variables using catalysis graphs. Datla (1997) addressed the issue of improving the design using reverse analysis.

## 2.5 Summary

Concurrent Engineering has opened a new approach to product design. The importance of design time decisions and their far reaching implications has created a lot of methodologies and software's which can be utilized to enhance the predictive capability of the designer in terms of testing, schedulability, manufacturability etc. Utilizing these established methodologies designers can reduce the number of iterations traditionally involved in the

design thus greatly reducing the development time. This power to effectively predict and control downstream issues has been developed into application software which help designers to objectively analyze their designs and address areas which need addressing.

The quality of the product has been by large reduced to a post design function. Present thought assumes that the quality of the product is independent from the design in the sense that improved manufacturability guarantees improved quality so there is little emphasis on the design for manufacturability perspective. This area is recognized for it's importance and is addressed in this thesis.

## CHAPTER 3

### DFQM ANALYSIS OF DEFECT CLASSES

#### 3.1 DFQM Methodology

A Macro approach has been identified by Das S. K in improving the quality issues in the assembled parts. This methodology classifies the possible defects that occur in an assembly into 'Defect Classes' which are a group of 'Specific Defects', these specific errors are in turn caused due to the presence of one or more 'Factor Variables'. The specific conditions that catalyze the presence of factor variables into specific defects are known as 'Error Catalysts'. The factor variables have been classified into groups or classes known as 'Influencing Factors'. This scheme has been illustrated in a schematic diagram in the appendix.

The error catalysts cause the specific defects to occur but it entirely depends on the factor variables, these factor variables are variable to each design. We are concerned with the design parameters that cause the specific defect to arise in a design. A systematic methodology was followed in this work based on decision trees. Error catalysts were identified and then the analysis was performed using decision trees by using what is called as the 'Catalysts Graphs'.

#### 3.2 Concept of Error Catalysts

Factor variables as it indicates are the variable quantities, different permutations cause different specific defects to occur. Also, different error catalysts may cause the same specific defect. In order to analyze this complex situation an analysis was done for each specific defect for its various error catalysts. As mentioned earlier decision trees were

used to drive the analysis. As a part of this thesis error catalyst graph sheets were prepared for each error catalyst under specific defect. This thesis concentrates on error catalysts for four specific defects, the four specific defects are

1. Misplaced and Missing parts
2. Misalignment
3. Fastener related problems
4. and Parts Damage.

These error catalysts are an extension to earlier work done in this field by Dhar, Gami, and Thamboo. Since this thesis is a part of an ongoing research, the error catalyst sheets not only provide consistency but also help as an easy reference. The analysis is done by first identifying all the error catalysts that can cause a specific defect and consequently the error catalyst graphs were drawn. All factor variables were also identified or quantified using the metrics that shall be followed consistently for the entire DFQM analysis. Table 3.1 gives metrics that was used for other factor variables.

**Table 3.1** Metrics involved in Qualification of Factor variables

	<b>FACTOR VARIABLES</b>	<b>MEASUREMENT or IDENTIFICATION SCHEME</b>
1	Shape and Symmetry	DFQM Classification of parts by Symmetry and Geometry
2	Mating Features	Number of mating surfaces and number of mating parts
3	Coefficient of thermal expansion	Ratio of Coefficient of two mating parts

**Table 3.1 (Continued)**

	<b>FACTOR VARIABLES</b>	<b>MEASUREMENT or IDENTIFICATION SCHEME</b>
4	Hardness	Hardness number ranges
5	Stress Properties	Ranges of Traditional Strength measuring units
6	Assembly Fixturing method	Automatic, Manual, or Robotic Assembly
7	Assembly sequence	Chronological
8	Functional and Motion relationship	DFQM Classification of Functional Relationship (Appendix D)
9	Fitting Relationship	Press Fit, Loose fit, and Running Fit
10	Positional Relationship	Positional Relationship chart (Appendix C)
11	Fastening Sequence	Sequence
12	Fastening Type, Strength	Fastening Classification and Identification Chart (Appendix B)

### 3.3 Quality Manufacturability Analysis

Tamboo (1994) and Dhar (1995) have explained the Quality Manufacturability (QM) analysis in detail but a brief review is provided.

The analysis results in a matrix of values called the Quality Manufacturability matrix (QMM). This matrix is indicative of the relative likelihood of the various defect classes.

Figure 3.1 shows the format for the QMM.

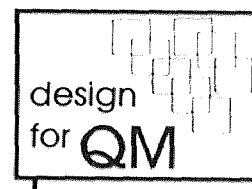

## QM-Index Matrix Report

Design Name: X

Design Number: 001

Date: 11/11/97

<i>Part Name</i>	<i>Defect Classes</i>					
	<i>A</i> <i>Missing &amp; Misplaced</i>	<i>B</i> <i>Misaligned</i>	<i>C</i> <i>Part Interference's</i>	<i>D</i> <i>Fastener Problems</i>	<i>E</i> <i>Parts Nonconforming</i>	<i>F</i> <i>Physical Damage</i>
1	0.0	0.02	0.03	0.06	0.07	0.0
2	0.07	0.00	0.011	0.016	0.0	0.0
3	0.01	0.02	0.03	0.00	0.00	0.00
4	0.00	0.00	0.00	0.00	0.00	0.00

**Figure 3.1** Sample QM Index Matrix Report

A composite score is also obtained from this matrix which is the designated 'Design for Quality Manufacturability Index' (DFQM Index). For comparison of alternatives and changes designs this index can be effectively utilized. However, in conditions where when a design is under improvement a designer needs to identify areas which require the most detailed analysis. These are identified from the matrix, where the defect with the most relative occurrence can be tackled first for purposes of improvement efforts. The nomenclature for calculations has been established as:

CD - Class of Defects

SD - Specific Defects

EC - Error Catalyst

k - Defect Classes

Missing Page

- $S_{d_{jk}}$  - Specific Defect 'j' belonging to Defect Class 'k'.
- $EC_{ijk}$  - Error Catalyst 'i' affecting Specific Defect 'j' which belongs to defect Class 'k'.
- $M_k$  - Number of SD belonging to  $DC_k$
- $N_{jk}$  - Number of EC affecting  $SD_{jk}$
- $p$  - 1...p
- $S_{ijk}$  - Score for  $EC_i$  influencing  $SD_{jk}$
- $W_{ijk}$  - Weightage on  $S_{ij}$  based on importance of  $EC_{ijk}$  for  $SD_{jk}$
- $Q_{jk}$  - QM score for each  $SD_j$  under  $CD_k$
- $F_{jk}$  - Multiplication factor for  $Q_{jk}$  based on relative importance of  $SD_j$  belonging to  $CD_k$
- $C_k$  - QM Score for each  $C_{dk}$

The equations used in the analysis are

$$Q_{jk} = \frac{\sum S_{ijk} * W_{ijk}}{N_{jk}} \quad (3.1)$$

$$C_k = \frac{\sum Q_{jk} * F_{jk}}{M_k} \quad (3.2)$$

The equation 3.1 is used to determine the QM score for each specific defect and equation 3.2 provides the QM score for the defect class.

### 3.4 Analysis of Missing / Misplaced Parts

Thamboo did extensive work in this area of misplacement and misalignment of parts, this portion of the thesis is a continuation to his work. This defect is most common in manual



assembly than in automatic assembly. Primary influencing factors for this defect are the geometrical features and assembly procedure. The error catalysts shown in the following pages are based on this assembly procedure and volume of the product. The specific defect which these error catalyst cause is the Misposition of the parts. The error catalysts graphs are in a particular format to match up with the format used in earlier work so it would help in easy reference.

### ERROR CATALYSIS SHEET

<i>DEFECT CLASS</i>	<i>SPECIFIC DEFECT</i>	<i>SHEET NO:</i>
Missing/ Misplaced Parts	Mispositioning	A-3-5
<i>ERROR CATALYST</i>		
Direction of assembly of parts in automatic assembly		
<i>DESCRIPTION</i>		
In automatic assembly when the parts have to follow multiple axis co ordinates then the chance of mispositioning of the part is very high. It is always advisable to design parts to facilitate negative Z-axis assembly or gravity axis assembly.		
<i>CATALYSIS GRAPH</i>		
<pre> graph TD     Start[Start analysis] --&gt; Type[Type of assembly]     Type -- Manual --&gt; C0((0))     Type -- Automatic --&gt; Equip[Presence of additional positioning equipment e.g., Vision system.]     Equip -- Yes --&gt; C1((0))     Equip -- No --&gt; Dir[Direction of Assembly]     Dir -- "X or Y axis" --&gt; C2((0.3))     Dir -- Multiple Axis --&gt; C3((0.7))     Dir -- "- ve Z axis" --&gt; C4((0))   </pre>		

Figure 3.2 Catalysis sheet for direction of assembly of parts in automatic assembly

## ERROR CATALYSIS SHEET

<i>DEFECT CLASS</i>	<i>SPECIFIC DEFECT</i>	<i>SHEET NO:</i>
Missing/Misplaced Parts	Misposition	A-3-6
<i>ERROR CATALYST</i>		
The volume of the product creates difficulty in manual assembly.		
<i>DESCRIPTION</i>		
<p>If the assembly is a manual assembly then the size of the parts play a big issue. In Manual assembly if the size of the component is small i.e. say less than <math>5 \text{ mm}^3</math> then the handling and orienting difficulty of the component increases this eventually leads to a high occurrence of mispositioning of the part.</p>		
<i>CATALYSIS GRAPH</i>		
<pre> graph TD     Start[Start analysis] --- Type[Type of Assembly]     Type --- Auto[Automatic / Semi Automatic]     Auto --- C0((0))     Type --- Manual[Manual]     Manual --- Volume[Volume of the component]     Volume --- V5["&lt; 5 mm³"]     V5 --- C04((0.4))     Volume --- V10["&gt; 5 mm³"]     V10 --- C0((0))           </pre>		

**Figure 3.3** Catalysis sheet for the volume of the product creating difficulty in manual assembly

### 3.5 Analysis of Misaligned Parts

Dhar (1995) did the analysis on quality defects arising from misalignment of parts. He in his thesis gives a description of different types of misalignments and how to analyze the misalignments. In this thesis I'll be presenting only the additional error catalysts and not a detail explanation of the misalignments. The following error catalysts cause all four types of specific defects. The catalyst graphs are self-explanatory.

## ERROR CATALYSIS SHEET

<i>DEFECT CLASS</i> Misalignments	<i>SPECIFIC DEFECT</i> Axial Misalignment	<i>SHEET NO:</i> <b>B-1-4</b>
<i>ERROR CATALYST</i> Inability to maintain alignment with all mating surfaces.		
<i>DESCRIPTION</i> In this error catalyst the decisive factor is the motion of the part. If a part has a pivotal motion like that of a car door and has multiple surfaces or components to align to, then the chances of axial misalignment are large. This could be avoided by providing positioning elements on the mating surfaces. These positioning elements not only provide support but also maintain axial alignment.		
<i>CATALYSIS GRAPH</i>		
<pre> graph TD     Start[Start Analysis] --&gt; Q1{Is the Part being fastened?}     Q1 -- No --&gt; R1((0))     Q1 -- Yes --&gt; Q2{Does the Part has Motion?}     Q2 -- No --&gt; R2((0))     Q2 -- Yes --&gt; Q3{What is the type of motion?}     Q3 -- Others --&gt; R3((0))     Q3 -- Pivotal --&gt; Q4{Number of Mating Surfaces.}     Q4 -- "&lt;= 2" --&gt; R4((0))     Q4 -- "&gt; 2" --&gt; Q5{Presence of Positioning elements to maintain Position.}     Q5 -- Yes --&gt; R5((0))     Q5 -- No --&gt; R6((0.6))     </pre>		

**Figure 3.4** Catalysis sheet for Inability to maintain alignment with all mating surfaces

## ERROR CATALYSIS SHEET

<i>DEFECT CLASS</i> Misalignments	<i>SPECIFIC DEFECT</i> Axial Misalignment	<i>SHEET NO:</i> <b>B-1-5</b>
<i>ERROR CATALYST</i> An eccentric weighing part hinged (pivoted) at one end.		
<i>DESCRIPTION</i> If a part is designed to be hinged at one end and the center of gravity of the part is at the other end then the part is bound to have a quality problem of axial misalignment. The part's natural resting position would be at the opposite end from the hinge.		
<i>CATALYSIS GRAPH</i> <pre> graph TD     Start[Start Analysis] --&gt; Q1{Is the Part being fastened?}     Q1 -- No --&gt; T1((0))     Q1 -- Yes --&gt; Q2{Does the Part has Motion}     Q2 -- No --&gt; T2((0))     Q2 -- Yes --&gt; Q3{What is the type of motion?}     Q3 -- Others --&gt; T3((0))     Q3 -- Pivotal --&gt; Q4{Is the center of gravity of the part, at the extreme end?}     Q4 -- No --&gt; T4((0))     Q4 -- Yes --&gt; T5((0.4))           </pre>		

**Figure 3.5** Catalysis sheet for an eccentric weighing part hinged (pivoted) at one end

### ERROR CATALYSIS SHEET

<i>DEFECT CLASS</i>  Misalignment	<i>SPECIFIC DEFECT</i> Axial, Radial, Linear and Angular Misalignment	<i>SHEET NO:</i>  B-1-6, B-2-4, B-3-4, B-4-3
<i>ERROR CATALYST</i> Direction of assembly of parts in automatic assembly		
<p><i>DESCRIPTION</i></p> <p>In an automatic assembly when the direction of assembly of a component is complex, i.e., the part has to come down on to the assembly following a complex contour the chances of this part to have a proper alignment is low with out the use of additional vision systems. This error catalyst produces all four types of specific defects.</p>		
<p><i>CATALYSIS GRAPH</i></p> <pre> graph TD     Start([Start analysis]) --- Type[Type of assembly]     Type -- Manual --&gt; C0((0))     Type -- Automatic --&gt; Equip[Presence of additional positioning equipment e.g., Vision system.]     Equip -- Yes --&gt; C1((0))     Equip -- No --&gt; Dir[Direction of Assembly]     Dir -- "X, Y or Z axis" --&gt; C2((0.3))     Dir -- Multiple Axis --&gt; C3((0.7))     Dir -- "- Ve Z axis" --&gt; C4((0))   </pre>		

**Figure 3.6** Catalysis sheet for direction of assembly of parts in automatic assembly

## ERROR CATALYSIS SHEET

<i>DEFECT CLASS</i>	<i>SPECIFIC DEFECT</i>	<i>SHEET NO:</i>
Part Misalignment	Axial/ Radial/ Linear/ Angular Misalignment	B-1-7, B-2-5, B-3-5, B-4-4
<i>ERROR CATALYST</i>		
Manual handling of Heavy parts with out additional equipment.		
<i>DESCRIPTION</i>		
This error catalyst considers a number of factors that could lead to the misalignment of the part. A combination of manual assembly, weight of the part, use of additional equipment and presence of supporting elements decide on the score for this defect class.		
<i>CATALYSIS GRAPH</i>		
<pre> graph TD     Start([Start analysis]) --&gt; Type[Type of assembly]     Type -- Automatic --&gt; S0((0))     Type -- Manual --&gt; Weight[Weight of the part]     Weight -- "&lt; 5 kg's" --&gt; S0     Weight -- "&gt; 5 kg's" --&gt; Equip[Use of additional equipment to align parts]     Equip -- Yes --&gt; S0     Equip -- No --&gt; Pos[Presence of positioning or supporting elements before fastening]     Pos -- Yes --&gt; S02((0.2))     Pos -- No --&gt; Dir[Direction of assembly]     Dir -- "+ Ve Z axis" --&gt; S05((0.5))     Dir -- "- Ve Z Axis" --&gt; S03((0.3))     Dir -- "x, y Axis" --&gt; S04((0.4)) </pre>		

**Figure 3.7** Catalysis sheet for manual handling of heavy parts with out the use of additional equipment

### **3.6 Fastener Related Problems**

Dhar (1995) conducted the previous analysis on fastener related problems, the specific defects that could possibly occur are Loose or Ill fitting of fasteners, Over tightening of fasteners, and fracture or failure of fasteners. Dhar (1995) in his thesis explains the occurrence of each specific defect with a set of error catalysts. In this thesis I have added to these specific defects a new set of error catalysts, these error catalysts are self explanatory as shown in the following pages.



### ERROR CATALYSIS SHEET

<i>DEFECT CLASS</i> Fastener Related Problems.	<i>SPECIFIC DEFECT</i> Fracture or Failure	<i>SHEET NO:</i>  <b>D-3-3</b>
<i>ERROR CATALYST</i> Failure due to use of wrong kind of fastener.		
<i>DESCRIPTION</i>  If the direction of separation force between two parts is different from the holding force of the fastener then the fastener failure is inevitable.		
<i>CATALYSIS GRAPH</i>  <div style="text-align: center;"> <pre> graph TD     Start[Start Analysis] --&gt; Q{Is the Part Being Fastened?}     Q -- No --&gt; C0((0))     Q -- Yes --&gt; D[Direction of Separation Force]     D -- A2 --&gt; T1[Type of Fastener]     D -- A3 --&gt; T2[Type of Fastener]     T1 -- Others --&gt; C1((0))     T1 -- "Nails, esp. single element fasteners" --&gt; C2((1.0))     T2 -- Snap fit --&gt; C3((0.7))     T2 -- Others --&gt; C4((0))     </pre> </div>		

**Figure 3.8** Catalysis sheet for failure due to use of wrong kind of fastener

### ERROR CATALYSIS SHEET

<i>DEFECT CLASS</i> Fastener Related Problems.	<i>SPECIFIC DEFECT</i> Fastener Fracture or Failure	<i>SHEET NO.:</i> <b>D -3-4</b>
<i>ERROR CATALYST</i> The use of material other than plastic resulting in fastener failure		
<i>DESCRIPTION</i> In fasteners such as snap fits where the flexibility of the fastener and the Co-efficient of friction between the fastener and part are the important factors, if the material used is rigid and coupled with a high Co-efficient of friction will result in a failure of the fastener.		
<i>CATALYSIS GRAPH</i>		
<pre> graph TD     A[Is the part being fastened?] -- No --&gt; B((0))     A -- Yes --&gt; C[Type of fastener]     C -- Others --&gt; D((0))     C -- Snap fit --&gt; E[Material Used]     E -- Plastic --&gt; F((0))     E -- Others --&gt; G[Coefficient of friction between the fastener surface &amp; the fastened material.]     G -- &lt;1.4 --&gt; H((0))     G -- &gt;1.4 --&gt; I((0.6))   </pre>		

**Figure 3.9** Catalysis sheet for the use of material other than plastic resulting in fastener failure

## ERROR CATALYSIS SHEET

<i>DEFECT CLASS</i>	<i>SPECIFIC DEFECT</i>	<i>SHEET NO:</i>
Fastener-related Problems	Fasteners failure or fracture	<b>D-3-5</b>
<i>ERROR CATALYST</i> If only snap fits are used to fasten two rectangular sections.		
<i>DESCRIPTION</i>  If only snap fits are used to fasten two rectangular sections and also the snaps are present on all the four sides of the rectangular section. It is required that positional elements are present for each and every snap or otherwise some snaps will snap leaving the other snaps open resulting in a fastener failure.		
<i>CATALYSIS GRAPH</i>		
<pre> graph TD     Start[Start analysis] --&gt; Fastener[Type of fastener used]     Fastener -- Other --&gt; C0_1((0))     Fastener -- Snap Fit --&gt; Geometry[Geometry of the mating parts]     Geometry -- Others --&gt; C0_2((0))     Geometry -- S1 to S23 --&gt; Positioning[Presence of positioning elements on the parts]     Positioning -- Yes --&gt; C0_3((0))     Positioning -- No --&gt; C0_5((0.5))           </pre>		

**Figure 3.10** Catalysis sheet for if only snap fits were used to fasten two rectangular sections

## ERROR CATALYSIS SHEET

<i>DEFECT CLASS</i> Fastener Related Problems	<i>SPECIFIC DEFECT</i> Ill Fitted Defect	<i>SHEET NO:</i>  <b>D-1-4</b>
<i>ERROR CATALYST</i> Direction of fastening and absence of positioning elements.		
<i>DESCRIPTION</i> When the direction of fastening is in a + ve Z-axis, where the applied force is against gravity and the part is not fixtured or supported sufficiently esp. in manual assembly where the weight of the part is supported by hand. This type of fastening would lead to a fastening failure due to the complexity in the fastening process.		
<i>CATALYSIS GRAPH</i>		
<pre> graph TD     Start[Start analysis] --&gt; Type[Type of assembly]     Type -- Automatic --&gt; C0((0))     Type -- Manual --&gt; Fastened{Is the part fastened?}     Fastened -- No --&gt; C1((0))     Fastened -- Yes --&gt; Direction[Direction of fastening]     Direction -- "X, Y, -Ve Z Axis" --&gt; C2((0))     Direction -- "+ Ve Z Axis (against gravity)" --&gt; Supported{Is the part sufficiently supported and positioned before fastening}     Supported -- No --&gt; C3((0.4))     Supported -- Yes --&gt; C4((0)) </pre>		

**Figure 3.11** Catalysis sheet for direction of assembly and absence of positioning elements

### 3.7 Parts Damage

Gami (1995) analyzed the occurrence of this defect class and created a set of error catalysts. This defect class comprises of two specific defects the aesthetic damage and physical damage of parts. Physical damage is one, which affects the functionality of the individual part or assembly as a whole and does not confirm with the design. This type of defect arises due to a combination of design features and poor material handling during manufacturing. Aesthetic damage to the part is damage that affects the appearance of the part without affecting the functionality of the part or assembly. I covered both these specific defects by creating new set of error catalysts in addition to Gami's work.

The analysis gives a score ranging from "0" to "1" depending on the type of error catalyst. The error catalysts that follow in the following pages are self-explanatory.

### ERROR CATALYSIS SHEET

<i>DEFECT CLASS</i> Damaged Parts	<i>SPECIFIC DEFECT</i> Physical Damage	<i>SHEET NO:</i> <b>F-1-5</b>
<i>ERROR CATALYST</i> Part inserted into another component without guides.		
<i>DESCRIPTION</i> The presence of chamfer or guide prevents physical damage to parts when two parts are inserted into each other. Damage could be caused to the parts when the tolerance is too tight or when the tolerance is too low. The tolerance value is not really the factor when it comes to insertion of parts into each other. If the material used is plastic then the chances for the parts damage is almost negligible.		
<i>CATALYSIS GRAPH</i>		
<pre> graph TD     Start[Start Analysis] --&gt; Q1{Part inserted into any other part.}     Q1 -- No --&gt; C1((0))     Q1 -- Yes --&gt; Q2{Type of material of the part}     Q2 -- Plastic --&gt; C2((0))     Q2 -- Others --&gt; Q3{Presence of chamfers}     Q3 -- No --&gt; C3((0.6))     Q3 -- Yes --&gt; C4((0))     </pre>		

Figure 3.12 Catalysis sheet for Part inserted into another component without guides

## ERROR CATALYSIS SHEET

<i>DEFECT CLASS</i> Damaged Parts	<i>SPECIFIC DEFECT</i> Physical Damage	<i>SHEET NO:</i> <b>F-1-6</b>
<i>ERROR CATALYST</i> Insertion of a part into a blind hole.		
<i>DESCRIPTION</i> If a tight insertion mating relationship exists between parts and one of the mating pairs has a blind hole and no provision is provided for the air to escape then the insertion difficulty increases resulting in using more force and a possible physical damage to one of the parts.		
<i>CATALYSIS GRAPH</i>		
<pre> graph TD     Start[Start analysis] --&gt; Q1{Is the part inserted into another part?}     Q1 -- No --&gt; O1((0))     Q1 -- Yes --&gt; Q2{Does one of the mating pairs have a blind hole.}     Q2 -- No --&gt; O2((0))     Q2 -- Yes --&gt; Q3{Type of fit}     Q3 -- Loose --&gt; O3((0))     Q3 -- Tight --&gt; Q4{Presence of air hole}     Q4 -- Yes --&gt; O4((0))     Q4 -- No --&gt; O5((0.3))           </pre>		

**Figure 3.13** Catalysis sheet for insertion of a part into a blind hole

## CHAPTER 4

### THE DFQM ANALYSIS FOR A CAR DOOR HANDLE ASSEMBLY

#### 4.1 Assembly Components and Procedure

The design for the door handle assembly included these following parts

1. The handle
2. Frame
3. Handle lock
4. Connecting rod
5. Spring and
6. Rubber lining

The design of the Door handle is complicated when it comes to automatic assembly. One of the major restriction with the design is the assembly cannot be done on a simple -ve Z-axis. It necessitates the need for manual assembly & increases the effort on inspection.

One of the major restrictions in the design is positioning of the spring before the connecting rod is welded on to the frame and handle. There has to be an external element to hold position of the spring as the frame is contoured and it does not have any natural resting position.

The assembly of the door handle has the following assembly sequence. The first part to come on to the assembly is the handle, then comes the frame, the rubber lining, Spring, The Connecting Rod, then the welding operation & finally the Lock.



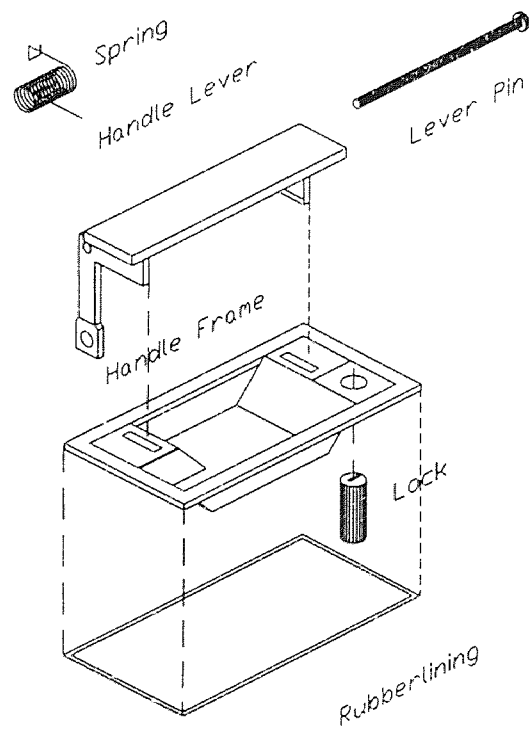
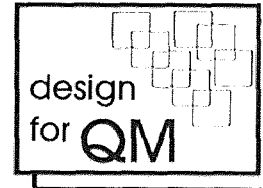

Figure 4.1 Door Handle Exploded Assembly Drawing

## 4.2 The DFQM Analysis on the Design and the QM Matrix

The DFQM analysis was conducted on the assembly and following results were arrived at.

### 4.2.1 Misplaced or Missing of Parts



## Missing & Misplaced Defects Report

---

Design Name: Door Handle

Design Number:

Date: 12/08/97

---

### *Maximum Error Catalyst Strength Matrix:*

<i>Part Name</i>	<i>Specific Defects</i>				<i>Average</i>
	<i>A1</i>	<i>A2</i>	<i>A3</i>	<i>A</i>	
	<i>Part Absent</i>	<i>Misplaced</i>	<i>Misposition</i>		
Frame	0.0	0.0	0.0		0.00
Handle	0.0	0.125	0.0		0.04
Lock	0.0	0.0	0.0		0.00
Rod	0.0	0.0	0.0		0.00
Rubber Lining	0.7	0.0	0.5		0.40
Spring	0.0	0.5	0.45		0.316

Figure 4.2 QM matrix for missing and misaligned defect report

The Results of DFQM Analysis indicates that the following two parts have adverse QM scores with reference to misalignment.

1. The Rubber Frame
2. The Spring

In addition the handle has score to a lesser degree.

The assembly of the rubberframe causes quality problems as this part is a flexible part and the part is not functionally critical to the assembly. The rubber frame is not attached to the frame but hangs on the handle, as it is not positioned at one particular position. The absence of this part is inevitable.

The spring does not have a positioning element on the frame nor can it be positioned at one particular position. The surface of the frame is curved thereby it does not allow the spring to have a natural resting position. The frame gets a score for misplacement because it has to follow a multiple axis path to complete the assembly.

## 4.2.2. Part Misalignment

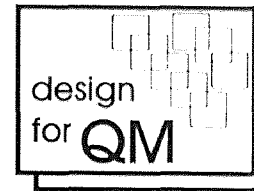

# Misalignments Defects Report

Design Name: Door Handle

Design Number:

Date: 12/08/97

### Maximum Error Catalyst Strength Matrix:

Part Name	Specific Defects				Average
	<i>B1</i>	<i>B2</i>	<i>B3</i>	<i>B4</i>	
	<i>Axial</i>	<i>Radial</i>	<i>Linear</i>	<i>Angular</i>	
Frame	0.0	0.0	0.0	0.00	0.00
Handle	<b>0.5</b>	0.0	0.0	<b>0.50</b>	<b>0.25</b>
Lock	0.0	0.0	0.0	0.00	0.00
Rod	<b>0.5</b>	0.0	0.0	<b>0.50</b>	<b>0.25</b>
Rubber Lining	0.0	0.0	0.0	0.00	0.00
Spring	0.0	0.0	0.0	0.00	0.00

**Figure 4.3** QM matrix for misalignment defect report

The results of DFQM Analysis indicates that the following parts have an adverse QM score with reference to missing and misplacement:

1. The Handle
2. The Rod

The handle is inserted into the frame and there are no positioning elements that position the handle other than the slots through which the frame passes through. As the handle

does not maintain exact position on the frame it draws a high score for misalignment with the frame.

The rod is inserted through the frame and the handle. If the handle does not maintain correct position with the frame then the rod would also get mispositioned. The rod once inserted on one side has to be inserted on the other side. The multiple mating relationship with no clear definition of position leads to the misalignment of the rod.

#### 4.2.3. Part Interference

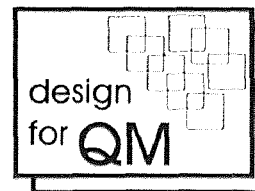

## Interference Defects Report

---

Design Name: Door Handle

Design Number:

Date: 12/08/97

---

*Maximum Error Catalyst Strength Matrix:*

*Specific Defects*

<i>Part Name</i>	<i>C1 Constant</i>	<i>C2 Occasional</i>	<i>C3 Intermittent</i>	<i>C Average</i>
Frame	0.0	0.0	0.0	0.00
Handle	0.0	<b>0.7</b>	0.0	<b>0.23</b>
Lock	0.0	0.0	0.0	0.00
Rod	<b>0.3</b>	0.0	0.0	<b>0.10</b>
Rubber Lining	0.0	0.0	0.0	0.00
Spring	0.0	0.0	0.0	0.00

**Figure 4.4** QM matrix for Interference defects report

The results of DFQM Analysis indicate that the following parts have a QM score with reference to Part Interference.

## 1. The Handle

## 2. The Rod

The Handle gets a score for Part interference as this part moves around in a pivotal motion and it is in constant interference with the frame. This interference removes the paint off the Frame & the handle. The only consolidation is that the area is not directly visible to the customer.

The rod has a QM score for interference with the spring but this is inevitable as the spring is designed to stay that way and it poses no major quality problem.

### 4.2.4. Fastener Related Defect

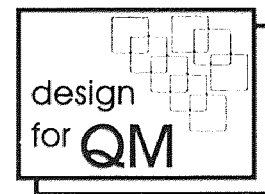

## Fastener Related Defects Report

Design Name: Door Handle

Design Number:

Date: 12/08/97

### *Maximum Error Catalyst Strength Matrix:*

<i>Part Name</i>	<i>Specific Defects</i>				<i>Average</i>
	<i>D1</i>	<i>D2</i>	<i>D3</i>	<i>D</i>	
	<i>Loose/Illfitted</i>	<i>Overtight</i>	<i>Fracture/Failure</i>		
Frame	0.0	0.0	0.0		0.00
Handle	0.0	0.0	0.0		0.00
Lock	0.0	0.0	0.0		0.00
Rod	0.0	0.0	0.0		0.00
Rubber Lining	0.0	0.0	0.0		0.00
Spring	0.0	0.0	0.0		0.00

**Figure 4.5** QM matrix for Fastener Related Defects Report

The whole assembly uses only one fastener, a weld. It is assumed in the analysis that the metals expand but stay within a certain range, due to heat applied during welding. The QM analysis does not see any Quality Problems due to welding.

#### 4.2.5. Total Nonconformity

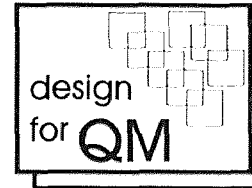

### Nonconforming Defects Report

Design Name: Door Handle

Design Number:

Date: 12/08/97

#### *Maximum Error Catalyst Strength Matrix:*

<i>Part Name</i>	<i>Specific Defects</i>				<i>Average</i>
	<i>E1</i>	<i>E2</i>	<i>E3</i>	<i>E</i>	
	<i>Dimensional</i>	<i>Design</i>	<i>Surface</i>		
Frame	0.0	0.0	0.0	0.00	
Handle	0.0	0.0	0.0	0.00	
Lock	0.0	0.0	0.0	0.00	
Rod	0.5	0.0	0.0	0.166	
Rubber Lining	0.0	0.0	0.0	0.00	
Spring	0.0	0.0	0.0	0.00	

**Figure 4.6** QM matrix for Nonconforming Defects report

The results of DFQM Analysis indicates that the following part has an adverse QM score with reference to Total Nonconformity:

1. The Rod

The rod has a high score because it being a slender long piece of aluminum the chances are that the part would get damaged and would lead to a total nonconformity, in other words it means that the part would not align itself to the frame and the handle.

#### 4.2.6. Damaged Parts

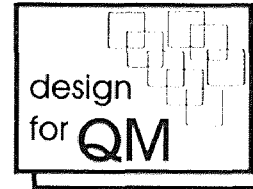

### Part Damage Defects Report

Design Name: Door Handle

Design Number:

Date: 12/08/97

#### *Maximum Error Catalyst Strength Matrix:*

<i>Part Name</i>	<i>Specific Defects</i>		
	<i>F1</i>	<i>F2</i>	<i>F</i>
	<i>Physical</i>	<i>Aesthetic</i>	<i>Average</i>
Frame	0.0	0.0	0.0
Handle	0.0	0.0	0.0
Lock	0.0	0.0	0.0
Rod	0.3	0.0	0.15
Rubber Lining	0.0	0.0	0.0
Spring	0.5	0.0	0.25

**Figure 4.7** QM matrix for damaged parts

The results of DFQM Analysis indicates that the following parts have an adverse QM score with reference to Damaged Parts:



1. Connecting Rod

2. Spring.

The score shows a value for the connecting rod and the spring, these parts will get damaged, as the assumption is that they will be handled in bulk and would lead to physical & aesthetically damage of the parts. The spring being an open edge helical spring leads to entanglement of parts. These entangled springs when separated have a high chance of causing damage to themselves.

#### 4.2.7 QM Index Matrix Report

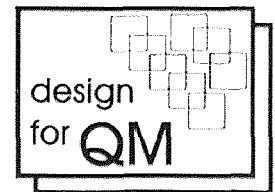

### QM-Index Matrix Report

---

Design Name: Door Handle                      Design Number:                      Date: 12/08/97

---

<i>Part Name</i>	<i>Defect Classes</i>					
	<i>A</i> <i>Missing &amp; Misplaced</i>	<i>B</i> <i>Misaligned</i>	<i>C</i> <i>Part Interference's</i>	<i>D</i> <i>Fastener Problems</i>	<i>E</i> <i>Parts Nonconforming</i>	<i>F</i> <i>Physical Damage</i>
Frame	0.00	0.00	0.0	0.00	0.00	0.00
Handle	<b>0.04</b>	<b>0.25</b>	<b>0.23</b>	0.00	0.00	0.00
Lock	0.00	0.0	0.0	0.00	0.00	0.00
Rod	0.00	<b>0.25</b>	<b>0.10</b>	0.00	<b>0.166</b>	<b>0.15</b>
Rubber Lining	<b>0.40</b>	0.0	0.0	0.00	0.00	0.00
Spring	<b>0.316</b>	0.0	0.0	0.00	0.00	<b>0.25</b>

---

**Figure 4.8** QM Index Matrix report for the Door handle

This figure shows the Executive report of the whole analysis. This report gives a designer a over all view of the design and then if the designer is interested in reducing a

particular score he can look at the detailed matrices and come to a conclusion on the design. Now lets look at the proposed design changes based on these scores.

### 4.3 Proposed Changes Based on the DFQM Scores

The **rubber frame** has the following design changes to reduce the scores.

1. The Rubber frame has provisions or holes in the corner and the frame has a corresponding protrusion. This allows the frame to stay in position once placed on the frame.

2. The rubber frame is glued on to the frame so that it maintains it position at all times.

The **Connecting Rod** has the following design changes to reduce the scores

1. The cross section of the connecting rod is increased so that the non-conformance defect is reduced.

2. To reduce the misalignment of the rod guides are provided so that when the rod is inserted minimum amount of effort is required to align the part with the frame and the handle.

The **Frame** has the following design changes to reduce the scores

1. The slots provided for inserting the handle are reduced and chamfers are provided on the frame to allow easy insertion. This also reduces the chance of misalignment of the handle as the handle has less room to move and maintains position.

2. The frame also has a slot to position the spring on its surface. The positioning elements are placed such that the spring rests in its natural position. This reduces the chance of misplacement of the spring.

## CHAPTER 5

### THE DFQM ANALYSIS FOR A CELLULAR PHONE ASSEMBLY

#### 5.1 Cellular Phone Assembly and Components

##### 5.1.1 Cellular Phone Components

The design for the cellular phone assembly includes the following parts.

1. The Lower Housing
2. Chassis
3. The Upper Housing
4. Small Circuit Board
5. Large Circuit Board
6. Antenna
7. Keypad
8. LCD
9. LCD lens
10. Plastic Outer Case
11. Microphone
12. Receiver

##### 5.1.2 Cellular Phone Assembly Sequence

The cellular phone is assembled in the following sequence.

The lower housing is the first to come on to the assembly. The small Circuit is placed on the lower housing, followed by the chassis. The plastic outer casing for the antenna comes in

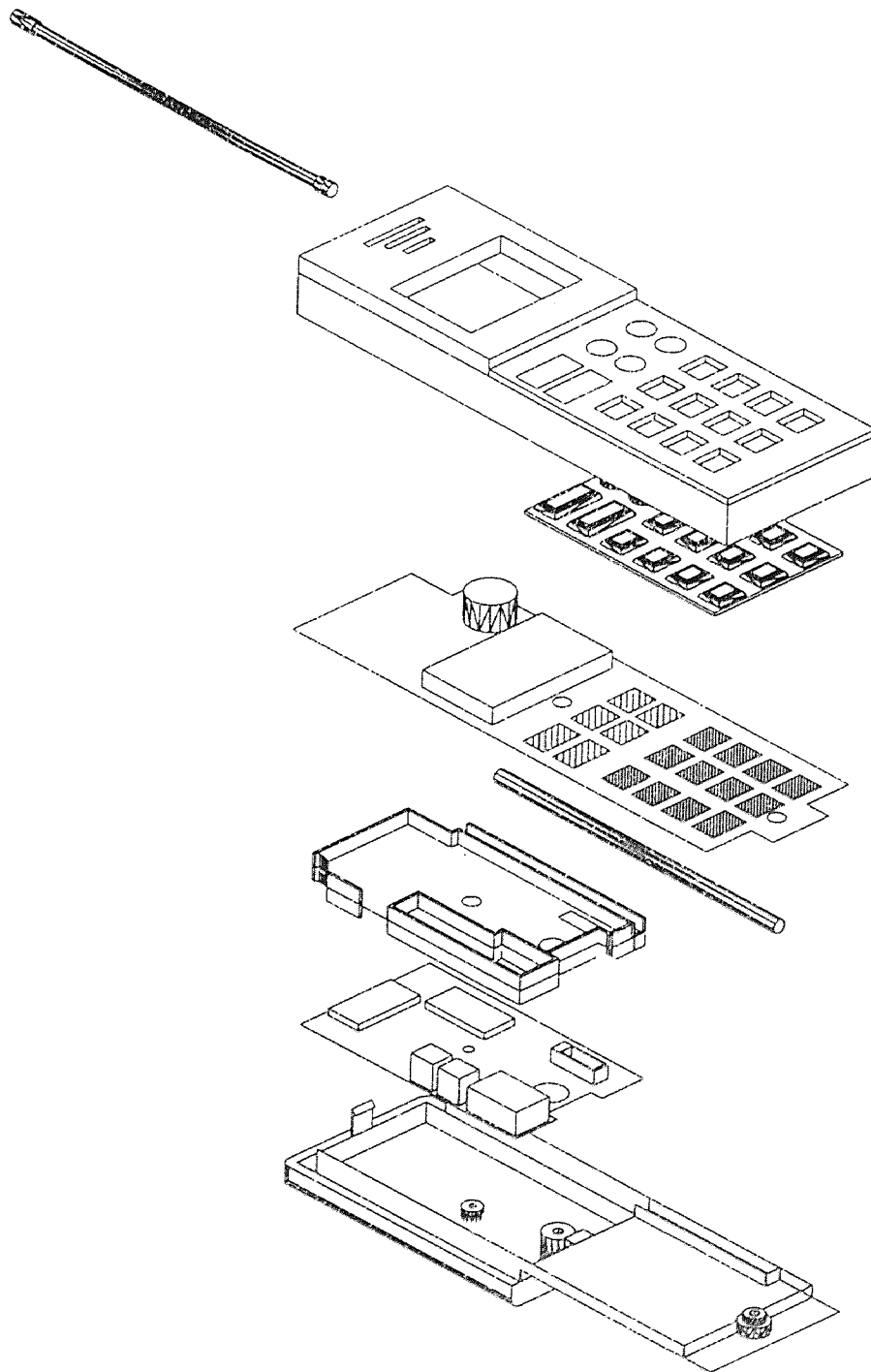

Figure 5.1 Assembly Drawing of a Cellular Phone

next. The large circuit is placed on the chassis. A single screw fastens the Upper circuit, chassis, lower housing and the smaller Circuit. The receiver is placed on the upper circuit and the leads are soldered to the Circuit. The upper face of the receiver is adhered to the upper housing. The antenna is slid into the upper housing and tightened by a screw. The LCD lens is placed on the upper housing and stuck to it. The keypad is placed on the large Circuit. The upper housing comes on the lower housing assembly and snaps on to it. Two screws are applied to the assembly, which completes the assembly process.

## **5.2 The DFQM Analysis and the QM Matrix**

The above explained are some of the major concerns in this design. The DFQM analysis was conducted on the assembly and the DFQM matrix was evolved.

### 5.2.1 Misplaced or Missing Parts

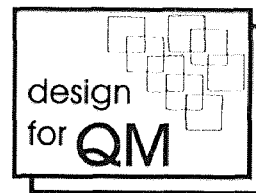

## Missing & Misplaced Defects Report

Design Name: Cellular Phone

Design Number:

Date: 12/08/97

### Maximum Error Catalyst Strength Matrix:

Part Name	Specific Defects			
	A1 Part Absent	A2 Misplaced	A3 Misposition	A Average
Lower Housing	0.00	0.00	0.00	0.00
Chassis	0.00	0.00	0.00	0.00
Upper Housing	0.00	0.00	0.00	0.00
Small CKT board	0.00	0.00	0.00	0.00
Large CKT board	0.00	0.00	0.00	0.00
Antenna	0.00	0.00	0.00	0.00
Keypad	0.00	<b>0.50</b>	<b>0.50</b>	<b>0.50</b>
LCD	0.00	0.00	0.00	0.00
LCD Lens	0.00	0.00	0.00	0.00
Plastic Outer Case	0.00	0.00	0.00	0.00
Microphone	0.00	0.00	0.00	0.00
Receiver	0.00	<b>0.50</b>	<b>0.50</b>	<b>0.50</b>

**Figure 5.2** QM matrix for Missing and Misplaced Defects Report

The results of DFQM analysis indicate that the following two parts have adverse QM score with reference to misplacement.

1. Keypad
2. Receiver

The assembly of the keypad causes quality problems as this part is flexible and it can be placed in any orientation and the assembly would continue without any hindrance.

The receiver is kept on the upper circuit board, soldered and then attached to the upper housing. There are no positioning elements that position the receiver on the upper circuit. The missing or misplacing of this part is inevitable if the assembly is done automatically.

### 5.2.2 Part Misalignment Defects of the Parts

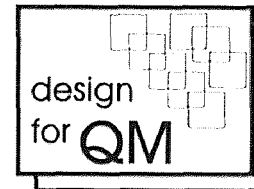

## Misalignments Defects Report

Design Name: Cellular Phone

Design Number:

Date: 12/08/97

*Maximum Error Catalyst Strength Matrix:*

<i>Part Name</i>	<i>Specific Defects</i>				<i>B</i> <i>Average</i>
	<i>B1</i> <i>Axial</i>	<i>B2</i> <i>Radial</i>	<i>B3</i> <i>Linear</i>	<i>B4</i> <i>Angular</i>	
Lower Housing	0.00	0.00	0.00	0.00	0.00
Chassis	0.00	0.00	0.00	0.00	0.00
Upper Housing	0.00	0.00	0.00	0.00	0.00
Small CKT board	0.00	0.00	0.00	0.00	0.00
Large CKT board	<b>0.50</b>	0.00	<b>0.30</b>	0.00	<b>0.50</b>
Antenna	0.00	0.00	0.00	0.00	0.00
Keypad	<b>0.50</b>	0.00	<b>0.50</b>	0.00	<b>0.50</b>
LCD	<b>0.50</b>	0.00	0.00	0.00	<b>0.50</b>
LCD Lens	0.00	0.00	0.00	0.00	0.00
Plastic Outer Case	0.00	0.00	0.00	0.00	0.00
Microphone	0.00	0.00	0.00	0.00	0.00
Receiver	<b>0.50</b>	0.00	0.00	0.00	<b>0.50</b>

**Figure 5.3** QM matrix for Misaligned defects report

The results of the DFQM analysis indicates that the following parts have an adverse QM score with reference to missing and misplacement:

1. The Large Circuit Board
2. The Keypad

### 3. The LCD

### 4. Receiver

The large Circuit board has a high score for part misplacement as there is only one positioning element on the lower housing at one end and the other end is free. The large Circuit board is plugged into a socket on the lower housing. As there are no positioning elements the chances for the part to be plugged-in in an undesirable manner are high.

The keypad being a flexible part does not have any clear positioning elements and the chance of misalignment of the keypad is also inevitable.

The LCD is a major concern, as this part is aligned at different locations. The LCD contains leads that protrude out at the bottom of the upper circuit. These leads are bent & soldered to make contact with the circuit wiring. The bending of the leads cannot be controlled and if one of the leads is bent more than necessary then misalignment of other leads is inevitable and there is no way this can be controlled.

As described above the receiver is placed on the upper circuit with no positioning elements and the chances for misalignment of the part is very high if not secured to the upper housing immediately. The receiver has two wires that are soldered to the circuit. This soldering cannot be achieved automatically, as the wires are not positioned. Manual soldering leads to quality defects in the assembly.



### 5.2.3. Part Interference Defects of the Parts

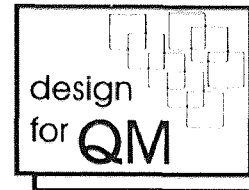

## Interference Defects Report

Design Name: Cellular Phone

Design Number:

Date: 12/08/97

### Maximum Error Catalyst Strength Matrix:

<i>Part Name</i>	<i>Specific Defects</i>			<i>C</i> <i>Average</i>
	<i>C1</i> <i>Constant</i>	<i>C2</i> <i>Occasional</i>	<i>C3</i> <i>Intermittent</i>	
Lower Housing	0.00	0.00	0.00	0.00
Chassis	0.00	0.00	0.00	0.00
Upper Housing	0.00	0.00	0.00	0.00
Small CKT board	0.00	0.00	0.00	0.00
Large CKT board	0.00	0.00	0.00	0.00
Antenna	0.00	0.00	0.00	0.00
Keypad	0.00	0.00	0.00	0.00
LCD	0.00	0.00	0.00	0.00
LCD Lens	0.00	0.00	0.00	0.00
Plastic Outer Case	0.00	0.00	0.00	0.00
Microphone	0.00	0.00	0.00	0.00
Receiver	0.00	0.00	0.00	0.00

**Figure 5.4** QM matrix for interference of parts

The DFQM analysis indicates that there is no part interference defects as there are no moving parts except for the antenna. The antenna does not interfere with any other part other than the tubing and the connector. The DFQM analysis does not foresee a quality defect due to this interference. Therefore the DFQM analysis does not give a score.

## 5.2.4 Fastener Related Defects

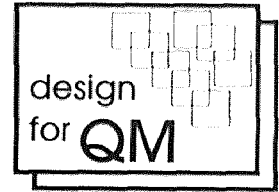

# Fastener Related Defects Report

Design Name: Cellular Phone

Design Number:

Date: 12/08/97

### Maximum Error Catalyst Strength Matrix:

<i>Part Name</i>	<i>Specific Defects</i>			<i>D</i> <i>Average</i>
	<i>D1</i> <i>Loose/Illfitted</i>	<i>D2</i> <i>Overtight</i>	<i>D3</i> <i>Fracture/Failure</i>	
Lower Housing	0.00	0.00	0.00	0.00
Chassis	0.00	0.00	0.00	0.00
Upper Housing	0.00	0.00	0.00	0.00
Small CKT board	0.00	0.00	0.00	0.00
Large CKT board	0.00	0.00	0.00	0.00
Antenna	<b>0.70</b>	0.00	0.00	<b>0.70</b>
Keypad	0.00	0.00	0.00	0.00
LCD	0.00	0.00	0.00	0.00
LCD Lens	0.00	0.00	0.00	0.00
Plastic Outer Case	0.00	0.00	0.00	0.00
Microphone	0.00	0.00	0.00	0.00
Receiver	0.00	0.00	0.00	0.00

**Figure 5.5** QM matrix for Fastener related defects report

The DFQM analysis show's that the fastener used to fasten the antenna has quality problems.

#### 1. Antenna

The fastener is put inside a slot in the upper housing and tightened. The fastener accessibility is very limited not only by the slot but also by the antenna itself which acts as an obstruction to the fastener. This inherent defect could cause loose or ill-fated fasteners and would finally lead to failure of the fastener.

The other places where fasteners are used are as follows. A single fastener is used to fasten the lower housing, lower Circuit, Chassis, and the upper Circuit board together. Finally two fasteners are used for final fastening.

### 5.2.5 Total Nonconformity of the Parts

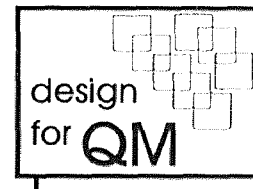

## Nonconforming Defects Report

---

Design Name: Door Handle

Design Number:

Date: 6/10/97

---

### *Maximum Error Catalyst Strength Matrix:*

<i>Part Name</i>	<i>Specific Defects</i>				<i>E</i>
	<i>E1</i>	<i>E2</i>	<i>E3</i>	<i>E</i>	
	<i>Dimensional</i>	<i>Design</i>	<i>Surface</i>		<i>Average</i>
Lower Housing	0.00	0.00	0.00		0.00
Chassis	0.00	0.00	0.00		0.00
Upper Housing	0.00	0.00	0.00		0.00
Small CKT board	<b>0.30</b>	0.00	0.00		<b>0.30</b>
Large CKT board	<b>0.30</b>	0.00	0.00		<b>0.30</b>
Antenna	0.00	0.00	0.00		0.00
Keypad	0.00	0.00	0.00		0.00
LCD	0.00	0.00	0.00		0.00
LCD Lens	0.00	0.00	0.00		0.00
Plastic Outer Case	0.00	0.00	<b>0.40</b>		<b>0.40</b>
Microphone	0.00	0.00	0.00		0.00
Receiver	0.00	0.00	0.00		0.00

---

**Figure 5.6** QM Matrix for Total non-conformity of parts

The DFQM analysis shows that the parts that have total nonconformity Quality defects are as follows.

1. Large Circuit Board
2. Smaller Circuit Board
3. Plastic Tubing

The two circuit boards draw a score because of their thin cross section. The circuits may get damaged during the fastening operation, which leads to the nonconformity of the boards.

The plastic tubing draws a score for nonconformity as the tube could bend due to the stress relaxation in the tube, so it may not stay in the groove with correct orientation at the time of assembly.

### 5.2.6 Damaged Parts Defects Reports

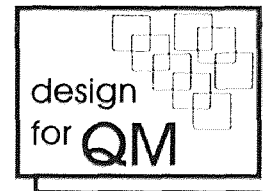

## Part Damage Defects Report

Design Name: Door Handle

Design Number:

Date: 6/10/97

### *Maximum Error Catalyst Strength Matrix:*

<i>Part Name</i>	<i>Specific Defects</i>		<i>F</i> <i>Average</i>
	<i>F1</i> <i>Physical</i>	<i>F2</i> <i>Aesthetic</i>	
Lower Housing	0.00	0.00	0.00
Chassis	0.00	0.00	0.00
Upper Housing	0.00	0.00	0.00
Small CKT board	<b>0.20</b>	0.00	<b>0.20</b>
Large CKT board	<b>0.20</b>	0.00	<b>0.20</b>
Antenna	0.00	0.00	0.00
Keypad	0.00	0.00	0.00
LCD	<b>0.60</b>	0.00	<b>0.60</b>
LCD Lens	0.00	0.00	0.00
Plastic Outer Case	0.00	0.00	0.00
Microphone	0.00	0.00	0.00
Receiver	0.00	0.00	0.00

**Figure 5.7** QM matrix for damaged parts

The DFQM analysis shows that the following parts could have this type of quality problem.

1. Large Circuit Board
2. Small Circuit Board
3. LCD

The Circuit boards have a high chance of damage during material handling and during assembly as they are made of thin cross-section.

The LCD draws a score because it is aligned at multiple areas, soldered at one place and bent at another place, due to different complex operations performed on the part, the part is prone to get damaged.

### 5.3 QM-Index Matrix Report

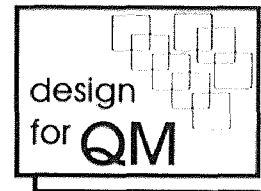

## QM-Index Matrix Report

Design Name: Door Handle

Design Number:

Date: 6/10/97

<i>Part Name</i>	<i>Defect Classes</i>					
	<i>A</i> <i>Missing &amp; Misplaced</i>	<i>B</i> <i>Misaligned</i>	<i>C</i> <i>Part Interference's</i>	<i>D</i> <i>Fastener Problems</i>	<i>E</i> <i>Parts Nonconforming</i>	<i>F</i> <i>Physical Damage</i>
Lower Housing	0.00	0.00	0.00	0.00	0.00	0.00
Chassis	0.00	0.00	0.00	0.00	0.00	0.00
Upper Housing	0.00	0.00	0.00	0.00	0.00	0.00
Small CKT board	0.00	0.00	0.00	0.00	<b>0.30</b>	<b>0.20</b>
Large CKT board	0.00	<b>0.50</b>	0.00	0.00	<b>0.30</b>	<b>0.20</b>
Antenna	0.00	0.00	0.00	<b>0.70</b>	0.00	0.00
Keypad	<b>0.50</b>	<b>0.50</b>	0.00	0.00	0.00	0.00
LCD	0.00	<b>0.50</b>	0.00	0.00	0.00	<b>0.60</b>
LCD Lens	0.00	0.00	0.00	0.00	0.00	0.00
Plastic Outer Case	0.00	0.00	0.00	0.00	<b>0.40</b>	0.00
Microphone	0.00	0.00	0.00	0.00	0.00	0.00
Receiver	<b>0.50</b>	<b>0.50</b>	0.00	0.00	0.00	0.00

**Figure 3.8** QM Index matrix Report

There are many inherent quality defects in the design of the cellular phone. The Major Quality concerns are listed below.

The LCD is aligned at multiple points with no positioning elements.

The microphone is assembled with a multiple axis assembly and it has flexible parts that do not maintain position. The Microphone is assembled in the following manner, microphone is brought on to the upper circuit in a negative Z-axis and positioned, but the leads are not positioned and they are soldered at the bottom of the upper circuit. This requires the circuit to be turned upside down and soldered manually by hand.

One other major draw back is that the plastic tube is positioned before the antenna slides through. The plastic tube is placed in a groove in-between the lower assembly and the chassis. The placing of this part is a major concern as being a flexible part placed in a groove with no space for any additional movement of the grippers to release the part. Therefore the assembly can be done only manually.

#### **5.4 Design Changes Based on the DFQM Scores**

The defect caused by the leads of the LCD can be avoided if the leads have a female mating partner in the Large Circuit. This eliminates the necessity of bending the leads at the right length and ensuring a good contact is made.

The design of the microphone can be modified such that the microphone has solid leads instead of lead wires.

The design of the upper housing can be changed such that the screw is outside the groove instead of inside a groove. Or the fastener can be an integral part of the antenna. This would increase the accessibility of the fastener and reduce its DFQM score.

Introducing snaps on the lower and upper housing can reduce the number of fasteners in the assembly. These snaps also act as positioning elements for the large circuit and reduce the score for misalignment.

The receiver instead of welding on to the large Circuit it can be held in position by leads that are in a cantilever shape. Then the receiver can be stuck on to the upper housing and when the upper housing is brought down on to the lower housing the contact of the receiver is made with the circuit.

The keypad being a flexible part nothing much can be done to the design due to the nature of the part.

The plastic tubing instead of placing it separately can be integrated with the antenna there by reducing the number of individual parts in the assembly.



## Chapter 6

### Conclusions and Future Research

#### 6.1 Conclusions

DFQM methodology attempts to create a definite relationship between the design, manufacturing and the quality of the product. As seen in this thesis analyzing each and every feature of the design and assembly process exposes the strengths and weaknesses in the quality of the design. The quality deficiencies are presented in the form of a distinct pattern of functional dependencies between the influencing factors (through influencing factors, error catalysts and specific defects) and Defect classes. In this thesis, work conducted by Thamboo (1994), Ramachandra (1994), Dhar (1995), Gami (1996) and Datla (1997) is extended by the addition of new error catalysts and revision of the charts i.e., Functional, positional and fastener charts as shown in the appendix. This thesis further tests the software created by Datla (1997) and validates the result. Inputting completely different designs and getting response from the software did the testing of the software.

With the conclusion of this work the applicability of the DFQM technique and the software is tested and also its scope has been increased by the addition of new error catalysts. This work has been the polishing and debugging of the DFQM schema and the software.

## **6.2 Computerized DFQM Analysis**

We computerized the DFQM technique, computerization was a very important step in the actual implementation of the technique in industry. The DFQM process is quite laborious and time consuming if done manually, as each error catalyst analyzes each part and gives out a score and these scores must be formatted into the QM matrix to get a comprehensive look on the Design. In this thesis the actual assemblies were inputted into the software and a QM matrix was evolved and also these designs were compared manually. This resulted in validating the software and also analyzing the designs using the DFQM technique.

## **6.3 Future Work**

The scope of the thesis is limited to the addition of new error catalysts and analyzing the mechanical and Electro-mechanical designs using the DFQM technique both manually and using the software. This thesis work is the mathematical and software verification of DFQM technique. In immediate future the software intelligence has to be increased there by the software is much more user friendly and much simpler to use.

Extended research plans could include integration of CAD packages like ProEngineer into the DFQM methodology so that there would not be a necessity for inputting the Geometry inputs at all into the methodology.

# APPENDIX A

## DFQM ARCHITECTURE

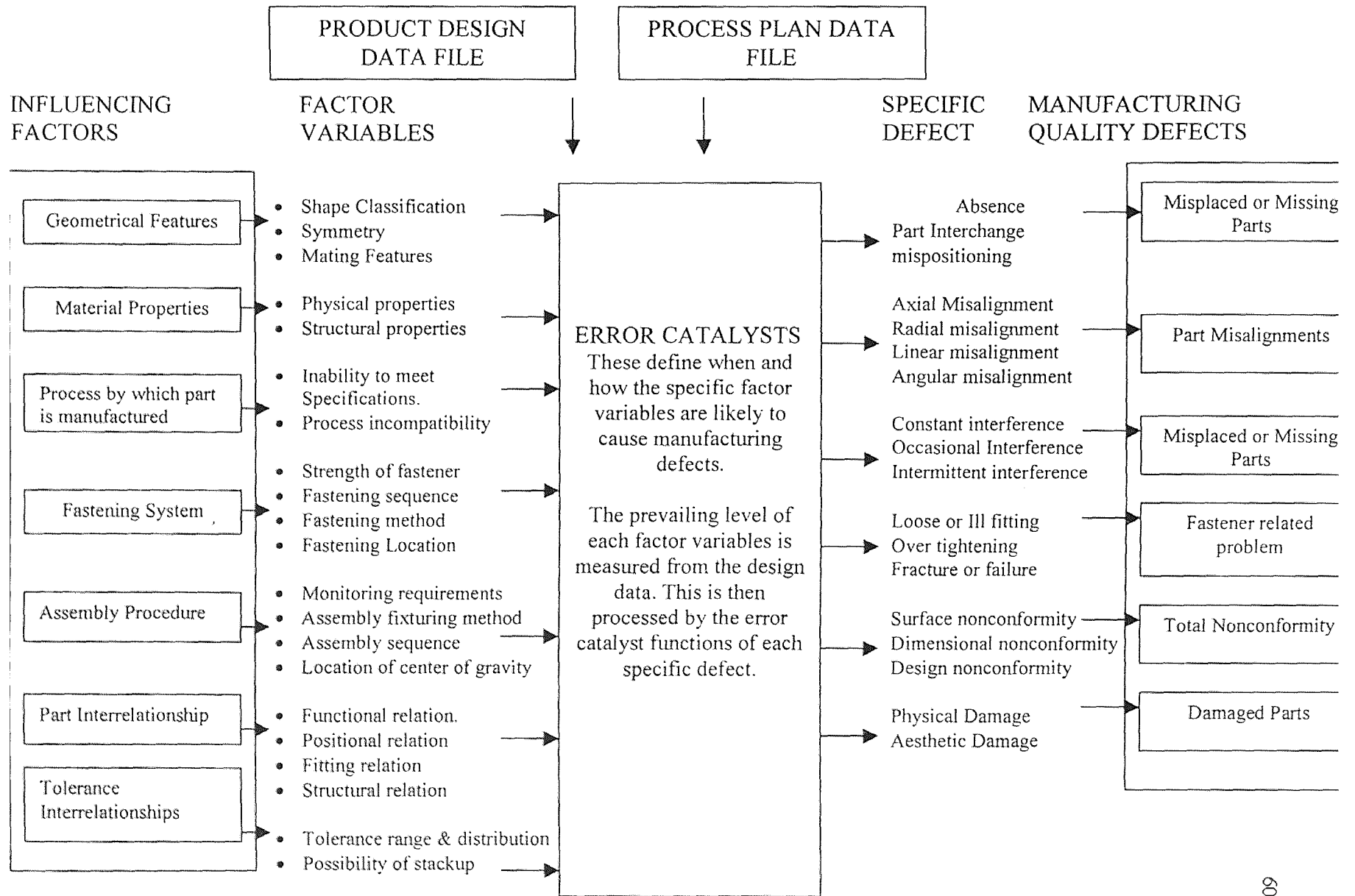

# APPENDIX B

## FASTENER CHART

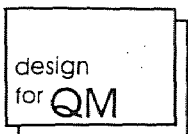

	Dir. Of Separation Force	Force Mapping Ratio	Fastener Accessibility	Fastener Spacing
	A	B	C	D
1	<p>Parallel to fastening axis</p>	<p><math>0 &lt; \text{FMR} &lt; 0.25</math></p> <p>Fastener Location</p>	<p>Access from 5 directions</p>	<p>Constant with a pattern</p>
2	<p>Perpendicular to fastening axis</p>	<p><math>0.25 &lt; \text{FMR} &lt; 0.50</math></p>	<p>Access from 4 directions</p>	<p>Varying with a pattern</p>
3	<p>Eccentric to fastening axis</p>	<p><math>0.50 &lt; \text{FMR} &lt; 0.75</math></p>	<p>Access from 3 directions</p>	<p>Varying with no pattern</p>
4		<p><math>0.75 &lt; \text{FMR} &lt; 1.00</math></p>	<p>Access from 2 directions</p>	
5			<p>Access from 1 direction</p>	

# APPENDIX C

## POSITIONAL CHART

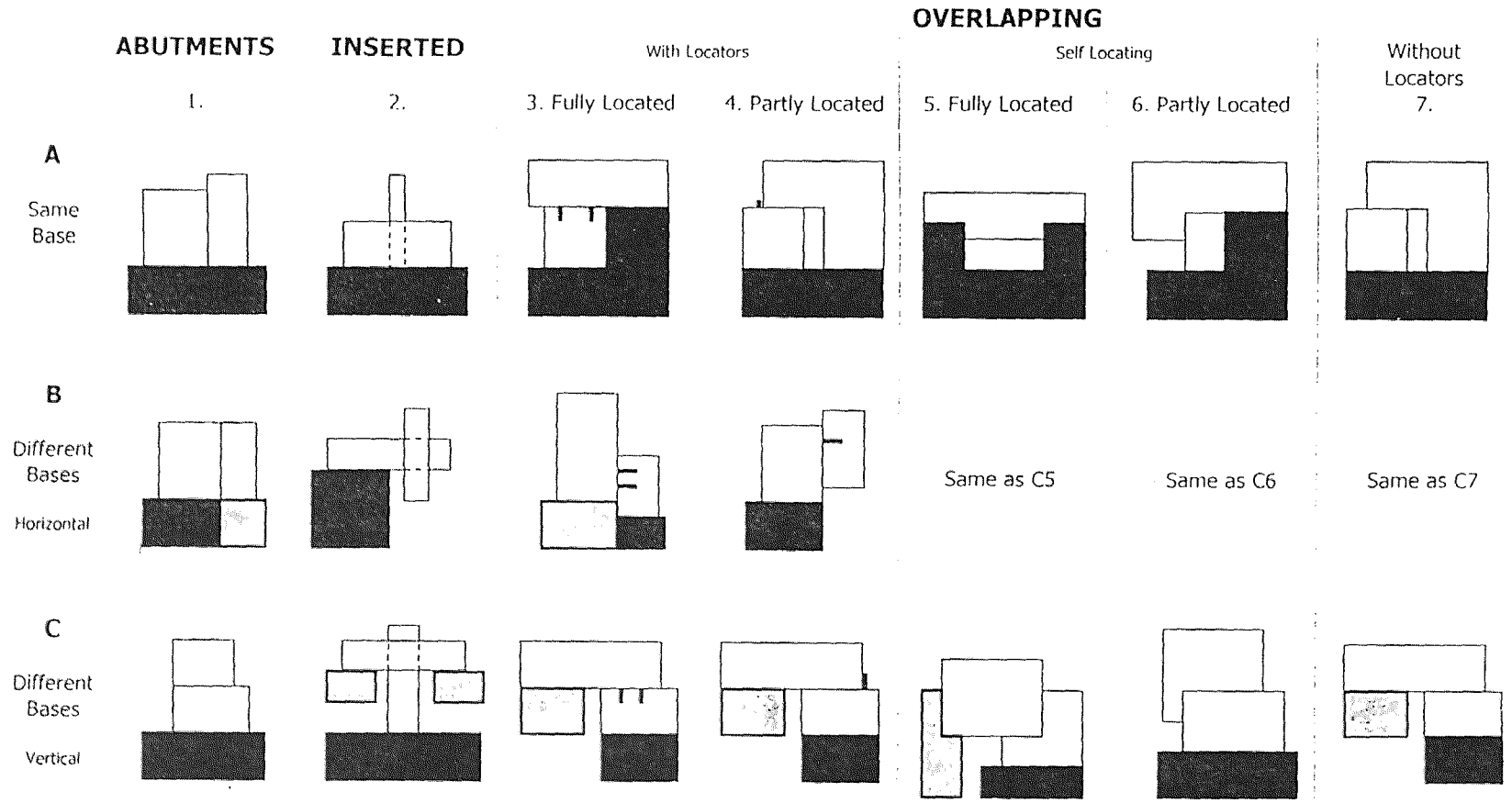
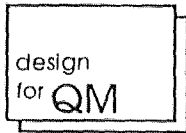

APPENDIX D

FUNCTIONAL RELATIONSHIP CHART



Appendix D

Physical Support

Connective

Limiting or Guiding

A

B

C

1  
No Motion

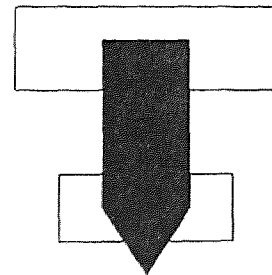
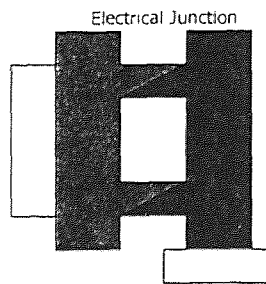
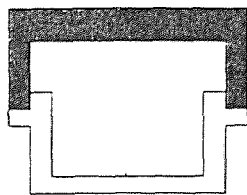

2  
Joint Motion

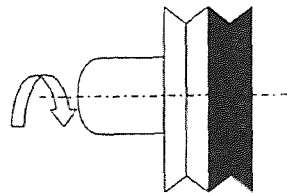
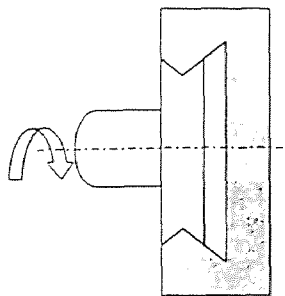

Same as C1

3  
Relative Motion

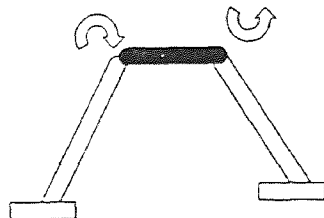

Car Door Lock

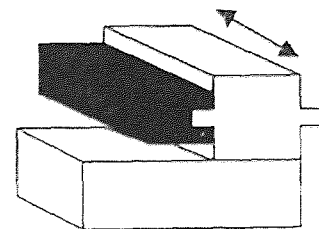
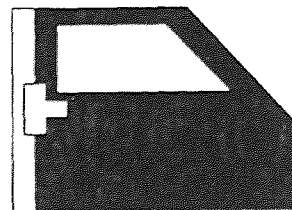

## REFERENCES

- Abdel-Malek, L. "A case study on the use of robots in assembly processes" *Engineering Costs and Production Economics*, 9(1985): 99-103
- Boothroyd, G. and Dewhurst, P. *Product Design for Assembly Handbook* Walefield, Rhode Island: Boothroyd-Dewhurst Inc., 1987.
- Boothroyd, G. and Dewhurst, P. and Knight, W. *Product Design for Manufacture and Assembly* University of Rhode Island, Kingston, Rhode Island: Marcel Decker, Inc., 1994.
- Ceglarek, D. and Shi, J. "Dimensional Variation Reduction for Automotive Body Assembly" *Manufacturing Review*, 8(1995): 139 – 154.
- Das, S. "Design for Quality Manufacturability: An approach for improving the quality of assembled products:" *IIE Transactions*, June 1993.
- Deitz, D. "Design for Quality Control" *Mechanical Engineering*, 6(1995): 60-65
- Deming, W. *Out of crisis* Cambridge, Massachusetts: MIT Center for Advanced Engineering Study, 1986.
- G. Bengu, B.Prasad, A.Dhar "Multi-Agent Based Cooperative Framework to support Concurrent Engineering." *Proceedings CERA, First International Conference on Concurrent Engineering*. Pittsburgh PA August 1994.
- D. Daetz "The Effect of Product Design on Product Quality and Product cost." *Quality Progress*. PP 63-67. June 1987.
- S.Prasad. "Design for Quality Manufacturability: Formulation of MacroArchitecture for DFQM methodology." *Masters Thesis. New Jersey Institute of Technology*. Newark, NJ, December 1994.
- Suryanarayana,Ramachandra. "Design for Quality Manufacturability of Common Assembly Processes." *Masters Thesis. New Jersey Institute of Technology*. Newark, NJ, December 1994.
- Abhinav, Dhar, "Analysis of a design for its quality Manufacturability in terms of misalignments and fastener related problems" *Masters Thesis. New Jersey Institute of Technology*. Newark, NJ, December 1995.

- Gami, Samir R., "Design for Quality Manufacturability analysis of the Total nonconformity damaged parts". *Masters Thesis. New Jersey Institute of Technology*, Newark, NJ,. December 1996.
- Vikram.V.Datla., "Design Improvement using reverse analysis in Design for Quality Manufacturability." *Masters Thesis. New Jersey Institute of Technology*. Newark, NJ, January 1997.
- Altaf Y, Thamboo. " Design for Quality Manufacturability Analysis of Missing/ Misplaced Parts and Part Interference." *Masters Thesis. New Jersey Institute of Technology*. Newark, NJ, December 1995.
- N. Suh, A.Bell and D. Gossard "On an Axiomatic Approach to Manufacturing and Manufacturing Systems." *ASME Journal of Engineering for Industry*. 100.2, pp 127-130. 1978.
- Shingley, J. *Mechanical Engineering Design*. 1 st. ed. NY: McGraw-Hill Book Company, Inc., 1963.
- Stoll, H. "Design for Manufacture" *Manufacturing Review*, January (1988):23-29.
- Taguchi, Genichi. "*Introduction to Quality Engineering*". Tokyo: Asian Productivity Organization, 1986.