

## **Copyright Warning & Restrictions**

The copyright law of the United States (Title 17, United States Code) governs the making of photocopies or other reproductions of copyrighted material.

Under certain conditions specified in the law, libraries and archives are authorized to furnish a photocopy or other reproduction. One of these specified conditions is that the photocopy or reproduction is not to be “used for any purpose other than private study, scholarship, or research.” If a user makes a request for, or later uses, a photocopy or reproduction for purposes in excess of “fair use” that user may be liable for copyright infringement,

This institution reserves the right to refuse to accept a copying order if, in its judgment, fulfillment of the order would involve violation of copyright law.

**Please Note: The author retains the copyright while the New Jersey Institute of Technology reserves the right to distribute this thesis or dissertation**

Printing note: If you do not wish to print this page, then select “Pages from: first page # to: last page #” on the print dialog screen

The Van Houten library has removed some of the personal information and all signatures from the approval page and biographical sketches of theses and dissertations in order to protect the identity of NJIT graduates and faculty.

## **ABSTRACT**

### **IMPLEMENTATION OF A FRICTION ESTIMATION AND COMPENSATION TECHNIQUE**

**by  
Jayesh N Amin**

This thesis reports implementation of a friction estimation and compensation technique on a special laboratory apparatus. In this work, experimental results are reported for the Coulomb friction observer.

The Coulomb friction observer estimates the total friction present in a system, assuming it to be a constant function of velocity. An extension of the observer, utilizing a coupled velocity observer, is used when velocity is not measurable. A modification to the velocity observer is also implemented. Experimental results show a remarkable improvement in the friction estimates which are also compared to the actual friction measurements. The estimates are qualitatively similar to the actual friction, demonstrating the ability of the modified design to track a non-constant friction.

Finally, extremely low velocities are experimentally obtained by using the friction compensation technique mentioned above, further proving that accurate control at low velocities is possible by friction estimation and compensation.

**IMPLEMENTATION OF A FRICTION ESTIMATION  
AND COMPENSATION TECHNIQUE**

**by  
Jayesh N Amin**

**A Thesis  
Submitted to the Faculty of  
New Jersey Institute of Technology  
in Partial Fulfillment of the Requirements for the Degree of  
Master of Science in Electrical Engineering**

**Department of Electrical and Computer Engineering**

**January 1996**

APPROVAL PAGE

IMPLEMENTATION OF A FRICTION ESTIMATION  
AND COMPENSATION TECHNIQUE

Jayesh N Amin

---

Dr. Bernard Friedland, Thesis Advisor  
Distinguished Professor of Electrical Engineering, NJIT

Date

Dr. Avraham Harnoy, Committee Member  
Professor of Mechanical Engineering, NJIT

Date

Dr. Timothy Chang, Committee Member  
Assistant Professor of Electrical Engineering, NJIT

Date

## BIOGRAPHICAL SKETCH

**Author:** Jayesh N Amin  
**Degree:** Master of Science in Electrical Engineering  
**Date:** January 1996

### **Undergraduate and Graduate Education:**

- Master of Science in Electrical Engineering,  
New Jersey Institute of technology, Newark, NJ, USA, 1996
- Bachelor of technology in Electrical and Electronics Engineering,  
Indian Institute of Technology, Madras, India, 1994

**Major:** Electrical Engineering

This thesis is dedicated to  
my mom, dad, mota and moti who I missed  
so much in the past one year

## ACKNOWLEDGMENT

I wish to express my sincere gratitude to my advisor, Distinguished Professor Bernard Friedland, for his guidance and moral support throughout this research work. I would like to thank him for all the help he provided in carrying out the project smoothly.

Special thanks to Professor Avraham Harnoy for guiding me through the research and for serving as a committee member. Thanks also to Professor Timothy Chang for serving as a member of my thesis committee.

I am also grateful to the Department of Electrical and Computer Engineering for providing me with full support during the research and Department of Mechanical Engineering for providing the facilities and apparatus for the experiments.

I wish to acknowledge the help and support from the Dynamic Systems Laboratory team, including Hanuman Rachoor and Richard Semenock for all the help and support they provided. Appreciations are also due to the Control Systems Laboratory, particularly David Hur for helping me out with the components and references required during the research.

Finally, I would like to extend my thanks to my family for all the love they have given me so far and which has helped me get through all these years.



## TABLE OF CONTENTS

Chapter	Page
1 INTRODUCTION . . . . .	1
2 AN OVERVIEW OF THE FRICTION PHENOMENON . . . . .	3
2.1 Classical Friction Model . . . . .	3
2.2 Friction as a Function of Velocity . . . . .	5
2.3 Modern Mathematical Models of Friction . . . . .	6
2.3.1 Static Friction Models . . . . .	7
2.3.2 Dynamic Friction Models . . . . .	9
3 METHODS OF FRICTION COMPENSATION . . . . .	15
3.1 Classification of Compensation Techniques . . . . .	15
3.2 Problem Avoidance . . . . .	16
3.3 Non-model Based Friction Compensation . . . . .	17
3.4 Model Based Friction Compensation . . . . .	21
4 COULOMB FRICTION ESTIMATION AND COMPENSATION . . . . .	25
4.1 Problem Definition . . . . .	25
4.2 Observer Dynamics . . . . .	27
4.2.1 Coulomb Friction Observer - Original Form . . . . .	27
4.2.2 Extension of the Coulomb Friction Observer . . . . .	30
4.2.3 Modification to the Velocity Observer . . . . .	32
4.3 Study Performed in this Thesis . . . . .	34
5 IMPLEMENTATION OF THE COULOMB FRICTION OBSERVER . . . . .	35
5.1 Experimental Apparatus . . . . .	35
5.2 System Identification and Control Design . . . . .	38
5.3 Observer Algorithms . . . . .	40
5.4 Control with Friction Compensation . . . . .	42
5.5 Experimental Results . . . . .	42
5.5.1 Position Control Experiments . . . . .	43
5.5.2 Velocity Control Experiments . . . . .	44

**TABLE OF CONTENTS**  
**(Continued)**

<b>Chapter</b>	<b>Page</b>
5.5.3 Very Low Velocity Experiments .....	46
6 CONCLUSIONS AND FUTURE WORK .....	60
APPENDIX .....	61
REFERENCES .....	69

## LIST OF FIGURES

Figure	Page
2.1 Classical friction models (a) Static + Coulomb friction model, (b) Static + Coulomb + Viscous friction model and (c) Static + Viscous + Stribeck friction model (friction versus velocity plots). . . . .	4
2.2 Stribeck friction characteristic - Regime of lubrication. (I) Pre-sliding deformation, (ii) Boundary lubrication, (iii) Partial fluid lubrication and (iv) Full fluid lubrication. . . . .	6
4.1 Coulomb Friction Observer - as proposed in its original form. This form assumes availability of measured velocity. . . . .	28
4.2 Coulomb Friction Observer - Extended form. This form uses a coupled velocity observer and does not need measurable velocity. . . . .	31
5.1 Photograph of the experimental apparatus. . . . .	36
5.2 Cross-section of the friction measuring apparatus . . . . .	36
5.3 Actual and modeled system step response . . . . .	39
5.4 Position control experiments - Square wave reference (i) Actual and reference position without friction compensation (ii) with friction compensation (iii) position error without compensation (iv) with compensation (v) estimated friction coefficient in time (vi) estimated friction v/s velocity. . . . .	48
5.5 Position control experiments - Triangular wave reference (i) Actual and reference position without friction compensation (ii) with friction compensation (iii) position error without compensation (iv) with compensation (v) estimated friction coefficient in time (vi) estimated friction v/s velocity. . . . .	49
5.6 Position control experiments - Sinusoidal wave reference (i) Actual and reference position without friction compensation (ii) with friction compensation (iii) position error without compensation (iv) with compensation (v) estimated friction coefficient in time (vi) estimated friction v/s velocity. . . . .	50
5.7 Velocity control experiments - Square wave reference (i) Actual and reference velocity without friction compensation (ii) with friction compensation (iii) velocity error without compensation (iv) with compensation. . . . .	51

**LIST OF FIGURES**  
(Continued)

Figure	Page
5.8 Velocity control experiments - Triangular wave reference (i) Actual and reference velocity without friction compensation (ii) with friction compensation (iii) velocity error without compensation (iv) with. ....	52
5.9 Velocity control experiments - Sinusoidal wave reference (i) Actual and reference velocity without friction compensation (ii) with friction compensation (iii) velocity error without compensation (iv) with. ....	53
5.10 Estimated friction and measured friction for unidirectional velocity (i) estimated friction and (ii) measured friction for freq = 0.1 rad/sec (iii) estimated friction and (iv) measured friction for freq = 0.5 rad/sec. ....	54
5.11 Estimated friction and measured friction for bidirectional velocity (i) estimated friction and (ii) measured friction for freq = 0.1 rad/sec (iii) estimated friction and (iv) measured friction for freq = 0.5 rad/sec. ....	55
5.12 Estimated friction and measured friction (i) estimated friction and (ii) measured friction for freq = 1 rad/sec (iii) estimated friction and (iv) measured friction for bi-directional variations for freq = 1 rad/sec. ....	56
5.13 Very low velocity control experiments - Square wave reference (i) reference and actual velocity without friction compensation (ii) with friction compensation (iii) velocity error without compensation (iv) with compensation. ....	57
5.13 Very low velocity control experiments - Triangular wave reference (i) reference and actual velocity without friction compensation (ii) with friction compensation (iii) velocity error without compensation (iv) with compensation. ....	58
5.13 Very low velocity control experiments - Sinusoidal wave reference (i) reference and actual velocity without friction compensation (ii) with friction compensation (iii) velocity error without compensation (iv) with compensation. ....	59

# CHAPTER 1

## INTRODUCTION

Friction plays an important role in our everyday life. Without friction, it would be extremely inconvenient to produce any motion. However, it is the same friction that contributes to difficulties in producing very precise motion.

This thesis discusses implementation of a friction estimation and compensation technique which allows us to obtain very high accuracy in motion control. Various mathematical models of friction are available in the literature. The technique of this thesis is the Coulomb model for friction: Friction is estimated using a Coulomb friction observer which assumes friction to be a constant function of velocity but whose direction depends upon the direction of the velocity. The friction thus estimated is compensated or canceled by applying an equal amount of torque or force in the opposite direction. A good estimate of friction makes it a very near perfect cancellation and the system behaves like a frictionless system. The system thus compensated, can then be very accurately controlled by applying any of the popular control techniques.

The above mentioned Coulomb friction observer requires availability of the measured velocity. However, in many practical systems, velocity is not available for direct measurement. Hence, an extension to the Coulomb friction observer is applied which uses another coupled velocity observer to estimate velocity from the measured position. Experimental results are presented for both the position and the velocity control systems.

Experimental results presented in recent literature (Tafazoli et al., 1995) demonstrated a poor performance of the velocity observer as used in its original form and a modification to the observer was proposed. This thesis also reports implementation and verification of the better performance of the Tafazoli modification to the observer. In addition, this thesis reports a remarkable improvement in the friction estimate by using the modification. The friction estimates for various frequencies of variation are compared to the physically measured friction. For the first time, the friction observer based on the Coulomb model of friction is shown to be capable of tracking the Stribeck friction and capturing the hysteresis effects. The estimates compare well with the measured friction. Finally, very low velocity control is implemented and creeping velocities are obtained by using the above technique.

In Chapter 2, we present a brief overview of the friction models reported in literature. It deals with the evolution of our understanding of friction with the availability of experimental results. Chapter 3 covers the various techniques applied by engineers today to deal with friction. Chapter 4 deals exclusively with the Coulomb friction observer, which is utilized in this thesis. It also introduces the extension and modification to the Coulomb friction observer. Chapter 5 presents the important experimental results. It describes implementation of the position and velocity controls and also compares the friction estimate with the actual friction measurements. Finally, Chapter 6 explains the experimental results and presents some conclusions. It also suggests some future work on the topic.

## CHAPTER 2

### AN OVERVIEW OF THE FRICTION PHENOMENON

The phenomenon of friction has never deserved as much attention as it does now. With the amount of precision expected from the present day control systems, there has been a need for a clearer understanding of friction.

Friction is present when two parts in contact move relative to each other. For certain cases friction could be an advantageous property, as it is for brakes, but for precise motion control it is a problem that needs to be taken care of. Over the years, engineers from widely varying fields have contributed to the understanding of friction. A survey paper by Armstrong-Hélouvy et al. (1994) is a good source for references to these studies. It presents a comprehensive study of various friction models and compensation techniques currently existing among the engineering community.

#### 2.1 Classical Friction Model

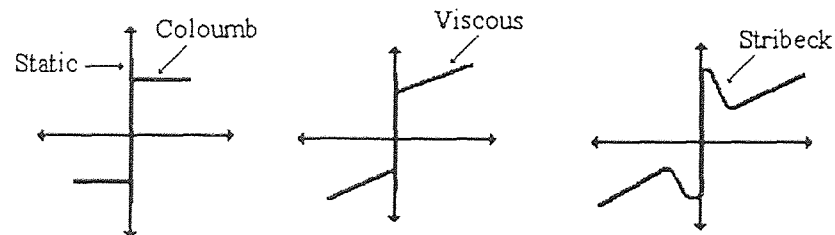
The most important step in identifying and solving a problem in engineering design is that of developing an analytical model which explains as truly the actual physical observations as possible.

Perhaps the first systematic model for friction was proposed by Leonardo Da Vinci which is now considered as the Coulomb friction model. This concept of friction evolved into what is now known as the classical model of friction. Leonardo Da Vinci's friction laws can be defined as follows

The friction force

- acts in the direction opposite to that of motion,
- is proportional to load and
- is independent of the area of contact.

Da Vinci's understanding remained hidden for a long time before it was rediscovered by Amontons (1699) and developed by Coulomb (1785) and others. The concept of static friction was introduced by Morin (1833) and Reynolds (1886) introduced the equation of viscous fluid flow. These evolved the most commonly used model in engineering: the static + Coulomb + viscous friction model (Morin, 1833; Reynolds, 1886). Figure 2.1 displays the evolution of the classical friction model.



**Figure 2.1** Classical friction models (a) Static + Coulomb friction model, (b) Static + Coulomb + Viscous friction model and (c) Static + Viscous + Stribeck friction model (friction versus velocity plots).

The field which deals particularly with the study of the friction properties has come to be known as tribology. The main interest of a tribologist is to better understand the wear caused by the friction in moving parts. They strive to develop better lubricants towards reducing friction by studying the surface topographies and interactions.



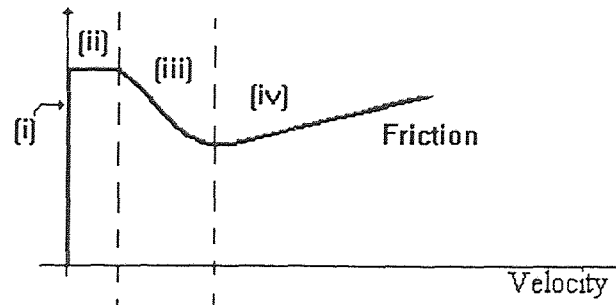
However, a control engineer is interested in the dynamic behavior of friction which can be readily incorporated into design calculations. It is very important to have the dynamics represented in form of mathematical models. In recent years, many such models of friction have been proposed. Experimental results have been utilized to define empirical friction models. The models have evolved along with the experimental results. A completely theoretically-derived model has yet to be developed, although efforts for developing such models are in progress (Harnoy et al., 1994). As the experiments grew progressively more sensitive and newer phenomenon became available, newer and more complex friction models were developed to explain these new observations.

## **2.2 Friction as a Function of Velocity**

While defining friction, an important characteristics to be considered is the variation of friction with velocity. In fact, most friction models define friction as a nonlinear function of velocity. As understood now, there are four different but not necessarily exclusive regimes of lubrication as the machine accelerates away from zero velocity. The lubrication concepts involved are explained in detail in Armstrong-Hélouvy (1994). Figure 2.2 shows these regimes and is called the Stribeck curve (Stribeck, 1902; Biel, 1920; Czichos, 1978).

These are the dynamics that a controller has to confront for motion control. The first regime is called the static friction or elastic deformation. It basically involves the presliding displacement. In this region, friction acts more like a spring constraint. The

second and third regimes are the boundary and the partial-fluid lubrication regions where in most cases, friction characteristic shows a negative slope. This is the main destabilizing element which a control engineer has to address. The fourth regime represents the viscous friction which is caused after full-fluid lubrication. Viscous friction, in general, does not cause any stability problems.



**Figure 2.2** Stribeck friction characteristic - Regimes of lubrication. (i) Pre-sliding deformation, (ii) Boundary lubrication, (iii) Partial fluid lubrication and (iv) Full fluid lubrication.

### 2.3 Modern Mathematical Models of Friction

In the literature, various models have been proposed by researchers to explain the observed nature of friction. Earlier models were developed based on the static observations and did not include the “memory” effects. These models were mainly deviants of the classical friction model but most tried to incorporate the negative slope observed in the friction characteristics. However, as experiments were made more sensitive and accurate, they indicated a presence of memory effect in friction. In fact, the change in friction lags behind the changes in velocity and this delay was demonstrated by experimental results (Sampson *et al.*, 1943; Rabinowicz, 1958, 1965;

Bell and Burdekin, 1966, 1969; Rice and Ruina, 1983; Hess and Soom, 1990; Polycarpou and Soom, 1992). These observations inspired the developments of new models which included the dynamic behavior of friction.

### 2.3.1 Static Friction Models

We distinguish the term “static” used here from the customary usage of the term. Here, static refers to the way velocity is considered while characterizing the friction. In the static models, it is assumed that friction is an instantaneous function of velocity and hence, does not depend on how the velocity was varied to reach that value. This was the character of friction which was generally believed to be true until the experimental results proved otherwise.

The first and the simplest static model to be proposed was the Coulomb friction model which is represented as

$$F = a \operatorname{sgn}(v)$$

where  $F$  is the friction force,  $v$  is the velocity and  $a$  is the magnitude of friction which is generally proportional to the normally applied force  $F_n$

$$a = cF_n$$

where  $c$  is called the coefficient of friction. In this research work, we will be using the Coulomb model of friction in which the parameter  $a$  is to be estimated. Actually  $c$  is the unknown parameter in the model but we assume that the normal force  $F_n$  is also unknown (which is usually the case) and hence we try to estimate the magnitude of the friction force  $a$ .

The next modification that was considered was to include the negative friction in the model. Tustin (1947) attempted to account for the negative slope by assuming friction to be exponentially decaying from a value of highest static friction to a lower value of kinetic friction. He proposed a friction model of the form

$$F = [F_k + (F_s - F_k)e^{-v/v_c}] \text{sgn}(v)$$

Where  $F_s$ ,  $F_k$  and  $F$  stand for static, kinetic, and total friction, respectively, and  $v$  and  $v_c$  is the velocity and the velocity when kinetic friction occurs. This model included the phenomenon of negative friction and hence can explain the limit cycle oscillations observed in systems with friction.

Another model with a similar exponential characteristics was proposed by Bo and Pavulescu (1982) and is given by

$$F = [F_k + (F_s - F_k)e^{-(v/\alpha)^n}] \text{sgn}(v)$$

In this model, the parameters are the variables  $\alpha$  and  $n$ . For practical systems,  $n$  is found to be in the range from 0.5 to 1.0. However,  $n$  was suggested to be very large by Fuller (1984) for systems with effective lubrication.

In an attempt to find parameters in Tustin's model to fit experimental results for a brush type dc servo motor mechanism with bearing, Armstrong-Hélouvry (1991) found parameter values to be  $F_s = 9.56$ ,  $F_s - F_k = 1.13$  and  $v_c = 0.019$ . He also examined several other available models to fit the experimental results and to account for the negative friction (Stribeck effect). The models he used were Tustin's model, a Gaussian model, a Gaussian model with offset, a Lorentzian model as proposed by Hess and Soom and a polynomial model. He also used the Bo and Pavulescu model with  $n = 2$

and  $\alpha$  to be 0.0053 or 0.035 for compliant motion. The friction models mentioned above can be mathematically represented in the following way

Tutsin's model	$(F_s - F_k)e^{-v/v_s}$
Gaussian model	$(F_s - F_k)e^{-(v/v_s)^2}$
Gaussian model with offset	$(F_s - F_k)e^{-((v-v_o)/v_s)^2}$
Lorentzian model	$(F_s - F_k) \frac{1}{1 + (v/v_s)^2}$

### 2.3.2 Dynamic Friction Models

Dynamic friction models essentially capture the concept of lag in friction variation with variation in velocity. These models incorporate the “memory” of the velocity history to account for the hysteresis observed in experimental results. Evidence for frictional memory is available from a range of experimental sources: Sampson et al. (1943), Rabinowicz(1958, 1965), Bell and Burdekin (1966, 1969), Walrath (1984), Rice and Ruina (1983), Hess and Soom (1990).

These dynamic models can be classified into two main categories from the view of a control engineer, viz. those in the state space form and those which are not in the state space form. Mentzelopoulou (1994) presents this classification of models in a comprehensive manner.

First we will have a brief review of the models which are available in other than the standard state space form.

After the experimental results demonstrating the “memory” effect in the friction were reported, Kato et al. (1972, 1974) proposed a model to account for the time dependence in the friction characteristics. Their model is given mathematically by:

$$F_s(t) = F_k + (F_{s\infty} - F_k)(1 - e^{-\gamma t^n})$$

The parameters to vary are  $\gamma$  and  $n$ . These are dependent on the material of the contact surfaces and the lubricants. For conformable contacts,  $\gamma$  was determined to be in the range from 0.04 to 0.64 and  $n$  from 0.36 to 0.67.

Stick-slip friction was included in a method provided by Karnopp (1985) for modeling dynamic systems with the above problem. Hess and Soom (1990) employed a friction model of the form given below for explaining their experimental results.

$$F = \left[ F_k - F_v|v| + (F_s - F_k) \frac{I}{I + (v(t - \tau_L) / v_s)^2} \right] \text{sgn}(v)$$

In this model, the second term represents the viscous friction and the last term corresponds to the Stribeck effect observed in the friction. The more important property of this model is to include the hysteresis effect as reported in the experimental results. The lag is assumed to be a pure time delay,  $\tau_L$ , which depends on the lubricant viscosity and the normal force.

Derjaguin et al. (Armstrong-Hélouvy, 1991) proposed another model to explain the transient behavior. Their model is represented in the following way

$$F_s(t) = F_k + (F_{s\infty} - F_k) \frac{t}{t + \gamma}$$

where  $F_{s\infty}$  is the steady state static friction,  $F_k$  is the kinetic friction and  $\gamma$  determines the rise time of the static friction and which varies among different systems.

Another model which approximately captures the true nature of sticking was proposed by Haessig and Friedland (1991). This was called the “bristle model”.

In the widely referenced survey paper, Armstrong-Hélouvry (1994) chose a seven-parameter model for study. This model incorporates Coulomb, viscous and Stribeck friction with frictional lag and rising static friction. This model also predicts all the phenomenon observed in the friction experiments so far.

Polycarpou and Soom (1992) have reported dynamic measurements of friction in lubricated metal contacts made with a remarkably sensitive apparatus. All the features of the seven-parameter model with the exceptions of the viscous and rising static friction effect, have been verified by the experimental data of Polycarpou and Soom (1992).

Next we will have an overview of the friction models available in the state space form. The models represented in the literature are of the form

$$\begin{aligned} F &= \lambda(f, v) \\ \dot{f} &= \phi(f, v) \end{aligned}$$

where  $f$  is called the normalized friction force. The functions  $\lambda(\cdot)$  and  $\phi(\cdot)$  characterize a specific friction model.

Among the earliest state space models is the one proposed by Dahl (1976). His study involved understanding friction in finite small rotation of ball bearings with a spring force. The state space model proposed by him is given as

$$\begin{aligned}\dot{f} &= cv|I - f \operatorname{sgn}(v)|^i \operatorname{sgn}[I - f \operatorname{sgn}(v)] \\ F &= af\end{aligned}$$

where  $i$  is a measure of the slope of the friction curve,  $a$  determines the magnitude of the force and  $c$  determines the width of the hysteresis band.

Ruina (1980) explained the friction present between the earth's crystal plates when they move relative to each other. His model is represented by means of the following equations

$$\begin{aligned}\dot{f} &= -\frac{v}{L}\left[f + b \ln \frac{v}{v_o}\right] \\ F &= F_o + a \ln \frac{v}{v_o} + f\end{aligned}$$

In this model,  $L$  is the characteristic parameter.

Walrath (1984) proposed an empirical friction model to explain the friction present in the bearings. His model is given as

$$\tau \dot{F} = -F + T \operatorname{sgn}(v)$$

where  $T$  is the friction torque,  $v$  is the relative gimball velocity and  $\tau$  is an adjustable model parameter. He then went on to design an adaptive controller based on this model for an airborne optical pointing and tracking telescope.

Haessig and Friedland (1991) proposed a "reset integrator" model for friction, which is easier to implement and use than their previous bristle model. The reset integrator model shows results similar to those obtained by Karnopp (1985). The reset integrator model is given as



$$\dot{f} = c[v - \phi^{-1}(f)]$$

$$F = cf$$

where  $c$  is a parameter that determines the width of the hysteresis and  $\phi^{-1}(v)$  is the inverse function of  $\phi(v)$ . Function  $\phi(v)$  is an odd function that varies between  $\pm 1$ .

Among the recently proposed models, one of the significant ones is the Canudas model as proposed by Canudas de Wit et al. (1993). This captures most of the friction behavior observed experimentally. The model proposed by them can be represented as

$$\dot{f} = v - \frac{|v|}{g(v)} f$$

$$F = \sigma_0 f + \sigma_1 \dot{f} + \sigma_2 v$$

where  $g(\cdot)$  is a function that is defined by the material and lubricant properties and conditions. The other parameters are the stiffness, damping and viscous friction parameters represented by  $\sigma_0$ ,  $\sigma_1$  and  $\sigma_2$  respectively.

Harnoy and Friedland (1993) proposed a model developed for dynamic friction in lubricated line contacts which entails a 4th order differential equation. They use an experimental apparatus where friction can be isolated and measured for lubricated short journal bearings. The model was verified by experimental results obtained by measuring friction using the apparatus. The same model can easily be extended to other contact geometries. Later, another modified and improved dynamic friction model was proposed by Harnoy et al. (1994) for friction forces in lubricated sleeve bearings.

Other than the models discussed above, various alternate friction models also have been proposed over the years. The main goal of these models being minimization of the algorithmic complexity and simulation time while still providing reasonably

accurate results. Many researchers have tried to work with the simplest model viz. Stiction + Coulomb friction model, but replacing the apparent discontinuity at zero velocity by a curve of high, but finite slope. This makes the algorithm simpler at the cost of a reduction in the required minimum step size. Also, these models do not provide for stiction (when mechanism stops for a finite time due to a higher static friction). Several other methods also have been proposed but reviewing them all is obviously out of the scope of this thesis.

Hence as discussed in this chapter, friction models have evolved from the very simple classical model to the present day sophisticated dynamic friction models. The choice of a model for a particular application presents a compromise between accuracy obtained in the friction estimate and the simplicity of the algorithm. However, even simple models usually provide excellent accuracy and may suffice for some applications where the cost for a complex model may not be justified. But extremely high verisimilitude may require a dynamic model of friction.

## CHAPTER 3

### METHODS OF FRICTION COMPENSATION

Control system designers have attempted to cope with the undesirable effects of friction in various ways. Compensation of friction is critical for applications with very low velocities. Friction also creates problem when the direction of motion reverses frequently. Even when tracking at high velocities is involved, the performance can improve significantly if one of the friction compensation techniques is used.

#### 3.1 Classification of Compensation Techniques

The compensation techniques can be broadly classified into three categories, which are:

- Problem avoidance
- Non-model based compensation
- Model based compensation

Detailed literature survey for these categories was presented by Armstrong-Hélouvry et al. (1994).

Problem avoidance is not exactly a direct compensation technique but involves indirect compensation for a part of friction by modifying the physical quantities involved. The remaining two techniques deal with friction force by applying an equal force through the actuator in the opposite direction. This is aimed towards canceling out the friction force and making the system behave like a frictionless system, whereby any standard control technique can be utilized for a desired performance.

### 3.2 Problem Avoidance

Instead of solving a problem, it is often the first choice of an engineer to avoid the problem. This is quite true even with the problem of friction. It has been reported that the stick-slip, which is the main problem with systems involving friction, can be significantly reduced or eliminated completely, just by decreasing the mass, increasing the damping or increasing the stiffness of the mechanical system (Rabinowicz, 1959; Singh, 1960; Kato et al., 1974). The changes in the above quantities require suitable choice of lubricants, bearings or a surface coating of the contact surfaces by a different material. Even an appropriate choice of actuators and sensors can bring about a change in system damping, inertia and stiffness.

A vast literature discusses using these modifications in the design of a system for avoiding the deleterious effects of friction force. We will try to briefly discuss the various techniques used currently.

Lubricant selection is mainly done for the purpose of reducing or eliminating the negative slope of the friction-velocity characteristic at very low velocities. The negative slope is the main destabilizing factor but if it can be reduced, it becomes easier to apply active control for stabilization. Various lubricant categories exist which can achieve the above mentioned purpose. Choice of bearings is also governed by similar goals. Engineers often use oil or air hydrostatic bearings to avoid the non-linearity of low-velocity friction. Even active magnetic bearings are being used for high velocity applications.

The next factor to be considered is the problems caused by the presence of friction in a mechanical system with transmission elements. The latter reduce the stiffness of the system. Ideally the transmission should be designed to be stiff or should be avoided altogether. However, elimination of the transmission components may require high-torque motors to drive the system and hence may not be economical. Friction, in presence of transmission, gives rise to nonlinear resonance phenomenon and leads to the stick-slip problems. The stick-slip problem is present only in systems with 2 or more degrees of freedom which arise due to resilient transmission. Inertia reduction is another way to stabilize a system which shows stick-slip instability. However, this is not always possible in actual systems but should be attempted whenever possible.

While the above measures do not always eliminate the problem completely, they definitely make the control problem easier. Design for control can bring significant improvements in performance and further improvements can be achieved by applying active control techniques.

### **3.3 Non-model Based Friction Compensation**

Engineers have been applying several indirect techniques to cancel out the effects of friction force. In the non-model based compensation, friction described by a mathematical model, is not estimated; instead, it is canceled out by applying special control techniques.

As mentioned in the previous section, increasing the stiffness of the system reduces or even eliminates the stick-slip problem. This approach of increasing the

stiffness of the system has always been a popular method among the engineers. In the foregoing section, modifying the physical properties was discussed. The control engineer tries to achieve this by means of the controller parameters. But most of the initial literature with this approach assumed non-memory models for friction which works well for system where the frictional memory is negligible.

Armstrong-Hélouvy (1992) studied a model which included the Stribeck friction in addition to the viscous and static friction. He included the friction memory by assuming a simple time lag in the Stribeck component. After carrying out the analysis by a perturbation method, he concluded that a system with single degree of freedom having a sliding mass,  $M$ , will not experience stick-slip for moderate amounts of friction if the system stiffness meets or exceeds a critical value given by

$$K_{cr} = M \frac{\pi^2}{\tau_l^2}.$$

Note that as the time lag approaches zero i.e. the friction memory becomes negligible, the critical stiffness approaches infinity. This analysis was tested and verified by experimental data from the base joint of a PUMA robot. Recently, Dupont (1993, 1993a, 1994) used a PD controller for friction compensation and derived conditions to avoid stick-slip instability.

Integral control is a very popular in position and velocity control applications to minimize steady-state errors. However, integral action often sends systems into limit cycles. One of the popular techniques to overcome this shortcoming in integral control is addition of a deadband before the integrator. This obviously adds a steady-state error in the system. Shen and Wang (1964) showed that the required width of the deadband

increases if higher ramp rates are given as reference. To improve the system performance for all ramp-rates, they proposed an adaptive control of the deadband width. Another problem appears in an integral controller when the velocity reversals are involved. The accumulation of the integral from earlier motion can delay breakaway in the other direction. This is usually solved by resetting the integrator at velocity reversals. But this then provides another delay before the integrator builds up for breaking away from stiction. This can lead to undesirable tracking errors if frequent velocity reversals are required. Hansson et al. (1993) applied a fuzzy rule system to overcome these problems.

A very popular method in present applications is addition of a dither to the input signal. Dither is a high-frequency component added to a normally required control signal. It has been shown that dither can actually stabilize systems (Bogoliubov and Mitropolsky, 1961) and improve performance by modifying the non-linearities involved. The main aim of a control engineer in using a dither is to avoid the discontinuity of friction at low velocities. There are two kinds of dither used by the engineers, viz. tangential dither and normal dither. These have been dealt in detail by Armstrong-Hélouvry (1994). However, dither is not always recommended for systems where high frequencies are a problem. Dither introduces very high frequency vibrations in the systems which sometimes may not be tolerated by the physical system. Hence, they can be used only where the system is reasonably immune to high frequency vibrations. Dither also causes noisy behavior which is not acceptable when high ultimate accuracies are desired.

A variant of dither can be considered to be the impulsive control. Researchers have proposed controllers which achieve precise motion in presence of friction by application of impulses (Yang and Tomizuka, 1988; Suzuki and Tomizuka, 1991; Armstrong, 1988; Armstrong-Hélouvy, 1991; Deweerth et al., 1991; Hojjat and Higuchi, 1991). Dither is usually a zero mean signal which doesn't cause any relative motion, whereas impulse is required to cause the desired motion. This requires calibration of the impulse amplitudes. The impulse of a calculated amplitude is applied when the system is at rest to cause a very precisely calculated displacement. Hojjat and Higuchi (1991) achieved accuracy upto 10 nm and speculate that 1 nm impulse motions may be possible.

Wu and Paul (1980) proposed a new technique called the "joint torque control". This technique uses sensors to measure torques and feedback to the actuator. They demonstrated that disturbances due to undesirable actuator characteristics or transmission behavior, which include more than only friction, can be significantly reduced by such a kind of feedback.

Many other non-model based methods have been proposed in the literature. Friedland et al. (1976) proposed a design in which friction was represented in form of random walk and the feedback was designed by linear optimal control theory which leads to an integral control. Kubo et al. (1986) observed friction does not necessarily always destabilize the system and proposed a new kinetic friction feedback design to avoid over-compensation. Describing function analysis has been applied (Townsend and Salisbury, 1987) to study and compensate for friction by means of an integral controller. These



alternative methods also have proved to be effective in certain specific applications and should definitely be considered in applications similar to the ones studied by the above researchers.

### 3.4 Model Based Friction Compensation

With model-based compensation, the friction is estimated using a mathematical model and canceled by applying an equal amount of force in the opposite direction. However, an important fact to be noted here is that this is possible only in systems where friction appears exactly at the location where the control input is applied. Most of the friction models which are utilized by engineers have one or more unknown parameters which characterize a particular system. This gives possibility of two kinds of model based friction compensation, viz. fixed compensation and adaptive compensation.

In fixed compensation, one usually carries out the calculations for the unknown parameters off-line after performing some specific tests and fitting the parameters by means of any of the prevalent methods. However, in most cases, friction parameters vary over time and depend on specific conditions. This leads to a need for frequent tuning of the calculated parameters. The more efficient way is to use the adaptive friction compensation.

Among the earliest adaptive systems was the Model Reference Adaptive Control (MRAC) system developed by Gilbert and Winston (1974) for telescope tracking problem. They reported a reduction of a factor of six in the RMS error by using the

MRAC system. Since then numerous algorithms have been proposed for on-line estimation of the unknown parameters.

A typical approach is to compensate for the Coulomb friction. In this thesis, we are considering the adaptive friction compensation technique proposed by Friedland and Park (1992). Canudas de Wit et al. (1987) showed that the need for high servo gains is eliminated by Coulomb friction compensation. Canudas de Wit et al. (1987, 1991) developed an algorithm to adaptively compensate for Coulomb friction. Canudas de Wit and Seront (1990) also then designed a feedback law to remove the instability problems in case of inexact friction compensation.

Brandenburg and Schäfer (1988, 1989) and Schäfer and Brandenburg (1990) proposed a “disturbance observer” which employed a feedforward Coulomb friction compensation. They concentrated on elimination of limit cycles rather than the accuracy of the system. Friedland and Park (1992) developed an observer algorithm for adaptively compensate for friction. They designed the observer for the Coulomb friction model. Later this algorithm was extended by Friedland and Mentzelopoulou (1992) for cases involving unmeasurable velocity. They coupled a velocity observer to the Coulomb friction observer. Recently, Tafazoli et al. (1995) proposed a modification to this velocity observer for better estimates.

Maqueira et al. (1993) proposed an adaptive Coulomb friction compensation method for applying to line-of-sight pointing and stabilization problem. The parameters in a simple reference friction model are estimated on-line and used for canceling the

friction effects. The parameters estimated are the Coulomb friction level and a spatial time constant.. Cancellation of friction is carried out by using relative rate feedforward.

While the simplest Coulomb friction model compensation techniques have demonstrated good performance, researchers have shown some improvements by using richer friction models. Brandenburg and Schäfer (1991) and Johnson and Lorenz (1991) used a Karnopp friction model to perform static friction modeling and compensation. Experimental results show an improvement over pure Coulomb friction compensation.

Craig (1986) and Kuc et al. (1991) proposed another technique of learning control (also called repetitive control). Learning control involves using a look-up table, which is created off-line by experimental measurements, to add a feedforward control for a particular trajectory. The table is 'learned' during the precise motions. This method is very effective in applications which involve highly repetitive tasks. A correction table thus developed will compensate for all non-linearities including friction.

Armstrong-Hélouvry et al. (1994) included an extensive survey of the current techniques actually used by the engineers in industry. According to him, the most common and successful approach to solving the friction problem is that of system hardware modification. Control engineers in industry often considered machine design and proper lubricant selection as the first and perhaps the only necessary step in approaching a friction problem. In some applications, engineers attempt to increase the amount of Coulomb friction present in the system to overcome the dominance of stiction at low velocities. Other prevalent practices were found to be high servo gains (stiff position and velocity control), dither and table lookup compensation. Some other

methods like learning control, joint torque control and variable structure were also reported.

In this chapter, the techniques employed for friction compensation were briefly reviewed. In this thesis, an effective model-based compensation for friction is implemented. The Coulomb friction observer as proposed by Friedland and Park (1992) and later extended by Friedland and Mentzelopoulou (1992) has been utilized to estimate friction present in a special experimental apparatus. The friction estimate is the used to cancel out the friction. This thesis also verifies the modification proposed by Tafazoli et al. (1995) to the velocity observer part of the above mentioned Coulomb friction observer. The special experimental apparatus also allows the friction present in the system to be measured. The observer results are verified by comparing to the actual friction force measurements.

## CHAPTER 4

### COULOMB FRICTION ESTIMATION AND COMPENSATION

In the present work, a Coulomb friction observer was implemented on a special experimental apparatus where friction could also be physically measured. The observer implemented is the one proposed by Friedland and Park (1992). The observer is designed such that the estimate error converges asymptotically to zero.

#### 4.1 Problem Definition

State space equations of a unit-mass frictionless ideal mechanical system are given by

$$\dot{x} = v$$

$$\dot{v} = u$$

where  $x$  is the position,  $v$  is the velocity and  $u$  is the total force acting on the system.  $u$  includes all the forces present in the system including friction. From now on, we will interchangeably use the terms force and torque as they are similar depending on whether the motion is linear or rotational.

Usually, the input force  $u$  is in the form of a control law which depends on the controller design. For example, for a position control system, the input is given by:

$$u = -k_1(x - x_o) - k_2v$$

where  $x_o$  is the desired position to be obtained. The gains  $k_1$  and  $k_2$  are usually calculated by control methods like linear optimal control (Friedland, 1986).

The system considered earlier does not always match the actual system closely, the main difference being the presence of friction which comes as a subtractive term in the second equation. The actual system with friction is given as:

$$\begin{aligned}\dot{x} &= v \\ \dot{v} &= u - F(\lambda_1, \lambda_2, \dots, v)\end{aligned}$$

In this equation a new term  $F(\lambda_1, \lambda_2, \dots, v)$  for friction has been added.  $\lambda_1$  etc. are the parameters of a particular friction model. More specifically for the Coulomb friction model considered in this thesis, there is only one parameter,  $a$ . Usually, other parameters also can be absorbed in  $a$  and it can be written as a function of velocity  $v$ . e.g. Armstrong-Hélouvy (1991) and Canudas de Wit (1990,1991) considered a model in which  $a(v)$  can be represented as:

$$a(v) = a_1 + a_2 e^{-a_3|v|} + a_4|v|$$

here  $a_1$  represents static friction,  $a_4$  represents viscous term and  $a_2$  and  $a_3$  characterize the Stribeck friction.

The problem of friction compensation involves accurate estimation of the friction force term appearing in the system equations so that it can be canceled out by adding an equal and opposite term to the otherwise required control. This should make the system behave like an ideal system with no friction. Note that it becomes very convenient to cancel out the friction in this manner because the friction appears exactly at the location where the control input is applied. Systems where friction appears at a place different from where the control is applied, are still a problem under research. This situation also gets simplified if the system has high stiffness from the control input to the place where friction appears.

## 4.2 Observer Dynamics

One extension and one modification has been made since the observer was proposed in its original form by Friedland and Park (1992). We will start with the original design and then introduce the extension and the modification.

### 4.2.1 Coulomb Friction Observer - Original Form

Friedland and Park (1992) developed this method for compensating friction which is modeled as a constant times the sign of the velocity, which basically represents the Coulomb friction model. The purpose of the observer is to estimate the constant parameter involved. The observer is designed to ensure the convergence of the error to zero if the actual friction conforms to the classical Coulomb friction model. However, as shown in earlier work (Mentzelopoulou, 1994) and also in this thesis, the observer performs remarkably well even when the actual friction differs from “ideal” Coulomb friction. The observer displays ability to track a varying friction coefficient.

The structure of the observer is proposed to be

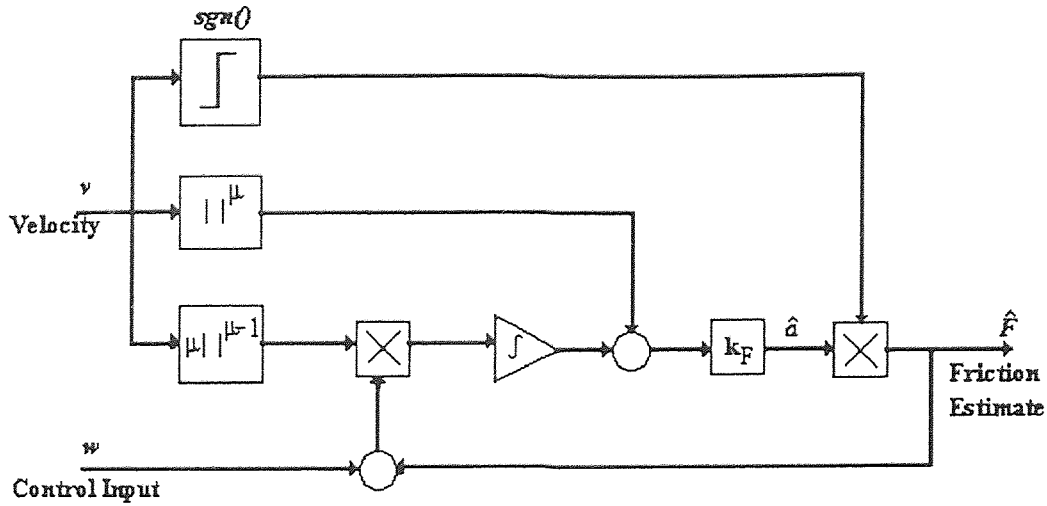
$$\hat{a} = z - k |v|^\mu$$

$$\hat{F} = \hat{a} \operatorname{sgn}(v)$$

where the gain  $k > 0$  and the exponent  $\mu > 0$  are parameters and the variable  $z$  is given by

$$\dot{z} = k \mu |v|^{\mu-1} [u - \hat{F}] \operatorname{sgn}(v)$$

A block diagram representation for the observer is shown in Figure 4.1.



**Figure 4.1** Coulomb Friction Observer - as proposed in its original form. This form assumes availability of measured velocity.

For the selection of the two parameters present in the observer, consider the error analysis as shown by Friedland and Park (1992). Define  $e$  to be the error of estimate,

$$e = a - \hat{a}$$

Taking the derivative on both sides of the equation, we get

$$\begin{aligned}
 \dot{e} &= -\dot{\hat{a}} \\
 &= -\dot{z} + k\mu|v|^{\mu-1}\dot{v}\operatorname{sgn}(v) \\
 &= k\mu|v|^{\mu-1}\operatorname{sgn}(v)[\dot{v} - u + \hat{F}] \\
 &= -k\mu|v|^{\mu-1}\operatorname{sgn}(v)[F - \hat{F}] \\
 &= -k\mu|v|^{\mu-1}\operatorname{sgn}(v)[(a - \hat{a})\operatorname{sgn}(v)] \\
 &= -k\mu|v|^{\mu-1}e
 \end{aligned}$$

which would converge asymptotically to zero if  $k > 0$ ,  $\mu > 0$  and  $v$  is bounded away from zero.



The main reason behind estimating the friction force is to cancel it out. Hence, we would add a feedback term to our control input. For position control, we can represent it as

$$u = -k_1(x - x_o) - k_2v + \hat{F}$$

The simulation studies for the “ideal” system with the above observer designs are given in Friedland and Park (1992) and Mentzelopoulou (1994).

Mentzelopoulou (1994) also derived the error convergence conditions for the case when the parameter  $\alpha$  is not a constant and is a function of velocity (“extended” Coulomb friction). The additional condition, other than that the observer gain and order be positive, was shown to be that there be a bound on  $\frac{\partial \alpha}{\partial v} \dot{v}$ . This condition was shown to be always valid if the acceleration in the system was bounded. It was suggested that for a square wave reference signal case, when the velocity contains delta functions, the acceleration theoretically becomes infinite. In practical cases, however, the acceleration will have a finite value. Moreover, the duration of the interval of large acceleration is very small, which should ultimately allow the observer to converge.

The above described observer was shown to perform exactly as predicted for cases when the friction follows the ideal classical Coulomb model. However, more interestingly, the observer demonstrated an ability to ‘track’ the friction coefficient even if it is not a constant as assumed in designing the observer (Friedland and Park, 1992; Friedland and Mentzelopoulou, 1992).

### 4.2.2 Extension of the Coulomb Friction Observer

The observer as given in its original form assumes that the state variables, namely position and velocity, are measurable. However, in numerous applications, the velocity may not be available for measurements. Friedland and Mentzelopoulou (1992) considered the problem of estimation and compensation of friction that may be present in systems where velocity is not available for direct measurement. They used the theory of reduced-order observers to design a two-stage nonlinear observer which would simultaneously estimate the velocity and the friction. This observer in fact consisted of two coupled observers: one to estimate the velocity and other using this estimate of velocity to estimate the friction coefficient. The conditions for local stability were derived for selecting the observer gains.

The observer design is given as

- Velocity Observer:

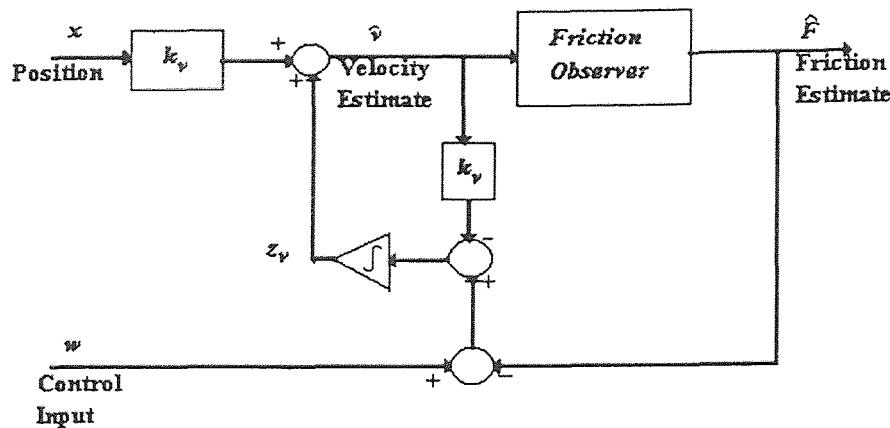
$$\begin{aligned}\hat{v} &= z_v + k_v x \quad \text{where,} \\ \dot{z}_v &= -k_v \hat{v} + u - \hat{F}\end{aligned}$$

- Coulomb Friction Observer:

$$\begin{aligned}\hat{F} &= \hat{a} \operatorname{sgn}(v) \\ \hat{a} &= z_F - k_F |\hat{v}|^\mu \quad \text{where,} \\ \dot{z}_F &= k_F \mu |v|^{\mu-1} (u - \hat{F}) \operatorname{sgn}(\hat{v})\end{aligned}$$

The block diagram for the above observer is given in figure 4.2.

Note that usually the control term is made to be of the form  $u = w + \hat{F}$ , where  $w$  is the normally designed control law signal. Hence, in the above equations, we can replace  $u - \hat{F}$  by  $w$ .



**Figure 4.2** Coulomb Friction observer - Extended form. This form uses a coupled velocity observer and does not need measurable velocity.

The error analysis for the above observer design is available in Friedland and Mentzelopoulou (1992). The conditions they derived for convergence of error to zero are that both the observer gains, namely  $k_v$  and  $k_F$  be positive for a system which has the ideal Coulomb friction. An additional condition for systems with “extended” Coulomb friction (Coulomb+viscous+Stribeck friction) is shown to be that  $\frac{\partial a}{\partial v} \dot{v}$  be bounded. Mentzelopoulou (1994) also extended to apply this observer to systems having multiple degrees of freedom.

Simulation results (Friedland and Mentzelopoulou, 1992) and experimental results (Mentzelopoulou, 1994) have shown the observer to perform as predicted. As mentioned earlier the system demonstrates capability to track a non-constant friction which is a function of velocity. However, the only possible drawback is that the observer does not seem to capture the hysteresis effect well. One possible explanation as given by

Tafazoli et al. (1995) is that the observer convergence rate depends upon the magnitude of the velocity and since the maximum change in friction occurs at low velocities, the observer can not converge fast enough to capture that effect. Also they proposed that at zero velocity the friction is actually equal to the force applied to the system and not a constant. In fact, friction acts more like a constraining force. They proposed a modification to the velocity observer part in the above design which is given in the next section.

#### 4.2.3 Modification to the Velocity Observer

Tafazoli et al. (1995) attempted application of the above observer to an automated machine for industrial fish head cutting. Their experimental results indicated that the observer in the original form did not give good results and hence proposed a modification to the velocity observer. Their repeated experiments with the modified design showed satisfactory estimation of velocity and friction.

The problems they encountered while implementing the original design are

- Some backlash behavior due to the deadband non-linearity arising out of friction.
- Velocity estimation differed significantly from the FIR filtered position data and also showed a lot of distortion.
- Estimated friction was less than what was obtained experimentally.

They argued that the friction estimate is not correct in the vicinity of zero velocity. The friction force when  $v = 0$  is equal to the force acting on the system and not

a constant as assumed by the model. They proposed that at zero velocity friction should be considered as a constraint. To solve this problem a modification was proposed by Tafazoli et al. (1995). The modified velocity observer is given by

$$\begin{aligned}\hat{v} &= z_v + k_v x \\ \dot{z}_v &= -k_v \hat{v}\end{aligned}$$

This modified observer is effectively a low-pass differentiator, i.e., it behaves as a differentiator for low velocities. The transfer function for this low-pass differentiator can be given as

$$\frac{\hat{v}}{x} = \frac{k_v s}{s + k_v}$$

The experimental results using this modified observer were very promising. The velocity estimate agreed well with the FIR filtered position data. Tafazoli et al. (1995) claim that the modified observer performs well due to its decoupling from the friction observer.

The experimental results also showed some hysteresis in the friction-velocity characteristics. However, they could not capture the Stribeck friction at low velocities and argued that the low velocities are passed very quickly, allowing very little time for the observer to converge to the true values of friction.

As seen so far, the Coulomb Friction observer proposed by Friedland and Park (1992) has undergone one extension (Friedland and Mentzelopoulou, 1994) and one modification (Tafazoli et al., 1995). The amount of interest shown in this observer reasserts the good applicability of this observer to practical applications. The observer is

very easy to implement and still gives remarkable improvement in performance over systems without any type of friction compensation.

### **4.3 Study Performed in this Thesis**

In this thesis, study has been undertaken to confirm the differences obtained by using the observer in its original form and with the modification proposed by Tafazoli et al. (1995). Position as well as velocity control has been implemented. Most of the researchers utilizing this observer have implemented only position control laws. In this work, a simple proportional velocity controller has also been implemented and very low velocity control has been attempted. This thesis also attempts to obtain a well-defined estimated friction-velocity characteristic by obtaining the desired velocity profile as against the characteristic obtained while only position was controlled and the velocity obtained did not follow any well defined profile. Mainly a sinusoidal variation in velocity is obtained so that the estimated friction could be compared to theoretical results which are usually shown for sinusoidal velocities.

The above study has been done by implementing the algorithms on an apparatus which was originally designed for measuring friction (Harnoy et al., 1994) and developing the dynamic friction model for lubricated contacts (Harnoy and Friedland, 1991). Hence, the experimental estimation results permit comparison with the physical friction measurements obtained earlier.

## CHAPTER 5

### IMPLEMENTATION OF THE COULOMB FRICTION OBSERVER

In this chapter, the experimental results are presented for the friction estimation and compensation technique discussed in the previous chapter. The experiments are done to verify the improvement in performance with the “Tafazoli modification” (Tafazoli et al., 1995) to the Coulomb friction observer as originally proposed by Friedland and Park (1992) and extended by Friedland and Mentzelopoulou (1994). Experiments are also performed to verify the improved accuracy in both position and velocity control systems.

#### 5.1 Experimental Apparatus

The experimental apparatus used is shown in Figure 5.1. This apparatus was originally designed for measuring dynamic friction in lubricated journal bearings (Harnoy et al., 1994) to verify the theoretical model developed by Harnoy and Friedland (1993). In prior experiments, friction was physically measured and currently work is being done towards fitting the data to the theoretical model by identifying suitable parameters. The apparatus is specifically designed to measure dynamic friction without the errors caused by inertial forces, as in some of the available test machines. The cross section of the mechanical apparatus is shown in Figure 5.2.

The dominant friction-creating elements in the apparatus are the four sleeve bearings. The normal load on these bearings can be varied as desired, thus giving desired

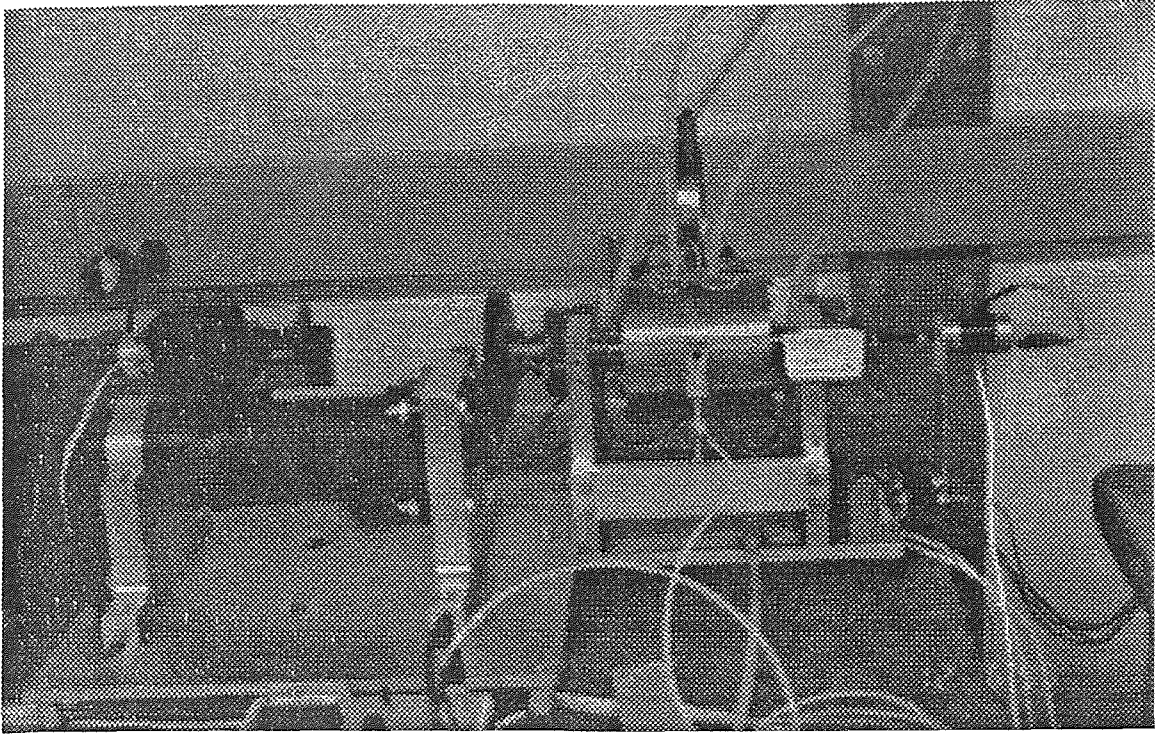


Figure 5.1 Photograph of the experimental apparatus.

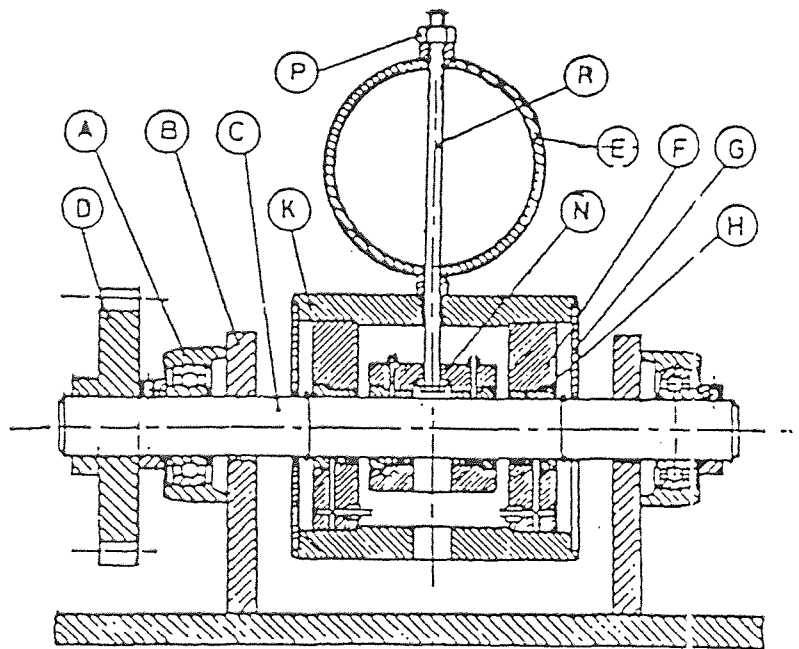


Figure 5.2 Cross-section of the friction measuring apparatus.



levels of friction. Detailed description and the friction measurements can be found in Harnoy et al. (1994).

The apparatus is driven by a servo motor which is controlled by an IBM-compatible personal computer (486-33). The real-time interfacing, A/D conversions, D/A conversions and timing is being carried out by means of an IBM Data Acquisition and Control Adapter (DACA) board mounted on the computer motherboard.

The servo motor is equipped with an incremental encoder which provides 4000 pulses per revolution, thus giving a very high resolution. The pulses are interfaced to the DACA board through a Hewlett-Packard HCTL2016 counter driven by a MX05HS 8 MHz clock generator. The counter effectively provides the measured position from the shaft. Notice that the motor shaft and the apparatus shaft are connected by a timing belt and could produce some backlash and stiffness problems. Experimentally, however, it was verified that the system showed no significant backlash even with such high resolution measurements and also was very stiff. The control signal was generated through the D/A converter on the DACA board and was amplified by an external power amplifier module (Techron 7520).

The algorithms were implemented using the C programming language in MS-DOS environment. The LabWindows User-Interface Library was utilized for creating a Graphical User Interface (GUI). The source code listings are given in Appendix. Appendix also contains a screen shot of the GUI and instructions for use. The sampling rate was fixed at 500 Hz which is much above the required Nyquist rate for any

frequency in the system. The integrations were performed using the first-order Euler algorithm.

System was also modeled in the SIMULINK modeling environment for simulation and design verification purposes.

## 5.2 System Identification and Control Design

First stage of the experiment was to characterize the physical system. The system is basically a load driven by a motor. The characteristic equations for such a system are generally given by

$$Ri + L \frac{di}{dt} = u - k_{\omega}\omega$$

$$J\dot{\omega} = K_t i$$

where,  $k_{\omega}$  and  $k_t$  are the back-emf and torque constants respectively.  $u$  is the voltage applied to the motor,  $I$  is the armature current,  $\omega$  is the angular velocity (henceforth will be replaced with  $v$  to be consistent with earlier chapters),  $J$  is the net equivalent moment of inertia,  $R$  is the armature resistance and  $L$  is the armature inductance.

To characterize the system, a step response for the system was obtained. First it was verified that the electrical time constant (due to  $R$  and  $L$ ) was negligible to the time constant observed in the step response and hence could be neglected when compared to the mechanical time constant. The system equations, after some simple algebraic operations, can be written as follows

$$\dot{x} = v$$

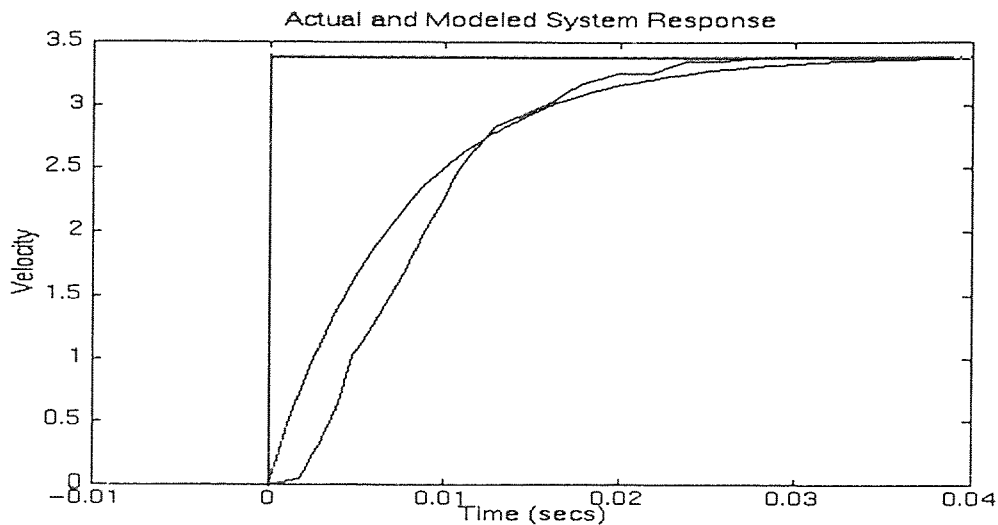
$$\dot{v} = -\frac{k_t K v}{RJ} v + \frac{k_t}{R} u$$

where the armature inductance has been neglected and all references to  $\omega$  have been replaced by  $v$ . Now the system is in the standard state space form, where the states are  $x$  and  $v$ .

The step response data is used to determine the two unknown coefficients in the equations. MATLAB functions are used to fit the data to this simple first-order system model. The system is finally characterized to be of the form

$$\begin{aligned}\dot{x} &= v \\ \dot{v} &= -135v + 457u\end{aligned}$$

The actual step response and the modeled step response are shown in following graph.



**Figure 5.3** Actual and modeled system step response.

The system has been assumed to be frictionless while characterizing. Some of the viscous friction also gets absorbed in the first coefficient (since it is also proportional to velocity, as the back emf term). The step response test was made with no load on the bearings, hence this difference should become negligible when loads are applied later to get higher levels of friction.

Next step is to design the control law for this frictionless system. Both position and velocity control systems were designed.

For the position control we use a control law of the form

$$u = -k_1(x - x_o) - k_2v$$

where  $x_o$  is the reference position. The gains  $k_1$  and  $k_2$  are designed by pole placement method to obtain the desired damping and natural frequency. The gains were calculated to be  $k_1 = 0.43764$  and  $k_2 = -0.25164$ .

For velocity control we use a simple proportional controller with a feedforward term for the reference velocity, as used also by Carli et al. (1994). Proportional controller is simple to design by finding the range of gains for which the system will remain stable. So the control law is of the form

$$u = -g_1(v - v_o) + Cv_o$$

where  $v_o$  is the reference velocity.  $C$  can be easily calculated from the system dynamics and is found to be 0.295;  $g_1$  is chosen to be 1.0.

### 5.3 Observer Algorithms

For the experimental study, first the Coulomb friction observer in original form was considered. The observer equations as required in the experimental system are given as follows:

- Velocity Estimation

$$\hat{v} = k_v x + z_v$$

$$\dot{z}_v = -k_v v + 457u - 135v$$

- Friction Estimation

$$\hat{F} = \hat{a} \operatorname{sgn}(\hat{v})$$

$$\hat{a} = z_F + k_F |\hat{v}|$$

$$\dot{z}_F = -k_F (457u - 135v) \operatorname{sgn}(\hat{v})$$

The above equations are based on the assumption that the friction has been compensated for by an equal term added to  $u$  as explained in the next section. In the above equations, the observer gains are to be determined. For  $k_v$  a simple pole placement method from reduced order observer theory is employed and is found to be 15.0. For  $k_F$  we scale down one of the values already tested in earlier works and tune it experimentally to be 0.01. The order ( $\mu$ ) of the Coulomb friction observer is taken to be 1. Effects of variations in the values of  $k_F$  and  $\mu$  have already been studied and is not the purpose of this study and hence these parameters will be kept fixed for all the experiments.

For experimental purposes, the actuator saturation had to be considered, however, simulation with a saturation block did not give any significant differences in performance. However, saturation of the control signal had to be done in order to implement the observer which is reflected in the source code listing (Appendix).

Next the ‘‘Tafazoli modification’’ to the velocity observer was considered. The velocity observer after the modification is given as

$$\hat{v} = k_v x + z_v$$

$$\dot{z}_v = -k_v v$$

the friction observer remains unaltered. The observer gains also remain unchanged in both the forms of observer.

### 5.4 Control with Friction Compensation

The control law is now modified to compensate for the friction that is estimated by the observers given above. This is achieved by adding a compensation term to the control law designed earlier. The input voltage is made to be

$$\text{Input Voltage} = u + \hat{F}$$

where  $\hat{F}$  is the estimated value of the friction force (scaled to input voltage) and  $u$  is the control law designed for a frictionless system. However, note that the system is not a unit-mass system and a constant term multiplies the input term in the system dynamics (system gain=457). Hence to compensate for friction, the estimated friction  $\hat{F}$  should be appropriately divided by the system gain to be added to  $u$ . Instead, the scaled friction itself is estimated directly and later scaled down again for plotting by using the system parameters.

### 5.5 Experimental Results

Two control experiments are performed, namely position control and velocity control. The position control experiment is similar to what has been reported in the literature so far. The main purpose is to demonstrate an improvement in the performance in terms of accuracy for position tracking applications. In the next experiment, velocity control is implemented. It is shown that control for very low velocities is possible using the simple Coulomb friction observer. With velocity control we also implement the ‘‘Tafazoli

modification” in the observer and show superior performance and better friction estimate.

### 5.5.1 Position Control Experiments

In the first experiment, we implement the position controller as designed in earlier section. The control law without friction compensation is given by

$$u = -k_1(x - x_o) - k_2v$$

where  $k_1$  and  $k_2$  were designed to be 0.43764 and -0.25164 respectively. Various forms of reference signals were internally generated in the software. The observer implemented was the Coulomb friction observer without velocity measurements in its original form. The friction was compensated by added the estimated value to  $u$ . Hence, the input voltage applied to the motor is given by  $u + \hat{F}$ . The experimental results are given in Figure 5.4.

Results clearly show a significant improvement in the accuracy and performance of the system with friction compensation technique. The steady state errors are significantly reduced. Position control for three internally generated reference waveforms was tested. Figure 5.4, 5.5 and 5.6 show the results for square, triangular and sinusoidal reference signals respectively. The observer performed well for all the waveforms. For square reference signal, the peak and rms error without compensation were found to be 0.2846 rad and 0.2260 rad respectively. Whereas, after compensation, the peak error reduced to 0.1123 rad and the rms value of error reduced to 0.0735 rad. Below are the values for triangular and sinusoidal reference signals (all values are in rad):

⇒ Triangular reference signal

- Error without compensation : peak = 1.2861, rms = 0.8324
- Error with compensation : peak = 0.6040, rms = 0.3687

⇒ Sinusoidal reference signal

- Error without compensation: peak = 1.4066, rms = 0.8807
- Error with compensation: peak = 0.7242, rms = 0.3845

These experiments are similar to the ones already reported in the literature and were mainly performed to test and verify the control design. Next section explains the results from the velocity control experiments.

### 5.5.2 Velocity Control Experiments

In the next stages of experiment, the velocity control law as designed earlier was implemented. The velocity control law without friction compensation is given as

$$u = -g_I(v - v_o) + Cv_o$$

where the gain  $g_I$  is calculated to be 1.0 and  $C$  is calculated from system dynamics to be 0.295. The reference signal used was mainly sinusoidal. For friction compensation, estimated friction value is added to the control signal. Hence, the voltage applied to the motor is  $u + \hat{F}$ .

For velocity control, the “Tafazoli modification” to the observer was implemented and friction characteristics were obtained. The main aspect of this thesis is to implement the velocity control and obtain accurate friction-velocity characteristics that can be compared with the measured characteristics. Figures 5.7, 5.8 and 5.9 show



the experimental results for square, triangular and sinusoidal reference velocities. These show a remarkable improvement over an uncompensated system in accuracy and performance. All the velocity control experiments are performed with the Tafazoli modification to the velocity observer. The quantitative errors are summarized below (all the values are specified in units of rad/sec):

⇒ Square reference errors:

- without compensation: peak = 0.5346, rms = 0.3260
- with compensation: peak = 0.1811, rms = 0.0435

⇒ Triangular reference errors:

- without compensation: peak = 1.5170, rms = 0.7463
- with compensation: peak = 0.3415, rms = 0.0962

⇒ Sinusoidal reference errors:

- without compensation: peak = 1.7860, rms = 0.9559
- with compensation: peak = 0.8662, rms = 0.1541

Clearly, there is an improvement by at least a factor of 8 in the rms error and a factor of about 4 in the peak error.

Figures 5.10 and 5.11 compare the estimated and measured friction after scaling them to the real physical units of torque. The estimated friction is qualitatively similar to the measured friction. However, estimated friction shows a higher level of friction in the viscous part and a lower amount in the Stribeck part of the friction characteristics, especially in the bi-directional experiments. The higher estimate in the viscous part may be due to the observer estimating friction from all the sources in the system whereas the

measuring apparatus isolates the friction in the bearings. The apparatus does not measure the friction present in the servo motor but which is estimated by the observer. The lower estimate in the Stribeck part of bi-directional experiments can be attributed to the finite convergence rate of the observer. The low velocities are passed very quickly and the observer does not have sufficient time to converge to the high peaks during velocity reversals.

These results prove further the ability of the Coulomb friction observer to track non-constant friction, if the change in velocity is slow enough for the estimate to converge. This point is further proved by Figure 5.12. This shows the estimated and measured characteristics for high frequencies of velocity change. As seen in this figure, the observer does not have enough time to converge to the exact values due to higher rates of changes in velocity. This makes the estimate differ significantly from the actual values. However, the control system performs quite well even for high rates of velocity changes, but with a poorer friction estimate

### 5.5.3 Very Low Velocity Experiments

As a final test for the observer, for the first time, extremely low velocity control experiments were conducted. The results prove to be very promising for motion control applications. The fact, that these creeping velocities were obtained even with a simple proportional controller, prove the applicability of the friction compensation technique.

For the low velocities control experiments, the naive controller showed, as expected, a very poor response with large errors. However, introduction of the friction

estimation and compensation allowed very low velocity control to be obtained with very good accuracies. Figures 5.13, 5.14 and 5.15 show the system responses for various reference signal waveforms.

Quantitative errors are summarized below for the various internally generated reference signals (all errors are given in units of rad/sec):

⇒ Square reference errors:

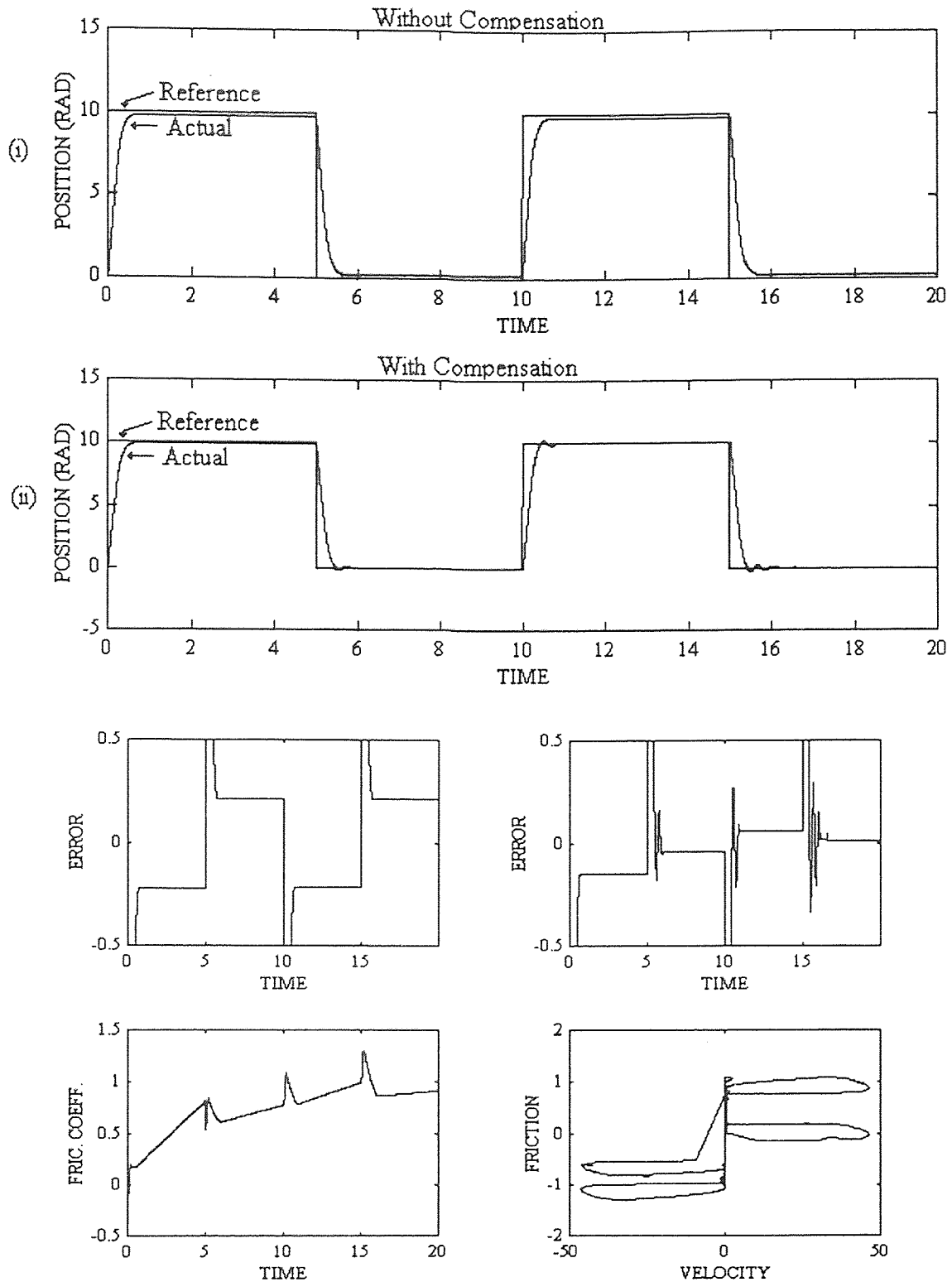
- without compensation: peak = 0.5128, rms = 0.4195
- with compensation: peak = 0.1079, rms = 0.0391

⇒ Triangular reference errors:

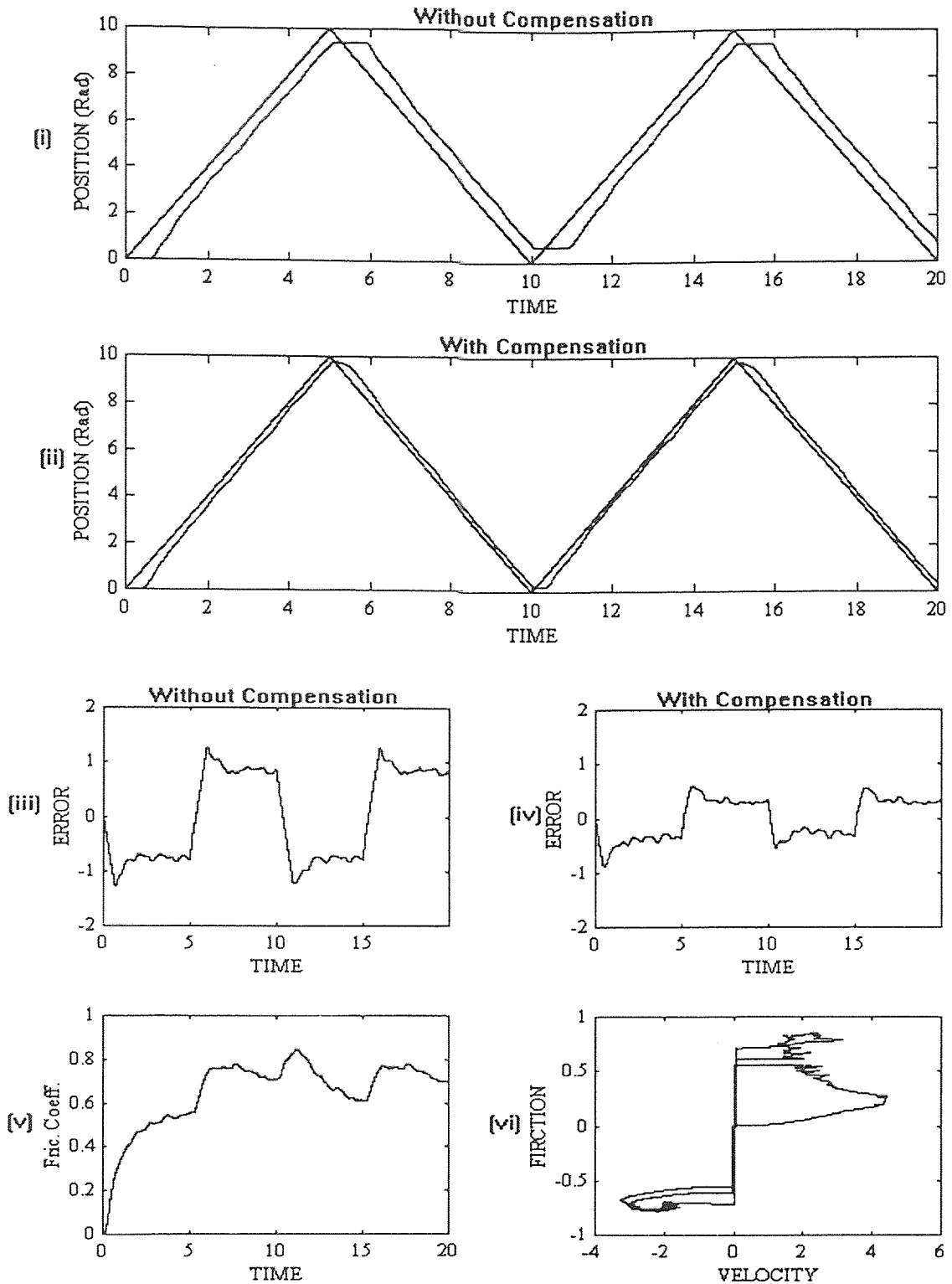
- without compensation: peak = 0.6801, rms = 0.4061
- with compensation: peak = 0.1890, rms = 0.0481

⇒ Sinusoidal reference errors:

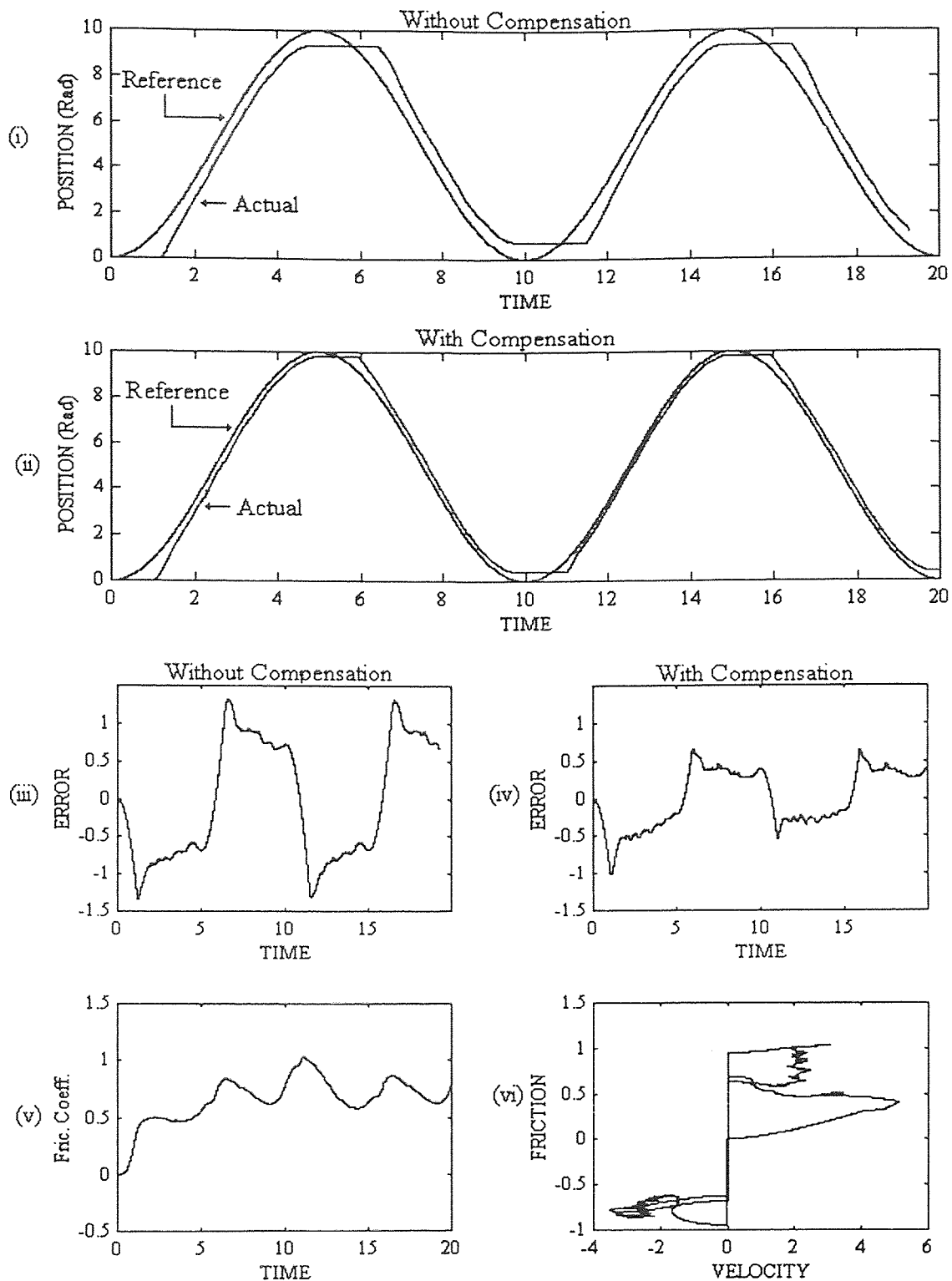
- without compensation: peak = 0.6034, rms = 0.4045
- with compensation: peak = 0.1883, rms = 0.0461



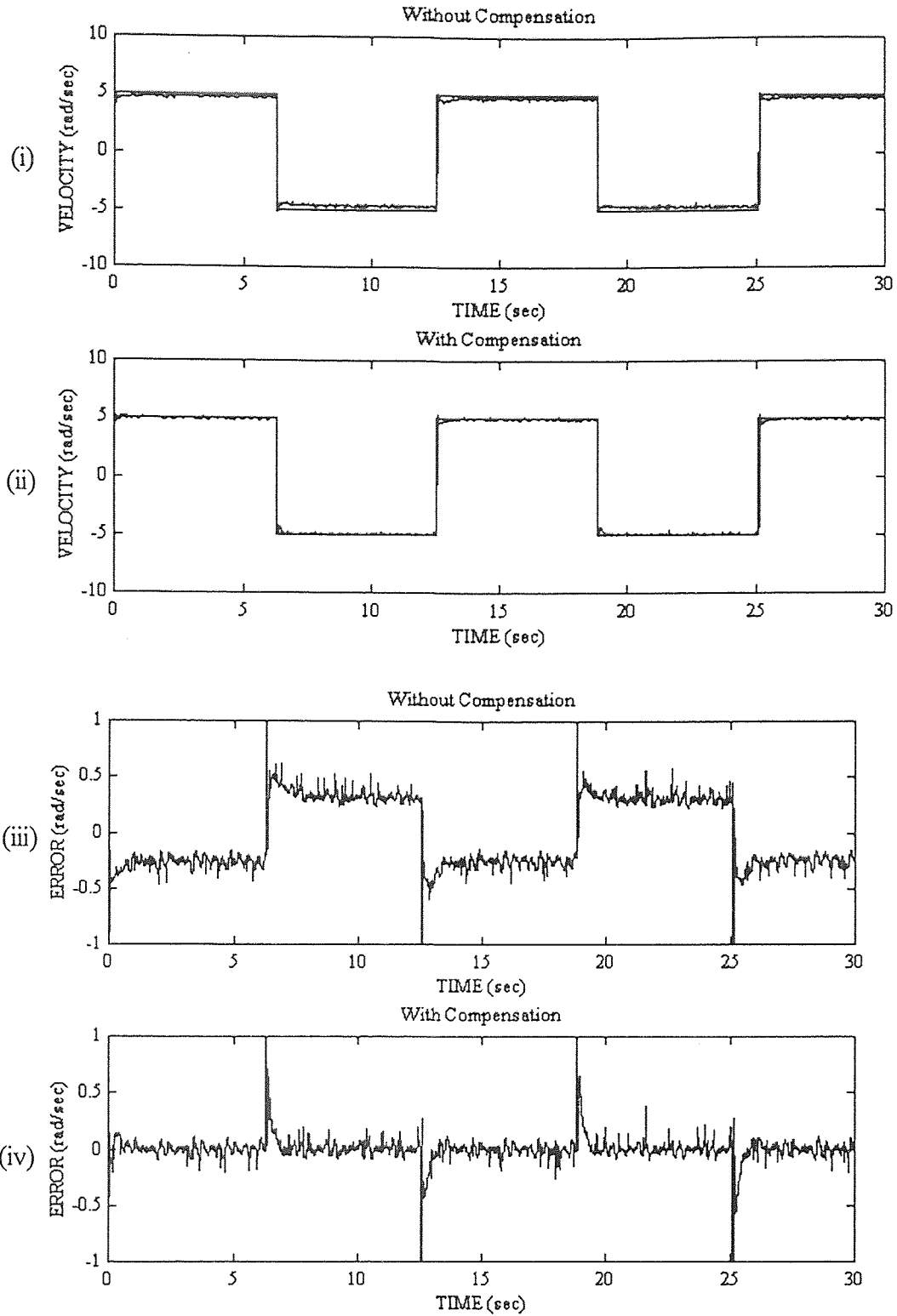
**Figure 5.4** Position control experiments - Square wave reference (i) Actual and reference position without friction compensation (ii) with friction compensation (iii) position error without compensation (iv) with compensation (v) estimated friction coefficient in time (vi) estimated friction v/s velocity.



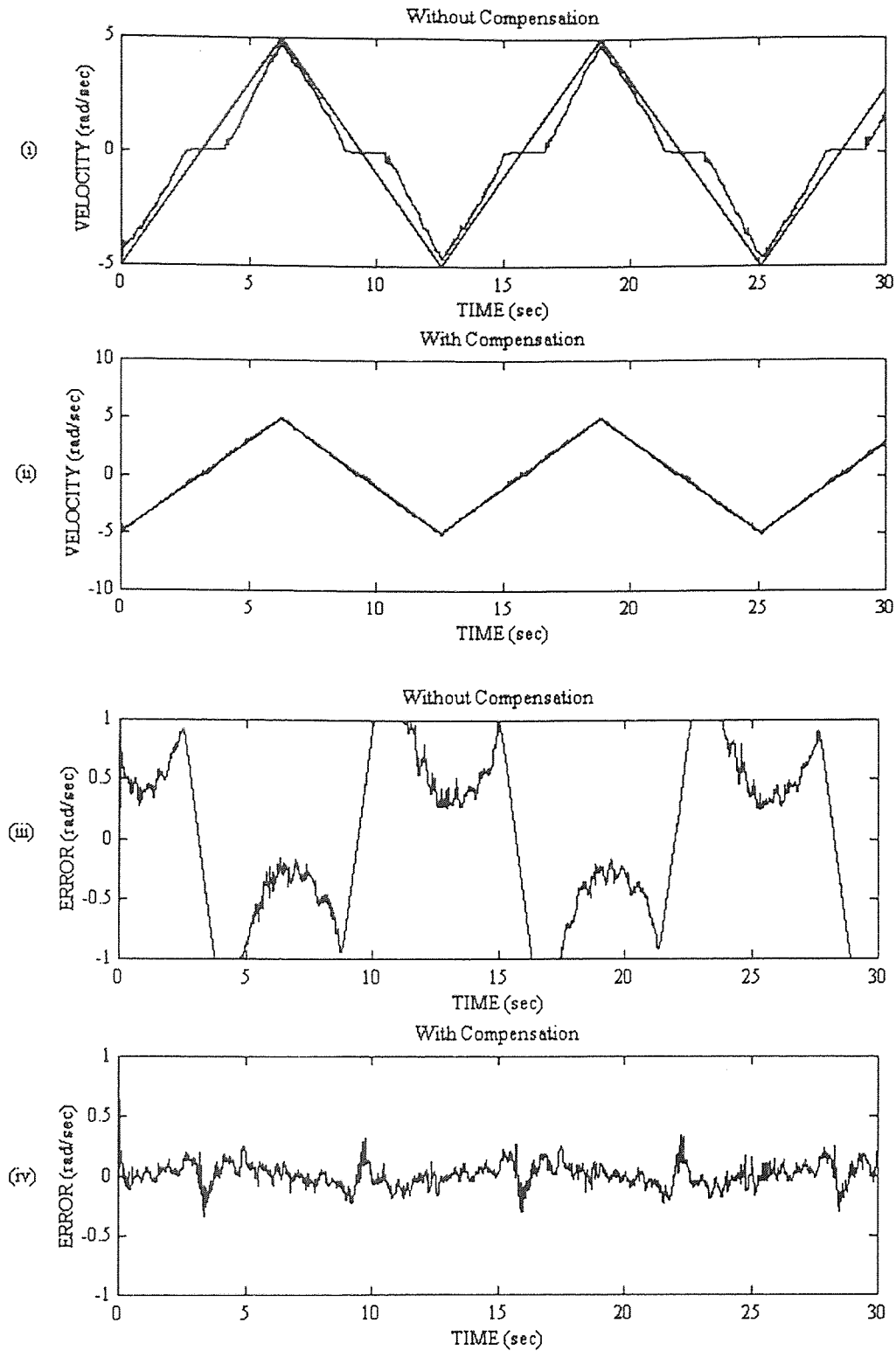
**Figure 5.5** Position control experiments - Triangular wave reference (i) Actual and reference position without friction compensation (ii) with friction compensation (iii) position error without compensation (iv) with compensation (v) estimated friction coefficient in time (vi) estimated friction v/s velocity.



**Figure 5.6** Position control experiments - Sinusoidal wave reference (i) Actual and reference position without friction compensation (ii) with friction compensation (iii) position error without compensation (iv) with compensation (v) estimated friction coefficient in time (vi) estimated friction v/s velocity.

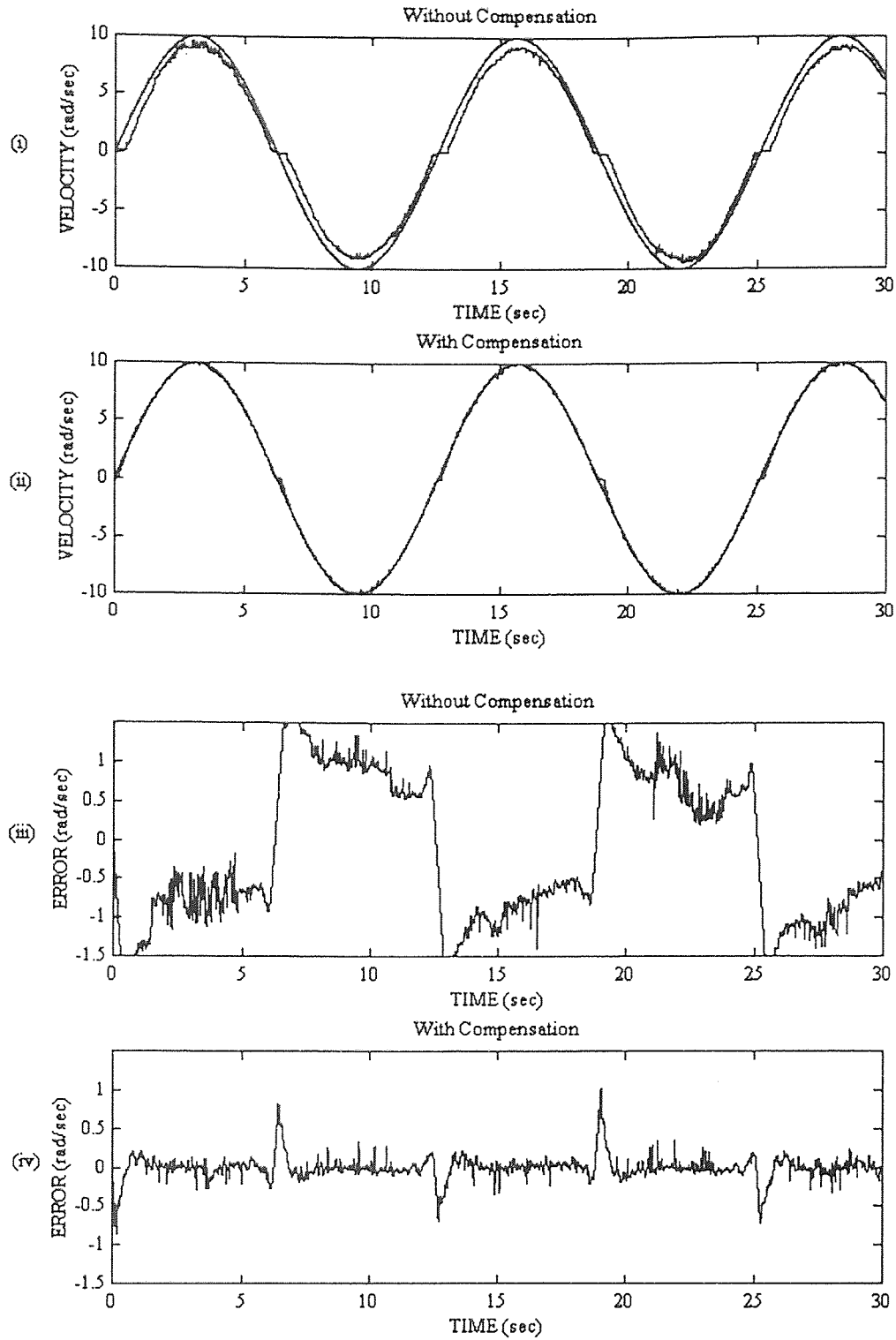


**Figure 5.7** Velocity control experiments - Square wave reference (i) Actual and reference velocity without friction compensation (ii) with friction compensation (iii) velocity error without compensation (iv) with compensation.

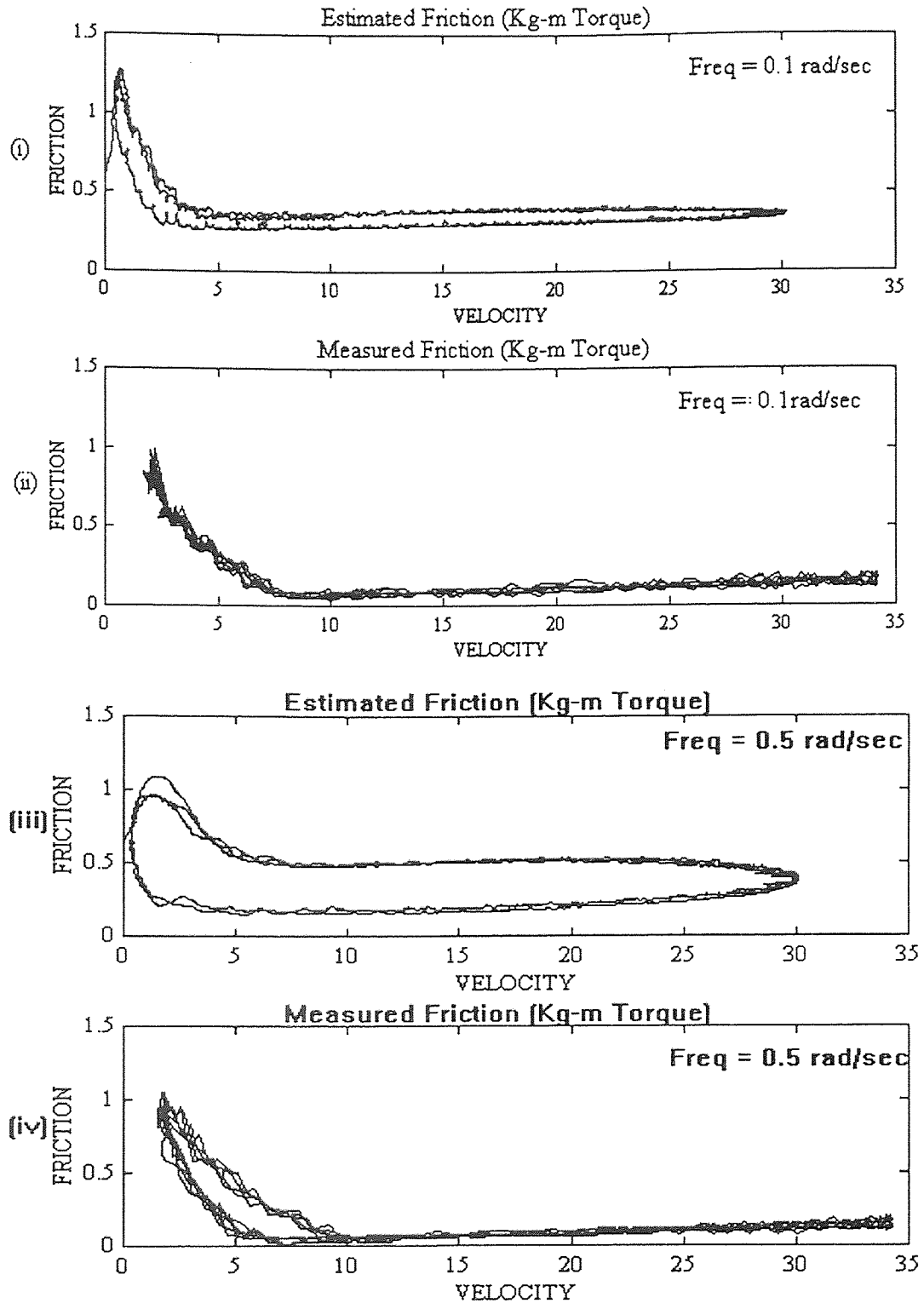


**Figure 5.8** Velocity control experiments - Triangular wave reference (i) Actual and reference velocity without friction compensation (ii) with friction compensation (iii) velocity error without compensation (iv) with compensation.

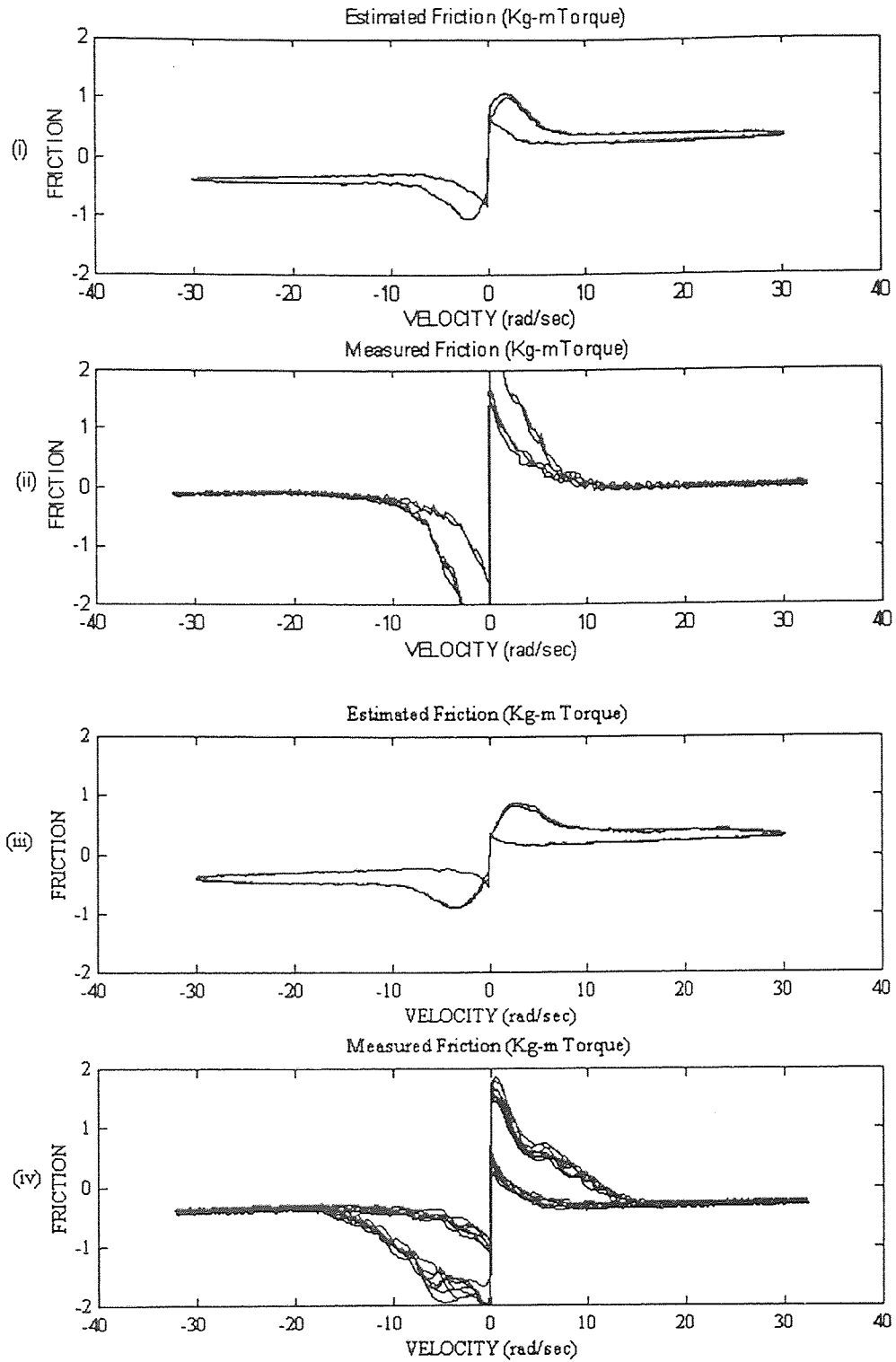




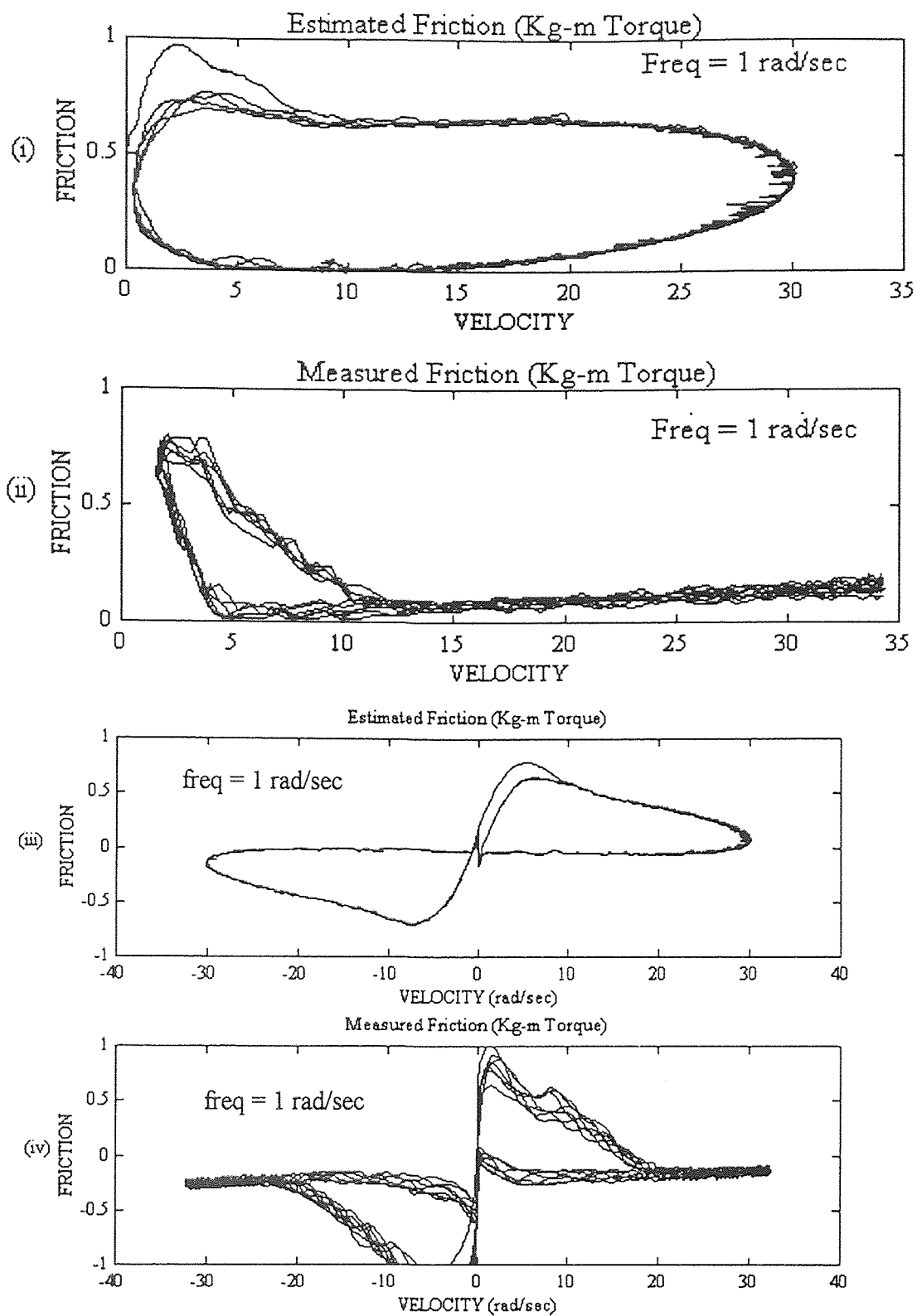
**Figure 5.9** Velocity control experiments - Triangular wave reference (i) Actual and reference velocity without friction compensation (ii) with friction compensation (iii) velocity error without compensation (iv) with compensation.



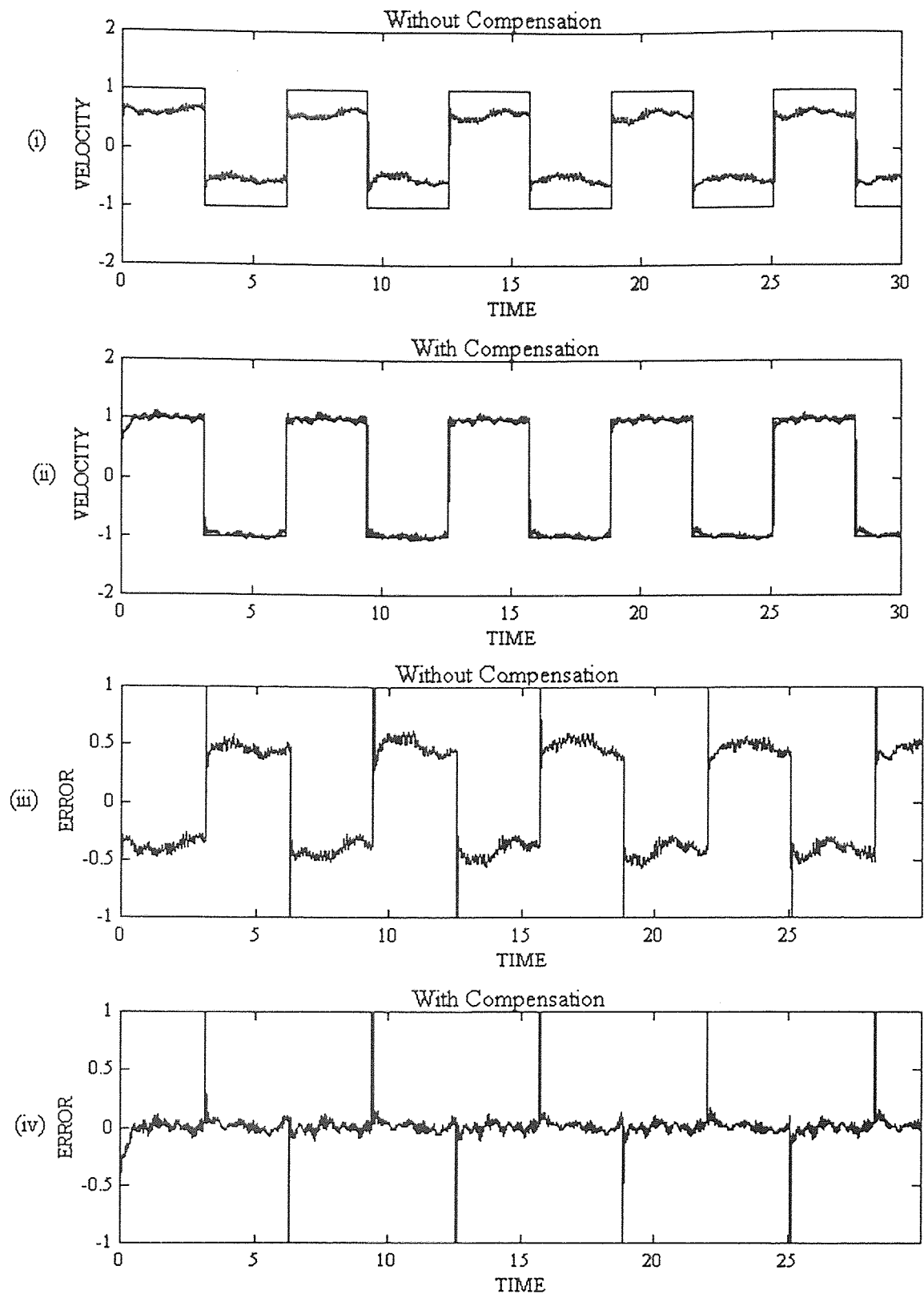
**Figure 5.10** Estimated friction and measured friction for unidirectional velocity (i) estimated friction and (ii) measured friction for  $\text{freq} = 0.1 \text{ rad/sec}$  (iii) estimated friction and (iv) measured friction for  $\text{freq} = 0.5 \text{ rad/sec}$ .



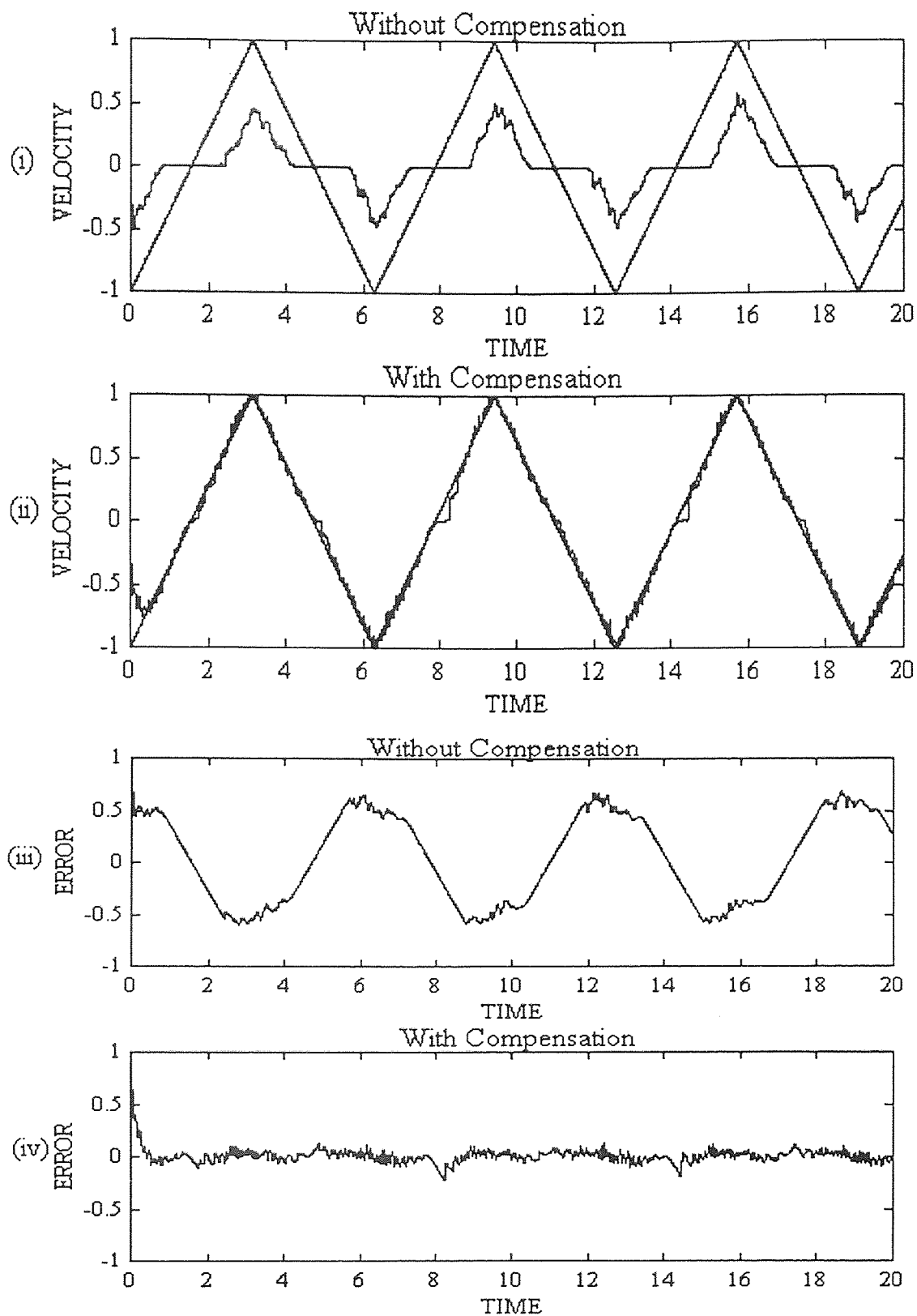
**Figure 5.11** Estimated friction and measured friction for bidirectional velocity (i) estimated friction and (ii) measured friction for  $\text{freq} = 0.1 \text{ rad/sec}$  (iii) estimated friction and (iv) measured friction for  $\text{freq} = 0.5 \text{ rad/sec}$ .



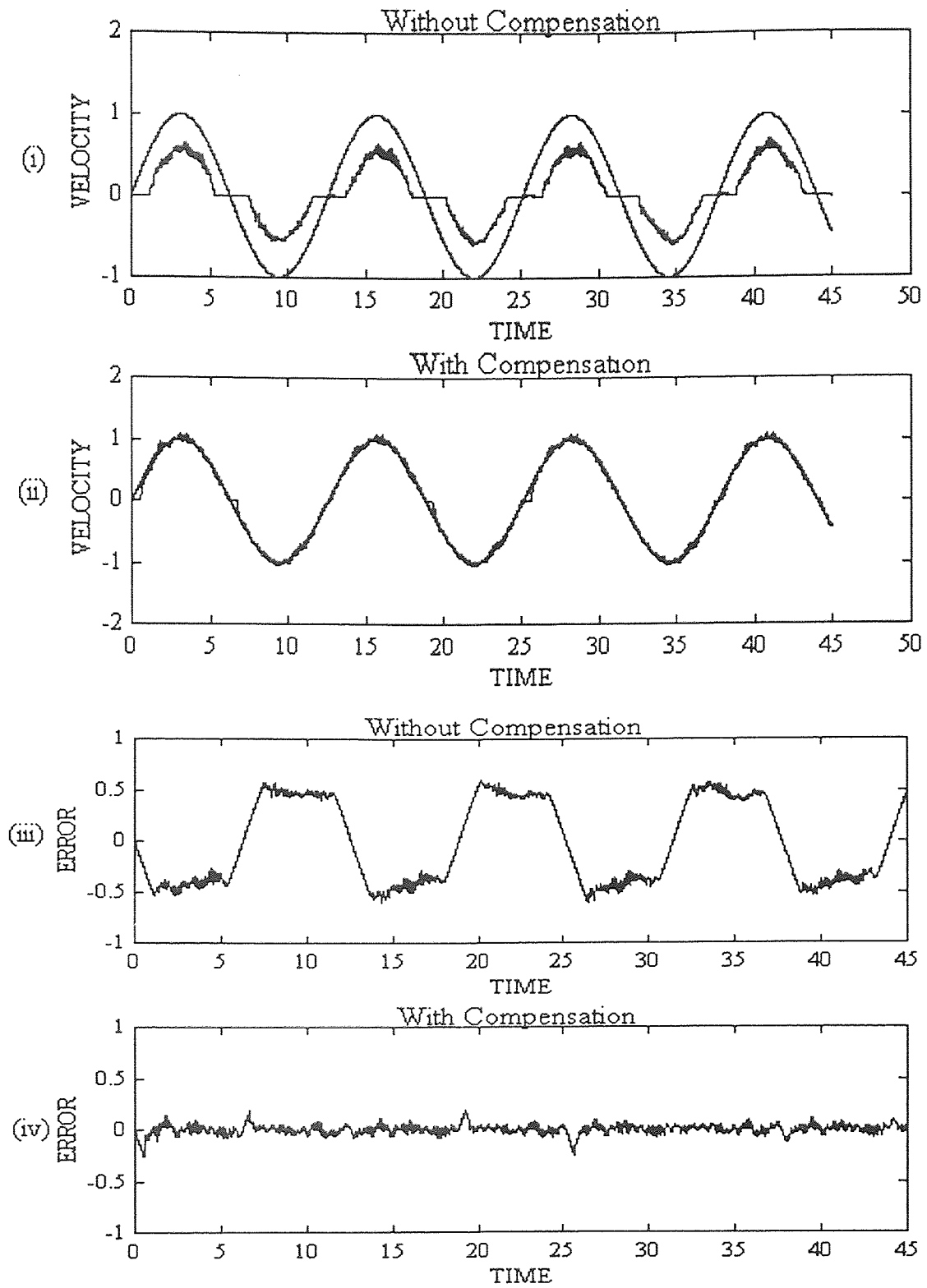
**Figure 5.12** Estimated friction and measured friction (i) estimated friction and (ii) measured friction for  $\text{freq} = 1 \text{ rad/sec}$  (iii) estimated friction and (iv) measured friction for bi-directional variations for  $\text{freq} = 1 \text{ rad/sec}$ .



**Figure 5.13** Very low velocity control experiments - Square wave reference signal (i) reference and actual velocity without friction compensation (ii) with compensation (iii) velocity error without compensation (iv) with compensation.



**Figure 5.14** Very low velocity control experiments - Triangular wave reference signal (i) reference and actual velocity without friction compensation (ii) with compensation (iii) velocity error without compensation (iv) with compensation.



**Figure 5.15** Very low velocity control experiments - Sinusoidal wave reference signal (i) reference and actual velocity without friction compensation (ii) with compensation (iii) velocity error without compensation (iv) with compensation.

## CHAPTER 6

### CONCLUSIONS AND FUTURE WORK

The experimental results for implementation of the Coulomb friction observer are given in the previous chapter. The results clearly demonstrate the improvement in system accuracy and performance by using the friction estimation and compensation technique.

Coulomb friction observer as given in its original form is shown to improve the system accuracy over an uncompensated system. However, better estimates for friction are obtained by using the recently proposed Tafazoli modification. The friction estimates obtained compare very well to the actually measured friction.

The ability to achieve extremely low velocities by utilizing the friction compensation technique is also demonstrated by experimental results.

The Coulomb friction observer has been already implemented and tested in its original form. Theoretical results for the same are also available. The extension of the observer for non-measurable velocities also has been theoretically investigated. However, the Tafazoli modification to the velocity observer, though experimentally justified, as in this work, has not yet been theoretically justified. More research needs to be done for justifying the modification using theoretical concepts.

Further, friction estimates obtained using the Coulomb observer need to be compared with those using more complex dynamic friction models. In particular, it needs to be investigated whether there is any advantage to be gained using more complex models and estimating more parameters.



## APPENDIX

### SOURCE CODE FOR THE ALGORITHMS

```
/* VCONTROL.C
   Written by: Jayesh Amin
   Last modified: Nov. 23 1995

   Source code for velocity control of the friction apparatus.
   Uses DACA board for I/O and requires to be linked to the modified
   version of the DACA library (modified by Jayesh on April 20th -
   available in Dynamic Systems Lab ).
   Uses LabWindows User Interface Library for GUI. vcontrol.uir contains
   the LabWindows resources and should be present in the same directory
   as this executable at run-time.
*/

#include <stdlib.h>
#include <math.h>
#include <stdio.h>
// DACA library header
#include <dacamu.h>
// Header file created by LabWindows
#include "control.h"

int hpanel, signal;           // Handle for panel and signal pointer
float low, high, freq, period; // Parameters for the signal generator
float (*sigfun)(void);       // Pointer for the ref. signal generator

float time=0.0, TS=0.002, totime=20.00; // Running time, Sampling Period and max
int n=0, i, compornot=1, nsamp=3;       // Sample Number, flag for indicating
// whether compensating or not.

float z=0, zd, prad=0, padd=0, zf=0, zfd, a; // Observer states and derivatives
float *u, *x1, *x2, *ref, *error, *tptr, *fric; // important sampled variable storage
float l=15.0, kf=.01; // Velocity and friction observer gains

int getcount(); // Returns the current count from the Encoder
float triagen(); // Reference signal generators
float squaregen();
float sinegen();

float sinphase=1.5708; // initial phase for sine generator
(for smooth start)

FILE *fp; // File pointer for storing data

void timerISR(); // Sampling and Control Routine (the
main engine!)
```

```

int main()
{
int done=0,sw=0,csw;           // some internal variables
int hp,hc;                    // Event Handles
void StartRun();              // Initializes everything at start of run
void StopRun();               // Cleans up the house after the run
void LatchParams();           // Latches critical parameters at start

hpanel=LoadPanel("control.uir",CONTROL);      // GUI Initialization
DisplayPanel(hpanel);
MessagePopup("Copyright, Jayesh '95"); // Fancy stuff !

u=(float*)malloc(sizeof(float)*4500);        // Allocate RAM for storage of
variables
x1=(float*)malloc(sizeof(float)*4500);
x2=(float*)malloc(sizeof(float)*4500);
ref=(float*)malloc(sizeof(float)*4500);
error=(float*)malloc(sizeof(float)*4500);
fric=(float*)malloc(sizeof(float)*4500);
if ((tpr=(float*)malloc(sizeof(float)*4500))==NULL)
{
    MessagePopup("Memory Allocation Problem - Not Enough memory !!");
    return 1;
}

BinaryWrite(0x0018);          // reset the encoder count to 0
AnalogWrite(0,2048);         // Reset D/A output to 0 V
LatchParams();                // Latch critical parameters

while(!done)                  // endless loop till it's all done
{
    if(GetUserEvent(0,&hp,&hc)); // Check for user actions
    switch(hc)
    {
        case(CONTROL_DONE):      // Its all done
            done=1;break;
        case(CONTROL_RUN):        // User toggled RUN switch
            GetCtrlVal(hpanel,CONTROL_RUN,&csw);
            if(sw==csw) break;
            sw=csw;
            if (sw)
                StartRun();
            else
                StopRun();
            break;
        case(CONTROL_TOTALTIME): // User changed total run-time
            GetCtrlVal(hpanel,CONTROL_TOTALTIME,&totime);
            nsamp=ceil(totime/10.0)+1;
            break;
        case(CONTROL_LOW):        // User changed low bound
of signal
            GetCtrlVal(hpanel,CONTROL_LOW,&low);

```

```

        if (high*low<0.0) sinphase=asin((high+low)/(high-low));
        else sinphase=1.5708;
        break;
    case(CONTROL_HIGH): // user changed high bound
        GetCtrlVal(hpanel,CONTROL_HIGH,&high);
        if (high*low<0.0) sinphase=asin((high+low)/(high-low));
        else sinphase=1.5708;
        break;
    case(CONTROL_FREQ): // frequency changed
        GetCtrlVal(hpanel,CONTROL_FREQ,&freq);
        period=1/(freq?freq:1); freq*=6.28;
        break;
    case(CONTROL_SIGNAL): // Type of reference
signal changed
        GetCtrlVal(hpanel,CONTROL_SIGNAL,&signal);
        switch(signal) // Set
appropriate signal generator
        {
            case(1): sigfun=squaregen; break;
            case(2): sigfun=triagen; break;
            case(3): sigfun=sinegen; break;
            default: break;
        }
        break;
    case(CONTROL_INPUT): // Show graph for
control input
        YGraphPopup(u,n-1,3);
        break;
    case(CONTROL_VELOCITY): // Plot sampled velocity
        YGraphPopup(x2,n-1,3);
        break;
    case(CONTROL_ERROR): // plot error
variable
        YGraphPopup(error,n-1,3);
        break;
    case(CONTROL_FRICTION): // plot estimated
friction
        YGraphPopup(fric,n-1,3);
        break;
    case(CONTROL_FRICVEL): // plot friction v/s velocity
        XYGraphPopup(x2,fric,n-1,3,3);
        break;

    case(CONTROL_POSPRINT): //print the main
graph
        OutputGraph(0,"",ConfirmPopup("Resize to fit page
?"),hpanel,CONTROL_POSITION);
        break;
    case(CONTROL_COMPORNOT): // toggle compensation/no-
compensation
        GetCtrlVal(hpanel,CONTROL_COMPORNOT,&compornot);
        break;
    default:

```

```

        break;
    } //endswitch(hc)
    if (sw) // If the motor is running
        if (time<=totime) // and time < total time required
        {
            SetCtrlVal(hpanel,CONTROL_TIME,time) ; // Update running-time box
        }
    else
    {
        SetCtrlVal(hpanel,CONTROL_RUN,sw=0); // Reset the run switch !!
        StopRun(); // Max. seconds over
    }
} // stop
}

} // endwhile(!done)
free(u);free(x1);free(x2); // release all the allocated
memory
free(ref);free(tptr);free(error); free(fric);
return 0;
}

// Initialization function before the run begins
// Its disables certain controls which are not usable while the
// apparatus is running. It also initializes control states.
void StartRun()
{
    fp=fopen("data.out","wt");
    time=n=z=zf=prad=padd=0.0;
    SetCtrlVal(hpanel,CONTROL_RUNLED,1); // Put on the LED

    // Disable unwanted controls !!
    SetInputMode(hpanel,CONTROL_POSPRINT,0);
    SetInputMode(hpanel,CONTROL_VELOCITY,0);
    SetInputMode(hpanel,CONTROL_FRICTION,0);
    SetInputMode(hpanel,CONTROL_ERROR,0);
    SetInputMode(hpanel,CONTROL_INPUT,0);
    SetInputMode(hpanel,CONTROL_TOTALTIME,0);
    SetInputMode(hpanel,CONTROL_FRICVEL,0);

    EnableISR(timerISR,TIMER,TS); // Start the timer
}

// Function invoked when the run finishes. It stops the timer, reenables
// the controls, plots new data and writes new data to the file.
void StopRun()
{
    DisableISR(); // Stop the Experiment (stop timer)

    // Reenable the controls
    SetInputMode(hpanel,CONTROL_VELOCITY,1);
    SetInputMode(hpanel,CONTROL_ERROR,1);
    SetInputMode(hpanel,CONTROL_INPUT,1);
}

```

```

SetInputMode (hpanel, CONTROL_POSPRINT, 1);
SetInputMode (hpanel, CONTROL_FRICTION, 1);
SetInputMode (hpanel, CONTROL_TOTALTIME, 1);
SetInputMode (hpanel, CONTROL_FRICVEL, 1);

SetCtrlVal (hpanel, CONTROL_RUNLED, 0); // Put off the LED
BinaryWrite(0x0018); // reset the encoder count to 0
AnalogWrite(0, 2048); // Reset D/A output to 0 V

// Clear the main graph and plot the new data
DeleteGraphPlot (hpanel, CONTROL_POSITION, -1, 0);
PlotXY (hpanel, CONTROL_POSITION, tptr, ref, n-1, 3, 3, 0, 0, 0);
PlotXY (hpanel, CONTROL_POSITION, tptr, x2, n-1, 3, 3, 0, 0, 0);

// store the data in the file
for (i=0; i<=n-1; i++)
    fprintf (fp, "%f6.3 %f5.2 %f5.2 %f6.2 %f5.2 %f7.4 %f9.4
\n", *(tptr+i), *(ref+i), *(x1+i), *(x2+i), *(u+i), *(error+i), *(fric+i));

fclose (fp);
}

// Function used for latching up the signal generator parameters from the
// GUI controls to internal variables.
void LatchParams ()
{
    GetCtrlVal (hpanel, CONTROL_LOW, &low); // Get the default signal
    GetCtrlVal (hpanel, CONTROL_HIGH, &high); // generator parameters
    GetCtrlVal (hpanel, CONTROL_FREQ, &freq);
    period=1/freq; freq*=6.28;
    GetCtrlVal (hpanel, CONTROL_SIGNAL, &signal);
    switch (signal)
    {
        case (1): sigfun=squaregen; break;
        case (2): sigfun=triagen; break;
        case (3): sigfun=sinigen; break;
        default: break;
    }
}

/*
void timerISR()
*** This is the main 'engine' for the control. It is a timer-interrupt service
routine.
it is invoked every TS seconds when enabled. This routine samples the
data and performs all the necessary calculations for the controller
and the observers.
note: the interrupts are generated by the timer on the DACA board.
*/
void timerISR()

```

```

{
static float tx1,tx2,tref,F,uf,ii=0;      // some internal variables

tref=(ref+n)=sigfun();                    // Calculate the reference signal
tx1=getcount()/2387.3;                    // Read counts and convert to radians

tx2=tx1-prad;                             // This is a mechanism to detect and
correct
if (tx2<-10) {padd+=27.45; tx2+=27.45;}   // the roll-over occurring in
else if (tx2>10) {padd-=27.45; tx2-=27.45;} // the encoder-count
prad=tx1;                                  // (by checking for sudden large
change in its value)
*(x1+n)=(tx1+=padd);

// Velocity observer
*(x2+n)=tx2=1*tx1+z;

*(error+n)=tx2-tref; // deviation error from the reference velocity

// Now the friction estimate
a=compornot*(zf-kf*(tx2<0?(-tx2):tx2));
*(fric+n)=F=a*(tx2>0?1:(tx2<0?-1:1));

// Control signal - proportional control and friction compensation
//   saturated at maximum of 10 volts (D/A limit)
*(u+n)=min(max((uf=-1.0*(tx2-tref)+0.295*tref)+F,-10),10);

// Scale the control signal for D/A and send it out.
AnalogWrite(0, (*(u+n))*204.7+2048);

// Velocity observer differential equation (integrated by first order Euler)
zd=-15.0*tx2;
z+=TS*zd;

// Friction observer differential equation (first order Euler integration)
zfd=kf*(457.0*(*(u+n)-F)-135*tx2)*(tx2<0?-1:1);
zf+=TS*zfd;

*(tptr+n)=time;    // update the current time
time+=TS;
if (++ii>=nsamp) {n++;ii=0;}

}

// This function gets the count from the encoder pulse counter
int getcount()
{
unsigned int lowb,highb;
BinaryWrite(0x0020);
highb=BinaryRead();
BinaryWrite(0x0028);
lowb=BinaryRead();
BinaryWrite(0x0030);
}

```

```

return ((highb&0xff00)+(lowb&0xff00)/256.0);
}

// The following functions generate the desired reference signals

/* Sine Wave generator */
float sinegen()
{
return((high+low+(high-low)*sin(freq*time-sinphase))/2);
}

/* Triangle Wave Generator */
float triagen()
{
float dtime;
dtime=time-(floor(time/period)*period);
if(dtime>period/2)
{
dtime-=period/2;
return(high-2*(high-low)*dtime/period);
}
else
{
return(low+2*(high-low)*dtime/period);
}
}

/* Square Wave generator */
float squaregen()
{
float dtime;
dtime=time-(floor(time/period)*period);
if(dtime>period/2)
return (low);
else
return (high);
}

/* The main routine from PCONTROL.C - program for position control
the other routines and functions are identical to VCONTROL.C .
This is the timer-interrupt service routine
*/
void timerISR()
{
static float tx1,tx2,tref,F,uf; // internal variables

tref=(ref+n)=sigfun(); // Calculate the reference signal
tx1=getcount()/2387.3; // Read count and convert to radians
tx2=tx1-prad;

```

```

if (tx2<-10) {padd+=27.45; tx2+=27.45;} // Mechanism to detect and correct a
count roll-over
else if (tx2>10) {tx2-=27.45; padd-=27.45;}
prad=tx1;
*(x1+n)=(tx1+=padd);

*(x2+n)=tx2=1*tx1+z; // Velocity observer

// Now friction estimate
*(fric+n)=a=compornot*(zf-kf*(tx2<0?(-tx2):tx2));
F=a*(tx2>0?1:(tx2<0?-1:1));
*(error+n)=tx1-tref; // deviation from the reference signal

uf=-k1*(tx1-tref)-k2*tx2; // feedback control law. (k1= 0.43764, k2= -0.25164)
if (uf>10) uf=10;
else if (uf<-10) uf=-10;

*(u+n)=uf+F; // Control Signal with compensation
if (*(u+n)>10) *(u+n)=10; // saturate at 10 volts
else if (*(u+n)<-10) *(u+n)=-10;

AnalogWrite(0, (*(u+n))*204.7+2048); // Output the Control Input signal

// velocity observer dynamics (first order Euler)
zd=-150.0*tx2+457.0*(uf);
z+=TS*zd;

// friction observer dynamics (first order Euler)
zfd=kf*(457.0*uf-135*tx2)*(tx2>0?1:(tx2<0?-1:0));
zf+=TS*zfd;

*(tptr+n)=time;
time+=TS;
n++;
}

```



## REFERENCES

- Amontons, G. 1699. "On the Resistance Originating in Machines." *Proceedings of the French Royal Academy of Sciences*, 206-222.
- Armstrong, B. 1988. "Dynamics for Robot Control: Friction Modeling and Ensuring Excitation during parameter identification." *Ph.D. Thesis*, Department of Electrical Engineering, Stanford University, Stanford.
- Armstrong-Hélouvry, B. 1991. Control of Machines with Friction. Boston, Kluwer Academic Press.
- . 1992. "A Perturbation Analysis of Stick-slip." In R. A. Ibrahim and A. Soom (Eds), *Friction-Induced Vibration, Chatter, Squeal, and Chaos, Proceedings of the ASME Winter Meeting*, Anaheim, DE, vol. 49: 41-48.
- . 1994. "A Survey of Models, Analysis Tools and Compensation Methods for the Control of Machines with Friction." *Automatica*, vol. 30, no. 7: 1083-1138.
- Bell, R., and M. Burdekin. 1966. "Dynamic Behaviour of Plain Sideways." *Proceedings of the Institution of Mechanical Engineers*, Vol. 181, pt. 1, no. 8: 169-183.
- Bell, R., and M. Burdekin. 1969. "A Study of the Stick-slip Motion of Machine Tool Feed Drives." *Proceedings of the Institution of Mechanical Engineers*, Vol. 184, pt. 1, no. 29: 543-560.
- Biel, C. 1920. "Die Reibung in Gliedlagern bei Zusatz von Voluten zu Mieralol und bei Veränderung der Unlaufzahl und der Temperatur." *Zeitschrift des Vereines Deutscher Ingenieure*, 4(1920): 449-483.
- Bo, L. C., and D. Pavelescu. 1982. "The Friction-Speed Relation and its Influence on the Critical Velocity of Stick-Slip Motion." *Wear*, 82: 277-289.
- Bogoliubov, N. N., and Y. A. Mitropolsky. 1961. Asymptotic methods in the Theory of Non-linear Oscillations. Gordon and Beach, NY.
- Brandenburg, G., and U. Schäfer. 1988. "Influence and Partial Compensation of Simultaneously Acting Backlash and Coulomb Friction in Position and Speed Controlled Elastic Two-mass System." *Proceedings of the 2nd International Conference on Electrical Drives, ICED*, Poicina Brasov.

- Brandenburg, G., and U. Schäfer. 1989. "Influence and Adaptive Compensation of Simultaneously Acting Backlash and Coulomb Friction in Elastic Two-mass Systems of Robots and Machine Tools." *International Conference on Control and Applications*, paper WA-4-5, IEEE, Jerusalem.
- Brandenburg, G., and U. Schäfer. 1991. "Influence and Compensation of Coulomb Friction in Industrial Pointing and Tracking Systems." *Proceedings of the Industrial Applications Society Annual Meeting*, IEEE, Dearborn, MI, 1403-1413.
- Canudas de Wit, C., K. J. Åström, and K. Braun. 1987. "Adaptive Friction Compensation in DC Motor Drives." *IEEE Journal of Robotics and Automation*, RA-3(6).
- Canudas de Wit, C., P. Noel, A. Aubin, and B. Brogliato. 1991. "Adaptive Friction Compensation in Robot Manipulators: Low-Velocities." *The International Journal of Robotics Research*, 10(3): 189-199.
- Canudas de Wit, C., H. Olsson, K. J. Åström, and P. Lischinsky. 1993. "Dynamic Friction Models and Control Design." *Proceedings of the 1993 American Control Conference*, AACC, San Francisco, CA, 1920-1926.
- Coulomb, C. A. 1785. "Théorie des Machines Simples, en Ayant égard au Frottement de Leurs Parties, et a la Roideur Dews Cordages." *Mémoire de Maths Physics*, x: 161-342.
- Craig, J. J. 1986. "Adaptive Control of Mechanical Manipulators." *Ph.D. Thesis*, Department of Electrical Engineering, Stanford University, Stanford, MA.
- Czichos, H. 1978. *Tribology*, Elsevier, Amsterdam.
- Dahl, P. R. 1976. "Solid Friction Damping of Mechanical Vibrations." *AIAA Journal*, 14(12): 1675-1682.
- DeWeerth, S. P., L. Nielsen, C. A. Mead, and K. J. Åström. 1991. "A Simple Neuron Servo." *IEEE Transactions on Neural Networks*, 2(2): 248-251.
- Dupont, P. E., 1993. "The Effect of Friction on the Forward Dynamics Problem." *International Journal of Robotics Research*, 12(2): 164-179.
- . 1993a. "Friction Modeling and Control in Boundary Lubrication." *Proceeding of 1993 American Control Conference*, AACC, San Francisco, CA, 1915-1919.
- . 1994. "Avoiding Stick-slip through PD Control." *IEEE Transactions on Automatic Control*, 39(5): 1059-1097.

- Friedland, B., F. M. Hutton, C. Williams, and B. Ljung. 1976. "Design of Servo for Gyro Test Table using Linear Optimum Control Theory." *IEEE Transactions on Automatic Control*, 4: 293-296.
- Friedland, B. 1986. Control System Design - An Introduction to State Space Methods. MacGraw Hill Publishing Company.
- Friedland, B., and S. E. Mentzelopoulou. 1992. "On Adaptive Friction Compensation Without Velocity Measurements." *Proceedings of the IEEE International Conference on Control Applications*, Dayton, OH, 2: 1076-1081.
- Friedland, B., and Y. J. Park. 1992. "On Adaptive Friction Compensation." *Proceedings of the 30th IEEE Conference on Decision and Control*, Brighton, England, 2899-2903.
- Fuller, D. D. 1984. Theory and Practice of Lubrication for Engineers. John Wiley and Sons, NY.
- Gilbart, J. W., and G. C. Winston. 1974. "Adaptive Compensation for an Optical Tracking Telescope." *Automatica*, 10(2), 125-31.
- Haessig, D. A., and B. Friedland. 1991. "On the Modeling and Simulation of Friction." *Journal of Dynamic Systems, Measurement and Control*, 113(3): 354-362.
- Hansson, A., P. Gruber, and J. Todtli. 1993. "Fuzzy Anti-reset Windup for PID Controllers." *Proceedings of the World Congress on Automatic Control*, IFAC, Sidney, Australia.
- Harnoy, A., B. Friedland, R. Semenoek, H. Rachoor, and A. Aly. 1994. "Apparatus for Empirical Determination of Dynamic Friction." *Proceedings of the 1994 American Control Conference*, ACC, Baltimore, MD, 546-550.
- Harnoy, A., and B. Friedland. 1993. "Dynamic Friction Model of Lubricated Surfaces for Precise Motion Control." *Proceedings of the STLE/ASME Tribology Conference*, New Orleans, Louisiana.
- Harnoy, A., B. Friedland, and H. Rachoor. 1994. "Modeling and Simulation of Elastic and Friction Forces in Lubricated Bearings for Precise Motion Control." *Wear*.
- Hess, D. P., and A. Soom. 1990. "Friction at a Lubricated Line Contact Operating at Oscillating Sliding Velocities." *Journal of Tribology*, 112(1): 147-152.

- Hojjat, Y., and T. Higuchi. 1991. "Application of Electromagnetic Impulsive Force to Precise Positioning." *International J. Japan Soc. Precision Engineering*, 25(1): 45-50.
- Johnson, C. T., and R. D. Lorenz. 1991. "Experimental Identification of Friction and Its Compensation in Precise, Position Controlled Mechanisms." *Proceedings of the Industrial Applications Society Annual Meeting*, Dearborn, MI, 1400-1406.
- Karnopp, D. 1985. "Computer Simulation of Stick-slip Friction in Mechanical Dynamic Systems." *Measurement and Control*, 107(1): 100-103.
- Kato, S., and T. Matsubayashi. 1970. "On the Dynamic Behavior of Machine Tool Slideway." *Bulletin of the Japanese Society of Mechanical Engineers*, 13(55): 170-198.
- Kato, S., K. Yamaguchi, and T. Matsubayashi. 1974. "Stick-slip Motion of Machine Tool Slideway." *ASME Journal of Engineering for Industry*, 96(2): 557-466.
- Kubo, T., G. Anwar, and M. Tomizuka. 1986. "Application of Nonlinear Friction Compensation to Robot Arm Control." *Proceedings of the 1986 International Conference of Robotics and Automation*, IEEE, San Francisco, CA, 722-727.
- Kuc, T. Y., K. Nam, and J. S. Lee. 1991. "An Iterative Learning Control of Robot Manipulators." *Transactions on Robotics and Automation*, 7(6): 835-842.
- Maqueira, B., and M. K. Masten. 1993. "Adaptive Friction Compensation for Line-of-sight Pointing and Stabilization." *Proceedings of the 1993 American Control Conference*, ACC, San Francisco, CA, 1942-1946.
- Mentzelopoulou, S. 1994. "Estimation and Cancellation of Friction in Control Systems." *Ph.D. Dissertation*, Department of Electrical and Computer Engineering, New Jersey Institute of Technology, Newark.
- Morin, A.J. 1833. "New Friction Experiments carried out at Metz in 1831-1833." *Proceedings of the French Royal Academy of Sciences*. 4: 1-128.
- Polycarpou, A., and A. Soom. 1992. "Transitions between Sticking and Slipping." In R. A. Ibrahim and A. Soom (Eds.), *Friction-induced Vibration, Chatter, Squeal and Chaos. Proceedings of the ASME Winter Annual Meeting*, Anaheim, DE-Vol. 49, ASME, NY, 139-148.
- Rabinowicz, E. 1958. "The Intrinsic Variables Effecting the Stick-slip Process." *Proceedings of the Physical Society of London*, 71(4): 668-675.

- . 1959. "A Study of Stick-slip Process." In R. Davies (Ed.), *Friction and Wear*, Elsevier, NY.
- . 1965. *Friction and Wear of Materials*, John Wiley and Sons, NY.
- Reynolds, O. 1886. "On the Theory of Lubrication and Application to Mr. Beauchamp Tower's Experiments, including an Experimental Determination of the Viscosity of Olive Oil." *Philosophical Transactions of Royal Society*, 177: 157-234.
- Rice, J. R., and A. L. Ruina. 1983. "Stability of Steady Frictional Slipping." *Journal of Applied Mechanics*, 50: 343-349.
- Ruina, A. 1980. "Friction Laws and Instabilities: a Quasistatic Analysis of some Dry Frictional Behavior." *Ph.D. Dissertation*, Division of Engineering, Brown University.
- Sampson, J. B., F. Morgan, D. W. Reed, and M. Muskat. 1943. "Friction Behavior during the Slip portion of the Stick-slip Process." *Journal of Applied Physics*, 14(12): 689-700.
- Schäfer, U., and G. Brandenburg. 1989. "Model Reference Position Control of an Elastic Two-mass System with Backlash and Coulomb Friction using Different Types of Observers." *Power Electronics and Motion Control, PEMC*, Budapest, vol. 3: 797-801.
- Shen, C. N., and H. Wang. 1964. "Nonlinear Compensation of a Second- and Third-order System with Dry Friction." *IEEE Transactions on Applications and Industry*, 83(71): 128-136.
- Singh, B.R. 1960. "Study of Critical Velocity of Stick-slip Sliding." *Journal of Engineering for Industry*, 393-398.
- Stribeck, R. 1902. "Die Wesentlichen Eigenschaften der Gleit und Rollenlager - the key qualities of sliding and roller bearings." *Zeitschrift des Vereines Seutscher Ingenieure*, 46(38): 1342-1348; 46(39): 1432-1437.
- Suzuki, A., and M. Tomizuka. 1991. "Design and Implementation of Digital Servo Controller for High Speed Machine Tools." *Proceedings of the 1991 American Control Conference*, AACC, Boston, WA, 1246-1251.
- Tafazoli, S., C. W. de Silva, and P. D. Lawrence. 1995. "Friction Estimation in a Planar Electrohydraulic Manipulator." *Proceedings of the 1995 American Control Conference*, ACC, Seattle, WA, vol. 5 of 6: 3294-3298.

- Townsend, W. T., and J. K. Salisbury. 1987. "The Effect of Coulomb Friction and Stiction on Force Control." *Proceedings of the 1987 International Conference on Robotics and Automation*, IEEE, Raleigh, 883-889.
- Tustin, A. 1947. "The Effects of Backlash and of Speed-dependent Friction on the Stability of Closed-cycle Control Systems." *IEEE Journal*, 94(2A): 143-151.
- Walrath, C. D. 1984. "Adaptive Bearing Friction Compensation based on Recent Knowledge of Dynamic Friction." *Automatica*, 20(6): 717-727.
- Wu, C. H., and R. P. Paul. 1980. "Manipulator Compliance based on Joint Torque Control." *19th Conference on Decision and Control*, IEEE, Albuquerque, NM, 89-94.
- Yang, S., and M. Tomizuka. 1988. "Adaptive Pulse Width Control for Precise Positioning under the Influence of Stiction and Coulomb Friction." *ASME Journal of Dynamic Systems, Measurement and Control*, 110(3): 221-227.