

## **Copyright Warning & Restrictions**

The copyright law of the United States (Title 17, United States Code) governs the making of photocopies or other reproductions of copyrighted material.

Under certain conditions specified in the law, libraries and archives are authorized to furnish a photocopy or other reproduction. One of these specified conditions is that the photocopy or reproduction is not to be “used for any purpose other than private study, scholarship, or research.” If a user makes a request for, or later uses, a photocopy or reproduction for purposes in excess of “fair use” that user may be liable for copyright infringement,

This institution reserves the right to refuse to accept a copying order if, in its judgment, fulfillment of the order would involve violation of copyright law.

**Please Note: The author retains the copyright while the New Jersey Institute of Technology reserves the right to distribute this thesis or dissertation**

Printing note: If you do not wish to print this page, then select “Pages from: first page # to: last page #” on the print dialog screen

The Van Houten library has removed some of the personal information and all signatures from the approval page and biographical sketches of theses and dissertations in order to protect the identity of NJIT graduates and faculty.

**EFFECTS OF ERGONOMIC WORKSITE CHANGES ON RISKS FOR  
CUMULATIVE TRAUMA DISORDERS OF THE UPPER BODY  
IN AN ASSEMBLY AND PRESS OPERATION JOB**

by  
**David B. Mahone**

Cumulative trauma of the upper body is associated with a variety of individual and job factors. An effort to optimize the human-hardware interface to minimize cumulative trauma is favored. Workers in a set of jobs had complained about hand/wrist and shoulder discomfort. One job was selected for testing alternate machine controls and worksite layout. Electromyography was used to test muscle activity, and photogoniometry was used to measure posture.

For the group of ten worker-subjects, statistically significant decreases in hand/wrist and shoulder muscle activity were found. A marginal, but significant increase in neck muscle activity was also found. When one subject was excluded, improvements were unchanged and the increase in neck muscle activity was not significant for three of four types of analysis of variance. While statistical improvement was identified, the question of clinical significance cannot be answered at this time.

**EFFECTS OF ERGONOMIC WORKSITE CHANGES ON RISKS FOR  
CUMULATIVE TRAUMA DISORDERS OF THE UPPER BODY  
IN AN ASSEMBLY AND PRESS OPERATION JOB**

by  
**David B. Mahone**

**A Thesis  
Submitted to the Faculty of  
New Jersey Institute of Technology  
in Partial Fulfillment of the Requirements for the Degree of  
Master of Science in Industrial Engineering**

**Department of Mechanical and Industrial Engineering**

**May 1995**

**APPROVAL PAGE**

**EFFECTS OF ERGONOMIC WORKSITE CHANGES ON RISKS FOR  
CUMULATIVE TRAUMA DISORDERS OF THE UPPER BODY  
IN AN ASSEMBLY AND PRESS OPERATION JOB**

**David B. Mahone**

---

Dr. Howard Gage, Thesis Advisor date  
Professor of Industrial Engineering, NJIT

---

Dr. Thomas Spencer III, Committee Member date  
District Manager, Business Operations  
AT&T Bell Laboratories  
Adjunct Professor, NJIT

---

Dr. David Kristol, Committee Member date  
Director of Biomedical Engineering Program  
Professor of Chemistry, NJIT

Blank Page

## BIOGRAPHICAL SKETCH

**Author:** David B. Mahone

**Degree:** Master of Science in Industrial Engineering

**Date:** May 1995

### **Undergraduate and Graduate Education:**

- Master of Science in Industrial Engineering,  
New Jersey Institute of Technology, Newark, NJ, 1995
- Bachelor of Science in Industrial Engineering and Operations Research,  
Virginia Polytechnic Institute and State University, Blacksburg, VA, 1987

### **Presentations and Publications:**

Mahone, David B., "Review of System Designs Employs Ergonomics Prior to Work Injuries", *Occupational Health & Safety* - May 1993

Mahone, David B., "Ergonomic Quick-Fix Solutions - Watch Out!", *Industrial Engineering* - July 1993

Mahone, David B., "Evaluating Quick-Fix Solutions to Ergonomic-Related Hazards", *Professional Safety* - September 1993

Mahone, David B., "Ergonomics in the Design/Selection of Small Scale Systems", *Professional Safety* - November 1993

Mahone, David B., "Work Sampling as a Method for Assessing Cumulative Trauma Disorders", *Proceedings of the Human Factors and Ergonomics Society Annual Meeting*, 1993

## ACKNOWLEDGMENT

The author wishes to express sincerest thanks to Professors Howard Gage and Thomas Spencer III for their guidance and support, their knowledge and wisdom, and most of all, for encouraging excellence by offering excellence. Also thanks to Dr. Kristol for his participation.

I am grateful to Ruth Martin and Al Brown of Texas Instruments for their help and support with the experiment and subjects. A special thanks to all of the patient and cooperative subjects who participated, and to the department group leaders who helped coordinate subjects for data collections.

The author also acknowledges the help and support of B.J. Littleton and Joan Everson of Continental Insurance, and the support of Corporate Loss Control, Continental Insurance. Additional thanks to Larry Duke and Mark O'Brian of Texas Instruments. This project was supported by Texas Instruments and Continental Insurance.



## TABLE OF CONTENTS

<b>Chapter</b>	<b>Page</b>
1 INTRODUCTION.....	1
2 LITERATURE SURVEY.....	4
2.1 Work and Upper Body Cumulative Trauma Disorders.....	4
2.2 Non-Work Factors and Upper Body CTDs.....	5
2.3 Work Factors Versus Personal Factors.....	6
2.4 Assessment of Occupational Factors.....	9
2.4.1 Task Repetitiveness and CTDs.....	9
2.4.2 Working Postures and CTDs.....	10
2.4.3 Forceful Exertions and CTDs.....	15
2.4.4 Mechanical Stresses and CTDs.....	16
2.4.5 Temperature and CTDs.....	16
2.4.6 Vibration Exposure and CTDs.....	17
2.5 Assessment of Individual Factors.....	17
2.5.1 Anthropometric Dimensions and CTDs.....	17
2.5.2 Body Mass and CTDs.....	19
2.5.3 Gender and CTDs.....	20
2.5.4 Smoking and CTDs.....	21
2.5.5 Age and CTDs.....	21
2.5.6 Psychological Factors and CTDs.....	23
2.5.7 Exercise and CTDs.....	24

**TABLE OF CONTENTS**  
**(continued)**

<b>Chapter</b>	<b>Page</b>
2.5.8 Other Individual Factors.....	26
2.5.9 Disorders - Described with Associated Activities.....	26
3 RESEARCH OBJECTIVES.....	29
4 MATERIALS AND EXPERIMENTAL METHODS.....	31
4.1 Variables.....	31
4.2 Subjects.....	32
4.3 Force Measurement - EMG.....	32
4.4 Muscle Groups.....	34
4.5 Electrode Placements.....	36
4.6 Variability.....	36
4.7 Pilot Results.....	37
4.8 Data Smoothing.....	39
4.9 Design of Experiment - EMG.....	39
4.10 Posture Measurement - Work Sampling.....	40
4.11 Design of Experiment - Postural Analysis.....	41
4.12 Possible Confounders.....	45
4.12.1 Fatigue Effects.....	45
4.12.2 Learning Effects.....	45
4.12.3 Presentation Order Effects.....	46

**TABLE OF CONTENTS**  
(continued)

<b>Chapter</b>	<b>Page</b>
4.13 Subjective Data Collection.....	46
4.14 Workstation Design Changes.....	47
4.15 Expected Results.....	55
4.16 Statistical Analysis.....	56
5 RESULTS.....	58
5.1 EMG.....	58
5.2 Distributions.....	63
5.3 Posture.....	64
5.4 Symptoms.....	66
5.5 Discussion.....	66
5.6 Conclusions and Recommendations.....	68
APPENDICES-	
A Examples of Data Distribution Goodness of Fit Chi-Square Tests.....	71
B Examples of Raw, Smoothed, and Savitzsky-Golay Filtered Data.....	75
C Symptoms Survey Results.....	79
D Examples of General Linear Model, ANOVAs and Means Tests.....	84
E Workstation Details.....	110
F Posture Results.....	120
REFERENCES.....	123

## LIST OF TABLES

<b>Table</b>	<b>Page</b>
1 Common Repetitive Strain Injuries.....	28
2 Sample Sizes per Subject and Condition (EMG).....	34
3 Hand/Wrist Differences in Mean Muscle Activity.....	58
4 ANOVA Results - Hand/Wrist.....	61
5 Means Test - Hand/Wrist.....	62
6 ANOVA Results - Shoulder, Raw Data.....	94
7 Means Test - Shoulder, Raw Data.....	95
8 ANOVA Results - Shoulder, Smoothed Data.....	96
9 Means Test - Shoulder, Smoothed Data.....	97
10 ANOVA Results - Neck.....	98
11 ANOVA Results - Neck (Subject 10 Excluded).....	99
12 Means Test - Neck (Subject 10 Excluded).....	100
13 Posture Results - Hand/Wrist.....	65
14 Posture Results - Shoulder.....	121
15 Posture Results - Neck.....	122
16 Symptoms Results - Summary.....	66

## LIST OF FIGURES

<b>Figure</b>	<b>Page</b>
1 Long-Term Sick-Leave Before/After Ergonomic Changes.....	13
2 Labor Turnover Before/After Ergonomic Changes.....	13
3 Motion Index, Posture Symptoms Graph.....	14
4 Body Mass Index and Slowed Nerve Conduction.....	19
5 Gender and CTD Cases.....	21
6 Age-Sex and CTD Cases.....	22
7 Personality Profile and CTDs.....	23
8 Extensor Digitorum (hand/wrist muscle group).....	34
9 Deltoid (shoulder muscle group).....	35
10 Upper Trapezius.....	35
11 Plot of Raw Data Per Muscle Group (over 10 cycles).....	38
12 Photogoniometric Angle - Wrist Flexion.....	42
13 Photogoniometric Angle - Shoulder Flexion.....	43
14 Photogoniometric Angle - Head/Neck Flexion.....	44
15 Old Workstation - Side View.....	52
16 Old Workstation - Shoulder Flexion.....	53
17 Old Workstation - Wrist Flexion.....	54
18 Subject 1 - EMG Results, Raw.....	60
19 Subject 2 - EMG Results, Raw.....	85

**LIST OF FIGURES**  
**(continued)**

<b>Figure</b>	<b>Page</b>
20 Subject 4 - EMG Results, Raw.....	86
21 Subject 5 - EMG Results, Raw.....	87
22 Subject 5 - EMG Results, Smoothed.....	88
23 Subject 6 - EMG Results, Raw.....	89
24 Subject 7 - EMG Results, Raw.....	90
25 Subject 8 - EMG Results, Raw.....	91
26 Subject 9 - EMG Results, Raw.....	92
27 Subject 10 - EMG Results, Raw.....	93

## CHAPTER 1

### INTRODUCTION

Occupational cumulative trauma disorders (CTDs) - or repetitive motion disorders - are a growing problem in American industry. Such disorders constituted slightly greater than 60% of all occupational illnesses in 1991 according to the Bureau of Labor Statistics (BLS), exceeding all other categories of occupational illness. The BLS category "disorders due to repeated trauma" also included noise induced hearing loss, making meaningful interpretation of the data difficult. Brogmus and Marko (1992) report that upper body CTDs constituted only 3.5% of all workers compensation costs in 1991. This can be contrasted with the impact that back injuries have on workers compensation costs, with 31.2% (NCCI, 1992) of all compensation costs going for back injuries.

Nevertheless, many manufacturing and service industry companies have clearly experienced substantial losses when workers have been affected by upper body CTDs. Some industries appear to be more commonly affected. Meat packers have seen an estimated 28.8% of all compensation costs go to upper body CTDs, while knit goods or hosiery manufacturers have seen 18.3% of compensation costs go to upper body CTDs (Brogmus and Marko, 1992). Such cost estimates include insured costs only. In addition to insured costs, uninsured or indirect losses include reduced productivity and morale, loss of valued workers, poor product quality, increased absenteeism and turnover, and reduced systems reliability, among other costs.

A wide range of industries or jobs have been significantly affected. In one survey, 64.5% of supermarket checkout workers who used scanners reported symptoms of carpal tunnel syndrome (Margolis and Kraus, 1987). Brogmus and Marko (1990) report that after meat packers, hardware manufacturers, electrical apparatus manufacturing, clothing/textiles, electrical power or transmission equipment manufacturers, paper bag manufacturers, and computer/office machine manufacturers, among others, are substantially affected by CTDs. A common theme among affected industries is the reliance on hand work.

Included in the list of affected industries are manufacturers of electric and electronic components including switches, controls, and circuit breakers. Workers in electrical and electronics manufacturing primarily engage in intensive hand work, often performing short-cycle repetitive tasks, sometimes with forceful or sustained exertions, and often in awkward postures.

The objective of this study is to test the effects of specific physical changes at a worksite in the electrical apparatus industry on CTD risks. The selected job is a repetitive assembly and press operation task in which parts are assembled and inserted to a press machine, then press controls are activated and the completed part is removed. Measures of CTD risks to workers using the existing workstation will be compared to the same measures taken after the workstation has been redesigned in accordance with ergonomic principles.

Since direct measures of CTD risks are not currently available, secondary measures are utilized to assess risks for upper body CTDs. Surface electromyography (EMG) is utilized to assess muscular activity and thus the force or work required to complete the job.



Force level is generally acknowledged in the literature as an important contributor to risk for upper body CTDs (Armstrong and Chaffin, 1979; Silverstein, Fine, and Armstrong, 1987; Armstrong et al. 1987a).

Posture of the hand/wrist is also acknowledged as an important contributor to risk for upper body CTDs (Armstrong and Chaffin, 1979; Tichauer, 1966). Work sampling - by placing selected body postures into predefined posture categories - is to be utilized as a measure of postural stress over time.

While force, posture, repetitiveness and other factors are generally recognized as work-related factors which can increase the risks for upper body CTDs, a need to document successful application of ergonomic improvements in specific worksites exists. General design guidelines can be gleaned from such empirical applications where successful.

However, personal factors such as age, gender, obesity, handedness, and medical condition, among others, have also been correlated with increased risk of upper body CTD (Nathan, Keniston, Myers, and Meadows, 1992). Some controversy currently exists as to whether or not such disorders are caused by repetitive and/or forceful work versus non-work related causes.

The following literature review explores the current controversy regarding upper body CTDs and provides an overview of research findings to date.

## CHAPTER 2

### LITERATURE SURVEY

#### 2.1 Work and Upper Body Cumulative Trauma Disorders

Silverstein, Fine, and Armstrong (1987) discovered a significantly higher proportion of 652 industrial workers in high force, high repetitive jobs were affected by carpal tunnel syndrome compared to workers in low force, low repetitive jobs. Armstrong et al. (1987) in a related study, found the prevalence of hand and wrist tendinitis to be 29 times greater in persons who perform high force, high repetitive jobs than persons performing low force, low repetitive jobs. Except for gender, none of the examined non-occupational factors were significantly associated with prevalence of disorders. The authors speculate that a large proportion of women in a clinical series may reflect more the social and reporting differences between males and females than an inherent difference in risk.

Additionally, the researchers found significant differences in time spent in wrist flexion, ulnar deviation, pinching, and flexion with pinching between males and females, and suggest that this may explain, at least in part, the significant difference found for gender. Interestingly, the researchers found no significant difference in postural variables between persons affected with tendinitis and those unaffected by tendinitis, suggesting that perhaps repetition and force were important to development of tendonitis, but that posture may be of lesser importance.

## 2.2 Non-Work Factors and Upper Body CTDs

Nathan et al. (1992) pursued a longitudinal study of carpal tunnel syndrome in industry over a five year period. These researchers found strong positive correlations between weight and body mass index and electrodiagnostic indicators of carpal tunnel syndrome risk. The study also found that age, wrist depth/width ratio, hand dominance, and exercise level were associated with electrodiagnostic indicators of carpal tunnel syndrome, while occupational hand use, duration of employment, or industry were not associated with electrodiagnostic indicators of carpal tunnel syndrome. Obesity was associated with an increased prevalence of carpal tunnel syndrome.

Similarly, no relatedness between sensory nerve conduction velocity and work factors (e.g., hand use, length of employment) was found in a survey of 471 industrial workers from 27 occupations conducted by Nathan, Meadows, and Doyle (1988). This negative finding was emphasized by the authors who noted that the prevalence and severity of sensory impairment among the diverse occupational classes were comparable, suggesting that carpal tunnel syndrome is not related to occupational hand activity.

In a study of poultry processing workers, Schotland et al. (1991) found no association between length of employment and sensory latencies for men or the left hands of women, but a "small" association between length of employment and the sensory latencies for the right hands of women was found. This association was statistically significant. The authors acknowledged that the disorder tends to be more prevalent among women in their right hand, but suggest that any such association between work and CTS appears to be a weak one - based on their findings.

### 2.3 Work Factors Versus Personal Factors

The mixed and confusing findings regarding cumulative trauma disorders have generated considerable controversy and debate. Two opposing groups have developed, with those who believe work factors are primary causal factors for CTDs in one camp, and those who believe that work factors cannot be primary causal factors for CTDs in the other camp. A few studies have produced results which place their authors firmly in the middle of this debate, such as Cannon et al. (1981) who found strong associations between CTS and vibratory hand-tool use among aircraft assembly workers, but also a strong association between CTS and gynecological surgery (i.e., hysterectomy and oophorectomy).

The debate perhaps reached its zenith when Norton Hadler attacked the findings of Armstrong et al. (1987) in an editorial published in the *Journal of Occupational Medicine* in 1990, calling the concept of cumulative trauma "iatrogenic", i.e, the result of diagnosis or treatment. Hadler questioned the data and analyses upon which the researchers had based their conclusion that CTDs are much more prevalent among workers in high-force, high-repetition job categories. He implied that the sample used may not be representative of industry in general because of plant and subject selection, and emphasized the finding that force category was not found to be related to CTDs for body areas other than the hand.

Silverstein and Fine answered Hadler's statements in an editorial in the *Journal of Occupational Medicine* in 1991, acknowledging that CTDs have multi-factorial causes, but stating that their sample was indeed representative. The authors could find no reason to believe that the seven selected plants were grossly unrepresentative of all plants that would have met the study criteria. They noted that force categories used in the study were based

solely on hand forces, so they had not been surprised at the finding of no association between hand force and non-hand CTDs. The authors asserted that there exists considerable support for the CTD concept within clinical reports and laboratory and epidemiological studies.

Stock (1991) examined all of the available evidence she could find regarding work-relatedness of CTDs of the neck and upper limbs, reviewing 49 relevant studies. Of these 49, only three met the a priori criteria she determined for inclusion in a meta-analysis. The rest were rejected due to design inadequacies, study type, inadequate metric of exposure, or other relevant criteria. The three selected studies included epidemiological findings of Silverstein et al. (1986, 1987), a study by Nathan (1988), and an earlier study by Luopajarvi et al. (1979) in Finland. All three studies were cross-sectional. Stock (1991) found that the Silverstein study (1986, 1987) was best, consistently outranking the other two in various individual quality of research criteria. The Nathan study (1988) was found to be poorest, with serious flaws in the measure of exposure, occupational hand use. All three studies found a statistically significant relationship between exposure and at least one of the relevant outcomes. The strongest associations were found by both Luopajarvi et al. (1979) and Silverstein et al. (1986, 1987) between ergonomic related exposures and hand and wrist tendon and tendon sheath disorders, including flexor and extensor tendinitis, tenosynovitis, DeQuervain's, and trigger finger.

Luopajarvi et al. (1979) also found a significantly increased prevalence of shoulder disorders among exposed workers, while the Silverstein study did not find a significant association between exposure and shoulder disorders in the highest exposure group (high-force, high-repetition) but did find a significant association between exposure and shoulder

disorders for workers in the high-force, low-repetition jobs. Recall however, that Silverstein et al. (1986, 1987) based their exposure categories on hand force, not on shoulder force, so this finding is not surprising.

Both Silverstein et al. (1986, 1987) and Nathan et al. (1988) found statistically significant increases in carpal tunnel syndrome in the highest exposure groups, with the Silverstein et al. data showing an odds ratio of 15.5, with a 95% confidence interval of 1.7 to 141.5. The Nathan et al. data (1988) show an odds ratio of 4.0, with a 95% confidence interval of 1.5 to 11.0. The authors of the Nathan study claim that their findings do not show a significant difference in bilateral slowing of nerve conduction among exposure groups with the statistical tests they used. Stock (1991) reanalyzed the Nathan et al. data (1988) and found statistically significant differences between exposure groups in spite of the authors' assertions. Stock reminds her readers that the Nathan methods for measuring exposure were seriously flawed, and that consequently the best estimates of the relationship of exposure to disease comes from the Silverstein data. Stock concluded that the available results "demonstrate a strong relationship between exposure and hand/wrist tendon disorders and carpal tunnel syndrome". Stock further concluded that "the strength of the associations between exposure and tendon disorders of the hand and wrist and carpal tunnel syndrome is quite high". The adjusted odds ratio that Silverstein et al. (1986, 1987) found was 31.7 for hand and wrist tendinitis, and 15.5 for carpal tunnel syndrome.

In October 1993 at the National Safety Council Congress in Chicago, Nathan presented updated findings of his research team. This time he admitted that work factors were found to be a risk for carpal tunnel syndrome, but stating that work was only a minor risk factor and

not as predictive as individual variables such as age or body mass index. In the same session, epidemiologist Thomas Hales of the National Institute of Occupational Safety and Health (NIOSH) answered Dr. Nathan's assertions by demonstrating that if Nathan's data are reanalyzed, a clear dose-response relationship is indeed found in with regard to carpal tunnel syndrome based on nerve conduction velocity testing. Hales points out that much of the variance in the Nathan data, up to 85%, was not explained by any factor, and may eventually be explained in other study scenarios by work factors.

## **2.4 Assessment of Occupational Factors**

A risk factor identified as "posture" might also be identified as "static exertion", and therefore be included with a general category of "force". Similarly, repeated "postures" or "exertions" might also be identified as "repetition". Such semantic distinctions often confuse the analysis and documentation of work-related CTD risk factors. Perhaps it is coincidences of these primary occupational factors which are more of interest than any effort to separate and analyze individually the various risk components. With this in mind, the following discussion examines the various work-related factors in greater detail.

### **2.4.1 Task Repetitiveness and CTDs**

Tichauer (1966) noted the repetitiveness of a ratchet screw driving task, at 5000 exertions per day, and associated this with stress on the forearm and hand in industry. Silverstein et al. (1987) strongly associated the coincidence of a high-force and high- repetition task category with incidence of carpal tunnel syndrome. Contributors to the manual Cumulative Trauma

Disorders, edited by Putz-Anderson (1988), cite several references as documentation of an association between cumulative trauma disorders and repetitive jobs or tasks.

One study, Smutz et al. (1992), examined the effect of low-force high-repetition manual activities on risks for carpal tunnel syndrome using animal and human cadaver tests, and concluded that tendinitis and tenosynovitis associated with low-force repetitive tasks is not the result of "cumulative strain" of the finger flexor tendons. The researchers suggest that a mechanism other than cumulative strain must be responsible for any tendon damage which occurs. One such possibility offered by the authors is that of mechanical wear and fraying or abrasion of the tendon. No indications of damage or wear were identifiable in the animal specimens after 729,000 task cycles over a period of three weeks. This finding adds weight to the notion that low force repetitive jobs (e.g., VDT data entry, small parts assembly) do not present significant risks over relatively short time periods, but may require weeks, months, or even years for tendon damage to develop and manifest.

Silverstein et al. (1987) identified a clear relationship between risks for hand/wrist CTDs and force-repetition combination categories. High-force/high-repetition jobs clearly offered the greatest risks for CTDs, suggesting that coincidence or combination of repetition and forceful exertion greatly increases risks for CTDs, at least for the hands and wrists.

#### **2.4.2 Working Posture and CTDs**

Less than desirable working postures were linked to increased lost time from work due to musculoskeletal illnesses by Westgaard and Aaras (1984) in an industrial study of manufacturing workers. For jobs requiring awkward postures, including trunk and shoulder



flexion and bent neck postures, the rate of sick leave due to musculoskeletal illnesses was correlated with length of employment and was significantly greater than sick leave rates in age-matched controls (general office workers). The researchers also found increasing lost time with increasing age. Turnover rates were high for strenuous jobs. As with any such epidemiological study, high turnover could introduce a "survivor" bias into the comparisons, thereby tending to underestimate the link between jobs factors and musculoskeletal illness. In spite of this possibility, the authors clearly identified a relationship between work factors - specifically, static awkward postures - and lost time from work due to musculoskeletal illness.

Results of follow-up studies published by Aaras and Westgaard et al. in 1986, 1987 and 1988 are summarized by the authors in a chapter of Sauter et al. (1990). These studies of female workers utilized actual worksites which were redesigned based on ergonomics principles. The series attempted to assess (a) whether or not the introduction of ergonomic interventions and principles reduces postural loads and (b) the extent to which reduced postural load influences the incidence of musculoskeletal illness. The researchers also examined the musculoskeletal injury incidence effects of postural loads when comparing different work tasks, and attempted to determine a safe level of work load. The group of jobs was light assembly work in a manufacturing environment. Generally, static postural loading of the shoulders, neck, and arms could be easily identified within most tasks prior to the ergonomic changes. Loads were estimated with EMG, while medical, epidemiological and work history data were carefully collected. Studies were conducted over a period of seven years for some jobs, four years for others, and up to eight years for still others.

The results, following ergonomic changes, include a considerable statistically

significant reduction in static trapezius load for some jobs, but no significant difference for others. There were no significant differences in shoulder flexion angles overall for one particular job when comparing old and new workstations. However, workers with high values of shoulder flexion in the original job recorded a considerable decrease in those angles at the ergonomically enhanced worksites.

Periods of sick leave due to musculoskeletal illnesses were significantly reduced in spite of a longer time of employment by the time the study was completed. The effect of ergonomic redesign was also assessed by comparing new employees, who worked only at the better workstations, with others in the group. These workers had a much higher probability of *not* taking sick leave due to musculoskeletal illnesses, a difference which was highly significant. Further, a clearly identifiable interruption in the increasing incidence of musculoskeletal sick leave was found to coincide with the ergonomic interventions.

The authors also confirmed that improvements were not due to any decrease in workload in terms of production demands. In fact, productivity on average was found to be higher in the period following the ergonomic improvements compared to the period prior to the workstation changes.

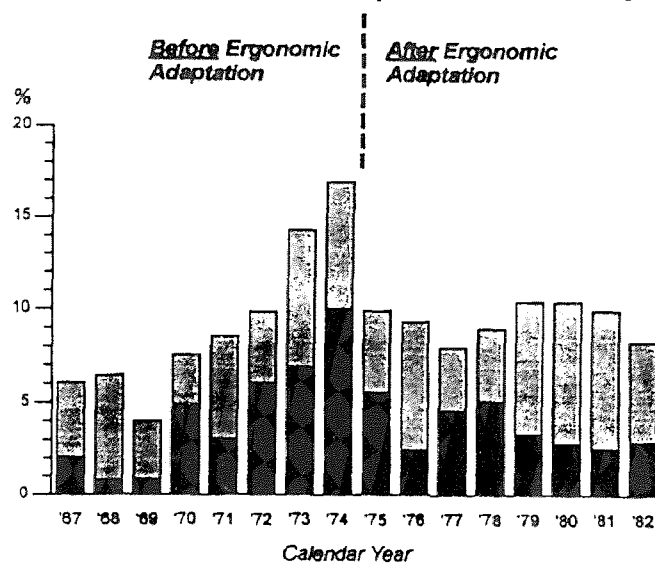
These researchers concluded that health effects of postural workload are influenced by (a) the magnitude of the postural angles (b) the distribution of muscle load between subgroups of muscles such as flexors and extensors, providing correspondingly reduced periods of activity for each group (c) the number and duration of very low postural angles,  $\pm 5^\circ$ , + for flexion or - for extension, and (d) the dynamic pattern of work. The general conclusion is that static muscle loading should be reduced to a minimum, and that dynamic

muscle activity, providing operators variation in posture and movements, is desirable.

A histogram provided by Westgaard et al. (1986) demonstrate that over the 15 year period, clear reductions in long-term sick leave following ergonomic enhancements occurred.

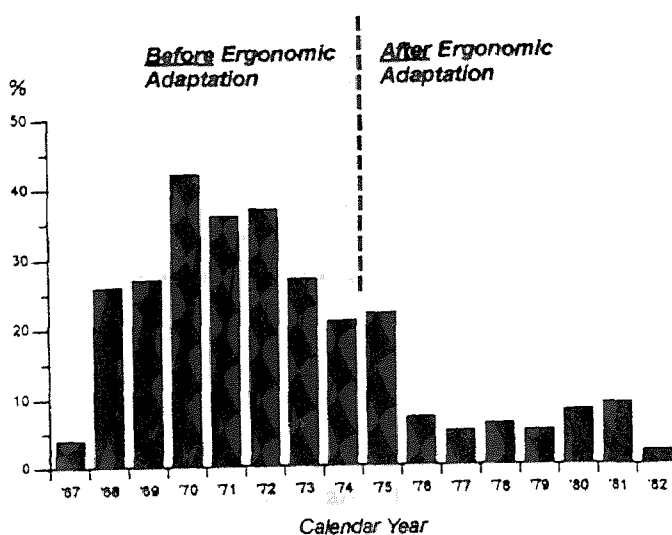
A separate graph illustrates significant reductions in labor turnover over the same period.

Note that the reductions coincided with the implementation of ergonomic changes.



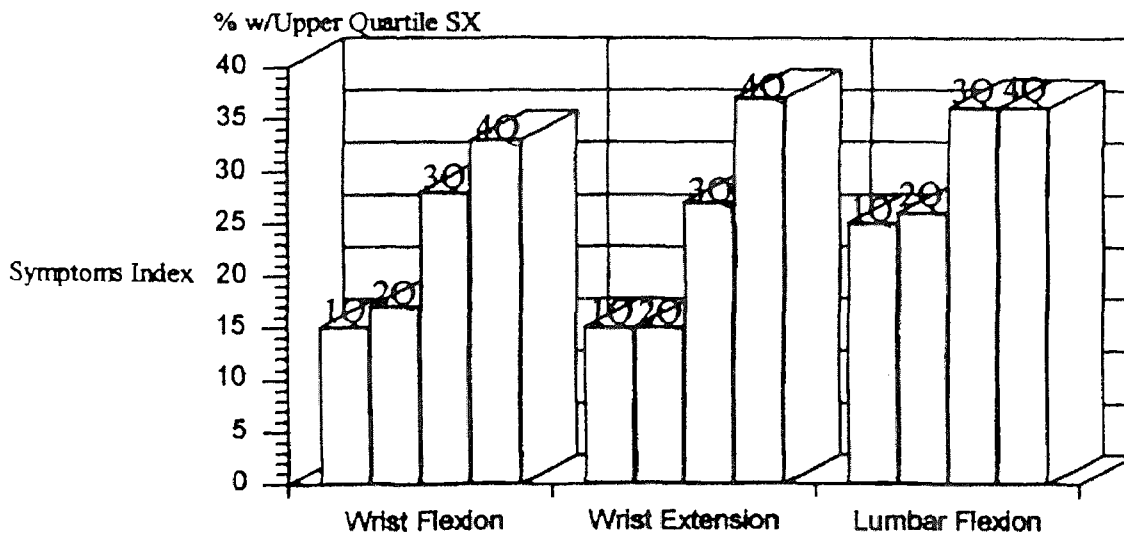
Westgaard et al. (1986)

**Figure 1** - Long term sick leave before/after ergonomic changes shown over a 16 year period



**Figure 2** - Labor turnover over the same 16 year period. A dramatic decrease in turnover occurred following ergonomic improvements.

More recently, Harber et al. (1993) documented evidence that posture per se is a significant variable in risk for upper extremity CTD, using a symptoms index among grocery checkers to identify increased risk. The researchers found that tasks which involve wrist flexion or wrist extension increased the proportion of workers in the highest quartiles of the symptoms index. This was also found to be true for trunk or lumbar flexion. The authors did not speculate as to why lumbar flexion increased symptoms in the upper extremities. In this study, specific motions were directly linked to specific symptoms independent of repetition, and indicates that postural loading, including static loading, is a risk factor for CTDs.



**Figure 3** - Motion and symptoms index are shown. The proportion of the population reporting in the upper quartiles of the symptoms index increases as motion increases, clearly showing the link between posture and symptoms (from Harber et al., 1993).

Prior to the documentation by Harber et al. linking postural variables to risks for CTDs, the field generally accepted that a relationship exists between hand and wrist postures and CTDs of the hand and wrist as summarized by Armstrong et al. (1982). Associations include those between carpal tunnel syndrome and repeated wrist flexion or extreme extension - particularly in combination with forceful pinching - repeated radial and ulnar deviations of the wrist associated with tenosynovitis or DeQuervain's disease, and exertions with a flexed wrist or ulnar deviation associated with tenosynovitis of the finger flexor tendons.

Tichauer and Gage (1977) point out some of the practical aspects of hand/wrist posture in relation to task activity, stating that holding and manipulating are mutually exclusive movements, and that when the wrist is flexed, the hand cannot grasp a rod firmly. The implication for task design is that the predominant action to be performed, holding or manipulation, should be determined and facilitated by appropriate ergonomic measures. Further, the coincidence of holding and manipulation demands should be avoided.

#### **2.4.3 Forceful Exertions and CTDs**

At the jobsite, forceful exertions and awkward postures frequently occur in combination. Consequently, the relative contributions of the two factors toward increased CTD risk are not easily defined or separated. A summary of occupational risk factors and hand/wrist CTDs by Armstrong et al. (1982) includes coincidences of force, posture, and repetition. Silverstein et al. (1987) perhaps offers the most distinct evidence of the contribution toward CTD risks made by forceful exertions since the study utilized high and low force-repetition combination categories.

Tichauer and Gage (1977) noted that force or thrust direction can interact with the probability of musculoskeletal illnesses. For example, a movement demanding strong pull and simultaneous counterclockwise rotation of the right hand should be avoided, since such a movement is mutually incompatible for the biceps. This is due to the fact that the biceps is both a flexor of the forearm and an outward rotator of the wrist. Perhaps both force magnitude and direction are important factors in determining the probability of a CTD.

#### **2.4.4 Mechanical Stresses and CTDs**

Tichauer and Gage (1977) provide ample discussion of the role of contact stresses in CTD development, along with some important implications for ergonomic hand-tool design. Assumptions that mechanical stress or deformation of the tissue contribute substantially to ischemia and peripheral median nerve compression were tested and confirmed by Szabo and Gelberman (1987). The results showed a rapid decline in sensory amplitude action potentials and an increase in sensory latency when direct pressure is applied to the palmar aspect of the wrist over the carpal tunnel. The implications for risk of carpal tunnel syndrome are clear. Contact stresses to other body areas or tissues are also known to contribute to CTDs, including effects of hard or sharp edged tools on the fingers in the development of stenosing tenosynovitis crepitans, or "trigger finger" (Putz-Anderson, 1988).

#### **2.4.5 Temperature and CTDs**

Cooler temperatures increase the probability of CTDs to the upper limbs, probably due to decreased bloodflow to the extremities, and can accentuate possible neurological symptoms.

There is some evidence (Georgitis, 1978) that extreme cooling may directly produce tendinitis.

#### **2.4.6 Vibration Exposure and CTDs**

Cannon et al. (1981) associated hand-tool vibration with CTDs, including impact tools, power tools, buffers and grinders, and others. Wasserman et al. (1991) examined hand-arm vibration syndrome among miners exposed to jackleg-type drills over a period of time. The researchers found that the median latency to symptoms of tingling, numbness, and blanching was 4.5 years. Radwin et al. (1987) found that vibration influences the manner in which workers hold and use their handtools. Distinguishing the effects of vibration on workers using vibratory handtools or grasping vibrating parts from effects of forceful or repeated exertions is difficult.

### **2.5 Assessment of Individual Factors**

#### **2.5.1 Anthropometric Dimensions and CTDs**

Several studies have examined the possibility that wrist dimensions have an influence on predisposition for carpal tunnel syndrome. Gordon et al. (1988) found that 24% of subjects with wrist ratios (division of the anteroposterior wrist dimension by the mediolateral dimension) of less than 0.70 had abnormal electrodiagnostic studies compared to 74% of subjects with wrist ratios greater than or equal to 0.70. The authors suggest that wrist ratio determination could be useful in job placement efforts. However, Bleeker (1987) examined the carpal canal size with computerized tomography and found that wrist circumference was

not a reliable predictor of the smallest carpal canal area. The researcher could find no anthropometric measurements that could be used to determine carpal canal size. However, Bleeker's findings did suggest that a subgroup of the general population may contain a risk factor, a small carpal canal, which is associated with development of CTS in the workplace when their hands are exposed to the appropriate ergonomic stresses.

Fernandez et al. (1989) examined several factors, including wrist anthropometry, and attempted to correlate these with incidence of CTS but were unable to do so, finding no significant correlations with anthropometric dimensions of the wrist. The researchers did find significant differences in strength, range of motion, and task performance criteria.

Interestingly, those who have encountered negative findings regarding correlation of carpal tunnel syndrome and wrist dimensions have examined individual wrist dimensions, not the ratio of two wrist dimensions. Nathan et al. (1992) found that wrist depth/width ratio explained 13% of the of the variance in a longitudinal study of the etiology of carpal tunnel syndrome, a significant but marginal finding.

Studies to date of anthropometric dimensions as predictors of CTDs have almost exclusively focused on carpal tunnel syndrome, and ignored a host of other common CTDs. There is at least one possible exception.

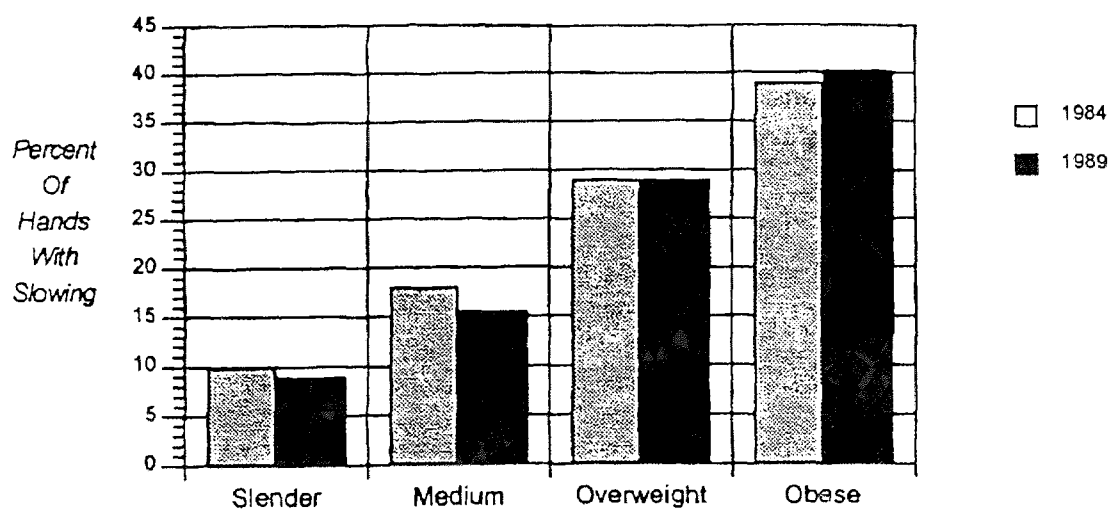
Australian researchers (Green and Briggs, 1989) examined several non-wrist anthropometric dimensions in a cross sectional study and found that hip width and seat breadth correlated with "overuse" injuries, while other dimensions, such as stature, thigh clearance, and resting elbow height, did not correlate with overuse injuries. Unfortunately, the researchers did not specify their method of defining an "overuse" injury except to note



that those designated as "sufferers" experienced, within one week prior to the study, symptoms previously associated with overuse injury.

### 2.5.2 Body Mass And CTDs

Nathan et al. (1992) found that body mass index (BMI) defined as weight/height, explained 53.7% of the variance in a stepwise regression analysis of maximum sensory nerve conduction latency of the median nerve. The BMI explained a greater proportion of the variance than any other factor. Green and Briggs (1989) found that a greater proportion of female individuals who were overweight were affected by CTDs compared to those not overweight. Tsai et al. (1992) found that persons who are overweight are more likely to be affected by both low-back and non low-back musculoskeletal disorders.



**Figure 4** - Body-mass index and electrodiagnostic indications of CTDs. The proportion of population with slowing determined through sensory nerve conduction velocity testing is shown (Nathan et al. 1992).

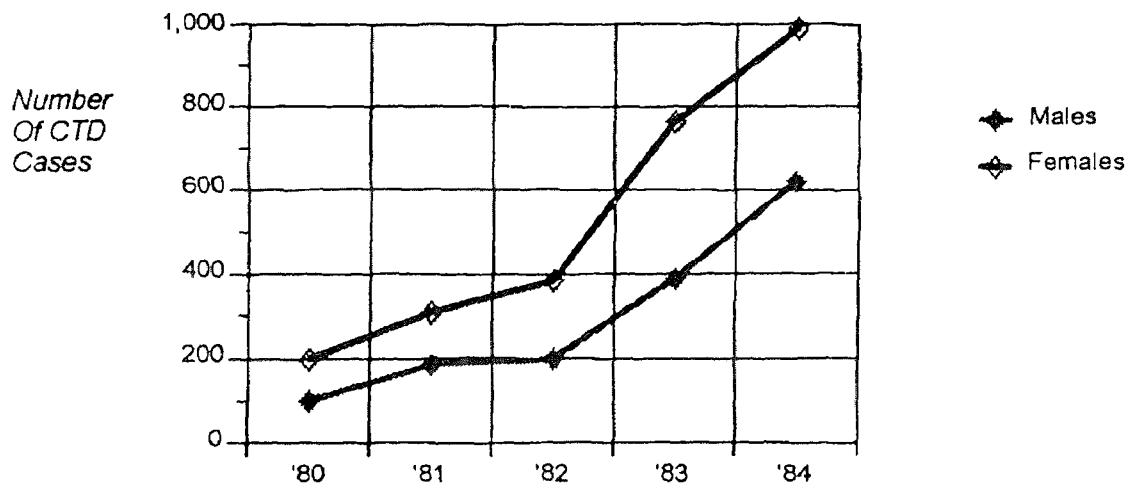
### 2.5.3 Gender and CTDs

Analysis of worker's compensation claims in Canada revealed that female machining and fabricating workers experience nine times the number of cumulative trauma claims and eleven times the number of lost days from work than the average worker in Ontario (Krammer, 1992). Males in the same occupations, however, had only twice the Ontario rates of CTDs, indicating a strong gender effect on claims. While a similar relative difference was discovered among clerical workers, the CTD rate for clerical occupations was below the average for all occupations. Therefore, a job or occupation effect was also discovered. The author points out that the findings may be due to inherent differences between males and females, to females being more often placed in highly repetitive jobs, or to some combination of these.

Green and Briggs (1989) found significant interaction between CTD prevalence and anthropometric dimensions only among females. Among males, no significant interaction of body dimensions and CTD prevalence was found.

In a large cross-sectional study, Tsai et al. (1992) found that women were more likely to experience both low-back and non low-back occupationally related disorders compared to men, but the differences were not statistically significant.

In a large workers compensation claims study, Tanaka et al. (1988) found the overall CTD case rate per 10,000 workers was 4.1 for females, and 2.3 for males. Armstrong et al. (1987b) reports that the increased risk associated with gender differences is substantially less than the increased risk associated with job characteristics.



**Figure 5** - Gender and CTDs. Females tend to be more affected compared to males (Tanaka et al., 1988).

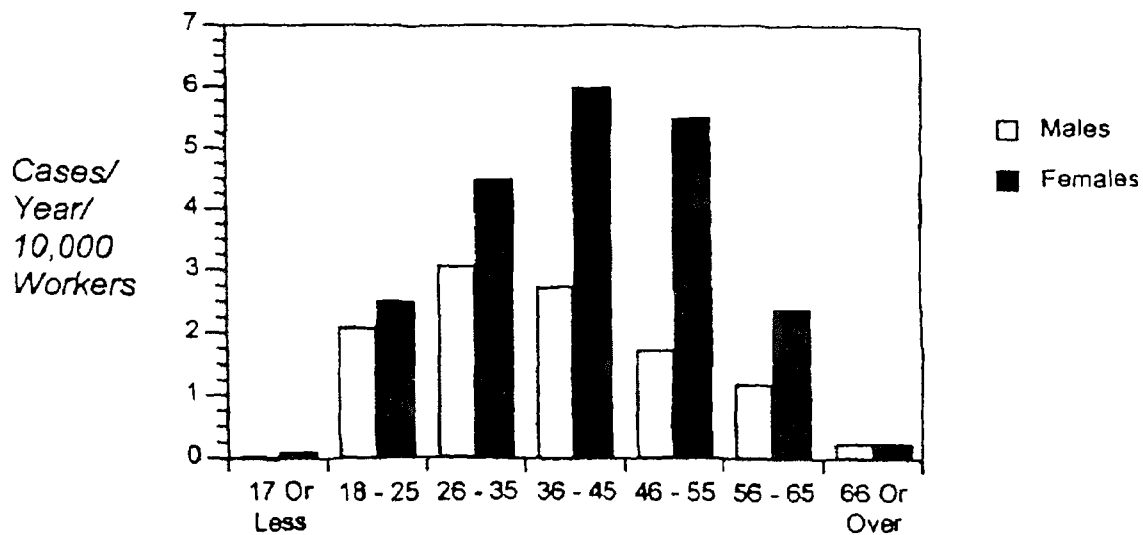
#### 2.5.4 Smoking and CTDs

A large cross-sectional study of more than 10,000 workers at Shell Oil company manufacturing facilities (Tsai et al., 1992) found that a significantly greater proportion of smokers versus non-smokers are affected by both low-back and non low-back musculoskeletal disorders. The researchers also found that overweight persons were significantly more likely to be affected by such disorders.

#### 2.5.5 Age and CTDs

Westgaard and Aaras (1984) documented a connection between increasing age and increasing lost time from work due to musculoskeletal illnesses. The researchers also found that

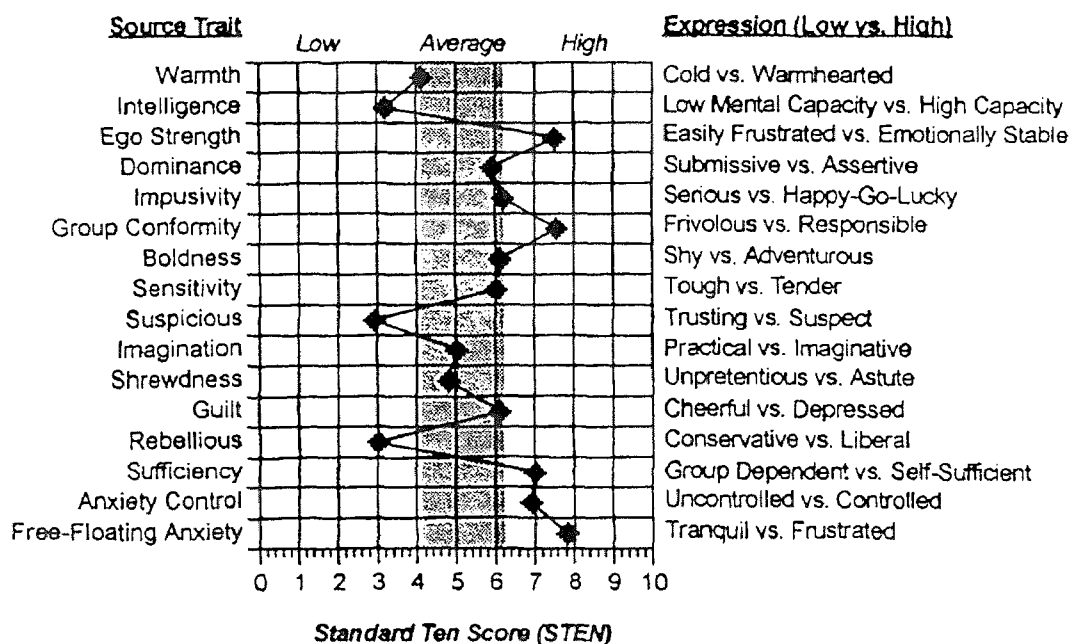
musculoskeletal illness increased with increasing length of employment. Nathan et al. (1992) found age to be correlated with slowing of sensory conduction of the median nerve, a possible indicator of propensity for carpal tunnel syndrome. Tanaka et al. (1988) reported the case rate for upper body CTDs is highest for women aged 36-45 years old, and for men at ages 26-35, based on a large workers compensation claims study. These data suggest that age does influence susceptibility for CTDs, but that the relationship is not linear, but modal.



**Figure 6 - Age and CTDs.** A bimodal relationship was found by Tanaka et al. (1988).

### 2.5.6 Psychological Factors and CTDs

One group of researchers, Fernandez et al. (1989), examined personality traits of individuals diagnosed with carpal tunnel syndrome citing the Sixteen Personality Factor Questionnaire or 16PF by Cattell, Eber, and Tatsuoka. The researchers determined that one personality factor seems to be associated with CTS: high scores on a continuum scale to measure "free-floating anxiety". Anchor points on this scale, low to high, are "tranquil" versus "frustrated", respectively. The authors, citing a summary of numerous sources, point out that high scores of free-floating anxiety have been consistently related to high frequencies of general physical illness, specifically including rheumatoid arthritis, hypertension, diabetes, and asthma, among others.



**Figure 7** - Psychological factors and CTDs. At the bottom of the list, high levels of "free-floating anxiety" is characteristic of person with CTDs. Note that persons with CTDs were also found to possess below average intelligence.

Kiesler and Finholt (1988) reviewed the epidemic of repetitive strain injury (RSI) in Australia and concluded that the fundamental difficulty is dissatisfaction with the workplace. The authors do not suggest that RSI is an iatrogenic phenomenon - a means to promote the practice of medicine - or that RSI is a method used by malingerers to defraud their employers. The authors instead conclude that workers legitimately have symptoms of RSI, but if the work environment were better and jobs more satisfying, RSI symptoms would be less important.

This evidence suggests that intervention efforts which focus strictly on the physical aspects of worksites may be inadequate to curtail workers compensation claims for CTDs, and that job enlargements, improved work environments, better management of new technology in the workplace, and opportunities for advancement are also important opportunities for improvements which can be combined with physical worksite enhancements.

### **2.5.7 Exercise and CTDs**

Three separate studies have examined the effects of formalized exercise programs on propensity for CTDs. Two focused on carpal tunnel syndrome (Williams et al., 1989; Thomas et al., 1993) while one examined musculoskeletal symptoms in a more general sense (Silverstein et al., 1988). All reached similar conclusions: exercise does not appear to reduce the likelihood of CTDs. Silverstein et al. based their findings on subjective postural discomfort surveys taken before and after a year long program of exercise in the workplace. The researchers found no change in the proportion of subjects with symptoms better, the same, or worse after the one year period. Williams et al. used grip strength, Phalen's test

results, and liquid crystal thermography to test for changes in propensity for carpal tunnel syndrome. The results indicated small, non-significant benefits of exercise. These researchers used engineering economic analysis to estimate the payback period on investment into exercise programs at eleven years, casting doubt on the economic efficacy of such programs. Thomas et al. utilized motor nerve conduction latencies through the carpal tunnel to measure likelihood of CTS, but found no differences between the exercise and no-exercise group. A significant increase in grip strength however was noted among the exercise group.

Hebert (1992) provides a few anecdotal reports of exercise programs which appear to have helped to decrease losses. However, the author provides little detail about these anecdotes and makes no mention of use of controls for comparison. Hebert cites a published 63% reduction in losses in one department at an Ethicon, Inc. site following the introduction of an exercise program.

However, upon close inspection of the Ethicon material (Lutz et al., 1987) one finds that the reduction in losses occurred in one department over only a three month period, and was introduced in the context of a larger ergonomics program that included job design changes, medical management, and employee education and training. No controls for comparison were apparently utilized. Given the relatively short period (three months) the reduction in losses could be merely random fluctuations in injuries or injury reporting, a temporary Hawthorne effect, a fluctuation in productivity demands, or any one of dozens of other possible variables. As a seller of consulting services to industry on development of exercise programs, Hebert's assertions appear to be nothing more than marketing "hype" in the guise of scientific evidence.

Thompson (1990) found marginal benefits to productivity resulting from an exercise break program introduced to workers in a VDT work environment. However, the study occurred over only four months before a new incentive pay program was put into effect, confounding any subsequent results. The study utilized no controls for comparison, and the limited time frame (four months) over which any results were obtainable indicates a strong possibility of Hawthorne or other transient effects.

In summary, exercise programs do not appear to offer significant long term help toward reducing CTDs. While there may be psychological benefits to workers associated with exercise programs, no convincing evidence of this is currently available.

### **2.5.8 Other Individual Factors**

Acute trauma, pregnancy, endocrinological disorders, vitamin B6 deficiency, rheumatoid arthritis, gynecological surgery, oral contraceptives, and alcohol use have all been associated with increased risks for CTDs. Armstrong (1990) summarized indications of such personal factors in an engineering course training manual.

While strong evidence supports the contribution of personal factors in some situations, work factors clearly play the major role in many other situations.

### **2.5.9 The Disorders - Descriptions and Associated Activities**

Cumulative trauma disorders, a collective of slow onset tendon, nerve, and neurovascular disorders of the upper or lower extremities, are summarized on the following table with associated work activities, as presented by Kroemer (1992).



TABLE I. (continued)

<i>Disorder Name<sup>A</sup></i>	<i>Description</i>	<i>Typical Job Activities</i>
Tendonitis (tendinitis) (T)	An inflammation of a tendon. Often associated with repeated tension, motion, bending, being in contact with a hard surface, vibration. The tendon becomes thickened, bumpy, and irregular in its surface. Tendon fibers may be frayed or torn apart. In tendons without sheaths, such as within the elbow and shoulder, the injured area may calcify.	punch press operations, assembly work, wiring, packaging, core making, use of pliers
Tendosynovitis (tenosynovitis, tendovaginitis) (T)	This disorder occurs to tendons that are inside synovial sheaths. The sheath swells. Consequently, movement of the tendon within the sheath is impeded and painful. The tendon surfaces can become irritated, rough, and bumpy. If the inflamed sheath presses progressively onto the tendon, the condition is called stenosing tendosynovitis. deQuervain's syndrome is a special case occurring in the thumb; the trigger finger condition occurs in flexors of the fingers.	buffing, grinding, polishing, sanding, punch press operation, sawing, cutting, surgery, butchering, use of pliers, "turning" control such as on a motorcycle, inserting screws in holes, forceful hand wrenching
Thoracic outlet syndrome (neurovascular compression syndrome, cervicobrachial disorder, brachial plexus neuritis, costoclavicular syndrome, hyperabduction syndrome) (V,N)	A disorder resulting from compression of nerves and blood vessels between clavicle and first and second ribs, at the brachial plexus. If this neurovascular bundle is compressed by the pectoralis minor muscle, blood flow to and from the arm is reduced. This ischemic condition makes the arm numb and limits muscular activities.	buffing, grinding, polishing, sanding, overhead assembly, overhead welding, overhead painting, overhead auto repair, typing, keying, cashiering, wiring, playing musical instruments, surgery, truck driving, stacking, material handling, postal letter carrying, carrying heavy loads with extended arms
Trigger finger or thumb (T)	A special case of tendosynovitis where the tendon becomes nearly locked, so that its forced movement is not smooth but in a snapping, jerking manner. This is a special case of stenosing tendosynovitis crepitans, a condition usually found with digit flexors at the A 1 ligament.	operating finger trigger, using hand tools that have sharp edges pressing into the tissue or whose handles are too far apart for the user's hand so that the end segments of the fingers are flexed while the middle segments are straight
Ulnar nerve entrapment (Guyon tunnel syndrome) (N)	Results from the entrapment of the ulnar nerve as it passes through the Guyon tunnel in the wrist. It can occur from prolonged flexion and extension of the wrist and repeated pressure on the hypothenar eminence of the palm.	playing musical instruments, carpentering, bricklaying, use of pliers, soldering, hammering
White finger (“dead finger,” Raynaud's syndrome, vibrations syndrome) (V)	Stems from insufficient blood supply bringing about noticeable blanching, (finger turns cold, numb, and tingles); sensation and control of finger movement may be lost. The condition is due to closure of the digit's arteries caused by vasospasms triggered by vibrations. A common cause is continued forceful gripping of vibrating tools, particularly in a cold environment.	chain sawing, jack hammering, use of vibrating tool, sanding, paint scraping, using tool too small for the hand, often in a cold environment
Ulnar artery aneurysm	Weakening of a section of the wall of the ulnar artery as it passes through the Guyon tunnel in the wrist; often from pounding or pushing with heel of the hand. The resulting “bubble” presses on the ulnar nerve in the Guyon tunnel.	assembly work

<sup>A</sup>N = nerve; T = tendon; M = muscle; V = vessel disorders.

**TABLE I. Common Repetitive Strain Injuries, Primarily to Nerves (N), Tendons and Tendon Sheaths (T), Muscles (M), or Blood Vessels (V)**

Disorder Name <sup>A</sup>	Description	Typical Job Activities
Carpal tunnel syndrome (writer's cramp, neuritis, median neuritis) (N)	The result of compression of the median nerve in the carpal tunnel of the wrist. This tunnel is an opening under the carpal ligament on the palmar side of the carpal bones. Through this tunnel pass the median nerve, the finger flexor tendons, and blood vessels. Swelling of the tendon sheaths reduces the size of the opening of the tunnel and pinches the median nerve and possibly blood vessels. The tunnel opening is also reduced if the wrist is flexed or extended, or ulnarly or radially pivoted.	buffing, grinding, polishing, sanding, assembly work, typing, keying, cashieng, playing musical instruments, surgery, packing, housekeeping, cooking, butchering, hand washing, scrubbing, hammering
Cubital tunnel syndrome (N)	Compression of the ulnar nerve below the notch of the elbow. Tingling, numbness, or pain radiating into ring or little fingers.	resting forearm near elbow on a hard surface and/or sharp edge, also when reaching over obstruction
deQuervain's syndrome (or disease) (T)	A special case of tendosynovitis that occurs in the abductor and extensor tendons of the thumb where they share a common sheath. This condition often results from combined forceful gripping and hand twisting, like in wringing cloths.	buffing, grinding, polishing, sanding, pushing, pressing, sawing, cutting, surgery, butchering, use of pliers, "turning" control such as on a motorcycle, inserting screws in holes, forceful hand wringing
Epicondylitis ("tennis elbow") (T)	Tendons attaching to the epicondyle (the lateral protrusion at the distal end of the humerus bone) become irritated. This condition is often the result of impacting or jerky throwing motions, repeated supination and pronation of the forearm, and forceful wrist extension movements. The condition is well known among tennis players, pitchers, bowlers, and people hammering. A similar irritation of the tendon attachments on the inside of the elbow is called medical epicondylitis, also known as "golfer's elbow."	turning screws, small parts assembly, hammering, meat cutting, playing musical instruments, playing tennis, pitching, bowling
Ganglion (T)	A tendon sheath swelling that is filled with synovial fluid, or a cystic tumor at the tendon sheath, or a joint membrane. The affected area swells up and causes a bump under the skin, often on the dorsal or radial side of the wrist. (Because it was in the past occasionally smashed by striking with a Bible or heavy book, it was also called a "Bible Bump.")	buffing, grinding, polishing, sanding, pushing, pressing, sawing, cutting, playing musical instruments, playing tennis, pitching, bowling
Neck tension syndrome (M)	An irritation of the levator scapulae and trapezius group of muscles of the neck, commonly occurring after repeated or sustained overhead work.	belt conveyor assembly, typing, keying, small parts assembly, packing, load carrying in hand or on shoulder
Pronator (teres) syndrome (N)	Result of compression of the median nerve in the distal third of the forearm, often where it passes through the two heads of the pronator teres muscle in the forearm, common with strenuous flexion of elbow and wrist.	soldering, buffing, grinding, polishing, sanding
Shoulder tendinitis (rotator cuff syndrome or tendinitis, supraspinatus tendinitis, subacromial bursitis, subacromial bursitis, partial tear of the rotator cuff) (T)	This is a shoulder disorder at the rotator cuff. The cuff consists of four tendons that fuse over the shoulder joint where they pronate and supinate the arm and help to abduct it. The rotator cuff tendons must pass through a small bony passage between the humerus and the acromion, with a bursa as cushion.	soldering, buffing, grinding, polishing, sanding

## CHAPTER 3

### RESEARCH OBJECTIVES

As evidenced by the previous overview of current literature regarding CTDs, a variety of work and individual factors enter into the causation of such disorders. The degree to which each of these factors can be controlled, and by what means, is quite important. Jobsite ergonomic variables can be controlled more readily than personal or individual factors. Therefore, the objective of this study is to test and confirm if ergonomic improvements reduce the probability of CTDs. Since there exists no known direct measures for CTD risk, secondary measures are utilized to assess CTD risk. The selected secondary measures are muscle electrical activity which reflects the force of exertions over time measured by electromyograph (EMG), and postural angles or position ranges over time estimated by work sampling.

In order to prescribe and verify appropriate ergonomic measures for a specific job, standard ergonomic principles are applied in retrofitting an existing workstation. A workstation at an electronics assembly/manufacturing company, which contains similarities to many other related workstations at the same company, has been selected with the intention of extrapolating its results to the other workstations. Task requirements for the selected job include: small parts assembly, insertion of the assembly into a press machine, activation of controls, setting aside the part, and repeating the entire process. To summarize, the research objectives of the study are:

- 1) To prescribe ergonomic measures and verify that ergonomic workstation improvements significantly reduce secondary measures of cumulative trauma disorder risk, and therefore, presumably, the risks for CTDs. Alternatively, to confirm that such improvements do not significantly reduce any secondary measures of risk, and are therefore not justified economically.
- 2) To formulate results, if positive, in such a way as to allow generalization and extrapolation of findings to an entire family of essentially similar jobs. This can be done by clearly stating the general design principles being tested.
- 3) To confirm that secondary measures have in fact accurately reflected risks for CTDs by utilizing incidence or epidemiological data as these become available.

The press operation and assembly task first involves placing several individual parts together in the proper configuration in the press fixture. The parts include one small spring, one hard plastic base with breaker subassembly, and one plastic button. Then the press is activated to compress the parts together, with proper tolerances and alignment, into a single unit. The result is a circuit breaker and switch which can be reset by pressing the button after being "tripped" by specified electrical conditions. These reset breakers are used in a variety of systems including both military and civilian aircraft, and many motor control applications.

## CHAPTER 4

### MATERIALS AND EXPERIMENTAL METHODS

#### 4.1 Variables

The experiment was originally to be conducted in three phases: (a) the pilot or test run, (b) baseline data collection, and (c) follow-up data collection for the enhanced or improved workstation. Due to practical considerations, however, it was easier to build a completely new workstation rather than retrofit the old workstation. This provided an opportunity to greatly reduce experimental error that would have resulted from an attempt to locate and relocate EMG surface electrode positions based on anthropometric landmarks and photographs. Instead, the two workstations (old and new) were positioned within a few feet of each other, with each fully functional. EMG data were gathered in a single setting for each subject without removal of the electrodes.

Independent variables included the machine fixture height and location, the type and location of the press controls, and the angle and layout of parts trays and work-table.

Dependent variables include electromyograph signal integrated over a part cycle time for each of three selected muscle groups, and postural angles classified into ranges or intervals through work sampling methods.

The EMG and postural experiments were conducted independently, with no attempt to correlate the two variables. Fixed variables include the workstation arrangement for original and enhanced workstation conditions, chair type and height, and cycle time per workstation-subject combination for EMG signal integration.

## 4.2 Subjects

Twelve subjects were originally selected from the motor controls department CC116 or an adjacent department and participated in the pilot aspect of the study. During what was to have been the baseline aspect of the study, the same twelve subjects participated. After the old and new workstations were prepared, the experiment was actually conducted on ten of the original twelve subjects. One half of the data for subject number 3 was inadvertently corrupted or lost, so subject 3 was excluded from the analysis, leaving the number of subjects actually utilized for the EMG analysis at nine. All nine subjects were female, reflecting the overwhelming majority of workers actually doing this job. Ages ranged from early twenties to the late fifties. Seniority levels varied widely. All operators had previous experience with the press operation job, while most were also experienced in similar jobs in the same department. None of the subjects have been exclusively dedicated to this one press operation job; all subjects work a variety of jobs within the department, an arrangement that is characteristic of this department.

For the postural analysis, data were collected on four of the original 12 subjects.

## 4.3 Force Measurement - Electromyography

Surface EMG's were measured and recorded using a computer-based EMG monitoring system. The data were read and stored in a personal computer for later retrieval and analysis. Signals were filtered through a narrow bandpass filter ranging from 100 to 200 HZ, with 0.25 microvolts input noise, and basic accuracy of plus or minus 3%.

Signals were integrated over a fixed time period which was set for each operator-workstation combination based on the mean cycle time per part as estimated during what

appeared to be a near steady state condition. Here, "cycle time" is defined as the time to complete one part. A review of cycle time data from the pilot and baseline data revealed that the data tend to be distributed in lognormal fashion. A best-fit curve was determined via use of the SIMAN Output Processor. The Output Processor is generally used to find best-fit curves for input data to be utilized in a simulation model. The best-fit function reveals which distributions are most appropriate for creating a realistic simulation. Standard statistical test for goodness-of-fit are utilized. Since the data distribution was nearly symmetrical except that the right tail was longer in lognormal fashion, mean cycle time was chosen for the EMG period in order to eliminate or reduce a possible source of variability by truncating each reading at the mean.

Pilot and baseline aspects of the study revealed substantial within-subject variation for the EMG data based on a sample size of ten cycles per subject during the pilot, and for twenty cycles per subject for the baseline. Consequently, during the actual experiment, sample size was increased to the extent practical with no attempt to balance the design of experiment. Generally, 40 to 60 data points, EMG signals integrated over a cycle, were collected for each subject-workstation condition. Sample size varied based on the availability of parts and the number of good readings available from those taken. If an operator paused to speak to a supervisor or co-worker, that reading was scrapped. Similarly, if an operator dropped a part, ran out of parts, or performed any unanticipated tasks such as reaching for a new parts tray, those readings were scrapped.

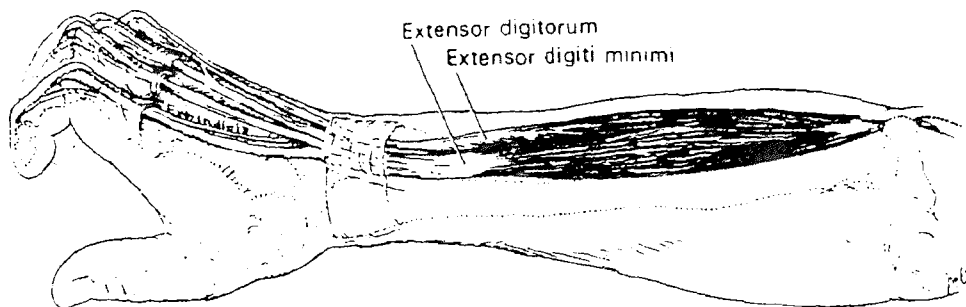
	subj 1	subj 2	subj 4	subj 5	subj 6	subj 7	subj 8	subj 9	subj 10
work-station I (old)	data n=53	data n=57	data n=54	data n=40	data n=44	data n=53	data n=48	data n=54	data n=52
work-station II (new)	data n=56	data n=60	data n=50	data n=53	data n=41	data n=54	data n=54	data n=40	data n=72

**Table 2** Sample sizes for subject and condition for the unbalanced design of experiment

#### 4.4 Muscle Groups

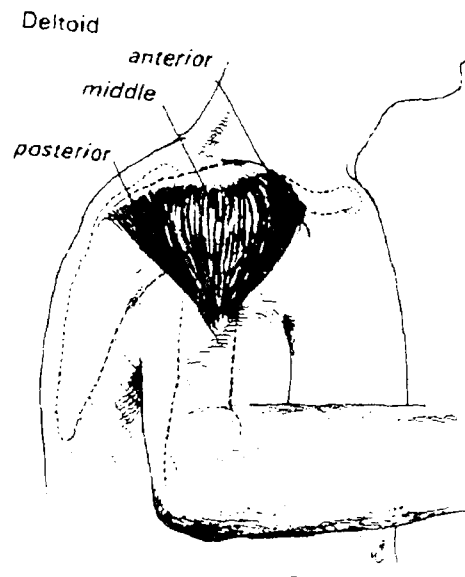
Three distinct muscle groups were selected for measurement: (a) extensor digitorum and extensor digiti minimi to represent the activity of the hand/wrist (b) anterior deltoid to represent the activity of the shoulder, and (c) upper trapezius to represent the activity of the head and neck.

The job entails dynamic and static flexion and extension of the wrist. A convenient muscle group located near the surface, that of wrist extensors, was selected to represent wrist activity and to provide for clear EMG readings.

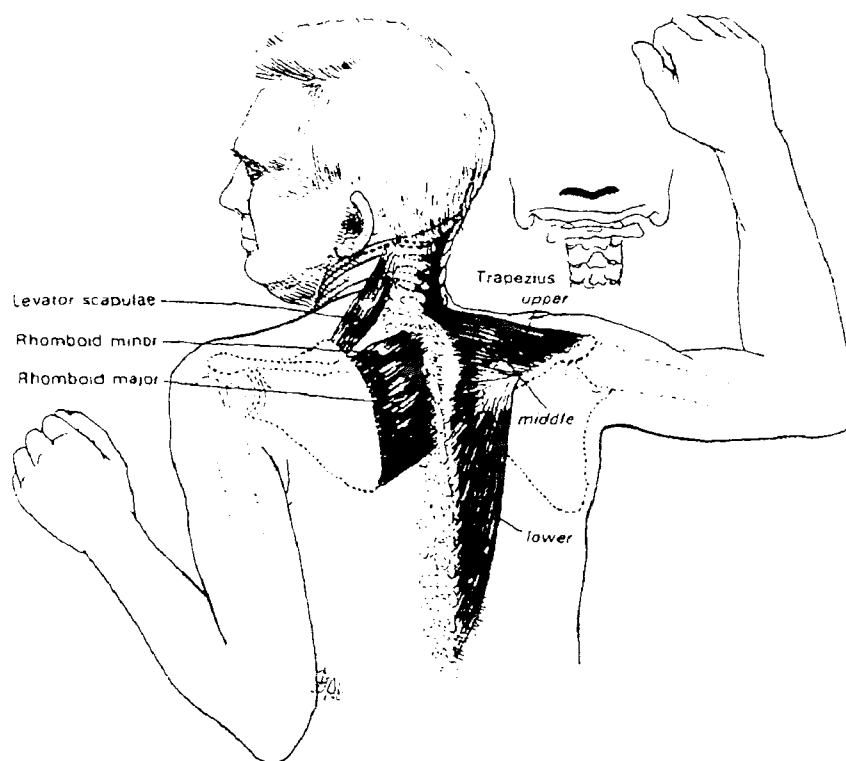


**Figure 8** - Extensor digitorum, muscle group to represent hand/wrist muscle activity (from Kendall and McCreary, 1983)





**Figure 9** - For the shoulders, the anterior deltoid was selected since this muscle is the primary shoulder flexor (from Kendall and McCreary, 1983)



**Figure 10** - For the head and neck, the upper trapezius was selected since the levator scapulae is generally too small to provide for accurate electrode placement and reliable readings (from Kendall and McCreary, 1983).

#### **4.5 Electrode Placement**

Basmajian and DeLuca (1985) recommend that the best location of an electrode is in the region halfway between the center of the innervation zone and further tendon of a chosen muscle or muscle group. The authors further recommend a standard interdetection surface spacing of one centimeter between electrodes. These recommendations were followed to the extent practical. Since electrodes were not removed from one workstation condition to the next, exact electrode placement was not crucial other than general positioning to reflect the muscle activity of interest.

#### **4.6 Variability**

In Sauter et al. (1990) Aaras et al. conclude that EMG data on static trapezius loads of female industrial workers have great variation within groups or between subjects. The pilot study here found that signal variation for all three muscle groups was large. For the hand/wrist and shoulder muscle groups, data were collected for dynamic tasks which also contained static elements, such as when the wand controls were activated by displacing them and holding the position for one to two seconds. For the neck or upper trapezius muscle, activity was largely static, similar to that noted by Aaras et al., indicating that any attempt to pool the data would likely yield very unreliable results unless some normalizing technique were applied. Consequently, a within-subjects design was indicated, with no expectation of interaction between subjects. In essence, each subject acted as her own control.

### 4.7 Pilot Results

During the pilot, a subject was tested in two different sessions using a sample of size ten each, in close proximity of time, with the same workstation conditions, and without removing the electrodes between sessions. The following data resulted:

#### TESTING OF VARIANCES

	critical value $t_{(.05)}$		$F_{(9,9)} = 3.18$	Subject #5
	SESSION 1	SESSION 2		
ch. 1	16.3 (2.62)	15.1 (1.12)	$F(\text{ch.1}) = 5.47$	**signif.
ch. 2	8.4 (2.31)	8.9 (1.4)	$F(\text{ch.2}) = 2.72$	
ch. 3	3.3 (.30)	3.0 (.18)	$F(\text{ch.3}) = 2.77$	

#### TESTING OF MEANS

	critical value $t_{(.05)}$	$t_{(.05)} = 1.75$	$df = 16.3$
$t(\text{ch.1}) = 1.33$			not significant
$t(\text{ch.2}) = .585$			not significant
$t(\text{ch.3}) = 2.71$			**significant

Since a significantly different mean value was found for one of the three muscle groups (upper trapezius) based on a sample size of ten cycles in each of two sessions with identical conditions, it was suspected that average neck muscle activity changed over short

Missing Page

#### **4.8 Data Smoothing**

Since the graphed data clearly demonstrate wide variation for two of the three muscle groups, the possibility of background noise in the readings was considered. Also, a phenomenon often called "crosstalk", was considered. This effect is similar to background noise which may be inherent to muscle electrical activity when measured by EMG.

Crosstalk results from electrical activity from adjacent muscle groups which are not being studied. To compensate for this phenomenon, data smoothing techniques were applied to the raw EMG data. Two different smoothing methods were utilized. First, a simple moving window average method was applied. The window size to the right and to the left of a data point was set at two. The second technique, called the "Savitzsky-Golay" filter or "least-squares" filter consists of fitting a least squares fourth degree polynomial through the data point and several points on either side. The window size was set at three for each side since upon graphing the data, this window size appeared to provide a distribution that generally looked normal. Details regarding the Savitzsky-Golay method are provided elsewhere (Press et al., 1992). Example graphs of the raw, smoothed, and Savitzsky-Golay filtered data for each subject, muscle group and condition are shown in the Appendix.

#### **4.9 Design of Experiment - EMG**

While the data for each muscle group were recorded simultaneously, three separate analysis of variance (ANOVA) tests were conducted, one for each muscle group. The main effects in the model were the workstation effect, the subject effect, and the workstation-subject interaction effects. Although a subject effect was calculated, this was

of little interest here since significant differences from subject to subject due to the known individualistic nature of muscle activity and EMG readings were fully expected. The main interest here was the workstation effect and any subject-workstation interaction effects. However, by calculating the subject effect the assumptions are clearly confirmed. No attempt was made to check for interaction effects from one muscle group to another.

In addition to three ANOVAs performed on the raw EMG data, three other ANOVAs were performed on a smoothed version of the data (moving window average) and three more ANOVAs on a smoothed version of the data using a different smoothing technique, that of Savitzsky-Golay.

#### **4.10 Posture Measurement - Work Sampling**

The postural angles of interest, shoulder flexion, head/neck flexion, and wrist angle, are all in the sagittal plane. Posture ranges are defined and posture observations or samples are placed into one of the predefined ranges or categories. The proportion of a total sample which falls into a predefined range is calculated as an estimate of the proportion of time spent in a given posture range. This procedure was applied to four of the original twelve subjects. The data were collected using a video-camera with sagittal plane view, and the Promatek Vision 3000 computerized data collection system. This is essentially a computerized photogoniometer system. While work sampling typically relies upon random numbers to select sample points in time, the Vision 3000 system allows for posture samples to be captured only at regular intervals. Therefore, a systematic sample was taken, which in many circumstances is effectively the same as a true or pseudo random sample. The interval for systematic sampling here was set for one frame captured every

90 frames at a pace of 30 frames/second, or one frame every three seconds. Since the cycle times for subjects ranged from 7 to 11 seconds/cycle, this systematic sample interval was likely to provide samples which behaved very much like a randomly selected sample.

Both shoulder flexion and head/neck flexion are largely sagittal plane activities and could be readily measured using the sagittal view camera angle. However, for the hand/wrist, much task activity was observed to occur in the transverse plane, especially at activation of the wand-type controls. Therefore, the results of posture sampling for the hand/wrist are likely to be less reliable than that of the shoulder or head/neck. In addition, worksite constructs partially blocked the camera's view of hand/wrist activity at the point of control activation, further limiting validity of the hand/wrist posture sampling.

#### **4.11 Design of Experiment - Postural Analysis**

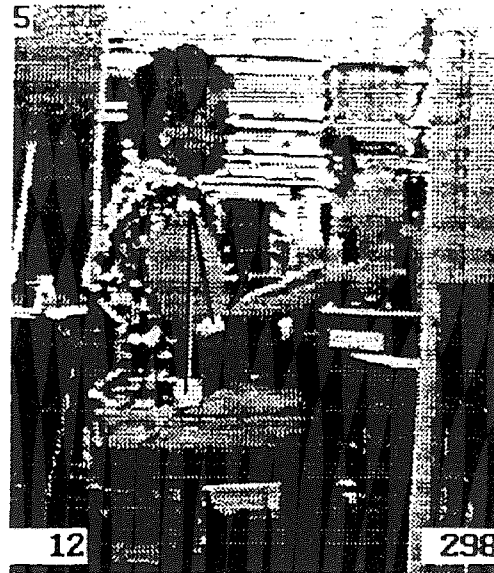
For postural analysis, hypothesis tests on proportions per postural classification were utilized to check for significant differences by comparing old and new workstation conditions for the posture of interest. Each subject acted as their own control. Since substantial limitations to the hand/wrist aspect of data collections resulted from the fact that a two-dimensional sagittal plane photogoniometer cannot measure postural angles in the transverse plane, and since the small number of subjects limited the degrees of freedom available, no attempt to run ANOVAs or paired t-tests was made for the postural analysis.



Subject 8

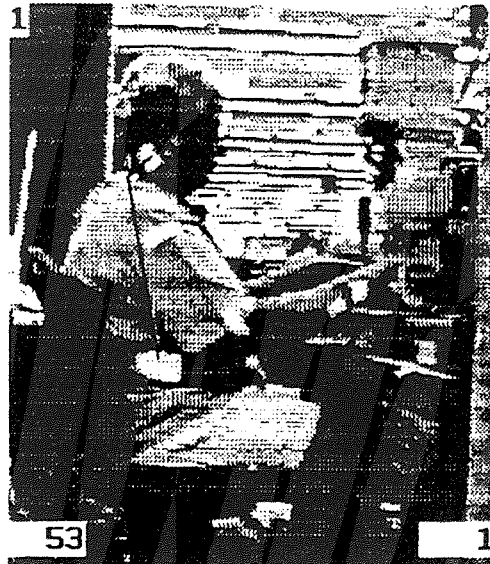
Figure 12 - Photogoniometric angle, wrist flexion





Subject 3

Figure 13 - Photogrammetric angle, shoulder flexion



Subject 2

Figure 14 - Photogoniometric angle, head/neck flexion

## 4.12 Possible Confounders

### 4.12.1 Fatigue Effects

In order to avoid possible fatigue or ordering effects, the order of workstation presentation was balanced throughout data collection. Data were collected on half of the subjects working with the old workstation, followed by working with the new workstation, while the remaining half worked with the new workstation first, then with the old workstation. Since data for subject 3 were lost and only 9 of 10 subjects were actually used in the analysis, the design for ordering is not completely balanced.

However, it was felt that ordering effects, if any, were at most quite minimal, and that the minor degree of imbalance in ordering was negligible in a practical sense.

### 4.12.2 Learning Effects

The task is relatively simple, with a learning curve of less than one week needed for an experienced worker to achieve maximum proficiency. Each worker was allowed to "practice" the task for a sufficient period on the improved worksite prior to experiment data collections to ensure that a plateau on the learning curve had been reached.

However, for at least one subject who appeared to struggle with the new controls due to their altered feel or sensitivity, a learning or forgetting effect appears to have occurred. A close review of the video of subject 10 revealed clearly that a forgetting phenomenon had occurred and that this subject was re-learning the workstation during data collections, often attempting to operate the controls several times before one successful cycling of the machine. This circumstance is likely to have increased muscle activity in at least two of the muscle groups for subject 10, and to have slowed the average cycle time - which

would also increase the integrated signal average. Consequently, the ANOVA analyses for the first run *included* this subject (subject 10). But subsequent analysis *excluded* this subject decreasing the available degrees of freedom.

#### **4.12.3 Presentation Order Effects**

The possible confounders of fatigue and learning were controlled to the extent practical as provided above. Most presentation order effects are the result of either fatigue or learning, or both. By balancing the order or sequence in which data were collected, any short term learning or forgetting, or fatigue should have been sufficiently randomized and/or controlled.

#### **4.13 Subjective Data Collection**

Subjective data collection sheets inquiring about localized fatigue, pain, or discomfort were prepared and presented to each participant. Bipolar rating scales or "visual analog scales" were modified from the University of Michigan subjective data collection forms provided at their Summer Engineering Conference on Ergonomics in 1990. The continuum scales were divided into 16 intervals, and four classifications or categories were created as follows: 1-4 (little or no pain, discomfort or fatigue), 5-8 (moderate), 9-12 (serious), and 13-16 (severe). Paired comparison t-tests on the proportions of subjects in each category for each listed body part were conducted.

#### 4.14 Workstation Design Changes

The original workstation utilized wand-type toggle controls suspended above the worktable and flat table surfaces on either side of the fixture (see figure 15). Workstation improvements included replacement of wand switches or controls with proximity activated controls. In addition to changing control type, control location was also modified. By changing control type, both the physical interface with the controls was altered and the sensitivity of the controls was different. Proximity switches were placed flat atop the table while the wand switches had been suspended more than 4.5 " above the table surface. In addition to control changes, the fixture and table height were lowered. The relative distance between the table surface and the top of the fixture was also reduced. The incoming parts tray was angled back toward the worker in order to reduce reach requirements to grasp a part. Also, the finished parts tray was modified to discourage stacking of trays of finished parts which tended to induce shoulder flexion. As an alternative, a small parts tray stand positioned directly on the floor was provided. This allowed workers to place finished trays of parts on the stand by working with, not against, gravity, and without reaching and shoulder flexion. Finally, the table was fashioned to allow the worker to move closer to the fixture. The attached diagrams illustrate the proposed and actual workstation changes. Note that the original proposals were not fully implemented due to practical problems encountered. Any positive results would likely be more dramatic had the changes been more fully implemented.

Design axioms or principles which were applied were as follows:

► ***the lower the reach target, the better the shoulder posture***

This axiom was suggested by Keyserling et al. (1989) based on computer aided postural analyses of the shoulder. Grandjean (1988) offered recommendations for standing work height based on a reference line drawn through standing elbow height measured from the floor. His recommendations indicate that work should be between two and four inches below elbow height. This notion can be extrapolated to seated work - at least as far as the shoulder is concerned - and tends to agree with Keyserling et al. (1989) placing the work well below elbow height. The likely effect of placing work as low as practical is to minimize shoulder flexion in the sagittal plane. A constraint regarding lowering work height would logically be at the point where having work any lower would tend to induce trunk flexion for either seated or standing work.

Here, by reducing the table height and the relative distance of the fixture or point of activity to the table surface, the effective point of activity for the worker was reduced. A recommendable constraint on the underside of the work table is thigh clearance for a 95th percentile person, which is reflected in the diagram of proposed workstation changes.

► ***work with, not against gravity***

This common-sense axiom was formally stated by Konz in 1990 when he offered the guideline to "use gravity, do not oppose it". However, such a straightforward guideline is still routinely violated in actual industrial settings. Here, workers stacked trays of completed parts atop the work table until the stack would no longer physically fit

the area or until the stack height approached their maximum reach capability. The effect was that workers were lifting trays of parts in severe shoulder flexion and otherwise awkward postures. By modifying the table surface to discourage stacking of trays atop the table and by providing a stacking stand on the floor below the workers' elbow height, the undesirable aspect of stacking trays of completed parts was removed. The table surface was modified by cutting a tray holder recess into the table. It was difficult to stack other trays on top of a tray placed into the recess. The same effect could also be accomplished by angling the completed parts tray holder toward the worker in a fashion similar that of the incoming parts tray holder on the modified workstation.

► *avoid static muscle loading*

Konz (1990) stated this axiom as "avoid static loads and fixed work postures". Grandjean (1988) documented the physiological and cardiovascular effects of static muscle loading, noting that bloodflow is interrupted with static loads, and that painful fatigue develops at a static load of only of 15-20% of maximum voluntary contraction (MVC) on a daily basis. In the press operator job, workers were forced to flex the shoulders in order to position the hands at a height of four to six inches above the worktable to activate the wand controls. Due to control safety features requiring that the two controls be pressed simultaneously and held for some period of time in order to activate the machine, a static load to both the shoulders and to the hands/wrists was induced. To reduce static loading, the controls were relocated to atop a lowered table surface, where the shoulders could merely rest the hands, with support, during control activations. To facilitate this change, a different type of control, one with a largely flat,

horizontal surface was utilized. In addition, the effectively lower fixture height should require less static loading of the shoulders during part insertion to the fixture, and during any part positioning at the fixture.

▸ *keep reaches within the normal range*

Another common-sense rule of thumb for the ergonomist is to design worksites to keep reaches within an anthropometrically drawn reach envelope. While static and dynamic reach envelopes differ, each has a similar semi-circular shape in each of three dimensions. Konz (1990) suggests that a "windshield wiper" shaped reach envelope be based on anthropometric dimensions assuming an elbow position moving in an arc as the forearm moves, called the Squires curve. Alternatively, Konz suggests that the recommended area be based on direct anthropometric estimations of the effective reach envelope as offered by Konz. To delineate this area, the incoming parts tray was angled toward the worker and the completed parts tray stacking stand was located inside the reach envelope below the elbow height.

▸ *allow operators to work with minimal flexing, extending, or deviating wrist*

Given the preceding discussion of an association between cumulative trauma disorders and hand/wrist posture, minimization of extremes of hand/wrist posture is justified. Konz (1990) states this axiom as "reduce cumulative trauma disorders". To accomplish this, controls were relocated so that the wrist can be held neutral at control activation. When using wand controls at the old workstation, operators' wrists were ulnarly deviated and fingers extended at control activation.



► *provide visual targets at a location that induces a line of sight angle at or near the preferred line of sight angle*

Kroemer and Hill (1986) conducted a study which identified the average preferred line of sight angle for viewing as  $29^\circ$  below horizontal with a standard deviation of  $11.6^\circ$ . The researchers were surprised to learn that the viewing angle tended to be much steeper and the visual target much lower than human factors texts had recommended to date 1986. Grandjean (1988) pondered the findings but dismissed them as having been due to special experimental conditions and relatively short duration. Yet, Grandjean (1988) also cites a study by Lehman and Stier which found that seated subjects preferred an average line of sight angle of  $38^\circ$  below horizontal. Nevertheless, the authors maintained the previously accepted recommendation of a "normal" line of sight at  $10-15^\circ$  below horizontal. This question is perhaps not yet fully answered, as many training programs for VDT operators still recommend a screen height with screen just at or below eye level, effectively recommending the older  $10-15^\circ$  line of sight angle. Yet when reading, seldom does one find a person holding a book in front of the face on a horizontal plane at or just below the eyes - perhaps in part because of the static loading of the arms such a position would entail. If the results of the Kroemer and Hill (1986) study are correct, a press operator should not only be able to *tolerate* a lowered fixture or visual target, but should actually *prefer* this arrangement.

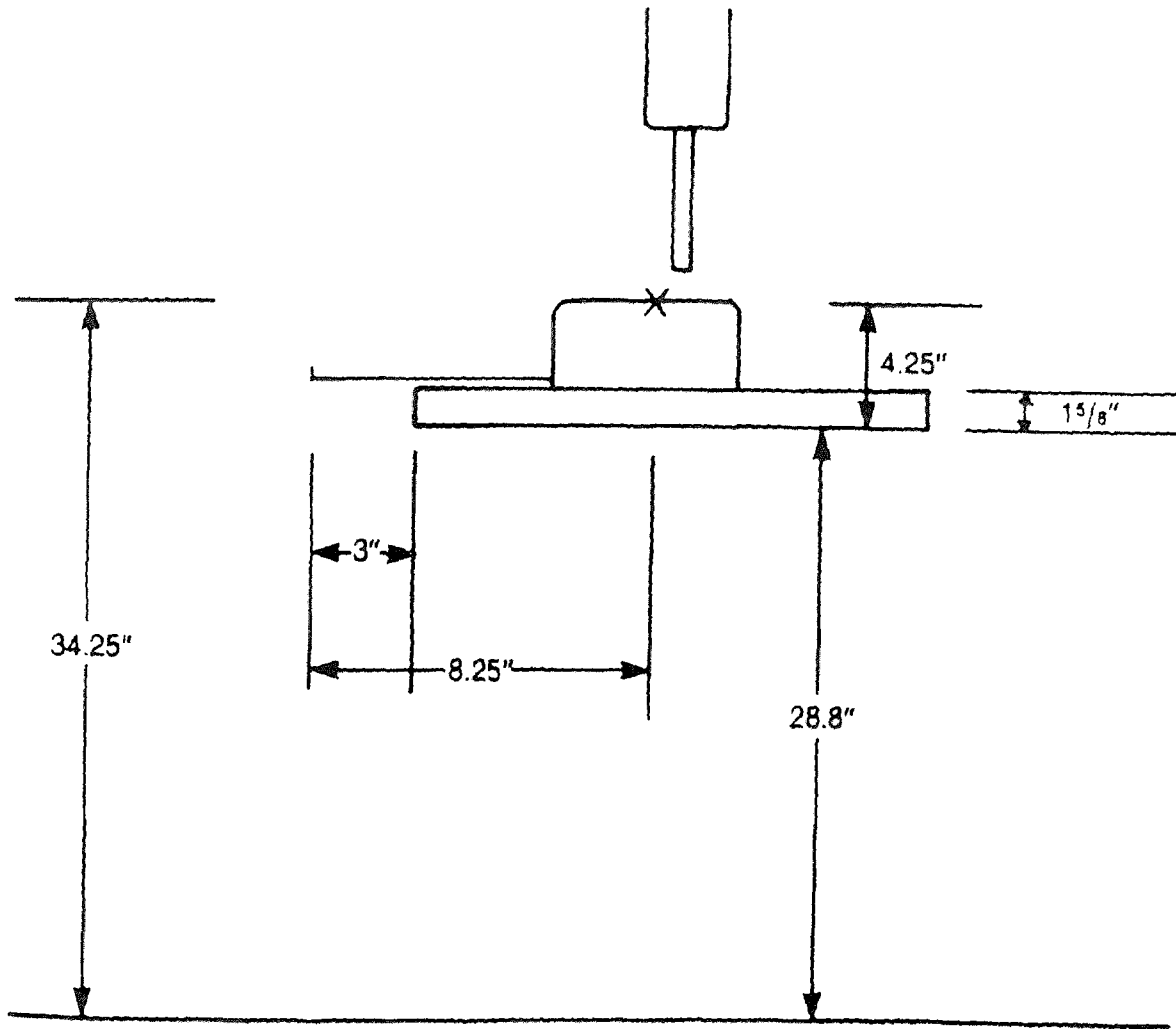
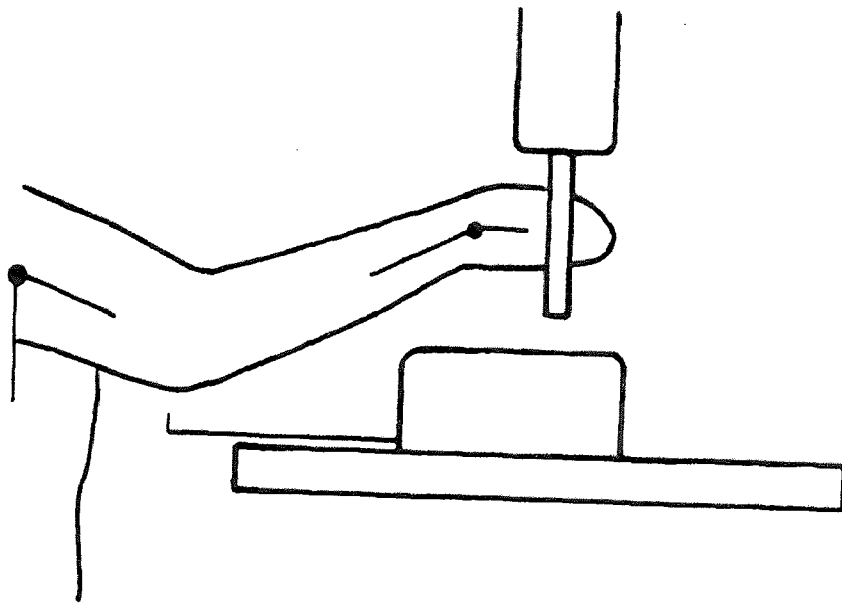
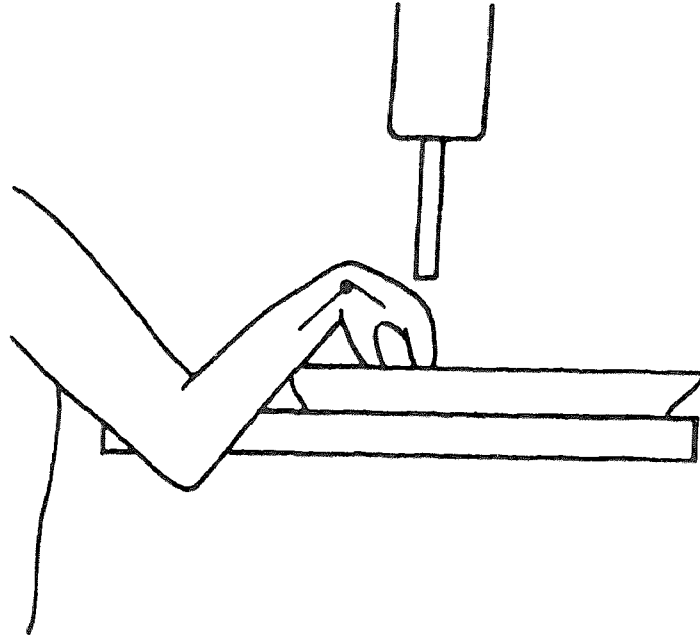


Figure 15 - A side view of the old workstation prior to any ergonomic changes.



**Figure 16** - At the old workstation, operation of the wand controls repeatedly induced shoulder flexions with a momentary static load during control activation.



**Figure 17** - At the old workstation, the wrists were repeatedly flexed with a pinch grip.

By reducing the effective height of the fixture and small parts trays and measuring muscle activity in the upper trapezius, some insight into the question of preferred area of visual target should be gained.

#### 4.15 Expected Results

Results are expected to include significantly reduced EMG readings for arm and shoulder areas for the prototype workstation compared to the old workstation. The question of muscle activity at the upper trapezius due to a changed line of sight angle is uncertain, but the results should provide some insight. For a positive outcome, no significant difference in head/neck muscle activity is desired. A primary purpose of the experiment is to learn whether or not hand/wrist and shoulder muscle activity can be reduced significantly by lowering worksite implements without adding significantly to the head/neck muscle load.

For improved postures, shoulder flexion and wrist flexion in the sagittal plane should be significantly reduced, whereas head/neck flexion may not be significantly affected. The posture results will be most credible for the shoulder and head/neck postures, and much less so for the hand/wrist since much activity of the hand/wrist in the press operator job occurs in the transverse plane, and could not be measured by a two dimensional photogoniometer.

A significant reduction in muscle activity is an indication that the probability of acute or chronic muscle fatigue has been significantly reduced. Therefore, the risk of cumulative trauma as it relates to force of exertion has also been reduced. Such a finding would also indicate that operators have been provided a workstation which allows more efficiency, allowing them to accomplish the same work in the same time with less effort.

If postures are significantly improved so that a greater proportion of work time is spent in a neutral posture classification, then the risk for CTDs associated with posture would have been reduced.

Since the originally proposed changes to the worksite could not be fully implemented due to practical constraints, any results should be less compelling than they might have been had practical constraints not prevented full implementation. If significance is achieved in spite of this situation, one may surmise that full ergonomic worksite changes have an even greater potential for reduction of CTD risk than measured here.

Symptoms surveys allow operators to indicate their preferences and feelings about the workstations. A significant reduction in symptoms would tend to indicate a significantly improved workstation.

#### 4.16 Statistical Analysis

EMG analyses were conducted using the Statistical Analysis System (SAS) software. The following SAS code was utilized to run the analyses:

```
data chan1;
  infile 'chan1.dat';
  input workst $ 7-11 subj $ 31-33 obs 56-65;
run;

proc glm data=chan1;
  classes workst subj obs;
  model obs=workst subj workst*subj / ss1 ss2 ss3 ss4;
  means workst subj workst*subj / duncan tukey snk gt2 scheffe;
run;
```

The general linear model (GLM) analysis of variance (ANOVA) was utilized since this SAS technique is appropriate for an unbalanced design of experiment, in which the cell sizes for each subject and workstation condition were *not* equal. Four different types of

sum of square values (SS1, SS2, SS3, and SS4) were calculated. Type III and type IV sum of squares, sometimes referred to as *partial sum of squares*, are considered by many investigators to be the most desirable outputs, according to the SAS/STAT User's Guide Volume 2. Type II, type III and type IV sum of squares are not dependant on the order of effects specified in the model, while type I SS is model-order dependant. For unbalanced designs, hypotheses for type I and type II SS are generally functions of the cell counts. This is not true for type III and type IV SS. When no cells are missing, type III and type IV sum of squares are the same. This feature confirmed that all cells were read and utilized by the computer.

For means tests, Duncan's test (DUNCAN), Tukey's test (TUKEY), Student Newman-Keul's test (SNK), Scheffe's test (SCHEFFE), and the studentized maximum modulus (GT2) were utilized. The GT2 was used since this test is for unequal cell sizes.

## CHAPTER 5

### RESULTS

#### 5.1 EMG

Analysis of variance and hypothesis tests on means reveal that hand/wrist muscle activity at the new workstation had decreased significantly (.05 level) compared to muscle activity for the old workstation. The interaction of workstation and subject was also significant at the five percent level. Significance was achieved for the group for both raw and each method of smoothed data. A review of the differences between means reveals the general nature of the results, with seven of nine of the differences positive. Subject #6 experienced a *dramatic* reduction in hand/wrist muscle activity. Significance was confirmed using Duncan's means test, Tukey's studentized range test, Student Newman-Keuls, Scheffe's test, and studentized maximum modulus. All tests agreed. The results of the General Linear Model (GLM) ANOVA and means tests appear in Tables 4 and 5. Examples of the complete SAS outputs are shown in Appendix D .

subj 1	subj 2	subj 4	subj 5	subj 6	subj 7	subj 8	subj 9	sub10
.1823	.1386	2.445	2.427	15.983	2.761	2.386	-1.892	-4.045

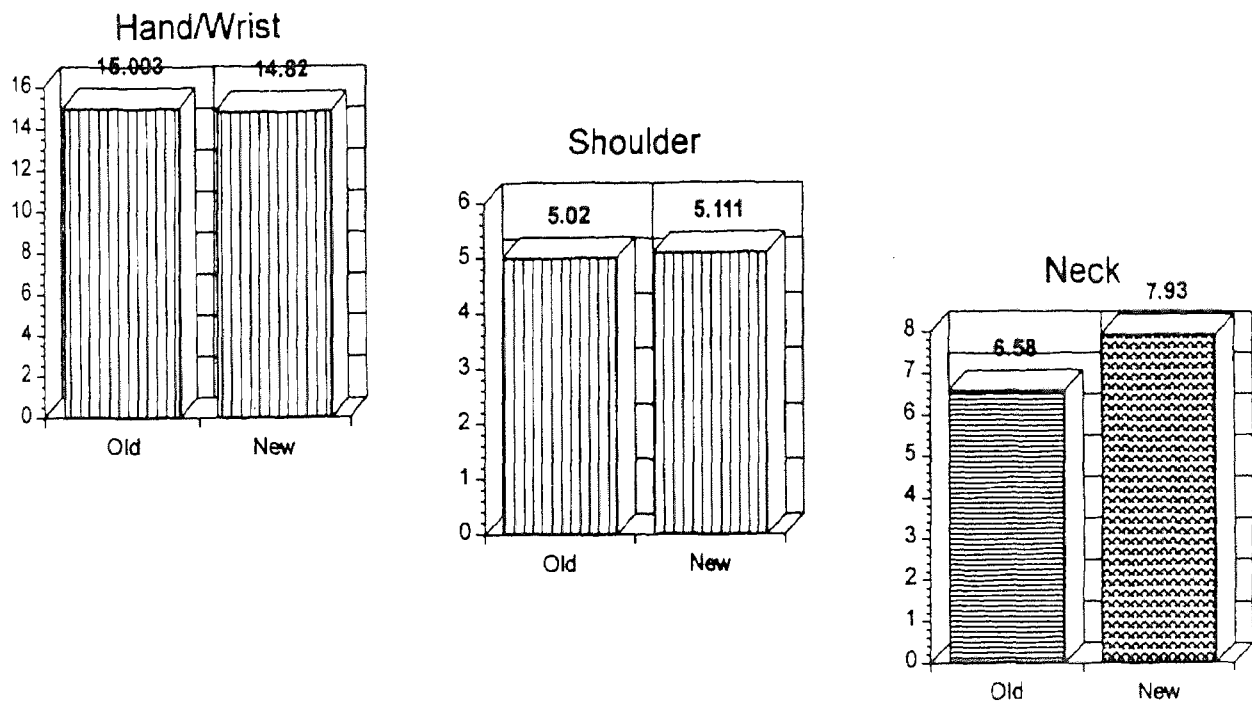
**Table 3** Hand/Wrist - Differences in Mean Muscle Activity (old-new) based on raw data for Channel 1. Note that most values are positive, indicating improvement.



For the shoulder, the difference from old to new workstation was not significant with raw data. However, crosstalk and noise in the raw data could disguise a meaningful difference. ANOVAs for each of the smoothed data techniques clearly revealed a significant reduction in muscle activity for the shoulder at the five percent level.. Significance was confirmed using Duncan's means test, Tukey's studentized range test, Student Newman-Keuls, Scheffe's test, and studentized maximum modulus. All tests agreed. The results of the General Linear Model (GLM) ANOVA and means tests appear in tables 8 and 9. Examples of complete SAS outputs are shown in Appendix D .

For the upper trapezius muscle, activity significantly increased with the new workstation compared to the old workstation ( $\alpha=.05$ ). This result was true for both raw and smoothed data. Significance was confirmed using Duncan's means test, Tukey's studentized range test, Student Newman-Keuls, Scheffe's test, and studentized maximum modulus. All tests agreed. The results of the General Linear Model (GLM) ANOVA and means tests appear in Tables 10-12. Examples of the complete SAS outputs are shown in Appendix D.

Data for each subject were reviewed individually and confidence intervals were calculated for each workstation condition and muscle group. These allowed a comparison for significance within each subject and muscle group. The results are provided on the following bar charts, Figures 18 through 28. Significance is indicated by the bar type. Those with different bar types are significantly different ( $\alpha=.05$ ). Those with the same bar type are not significantly different.



**Figure 18** - An example of EMG results for raw data. Shown are results for subject #1. Statistical significance is indicated by bar type.

**The SAS System General Linear Models Procedure**

Source	DF	Type I SS	Mean Square	F Value	Pr > F
WORKST	1	394.518253	394.518253	32.77	0.0001
SUBJ	8	45335.929816	5666.991227	470.69	0.0001
WORST*SUBJ	8	2787.011018	348.376377	28.94	0.0001

Dependent Variable: OBS

Source	DF	Type II SS	Mean Square	F Value	Pr > F
WORKST	1	350.563240	350.563240	29.12	0.0001
SUBJ	8	45335.929816	5666.991227	470.69	0.0001
WORST*SUBJ	8	2787.011018	348.376377	28.94	0.0001

Source	DF	Type III SS	Mean Square	F Value	Pr > F
WORKST	1	525.536279	525.536279	43.65	0.0001
SUBJ	8	45278.906152	5659.863269	470.10	0.0001
WORST*SUBJ	8	2787.011018	348.376377	28.94	0.0001

Source	DF	Type IV SS	Mean Square	F Value	Pr > F
WORKST	1	525.536279	525.536279	43.65	0.0001
SUBJ	8	45278.906152	5659.863269	470.10	0.0001
WORST*SUBJ	8	2787.011018	348.376377	28.94	0.0001

**Table 4** - ANOVA results for the hand/wrist muscle group. Significance was identified for all effects.

Means With The Same Letter Are Not Significantly Different.

Duncan Grouping	Mean	N	WORKST
A	22.7730	455	100.0
B	21.4680	472	200.

**Table 5** - Means tests for hand/wrist data revealed that the workstation effect was significant improvement.

Subject #10 shows increased muscle activity for all three muscle groups. This result is not consistent with the other subjects, all of whom show at least one muscle group with decreased activity. Consequently, the video of subject #10 was reviewed to check for possible confounding factors. The video reveals that subject #10 appears to be learning or relearning the new workstation during data collections, occasionally attempting to operate the press controls several times before successfully cycling the machine. Since the new controls have different sensitivity compared to the older, wand-type controls, a brief learning curve was known to exist. Perhaps subject #10 either never fully learned the job, or a forgetting phenomenon occurred.

Consequently, the ANOVAs were also calculated *excluding* data for subject #10. The results for both hand/wrist and for shoulder muscle groups were unchanged. For the upper trapezius/neck a marginal but significant ( $\alpha=.05$ ) workstation effect, an increase in muscle activity, was revealed for type I sum of squares only. For type II SS, type III SS, and type IV SS, the workstation effect was not significant. However, workstation-subject interaction effects were significant for all types of sum of square ANOVAs. For the type I SS workstation effect, the increase in muscle activity was not significant at the one percent level ( $p=0.022$ ). Means tests confirmed significance at the five percent level. The results of the General Linear Model (GLM) ANOVA and means tests appear in Tables 11 and 12. Examples of the complete SAS outputs are shown in Appendix D .

## 5.2 Distributions

Goodness of fit tests were applied to the data to test for normality. The tests were conducted via the SIMAN Output Processor. Of fifty distributions tested, normality

could not be rejected for 21 at the five percent level using the Chi-Square goodness of fit test. A best-fit parameter was identified for each distribution. Examples of the goodness of fit and best-fit results appear in Appendix C.

### 5.3 Posture

For the shoulder, flexions less than 40° became a significantly ( $\alpha=.05$ ) greater proportion of the posture sample for two of four workers for which samples were taken. One of the operators experienced a significant ( $\alpha=.05$ ) increase in the proportion of time shoulder flexions were greater than 40°. The fourth subject experienced non-significant changes in shoulder posture. These results suggest that reduction in shoulder flexions probably contributed substantially to the significant ( $\alpha=.05$ ) decrease in anterior deltoid muscle activity as identified by the EMG .

For neck postures, two of four operators experienced non-significant changes. One operator experienced a significant increase in neck flexion equal to or greater than 30°. The remaining subject experienced a significant decrease in neck flexions equal to or greater than 30°. These mixed results indicate that lowering the visual target does not guarantee increased neck flexions of greater than 30° as one might expect.

For the hand/wrist, the results include a significant ( $\alpha=.05$ ) increase in the proportion of time spent in sagittal plane flexion greater than 30° for two of four subjects. The remaining two subjects experienced non-significant changes. These results must be regarded with caution since the two-dimensional photogoniometer only recorded postures in the sagittal plane. Much of the hand/wrist activity for the press operator job occurred

	<u>Sub 2 - Old</u>	<u>Sub 2 - New</u>	<u>Z</u>	<u>Sub 12 - Old</u>	<u>Sub 12 - New</u>	<u>Z</u>
Flexion > 30°	.34	.26	1.564	.07	.19	2.28*
Normal	.65	.73	1.564	.92	.80	2.33*
Extension > 30°	0 n = 139	0 n = 146	-	0 n = 78	0 n = 157	-
	<u>Sub 3 - Old</u>	<u>Sub 3 - New</u>	<u>Z</u>	<u>Sub 8 - Old</u>	<u>Sub 8 - New</u>	<u>Z</u>
Flexion > 30°	.11	.12	.431	.15	.39	-4.315*
Normal	.86	.87	.110	.84	.58	-4.315*
Extension > 30°	0 n = 82	0 n = 155	-	.0 n = 138	.017 n = 112	-1.5

Z Critical = 1.96

**Table 13** - An example of posture results. Shown are posture results for the hand/wrist, which show mixed results. Since much hand/wrist activity occurred in the transverse plane, which was not measured with the 2-D photogoniometer, these results are not particularly revealing.

in the transverse, rather than sagittal plane. As a consequence, the most valuable and reliable posture results are those for the shoulder and neck postures, which were overwhelmingly sagittal plane postures.

#### 5.4 Symptoms

The following table represents the proportion of subjects responding on symptoms survey forms that they experienced pain in the "serious" to "severe" category per body part, or 8-16 on the visual analog scale.

	neck	shoulder	wrist	hand	finger
old workstation	.10	.20	.30	.20	.20
new workstation	0.0	.10	.10	0.0	.10

**Table 16** Symptoms results summary - the proportion of subjects reporting serious to severe pain for each body area shown

While significance cannot be tested, the results appear to reflect that at least some of the operators found the new workstation more comfortable compared to the old workstation.

Full results from the symptoms surveys are found in Appendix B.

#### 5.5 Discussion

EMG, posture, and symptom results tend to agree that physical changes to the worksite have significantly reduced the risk for cumulative trauma disorders of the hands/wrists and shoulders. The risk for neck symptoms was increased due to a greater proportion of



time in neck flexions of greater than  $40^\circ$ , or due to increased muscle activity in the upper trapezius, or both. However, the finding for both postural angles and muscle activity was marginal. There appears to be some tradeoff between reducing the reach target for the benefit of the shoulders and hands, and reducing the height of the visual target which may impact the line of sight angle and the associated neck posture and/or upper trapezius muscle activity. However, any detriment to the neck upper trapezius muscles was not dramatic or clear, while the benefit to the hand/wrist muscle activity was. Several subjects (#4, #5, #6, and #7) actually experienced a *decrease* in muscle activity for the upper trapezius.

The question of line of sight angle and head posture was addressed in a VDT related study (Gallimore and Brown, 1993) who found that a viewing device which substantially reduced the height of the visual target compared to more common VDT monitor placements significantly changed neck posture. However, the postural change could not be associated with changes in symptoms of the neck or visual performance. The Hill and Kroemer study (1986), which placed the preferred line of sight angle at much lower than is commonly practiced in either small parts assembly and/or press operator jobs or VDT jobs, is noteworthy in this matter. In the American National Standard for Human Factors Engineering of Visual Display Terminal Workstations (ANSI/HFS100, 1988) the Hill and Kroemer study is cited, with the recommended range for line of sight angle given at from  $0$  to  $-60^\circ$  from the horizontal plane of the eyes. The marginal findings here regarding a workstation effect on upper trapezius muscle activity, due to lowering the fixture height, raise further questions about the preferable or recommendable visual target height when this point in space must also be a reach target for the hands. Of course, since the

shoulders position the hands. all three muscle groups are affected by the target location. Consequently, the problem is one of optimization for each individual, with a goal to minimize hand/wrist, shoulder, and upper trapezius muscle activity simultaneously by placing the visual/reach target at the optimum location in space for that individual.

## 5.6 Conclusions and Recommendations

Benefits to both hand/wrist and to shoulder muscle activity here were clearly identified as a consequence of lowering the fixture, table and parts trays, and controls. In other words, both hand/wrist and shoulder muscle activity were reduced by lowering all reach targets somewhat. This outcome is in accordance with expectations. The evidence also suggests that operators experienced a marginal but significant increase in neck or upper trapezius muscle activity, perhaps due to the steeper line of sight angle and greater head flexion experienced by some operators when provided with the lowered workstation. However, when subject #10 was excluded, the workstation effect for muscle activity was *not* significant for type III and type IV SS ANOVAs for the upper trapezius. A compromise between significantly improved outcomes of secondary measures of risk for both hand/wrist and for shoulder disorders versus possibly increased upper trapezius muscle activity appears reasonable. It is justifiable based on the minimal effect to upper trapezius muscles versus clearly identified improvements for both hand/wrist and shoulder muscle activity. Employers may find such a compromise to be particularly worthwhile for those operations that have historically experienced costly workers compensation injury losses for hand/wrist and/or shoulder disorders, but relatively few for neck disorders.

Consequently, the following recommendations can be offered:

1) Reduce, to the extent practical, the effective reach target or point of activity for fixtures, parts trays, and controls. Thigh clearance under the table determines an absolute constraint; but increases to upper trapezius muscle activity due to greater head flexion and the need to counter the moment created when the head is tilted forward may constitute a constraint for some individuals.

2) Use controls of a type which allow a neutral wrist posture activation, such as the flat surface proximity-type controls utilized here versus the wand-type controls which encourage repeated extensions and deviations of the wrists.

3) Provide all implements or items within a "normal" working area or reach envelope, preferring a sequence that works with, not against, gravity. Parts trays can be angled toward workers, while finished parts trays can be located on a small stand directly on the floor.

The methodology employed here regarding utilization of integrated EMG signals over time in a within-subjects design was useful for revealing workstation effects for individuals and for the group as a whole. This was accomplished without the need to normalize the readings by strength (proportion of a maximum voluntary contraction). Such a change would significantly increase analysis time and effort, and could possibly introduce additional artifacts and error sources to the data. Relative increases or decreases in muscle activity could still be assessed across workstation conditions. For the

practitioner attempting to assess effects of various aspects of workstation design, minimizing analysis time and effort is paramount. This method would be especially appropriate when a limited number of workstation settings or equipment choices are available in a practical sense. These settings could be tested and compared without the need to test a wide range of possible settings or choices. By placing old and new workstations side by side for testing of subjects in each condition in close proximity of time, any error associated with electrode placements or repositioning are avoided. Also, by balancing or randomizing the sequence of data collections (old workstation versus new), any ordering effects such as learning or fatigue are averaged out and controlled. While statistically significant improvements were identified, the threshold at which improvements reach clinical significance in the etiology of disorders is not currently known. Future research may reveal more information about clinical significance, and will probably be accomplished through prospective epidemiological studies. However, for employers seeking to utilize the safest job design settings available among a limited number of choices, statistically significant improvement is a far better criterion upon which to base design decisions than guesses or assumptions, and may well have clinical significance for many subjects.

# **Appendix A**

## **Examples of Data Distribution Goodness of Fit Chi-Square Tests**

```
=====
BEST FIT SUMMARY
```

Data File: sl-c3-n.dat

Function	Sq Error
Lognormal	0.00971
Erlang	0.0106
Gamma	0.0107
Beta	0.0196
Weibull	0.0203
Normal	0.022
Triangular	0.0351
Uniform	0.122
Exponential	0.17

```
=====
Data File: sl-c3-n.dat
```

Histogram Range: 5.24 to 10.8

No. of Data Points = 56  
No. of Intervals = 7

Min Data Value = 5.7  
Max Data Value = 10.3

Sample Mean = 7.93  
Sample Std Dev = 0.887

Distribution Function: Normal

```
=====
SIMAN USAGE: NORM(7.93, 0.879)
```

Sq Error = 0.022

Chi Square Test:  
No. of intervals = 4  
Degrees of freedom = 1  
Critical value = 4.46  
Corresponding p-value = 0.0369

Kolmogorov-Smirnov Test:  
Critical value = 0.098  
Corresponding p-value = > 0.15

```
=====
```

Int. No.	No. of Data Pts.	x	Probability Density		Cumulative Distribution	
			Data	Function	Data	Function
1	1	6.030e+00	0.018	0.014	0.018	0.015
2	4	6.820e+00	0.071	0.088	0.089	0.103
3	21	7.610e+00	0.375	0.254	0.464	0.357
4	15	8.400e+00	0.268	0.346	0.732	0.702
5	12	9.190e+00	0.214	0.221	0.946	0.924
6	2	9.980e+00	0.036	0.066	0.982	0.990
7	1	1.077e+01	0.018	0.009	1.000	0.999

```
=====
BEST FIT SUMMARY
```

Data File: s2-c2-o.dat

Function	Sq Error
Erlang	0.00275
Gamma	0.00303
Triangular	0.00433
Weibull	0.00473
Lognormal	0.00512
Beta	0.00636
Normal	0.0111
Uniform	0.0477
Exponential	0.0924

```
=====
Data File: s2-c2-o.dat
```

Histogram Range: 16 to 26

No. of Data Points = 57

No. of Intervals = 7

Min Data Value = 16.6

Max Data Value = 25.1

Sample Mean = 20.7

Sample Std Dev = 2.12

Distribution Function: Normal

```
=====
SIMAN USAGE: NORM(20.7, 2.1)
```

Sq Error = 0.0111

Chi Square Test:

No. of intervals = 5

Degrees of freedom = 2

Critical value = 1.75

Corresponding p-value = 0.434

Kolmogorov-Smirnov Test:

Critical value = 0.0651

Corresponding p-value = > 0.15

```
=====
```

Int. No.	No. of Data Pts.	x	Probability Density		Cumulative Distribution	
			Data	Function	Data	Function
1	1	1.742e+01	0.018	0.048	0.018	0.050
2	12	1.885e+01	0.211	0.131	0.228	0.191
3	14	2.027e+01	0.246	0.231	0.474	0.422
4	12	2.169e+01	0.211	0.262	0.684	0.684
5	10	2.311e+01	0.175	0.192	0.860	0.876
6	5	2.454e+01	0.088	0.090	0.947	0.966
7	3	2.596e+01	0.053	0.027	1.000	0.994

Data File: s2-c2-n.dat

Histogram Range: 14 to 27

No. of Data Points = 60  
No. of Intervals = 7

Min Data Value = 14.6  
Max Data Value = 27

Sample Mean = 20.9  
Sample Std Dev = 2.71

Distribution Function: Erlang

=====  
SIMAN USAGE: 14 + ERLA(1.15, 6)

Sq Error = 0.00653

Chi Square Test:

No. of intervals = 5  
Degrees of freedom = 2  
Critical value = 1.5  
Corresponding p-value = 0.479

Kolmogorov-Smirnov Test:

Critical value = 0.0613  
Corresponding p-value = > 0.15

=====  
Int. No. of Probability Cumulative  
No. Data Pts. x Density Distribution  
-----  
Data Function Data Function  
1 1 1.586e+01 0.017 0.006 0.017 0.006  
2 4 1.771e+01 0.067 0.101 0.083 0.108  
3 15 1.957e+01 0.250 0.246 0.333 0.354  
4 18 2.143e+01 0.300 0.268 0.633 0.622  
5 12 2.329e+01 0.200 0.191 0.833 0.813  
6 4 2.514e+01 0.067 0.106 0.900 0.919  
7 6 2.700e+01 0.100 0.049 1.000 0.968  
=====

BEST FIT SUMMARY

Data File: s2-c2-n.dat

Function	Sq Error
-----	-----
Erlang	0.00653
Gamma	0.00797
Weibull	0.0116
Normal	0.0134
Triangular	0.0136
Lognormal	0.0139
Beta	0.0226
Uniform	0.0688
Exponential	0.128



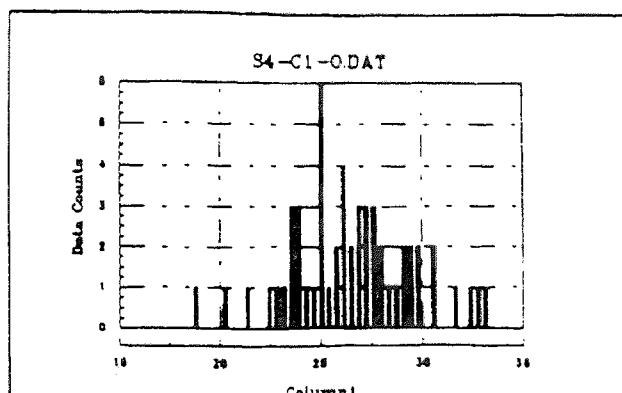
## **Appendix B**

**Examples of Raw, Smoothed, and Savitzsky-Golay Filtered Data**

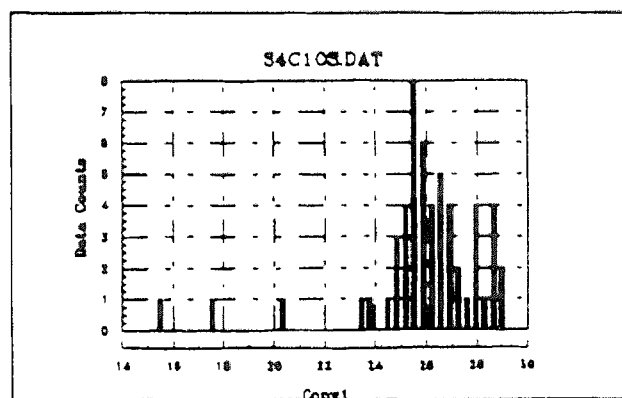
**Per Workstation, Muscle Group, Subject**

Comparison of raw and smoothed data for subject 4, channel 1 (hand/wrist) for the old workstation

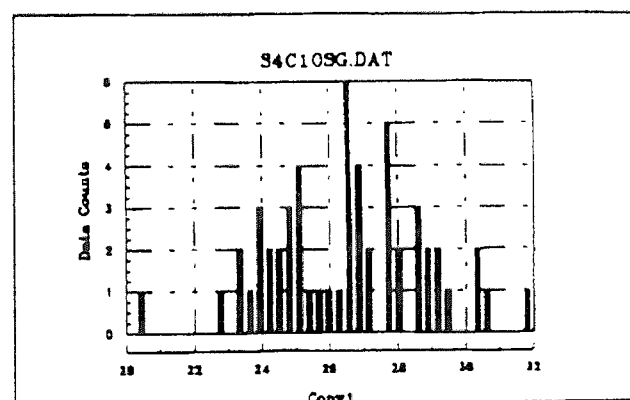
*raw*



*smoothed (moving window average)*  
 $nl = nr = 2$

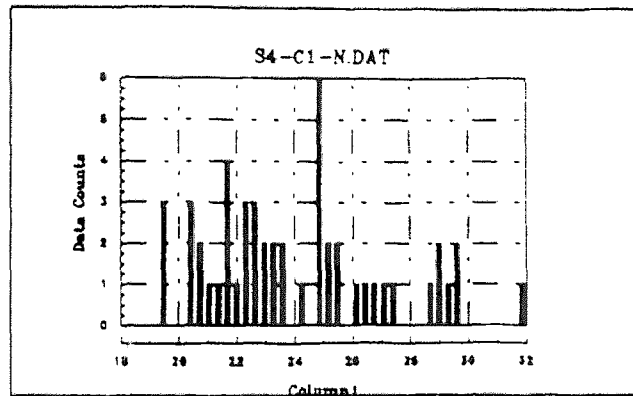


*smoothed (Savitzsky-Golay)*  
 $nl = nr = 3$

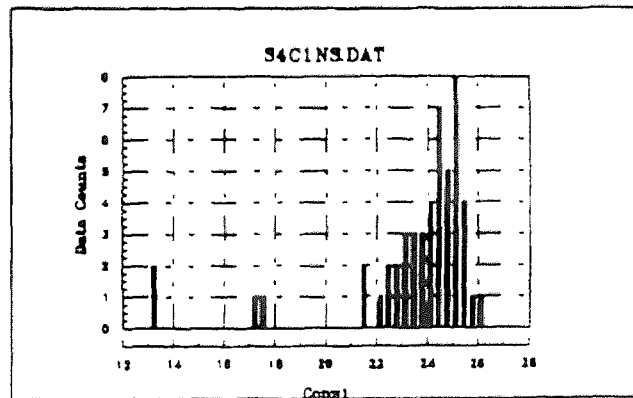


Comparison of raw and smoothed data for subject 4, channel 1 (hand/wrist) for the new workstation

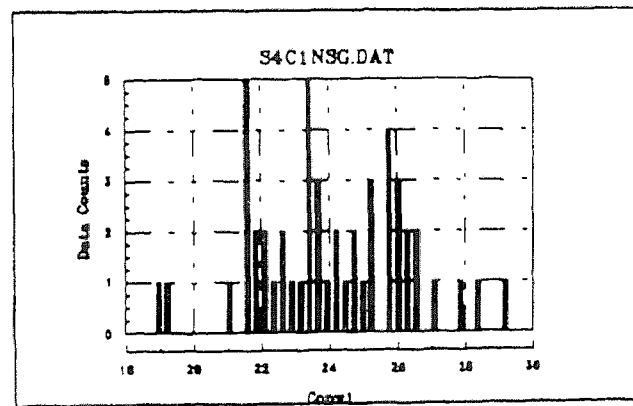
raw



smoothed (moving window average)  
 $nl = nr = 2$

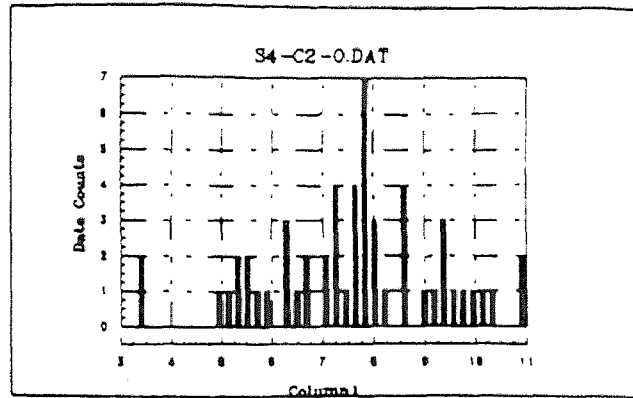


smoothed (Savitzsky-Golay)  
 $nl = nr = 3$

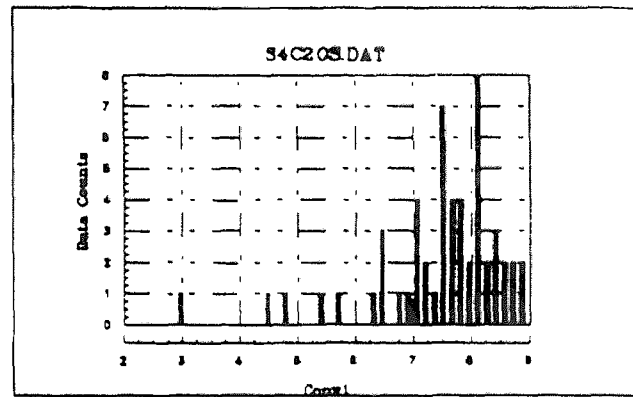


Comparison of raw and smoothed data for subject 4, channel 2 (anterior deltoid/shoulder) for the old workstation

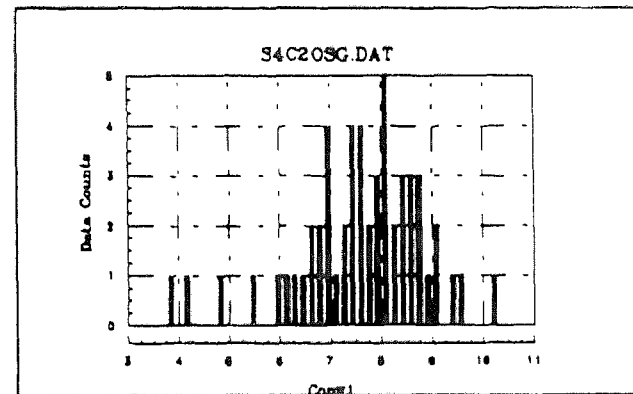
raw



smoothed (moving window average)  
 $nl = nr = 2$



smoothed (Savitzsky-Golay)  
 $nl = nr = 2$



# Appendix C

## Symptoms Survey Results

ACCOUNT:  
symptoms with old workstation  
ACCOUNT SURVEY DATE:  
December 1993

LOCATION:  
0

## DATA DISTRIBUTION SUMMARY

BODY PARTS FROM

	NECK			SHOULDER			CHEST		
	RNG	FREQ	%	RNG	FREQ	%	RNG	FREQ	%
RIGHT AREA	4	8	80	4	7	70	4	9	90
DATA	8	2	20	8	1	10	8	0	0
DISTRIBUTION	12	0	0	12	2	20	12	1	10
	16	0	0	16	0	0	16	0	0
# of Resp:		10	0			20			10
LEFT AREA	4	8	80	4	7	70	4	9	90
DATA	8	2	20	8	1	10	8	0	0
DISTRIBUTION	12	0	0	12	2	20	12	1	10
	16	0	0	16	0	0	16	0	0
			0			20			10

BODY PARTS BACK

	NECK			SHOULDER			UPPER BACK			LOWER BACK		
	RNG	FREQ	%	RNG	FREQ	%	RNG	FREQ	%	RNG	FREQ	%
RIGHT AREA	4	7	70	4	6	60	4	8	80	4	7	70
DATA	8	2	20	8	3	30	8	0	0	8	3	30
DISTRIBUTION	12	1	10	12	1	10	12	1	10	12	0	0
	16	0	0	16	0	0	16	1	10	16	0	0
# of Resp:		10	10			10			20			0
LEFT AREA	4	7	70	4	6	60	4	8	80	4	7	70
DATA	8	2	20	8	3	30	8	0	0	8	3	30
DISTRIBUTION	12	1	10	12	1	10	12	1	10	12	0	0
	16	0	0	16	0	0	16	1	10	16	0	0
			10			10			20			0

SHEET

T

ELBOW			WRIST			HAND			FINGER		
RNG	FREQ	%	RNG	FREQ	%	RNG	FREQ	%	RNG	FREQ	%
4	9	90	4	5	50	4	6	60	4	8	80
8	0	0	8	2	20	8	2	20	8	0	0
12	1	10	12	1	10	12	1	10	12	2	20
16	0	0	16	2	20	16	1	10	16	0	0
		10			30			20			20
4	9	90	4	5	50	4	6	60	4	7	70
8	0	0	8	2	20	8	2	20	8	1	10
12	1	10	12	1	10	12	1	10	12	2	20
16	0	0	16	2	20	16	1	10	16	0	0
		10			30			20			20

ELBOW			WRIST			HAND			FINGER		
RNG	FREQ	%	RNG	FREQ	%	RNG	FREQ	%	RNG	FREQ	%
4	9	90	4	6	60	4	7	70	4	9	90
8	0	0	8	1	10	8	1	10	8	0	0
12	0	0	12	2	20	12	1	10	12	1	10
16	1	10	16	1	10	16	1	10	16	0	0
		10			30			20			10
4	9	90	4	6	60	4	7	70	4	9	90
8	0	0	8	1	10	8	1	10	8	0	0
12	0	0	12	2	20	12	1	10	12	1	10
16	1	10	16	1	10	16	1	10	16	0	0
		10			30			20			10

ACCOUNT:  
symptoms with new workstation  
ACCOUNT SURVEY DATE:  
december 1993

LOCATION:  
0

## DATA DISTRIBUTION SUMMARY

BODY PARTS FROM

	NECK			SHOULDER			CHEST		
	RNG	FREQ	%	RNG	FREQ	%	RNG	FREQ	%
RIGHT AREA	4	8	80	4	7	70	4	9	90
DATA	8	2	20	8	2	20	8	0	0
DISTRIBUTION	12	0	0	12	1	10	12	1	10
	16	0	0	16	0	0	16	0	0
LEFT AREA	4	8	80	4	7	70	4	9	90
DATA	8	2	20	8	2	20	8	1	10
DISTRIBUTION	12	0	0	12	1	10	12	0	0
	16	0	0	16	0	0	16	0	0

BODY PARTS BACK

	NECK			SHOULDER			UPPER BACK			LOWER BACK		
	RNG	FREQ	%	RNG	FREQ	%	RNG	FREQ	%	RNG	FREQ	%
RIGHT AREA	4	9	90	4	8	80	4	8	80	4	8	80
DATA	8	1	10	8	2	20	8	1	10	8	2	20
DISTRIBUTION	12	0	0	12	0	0	12	1	10	12	0	0
	16	0	0	16	0	0	16	0	0	16	0	0
LEFT AREA	4	9	90	4	7	70	4	8	80	4	8	80
DATA	8	1	10	8	2	20	8	1	10	8	2	20
DISTRIBUTION	12	0	0	12	1	10	12	1	10	12	0	0
	16	0	0	16	0	0	16	0	0	16	0	0



SHEET

T

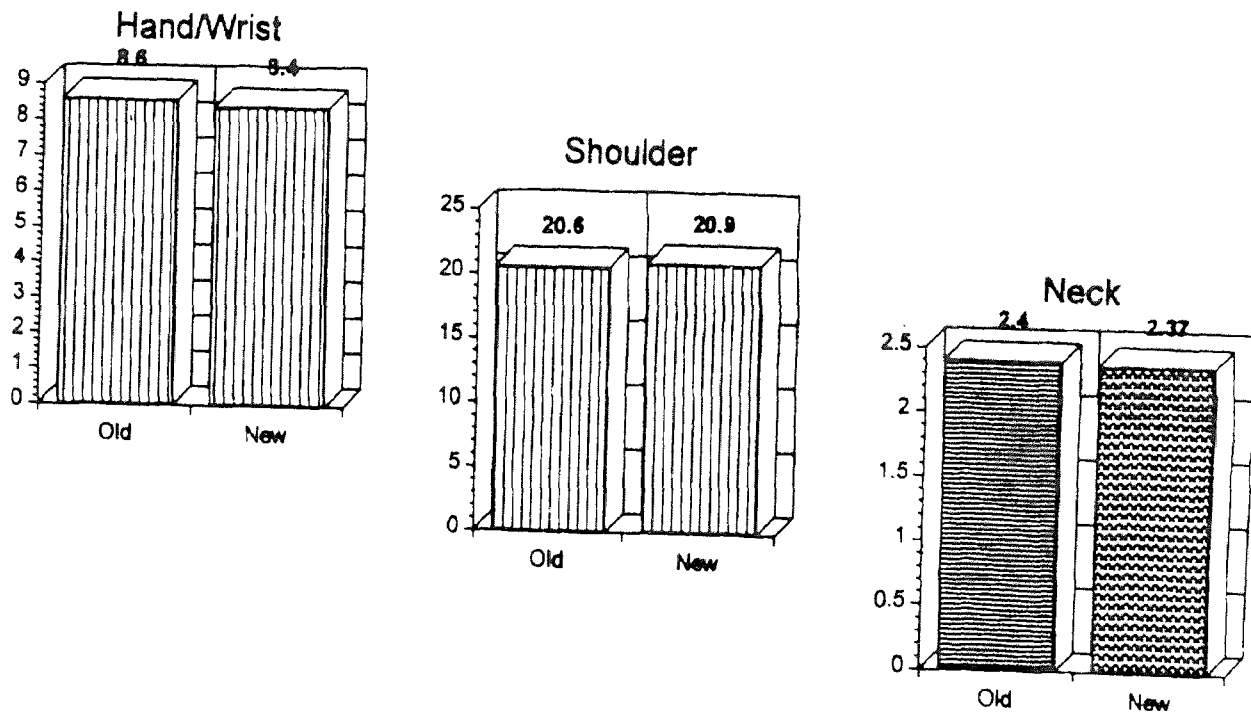
ELBOW			WRIST			HAND			FINGER		
RNG	FREQ	%	RNG	FREQ	%	RNG	FREQ	%	RNG	FREQ	%
4	8	80	4	8	80	4	8	80	4	9	90
8	2	20	8	1	10	8	2	20	8	0	0
12	0	0	12	1	10	12	0	0	12	1	10
16	0	0	16	0	0	16	0	0	16	0	0
4	9	90	4	8	80	4	8	80	4	9	90
8	1	10	8	1	10	8	2	20	8	0	0
12	0	0	12	1	10	12	0	0	12	1	10
16	0	0	16	0	0	16	0	0	16	0	0

ELBOW			WRIST			HAND			FINGER		
RNG	FREQ	%	RNG	FREQ	%	RNG	FREQ	%	RNG	FREQ	%
4	10	100	4	8	80	4	9	90	4	10	100
8	0	0	8	1	10	8	1	10	8	0	0
12	0	0	12	1	10	12	0	0	12	0	0
16	0	0	16	0	0	16	0	0	16	0	0
4	10	100	4	8	80	4	9	90	4		0
8	0	0	8	1	10	8	1	10	8		0
12	0	0	12	1	10	12	0	0	12		0
16	0	0	16	0	0	16	0	0	16		0

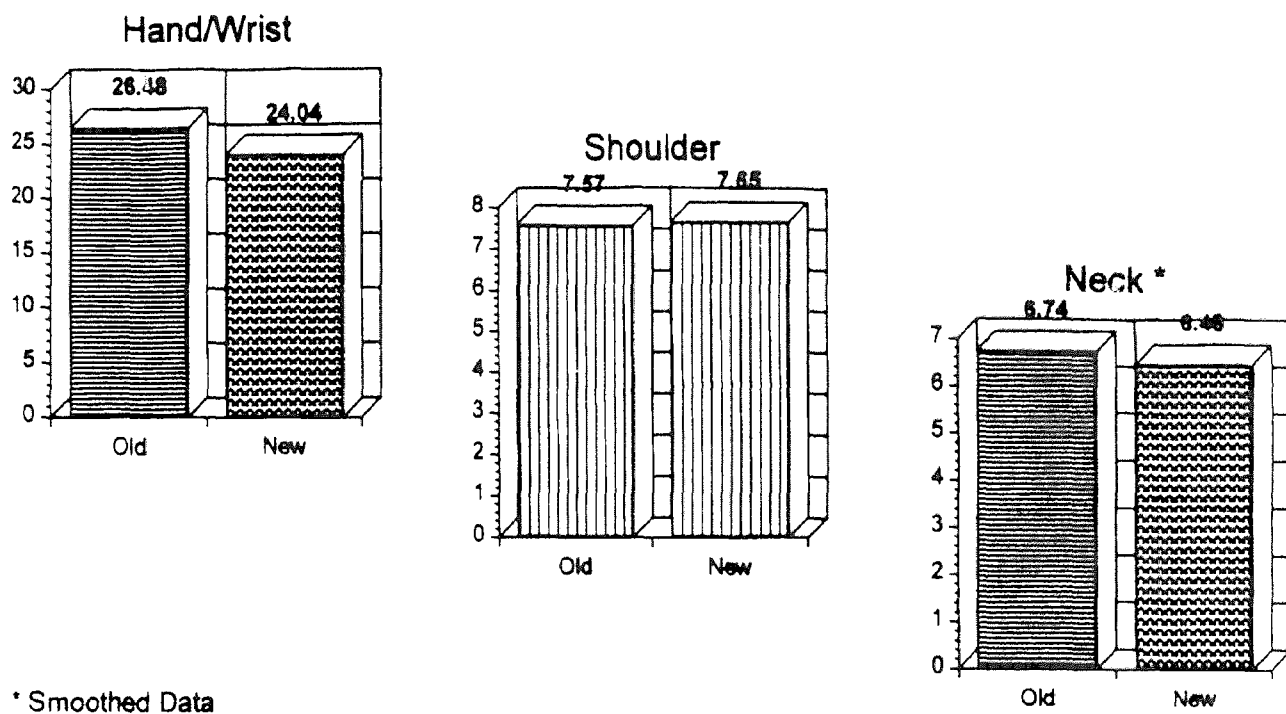
# **Appendix D**

## **Examples of General Linear Model Results**

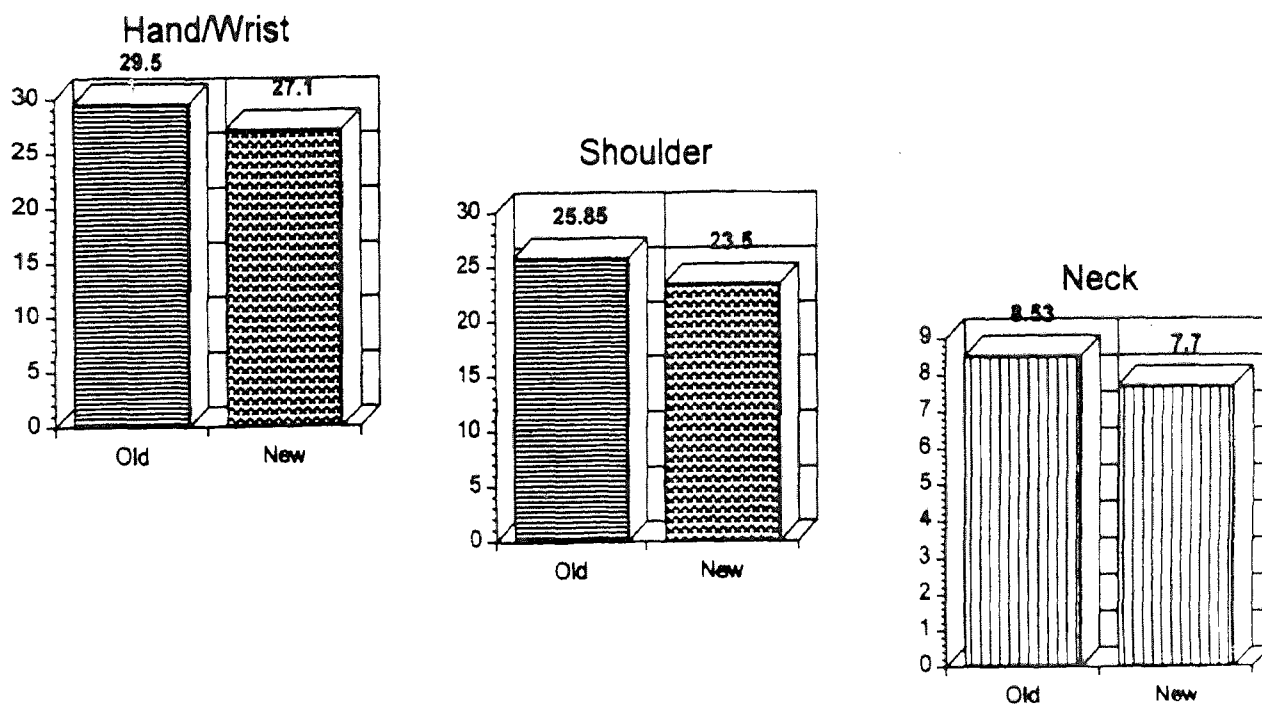
### **ANOVAs and Means Tests**



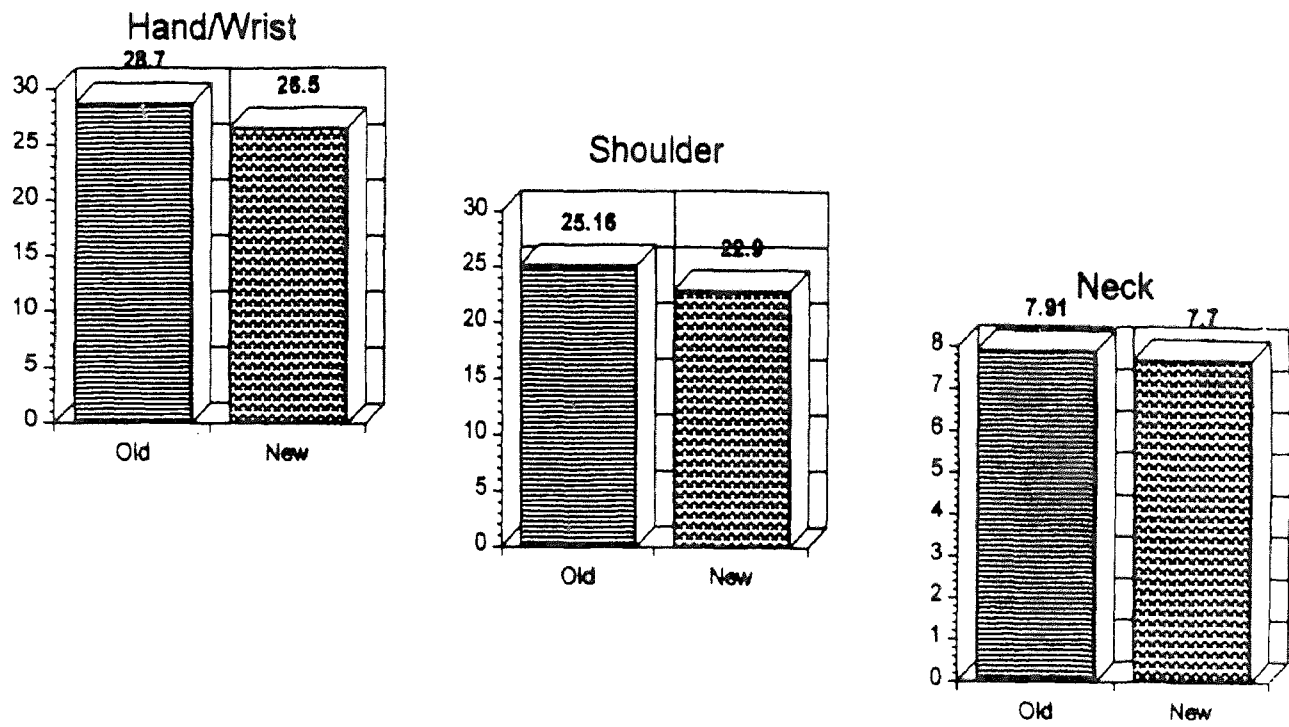
**Figure 19** - EMG results (based on raw data) for subject 2. Statistical significance is indicated by bar type.



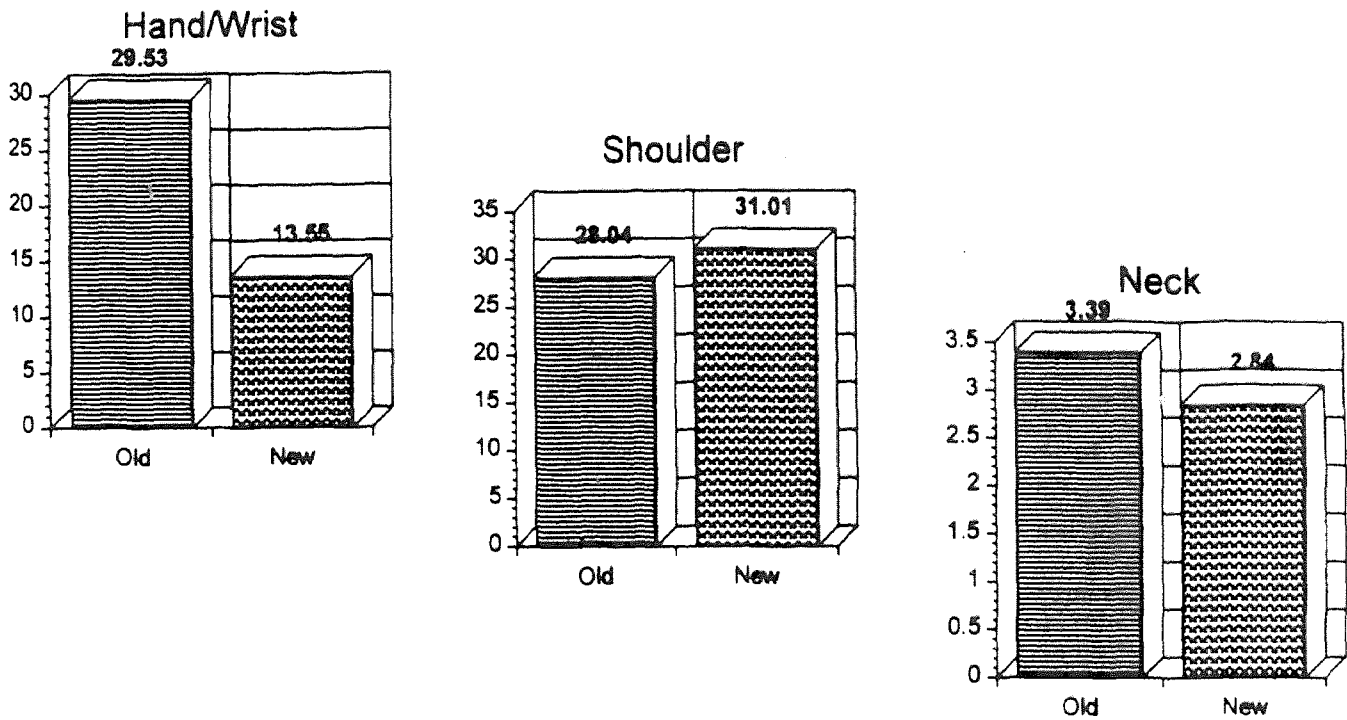
**Figure 20** - EMG results (based on raw data) for subject 4. Statistical significance is indicated by bar type.



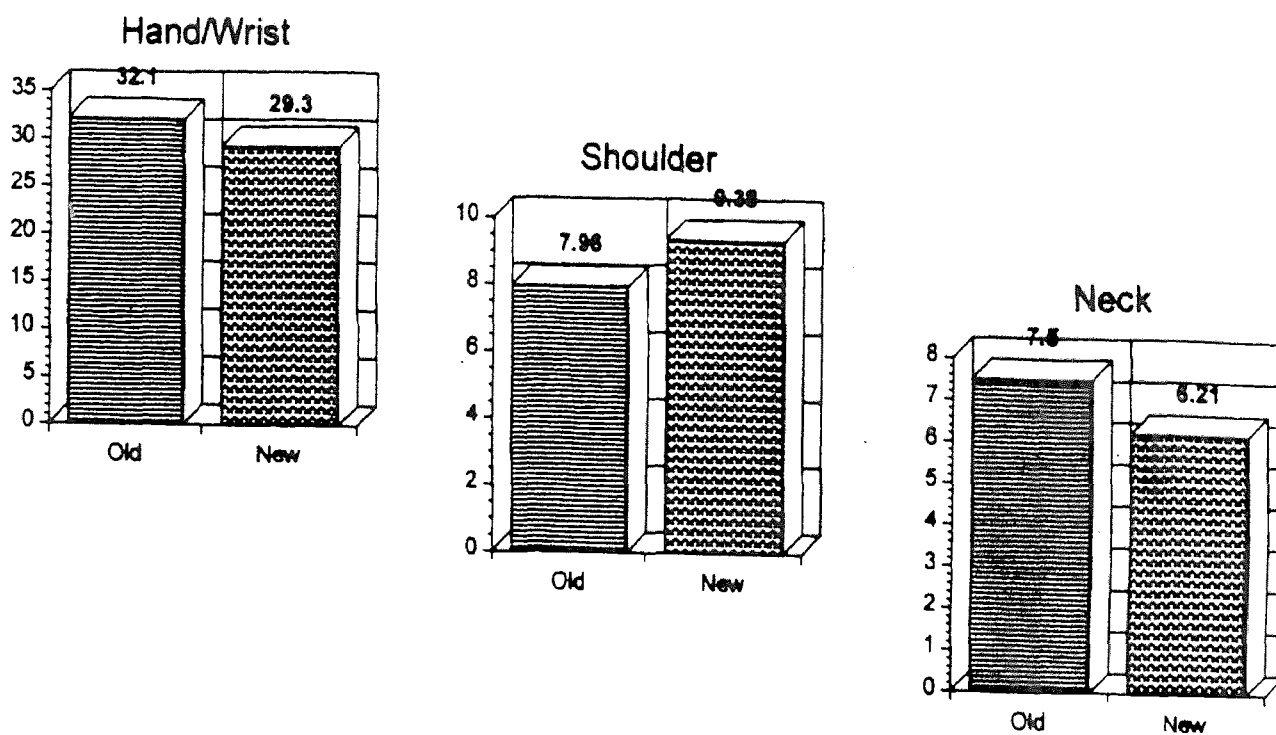
**Figure 21** - EMG results (based on raw data) for subject 5. Significant improvement for both hand/wrist and shoulder muscles is identified.



**Figure 22** - EMG results (based on smoothed data) for subject 5. Significant improvement is revealed for all three muscle groups.

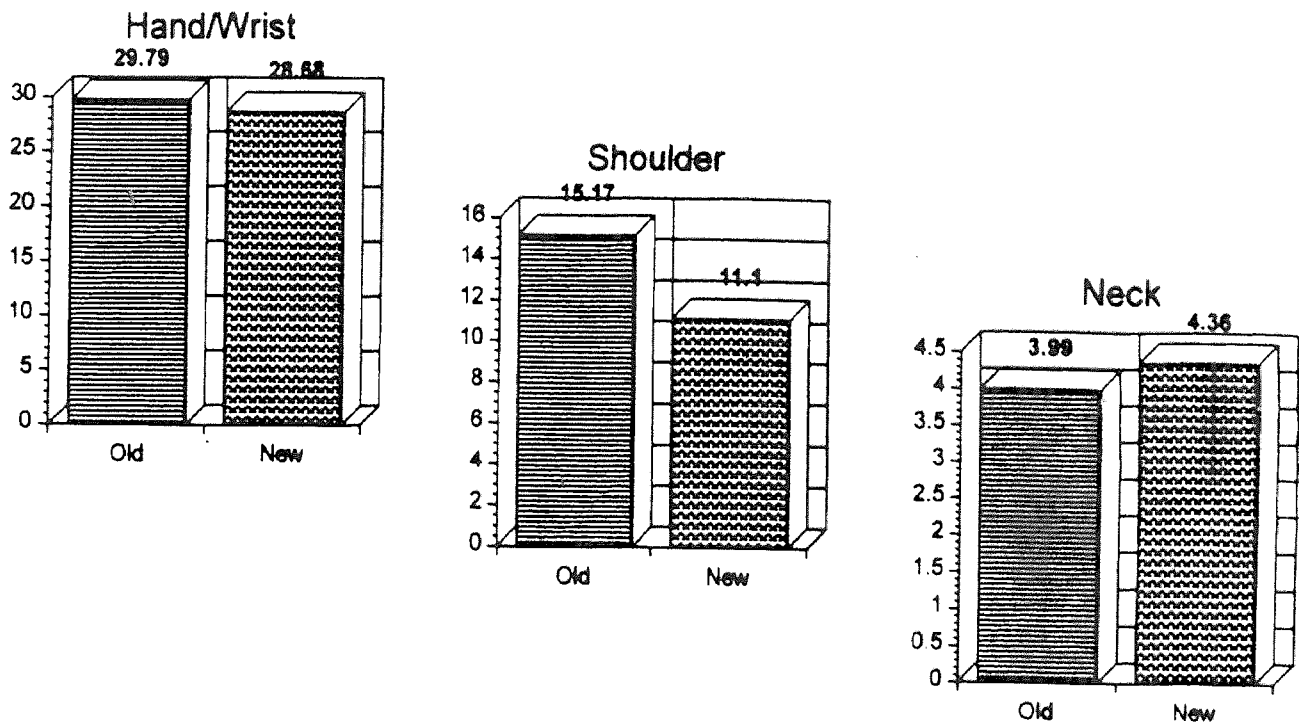


**Figure 23** - EMG results (based on raw data) for subject 6. Dramatic improvement for the hand/wrist is revealed, but a significant increase in shoulder muscle activity is found. Upper trapezius muscle activity also significantly decreased.

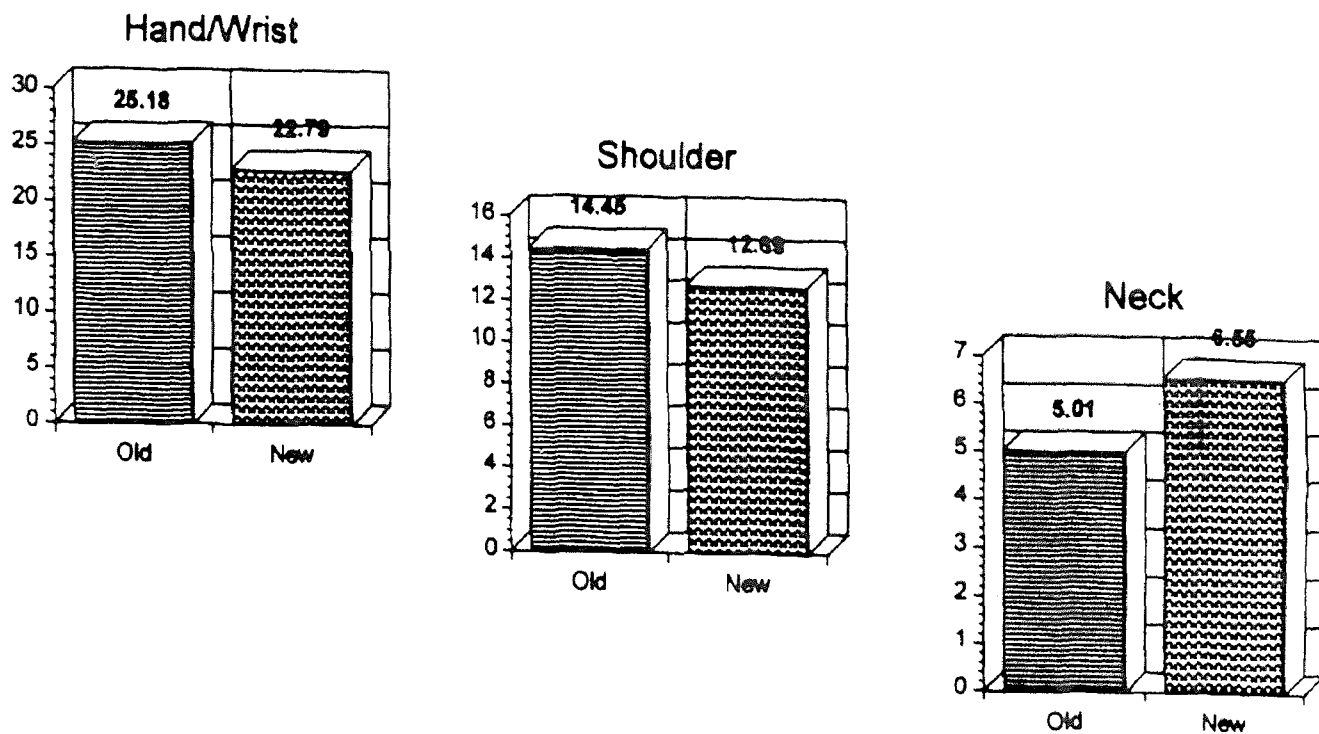


**Figure 24** - EMG results (based on raw data) for subject 7. Results were mixed, with improvements to two of three muscle groups, but an increase for shoulders.

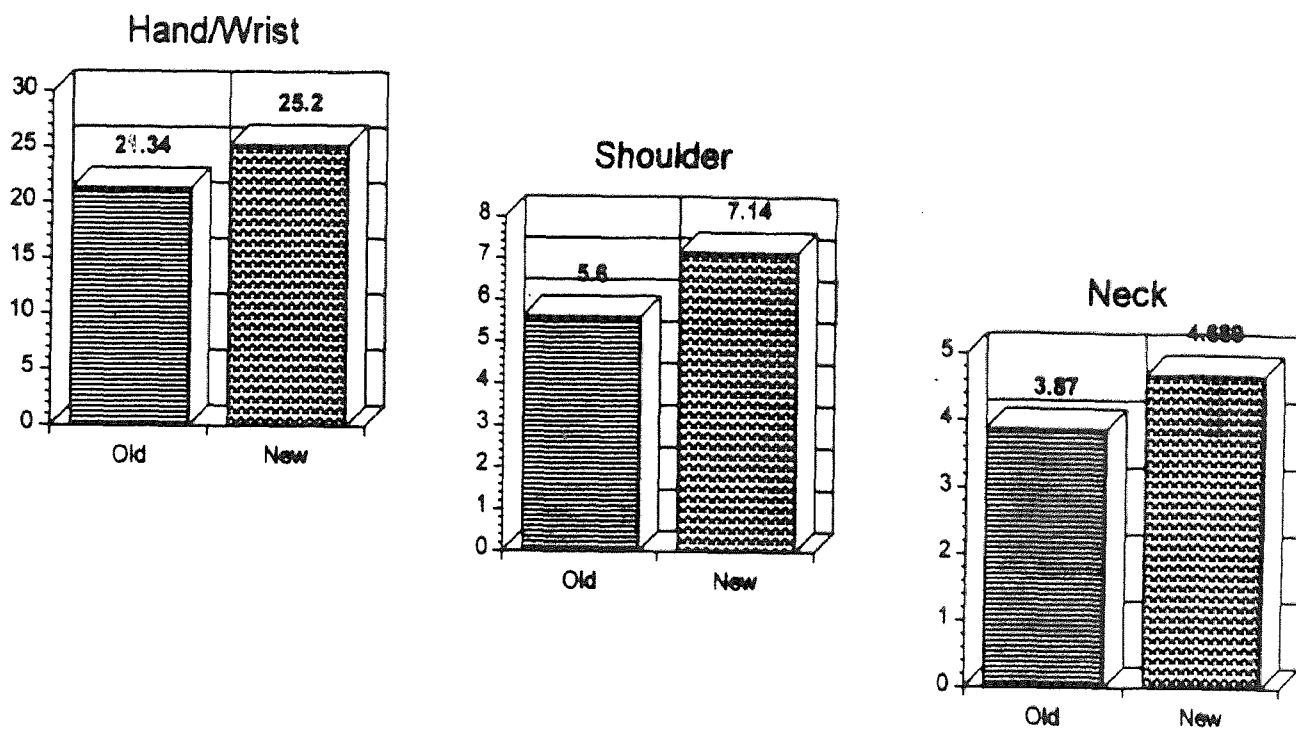




**Figure 25** - EMG results (based on raw data) for subject 8. Results were mixed, with improvements to two of three muscle groups, but an increase for neck muscles.



**Figure 26** - EMG results (based on raw data) for subject 9. Results were mixed, with improvements to two of three muscle groups, but an increase for neck muscles.



**Figure 27** - EMG results (based on raw data) for subject 10. Results indicated significant detriments to all three muscle groups. This subject was found to be struggling with the new controls, due in part to differing control activation sensitivity and to inadequate learning time prior to data collections.

**The SAS System General Linear Models Procedure**

Source	DF	Type I SS	Mean Square	F Value	Pr > F
WORKST	1	14.451262	14.451262	2.06	0.1520
SUBJ	8	593.665234	7421.583154	1055.85	0.0001
WORST*SUBJ	8	905.824294	113.228037	16.11	0.0001

Dependent Variable: OBS

Source	DF	Type II SS	Mean Square	F Value	Pr > F
WORKST	1	6.524853	6.524853	0.93	0.1520
SUBJ	8	59372.665234	7421.583154	1055.85	0.0001
WORST*SUBJ	8	905.824294	113.228037	16.11	0.0001

Source	DF	Type III SS	Mean Square	F Value	Pr > F
WORKST	1	11.096077	11.096077	1.58	0.1520
SUBJ	8	59630.705078	7453.838135	1060.44	0.0001
WORST*SUBJ	8	905.824294	113.228037	16.11	0.0001

Source	DF	Type IV SS	Mean Square	F Value	Pr > F
WORKST	1	11.096077	11.096077	1.58	0.1520
SUBJ	8	59630.705078	7453.838135	1060.44	0.0001
WORST*SUBJ	8	905.824294	113.228037	16.11	0.0001

**Table 6** - ANOVA results for the shoulder based on raw data. No significant difference is revealed for the workstation effect.

Means With The Same Letter Are Not Significantly Different.

Duncan Grouping	Mean	N	WORKST
A	13.9352	455	100.0
A			
A	13.6859	476	200.

**Table 7** - Means tests confirms non-significance at the .05 level for the shoulders, based on raw data.

### The SAS System General Linear Models Procedure

Source	DF	Type I SS	Mean Square	F Value	Pr > F
WORKST	1	323.348994	323.348994	79.07	0.0001
SUBJ	8	48194.156494	6024.269562	1473.07	0.0001
WORST*SUBJ	8	2347.843174	293.480397	71.76	0.0001

Dependent Variable: OBS

Source	DF	Type II SS	Mean Square	F Value	Pr > F
WORKST	1	286.267017	286.267017	70.00	0.0001
SUBJ	8	48194.156494	6024.269562	1473.07	0.0001
WORST*SUBJ	8	2347.843174	293.480397	71.76	0.0001

Source	DF	Type III SS	Mean Square	F Value	Pr > F
WORKST	1	282.314486	282.314486	69.03	0.0001
SUBJ	8	48395.400992	6049.425124	1479.22	0.0001
WORST*SUBJ	8	2347.843174	293.480397	71.76	0.0001

Source	DF	Type IV SS	Mean Square	F Value	Pr > F
WORKST	1	282.314486	282.314486	69.03	0.0001
SUBJ	8	48395.400992	6049.425124	1479.22	0.0001
WORST*SUBJ	8	2347.843174	293.480397	71.76	0.0001

**Table 8** - ANOVA results for the shoulder based on smoothed data. Smoothing the data allowed a significant workstation effect to be clearly revealed.

Means With The Same Letter Are Not Significantly Different.

Duncan Grouping	Mean	N	WORKST
A	14.7851	455	100.0
B	13.6062	476	200.

**Table 9** - Means tests for the shoulder based on smoothed data reveal the effect was improvement (significantly decreased muscle activity).

**The SAS System General Linear Models Procedure**

Source	DF	Type I SS	Mean Square	F Value	Pr > F
WORKST	1	7.8454024	7.8454024	10.93	0.0010
SUBJ	8	3315.6053226	414.4506653	577.28	0.0001
WORST*SUBJ	8	180.6358290	22.5794786	31.45	0.0001

Dependent Variable: OBS

Source	DF	Type II SS	Mean Square	F Value	Pr > F
WORKST	1	6.4536403	6.4536403	8.99	0.0028
SUBJ	8	3315.6053226	414.4506653	577.28	0.0001
WORST*SUBJ	8	180.6358290	22.5794786	31.45	0.0001

Source	DF	Type III SS	Mean Square	F Value	Pr > F
WORKST	1	5.1713396	5.1713396	7.20	0.0074
SUBJ	8	3340.4045257	417.5505657	581.59	0.0001
WORST*SUBJ	8	180.6358290	22.5794786	31.45	0.0001

Source	DF	Type IV SS	Mean Square	F Value	Pr > F
WORKST	1	5.1713396	5.1713396	7.20	0.0074
SUBJ	8	3340.4045257	417.5505657	581.59	0.0001
WORST*SUBJ	8	180.6358290	22.5794786	31.45	0.0001

**Table 10** - ANOVA results for the upper trapezius based on raw data. The workstation effect was significant. These results include data for problematic subject #10.



### The SAS System General Linear Models Procedure

Source	DF	Type I SS	Mean Square	F Value	Pr > F
WORKST	1	4.2038025	4.2038025	5.27	0.0220
SUBJ	7	3155.0125380	450.7160769	564.85	0.0001
WORST*SUBJ	7	166.8711725	23.8387389	29.88	0.0001

Dependent Variable: OBS

Source	DF	Type II SS	Mean Square	F Value	Pr > F
WORKST	1	1.0540947	1.0540947	1.32	0.2508
SUBJ	7	3155.0125380	450.7160769	564.85	0.0001
WORST*SUBJ	7	166.8711725	23.8387389	29.88	0.0001

Source	DF	Type III SS	Mean Square	F Value	Pr > F
WORKST	1	0.9692291	0.9692291	1.21	0.2707
SUBJ	7	3166.2529775	452.3218539	566.86	0.0001
WORST*SUBJ	7	166.8711725	23.8387389	29.88	0.0001

Source	DF	Type IV SS	Mean Square	F Value	Pr > F
WORKST	1	0.9692291	0.9692291	1.21	0.2707
SUBJ	7	3166.2529775	452.3218539	566.86	0.0001
WORST*SUBJ	7	166.8711725	23.8387389	29.88	0.0001

**Table 11** - ANOVA results for the upper trapezius *excluding* data from problematic subject #10. Significance on the workstation effect is revealed for only one of four types of SS ANOVAs. The results indicate a marginal, possibly non-significant effect.

Missing Page

Missing Page

Missing Page

R-Square	C.V	Root MSE	OBS Mean
0.882823	11.94932	2.5971048	21.734329

Source	DF	Type I SS	Mean Square	F Value	Pr > F
WORKST	1	329.613496	329.613496	48.87	0.0001
SUBJ	8	43419.650571	5427.456321	804.67	0.0001
WORKST*SUBJ	8	2646.572257	330.821532	49.05	0.0001

The SAS System 17:00 Friday, March 4, 1994 25

#### General Linear Models Procedure

Dependent Variable: OBS

Source	DF	Type II SS	Mean Square	F Value	Pr > F
WORKST	1	351.365335	351.365335	52.09	0.0001
SUBJ	8	43419.650571	5427.456321	804.67	0.0001
WORKST*SUBJ	8	2646.572257	330.821532	49.05	0.0001

Source	DF	Type III SS	Mean Square	F Value	Pr > F
WORKST	1	519.657529	519.657529	77.04	0.0001
SUBJ	8	43350.724518	5418.840565	803.39	0.0001
WORKST*SUBJ	8	2646.572257	330.821532	49.05	0.0001

Source	DF	Type IV SS	Mean Square	F Value	Pr > F
WORKST	1	519.657529	519.657529	77.04	0.0001
SUBJ	8	43350.724518	5418.840565	803.39	0.0001
WORKST*SUBJ	8	2646.572257	330.821532	49.05	0.0001

The SAS System 17:00 Friday, March 4, 1994 26

#### General Linear Models Procedure

Duncan's Multiple Range Test for variable: OBS

NOTE: This test controls the type I comparisonwise error rate, not the experimentwise error rate.

Alpha= 0.05 df= 913 MSE= 6.744933  
 WARNING: Cell sizes are not equal.  
 Harmonic Mean of cell sizes= 465.2159

Number of Means 2  
 Critical Range .3383

Means with the same letter are not significantly different.

Duncan Grouping	Mean	N	WORKST
A	22.3442	454	100.0
B	21.1538	477	200.

The SAS System 17:00 Friday, March 4, 1994 27

General Linear Models Procedure

Student-Newman-Keuls test for variable: OBS

NOTE: This test controls the type I experimentwise error rate under the complete null hypothesis but not under partial null hypotheses.

Alpha= 0.05 df= 913 MSE= 6.744953  
 WARNING: Cell sizes are not equal.  
 Harmonic Mean of cell sizes= 465.2159

Number of Means 2  
 Critical Range 0.3341962

Means with the same letter are not significantly different.

SNK Grouping	Mean	N	WORKST
A	22.3442	454	100.0
B	21.1538	477	200.

The SAS System 17:00 Friday, March 4, 1994 28

General Linear Models Procedure

Tukey's Studentized Range (HSD) Test for variable: OBS

NOTE: This test controls the type I experimentwise error rate, but generally has a higher type II error rate than REGWQ.

Alpha= 0.05 df= 913 MSE= 6.744953  
 Critical Value of Studentized Range= 2.775  
 Minimum Significant Difference= 0.3342  
 WARNING: Cell sizes are not equal.  
 Harmonic Mean of cell sizes= 465.2159

Means with the same letter are not significantly different.

Tukey Grouping	Mean	N	WORKST
A	22.3442	454	100.0
B	21.1538	477	200.

The SAS System 17:00 Friday, March 4, 1994 29

General Linear Models Procedure

Studentized Maximum Modulus (GT2) Test for variable: OBS

NOTE: This test controls the type I experimentwise error rate, but generally has a higher type II error rate than REGWQ.

Alpha= 0.05 df= 913 MSE= 6.744953  
 Critical Value of Studentized Maximum Modulus= 1.963  
 Minimum Significant Difference= 0.3342  
 WARNING: Cell sizes are not equal.  
 Harmonic Mean of cell sizes= 465.2159

The SAS System 17:00 Friday, March 4, 1994 30

General Linear Models Procedure

Scheffe's test for variable: OBS

NOTE: This test controls the type I experimentwise error rate but generally has a higher type II error rate than REGWF for all pairwise comparisons

Alpha= 0.05 df= 913 MSE= 6.744953  
 Critical Value of F= 3.85166  
 Minimum Significant Difference= 0.3342  
 WARNING: Cell sizes are not equal.  
 Harmonic Mean of cell sizes= 465.2159

Means with the same letter are not significantly different.

Scheffe Grouping	Mean	N	WORKST
A	22.3442	454	100.0
B	21.1538	477	200

The SAS System 17:00 Friday, March 4, 1994 31

General Linear Models Procedure

Duncan's Multiple Range Test for variable: OBS

NOTE: This test controls the type I comparisonwise error rate, not the experimentwise error rate

Alpha= 0.05 df= 913 MSE= 6.744953  
 WARNING: Cell sizes are not equal.  
 Harmonic Mean of cell sizes= 102.1343

Number of Means 2 3 4 5 6 7 8 9  
 Critical Range .7220 .7592 .7831 .8011 .8163 .8287 .8388 .8472

Means with the same letter are not significantly different.

Duncan Grouping	Mean	N	SUBJ
A	30.3559	107	7
B	27.4839	93	5.
B	27.0541	98	8.

## General Linear Models Procedure

Duncan Grouping	Mean	N	SUBJ
C	25.0167	104	4.
D	23.5370	94	9.
D	23.2500	124	10.
E	17.8266	85	6.
F	14.6576	108	1.0
G	8.3371	118	2.

The SAS System 17:00 Friday, March 4, 1994 33

## General Linear Models Procedure

Student-Newman-Keuls test for variable: OBS

NOTE: This test controls the type I experimentwise error rate under the complete null hypothesis but not under partial null hypotheses.

Alpha= 0.05 df= 913 MSE= 6.744953

WARNING: Cell sizes are not equal.

Harmonic Mean of cell sizes= 102.1343

Number of Means	2	3	4	5
Critical Range	0.7132521	0.8531617	0.9353815	0.9933363

Number of Means	6	7	8	9
Critical Range	1.0378714	1.0739034	1.1040783	1.1299816

Means with the same letter are not significantly different.

The SAS System 17:00 Friday, March 4, 1994 34

## General Linear Models Procedure

SNK Grouping	Mean	N	SUBJ
A	30.3559	107	7.
B	27.4839	93	5.
B	27.0541	98	8.
C	25.0167	104	4.
D	23.5370	94	9.
D	23.2500	124	10.
E	17.8266	85	6.
F	14.6576	108	1.0
G	8.3371	118	2.



The SAS System 17:00 Friday, March 4, 1994 35

General Linear Models Procedure

Tukey's Studentized Range (HSD) Test for variable: OBS

NOTE: This test controls the type I experimentwise error rate, but generally has a higher type II error rate than REGWQ.

Alpha= 0.05 df= 913 MSE= 6.744953  
 Critical Value of Studentized Range= 4.397  
 Minimum Significant Difference= 1.13  
 WARNING: Cell sizes are not equal.  
 Harmonic Mean of cell sizes= 102.1343

Means with the same letter are not significantly different.

Tukey Grouping	Mean	N	SUBJ
A	30.3559	107	7
B	27.4839	93	5
B	27.0541	98	8
C	25.0167	104	4

The SAS System 17:00 Friday, March 4, 1994 36

General Linear Models Procedure

Tukey Grouping	Mean	N	SUBJ
D	23.5370	94	9
D	23.2500	124	10
E	17.8266	85	6
F	14.6576	108	10
G	8.3371	118	2

The SAS System 17:00 Friday, March 4, 1994 37

General Linear Models Procedure

Studentized Maximum Modulus (GT2) Test for variable: OBS

NOTE: This test controls the type I experimentwise error rate, but generally has a higher type II error rate than REGWQ.

Alpha= 0.05 df= 913 MSE= 6.744953  
 Critical Value of Studentized Maximum Modulus= 3.199  
 Minimum Significant Difference= 1.1626  
 WARNING: Cell sizes are not equal.  
 Harmonic Mean of cell sizes= 102.1343

Means with the same letter are not significantly different.

SMM Grouping	Mean	N	SUBJ
A	30.3559	107	7.
B	27.4839	93	5.
B	27.0541	98	8.
C	25.0167	104	4.

The SAS System 17:00 Friday, March 4, 1994 38

General Linear Models Procedure

SMM Grouping	Mean	N	SUBJ
D	23.5370	94	9.
D	23.2500	124	10.
E	17.8266	85	6.
F	14.6576	108	1.0
G	8.3371	118	2.

The SAS System 17:00 Friday, March 4, 1994 39

General Linear Models Procedure

Scheffe's test for variable: OBS

NOTE: This test controls the type I experimentwise error rate but generally has a higher type II error rate than REGWF for all pairwise comparisons

Alpha= 0.05 df= 913 MSE= 6.744953  
 Critical Value of F= 1.94853  
 Minimum Significant Difference= 1.4349  
 WARNING: Cell sizes are not equal.  
 Harmonic Mean of cell sizes= 102.1343

Means with the same letter are not significantly different.

Scheffe Grouping	Mean	N	SUBJ
A	30.3559	107	7.
B	27.4839	93	5.
B	27.0541	98	8.

The SAS System 17:00 Friday, March 4, 1994 40

## General Linear Models Procedure

Scheffe Grouping	Mean	N	SUBJ
C	25.0167	104	4.
D	23.5370	94	9.
D	23.2500	124	10.
E	17.8266	85	6.
F	14.6576	108	1.0
G	8.3371	118	2.

Level of WORKST	Level of SUBJ	-----OBS-----		
		N	Mean	SD
100.0	1.0	52	14.7923077	1.96073677
100.0	10.	52	20.8965385	2.36465716

The SAS System 17:00 Friday, March 4, 1994 41

## General Linear Models Procedure

Level of WORKST	Level of SUBJ	-----OBS-----		
		N	Mean	SD
100.0	2.	57	8.4385965	0.91313322
100.0	4.	54	25.9211111	2.42709055
100.0	5.	40	28.7130000	4.15068125
100.0	6.	44	22.2040909	2.56581309
100.0	7.	53	32.1000000	3.62512599
100.0	8.	48	26.0858333	2.86439614
100.0	9.	54	24.6074074	2.41238720
200.	1.0	56	14.5325000	1.78949079
200.	10.	72	24.9497222	2.42218384
200.	2.	61	8.2422951	0.79605777
200.	4.	50	24.0400000	3.06101224
200.	5.	53	26.5562264	3.98943809
200.	6.	41	13.1287805	1.88116479
200.	7.	54	28.6440741	2.50428879
200.	8.	50	27.9836000	2.71680692
200.	9.	40	22.0920000	2.44186478

# Appendix E

## Workstation Details

CURRENT WORKSTATION  
SIDE VIEW

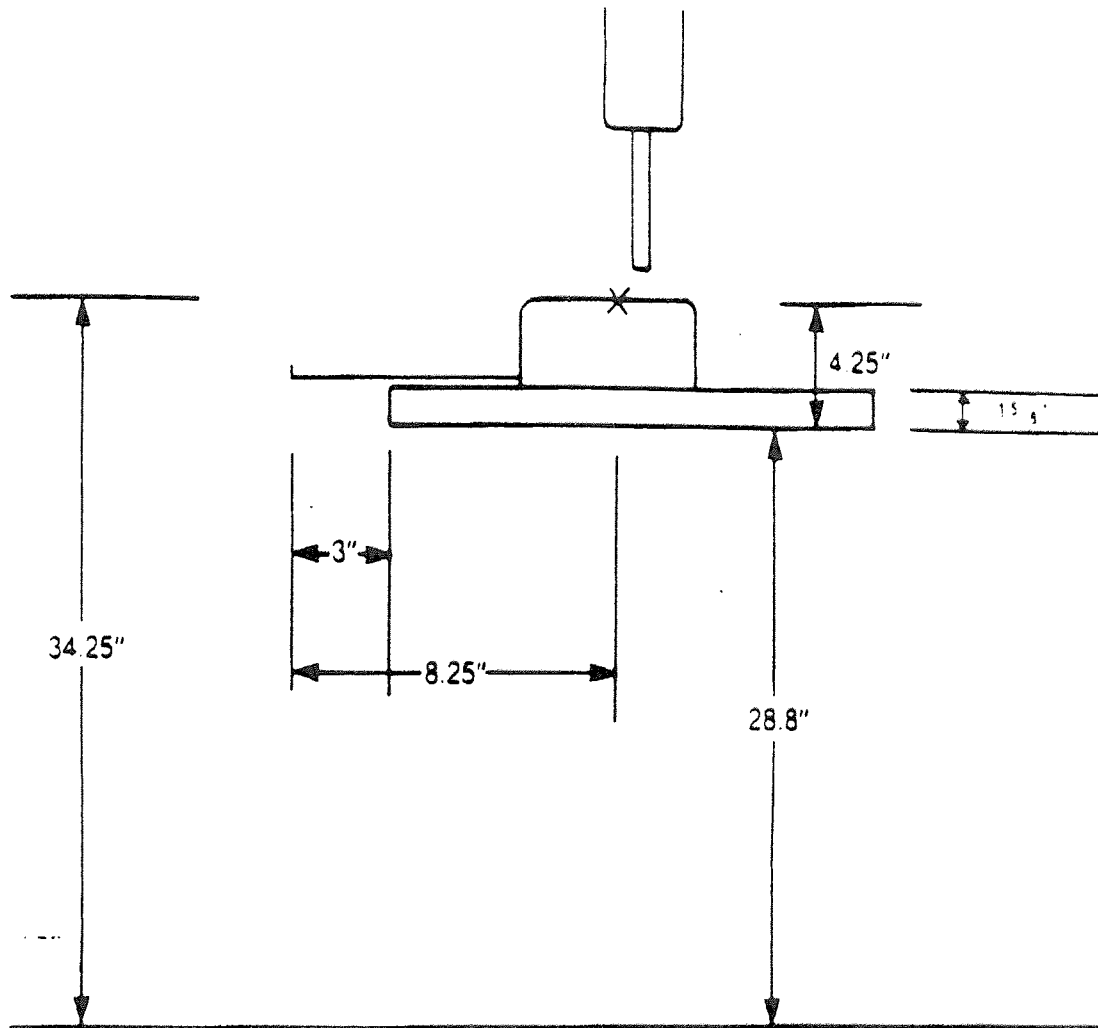
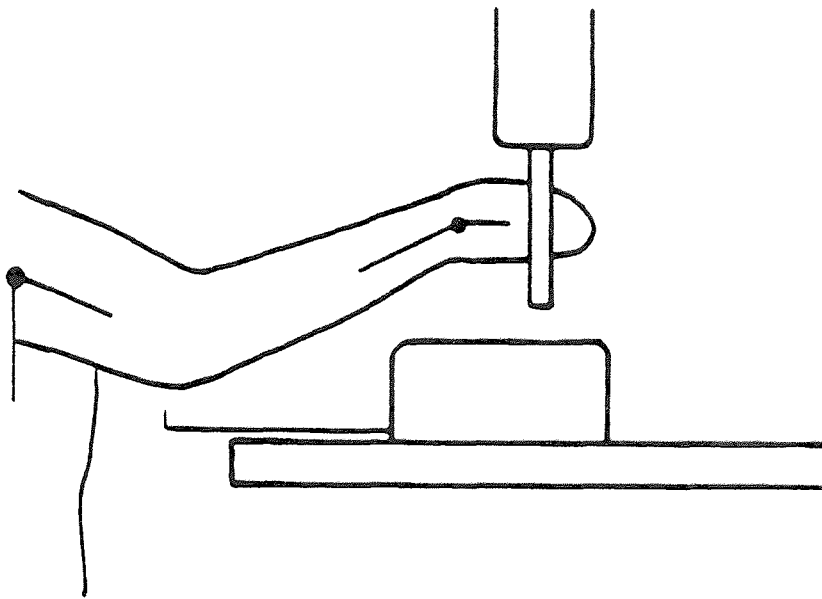


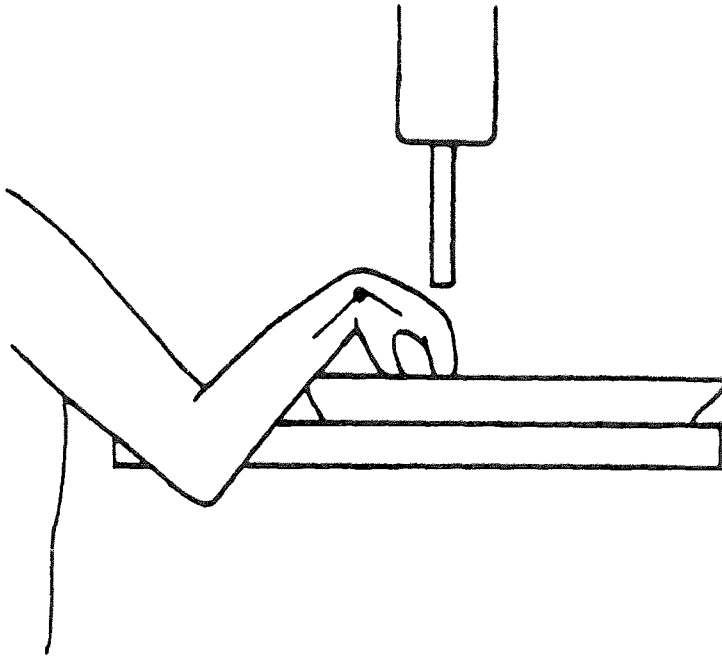
Figure E-1 The old workstation prior to any changes.

## SHOULDER FLEXION



**CURRENT SITUATION: SHOULDERS ARE STATICALLY LOADED AND WRISTS FREQUENTLY DEVIATED**

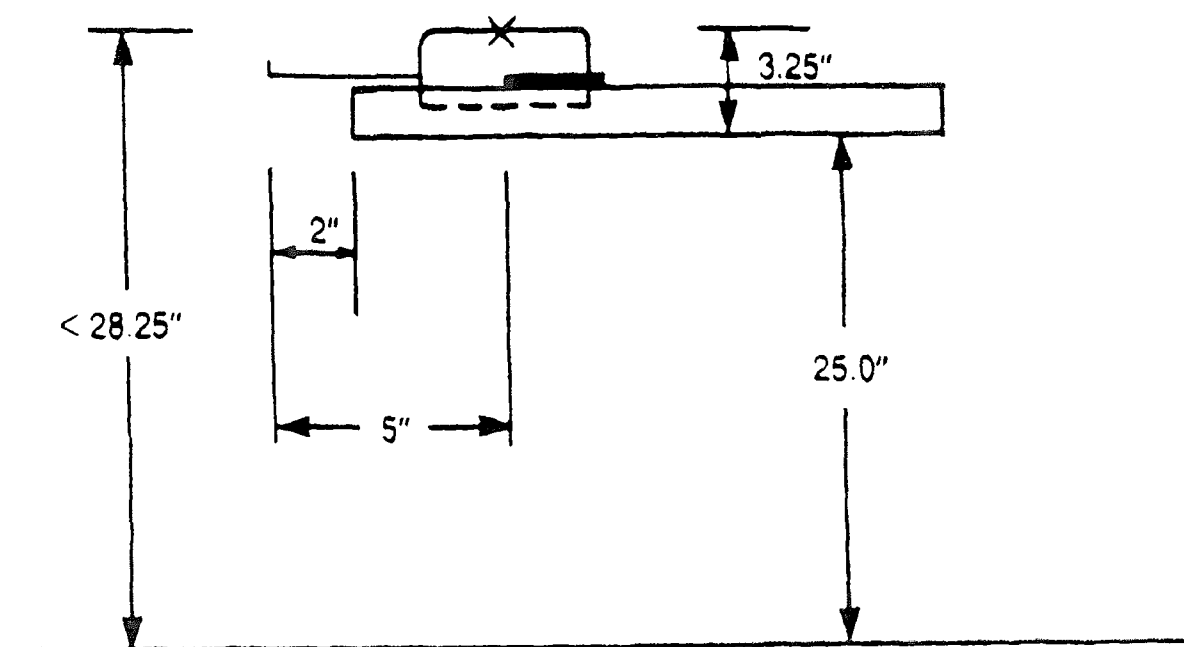
**Figure E-2** The shoulders are repeatedly flexed and statically loaded during control activation at the old workstation.

**WRIST FLEXION**

**CURRENT SITUATION: GRASPING PARTS INDUCES WRIST FLEXION**

**Figure E-3** The wrists are repeatedly flexed at the old workstation.

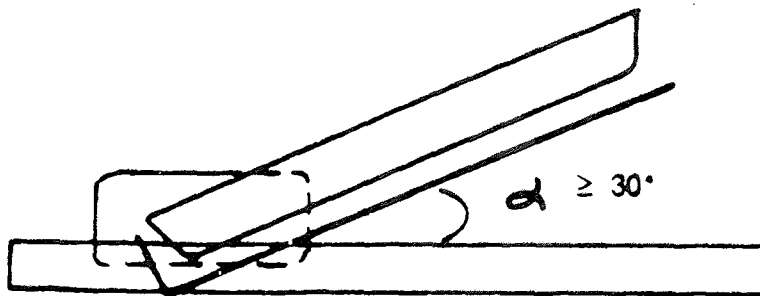
**PROPOSED WORKSTATION  
SIDE VIEW**



**Figure E-4** A proposal for reducing the height of workstation, and the relative distance from fixture height to table top, compared to the old (existing) workstation.

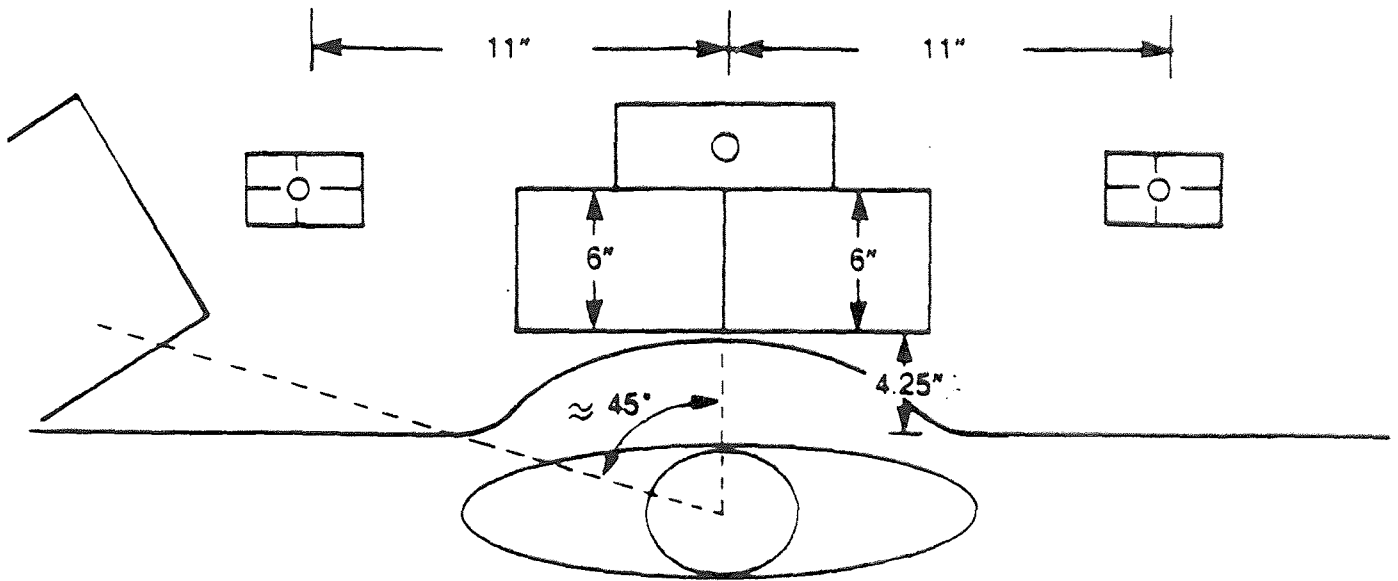


PROPOSED WORKSTATION  
SIDE VIEW



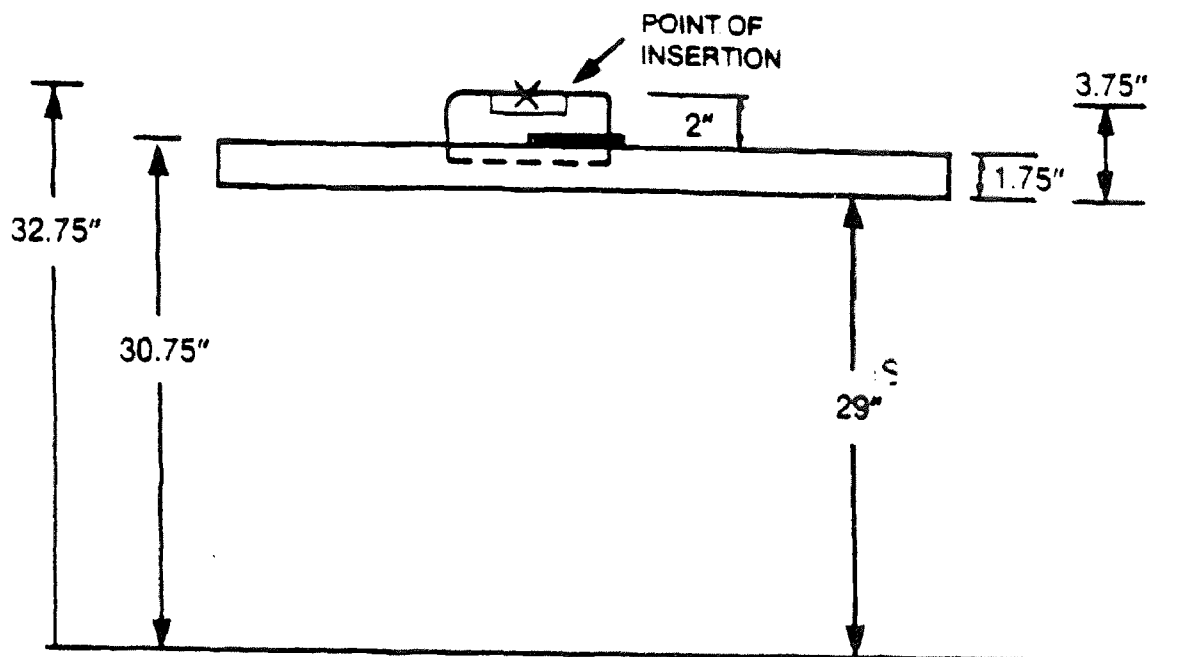
**Figure E-5** It was suggested that parts trays be positioned at an angle to help reduce reaching and improve posture.

ACTUAL PROTOTYPE DIMENSIONS  
TOP VIEW

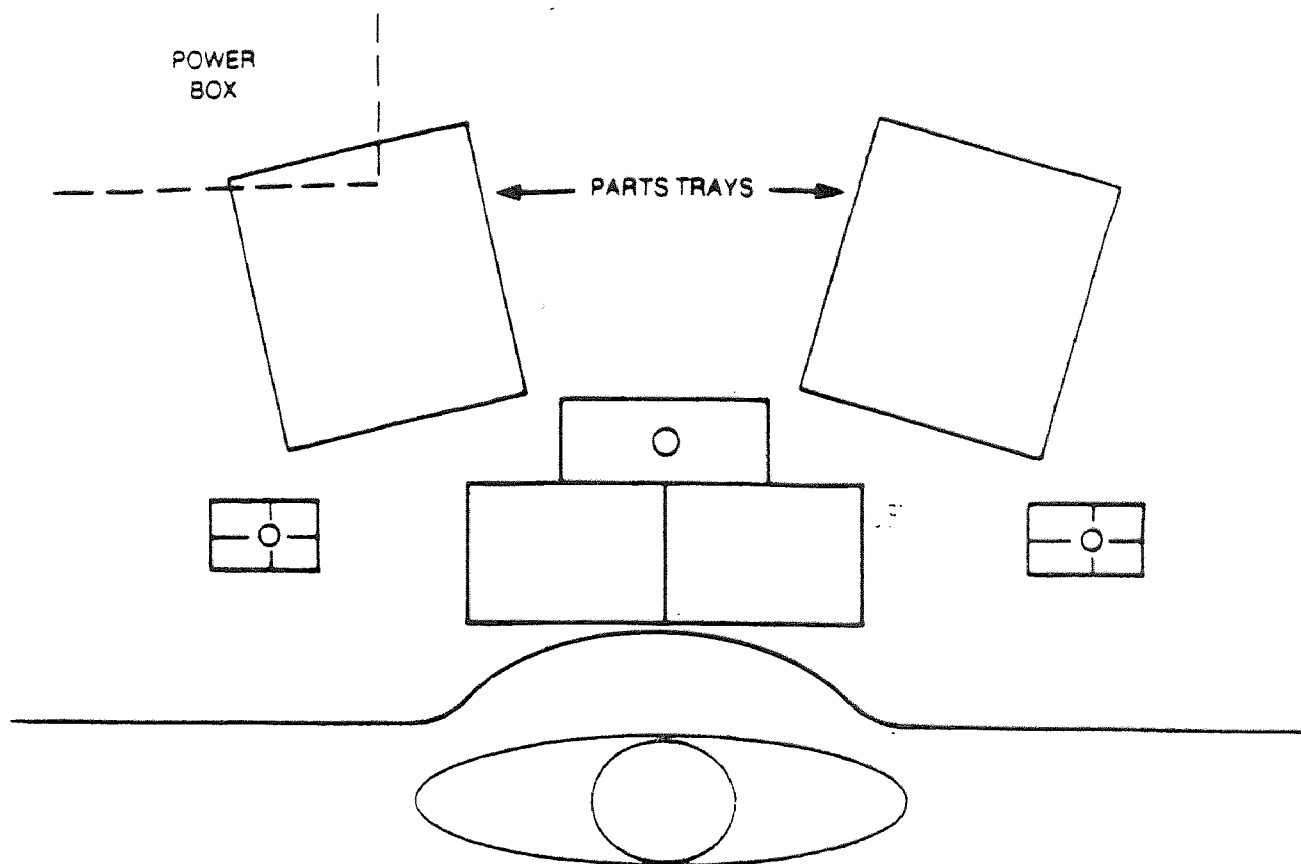


**Figure E-6** The dimensions of the prototype did not match the proposed dimensions due to some practical limitations.

ACTUAL PROTOTYPE DIMENSIONS  
SIDE VIEW



**Figure E-7** Changes to the workstation heights were not nearly as dramatic as has been proposed, due to practical limitations in developing the prototype.

**FURTHER SUGGESTED ENHANCEMENTS****TOP VIEW**

**Figure E-8** Suggestions for further improvements to the workstation layout were offered.

FURTHER SUGGESTED ENHANCEMENTS  
SIDE VIEW

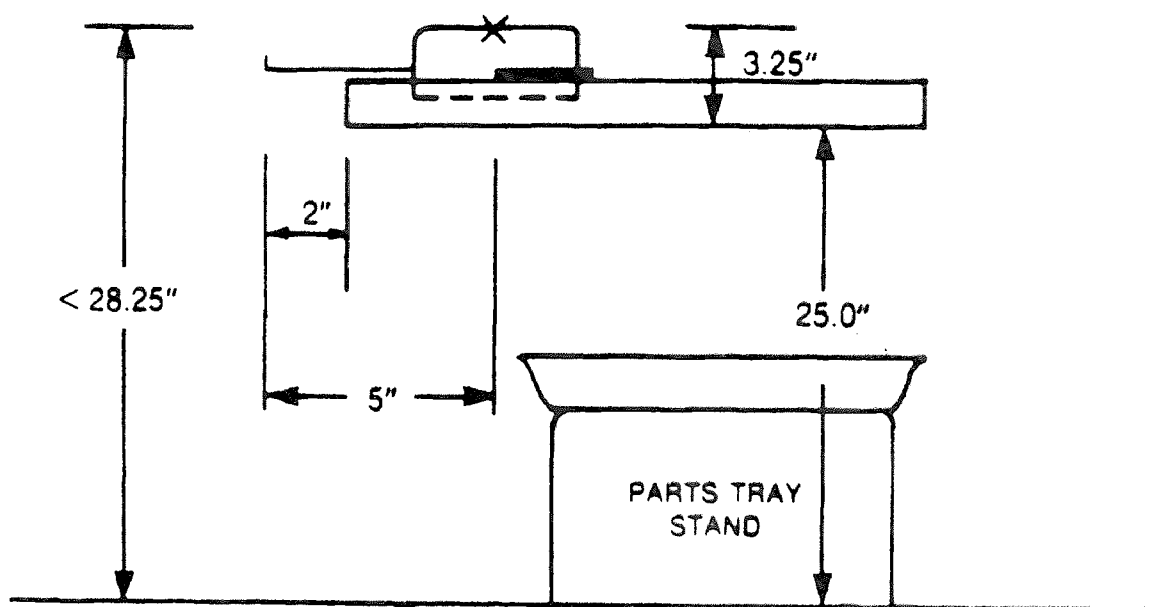


Figure E-9 A parts tray stand was suggested which could be set directly on the floor.

# Appendix F

## Posture Results

	<u>Sub 2 - Old</u>	<u>Sub 2 - New</u>	<u>Z</u>	<u>Sub 12 - Old</u>	<u>Sub 12 - New</u>	<u>Z</u>
Flexion > 40°	.9250	.4730	8.867*	.2754	.3734	1.91
Flexion < 40°	.10625 n = 160	.5269 n = 167	8.867*	.7245 n = 164	.6265 n = 163	1.91
	<u>Sub 3 - Old</u>	<u>Sub 3 - New</u>	<u>Z</u>	<u>Sub 8 - Old</u>	<u>Sub 8 - New</u>	<u>Z</u>
Flexion > 40°	.2269	.0295	5.409*	.0503	.1962	3.94*
Flexion < 40°	.7730 n = 163	.9704 n = 169	5.409*	.9469 n = 159	.8037 n = 158	3.94*

Z Critical = 1.96

**Table 14** - Posture results for the shoulder show significant improvement for two of four subjects, and significant detriment for one of four subjects. The changes were not significant for one of four subjects.

	<u>Sub 2 - Old</u>	<u>Sub 2 - New</u>	<u>Z</u>	<u>Sub 12 - Old</u>	<u>Sub 12 - New</u>	<u>Z</u>
Flexion 6° - 30°	.21	.07	3.634*	.03	.03	0
Flexion > 30°	.79 n = 158	.93 n = 164	3.634*	.96 n = 164	.97 n = 163	.00
	<u>Sub 3 - Old</u>	<u>Sub 3 - New</u>	<u>Z</u>	<u>Sub 8 - Old</u>	<u>Sub 8 - New</u>	<u>Z</u>
Flexion 6° - 30°	.71	.60	2.805*	.16	.23	1.549
Flexion > 30°	.28 n = 161	.17 n = 164	2.376*	.84 n = 155	.76 n = 152	1.753

Z Critical = 1.96

**Table 15** - Posture results for head/neck flexion. One of four subjects experienced significantly increased head/neck flexion, while one showed significant decreases in head/neck flexion. Two of four showed no significant difference.



## REFERENCES

*American National Standard for Human Factors Engineering of Visual Display Terminal Workstations*, ANSI/HFS, Human Factors Society, Santa Monica, CA, 1988.

Aaras, A., R. Westgaard, E. Strandén, and S. Larsen, "Postural Load and the Incidence of Musculoskeletal Illness", Chapter 5 in *Promoting Health and Productivity in the Computerized Office*, Sauter, S., M. Dainoff, and M. Smith, editors, Taylor & Francis, Philadelphia, 1990.

Armstrong, T., and D. Chaffin, "Carpal tunnel syndrome and selected personal attributes", *Journal of Occupational Medicine*, 21, 481-486, 1979.

Armstrong, T., J. Foulke, B. Joseph, and S. Goldstein, "Investigation of cumulative trauma disorders in a poultry processing plant", *American Industrial Hygiene Association Journal*, 43, 2, 1982.

Armstrong, T., L. Fine, S. Goldstein, Y. Lifshitz, and B. Silverstein, "Ergonomics considerations in hand and wrist tendonitis", *Journal of Hand Surgery* 12A(5) part 2, 830-837, Sept., 1987a.

Armstrong, T., and B. Silverstein, "Upper-extremity pain in the workplace - role of usage in causality", in Hadler, N., *Clinical Concept in Regional Musculoskeletal Illness*, Grune & Stratton, Orlando, 1987b.

Armstrong, T., University of Michigan Engineering Short Courses, *Training Manual for Occupational Ergonomics I*, June 18-22, Ann Arbor, MI, 1990.

Basmajian, J., and C. De Luca, *Muscles Alive, Their Functions Revealed by Electromyography*, 5th Ed., Williams & Wilkins, Baltimore, MD, 1985.

Bleeker, M., "Medical Surveillance for carpal tunnel syndrome in workers", *The Journal of Hand Surgery*, 12A, pp. 845-848, 1987.

Brogmus, G., and R. Marko, "Cumulative Trauma Disorders of the upper extremities: the magnitude of the problem in U. S. industry", in *Proceedings of the International Ergonomics Association - Human Factors in Design for Manufacturability and Process Planning*, Honolulu, HA, August, 1990.

Brogmus, G., and R. Marko, "The proportion of cumulative trauma disorders of the upper extremities in U. S. industry", in *Proceedings of the Human Factors Society 36th Annual Meeting*, Human Factors Society, Santa Monica, CA, 1992.

Cannon, L., E. Bernacki, and S. Walter, "Personal and occupational factors associated with carpal tunnel syndrome", *Journal of Occupational Medicine*, vol. 23, no. 4, 255-258, April, 1981.

Chapanis, A., "The search for relevance in applied research", in *Measurement of Man at Work, An Appraisal of Physiological and Psychological Criteria in Man-Machine Systems*, Singleton, W., Fox, J. and Whitfield, D., editors, Taylor & Francis, London, 1971.

Feranadez, J., D. Malzahn, R. Marley, and A. Bonebrake, "A study of several performance measures of workers with carpal tunnel syndrome", in *Proceedings of the Human Factors Society 33rd Annual Meeting*, Human Factors Society, Santa Monica, CA, 1989.

Georgitis, J., "Extensor tenosynovitis of the hand from cold exposure", *Journal of Maine Medical Association*, 69, 129-131, April 1978.

Grandjean, E., *Fitting the Task to the Man, 4th Ed.*, Taylor & Francis, Philadelphia, 1988.

Gordon, C., E. Johnson, P. Gatens, and J. Ashton, "Wrist ratio correlation with carpal tunnel syndrome in industry", *American Journal of Physical Medicine & Rehabilitation*, pp. 270-272, 1988.

Gallimore, J., and M. Brown, "Effectiveness of the C-Sharp: reducing ergonomics problems at VDTs", *Applied Ergonomics*, Vol 24, no. 5, 1993.

Green, R., and C. Briggs, "Anthropometric dimensions and overuse injury among Australian keyboard operators", *Journal of Occupational Medicine*, vol. 31, no. 9, 1989.

Hadler, N., "Commentary: Cumulative Trauma Disorders, An iatrogenic concept", *Journal of Occupational Medicine*, 32, January, 1990.

Hadler, N., "Arm pain in the workplace - a small area analysis", *Journal of Occupational Medicine*, 34, no. 2, 113-119, February, 1992.

Hales, Thomas, National Institute of Occupational Safety and Health, Presentation to the National Safety Council Congress & Exhibition, Chicago, IL, October, 1993.

Harber, P., D. Bloswick, J. Beck, L. Pena, D. Baker, J. Lee, "Supermarket checker motions and cumulative trauma risk", *Journal of Occupational Medicine*, 35, no. 8, 805-811, August, 1993.

Hebert, L., "Body at work, *Occupational Health and Safety*, October, 1992.

Keyserling, M., L. Punnett, and L. Fine, "Postural stress of the trunk and shoulders: identification and control of occupational risk factors", in *Ergonomic Interventions to Prevent Musculoskeletal Injuries in Industry*. Lewis Publishers, Chelsea, MI, 1989.

Kiesler, S., and T. Finholt, "The mystery of RSI", *American Psychologist*, 43, pp. 1004-1015, 1988.

Konz, S., *Work Design: Industrial Ergonomics, 3rd Ed.*, Publishing Horizons, Worthington, OH, 1990.

Krammer, F., "Comparative risk of repetitive strain injuries by sex and occupation", in *Advances in Industrial Ergonomics and Safety IV, Proceedings of the Annual International Industrial Ergonomics and Safety Conference*, Taylor & Francis, Philadelphia, 1992.

Kroemer, K., "Avoiding cumulative trauma in shops and offices", *American Industrial Hygiene Association Journal*, 53, September 1992, pp. 596-604.

Kroemer, K. and S. Hill, "Preferred line of sight angle", *Ergonomics*, vol. 29, no. 9, pp. 1129-1134, 1986.

Lutz, G., and T. Hansford, "Cumulative trauma disorder controls: the ergonomics program at Ethicon, Inc.", *Journal of Hand Surgery*, 12A, [2 Pt 2], pp. 863-6, 1987.

Margolis, W., and J. Kraus, "The prevalence of carpal tunnel syndrome symptoms in female supermarket checkers", *Journal of Occupational Medicine*, 12, 953-956, 1987.

Nathan, P., K. Meadows, and L. Doyle, "Occupation as a risk factor for impaired sensory conduction of the median nerve at the carpal tunnel", *Journal of Hand Surgery*, vol. 13, no. 2, May, 1988.

Nathan, P., R. Keniston, L. Myers, and K. Meadows, "Obesity as a risk factor for slowing of sensory conduction of the median nerve in industry", *Journal of Occupational Medicine*, 34, no. 4, 379-383, April 1992.

Nathan, P., Portland Hand Surgery and Rehabilitation Center, Presentation to the National Safety Council Congress & Exhibition, Chicago, IL, 1993.

Press, W., S. Teukolsky, W. Vetterling, B. Flannery, *Numerical Recipes in C, The Art of Scientific Computing*, Cambridge University Press, New York, NY, 1992.

Putz-Anderson, V., Editor, *Cumulative Trauma Disorders - A Manual for Musculoskeletal Diseases of the Upper Limbs*, Taylor & Francis, Philadelphia, 1988.

Radwin, R., T. Armstrong, and D. Chaffin, "Power hand tool vibration effects on grip exertions", *Ergonomics*, 30, pp. 833-855, 1987.

Sauter, S., M. Dainoff, and M. Smith, editors., *Promoting Health and Productivity in the Computerized Office*, Taylor & Francis, Philadelphia, 1990.

Schotland, J., G. Kirschberg, R. Fillingim, V. Davis, and F. Hogg, "Median nerve latencies in poultry processing workers: an approach to resolving the role of industrial "cumulative trauma" in the development of carpal tunnel syndrome", *Journal of Occupational Medicine*, vol. 33, no. 5, 627-631, May, 1991.

Silverstein, B., L. Fine, and T. Armstrong, "Hand-wrist cumulative trauma disorders in industry", *British Journal of Industrial Medicine*, 43, 779-784.

Silverstein, B., L. Fine, and T. Armstrong, "Occupational factors and carpal tunnel syndrome", *American Journal of Industrial Medicine*, 11, 343-358, 1987.

Silverstein, B., T. Armstrong, A. Longmate, and D. Woody, "Can in-plant exercise control musculoskeletal symptoms?" *Journal of Occupational Medicine*, vol. 30, no. 12, 1988.

Silverstein, B., and L. Fine, "Commentary: Cumulative Trauma Disorders of the upper extremity, a preventive strategy is needed", *Journal of Occupational Medicine*, 33, no. 5, May 1991.

Smutz, W., Bloswick, D., and France, E., "An investigation into the effect of lowforce high frequency manual activities on the development of carpal tunnel syndrome", *Advances in Industrial Ergonomics and Safety IV*, Taylor & Francis, Philadelphia, 1992.

Stock, S., "Workplace ergonomic factors and the development of musculoskeletal disorders of the neck and upper limbs: a meta-analysis", *American Journal of Industrial Medicine*, 19:87-107, 1991.

Szabo, R., and R. Gelberman, "The pathophysiology of nerve entrapment syndromes", *Journal of Hand Surgery*, vol. 12A, no. 5, part 2, 1987.

Tanaka, S., P. Seligman, W. Halperin, M. Thun, C. Timbrook, and J. Wasil, "Use of worker's compensation claims data for surveillance of cumulative trauma disorders", *Journal of Occupational Medicine*, vol. 30, no. 6, 488-492, June, 1988.

Thomas, R., R. Butterfield, J. Hool, and R. Herrick, "Effects of exercise on carpal tunnel syndrome symptoms", *Applied Ergonomics*, vol. 24, no. 2, 1993.

Thompson, D., "Effect of exercise breaks on musculoskeletal strain among data entry operators: a case study", in *Promoting Health and Productivity in the Computerized Office*, Sauter, S., M. Dainoff, and M. Smith, editors, Taylor & Francis, Philadelphia, 1990.

Tichauer, E., "Some aspects of stress on forearm and hand in industry", *Journal of Occupational Medicine*, 8, 63-71, 1966.

Tichauer, E., and H. Gage, "Ergonomic principles basic to hand tool design", *American Industrial Hygiene Association Journal*, 38, 11, 1977.

Tsai, S., E. Gilstrap, S. Cowles, L. Waddell, and C. Ross, "Personal and job characteristics of musculoskeletal injuries in an industrial population", *Journal of Occupational Medicine*, 34, no. 6, 606-612, June 1992.

Westgaard, R., and A. Aaras, "Postural muscle strain as a causal factor in the development of musculo-skeletal illnesses", *Applied Ergonomics*, 15.3, 162-174, 1984.

Westgaard, R., M. Waersted, T. Jansen, and A. Aaras, "Muscle load and illness associated with constrained body postures", in *The Ergonomics of Working Postures*, Corlett, N., J. Wilson, and I. Manenica, editors, Taylor & Francis, Philadelphia, 1986.

Williams, T., L. Smith, and R. Herrick, "Exercise as a prophylactic device against carpal tunnel syndrome", in *Proceedings of the Human Factors Society 33rd Annual Meeting*, Santa Monica, CA, 1989.