

Copyright Warning & Restrictions

The copyright law of the United States (Title 17, United States Code) governs the making of photocopies or other reproductions of copyrighted material.

Under certain conditions specified in the law, libraries and archives are authorized to furnish a photocopy or other reproduction. One of these specified conditions is that the photocopy or reproduction is not to be “used for any purpose other than private study, scholarship, or research.” If a user makes a request for, or later uses, a photocopy or reproduction for purposes in excess of “fair use” that user may be liable for copyright infringement,

This institution reserves the right to refuse to accept a copying order if, in its judgment, fulfillment of the order would involve violation of copyright law.

Please Note: The author retains the copyright while the New Jersey Institute of Technology reserves the right to distribute this thesis or dissertation

Printing note: If you do not wish to print this page, then select “Pages from: first page # to: last page #” on the print dialog screen

The Van Houten library has removed some of the personal information and all signatures from the approval page and biographical sketches of theses and dissertations in order to protect the identity of NJIT graduates and faculty.

ABSTRACT

ANALYSIS OF A DESIGN FOR ITS QUALITY MANUFACTURABILITY IN TERMS OF MISALIGNMENTS AND FASTENER RELATED PROBLEMS.

**by
Abhinav Dhar**

This study analyzes the relationship between design parameters established at the initial stage of the design process and the manufacturing quality problems that manifest themselves during production. Specifically, we study the relationship between design features and the occurrence of misalignment defects and fastener related problems.

This outcome of this work is a methodology, Design for Quality Manufacturability (DFQM). DFQM addresses the likelihood that defects will occur during the manufacture of a product in a standard plant. This is based on the premise that defects in assembled products are often influenced by some features of the design and/or assembly process. These are referred to as 'Factor Variables' and they catalyze defects in certain combinations by promoting error catalysts.

The error catalysts that could cause misalignments or fastener related problems are identified and documented. Also, in order that the analysis of functional & positional relationships between various parts and fastener parameters can be effectively utilized in the methodology, matrices are created to represent these relationships and parameters. The error catalysis graphs provide us with numbers representing likelihood of the occurrence of misalignments/fastener related problems which are then analyzed to obtain the QM score for the design.

**ANALYSIS OF A DESIGN FOR ITS
QUALITY MANUFACTURABILITY IN TERMS OF
MISALIGNMENTS AND FASTENER RELATED PROBLEMS.**

**by
Abhinav Dhar**

**A Thesis
Submitted to the Faculty of
New Jersey Institute of Technology
in Partial Fulfillment of the requirements for the Degree of
Master of Science in Industrial Engineering**

Department of Industrial and Manufacturing Engineering

May 1995

Blank Page

APPROVAL PAGE

ANALYSIS OF A DESIGN FOR ITS
QUALITY MANUFACTURABILITY IN TERMS OF
MISALIGNMENTS AND FASTENER RELATED PROBLEMS.

Abhinav Dhar

Dr. Sanchoy K. Das, Thesis Advisor
Associate Professor of Industrial Engineering, NJIT

Date

Dr. Layek Abdel-Malek, Committee Member
Professor of Industrial Engineering, NJIT

Date

Dr. Rajpal S. Sodhi, Committee Member
Professor of Mechanical Engineering, NJIT

Date

BIOGRAPHICAL SKETCH

Author: Abhinav Dhar

Degree: Master of Science in Industrial Engineering

Date: May 1995

Undergraduate and Graduate Education:

- Master of Science in Industrial Engineering,
New Jersey Institute of Technology, Newark, New Jersey, 1995
- Bachelor of Engineering in Mechanical Engineering,
University of Mysore, Mysore, India, 1993

Major: Industrial Engineering

Presentations and Publications:

Golgen Bengu, Biren Prasad, Abhinav Dhar

“A multi-agent based cooperative framework to support concurrent engineering.”

First International Conference on Concurrent Engineering.

Pittsburgh PA. August 1994.

This Thesis is dedicated to
my parents, sisters and friends.

ACKNOWLEDGMENT

The author wishes to express his profound gratitude to his advisor, Dr. Sanchoy K. Das, for his supportive demeanor, brilliant guidance and encouragement throughout this research.

Heartfelt gratitude to Dr. Layek Abdel-Malek and Dr. Rajpal S. Sodhi for serving as members of the committee.

The author acknowledges the National Science Foundation for partial funding of the research.

The author is grateful for the constructive criticisms and help from Mr. Cyrus Chu of General Motors, Linden, New Jersey; Dr. Prashanth Nagendra, and colleagues Mr. Suriyanarayanan Ramachandra and Mr. Altaf Tamboo. The author also wishes to acknowledge Ms. Alicia Suh for her assistance in documenting the research work and assisting in the lab.

Dr. Herman A. Estrin provided expert assistance on thesis format in his book on theses writing and the workshop.

Last but not least, the author would like to thank Dr. Ronald Kane and Ms. Annette Damiano for their time and the help they rendered in the documentation of this thesis.

TABLE OF CONTENTS

Chapter	Page
1 INTRODUCTION.....	1
1.1 The Quality Syndrome.....	2
1.2 Design for Quality Manufacturability (DFQM).....	3
1.3 Research Objective.....	4
1.4 Organization of the Thesis.....	5
2 LITERATURE SURVEY.....	6
2.1 Concurrent Engineering.....	6
2.2 Design for Manufacturability and Assembly (DFMA).....	8
2.3 DFX.....	10
2.4 The Concepts of Quality.....	11
2.5 Summary.....	13
3 MATRICES BASED ANALYSIS OF FASTENERS AND RELATIONSHIPS....	14
3.1 Fasteners.....	14
3.2 Positional Relationships.....	15
3.3 Functional Relationships.....	16
3.4 Classification of Fasteners from the DFQM Perspective.....	16
3.5 Fastener Classification Chart.....	18
3.6 Classification of Positional Relationships from the DFQM Perspective.....	20
3.7 The Positional Relationship Chart.....	21

TABLE OF CONTENTS
(Continued)

Chapter	Page
3.8 Classification of Functional Relationships from the DFQM Perspective.....	23
3.9 The Functional Relationship Chart.....	26
4 DFQM ANALYSIS OF FASTENER RELATED PROBLEMS.....	28
4.1 The Role of Fasteners in Quality Manufacturability.....	28
4.2 The DFQM Scheme and Mechanism.....	29
4.3 The Composition of Error Catalysts.....	30
4.4 The Quality Manufacturability (QM) Analysis.....	31
4.5 Analysis of Fastener Related Problems.....	33
4.5.1 Loose or Ill Fitting Fasteners.....	33
4.5.2 Overtightening.....	38
4.5.3 Fracture or Failure.....	42
4.6 The Results Based on the Analysis.....	46
5 DFQM ANALYSIS OF MISALIGNMENTS.....	48
5.1 Misalignments as a Manifestation of QM.....	48
5.2 Analysis of Misalignments.....	50
5.2.1 Axial Misalignment.....	50
5.2.2 Radial Misalignment.....	54
5.2.3 Angular Misalignment.....	59
5.2.4 Linear Misalignment.....	63

TABLE OF CONTENTS
(Continued)

Chapter	Page
5.2 QM Results Based on the Analysis.....	67
6 CONCLUSIONS AND FUTURE WORK.....	69
6.1 Conclusions.....	69
6.2 The Computer (P.C.) Based Front End.....	70
6.3 Future Work.....	72

TABLE OF CONTENTS
(Continued)

Chapter	Page
APPENDIX A : DFQM CLASSIFICATION OF PARTS BY SYMMETRY AND GEOMETRY.....	73
APPENDIX B : DFQM SCHEMATIC.....	74
APPENDIX C : FIRST SCREEN OF THE DFQM APPLICATION.....	75
APPENDIX D : A SCREEN OF THE DFQM APPLICATION.....	76
REFERENCES.....	77

LIST OF TABLES

Table	Page
4.1 Metrics Involved in Quantification of Factor Variables.....	31

LIST OF FIGURES

Figure	Page
1.1 Diagram showing the stages worked on and areas that need work.....	5
3.1 Fastener classification and identification chart.....	19
3.2 Positional relationship classification and identification chart.....	22
3.2.1 Installation of cover on a box as an illustration of positional relationships....	23
3.3 Functional relationship charts.....	25
4.1 Format for the quality manufacturability matrix (QMM).....	32
4.3 Catalysis Graph for thermal expansion and contraction.....	35
4.4 Catalysis Graph based on reduced area.....	36
4.5 Catalysis Graph for too many standard sizes.....	37
4.6 Relative weightage of error catalysts for loose or ill-fitting fasteners.....	34
4.7 Relative weightage of error catalysts for overtightening.....	39
4.8 Catalysis Graph for fastener type and application.....	40
4.9 Catalysis Graph for stress variation.....	41
4.10 Catalysis Graph for power tools.....	44
4.11 Catalysis Graphs for dislocating stress.....	45
4.12 Relative weightage of error catalysts for fracture or failure.....	43
4.13 Relative weightage of specific defects in the defect class fastener related problems.....	46
5.1 Conceptual diagram to illustrate misalignments.....	49
5.2 Relative weightage of error catalysts for axial misalignment.....	50

LIST OF FIGURES
(Continued)

Figure	Page
5.3 Inability to simultaneously align all mating features.....	51
5.4 Effects of differential thermal expansion.....	52
5.5 Fastener effects.....	53
5.6 Symmetrical influences.....	55
5.7 Thermal effects.....	56
5.8 Fastener effects.....	57
5.9 Relative weightage of error catalysts for axial misalignment.....	58
5.10 Angular orientation and cantilever.....	60
5.11 Fasteners effects.....	61
5.12 Relative weightage of error catalysts for axial misalignments.....	62
5.13 Relative weightage of error catalysts for axial misalignment.....	63
5.14 Effects of mating complexity.....	64
5.15 Effects of differential thermal expansion.....	65
5.16 Effects of fastener selection.....	66
5.17 Relative weightage of specific defects in the defect class misalignments.....	68
6.1 Conceptual architecture of the DFQM database application.....	71

CHAPTER 1

INTRODUCTION

Production in modern terms is described by two major types of industries. *Manufacturing companies* which are typically identified with discrete-item production e.g. assembly of products and their components and the *process industries* which are represented by chemicals, plastics, petroleum etc. In the case of manufacturing companies, a product or a component has to be first conceived, then designed and finally manufactured. The time interval from the initial stage of conception to the final stage when the product can be marketed is known as the design life cycle time. This time has increasingly become a measure of competitiveness in modern manufacturing. It is also important to note that in addition to time, the total cost is also a concern during the design life cycle. This total cost can be considered as the sum of several sequential costs. Each of these costs are a function of decisions made in an earlier stage. Clearly then, to reduce costs we need to take a look ahead approach in the design process.

In order to continuously improve products and to introduce new products we need to drastically reduce the transition time and total cost from design to manufacturing. This can be done if at the design stage we can somehow identify the possible reasons why any design would run into manufacturability or quality problems later on and try to remove them.

In the majority of companies, design to manufacturing transition is a slow and painful process due to an iterative improvement process. Typically, the design is bounced

between the design and manufacturing departments, during which a series of iterative changes are made. If manufacturing and design personnel can concurrently review the design then most of the downstream problems can be corrected as soon as they are created at the design stage. To facilitate this process companies are adopting concurrent engineering and or Design for Manufacturability(DFM) techniques. These are basically techniques by which design teams can identify flaws in the designs from a manufacturing perspective and remove them right at the drawing board. This reduces lifecycle times and associated costs and also helps the designers to continuously improve their product for its manufacturability by using previous results as benchmarks.

1.1 The Quality Syndrome

In American manufacturing quality is no longer an auxiliary function to manufacturing, rather it is one of the primary performance goals. This has extended quality programs from (process) quality monitoring and control (embodied in the SPC/SQC approach) to include total quality management (TQM). This has made quality a part of all functions in the organization and it has also introduced the concept of quality being priority number one.

Traditionally the chronological sequence of events in the design cycle was: the design was approved, manufactured and (iteratively) all the manufacturing problems were removed. After this sequence, the products were manufactured with good quality. However, if the product quality is flawed or the design of the product hinders the production of a quality product then any organization becomes incapable of manufacturing a quality product in the anticipated time period. In order to remove this

manufacturability of a product but also the quality manufacturability of the product. This makes sure that unanticipated problems at the design stage do not affect the manufactured quality of the product. This concept is presented as Design for Quality Manufacturability (DFQM).

In order that the concept can be translated into reality, a methodology has to be established such that a consistent result or indicator of the Quality manufacturability (QM) can be obtained and the designs be evaluated. If the methodology can be presented in the form of a simple and easy to use computer application then designers can effectively control the QM characteristics of any product.

The QM index could be very helpful in life cycle engineering and strategic planning for manufacturing organizations. This is because of two reasons, firstly it concentrates on downstream issues at a very early stage and thus is able to provide valuable information to designers which otherwise would be available to them much later. Secondly, it focuses the attention of the organization on product quality at the stage where most decisions are made about the product and most of the expenditure is committed. In competitive environments where product life cycles are shortening and turnaround times are small, this methodology could ultimately prove to be a valuable tool for the modern manufacturing organization to not only stay alive but also be competitive.

1.2 Design for Quality manufacturability (DFQM)

Using the concepts stated earlier and realizing the benefits associated with the development and subsequent use of such a methodology the author in this thesis attempts to present part of such a methodology.

The basic objective of DFQM is to enable the user to improve the design so as to reduce the likelihood of a defective product being manufactured. It is an approach which would analyze a design for the likelihood of quality problems that might arise during its manufacture. For example, excessive number of mating surfaces are likely to influence misalignment between two parts in an assembly.

DFQM intends to analyze the implications of the design on manufacturing. Hence it does not evaluate the design for its quality in isolation but instead presents an index which provides us with a number representing the quality of the design from the perspective of manufacturing.

1.3 Research Objective

This thesis forms part of a three year research project on DFQM which is currently underway. The research is partially funded by a grant from the national science foundation(NSF). The stages already worked on are shown in figure 1.1. The objectives of the work can be summarized as:

- To provide a detailed analysis of all the factor variables involved in the catalysis of various specific defects. Specifically, to provide a reference for classifying and identifying the various fastener related parameters and various functional & positional relationships.
- To analyze and document in detail, the error catalysts and corresponding catalysis graphs for the defect classes misalignments and fastener related problems.
- This thesis also intends to introduce the conceptual architecture involved in creating a computer application for this thesis.

1.4 Organization of the Thesis

This thesis consists of six chapters. The first chapter introduces the concepts leading up to and the actual content of DFQM and their importance in modern manufacturing. Chapter two gives a review of the literature pertaining to DFA/DFM and current research in the area of concurrent engineering. Chapter three presents the classification of positional and functional relationships between parts in an assembly so that they can be utilized in the methodology. It also presents the classification and identification of fasteners from the perspective of DFQM. QM analysis of misalignments and fastener related problems is presented in chapter four and five. Finally, chapter six contains conclusions and scope for further research in the area of DFQM.

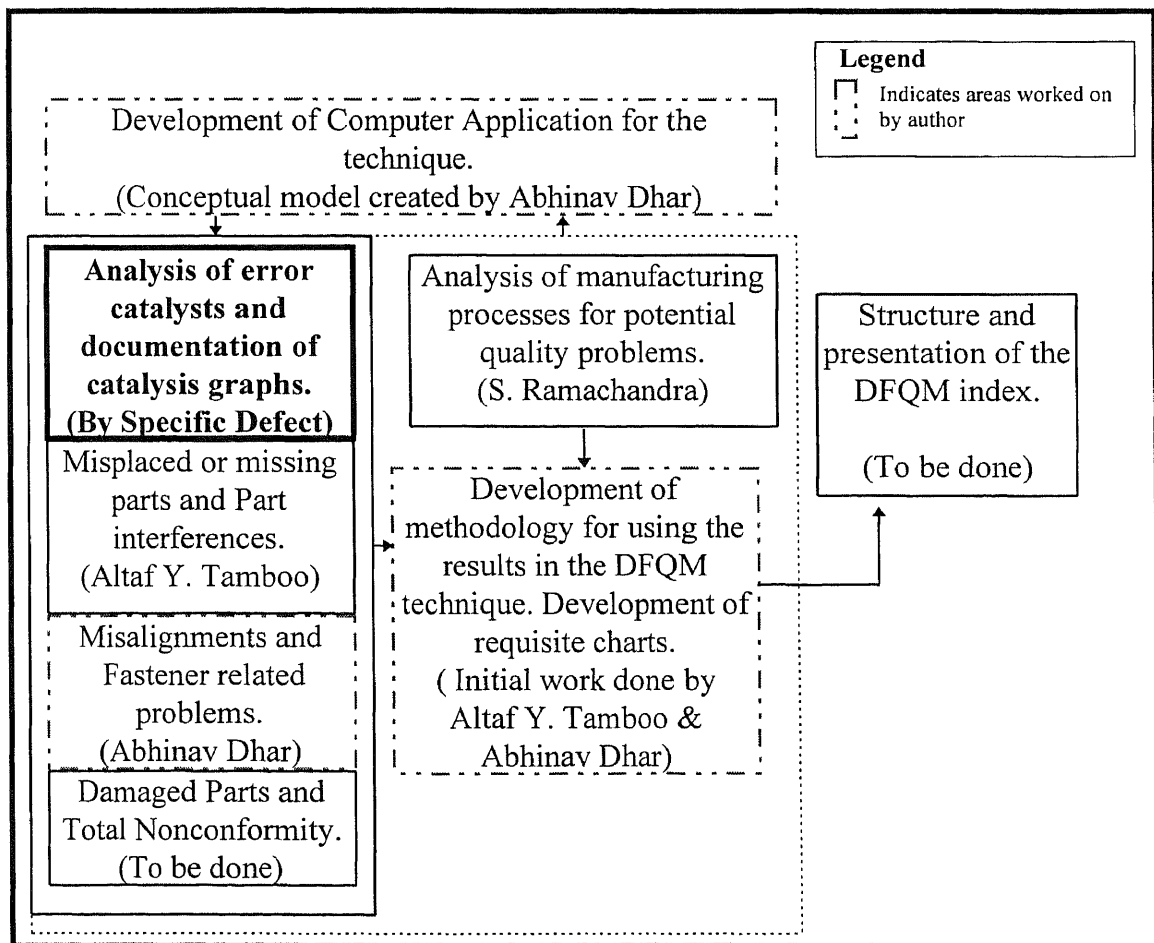

Figure 1.1 Diagram showing the stages worked on and areas that need work.

CHAPTER 2

LITERATURE SURVEY

Companies relying on traditional ways of designing new products and bringing them to market are facing stiff competition from world class companies. Several books, articles, and academic research have recently focused on the disparity that exists between companies in terms of product development costs and cycle times. This global competition and high performance behavior has thrown up a panoply of techniques for developing and manufacturing high quality products. These techniques come under the heading, concurrent engineering (CE). This concept is being used by many companies with the aid of multifunctional teams and associated tools. These tools include techniques like Design for Manufacturability (DFM), Design for Xs (DFX), Quality Function Deployment (QFD) and Total Quality Management (TQM). These topics have been discussed in this chapter with reference to the literature available on them and their relevance to DFQM.

2.1 Concurrent Engineering

In CE, the key ingredient is teamwork. People from many departments collaborate over the life of a product - from idea to obsolescence - to ensure that it reflects the customers needs and desires. With CE, no longer does marketing give product specifications as a *fait accompli* to engineering. This changes the concept of *tossing the design over the wall* to *tossing the engineer over the wall*.

The concept of concurrent engineering is currently being explored in different ways. There is extensive research going on to explore ways and means to translate this concept into a quantifiable and measurable technique. DFM is one such approach. In the literature, one finds several case studies describing companies that have successfully utilized these concepts to enhance their competitiveness in the market. These companies are as diverse in their products as they are in their sizes. These companies range from electronic manufacturing giant Hewlett Packard and auto giant General Motors to small companies like Coors Ceramics and Mercury Computers and have catalogued their experiences with concurrent engineering. The references to these well publicized instances can be found frequently. Shina, Sammy D. has extensively written on the concepts, application and techniques in CE in a lot of articles, papers and one book.

The focus of most of these articles has however been on CE through teams. They have been called by various people differently but basically they are multifaceted business teams, inherently crossfunctional in nature. A detailed analysis of the composition and function of these teams is also available from the 'PAFs' of Sun Microsystems (Siegal B.) to the defense run 'Tiger Teams' of the DARPA/DICE initiative (Reddy R., Wood R. T., Cleetus J. K.).

The team based approach has also been taken forward to include the communication setup or software setup to support this CE without physical concurrence. This produces a kind of virtual concurrence by allowing physically remote members of teams to interact in the product development process and also include design tools like CAD and prototyping to see the result of conceptual design changes immediately. (Bengu, G., Prasad, B., Dhar, A.).

Most cases of use catalogued in literature are in electronic assembly however some non-electronic manufacturing companies like General Motors etc. have also used this methodology successfully. The research is concentrated upon the use of decision support environments for CE, integration of CAD and other special purpose tools and conflict resolution techniques. Information technology lends itself very well to the concept of CE so a lot of research is concentrated in that area.

2.2 Design for Manufacturability and Assembly (DFMA)

DFMA is both a philosophy of design and a software package that alerts design engineers to the manufacturing implications of their work. The concept of letting the manufacturers have a say in the design was practiced in several organizations of the world for a long time. However, it was recently, when Geoffrey Boothroyd, a manufacturing engineer got together with Peter Dewhurst, a software engineer to develop a set of application-specific computer programs (Boothroyd and Dewhurst) that designers could quickly and accurately estimate the effort involved in manufacturing. This gives them time to evaluate their work before it is too late to consider the alternatives. The field of Design for Manufacturability or DFM as it is known has grown to include other techniques and methodologies, generic as well as custom made, using which a certain farsightedness can be provided to the designer in terms of output from manufacturing. The single largest used and probably the only commercially available version of a generic DFM methodology is the one developed by Boothroyd and Dewhurst.

The literature is full of articles where organizations and designers have used DFM and DFMA to enhance product designs and thus fundamentally increasing their competitiveness and drastically reducing the overall product development effort. Organizations with documented use are Hewlett- Packard, IBM, GM, Sun Microsystems, Polaroid, Coors Ceramics, Masco Machine, Hendry Telephone, Middleby Cooking Systems Group etc. etc. the list is endless.

Research in this area includes use of neural networks and computer based modeling to aid DFM (Chu and Holm), simultaneous engineering management (Moskal, Brian), integration of tolerances and process capabilities with DFM at different points into the design and development process (Potechin, Jamey) and the implementation of DFM automatically with CAD data (Marsh, Michael).

A serendipitous discovery with the advent of DFM has been that the reduction of the number of parts in any product greatly enhances it's manufacturability and ease of assembly. This is a direct offshoot of the Boothroyd and Dewhurst approach. This concept however has led to creation of complicated shapes and the reduction in the number of total fasteners and excessive use on non traditional fasteners. A lot of material is available on the problems associated with, development and the possibilities of use of snap fitting fasteners (Bonenberger, Paul) and adhesives (Cocco et al) (Johnson) (Telo and Knight). It also becomes evident that these concepts of redesigning multi functional complex shapes and reduction of fasteners creates issues which could adversely affect the quality of the finished product.

The benefits associated with DFM are many. DFMA gives users a benchmark for product concept designs against a theoretical assembly index that is offered through the

DFMA techniques. When implemented to the fullest, DFMA offers other gains that can result in reduced inventories, paperwork, labor and warranty costs.

A conspicuous absence of published work on Design for Quality or Design for Quality Manufacturability is noticed. The perspective of designing the DFM structure such that concrete and real manufacturing time quality problems can be addressed and quantified has not been explored. Most of the articles assume that since the manufacturability of the product improves the quality of the product also improves.

2.3 DFX

Taking the concept of DFM further and realizing the tremendous amount of control that the design stage can impose upon the downstream functions and problems associated with the product; various methodologies to analyze for 'Xs' have been proposed. The 'Xs' in this case could be many. They range from subjects like serviceability and maintainability to Schedulability. Some of these have been presented in literature and are briefly discussed here.

Design for schedulability (Kusiak, Andrew and He, Weihua) takes into consideration the operations aspect of the manufacture of products and parts. In this methodology Kusiak and He present five design rules which are measured for impact on quality of the schedule with the makespan and average machine utilization. These design rules are also substantiated with numerical results.

Quite often in design of products, especially PCBs the testing of products is ignored. Since the design of PCBs includes distinct and varied design of ICs, ASICs, FPGAs, PLDs and boards they must be testable at manufacturing. Thus the designers has

to take into consideration the testability of the PCB (Grzesik, Tony). This may involve not only setting up a test strategy for each board at the design stage itself but also providing test access to each of the nodes that will be tested. This concept is taken at a generic level to any product design since testing is very important for the measurement and control of quality.

A direct relation between the design of the product and the manufactured quality is proposed by Das and Prasad. This can help the designer in not only optimizing the manufacturability of the product but also allows him to address multiple quality issues that could affect the product at a downstream stage. These works form the basis for the present work.

The other analogous methodologies that have been developed are, design for maintainability, design for repeatability etc. etc. All these are basically analogues of the DFM applications where the criticality of a certain downstream issue is addressed at the design stage thus indirectly affecting the performance quality of the product. This gives the organization power to predict and plan for a lot of possibilities which were previously considered unforeseeable.

2.4 The Concepts of Quality

Traditionally quality has been viewed from the perspective of statistical methods initially developed by Shewhart, W. A. This has made quality synonymous with SPC/SQC. This perspective can be described as, *“Measured quality of a manufactured product is always subject to a certain amount of variation as a result of chance. Some stable ‘system of causes’ is inherent in any particular scheme of production and inspection. Variation*

within the stable pattern is inevitable. The reasons for variation outside this stable pattern may be discovered and corrected." (Grant & Leavenworth). This methodology is process intensive in the sense that when the product has been designed and approved and is being manufactured we tend to control the quality of the manufactured product. In assured markets and longevity of product life cycles we can safely depend on such a methodology as the only approach to quality. However if the time taken to design the product and get all the manufacturing bugs out is long drawn then the capability to control the quality of product manufacture may be inconsequential. We need to make quality all pervading so that not just manufacturing is quality controlled but also is design or marketing etc.

This recently discovered need has spawned techniques like TQM and ISO 9000. Also the criticality of quality and turnaround time with respect to market dominance has led to an increased emphasis on it. This is mirrored in the growth of ISO9000 registrations over the past several years. ISO registration has become the accepted standard for measuring an organization's quality management program. American manufacturers are improving their production processes and protecting or expanding export markets by developing quality-management systems which embrace the all pervadingness and totality of quality. In essence, they are building quality into the product. This phenomenon of organizational involvement in quality is known as Total Quality Management or 'TQM'.

These methodologies of TQM and ISO9000 registration have a lot of primary and secondary benefits. Among the measurable benefits are lower scrap costs, fewer rejects and better ontime delivery. Other advantages include better communication between

departments, empowerment of employees and not being shut out of markets which need a demonstration of the adherence to these principles in the form of tangible proof like the registration.

The shortcoming of these methodologies is that they tend to be management philosophies and production and performance intensive methods. The concept of concurrence and design time decision support may not get directly addressed.

2.5 Summary

CE has opened a whole new approach to product design. The importance of design time decisions and their far reaching implications has created a lot of methodologies and softwares which can be utilized to enhance the predictive capability of the designer in terms of testability, schedulability, manufacturability etc. Utilizing these established methodologies designers can reduce the number of iterations traditionally involved in the design thus greatly reducing the development time. This power to effectively predict and control downstream issues has been developed into application softwares which helps designers to objectively analyze their designs and address areas which need addressing.

The quality of the product has by and large been reduced to a post design function. Present thought assumes that the quality of the product is independent from the design in the sense that improved manufacturability guarantees improved quality so there is little emphasis on the design for manufacturability perspective. This area is recognized for its importance and is addressed in this thesis.

CHAPTER 3

MATRICES BASED ANALYSIS OF FASTENERS AND RELATIONSHIPS

The analysis of assemblies is complicated by the fact that there are several interacting parts and fasteners. The QM analysis of the assembly cannot focus on each component in isolation, but rather must focus on the relationships between various components. This creates a need to identify and classify relationships and fasteners in a way which captures these interrelationships. Matrix based data analysis provides an effective way for capturing interrelationship data. The matrices permit easy cross reference and also aid in the group analysis methodology that the representative figures in our charts follow. In this chapter these methods of classification are presented.

3.1 Fasteners

In the manufacture of any product the quality of assembly depends on the quality of its fasteners. Fasteners also are quite often the most numerous component of an assembly. Since fasteners constitute a large portion of assembly time and operation, they are potential sites of defects. Using Boothroyd and Dewhurst's Design for Manufacturing and Assembly methodology we tend to reduce the numbers of fasteners, this affects the whole macro variable (Fastener number) and thus controls the quality problems with fasteners.

However, if we can identify what parameter of the fastening system causes the quality problem, we can substitute one type of fastener for another or make appropriate design changes thus avoiding the redesign of the whole component or the assembly. This

reduces design time because it saves the organization significant amount of design time and effort. Also, it is important to note that the installation cost in fasteners may be five times the cost of the fasteners themselves. Hence, if we reduce the number of fasteners without significantly affecting the installation costs then it might be a better idea to analyze the fastener installation rather than the fastener number.

Fasteners are traditionally classified as either removable like screws, or semi-permanent like rivets, or permanent like welds. Other classification schemes are also used but none is appropriate from the perspective of our methodology. Analysis of fasteners is also complicated by the fact that in addition to providing structural support they are used for a variety of other purposes including nonmagnetic properties, for corrosive or other environmental exposure conditions, or even decorative appearance.

Installation of fasteners is a critical issue in QM analysis. If fasteners are not tight enough, stress fluctuations in the joint will lead to fatigue failure. Conversely, overtightening can result in fracture or plastic elongation of the fastener. Loss of clamp force, in turn, will give rise to the same dynamics which cause fatigue failure.

3.2 Positional Relationships

Any product assembly is a system. Since the various components of an assembly need to work together towards a common goal there is interaction between the various components of the assembly. We need to analyze these relationships in order to understand their dynamics and thus make a prognosis on the potential defects at the relationship level. Position of components with respect to each other can seriously affect the alignment of components or it may also cause them to be misplaced or mispositioned.

Since position determines structural as well as functional capabilities of the assembly, the relationships commonly encountered in terms of position are analyzed from the quality manufacturability perspective in this chapter. This involves the type of relationship, the ratios of contact etc. Since locators play a prominent part in determining the position of various components, we also incorporate them into the analysis.

3.3 Functional Relationships

Each and every component in an assembly has a function. This function could be intrinsic to the assembly or it may be an assembly function which the component provides in sync with the functions of the other various components. This leads us to believe that there is transfer of functionality from component to component. Possibly, this transfer also includes transfer of error or defects. Since defects can be transferred through function improperly executed, we need to analyze the functional relationships between the various components of the assembly.

Functional relationships are basically of two kinds, those involving motion and those involving no motion. Motion could be continuous or otherwise. Functions could be structural or cosmetic etc. These various relationships are comprehensively catalogued and analyzed in this chapter.

3.4 Classification of Fasteners from the DFQM Perspective

The matrix used here is more an identification chart than a classification chart. We need to identify the requisite parameters in any fastening system for our methodology to analyze the quality index of the system. The various parameters have been identified as:

Direction of separation force, Force mapping ratio, Fastening accessibility, Application of fasteners, Inter fastener distance and Constituent components. Each of these are explained below.

1. *Direction of separation force*: Since the fasteners tend to fail in the direction of the separating force we need to analyze the fasteners for the direction of the separating force. This separating force could be in the direction of most resistance in the assembly thus reducing the possibility of failure greatly. However, in situations where the fasteners are acted upon by a force acting away from the assembly or in a direction of reduced resistance then the possibility of failure is increased a lot. The various possibilities are analyzed in relation to the fastening axis, they could be parallel, perpendicular, or at an angle to it. They could also be eccentric or an impact from any direction.
2. *Force mapping ratio*: The stress distribution over the contact area determines the strength of the joint to a large extent. This distribution is enveloped by the area mapped by the fasteners between themselves. Hence the force mapping ratio is in effect the area mapped by the fasteners divided by the total surface area of the joint. The various possibilities are 25%, 50%, 75% or a 100%.
3. *Fastening accessibility*: This is a major factor in the ease of installation of the fastener. In top down assemblies it is not much of a problem except in some special cases. However, since it is not possible to create all assemblies as top down we need to catalogue the various possible accessibility conditions. These are visualized in terms of accessible directions and they range from 1 to 5 directions of accessibility.

4. *Application of fastener*: The methodology followed in installing the fastener are critical for the designer to apply the DFQM concepts because the requirements for manual, semi-automatic and fully automatic installation are totally different. The manual assembly though flexible is not effective in volume manufacturing because of its inconsistent nature. Automatic without preload correction e.g. in power tools is consistent but accuracy may not be very good. Automatic with preload correction is the most accurate and consistent. Since preload is the prime determining factor in fastener failure, this analysis is very important.
5. *Inter fastener distance*: These determine the difficulty of an installation operation. To understand the error probability in fastener installation it is important to correlate it with the installation difficulty. Difficulty could be due to the fact that the fasteners are at different distances in the pattern making automation difficult. Also, if the planes of fastener installation are different the problems are compounded.
6. *Constituent components*: The number of constituents in a fastening system directly affects missing components, mispositioning etc. The number of components in a fastening is pretty quantitative. It could be one like a screw or weld, two like nut and bolt or three like a nut, bolt and washer.

3.5 Fastener Classification Chart

The Fastener Classification and Identification chart is shown in figure 3.1. The columns include representative figures in each category of analysis. These categories have been explained above and the columns are represented by alphabets A through F. Each category has different possibilities which have been illustrated.

FASTENER CLASSIFICATION AND IDENTIFICATION CHART

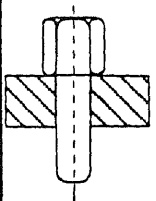
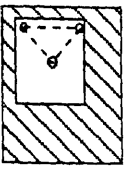
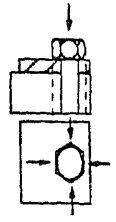
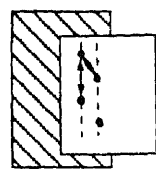
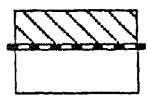
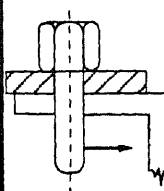
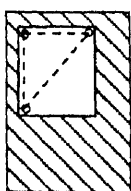
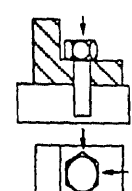
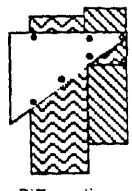
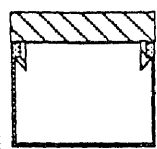
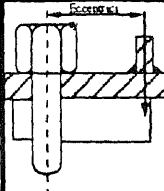
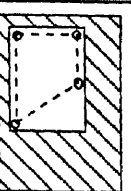
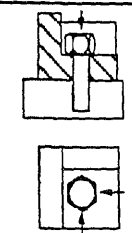
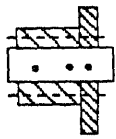
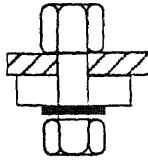
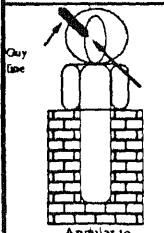
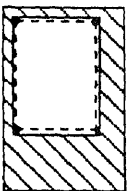
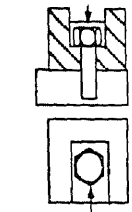
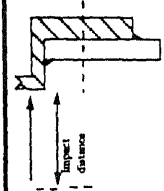
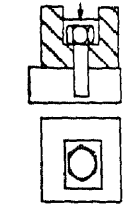
	DIRECTION OF SEPARATION FORCE <i>A</i>	FORCE MAPPING RATIO <i>B</i>	FASTENING ACCESSIBILITY <i>C</i>	APPLICATION OF THE FASTENER <i>D</i>	INTER FASTENER DISTANCE <i>E</i>	CONSTITUENT COMPONENTS <i>F</i>
1	 <p>Parallel to fastening axis</p>	 <p>$0 < \text{FMR} < 0.25$</p>	 <p>Accessible from five directions</p>	<p>Manual (least preload accuracy)</p>	 <p>Fixed distances in a pattern (regular pattern)</p>	 <p>One only. Like adbeaves, welds etc.</p>
2	 <p>Perpendicular to fastening axis</p>	 <p>$0.25 < \text{FMR} < 0.50$</p>	 <p>Accessible from four directions</p>	<p>Automatic with no features (consistent but inaccurate preload)</p>	 <p>Different distances in a pattern (irregular pattern)</p>	 <p>Two. Like the two parts in a snap fit assembly.</p>
3	 <p>Eccentric to fastening axis (resulting in significant turning moment)</p>	 <p>$0.50 < \text{FMR} < 0.75$</p>	 <p>Accessible from three directions</p>	<p>Automatic with preload features (most accurate but increase in accuracy leads to increase in cost)</p>	 <p>Distances in the fastener planes (when the planes are different)</p>	 <p>More than two like nut, bolt and washer</p>
4	 <p>Angular to fastening axis</p>	 <p>$0.75 < \text{FMR} < 100$</p>	 <p>Accessible from two directions</p>			
5	 <p>Impact force</p>		 <p>Accessible from one direction only</p>			

* Sectional elevation
Plan
Others.

Figure 3.1 Fastener classification and identification chart.

It is important to note that although the layout is in the form of a matrix the conceptual layout is based on group technology where the user need to obtain a code for each of the six categories by placing their design fasteners in a particular row or class in each category.

An example would be nut, bolt and washer assembly in a tire of car. Then the direction of separation is perpendicular to the axis, force mapping ration is between .75 to 1, Accessibility is from five directions, application is manual or power assisted, inter fastener distance is fixed and constituent components are three. Hence, the code for this particular fastener would be: $A_2B_4C_1E_1F_3$.

3.6 Classification of Positional Relationships from the DFQM Perspective.

In general there are only three possible positional relationships between two adjacent parts, these are:

1. Abutment
2. Insertion
3. Overlap

These conditions have multiple interpretations in everyday language. However, in our methodology the usage will be defined as follows:

1. *Abutments*: are conditions where two parts are in contact with each other at a surface which is dimensionally consistent on both parts. In other words, when two parts are in contact with surfaces of equal size, the prevalent positional relationship is called abutment.

2. *Insertion*: is when one part is inserted into another part. This condition is described by the possibility when all surfaces around any axis of the part are in contact with all the surfaces of another part about a coinciding axis on the other part.
3. *Overlaps*: When a proportion of any surface on one part meets either a proportion of or the whole surface on another part then the condition is described as an overlap.

In all the three possibilities, the condition of structural support has to be identified. This supporting structure is described as a 'base'. There are three conditions of base support, they are:

1. *Common Base*: In this case both the parts obtain structural support from the same source.
2. *Horizontal Independent Base*: In this case although both the parts have different base supports, the longitudinal axes of both the parts are parallel.
3. *Vertical Independent Base*: In this case although both the parts have different base supports, the longitudinal axes of both the parts are perpendicular.

Locators are another important factor which influence positional relationships. They may be an incorporation into the shape of the parts or they may be external. They may also be coincidental. The conditions of fully locating or partially locating depending upon the number of directions of movement restricted are utilized to classify these relationships.

3.7 The Positional Relationship Chart

This chart, shown in figure 3.2 attempts to classify the positional relationship between various design pairs using the concept of a supporting base in conjunction with the type

DFQM CLASSIFICATION OF POSITIONAL RELATIONSHIPS.								
	ABUTMENTS	INSERTION	OVERLAPS					
			With Locators		Self locating		Without locators	
			Fully located	Partially located	Fully located	Partially located		
	1	2	3	4	5	6	7	
COMMON BASE								
INDEPENDENT BASE	Horizontal							
	Vertical							NA

Note: The 'base' means the supporting structure. If the parts have different supports then they are independent base parts and if they share the same support then they are common base. Eg a pulley and it's shaft are independent base because the shaft is supported by bearings and the pulley is supported by the shaft.

Figure3.2 Positional relationship classification and identification chart

of relationship in terms of insertion, abutments or overlaps. These have been explained for use in this methodology previously. Using the established nomenclature the user is expected to identify the kind of relationship from the columns which have been numbered 1 through 7 and the base condition from the rows which have been represented by the letters A, B and C.

This allows the user to put each design relationship in a particular class with particular base condition and a type of relationship. To illustrate, consider the installation of a rectangular cover on a consumer appliance figure 3.2.1. The cover needs to be installed on a rectangular box with four screws at the four corners. The cover has a step cut on all its four edges corresponding to a similar step cut on the edges of the walls of the receptacle box. The cover is inserted on the box hence the type of relationship is insertion and can therefore be placed interference the column entitled '2'. Since the base support is independent in the sense that the box provides structural support to the cover and both do not share a common base the row entitled Independent Base - Horizontal ('B') can be selected. Thus, the parts are clearly identifiable by the class 2-B.

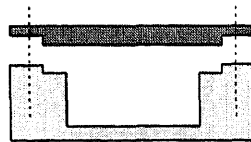

Figure 3.2.1 Installation of cover on a box as an illustration for positional relationships.

3.8 Classification of Functional Relationships from the DFQM Perspective.

Due to complexity of design and the multitasking approach followed by designers in their parts the analysis of the functional interaction between various parts can be a rather

difficult task. Due to the fact that functions carried out by one part in an assembly and also in each functional pairing can be numerous and complex we need to identify the functionality as it is relevant in our analysis.

We identified that functions are basically of two broad types. A part is either supportive/retentive in nature like pillars or holding plates etc., or cosmetic/protective like covering structures on rotating members. Basically the former has a contributing effect towards the overall functionality of the assembly and in the latter has a functionality which is contingent or external to the functionality of the assembly. However, this is true only in static assemblies like tables and chairs or even in static pairs of parts in otherwise dynamic assemblies.

The conditions tend to differ, however, with the introduction of motion. Functionality has to be now identified in terms of the motion of the various components in an assembly. Identifying the types of motion as relative or congruent and separating the rotary from the linear in each case we are able to identify most cases of functional relationships. The functional relationships are also classified on the basis of the continuity of motion in the sense that whether it is continuous or non continuous.

The terms used above can be defined as :

1. *Relative motion*: This is the type of motion in which the two parts under consideration move relative to each other. Linearly it may be illustrated by a piston and its chamber for continuous motion. For non continuous motion it can be adequately represented by the shock absorbers in an automobile. In rotary motion it is illustrated by a Geneva mechanism for non continuity and a shaft and a bearing for continuity.
2. *Congruent motion*: This is the type of motion in which the two mating parts move in congruence without any relative motion to produce a motive functionality which is

DFQM CLASSIFICATION OF FUNCTIONAL RELATIONSHIPS

		SUPPORT/RETENTIVE 1	COSMETIC/PROTECTIVE 2
NO MOTION A		<p>Fig. a S/R Element G</p> <p>Fig. b F G</p>	<p>C/P Element</p>
CONGRUENT MOTION B	LINEAR	<p>F</p>	<p>F</p>
	ROTARY	<p>Pulley Churner Belt F</p>	<p>F</p>
RELATIVE MOTION D	LINEAR	<p>F F</p> <p>Hydraulic support eg. shock absorbers</p>	<p>F</p>
	ROTARY	<p>Geneva Mechanism</p>	<p>Front view Bearing & shaft.</p>

Figure 3.3 Functional relationship charts.

somehow utilized in the assembly. Linearly it can be illustrated by a ball ended shaft moving in it's guide for non-continuous motion and by the piston rod and the piston for continuous motion. For rotary motion, non continuous motion is represented by a pulley and an attached churner and continuous by a shaft and a pulley.

3.9 The Functional Relationship Chart

The functional relationship chart is shown in figure 3.3. The representative figures have been explained earlier. The classification inherently differs between moving part and non-moving part pairs. Hence the chart is two part in nature. The first part tends to identify the functional relationship between two parts which are not moving. The second part on the other hand tries to identify the functional relationships between parts which are moving. Now we take the type of motion along the rows. Thus the first table and in essence the first row of the table here identified by A identifies the condition of 'No Motion' and the columns represent the two possibilities under this category namely, Support/Retentive and Cosmetic/Protective. These have been explained earlier and are identified as '1' and '2' respectively.

In the second part, the two major categories are Congruent and Relative motion. These are further subdivided into rotary and linear categories. These rows are identified as B,C,D and E. The columns are identified as N1 and N2 to differentiate them from the column numbers 1 and 2 of the first part. These identify Non Continuous and Continuous motion respectively. An illustration may be the retainer spring in a ball point pen and the refill. The spring moves relative to the refill hence it is relative motion, it is linear and it

occurs only at the initiation and end of the pens' use it is non continuous. The category for this pair is identified as 'D-N1'.

CHAPTER 4

DFQM ANALYSIS OF FASTENER RELATED PROBLEMS

4.1 The Role of Fasteners in Quality Manufacturability

Industries in the U.S use more than 200 billion fasteners each year. The problems associated with ‘bad bolts’ have a very crippling effect on the viability of the product since the fasteners are in essence holding together the assembly. Hence, the problems associated with fasteners become very obvious in a short span of time. With the passing of the Fastener Quality Act (PL 101-592) defects in the production of fasteners themselves have been somewhat regulated, incorrect use of fasteners and/or defective assembly of fasteners still plague otherwise apparently ‘good’ designs.

Fasteners manufactured and tested to all standards can still cause problems if not installed properly. The preload is a major determinant in the performance of a fastener. Misalignment, unchamfered holes etc. are the major physical errors which create one of the three defects listed later. The installation of the fasteners also determines the nature of forces acting on the fastener and thus the performance and ultimately the quality of the assembly.

The installation of the fasteners controls the quality of the product, thus the fasteners deserve a very detailed analysis in any situation where the manufactured quality of a product is being discussed. In an earlier analysis Das (1992) has identified such problems hereby called ‘specific defects’ and catalogued them as follows:

1. Loose or ill-fitting Fasteners

2. Overtightening of Fasteners

3. Fracture or Failure

We needed to analyze the quality of a product upon manufacture from the perspective that if one of the aforementioned specific defects occur then what compendium of parameters or factor variables catalyze their occurrence. In this chapter this analysis has been explained and the methodology used is also explained. The analysis is carried out with the help of a methodology similar to decision trees.

4.2 The DFQM Scheme and Mechanism

Das S. K has identified a macro approach for identification and improvement of the quality issues in assembled products. Under this scheme the defects have been classified into ‘Defect Classes’ which are a compendium of specific errors known as ‘Specific Defects’. These specific defects are in turn caused due to the presence of one or more ‘Factor Variables’ which are the design parameters selected. These specific conditions which catalyze the presence of factor variables into tangible and specific defects are known as ‘Error Catalysts’. The factor variables have been classified into groups or classes known as ‘Influencing Factors’. This scheme has been illustrated in a schematic diagram shown in appendix B.

Although the error catalysts cause the specific defects to occur the probability of occurrence of the error catalysts depends upon the factor variables present. This is evident by the fact that the design parameters are variable and it is the particular interaction that causes the specific defect that we are interested in. This interaction needed to be catalogued and the methodology followed in this work is based on decision trees.

Therefore error catalyts were identified and then the analysis was performed using decision trees by using a deviation hereby referred to as ‘Catalysis Graphs’.

4.3 The Composition of Error Catalyts

Since factor variables, as the nomenclature indicates are variable quantities, different permutations of their values causes different specific defects or causes the likelihood of the occurrence of specific defects to change. Also, the same specific defect may be caused by different error catalyts. In order to analyze this complex situation we analyzed each specific defect for it’s various error catalyts.

This analysis needed a decision tool which could drive the analysis. An approach based on decision trees was decided upon and followed. Thus the catalysis graphs were created. These help in finding out for a given design with its factor variables, the likelihood that the error catalyts under study will cause that particular defect.

As a part of this project, catalysis graph sheets were prepared for each error catalyts under each specific defect. The purpose of preparing these sheets was to summarize the description of each error catalyts and simplify the catalysis process into decision graphs. Since this thesis is part of an ongoing research, the format used for error catalysis sheets not only provides consistency, but also helps as an easy reference for other areas of the research. They will be of utmost important in the final stages of this project during the compilation phase. The analysis is driven from the initial steps of identifying all error catalyts that can cause any specific defect and consequently developing catalysis graphs for them.

All factor variables were also identified or quantified using metrics that shall be followed consistently for the entire DFQM analysis. Table 4.1 gives metrics that are used for other factor variables.

Table 4.1 Metrics Involved in Quantification of Factor variables

	FACTOR VARIABLES	MEASUREMENT or IDENTIFICATION SCHEME
1	Shape and Symmetry	DFQM Classification of Parts by Symmetry and Geometry (Appendix A)
2	Mating Features	Number of Mating Surfaces and Number of Mating Parts
3	Coefficient of Thermal Expansion	Ratio of Coefficients of Two mating Parts
4	Hardness	Hardness Number Ranges
5	Stress Properties	Ranges of Traditional Strength Measuring Units
6	Assembly Fixturing Method	Automatic, Manual, or Robotic Assembly
7	Assembly Sequence	Chronological
8	Functional and Motion Relationship	DFQM Classification of Functional Relationships (Figure 3.3)
9	Fitting Relationship	Press Fit, Loose Fit, and Running Fit
10	Positional Relationship	Positional Relationship Chart (Figure 3.2)
11	Fastening Sequence	Sequence
12	Fastening Type, Strength	Fastener Classification and Identification Chart (Figure 3.1)

4.4 The Quality Manufacturability Analysis

The Quality Manufacturability (QM) analysis has been explained in detail by Tamboo (1994) in his thesis. In order to present a brief overview a small discussion is provided.

The analysis results in a matrix of values called the Quality Manufacturability Matrix (QMM). This matrix is indicative of the relative likelihoods of the various defect classes. Figure 4.1 shows the format for the QMM.

	Misplaced or Missing parts	Part Misalignment	Part Interferences	Fastener Problems	Total Nonconformity	Damaged Parts
Part 1						
Part 2						
Part 3						
Part 4						

Figure 4.1 Format for the Quality Manufacturability Matrix (QMM).

A composite score is also obtained from this matrix which is the designated 'Design for Quality Manufacturability Index' (DFQM Index). For comparison of alternatives and changed designs this index can be effectively utilized. However, in conditions where when a design is under improvement a designer needs to identify areas which require the most detailed analysis. These are identified from the matrix, where the defect with the most relative occurrence can be tackled first for purposes of improvement efforts. The nomenclature for calculations has been established as:

CD - Class of Defects

SD - Specific Defect

EC - Error Catalyst

k - Defect Classes

$S_{d_{jk}}$ - Specific Defect 'j' belonging to Defect Class 'k'

EC_{ijk} - Error Catalyst 'i' affecting Specific Defect 'j' which belongs to Defect Class 'k'.

M_k - Number of SD belonging to DC_k

N_{jk} - Number of EC affecting SD_{jk}

p - 1.....p

S_{ijk} - Score for EC_i influencing SD_{jk}

W_{ijk} - Weightage on S_{ij} based on importance of EC_{ijk} for SD_{jk}

Q_{jk} - QM score for each SD_j under CD_k

F_{jk} - Multiplication factor for Q_{jk} based on relative importance of SD_j belonging to CD_k

C_k - QM score for each Cd_k

The equations used in the analysis are

$$Q_{jk} = \frac{\sum_{i=1}^n S_{ijk} * W_{ijk}}{N_{jk}} \quad (4.1)$$

$$(4.2) \quad C_k = \frac{\sum_{j=1}^n Q_{jk} * F_{jk}}{M_k}$$

The equation 4.1 is used to determine the QM score for each specific defect and equation 4.2 provides the QM score for the defect class.

4.5 Analysis of Fastener Related Problems

4.5.1 Loose or Ill Fitting Fasteners

Loose or ill-fitting fasteners from the manufacturing perspective are caused only if some external agent causes the fasteners to either loosen or become ill-fitting during assembly or causes the fasteners to be installed loose. Such improperly installed fasteners in addition to being aesthetic imperfections could seriously affect the functionality of the assembly. This is possibly one of the most commonly noticed defects in assembled products. The influencing factors which can contribute most to this kind of a defect are the type and method of fastening the material properties of component parts. The possibility of improper fastening equipment plays a critical part in the existence of this defect. Figures 4.3 through 4.4 show the catalysis graphs for the three error catalysts that influence this defect.

Three independent error catalysts are identified as the ones which influence the fasteners to be loose or ill-fitting. They are:

1. Loose fasteners due to thermal expansion and contraction - D11
2. Reduced area mapped causes heavy parts to loosen fasteners - D12
3. Many standard sizes cause automatic fastenings to lose accuracy - D13

Analyzing these error catalysts with respect to each other a matrix is created with relative weightage to each other. This matrix in this case has been illustrated in figure 4.6.

	D11	D12	D13	Row products
D11	1	.5	.66	0.33
D12	2	1	1.33	2.66
D13	1.5	.75	1	1.13

Figure 4.6 Relative weightage of error catalysts for loose or ill-fitting fasteners

ERROR CATALYSIS SHEET

DEFECT CLASS Fastner related problems	SPECIFIC DEFECT Loose or Ill-Fitting	SHEET NO: D11
ERROR CATALYST Loose fasteners due to thermal expansion and contraction.		
DESCRIPTION <p>Due to the fact that in some assemblies, different materials are fastened together under conditions of high temperature, differential expansion occurs. This is due to varying coefficients of expansion. The ratios of the coefficients of expansion are evaluated to check whether the factor is critical. If the factor is determined to be critical, then a continuation along the decision tree is required. If the factor is not critical, then a value of '0' is assigned. In cases where the ratio is significant, the type of fastener used is evaluated to see whether it can be classified as removable, semi-permanent, or permanent; only removable or semi-permanent fasteners can become loose or ill-fitting. Permanent fasteners receive a rating of '0'. Other fasteners receive a rating of '0' for preload corrected automatic fastening, and remaining information is evaluated from the table.</p>		
CATALYSIS GRAPH <pre> graph TD Start[START ANALYSIS] --> Ratios[Ratios of The Coefficient of Expansion] Ratios -- "> 2" --> Type[Type of Fastening] Ratios -- "1 to 2" --> Zero1((0)) Type -- Permanent --> Zero2((0)) Type -- Removable --> Method[Method of Fastening] Type -- Semi-permanent --> Method Method -- Automatic with Preload Accuracy --> Table1[Table] Method -- Manual --> Table1 Method -- Automatic without Preload Accuracy --> Table2[Table] Table1 -- C1, C2 --> Zero3((0)) Table1 -- C3 --> Zero4((0.3)) Table1 -- C5 --> One1((1)) Table2 -- F3 --> One2((1)) Table2 -- F1, F2 --> Zero5((0)) </pre> <p>(More components can cause missing or ill-fitting components which will leave the fastening loose.)</p>		

Figure 4.3 Catalysis graph for thermal expansion and contraction

ERROR CATALYSIS SHEET

DEFECT CLASS Fastener related problems	SPECIFIC DEFECT Loose or Ill-Fitting	SHEET NO: D12
ERROR CATALYST Reduced area mapped may allow heavy parts to loosen fasteners.		
DESCRIPTION If the area mapped (see figure) is small and the preload acting on the fasteners is not accurate, heavy parts tend to exert a couple on the fasteners causing them to loosen or fit improperly. Using the fastener classification table, the small area mapped is evaluated and depending upon the type of fastening used, a value of between '0' and '1' is assigned; '0' if the error catalyst doesn't act and '1' where it does completely. This happens only in removable or semi-permanent fasteners.		

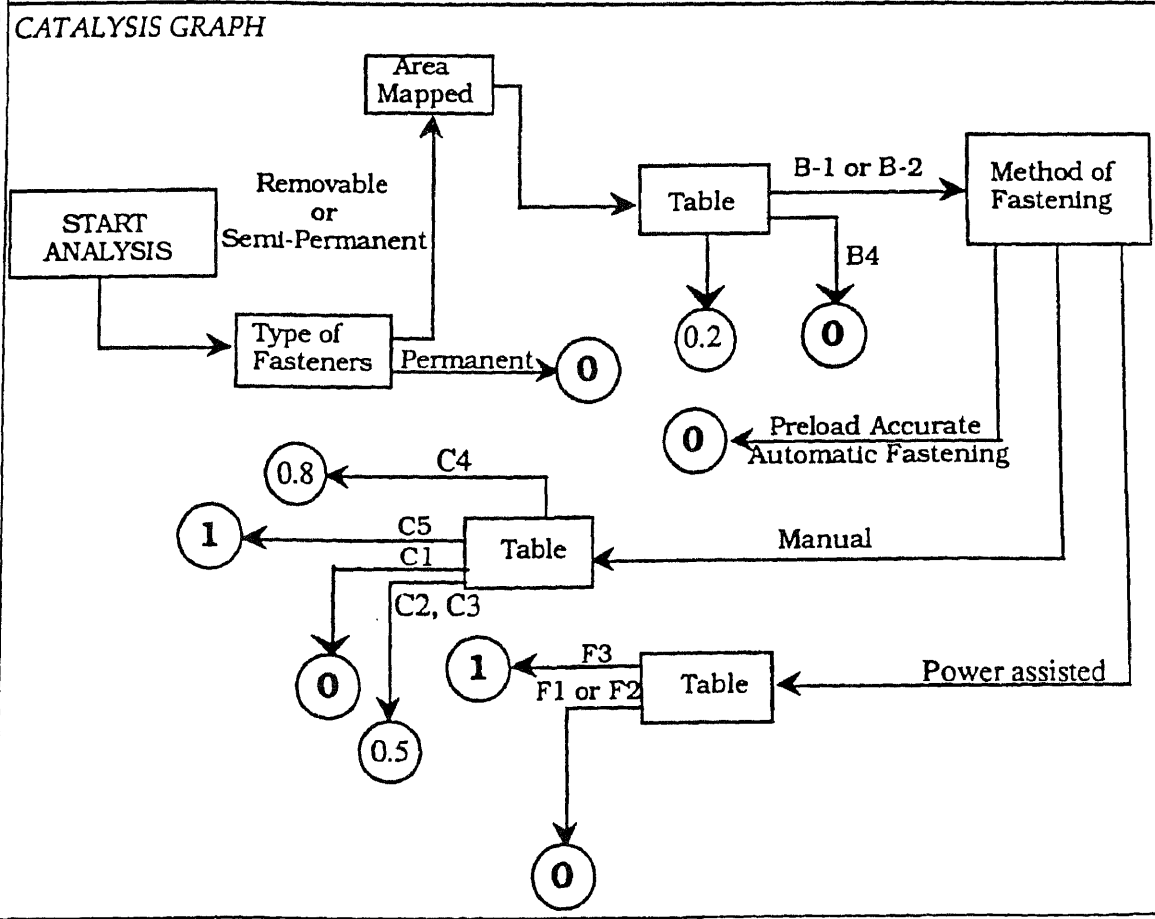
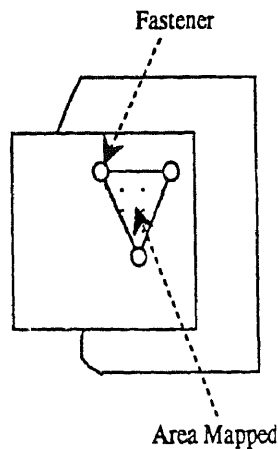

Figure 4.4 Catalysis graph based on reduced area

ERROR CATALYSIS SHEET

DEFECT CLASS Fastner related problems	SPECIFIC DEFECT Loose or Ill-Fitting	SHEET NO: D13
ERROR CATALYST Too many standard sizes causes automatic fastenings to lose accuracy.		
DESCRIPTION If there are more than 5 sizes of removable or semi-permanent fasteners used in an assembly, then in fasteners with more than 3 components and automatic fastening without preload accuracy (as in power tools), can cause loose or ill-fitting fasteners. These receive a rating of '1'. Also, fasteners which are difficult to access may have loose fasteners if they are fastened manually. Regardless of the number of sizes of fasteners being used, they are given a rating of '1'.		
CATALYSIS GRAPH 		

Figure 4.5 Catalysis graph for too many standard sizes

Most instances of loose or ill-fitting fasteners occur because a couple is acting on the two parts to be fastened thus causing the part to exert a shear force on the joint and consequently cause the fastener at the joint to be loose or ill-fitting during assembly. Some cases are also noticed where multiple sizes of fasteners in the same product assembly causes the equipment to undergo a hysteresis error due to frequent changes in calibration. Also, the possibility of human error also increases a lot. In assemblies where high temperature are part of the assembly process, differential expansion can cause the problem.

The product of the matrix rows provides us with the relative weights of all the factors being compared. If we normalize the values to '1', the relative weightages of the three error catalysts are given as follows:

$$D_{11} = 0.125; \quad D_{12} = 1.00; \quad D_{13} = 0.42$$

Using equation 4.1, the QM score for the specific defect 'Loose or ill-fitting parts' is given as:

$$Q_{ID} = \frac{(0.125 * S_{11D}) + S_{21D} + (0.425 * S_{31D})}{3}$$

where S_{11D} , S_{21D} and S_{31D} are the scores for the three error catalysts.

4.5.2 Overtightening

Two inter-related characteristics keep tightened screw assemblies from coming apart: spring tension, or screw stretch to obtain this tension, and frictional resistance. A tightened screw can be likened to a coiled spring in tension. The screw can be tightened and loosened any number of times and, as long as the tension in the screw does not

exceed the elastic limit, the screw will act like a spring. This spring action is what causes the fastener to hold two components together but unfortunately it is also the reason why fasteners can be improperly installed.

In order to avoid the first kind of specific defect, loose fasteners; operators sometimes have the tendency to overtighten fasteners. Thus, most often than not this kind of an error occurs in fastenings by human operators either manually or with power assisted tools. The presence of features like stress fasteners, sequenced fastening and the constituent components dictate this kind of an error. The catalysis graphs for this specific defect are shown in figure 4.8 and 4.9.

Two error catalysts have been identified for this type of a specific defect. These are:

1. Overtightening due to fastener type and application method. D21
2. Overtightening due to wrong sequence of tightening or external stress. D22

These error catalysts are analyzed in pairs in figure 4.11 by using the same matrix technique shown earlier and normalized to 1 to get the relative weights.

	D21	D22	Row products
D21	1	.5	0.5
D22	2	1	2

Figure 4.7 Relative weightage of error catalysts for Overtightening

The scores thus obtained for the three error catalysts are:

$$D21 = 0.25$$

$$D22 = 1$$

Using the equation 4.1, the QM score for the specific defect 'Overtightening' is given as:

ERROR CATALYSIS SHEET

<i>DEFECT CLASS</i> Fastener related probs.	<i>SPECIFIC DEFECT</i> Overtightening	<i>SHEET NO:</i>
<i>ERROR CATALYST</i> Overtightening due to fastener type and application method.		D21
<i>DESCRIPTION</i> If the type of fastener is of two constituent components eg. a nut and a bolt then manual application or power tool assisted application can cause overtightening if the part is easy to access and tighten.		
<i>CATALYSIS GRAPH</i>		
<pre> graph TD Start[START ANALYSIS] --> Comp[Constituent components (fastener table)] Comp -- F1 --> C1((0.1)) Comp -- F2 --> App[Application of the fastener (fastener table)] App -- D3 --> D3((0)) App -- D2 --> D2((0.5)) App --> Acc[Fastening accessibility (fastener table)] Acc -- C1 --> C1_6((0.6)) Acc -- C2 --> C2_5((0.5)) Acc -- C3 --> C3_5((0.5)) Acc -- C4 --> C4_2((0.2)) Acc -- C5 --> C5_1((0.1)) </pre>		

Figure 4.8 Catalysis graph for fastener type and application

ERROR CATALYSIS SHEET

DEFECT CLASS Fastener related probs.	SPECIFIC DEFECT Overtightening	SHEET NO: D22
ERROR CATALYST Overtightening due to wrong sequence of tightening or external stress.		

DESCRIPTION

In many fastening situations if either the number of fasteners is less or no particular sequence has to be followed the presence of auxilliary stress devices can cause overtightening due to the fact that they may fail or may be missing or may be damaged. If the number of fasteners is large and the sequence is important then wrong sequence of tightening will cause overtightening.

CATALYSIS GRAPH

```

graph TD
    Start[START ANALYSIS] --> A["a = # of fasteners / # of mating surfaces"]
    A -- "a < 4" --> Comp["Constituent components (Fastener table)"]
    A -- "a > 4" --> Seq["Is the sequence important?"]
    Comp -- "F3" --> Stress["Any auxillary stress devices like spring washers?"]
    Stress -- "No" --> C0((0))
    Stress -- "Yes" --> B["b = # of fasteners / # of stress devices"]
    B -- "0 to 0.25" --> C01((0.1))
    B -- "0.25 to 0.5" --> C03((0.3))
    B -- "0.5 to 0.75" --> C05((0.5))
    B -- "0.75 to 1" --> C07((0.7))
    Seq -- "No" --> C01
    Seq -- "Yes" --> C["c = # of fasteners in sequences / Total number of fasteners"]
    C -- "0.5 to 0.75" --> C08((0.8))
    C -- "0.75 to 1" --> C1((1))
    C -- "0 to 0.25" --> C01
    C -- "0.25 to 0.5" --> C05
    C01 -.-> Comp
  
```

Figure 4.9 Catalysis graph for stress variation

$$Q_{2D} = \frac{(0.25 * S_{12D}) + S_{22D}}{2}$$

where S_{12D} & S_{22D} are the scores obtained from the error catalysts.

This error catalyst is critical. This becomes evident from the fact that due to overtightening when the joint is stressed the high pre-tension and the fluctuating added stress, the part undergoes fatigue failure. This could seriously affect the functionality of the product. This error is often evident in fastenings made by amateurs like do it yourself kits and frequently loosened and tightened joints like bicycle axles. This kind of failure incidentally is the most common type of error in fasteners.

4.5.3 Fracture or Failure

Fasteners can fail due to a host of reasons. Tensile failure, fatigue failure, severe environments etc. can cause the fastener to fail. Fastener strength is expressed in terms of ultimate tensile strength. However, the relationship between yield and ultimate tensile strength varies depending upon the fastener material and strength.

A brief catalogue of reasons that fasteners fail from Fox and Grunor (1993) is given here.

- It is difficult to adjust clutches in power guns to the proper torque settings.
- Driving conditions and surface conditions of the mating parts vary greatly
- Power drivers may be improperly used to drive two or more different driver screws with the same torque settings.
- Losses or variations in the power source, air or electric, make accurate torque outputs impossible.

- Guns used are adequate to drive the screws but not powerful enough to tighten it to optimum tension.
- In some conditions, the optimum tension is actually detrimental to the mating parts.

It becomes obvious very quickly that most of these are assembly time errors and the designer can not possibly control the error. However, there are certain conditions where the design induces the fastener to fail. Consider the situation where the power tool is used in a restrictive condition where or visual or mechanical constraints cause the fastener to be driven to failure. Also, conditions where dislocating forces acting on the part during assembly are necessitated by the design the fasteners may fail. This can easily be accommodated by top down design.

Figures 4.10 and 4.11 illustrate the catalysis graphs for this type of an error. The error catalysts in this case have been catalogued as:

1. Failure due to the use of power tools in restrictive conditions. D31
2. Failure due to unnecessary dislocating assembly stress. D32

The comparative matrix for the error catalysts in this specific defect is shown in figure 4.12

	D31	D32	Row products
D31	1	2	2
D32	.5	1	0.5

Figure 4.12 Relative weightage of error catalysts for fracture or failure.

The normalized scores for the error catalysts thus are:

ERROR CATALYSIS SHEET

DEFECT CLASS Fastener related probs.	SPECIFIC DEFECT Fracture or failure	SHEET NO: D31
ERROR CATALYST Fracture due to the use of power tools in restrictive conditions		
DESCRIPTION If an operator cannot easily see the fastener at location and is using power assisted tightening then awkward angles, misdirected force or a host of other factors could cause fastener failure or even fracture.		
CATALYSIS GRAPH		

```

graph TD
    Start[START ANALYSIS] --> FA1[Fastening Accessibility Table]
    FA1 -- "C1, C2" --> N0((0))
    FA1 -- "Other" --> FA2[Fastener application table]
    FA2 -- "D3" --> N0
    FA2 -- "D1" --> N01((0.1))
    FA2 -- "D2" --> FA3[Fastening accessibility table]
    FA3 -- "C3, C4" --> N03((0.3))
    FA3 -- "C5, C6" --> Calc["# of fasteners in C5 or C6  
a = Total # of fasteners"]
    Calc -- "0.5 to 1" --> N1((1))
    Calc -- "0.25 to 0.5" --> N08((0.8))
    Calc -- "0 to 0.25" --> N05((0.5))
  
```

Figure 4.10 Catalysis graph for power tools

ERROR CATALYSIS SHEET

DEFECT CLASS Fastener related probs.	SPECIFIC DEFECT Fracture or failure	SHEET NO: D32
ERROR CATALYST Failure due to unnecessary dislocating stress during assembly		
DESCRIPTION If a fastener with low mapping area is subjected to an eccentric load during assembly it may fail due to unnecessary stress.		
		
CATALYSIS GRAPH		
		

Figure 4.11 Catalysis graph for dislocating stress

$$D31 = 1$$

$$D32 = .25$$

and using equation 4.1 the QM score for this specific defect is given as:

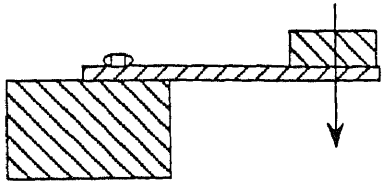
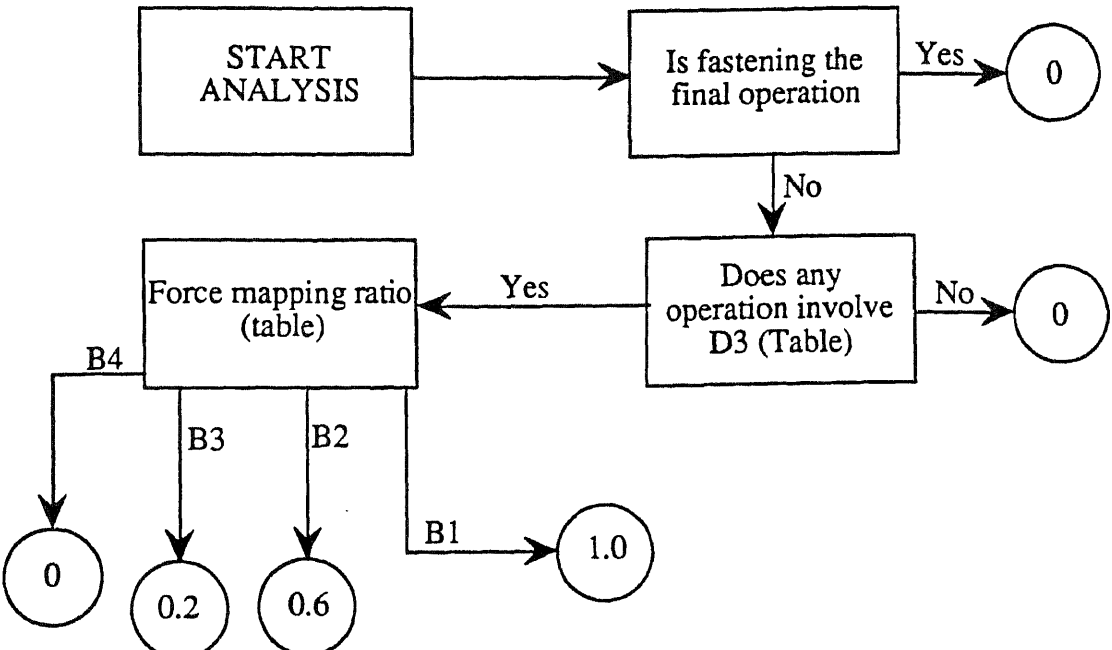
$$Q_{3D} = \frac{S_{13D} + (0.25 * S_{23D})}{2}$$

where S_{13D} & S_{23D} are the two scores from the catalysis graphs.

It is obvious that this type of error is the most easily noticed and manufacturing will get it corrected from design very soon but the time and capital lost in the redesign procedure is the basic commodity which DFM methodologies intend to save.

4.6 Results Based on the Analysis.

We need to get a cumulative score for the defect class using a technique very similar to the ones we used to analyze the error catalysts to get a QM score for the specific defect. Comparative analysis of the three specific defects is shown in figure 4.13

Sp. defects	D1	D2	D3	Row products
D1	1	1	2	2
D2	1	1	2	2
D3	0.5	0.5	1	0.25

Figure 4.13 Relative weightage of specific defects in the defect class fastener related problems.

Thus the normalized scores for the three specific defects are given as

$$D1 = 1$$

$$D2 = 1$$

$$D3 = .125$$

Using the equation 4.2, the score for the defect class is given as,

$$C_D = \frac{Q_{1D} + Q_{2D} + (0.125 * Q_{3D})}{3}$$

This score can be utilized to obtain a reading on the effect of this defect class on the QM of the assembly. Using comparative analysis, with scores of other classes for all constituent parts and subassemblies we can determine the area which needs most attention. This comparative analysis is carried out using the Quality Manufacturability Matrix (QMM) which has been shown earlier in figure 4.1. This matrix not only provides information regarding which defect class to concentrate upon but also guides the designer as to which part in the assembly to concentrate upon.

CHAPTER 5

DFQM Analysis of Misalignments

A very obvious symptom of bad manufacturing quality is misaligned parts. Although most quality problems which occur during manufacturing of a product are related to manufacturing errors, misalignments are very powerfully affected by design time decisions. Hence this kind of a defect deserves a very careful analysis in order that the designers using our methodology can identify and eliminate features which could possibly cause misalignments in the finished assembly.

5.1 Misalignments as a Manifestation of QM.

Misalignments are basically defined as improper positional relationships between two surfaces or parts. This can happen due to improper installation or bad design. From the perspective of DFQM, misalignments can be defined as the type of defects which occur when two related parts are not in alignment with each other, either functionally or aesthetically, as intended in the design. They have been classified by Das (1992) into the following four major categories: axial misalignment, radial misalignment, angular misalignment and linear misalignment. These misalignments have been illustrated in figure 5.1. Using this classification as a basis, we classify them as the four specific defects in the defect class of misalignments. They can be described as:

- i. *Axial misalignment*: which represents any displacement along the Y & Z axes.

ii. *Angular misalignment*: which represents any angular distortion along the Y & Z axes.

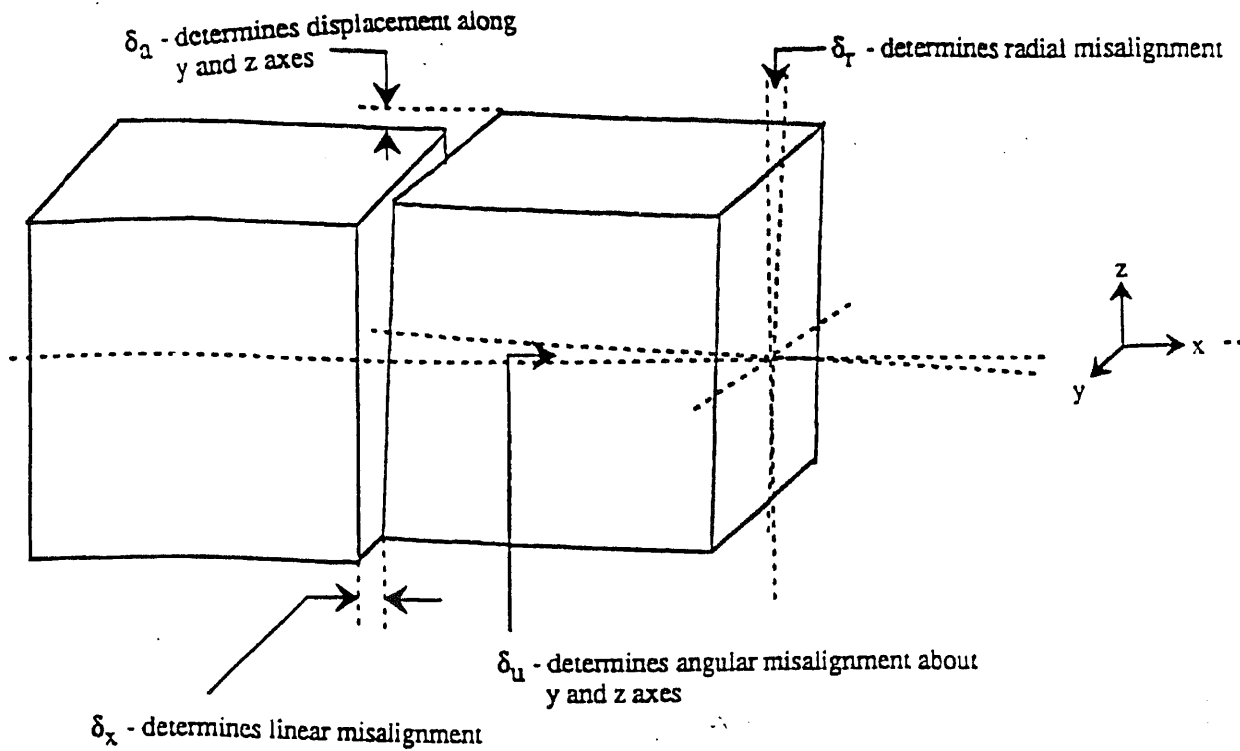

Figure 5.1 Conceptual diagram to illustrate misalignments.

iii. *Linear misalignment*: which represents any displacement along the X axis.

iv. *Radial misalignment*: which represents any angular distortion along the X axis.

These error catalysts have been rigorously analyzed and the corresponding descriptions and catalysis graphs are shown. These are analyzed using the same methods and equations used earlier on the fasteners. The catalysis graph for each of these specific defects also follow the same procedure.

5.2 Analysis of Misalignments

5.2.1 Axial Misalignments

This type of misalignment is what may be commonly referred to as shift or wrong placement and when two parts whose axes should be aligned but are out of alignment could be described as axially misaligned. It is a quite frequently encountered manufacturing anomaly and can be easily recognized but its analysis is slightly complicated. It could occur due to complicated shape of mating parts, thermal expansion, the selection of fasteners or a compendium of these factors. The error catalysts have been described along with their catalysis graphs in figures 5.3 through 5.5.

A rigorous analysis has been carried out and the error catalysts under this category have been identified as:

1. Inability to simultaneously align all mating features. B11.
2. Change in the axis alignment due to the differential thermal expansion. B12
3. The selection of an inappropriate fastener. B13.

These error catalysts have been analyzed in pairs in figures 5.2 and by using the same matrix technique shown in chapter 4 and normalized to 1 to get the relative weights.

	B11	B12	B13	Row products
B11	1	2	1.5	3
B12	.5	1	1.33	.665
B13	.66	.75	1	.496

Figure 5.2 Relative weightage of error catalysts for axial misalignment

ERROR CATALYSIS SHEET

DEFECT CLASS Misalignments	SPECIFIC DEFECT Axial Misalignment	SHEET NO: B11
ERROR CATALYST Inability to simultaneously align all mating features.		
DESCRIPTION <p>In this error catalyst the decisive factor is the "mating features". The mating features are measured in terms of the ratio between the mating surfaces and the mating parts. If the number of mating surfaces is large and the positional relationship cannot be clearly defined either by positioning elements like pegs etc. or by the use of fasteners then we see that there is a large probability that the axes of the two parts do not align properly during assembly thus causing axial misalignment. In this misalignment the direction of mating and the direction of fastening is also important.</p>		
CATALYSIS GRAPH <pre> graph TD Start[START ANALYSIS] --> Box1["Number of mating surfaces Number of mating parts"] Box1 -- "1 to 2" --> Box2["Number of constraints resisting motion in the plane of the mating surfaces"] Box1 -- "2 to 5" --> C1((0.8)) Box1 -- ">5" --> C2((1.0)) Box2 -- ">=1" --> C3((0)) Box2 -- "<1" --> Box3[Are there fasteners in all the mating directions] Box3 -- Yes --> C4((0)) Box3 -- No --> C5((1)) Box1 -- "<1" --> Box4[Number of fasteners or positioning elements] Box4 -- "=0" --> C6((1)) Box4 -- ">0" --> C7((0)) </pre>		

Figure 5.3 Inability to simultaneously align all mating features

ERROR CATALYSIS SHEET

DEFECT CLASS Misalignments	SPECIFIC DEFECT Axial Misalignment	SHEET NO: B12
ERROR CATALYST Change in the axis alignment due to the differential expansion		
DESCRIPTION <p>In the second error catalyst, the most significant factor is the coefficient of expansion of the materials. The ratio of the coefficients of expansion provides the primary criterion for evaluation in the second decision table. If <i>all</i> the ratios are around $1 +$ or -0.2, then they are directly given a rating of '0'. This is because the differential between the coefficients of expansion does not cause the axes to have relative movement or undergo axial misalignments. If <i>all</i> the ratios are outside this range, a rating of '1' is assigned, as the cumulative effects may cause the parts to move relative to one another at various locations, causing axial misalignments. If all the ratios are not outside this range, the point at which heating occurs is considered; if it is prior to assembly, axial misalignment can occur due to displaced axial locations--a rating of '1' is given. Otherwise, if the parts have fasteners or other positioning elements, a rating of '0' is assigned; if not, it is '1'.</p>		
CATALYSIS GRAPH		
<pre> graph TD Start([START ANALYSIS]) --> Ratios[Ratios of Coefficient of Expansion] Ratios -- "All in 1 +/- 0.2" --> R0((0)) Ratios -- "Some Within 1 +/- 0.2 And Some Without" --> Heating[Time of Heating] Heating -- "Prior to assembly" --> R1((1)) Heating -- "Post assembly" --> Clearance{ Does the mating site or fastening location have clearance } Clearance -- "Yes" --> R1_2((1)) Clearance -- "No" --> R0_2((0)) Ratios -- "all outside 1 +/- 0.2" --> Clearance Clearance -- "Yes" --> R0_3((0)) Clearance -- "No" --> R1_3((1)) </pre>		

Figure 5.4 Effects of thermal expansion

ERROR CATALYSIS SHEET

DEFECT CLASS Misalignment	SPECIFIC DEFECT Axial misalignment	SHEET NO: B13
ERROR CATALYST The selection of fasteners influences the axial alignment		
DESCRIPTION <p>In the third error catalyst the most important factor causing the specific defect is the fastener characteristic. We have already made a table for the classification of the fasteners. We use that table and identify the classes that have the potential of causing axial misalignment. Any design which has fasteners lying in these classes will get a rating of '1' for this error catalyst; all others get a rating of '0'. The classes that have been identified for this error catalyst are:</p> <p style="text-align: center;">A2,B1,C1to5,D1to3,E1to3,F1to3 A4,B1,C1to5,D1to3,E1to3,F1to3</p> <p>These classes are justified as follows; in the 'A' column the direction of separating forces is evaluated. We understand that the axial misalignment can only occur if the force is either perpendicular or angular to the fastening axis, hence the classes A2 and A4 are identified. We also notice that axial misalignment is only supported by the lowest possible surface area mapped by the fasteners thus giving us the class B1.</p>		
CATALYSIS GRAPH <pre> graph TD Start[START ANALYSIS] --> Design[Fasteners In The Design] Design -- Table --> Decision{Do Any Of Them Belong To Either A2, B1, C1-5, D1-3, E1-3, F1-3, or A4, B1, C1-5, D1-3, E1-3, F1} Decision -- Yes --> Zero((0)) Decision -- No --> One((1)) </pre>		

Figure 5.5 Fastener effects

The scores thus obtained for the three error catalysts are:

$$B_{11} = 1$$

$$B_{12} = 0.221$$

$$B_{13} = 0.165$$

Using the equation 4.1, the QM score for the specific defect 'Axial Misalignment' can be given as:

$$Q_{1B} = \frac{S_{11B} + (.221 * S_{21B}) + (0.425 * S_{31B})}{3}$$

where S_{11B} , S_{21B} and S_{31B} are the scores for the three error catalysts.

This type of defect is noticed in what we describe as poorly manufactured or 'cheap' products. The defect is easily apparent in aesthetic terms however, more importantly, it can seriously affect the intended functionality of the product and thus compromising the performance of the product.

5.2.2 Radial Misalignment

This type of defect can be described in common parlance as 'twist' or 'torsion'. It is a defect which is specific to asymmetric or α symmetric parts. That means to say that if parts are β symmetric they cannot be radially misaligned. This is easily explained due to the fact that rotation does not affect the capability of the β symmetric to effectively mate with it's analogous part.

A small oversight by the design team of not providing any sort of reference for the person assembling the component to verify the position of the part can cause the part to be frequently misaligned. Dials on instruments could be facing away from the intended

ERROR CATALYSIS SHEET

DEFECT CLASS Misalignment	SPECIFIC DEFECT Radial misalignment	SHEET NO: B21
ERROR CATALYST Influence of symmetrical considerations on radial misalignments.		
DESCRIPTION		
<p>The most important feature in this error catalyst is symmetry. If all parts are β symmetric, any radial misalignment is ineffective functionally, and the error catalyst gets a value of '0'. If the part is a mix of α and β symmetric parts, we check to see if any of the parts are fixed to a base; if all α symmetric parts are fixed, then the error catalyst gets a value of '0'.</p> <p>In the case that there are no β symmetric parts in the assembly or the β symmetric parts are fixed to a base, then the ratio between the mating surfaces per mating parts is checked. A large ratio (any value >2) signifies a large probability of misalignment, radial or otherwise, and the error catalyst receives a value of '1'. Otherwise, if the ratio is <1, the presence of positioning elements provides a value of '0', and their absence a value of '1'. If the ratio possesses a value between 1 and 2, then the absence of eccentric weight provides a value of 0 and in the alternative case constraints, fasteners determine the value.</p>		
CATALYSIS GRAPH		
<pre> graph TD Start[START ANALYSIS] --> Symmetry[Symmetry of the parts] Symmetry -- "All β symmetric" --> 0_1((0)) Symmetry -- "Some β symmetric and others α or non-symmetric" --> Fixed[The part which is fixed or resists motion] Fixed -- "α symmetric or both" --> 0_2((0)) Fixed -- "β symmetric" --> 1_1((1)) 1_1 -- ">3" --> Ratio[Number of mating surfaces / Number of mating parts] Symmetry -- "Both α or non-symmetric" --> Ratio Ratio -- ">0" --> 0_3((0)) Ratio -- "2-3" --> 0_4((0.8)) Ratio -- "1 to 2" --> Weight[Does the weight of one of the parts act at an eccentric to the mating axis] Ratio -- "<1" --> Pos[Number of positioning elements, constraints or fasteners] Weight -- "No" --> 0_5((0)) Weight -- "Yes" --> Pos Pos -- ">0" --> 0_6((0)) Pos -- "<0" --> 1_2((1)) Pos -- ">1" --> 0_7((0)) Pos -- "<1" --> Fast[Does the fastening system hold position] Fast -- "Yes" --> 0_8((0)) Fast -- "No" --> 1_3((1)) </pre>		

Figure 5.6 Symmetrical influences

ERROR CATALYSIS SHEET

DEFECT CLASS Misalignment	SPECIFIC DEFECT Radial Misalignment	SHEET NO: B22
ERROR CATALYST Misalignment caused by thermal expansion.		
DESCRIPTION <p>In the second error catalyst, the most significant factor is the coefficient of expansion of the materials. The ratio of the coefficients of expansion provides the primary criterion for evaluation in the second decision table. If <i>all</i> the ratios are around $1 +$ or -0.2, then they are directly given a rating of '0'. This is because the differential between the coefficients of expansion does not cause the axes to have relative movement or undergo axial misalignments. If <i>all</i> the ratios are outside this range, a rating of '1' is assigned, as the cumulative effects may cause the parts to move relative to one another at various locations, causing axial misalignments. If all the ratios are not outside this range, the point at which heating occurs is considered; if it is prior to assembly, axial misalignment can occur due to displaced axial locations--a rating of '1' is given. Otherwise, if the parts have fasteners or other positioning elements, a rating of '0' is assigned; if not, it is '1'.</p>		
CATALYSIS GRAPH <pre> graph TD Start[START ANALYSIS] --> Ratios[Ratios of Coefficient of Expansion] Ratios -- "All in 1 +/- 0.2" --> R0((0)) Ratios -- "Some Within 1 +/- 0.2 And Some Without" --> Heating[Time of Heating] Ratios -- "all outside 1 +/- 0.2" --> Clearance[Does the mating site or fastening location have clearance] Heating -- "Prior to assembly" --> R1((1)) Heating -- "Post assembly" --> Fasteners[Do the parts have fasteners and/or positioning elements] Clearance -- "Yes" --> R1_2((1)) Clearance -- "No" --> R0_2((0)) Fasteners -- "Yes" --> R0_3((0)) Fasteners -- "No" --> R1_3((1)) </pre>		

Figure 5.7 Thermal effects

ERROR CATALYSIS SHEET

DEFECT CLASS Misalignment	SPECIFIC DEFECT Radial Misalignment	SHEET NO: B23
ERROR CATALYST Fastener induced misalignment.		
DESCRIPTION <p>Using the fastener table we realise that this type of misalignment can only be induced if the following type of fasteners exist in the assembly :</p> <ul style="list-style-type: none"> the separation force is perpendicular to the fastener axis(A2). the separation is parallel to the mating axis(A1). the force mapping ratio(FMR) < 0.25.(B1) the constituent components are > 2 (F2 or F3) <p>All possible combinations with A1 or A2 and B1 are possible error catalysts; the order would be</p> <ul style="list-style-type: none"> A2, B1, C(1 to 5), D(1 to 3), E(1 to 3), F(2 to 3) A1, B1, C(1 to 5), D(1 to 3), E(1 to 3), F(2 to 3) 		
CATALYSIS GRAPH		
<pre> graph TD Start[START ANALYSIS] --> Design[The Fasteners In The Design] Design -- Table --> Decision[Some Of The Fasteners Are In The Category Of Codes A2 B1 C1-5 D 1-3 E 1-3 F2-3 A1 B1 C1-5 D1-3 E1-3 F2-3] Decision -- Yes --> One((1)) Decision -- No --> Zero((0)) </pre>		

Figure 5.8 Fastener effects

user if this misalignment were to be left unchecked in the assembly of that particular instrument.

his defect can be caused by a complicated series of events which could involve the symmetry or the lack thereof in the shape of the mating components, thermal expansion or contraction or even selection of the wrong fastener. This defect has been analyzed and the error catalysts have been identified and catalogued along with their catalysis graphs in figures 5.6 through 5.8 and they are:

1. Influence of symmetrical considerations. B21
2. Misalignment caused by thermal expansion. B22
3. Fastener induced misalignment. B23

The pairwise comparison matrix is shown in figure 5.9.

	B21	B22	B23	Row products
B21	1	2	1.5	3
B22	.5	1	1.33	.665
B23	.66	.75	1	.496

Figure 5.9 Relative weightage of error catalysts for angular misalignment

The normalized scores thus obtained for the three error catalysts are:

$$B21 = 1$$

$$B22 = 0.221$$

$$B23 = 0.165$$

Using the equation 4.1, the QM score for the specific defect 'Radial Misalignment' can be given as:

$$Q_{2B} = \frac{S_{12B} + (.221 * S_{22B}) + (0.425 * S_{32B})}{3}$$

where S_{B21} , S_{B22} and S_{B23} are the scores for the three error catalysts.

This defect is very frequently encountered and is ironically the easiest to correct. It involves careful shape and symmetry design in the component parts in any assembly. It also involves positional verification with the design of locators as a part of the components or auxiliary to the components. It is frequently noticed in operations involving a shaft and hole kind of a relationship between the components.

Although intuition leads us to believe that this defect should occur most of the time in surfaces involving cylindrical primitives it is quite common in other shapes also.

5.2.3 Angular Misalignment

Improper fits, assembly of poorly finished components or surface distortion can cause the axis of a component to sustain angular deviation which is known as 'Angular Misalignment' in DFQM terminology. A very common example of this could be the connecting or transmission rod between two moving parts. If such a part is angularly misaligned undue stress is exerted on the parts thus causing failure. It could also lead to diminished or dysfunctional performance by the system even if the failure itself does not occur. Angular misalignment is again primarily a manufacturing time error and most of the time is corrected by manufacturing adjustments. However, in certain cases due to shortsighted design time decisions the part cannot be assembled without having a certain amount of angular misalignment. These decisions could involve wrong fastener selection, wrong part material selection leading to differential thermal expansion/contraction effects or even the shape of the parts.

ERROR CATALYSIS SHEET

DEFECT CLASS Misalignment	SPECIFIC DEFECT Angular misalignment	SHEET NO: B41
ERROR CATALYST Angular orientation coupled with cantilever effects causing misalignment.		
DESCRIPTION <p>In angular misalignment the angles involved in the mating planes with respect to the horizontal or vertical are of paramount importance. A check is performed to see whether the mating surfaces are at an angle; if they are, then in a large number of cases there will be angular misalignment due to the difficult machining and thermal effects. If no mating surfaces are at an angle, then it is necessary to find whether the mating surfaces are cantilevers. If they are not, then angular misalignment is unlikely to occur. If they are, however, then moving parts have a greater tendency to get angularly misaligned if they come into contact with solid or fluid bearings or if the C G of the parts is at an eccentric to the fulcrum.</p>		
CATALYSIS GRAPH		
<pre> graph TD Start[START ANALYSIS] --> Q1{Are There Mating Surfaces At An Angle To The Vertical Or The Horizontal?} Q1 -- Yes --> C1((1)) Q1 -- No --> Q2{Are There Cantilevers?} Q2 -- No --> C2((0)) Q2 -- Yes --> Q3{Is There A Moving Part?} Q3 -- Yes --> Q4{Does It Come Into Contact With A Solid Bearing Part?} Q4 -- No --> C3((0)) Q4 -- Yes --> Q5{Is The CG Of The Part To The Extreme End Of The Part?} Q3 -- No --> Q5 Q5 -- No --> C4((0)) Q5 -- Yes --> C5((1)) </pre>		

Figure 5.10 Angular orientation and cantilever effects

ERROR CATALYSIS SHEET

<i>DEFECT CLASS</i> Misalignment	<i>SPECIFIC DEFECT</i> Angular misalignment	<i>SHEET NO:</i> B42
<i>ERROR CATALYST</i> Fastener induced angular misalignment.		
<i>DESCRIPTION</i> This misalignment can occur directly or indirectly through the choice of fasteners if these conditions exist: <ul style="list-style-type: none"> -If the force is parallel, eccentric, or at an angle to the fastening axis (A1, A3, A4). -If the fastening accessibility is limited (C1 & C2). -If the fastening components are greater than or equal to 2 (F2 or F3). 		
<i>CATALYSIS GRAPH</i>		
<pre> graph TD Start[START ANALYSIS] --> Design[Fasteners In The Design] Design --> Table[Table] Table --> Decision{Do any of the fasteners fall into the category specified by the code A1 B(1-4) C(1-2) D1 E(1-3) F(2-3) A3 B(1-4) C(1-2) D1 E(1-3) F(2-3) A4 B(1-4) C(1-2) D1 E(1-3) F(2-3)} Decision -- Yes --> One((1)) Decision -- No --> Zero((0)) </pre>		

Figure 5.11 Fastener effects

The error catalysts in this case have been identified and catalogued along with their catalysis graphs in figures 5.10 and 5.11. The error catalysts identified for this particular specific defect are summarized below.

1. Angular orientation coupled with cantilever effects causing misalignment. B41
2. Fastener induced misalignment. B42

The pairwise comparison matrix is shown in figure 5.12.

	B41	B42	Row products
B41	1	2	2
B42	.5	1	.5

Figure 5.12 Relative weightage of error catalysts for angular misalignment

The normalized scores thus obtained for the three error catalysts are:

$$B41 = 1$$

$$B42 = 0.5$$

Using the equation 4.1, the QM score for the specific defect 'Angular Misalignment' can be given as:

$$Q_{4B} = \frac{S_{14B} + (.5 * S_{24B})}{3}$$

where S_{14B} and S_{24B} are the scores for the three error catalysts.

This defect is not frequently encountered as a direct consequence of design time decisions. However, the defect does occur and it could seriously jeopardize the performance of the product. The modification of the design to reduce the possibility of

occurrence of this defect is relatively difficult. This is because of the complicated interplay of factor variables which interact for it's occurrence.

5.2.4 Linear Misalignment

This is the most frequently encountered type of misalignment in assembled products and it does involve a lot of design time decision making to catalyze it's occurrence. The designs could have improper tolerance analysis or they could have been neglected from the point of view of thermal expansion or they may even have irregular stress distributions leading to linear displacement due to the release of residual stresses. These design oversights and other obscure factors like the assembly operation incompatibility or fastener effects have to be evaluated and their effects on the catalysis of this type of defect need to be evaluated and quantified if the methodology intends to preserve it's predictive capability. The error catalysts in this specific defect have been described along with their catalysis graphs in figures 5.13 through 5.15 and they can be summarized as:

1. Mating complexity causing misalignment. B31.
2. Misalignment due to thermal expansion/ contraction. B32.
3. Fastener induced misalignment. B33.

The pairwise comparison is shown in figure 5.16

	B31	B32	B33	Row products
B31	1	2	1.5	3
B32	.5	1	1.33	.665
B33	.66	.75	1	.496

Figure 5.16 Relative weightage of error catalysts for axial misalignment

ERROR CATALYSIS SHEET

DEFECT CLASS Misalignment	SPECIFIC DEFECT Linear Misalignment	SHEET NO: B31
ERROR CATALYST Mating complexity causing misalignment.		B31
DESCRIPTION		
<p>This error catalyst is evaluated from the basic characteristic of numbers of mating surfaces per number of mating parts. A large ratio, which is any >4, is automatically assigned a rating of '1'. because if a large number of mating areas are involved the tolerance stackup will invariably lead to linear misalignment in some direction. A ratio which is less than or equal to 1 requires additional evaluations of press fits and mating forces.</p> <p>For ratios ranging in value from 1 to 2, the number of fasteners positioned in a direction parallel to the axis of mating is evaluated. A value greater than 2 gaurantees the presence of a restraining force, and a rating of '0' is assigned. For designs with no fasteners in this direction , the direction of gravitational force will be the determinant in assigning the proper rating of 0 or 1.</p>		
CATALYSIS GRAPH		
<pre> graph TD A["No. of Mating Surfaces No. of Mating Parts"] -- "< 1" --> B["Is the Mating a Precise Fit?"] A -- "Between 1 and 2" --> C["No. of Fasteners Parallel to the Axis of Mating"] A -- "2" --> D((0.6)) A -- "3" --> E((0.8)) A -- "> 4" --> F((1)) B -- "Yes" --> G["Is the Force Available?"] B -- "No" --> H((0)) G -- "No" --> I((1)) C -- "> 0" --> J((0)) C -- "0" --> K["Direction of Gravitational Force"] K -- "In the Direction of Mating" --> L((0)) K -- "Opposite to the Direction of Mating" --> M((1)) </pre>		

Figure 5.14 Effects of mating complexity

ERROR CATALYSIS SHEET

DEFECT CLASS	SPECIFIC DEFECT	SHEET NO:
Misalignment	Linear Misalignment	B32
ERROR CATALYST		
Linear misalignment caused due to thermal expansion.		
DESCRIPTION		
<p>In the second error catalyst, the most significant factor is the coefficient of expansion of the materials. The ratio of the coefficients of expansion provides the primary criterion for evaluation in the second decision table. If <i>all</i> the ratios are around 1 ± 0.2, then they are directly given a rating of '0'. This is because the differential between the coefficients of expansion does not cause the axes to have relative movement or undergo axial misalignments. If <i>all</i> the ratios are outside this range, a rating of '1' is assigned, as the cumulative effects may cause the parts to move relative to one another at various locations, causing axial misalignments. If all the ratios are not outside this range, the point at which heating occurs is considered; if it is prior to assembly, axial misalignment can occur due to displaced axial locations--a rating of '1' is given. Otherwise, if the parts have fasteners or other positioning elements, a rating of '0' is assigned; if not, it is '1'.</p>		
CATALYSIS GRAPH		
<pre> graph TD Start([START ANALYSIS]) --> Ratios[Ratios of Coefficient of Expansion] Ratios -- "All in 1 ± 0.2" --> R0((0)) Ratios -- "Some Within 1 ± 0.2 And Some Without" --> Heating[Time of Heating] Heating -- "Prior to assembly" --> R1((1)) Heating -- "Post assembly" --> Clearance{Does the mating site or fastening location have clearance} Clearance -- "Yes" --> R1_2((1)) Clearance -- "No" --> R0_2((0)) Ratios -- "all outside 1 ± 0.2" --> Clearance Clearance -- "Yes" --> R0_3((0)) Clearance -- "No" --> R1_3((1)) </pre>		

Figure 5.15 Effects of differential thermal expansion

ERROR CATALYSIS SHEET

<i>DEFECT CLASS</i> Misalignment	<i>SPECIFIC DEFECT</i> Linear Misalignment	<i>SHEET NO:</i> B33
<i>ERROR CATALYST</i> Fastener induced misalignment.		
<i>DESCRIPTION</i>		
<p>The conditions of fastening which can cause linear misalignment include:</p> <p style="padding-left: 40px;">If the force is parallel to the fastening axis (A1) If the fastener is one with multiple component (F2 or F3) If the application of the fastener is manual (D1)</p> <p>The codes which have all of these factors present get a rating of '1'. The code sequence would be:</p> <p style="text-align: center;">A1, B(1to 4), C(1 to 5), D1, E(1 to 3), F(2 to 3)</p>		
<i>CATALYSIS GRAPH</i>		
<pre> graph TD Start[Start Analysis] --> Design[Fasteners in the design] Design --> Table[Table] Table --> Decision{Do any of the fasteners fall into the category specified by the code A1 B(1 to 4) C(1 to 5) D1 E(1 to 3) F(2 to 3)} Decision -- Yes --> Rating1((1)) Decision -- No --> Rating0((0)) </pre>		

Figure 5.16 Effects of fastener selection

The normalized scores thus obtained for the three error catalysts are:

$$B_{31} = 1 \qquad B_{32} = 0.221 \qquad B_{33} = 0.165$$

Using the equation 4.1, the QM score for the specific defect 'Linear Misalignment' can be given as:

$$Q_{B3} = \frac{S_{B31} + (.221 * S_{B32}) + (0.425 * S_{B33})}{3}$$

where S_{B31} , S_{B32} and S_{B33} are the scores for the three error catalysts.

This defect can be noticed in almost all assembled products and is the first sign of wear and tear after an extended period of use. That case of loose covers, doors or other assembled parts is a natural consequence of use and cannot be controlled by manufacturing. However, in the finished products, if the fitting of two parts is not perfect and linear dislocation is evident, then either the manufacturing process needs to be analyzed and a more comprehensive quality control program initiated or in case that does not work the design needs to be reconsidered. This can be done while designing the product initially by using the DFQM methodology.

5.2 QM Results Based on the Analysis

Using the same methodology as described in section 4.5 we get a cumulative score for the defect class 'Misalignments'. The comparative analysis of the four specific defects is shown figure 5.17.

Sp. defect s	B1	B2	B3	B4	Row products
B1	1	2	1	4	8
B2	.5	1	.5	2	.5
B3	1	2	1	4	8
B4	.25	.5	.25	1	.0625

Figure 4.13 Relative weightage of specific defects in the defect class 'Misalignments.'

Thus the normalized scores for the three specific defects are given as

$$B1 = 1 \qquad B2 = .0625 \qquad B3 = 1 \qquad B4 = .007$$

Using the equation 4.2, the score for the defect class is given as,

$$C_B = \frac{Q_{1B} + (0.0625 * Q_{2B}) + Q_{4B} + (.007 * Q_{3B})}{3}$$

This score also is analyzed with respect to other defect classes for all the parts in the QMM. This analysis provides us with the information about the possible weaknesses in the design from the perspective of QM.

CHAPTER 6

CONCLUSIONS AND FUTURE RESEARCH

6.1 Conclusions

The methodology attempts to create a definite relationship between the design, manufacturing and the quality of the product. This is presented in the form of a distinct pattern of functional dependencies between the influencing factors (through influencing factors, error catalysts and specific defects) and defect classes. In this thesis, work conducted by Tamboo (1994) and Ramachandra (1994) is extended to cover the remaining specific defects identified in the DFQM scheme (Appendix A). The defect classes, misalignments and fastener related problems are analyzed in detail and the error catalysts under all of the specific defects in these categories are catalogued.

The positional relationships and functional relationships between various mating parts play an important role in the catalysis and transmission of defects in the assemblies while they are being put together. These are identified and then classified in this work. Fasteners are also classified from the perspective of this scheme.

With the conclusion of this work a general schema for the relationships has been created and the related calculations have been identified such that any design can be fundamentally analyzed for its DFQM characteristics in fastener related problems and misalignments and the weaknesses can be extracted. This procedure would require a set

group of classifications and charts to analyze designs, these have been created and presented.

Hence, the first cut at a fundamentally functional DFQM methodology has been created. This methodology has to be debugged and polished however the schema has been established.

6.2 The Computer (PC) Based Front End

In order that the use of the methodology is facilitated and the information base be readily accessible the project has diversified into creating a PC based application which can be easily used by designers to analyze their designs. the preliminary steps in this direction have already been taken with the initiation of the database based program.

The software platform of choice in this case has been the popular Microsoft database application called 'Access'. This is a relational database which has an inbuilt front end so that a customized application can be generated. Presently the computer being used is an IBM compatible 486dx with extended RAM. The easy accessibility of such machines and the MS-Access software guarantees the portability of the application such that designers at remote locations can concurrently evaluate designs.

The schema of the database architecture has been presented in figure 6.1. In this diagram the basic structure is presented. The database consists of a *static DFQM database* which contains the relationships, error catalysts, classification charts and related calculations. The user is not expected to have any access to this database. The static

database is operated upon along with the *dynamic input database* by a set of *queries* which are basically the procedural instructions of the methodology. The user accesses the

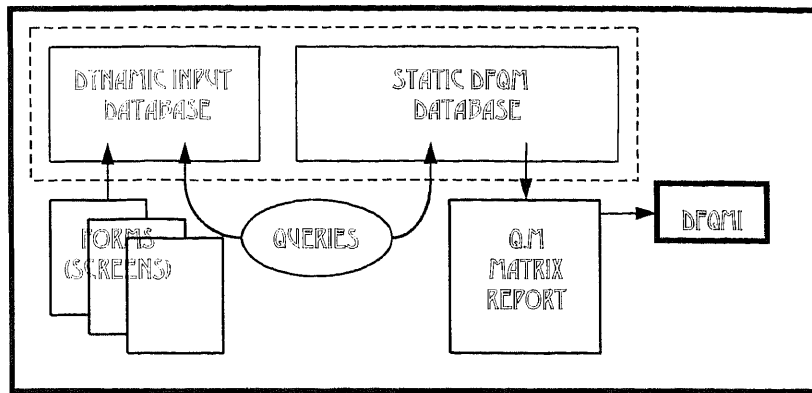

Figure 6.1 Conceptual architecture of the DFQM database application.

dynamic input database via a set of onscreen forms which are customized for use in this application and are concise and easy to understand . The information about each design inputted into the application is stored in independent files which can be transported for use in the application at another location.

The output of the process is in the form of a matrix called the quality manufacturability matrix (QMM). The results in this matrix present the detailed results of the DFQM analysis and they are translated into a DFQM index which can be utilized among other things for benchmarking. Appendix D & E illustrate the preliminary design of the screens used for data input.

Presently the input database is being thought of as consisting three main entities, parts, matings and fasteners. These are related to each other via common attributes. The design uniqueness is established in another table. The attributes of the three entities cover

the range of influencing factors in the scheme. The structure of the static database is being conceived as very similar to the schema illustrated in appendix A. The queries are written via the access platform but can be translated into SQL in case 'C' embedding is required.

6.3 Future Work

The scope of this thesis is limited to two defect classes out of six classes identified in the DFQM structure. Immediate future research is required to verify and validate all the analysis conducted on four of the six classes (Two classes were analyzed by Tamboo, A. Y.). The remaining two classes have to be analyzed and the results documented and catalogued according to the set format.

The calculation of error catalysis and transmission needs to be mathematically verified and experiments need to be conducted to validate the theoretical model constructed. However, in the immediate future a simultaneous effort has to be made to completely set up the methodology in the PC application form.

Extended research plans also could include integration of CAD packages like ProEngineer into the methodology such that the user could analyze any assembly by clicking on an icon. This could be done by extracting all the pertinent information from the CAD based model itself.

SCHEMATIC FOR ESTIMATING THE QUALITY MANUFACTURABILITY OF A DESIGN

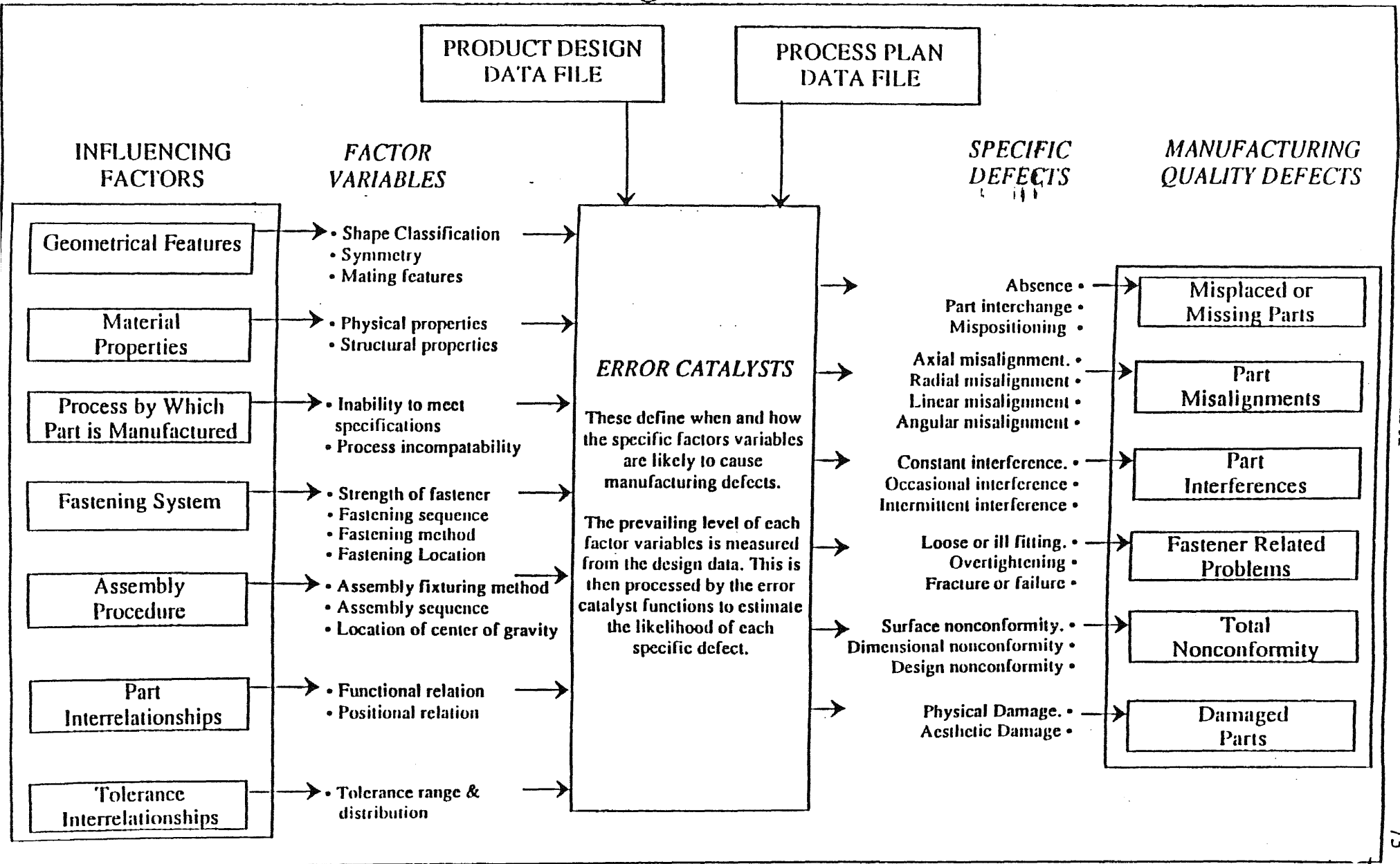

	SYMMETRICAL PARTS (all three axes)					
	UNIFORM CROSS-SECTION 1	NON - UNIFORM CROSS-SECTION 2	STEP, CORNER, PROTRUSION			
			AT ENDS		IN CENTRAL POSITION	
			REGULAR 3	COMPLEX CONTOUR 4	REGULAR 5	COMPLEX CONTOUR 6
ROUND R						
BAR OR RECTANGLE B						
SECTION S						
TUBULAR T						
FLAT F						
SPHERICAL P			NA	NA		

© 1994
Department of Mechanical
& Industrial Engineering

Developed under a grant from the
National Science Foundation



DFQM CLASSIFICATION OF PARTS BY SYMMETRY & GEOMETRY

APPENDIX B

PART SYMMETRICAL TO ONE AXIS														NON - SYMMETRICAL PARTS		
MAIN FEATURE CAUSING ASYMMETRY														MAIN FEATURE CAUSING ASYMMETRY		
TRANSVERSE ELEMENTS				GROOVES, HOLES										SPATIAL CURVATURE	STEPS, HOLES, GROOVES, & TRANSVERSE ELEMENTS	COMPLEX ELEMENTS
PERPENDICULAR TO AXIS OF SYMMETRY		PARALLEL TO AXIS OF SYMMETRY		CONCENTRIC GROOVES		CUT PARALLEL TO AXIS OF SYMMETRY				CUT PERPENDICULAR TO AXIS OF SYMMETRY						
0.25A ≤ L ≤ 0.5A 7	0.5A < L ≤ A 8	0.25A ≤ L ≤ 0.5A 9	0.5A < L ≤ A 10	SINGLE 11	MULTIPLE 12	NUMBER OF CUTS ≤ 2		NUMBER OF CUTS > 2		NUMBER OF CUTS ≤ 2		NUMBER OF CUTS > 2				
						BLIND 13	THROUGH 14	BLIND 15	THROUGH 16	BLIND 17	THROUGH 18	BLIND 19	THROUGH 20			
21	22	23														
				NA	NA											
				NA	NA											
				NA	NA											
														NA		NA

Parts symmetrical to only one axis of symmetry may contain more than one feature i.e. step, groove, transverse elements. In such cases, the following rules will be applied to uniquely identify the part:

- The part will be identified with respect to the main feature that causes asymmetry; i.e., if this feature is to be removed, the part will become symmetrical.
- If rule 1., stated above, does not give a unique identification, the part shall belong to the respective column classifications based on the following order of preference:
 - Grooves/Hole
 - Transverse Elements
 - Steps

NOTES :

- A Length of the rectangular envelope that would enclose the entire part.
- L Length of the rectangular envelope enclosing the transverse element.
- ⊙ Implies the axis of symmetry is perpendicular to the plane of the paper.
- X Indicates the axis of symmetry wherever it is difficult to identify.
- Blind hole/groove
- Flat - Shape with a very low thickness as compared to its length and width
- Step - Geometric feature that results in a deviation of the silhouette of a part from the silhouette of its envelope.
- Transverse Element - External projection other than beta symmetric step that can be seen in a silhouette with length of projection greater than 1/4 of A.

Groove - A cut that results in a deviation of a part from the silhouette of its envelope.

Blind Groove/Hole - Groove/hole which does not cut through the part lengthwise (length of the groove/hole).

Through Groove/Hole - Groove/hole which cuts through the part lengthwise (length of the groove/hole).

Direction of Groove Cutting - Means the direction in which the length of the groove runs (not the depth of the cut).

Silhouette - The smallest simple geometric outline that encloses the view of a part or its envelope.

Spatial Curvature - A non-symmetrical curved shape.

NA - Not Applicable

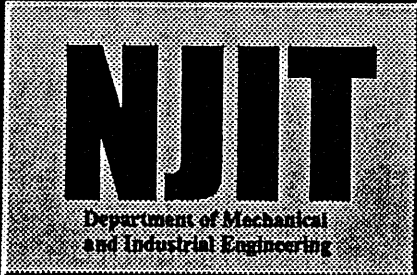

- Enter a new design
- Enter the factor variables
- Preliminary specific
- Go to the database
- Exit to windows

The Design For Quality Manufacturability Index.

DFQM

APPENDIX D

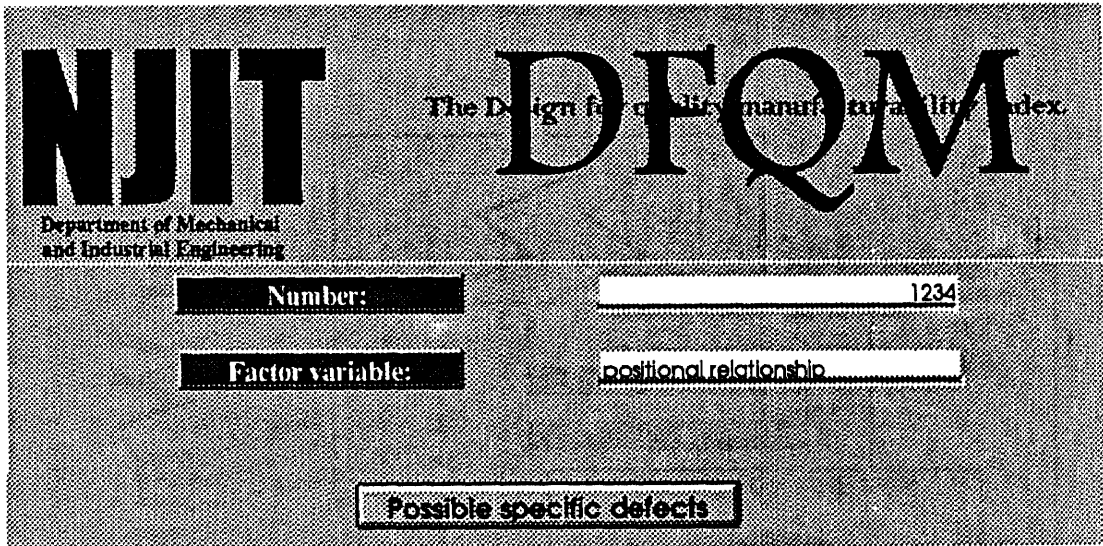

NJIT
Department of Mechanical and Industrial Engineering

The Design for Quality Manufacturing Index

DFQM

Number:

Factor variable:

Possible specific defects

REFERENCES

- Anonymous. "What design can do for manufacturing". *Machine Design*. January 24, 1994.
- G. Ben-Arieh. "A methodology for analysis of assembly operations' difficulty". *International Journal of Production Research*, Vol. 32, No.8, 1994.
- G. Bengu, B. Prasad, A. Dhar "Multi-Agent Based Cooperative Framework to Support Concurrent Engineering." *Proceedings. CERA, First International Conference on Concurrent Engineering*. Pittsburgh PA. August 1994.
- Paul R. Boneneberger "Stretching the limits of DFM." *Machine Design*. Vol 66, Iss 17. pp 67-70. September 12 1994.
- G. Boothroyd and P. Dewhurst. *Product Design for Assembly Handbook*. Wakefield, RI: Boothroyd-Dewhurst Inc., 1987.
- X. Chu and H. Holms. "Product Manufacturability Control for Concurrent Engineering." *Computers in Industry (CII)*. Vol: 24, Iss: 1. pp: 29-38. May 1994.
- John J. Cocco, Dennis Callahan and Tom Bassinger. " DFMA Quantifies Value of Adhesive Assembly Options." *Adhesives Age*. Vol 35, Iss 7. pp 28-31. June 1992
- D. Daetz "The Effect of Product Design on Product Quality and Product Cost." *Quality Progress*. pp 63-67. June 1987
- S.K Das "Design for Quality Manufacturability: An Approach for Improving The Quality of Assembled Products." Under review by the *IIE Transactions*. June 1993.
- W. Deming. *Out of Crisis*. Cambridge, MA: MIT Center for Advanced Engineering Study, 1986.
- DoN Report. *Producibility Measurement Guidelines: Methodology for Product Integrity*. Washington, DC: Final Draft NAVSO P-xxxx, December 1991.
- P.W Fox, Jr. and Jerry Grunor. "Keeping Sheet Metal Together". *Machine Design*, December 10, 1993.
- Paul R. Franco. "Are your fasteners safe?". *Machine Design*, December 10, 1992.
- E. L. Grant and R.S Leavenworth. "*Statistical Quality Control*". 6 ed. NY. Mc Graw Hill Book Company, Inc. 1988.

- Tony Grezsik. "Top Down Design." *Printed Circuit Design*. June 1992.
- S.M Johnson. "Auto adhesives a sticky subject". *Machine Design*. December 10, 1993.
- Michael Marsh. "Like Needles in a Haystack: Extracting DFM from CAD Data." *Printed Circuit Design*. Vol: 9, Iss: 6. pp 24-27. June 1992.
- B.S Moskal. "Product Design: GM's New Found Religeon." *Industry Week*. Vol: 241 Iss: 10. pp: 46-53. May 18, 1992.
- M. Phadke "*Quality Engineering Using Robust Design*." Englewood Cliffs, NJ: Prentice Hall, 1989.
- J. Potechin "Integrating DFM." *Printed Circuit Design*. Vol: 10, Iss: 11. pp: 22-26. Nov 1993.
- S. Prasad. "Design for Quality Manufacturability: Formulation of Macro Architecture for DFQM Methodology." Masters Thesis. New Jersey Institute of Technology. June 1992.
- S. Ramchandra. "Design for Quality Manufacturability of Common Assembly Processes." Masters Thesis. New Jersey Institute of Technology. December 1994.
- Ramana Reddy, Ralph T. Wood and Joseph K. Cleetus. "The Darpa Initiative: Encouraging New Industrial Practices." *IEEE Spectrum*. pp 26 -28. July 1991.
- Harold A. Rothbart. *Mechanical design and systems handbook*. 2nd ed. Mc. Graw Hill Book Company.
- Thomas L. Saaty. "A scaling method for priorities in Hierarchial structures". *Journal of Mathematical Psychology* 15, 234-281 1977.
- J. Schey. *Introduction to Manufacturing Processes*. 2nd.ed. NY: McGraw-Hill Book Company, Inc., 1987.
- W. A. Shewhart. *Economic Control of Quality of Manufactured Product*. D. Van Nostrand Company, Inc., Princeton, N.J 1931.
- J. Shigley. *Mechanical Engineering Design*. 1st. ed. NY: McGraw-Hill Book Company, Inc., 1963.
- Sammy G. Shina. "New Rules for World Class Companies." *IEEE Spectrum*. pp 23-24 July 1991.

Bryan Siegal. "Organizing for a Successful CE Process." *Industrial Engineering*. December 1991.

H. Stoll. "Design for Manufacture." *Manufacturing Review*. pp 23-29. January 1988.

N. Suh, A. Bell, and D. Gossard. "On an Axiomatic Approach to Manufacturing and Manufacturing Systems." *ASME Journal of Engineering for Industry*. 100.2, pp 127-130. 1978.

L. Sullivan. "The Power of Taguchi Methods." *Quality Progress*. pp 76-79. June 1987.

Altaf Y. Tamboo. "Design for Quality Manufacturability Analysis of Missing/Misplaced Parts and Part Interference." Masters Thesis. New Jersey Institute of Technology. December 1994.

K. Ulrich, D. Sartorius, S. Pearson and M. Jakiela. "Value of Time in Design-for-Manufacturing Decision Making." *Management Science*. 39.4. pp 429-447. 1993

M. Wozny. "A Unified Representation to Support Evaluation of Designs for Manufacturability: Phase 2." Rensselaer Design Research Center, RPI, Troy, NY.