

## **Copyright Warning & Restrictions**

The copyright law of the United States (Title 17, United States Code) governs the making of photocopies or other reproductions of copyrighted material.

Under certain conditions specified in the law, libraries and archives are authorized to furnish a photocopy or other reproduction. One of these specified conditions is that the photocopy or reproduction is not to be “used for any purpose other than private study, scholarship, or research.” If a user makes a request for, or later uses, a photocopy or reproduction for purposes in excess of “fair use” that user may be liable for copyright infringement,

This institution reserves the right to refuse to accept a copying order if, in its judgment, fulfillment of the order would involve violation of copyright law.

**Please Note: The author retains the copyright while the New Jersey Institute of Technology reserves the right to distribute this thesis or dissertation**

Printing note: If you do not wish to print this page, then select “Pages from: first page # to: last page #” on the print dialog screen

The Van Houten library has removed some of the personal information and all signatures from the approval page and biographical sketches of theses and dissertations in order to protect the identity of NJIT graduates and faculty.

## ABSTRACT

### **Laser Treatment of Ceramic Coatings on Defective Ceramic Glazed Tile**

by  
**Gousinn Yu**

Laser surface melting treatment was achieved by a 2 Kw CO2 surgical laser system. The partially defocused laser beam provided a circular spot with an annular energy distribution on the sample.

It is certain that laser surface treatment will do the job of repairing in defective ceramic tiles. All glazes provided by American Standard were tested for an ability of withstand laser treatment when coated on to a glazed tile. In order to repair the defective ceramic tile it is necessary to patch the damaged region with a cement. The cement must then be glazed in order to match that of the undamaged portion of the ceramic tile. I worked on the exact process parameters under which this glazing should take place. I also zeroed on the exact requirement of materials for a perfect color match with the base material. The experiments have been conducted keeping in mind the ease of industrial implementation.

Robert W. Woodruff Library  
New Jersey Institute of Technology  
Newark, New Jersey 07102 ✓

**LASER TREATMENT OF CERAMIC COATINGS  
ON DEFECTIVE CERAMIC GLAZED TILE**

by  
**Gousinn Yu**

*Robert W. Van Houten Library  
New Jersey Institute of Technology  
Newark, New Jersey 07102*

**A Thesis  
Submitted to the Faculty of  
New Jersey Institute of Technology  
in Partial Fulfillment of the Requirements for the Degree of  
Master of Science in Engineering Science**

**Committee for the Interdisciplinary Program in  
Materials Science and Engineering**

**January 1994**

**APPROVAL PAGE**

**LASER TREATMENT OF CERAMIC COATINGS  
ON DEFECTIVE CERAMIC GLAZED TILE**

**Gousinn Yu**

---

Dr. Roland Levy, Thesis advisor Date  
Professor of Materials Science and Engineering, NJIT

Dr. James M. Grow, Thesis co-advisor Date  
Professor of Materials Science and Engineering, NJIT

Dr. David, Kristol Date  
Professor of Materials Science and Engineering, NJIT

## **BIOGRAPHICAL SKETCH**

**Author:** Gousinn Yu

**Degree:** Master of Science in Engineering Science

**Date:** January 1994

### **Undergraduate and Graduate Education:**

- Master of Science in Engineering Science,  
New Jersey Institute of Technology, Newark, NJ, 1994
- Master of Science in Mechanical Engineering,  
New Jersey Institute of Technology, Newark, NJ, 1992
- Bachelor of Science in Materials Engineering,  
Nanchang Aeronautical Institute of Technology,  
Nanchang, People's Republic of China, 1987

**Major:** Materials Engineering

### **Presentations and Publications:**

Yu, Gousinn and Xianchai Chau "A Study on the Contamination Free Vacuum in TEM" 1987 B.S Thesis Nanchang Aeronautical Institute of Technology, People's Republic of China.

This thesis is dedicated to my parents

## ACKNOWLEDGMENT

This work is part of tile project on laser treatment of ceramic coating on defective ceramic glazed tile supported by American Standard.

I would like to take this opportunity to express my deepest gratitude to Dr. D. E. Murnick, Professor and Chairperson of Physics Department of Rutgers University-Newark Campus, for his valuable guidance throughout the course of this work. It was a honour to work under the guidance of my esteemed teacher.



## TABLE OF CONTENTS

<b>Chapter</b>	<b>Page</b>
1 LASER HEATING TREATMENTS .....	1
1.1 Introduction to CO2 Laser .....	1
1.2 CO2 Pulsed and Continuous Wave Laser .....	2
1.3 Laser Treatment Technology .....	4
2 INTRODUCTION TO THE STUDY .....	5
3 MATHEMATICAL MODELING OF GAUSSIAN LASER TREATMENT .....	6
3.1 Mathematical Modeling of Temperature .....	6
3.2 Mathematical Modeling of Stresses, and Strains .....	9
4 EXPERIMENTAL PROCEDURES .....	13
5 RESULTS AND DISCUSSIONS .....	18
5.1 Experiments with Saureusen Cement and Frit and Tin Oxide and Saureusen Liquid .....	19
5.2 Experiments with Color Match of the Base Material .....	19
5.3 Experiments on the Change of Flux of the Laser Beam with Time .....	20
6 CONCLUSIONS .....	21
APPENDIX .....	22
REFERENCES .....	28

## LIST OF FIGURES

Figure	Page
1 CO2 pulsed laser wave . . . . .	2
2 CO2 continuous laser wave . . . . .	3
3 Three dimensional representation of temperature in power and depth for the laser radiation . . . . .	7
4 Three dimensional representation of temperature in time and beam diameter for the laser radiation . . . . .	8
5 Three dimensional representation of stress of stress in depth and radius for the laser radiation . . . . .	11
6 Three dimensional representation of stress in power and radius for the laser radiation . . . . .	12

## CHAPTER 1

### LASER HEATING TREATMENTS

#### 1.1 Introduction to CO<sub>2</sub> Laser

It is now over 10 years since the CO<sub>2</sub> gas laser was developed. During that time the CO<sub>2</sub> gas laser has become well established as a tool in the laboratory, in the shop, and in the production line. A CO<sub>2</sub> laser is based on the principle of transfer of vibrational energy from N<sub>2</sub> to CO<sub>2</sub>. In this system N<sub>2</sub> is excited in a rf discharge to produce vibrationally excited N<sub>2</sub>( X<sup>1</sup>Sg + v''=1) molecules, Which stream into an interaction region to mix with unexcited CO<sub>2</sub>. The CO<sub>2</sub> is then vibrationally excited through the reaction  $N_2 ( X^1Sg + v'' =1) + CO_2 (00^0_0) \rightarrow N_2 ( v''=0) + CO_2 (00^0_1) - 18 \text{ cm}^{-1}$ .

Laser emission subsequently occurs from rotational levels of the (00<sup>0</sup><sub>1</sub>) state to rotational levels of lower vibrational states. In direct laser writing, focused beams are used to modify surfaces by chemical processes that lead to deposition. This is often accomplished by locally heating the substrate using a focused laser with a Gaussian profile in the presence of a suitable reactant. During the course of this surface modification, large thermoelastic stresses and strains may be induced, which can produce defects and leave behind built-in stresses in and near the modified area. These effects can lead to serious consequences in performance, especially in microelectronics, where many important applications of laser writing have been investigated. Similar problems may also arise in annealing and recrystallization using focused lasers and electron beams.

## 1.2 CO<sub>2</sub> Pulsed and Continuous Wave Laser

In pulse wave of operation, the laser output is a single pulse for a determined length of time for each activation of the footswitch.

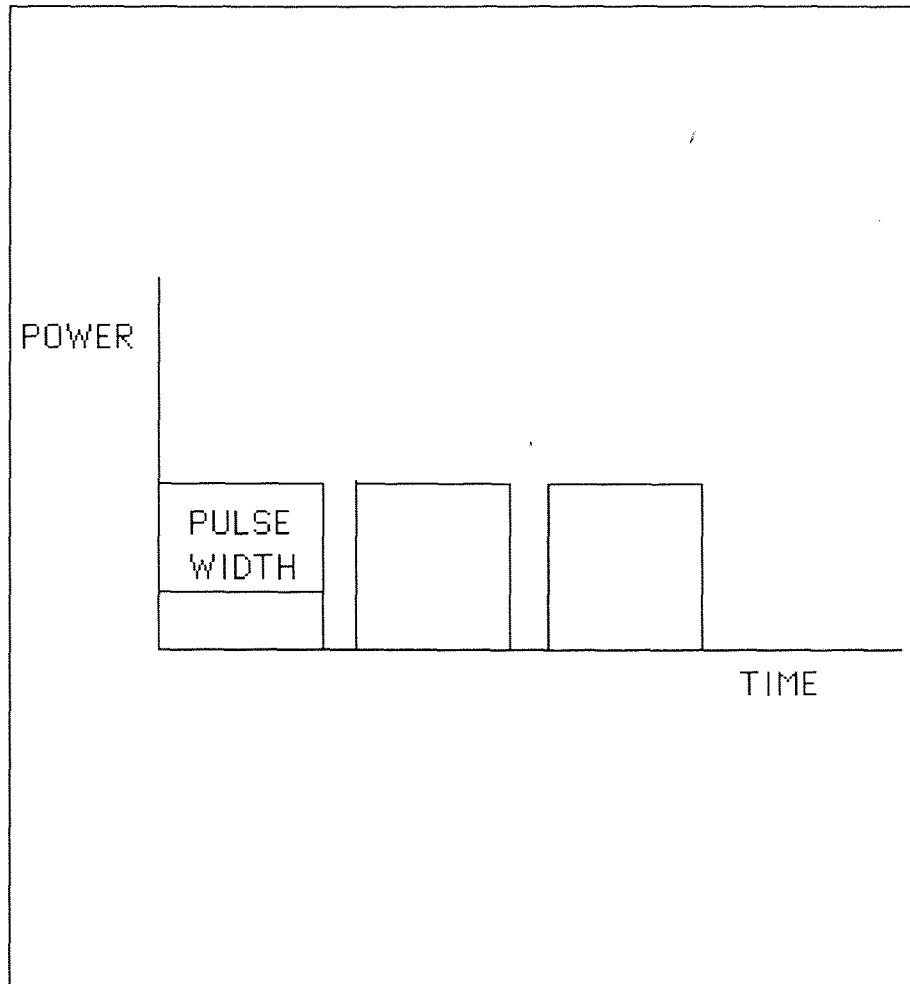

**Figure 1** CO<sub>2</sub> pulsed laser wave

In continuous wave of operation, the laser output is continuous from the time. The footswitch is activated until it is deactivated.

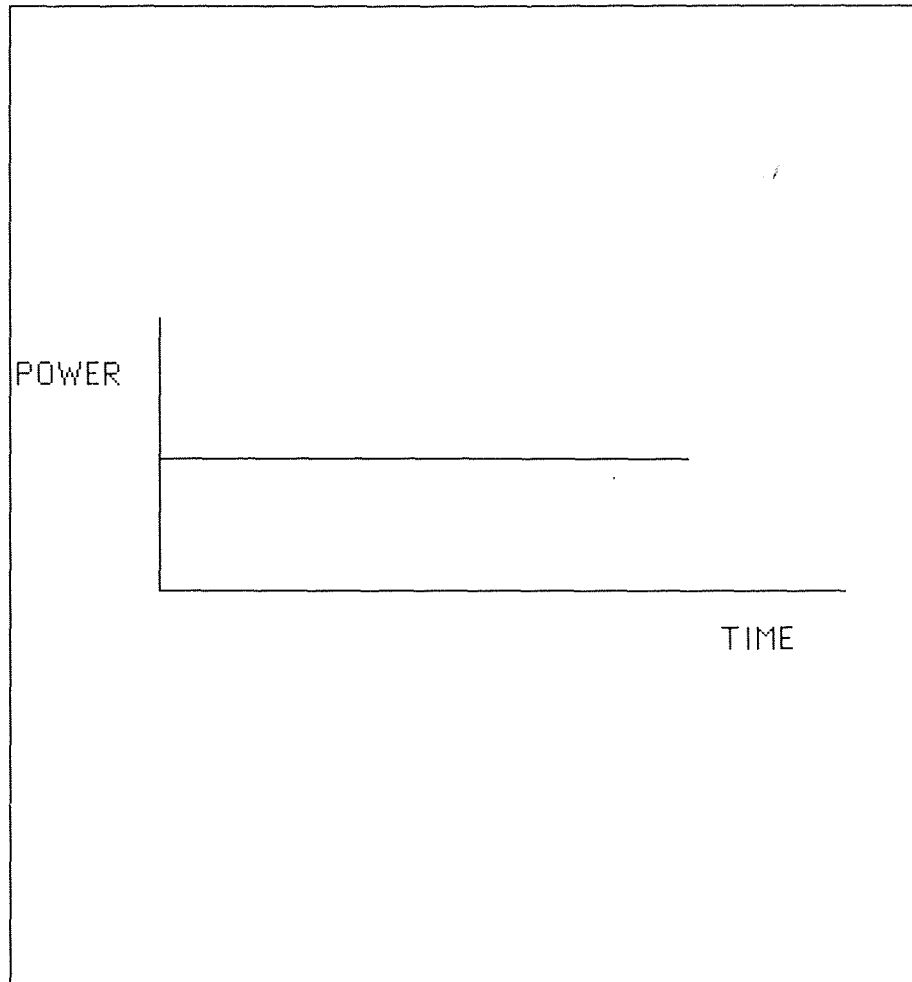

**Figure 2** CO2 continuous laser wave

### 1.3 Laser Treatment Technology

The use of lasers by the manufacturing industry is rapidly increasing in such applications as cutting of metals and nonmetals, heat treating, welding and cladding. Fundamental to all laser materials processes is the absorption of the incident radiation and the subsequent dissipation of the absorbed energy through the material. Since the temperature and its rate of change are a direct result of the heat dissipation process, a record of the temperature transients in the materials being processed can provide information on the quality of the process. One of the important areas of applications of lasers is the melting. In conventional melting, the energy absorption is at the surface and conduction plays the key role in transferring energy. The important variables in the laser melting process are the laser beam power, beam velocity, beam diameter, and the thermal properties of the materials including the surface characteristics such as absorptance. An optimal zone of treatment could be defined at medium powers and short interaction times with fine and homogeneous microstructure. However, the shrinkage due to the reduction in porosity involved a lot of random microcracks which lowered the mechanical properties. On the other hand, some cracks were suitable to accommodate thermal stresses. The problem is then to control the microcracking induced by the laser melting and rapid cooling process.

## CHAPTER 2

### INTRODUCTION TO THE STUDY

The basic premise of the project, has been that in order to successfully glaze a ceramic materials the delivered radiation must follow a defined protocol, developed by Professor D. E. Murnick. The protocol was to be achieved in a three fold manner, acquisition of a CO<sub>2</sub> surgical laser system, a suitable power delivery system and an automated control system interfaced to the power delivery unit. To date, all necessary equipment pertinent to the project has been obtained. In addition, a laser profile monitor was obtained to accurately measure the spatial power density of the delivered laser radiation.

Various pastes applied to the defective tiles were radiated by Gaussian Laser beam. The pastes were made from various cement materials in different ratios. A pulsed or continuous CO<sub>2</sub> laser was used for this purpose. The temperatures and the stresses or strains of the cements created by the laser beam are determined by using the heat flow equation and the stress(strain) equations.

The whole region and edge region of the cement change phases during laser processing. The adhesion between the cement and the tile is very good. The conditions and the mechanism of laser treatment are discussed.

## CHAPTER 3

### MATHEMATICAL MODELING OF GUASSIAN LASER TREATMENT

It is obvious that cement material must have high melting temperature to avoid getting overheated cement surface during radiation. Prof.D.E.Murnick suggested the use of theoretical techniques to control the temperature and stresses(or strains). He suggested the use of the heat flow equation showing temperature correlated with the changing in power density (power and diameter), depth and time of radiation and the use of the stress(or strain) equations showing stresses (or strains) correlated with the changing in depth, power density(power and diameter) and radiation time.

#### 3.1 Mathematical Modeling of Temperature

Use the heat flow equation to determine the temperatures:

$$T(z,t)=(2 q_0 / k) \text{Sqrt}(a t) \text{ierfc}[z/(2 \text{Sqrt}(a t))]$$

$q_0$ : absorbed power density

$k$ : conductivity

$a$ : thermal diffusivity

$t$ : radiation time

$z$ : radiation depth



A) Temperature is function of laser power and radiation depth(3-Dimensions)

time = 2 sec (constant)

diameter = 0.41142 cm (constant)

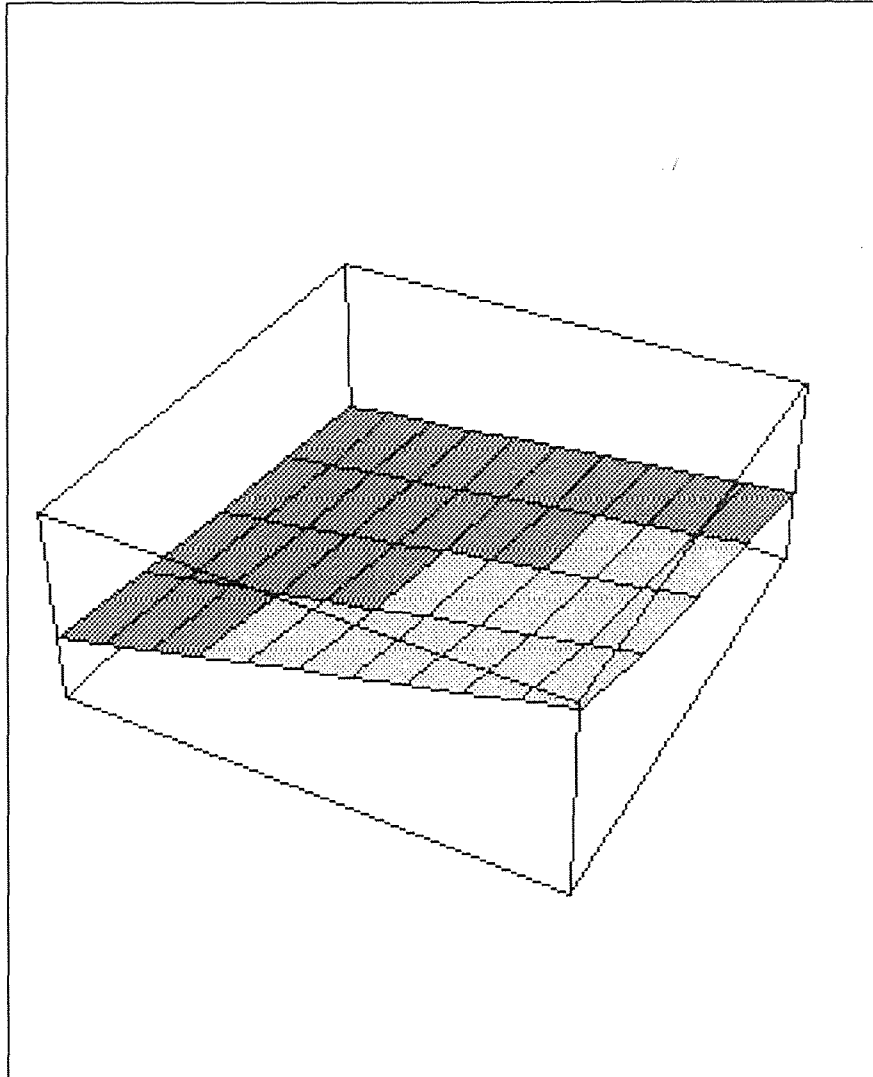
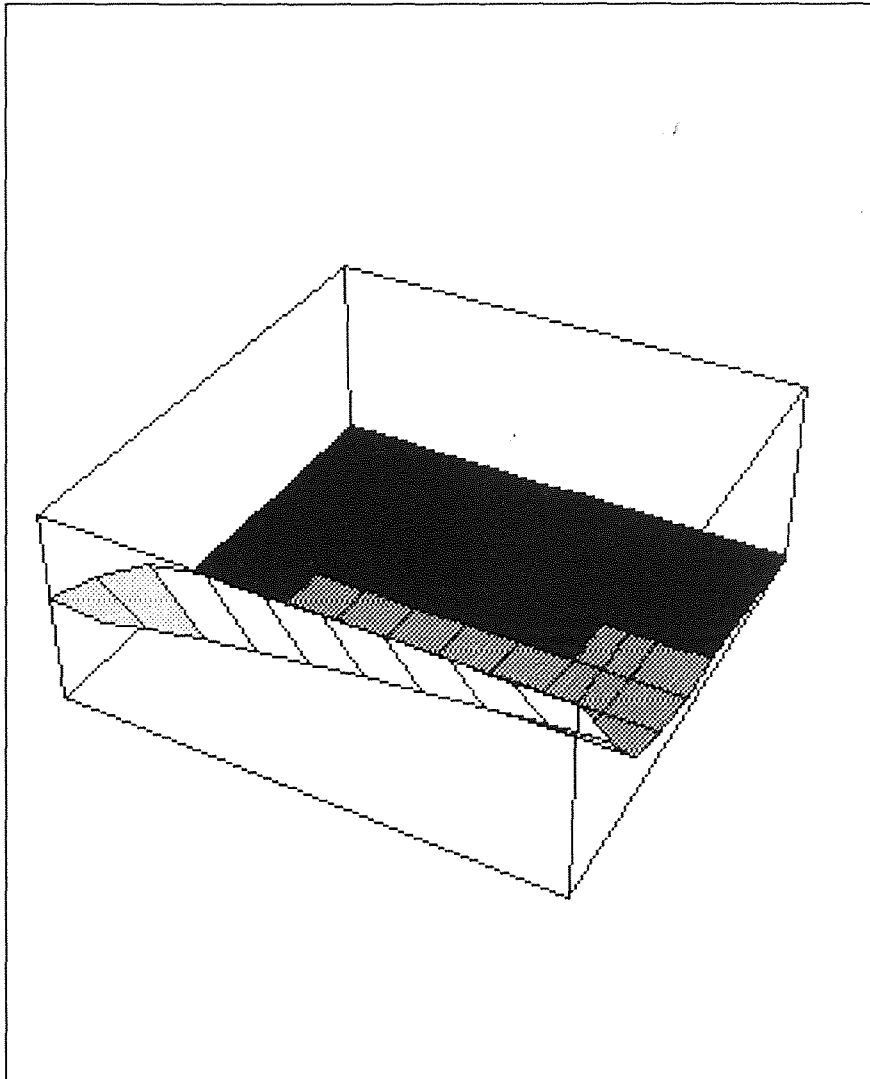

**Figure 3** Three dimensional representation of temperature in power and depth for the laser radiation described. Power increases to the lower right, depth to the upper right and temperature vertically.

B) Temperature is function of radiation time  
and beam diameter(3-Dimensions)

depth = 0 cm ( surface)

power = 10 watts (constant)



**Figure 4** Three dimensional representation of temperature in time and beam diameter for laser radiation. Time increases to the upper right, diameter to the lower right and temperature vertically.

### 3.2 Mathematical Modeling of Stresses and Strains

Stress is associated with the presence of the cracks itself, and the stress in most bodies will not be uniform. If a crack is initiated in a region of high stress and then propagates toward a region of lower stress, there is always a possibility that it will stop propagating in the lower-stress region.

Thermal shock is another means of introducing large stresses and steep gradients within a material. The basic concepts of the fracture mechanics outlined before will still be valid, of course, but the distribution of the heat input in time and space and the thermal properties of the material must be considered.

Internal stresses gradients can also be introduced during the fabrication of parts. Polyphase material having phases of differing thermal expansion can have large internal stresses if the phases are sintered at a high temperature and then cooled to a lower temperature. A similar effect can occur in a single-phase material if the thermal expansion coefficient of the individual grain is very anisotropic.

A material undergoing a phase change after sintering also can develop high internal stress. All of these various internal stress distributions can contribute significantly to the strain energy of a piece and make it much more susceptible to rapid crack propagation.

Use the thermal stress and strain formulas to determine the stresses and strains:

For  $r \gg w$

$$s_{rr} = (2 \sigma_m w [\sqrt{r^2 + z^2} - z]) / (r^2 \sqrt{P})$$

$$s_{\theta\theta} = (2 \sigma_m w z [\sqrt{r^2 + z^2} - z]) / (r^2 \sqrt{P} \sqrt{r^2 + z^2})$$

$$s_{zz} = (-6 \sigma_m w z^2 / ((1 - W) a^2 \sqrt{P})) * (3 / (r^2 + z^2)^{5/2} - 5 z^2 / (r^2 + z^2)^{7/2})$$

$$s_{rz} = (6 \sigma_m w z / ((1 - W) a^2 r \sqrt{P})) * (2 / (r^2 + z^2)^{3/2} - 7 z^2 / (r^2 + z^2)^{5/2} + 5 z^4 / (r^2 + z^2)^{7/2})$$

$$e_{rr} = (z \epsilon_m w [\sqrt{r^2 + z^2} - z]) / (r^2 \sqrt{P} \sqrt{r^2 + z^2})$$

$$e_{\theta\theta} = (w \epsilon_m [\sqrt{r^2 + z^2} - z]) / (r^2 \sqrt{P})$$

$$e_{zz} = (w \epsilon_m) / (\sqrt{P} \sqrt{r^2 + z^2})$$

$$e_{rz} = (-6 w z \epsilon_m / ((1 - W) a^2 r \sqrt{P})) * (2 / (r^2 + z^2)^{3/2} - 7 z^2 / (r^2 + z^2)^{5/2} + 5 z^4 / (r^2 + z^2)^{7/2})$$

$$\sigma_m = -E a T_m / 2$$

$$\epsilon_m = (1 + W) a T_m$$

$$T_m = [P (1 - R_o)] / [2 K w \sqrt{P}]$$

P: laser power

R<sub>o</sub>: surface reflectivity

a: absorption coefficient

w: beam waist

z: radiation depth

E: Young's modulus

a: coefficient of thermal expansion

k: thermal conductivity

r: x-direction distance

W: poisson's ratio

A) Stress is function of radiation depth and radius (3-Dimensions)

Stress-z-r

power=12 watts (constant)

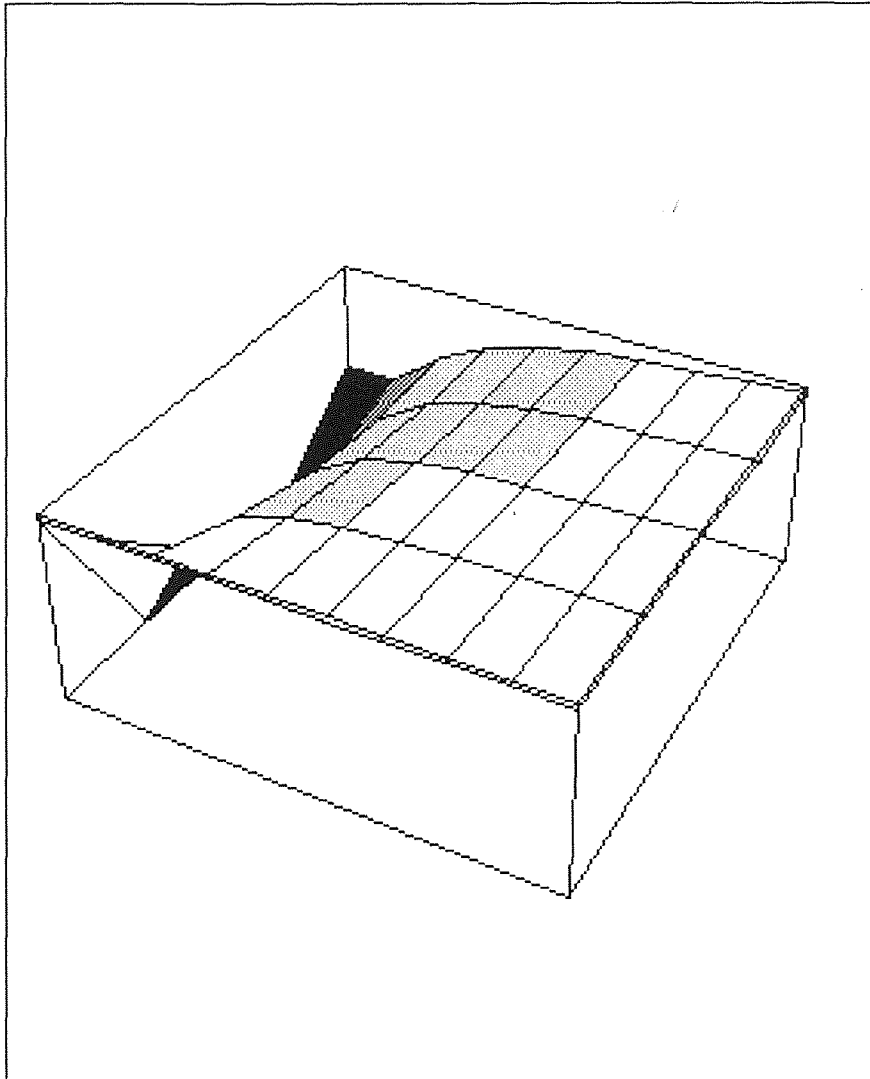
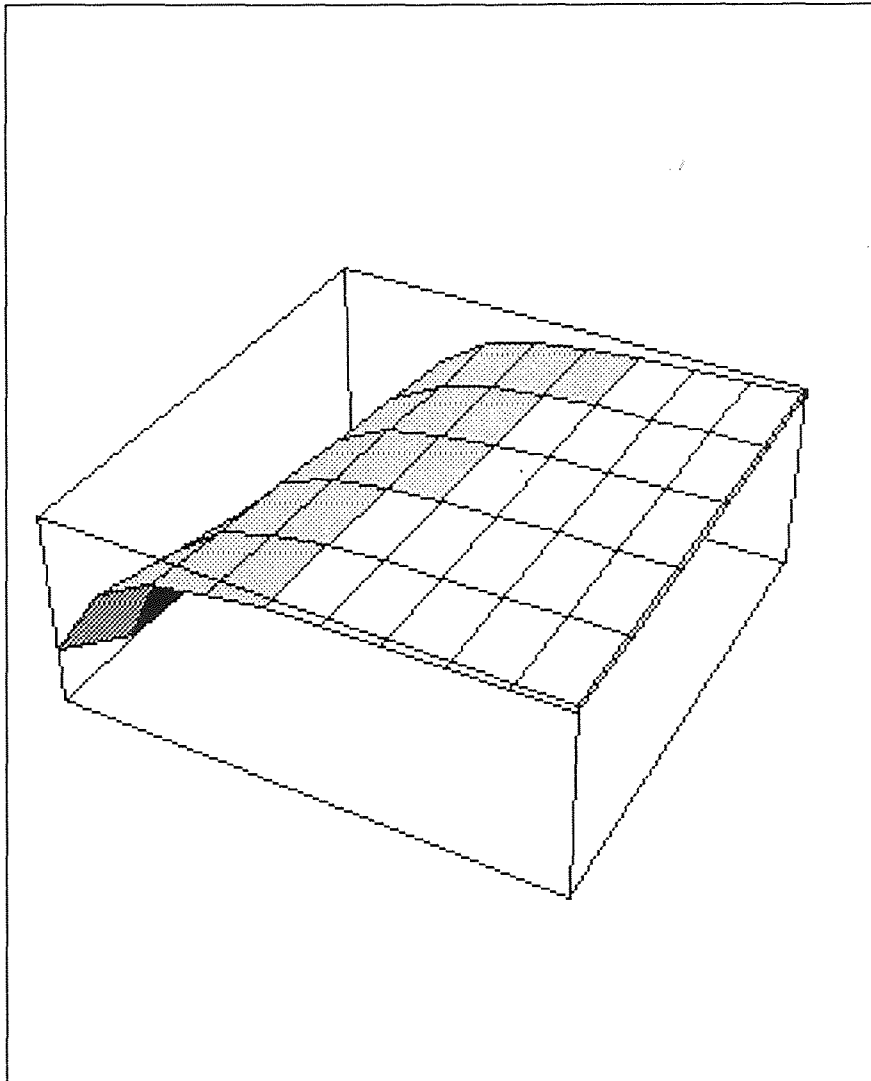

**Figure 5** Three dimensional representation of stress in depth and radius for the laser radiation. Radius increases to the lower right, depth to the upper right and stress vertically.

B) Stress is function of laser power and  
radius(3-Dimensions)

Stress-p-r

depth=0.1 cm (constant)



**Figure 6** Three dimensional representation of stress in power and radius for the laser radiation. Power increases to the upper right, radius to the lower right and stress vertically.

## CHAPTER 4

### EXPERIMENTAL PROCEDURE

1. Manufacturing cement by using the compositions of saurizing, saurizing liquid, frit and tin oxide in different ratios.

a) Dry Mixing

Mix the saurizing powders, frit and tin oxide to obtain the exact consistency required for making.

b) Add Saurizing Liquid

Add saurizing liquid to the dry mixed body. Liquids are used in ceramic processing to wet the ceramic particles and provide a viscous medium between them and to dissolve compounds in the system. The admixed liquid changes the state of dispersion of the particles and the mechanical consistency.

A surfactant is a substance added to reduce the surface tension of the liquid or the interfacial tension between the surface of the particles and the liquid to improve wetting and dispersion, we consider the composition and properties of water, nonaqueous liquids, and surfactants used in ceramic processing.

Water is the major liquid used in ceramic processing, and it is often refined to improve its purity or consistency. It is a polar liquid and has a high dielectric constant and surface tension relative to other liquids. It is a good solvent for polar and ionic compounds. Water can form a hydrogen bond with substances containing an -OH or -COOH group. The viscosity of water decreases significantly on heating from 20 to

50°C. Nonaqueous liquid systems are less polar in nature and are good solvents for relatively nonpolar substances; their solutions provide greater ranges in properties. The liquid system used must dissolve additives yet permit their adsorption at interfaces to assist in dispersion. Surfactants are effective in very small concentrations, and when added in excess of that required for adsorption, clusters of surfactant molecules called micelles form in the solution. Above the critical concentration at which clusters form, the surface tension and refractive index exhibit a different dependence on surfactant concentration above the critical micelle concentration.

2. Apply cement to the tile defect and tile the cement flat (surface quality). The surface quality plays a very important role in radiation processing because atoms and molecules at surfaces may have unsatisfied chemical bonds that produce a surface tension that modifies the behavior of a material. The surface behavior is altered by surface curvature (smoothing) and material adsorbed on the surface. The cement surface must lie flush with the existing tile surface and/or allow itself to be filled, so the surface can be defined as: rough, medium and perfect smooth. We strongly prefer perfect smoothing surface. Rough surface causes bigger surface tension and makes crackings on the surface.

3. Dry cement in room temperature for 12 hours until cement is hardened. Drying is the removal of liquid from a porous material by means of its transportation and evaporation into surrounding unsaturated gas. It is an important operation prior to firing in processing bulk raw materials. The evaporation of processing liquids is relatively energy-intensive and drying efficiency is always an important consideration. Drying must be carefully controlled because stresses produced by differential shrinkage may



cause defects in the product. Sometimes cracks may appear during drying. If it is dried too quickly so that stresses are introduced while the body is shrinking, then failure may occur under a very small load. The longer drying time, the better microstructure. For example, for the points of the tile #Y1, #Y8, #Y9, #Y10, the drying time is more than 24 hours, good microstructures are obtained. For some points that have the same composition as the point #9, #10 of tile #Y1. On the other hand, for the points of the tile #Y6, only 10 minutes drying time by using heating gun, cracking surfaces appear during radiation.

#### 4. Polish

5. Make up a glaze using frit and water, the glaze solution was made from the frit that was also used to formulate the cement. Typical mixing ratio 75.5:24.5 of weight, variable until glaze formulation is a liquid.

The purpose of applying a glaze to ceramic article:

- 1) to provide an impermeable surface to a body which is otherwise porous and permeable
- 2) to provide a smooth surface which is easily kept clean
- 3) to enhance appearance
- 4) to protect underglaze decoration from abrasion or chemical attack or to provide a surface on which a glaze decoration may be applied and shown to best advantage.

Glazing is a process of covering the body with a thin layer of glass. A suspension of the finely ground constituent glaze materials is applied to the body which then dried and fired. The glassy state is developed during firing. Glaze is usually applied in aqueous suspension to the dried cement in the case of once fired ceramics. Application

may be by hand dipping. After drying, the cement is fired when the glaze melts and on cooling solidifies into a glass. The ceramic glaze is a special glass or glass-crystal mixture applied in a thin layer to the body. This layer is so thin that surface properties, both glaze-air and glaze-body interfaces, become as important as the bulk properties.

Surface tension is defined that an atom or molecule in the interior of a liquid is acted on by forces closely equal on all sides. The same atom on the surface, however, is acted on by forces only from one hemisphere which causes the surface to be in tension like a stretched, elastic membrane. The tendency is to reach a shape of minimum surface, so the surface tension has an important bearing on the ability of a glaze to smooth out into an even surface. On the other hand, a high surface tension can readily cause the condition known as crawling if fine drying cracks divided the glaze layer into small areas.

In this case each area will draw together and finally become a sphere, thus achieving a minimum surface in another way. In general, the thicker the glaze layer, the slower will be the bubble removal; and conversely, the lower the glaze viscosity, the more rapid the action will be. Good glaze/body match is the most decisive element contributing to satisfactory thermal shock resistance. The glaze should be under compression on cooling. The higher the compression of the glaze, the better the thermal shock resistance. A perfect body microstructure can be ineffective if the body is covered with a glaze which is under tension or under insufficient compression. On the other hand, a "poor" body, having relatively large/high thermal expansion--quartz crystals, a high glass content and an unsatisfactory texture (i.e. defects) may produce

good thermal shock resistance if coated with a suitable, low thermal expansion glaze.

It is that a low thermal expansion of the glaze is achieved by a strongly bonded structure, brought about by high silica and alumina contents and a high alkaline earth/alkali ratio.

6. Allow glaze to dry naturally and ensure that glaze coating is made up of thin brush shakes.

7. Radiate cement with CO<sub>2</sub> laser.

8. Cooling

When cooling products containing a glassy matrix, it is common practice to cool slowly through the glass transition temperature, to anneal stresses in the glass produced by thermal gradients. Slow cooling is also necessary when a crystalline phase undergoes a transformation causing a large change in volume, such as the thermal inversion of quartz at 573°C and cristobalite at 220-280°C. Stresses of sufficient magnitude caused by differential thermal contraction produce small cracks in the product or complete failure. Tensile stress in a glaze produced by a differential contraction between the glaze and substrate may produce fine cracks in the glaze, a glaze defect called cracking. A high compressive stress may cause peeling.

## CHAPTER 5

### RESULTS AND DISCUSSIONS

ALL glazes provided by American Standard were tested for an ability of withstand laser treatment when coated on to a glazed tile. Using the radiation protocol is found that it was possible to fire a glaze without any signs of flaws or cracks. In order to repair the flawed ceramic material it is necessary to patch the undamaged region with a cement. The cement must then be glazed in order to match that of the undamaged portion of the ceramic material. The cements require the following properties:

- 1) The cement must adhere to the ceramic material.
- 2) The cement must form a smooth surface that allows the glaze to flow freely.
- 3) The composition of the cement must be easy to apply to the damaged area.
- 4) The cement surface must lie flush with the existing ceramic surface and allow itself to be filed.
- 5) The cement must have the ability to withstand intense localised heat without cracking.
- 6) The applied glaze must adhere to the base cement.

### **5.1 Experiments With Saureusen Cement and Saureusen Liquid and frit and Tin Oxide**

This combination has proved to be a winner through I am in the process of ascertaining the best frit material. This material when used in the ratio of 1:1:0.4:1 gives the right adhesiveness to the base tile and forms a hard glazed surface which matches with the tile. However we need to work on a surface irregularity which is perceptible when felt with the hand. The estimation of the shrinkage of the material after glazing still needs to be looked into. The success is to the extent of forming a hard coherent filled defect area which does not peel off on scratching or physical abuse to the tile. I am still working on the choice of the right frit which will make the surface lie flush with the tile so as to make the surface cosmetically appear unblemished or irregular. A low melting frit should do this job.

### **5.2 Experiments With Color Match of the Base Material**

A perfect color match with the base material has been established by extensive experimentation with different weight percentages of tin oxide mixed with the frit material. Most of the experimentation has been done on the frits F49, 376, 268D, FZ30. When mixed with saureusen cement and frit the optimum amount of the tin oxide needed has been found out to be 20% of the total amount of frit + cement. Experiments have been conducted with tin oxide percentages of 3%, 5%, 7%, 8%, 10%, 12%, 15%, 20%, 30%, 40% and 50%.

### **5.3 Experiments on the Change of Flux of the Laser Beam With Time**

It had been established earlier that a good glaze is obtained when the flux of the laser radiation is varied with time instead of radiating with a constant flux. Accordingly experiments were conducted so as to standardize on the power of the beam and how to change the flux of the laser beam with time. The radiation process consists of a heating cycle, until I reach the point of maximum power density.

Experiments were conducted to determine the effect of change of dwell time at the maximum power density. The best results were obtained with a dwell time of 0.4 second. Experiments were also conducted on the effect of the cooling rate on the radiated area. Best results were obtained with a cooling time of 2.5 second (with a beam diameter of approximately 4 mm).

## CHAPTER 6

### CONCLUSIONS

Lasers are rapidly gaining importance as tools in the manufacturing industry. Once a particular application is developed, requirements of improved quality drive the research in the direction of refinements in the process. This study investigated the feasibility of using surface temperature as a tool to control laser process. This study also investigated laser treatment as a tool to repair the defective ceramic coating tile. Therefore, as a first step in this study, particular attention was placed study on studying the theories that surface temperature and stresses(strains) correlate with the quality of a laser process. A simple CO<sub>2</sub> gas laser surface melting process may achieve a surface repairing of ceramic coating. However, random microcracking lowers the mechanical properties and corrosion resistance. To achieve both thermal and mechanical barriers requires a kind of particular ceramic paste. This paste has physical and chemical properties very similar to those of the substrate and accomplishes this laser process with a minimal loss of production.

**APPENDIX 1**

Temperature is function of radiation time and

radiation depth(3-Dimensions)

diameter = 0.41142 cm (constant)

power = 12 watts (constant)

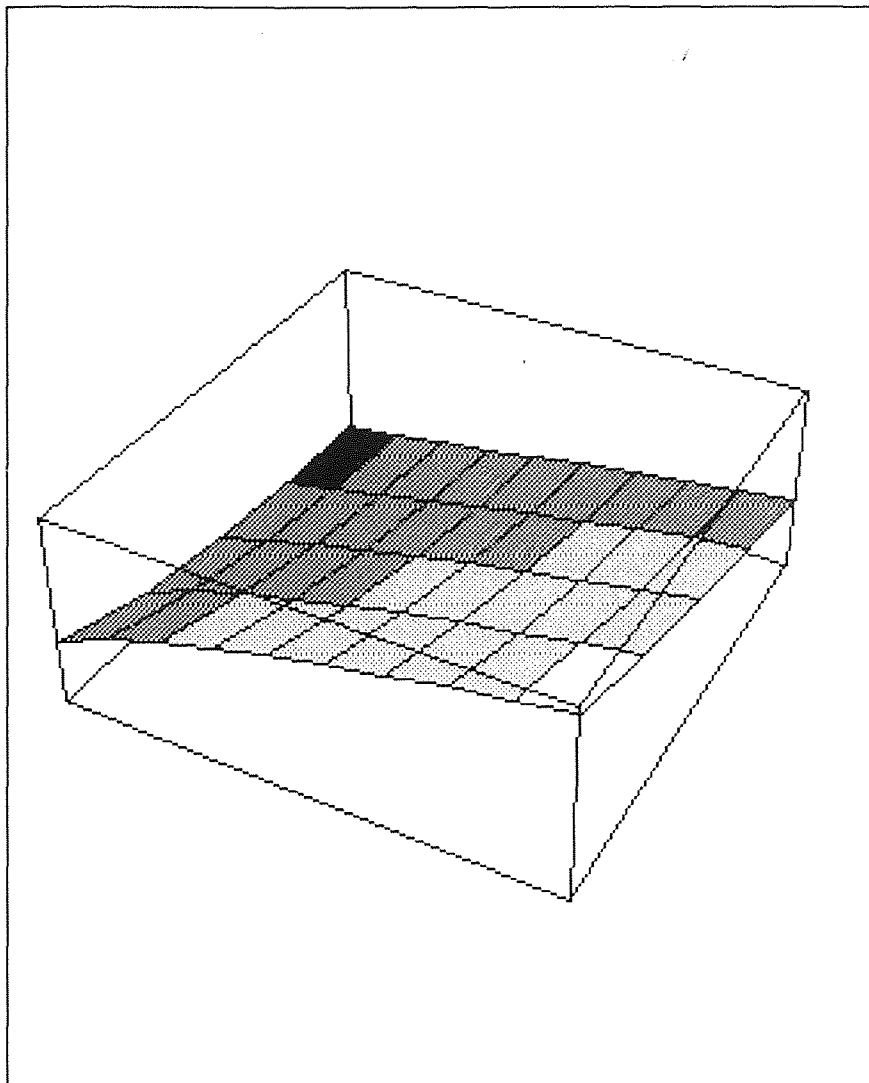

Three dimensional representation of temperature in radiation time and radiation depth for laser radiation. Time increases to the lower right, depth to the upper right and temperature vertically.



**APPENDIX 2**

Temperature-time family(2-Dimensions)

power = 12 watts

diameter = 0.41142 cm

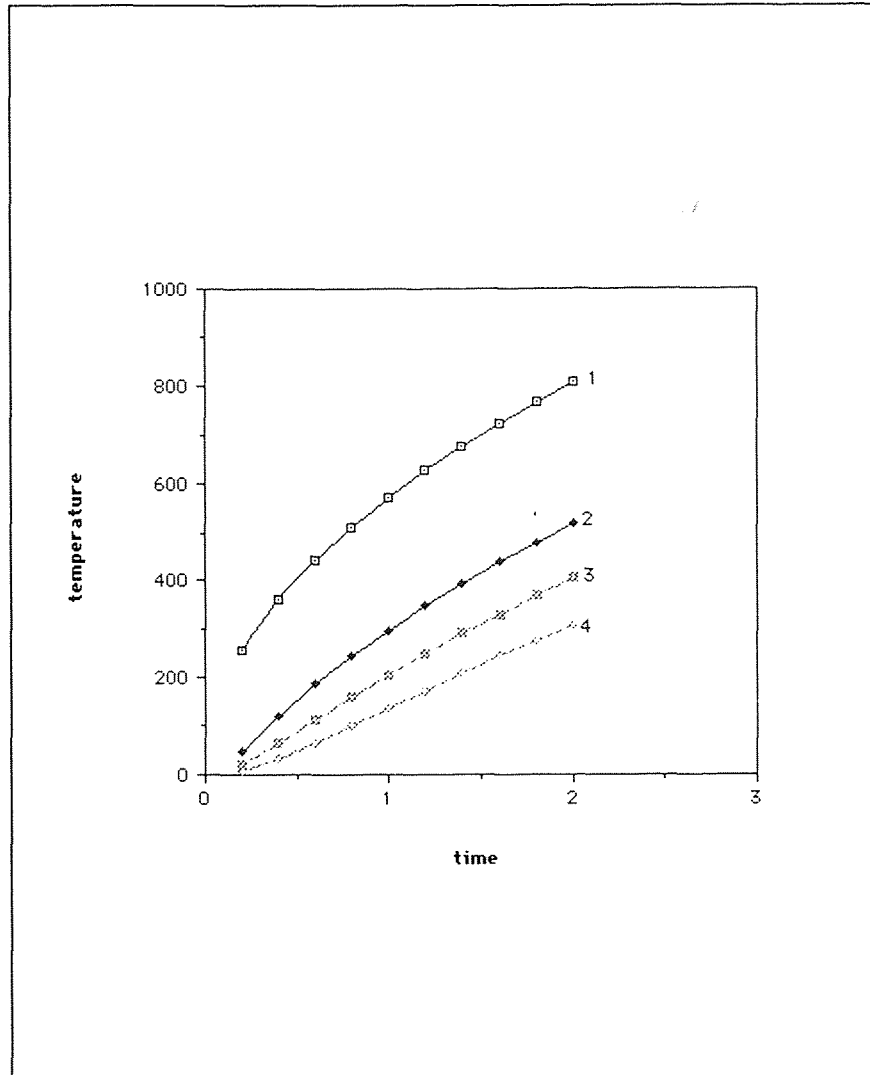

#1 depth=0.00 cm(surface)

#2 depth=0.10 cm

#3 depth=0.15 cm

#4 depth=0.20 cm

Typical temperature versus time curve for Guassian laser beam.

## APPENDIX 3

Stress-r family(2-Dimensions)

Stressrr-r

power = 12 watts

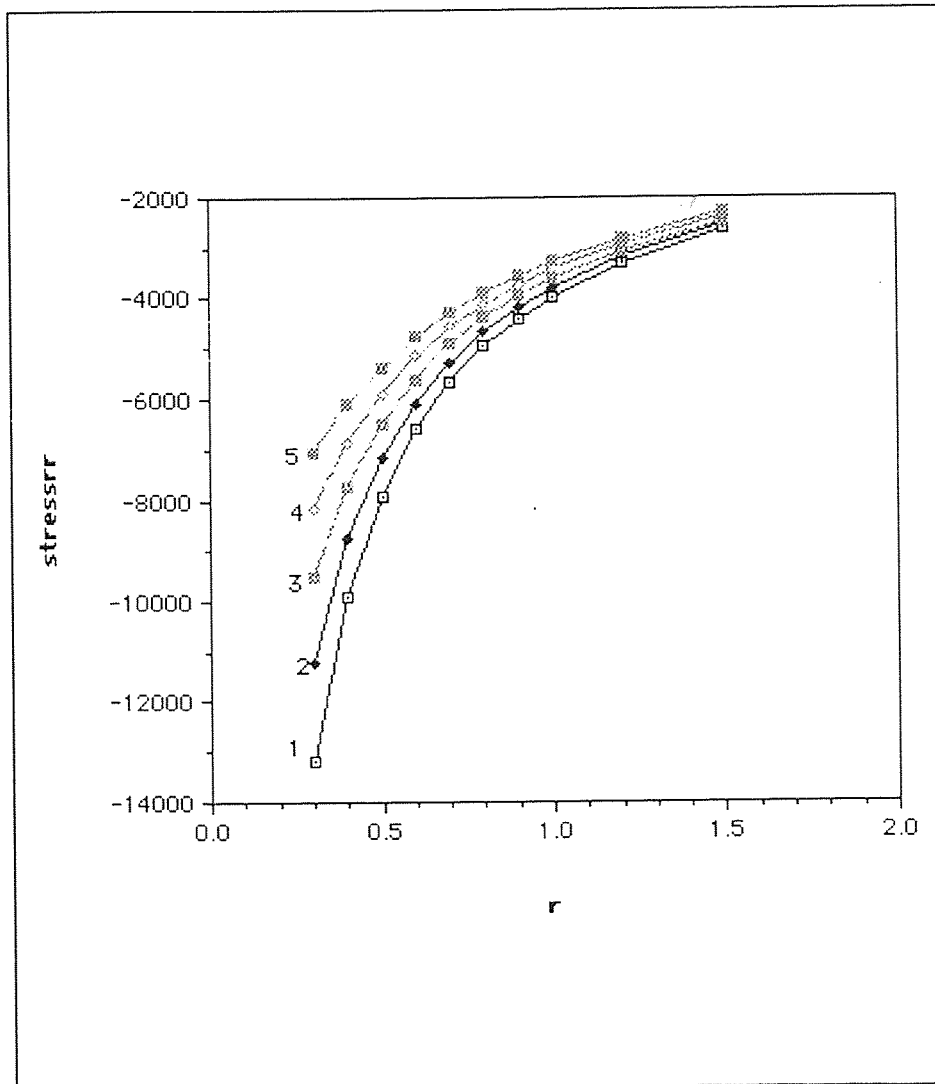

#1 depth = 0.00 cm (surface)

#2 depth = 0.05 cm

#3 depth = 0.10 cm

#4 depth = 0.15 cm

#5 depth = 0.20 cm

Typical stress in rr direction versus radius curve for Gaussian laser beam radiation.

## APPENDIX 4

Stress<sub>qq-r</sub>

power=12 watts

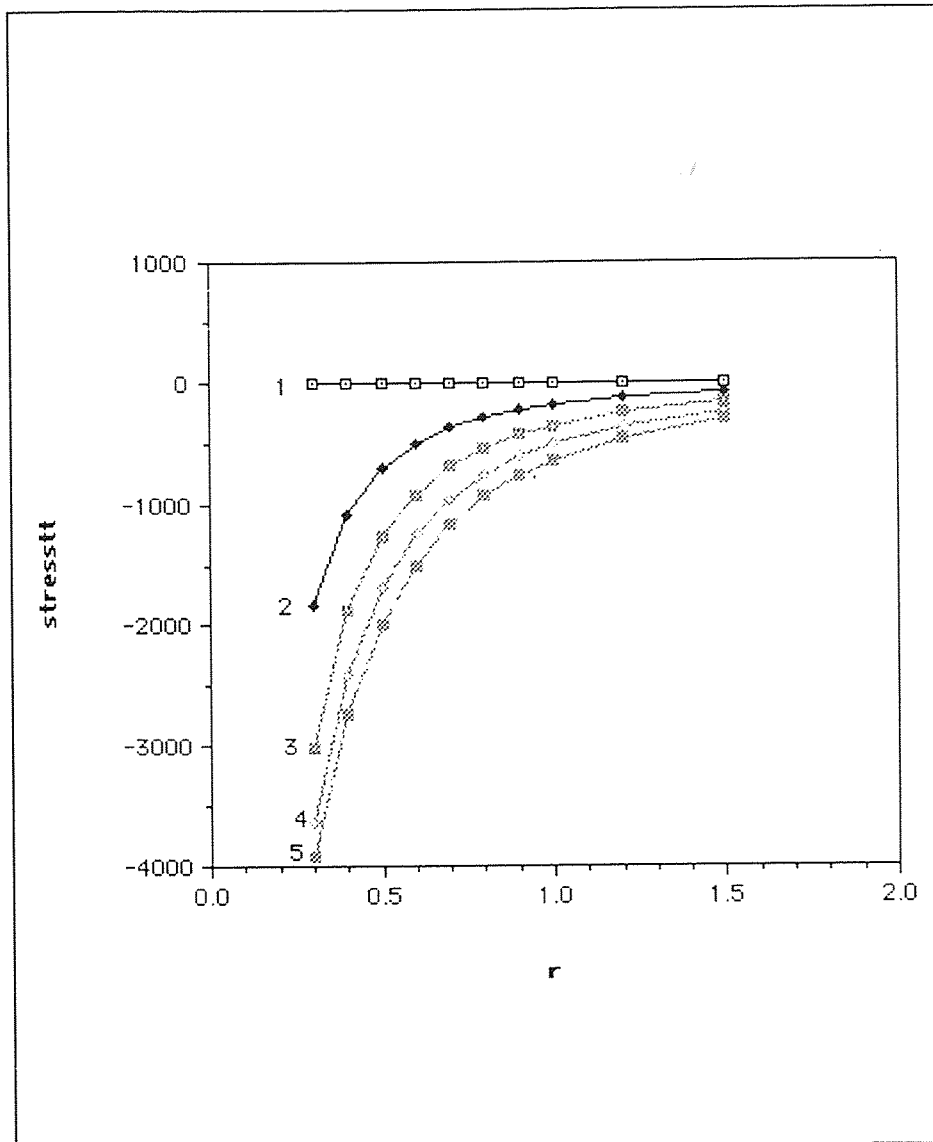

#1 depth = 0.00 cm (surface)

#2 depth = 0.05 cm

#3 depth = 0.10 cm

#4 depth = 0.15 cm

#5 depth = 0.20 cm

Typical stress in qq direction versus radius curve for Gaussian laser beam radiation.

## APPENDIX 5

Stress<sub>zz</sub>-r

power=12 watts

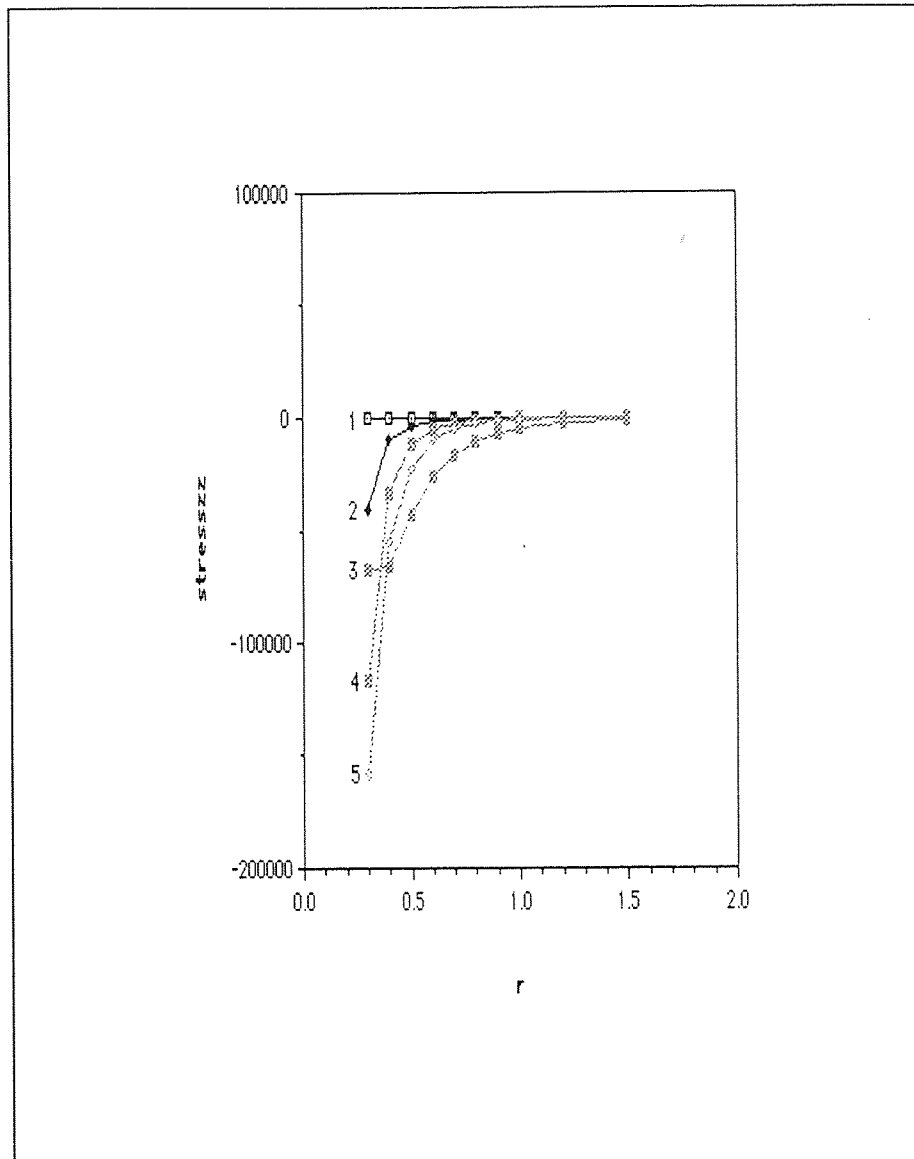

#1 depth = 0.00 cm ( surface )

#2 depth = 0.05 cm

#3 depth = 0.10 cm

#4 depth = 0.15 cm

#5 depth = 0.20 cm

Typical stress in zz direction versus radius for Gaussian laser beam.

## APPENDIX 6

Stress<sub>rz</sub>-r  
power=12 watts

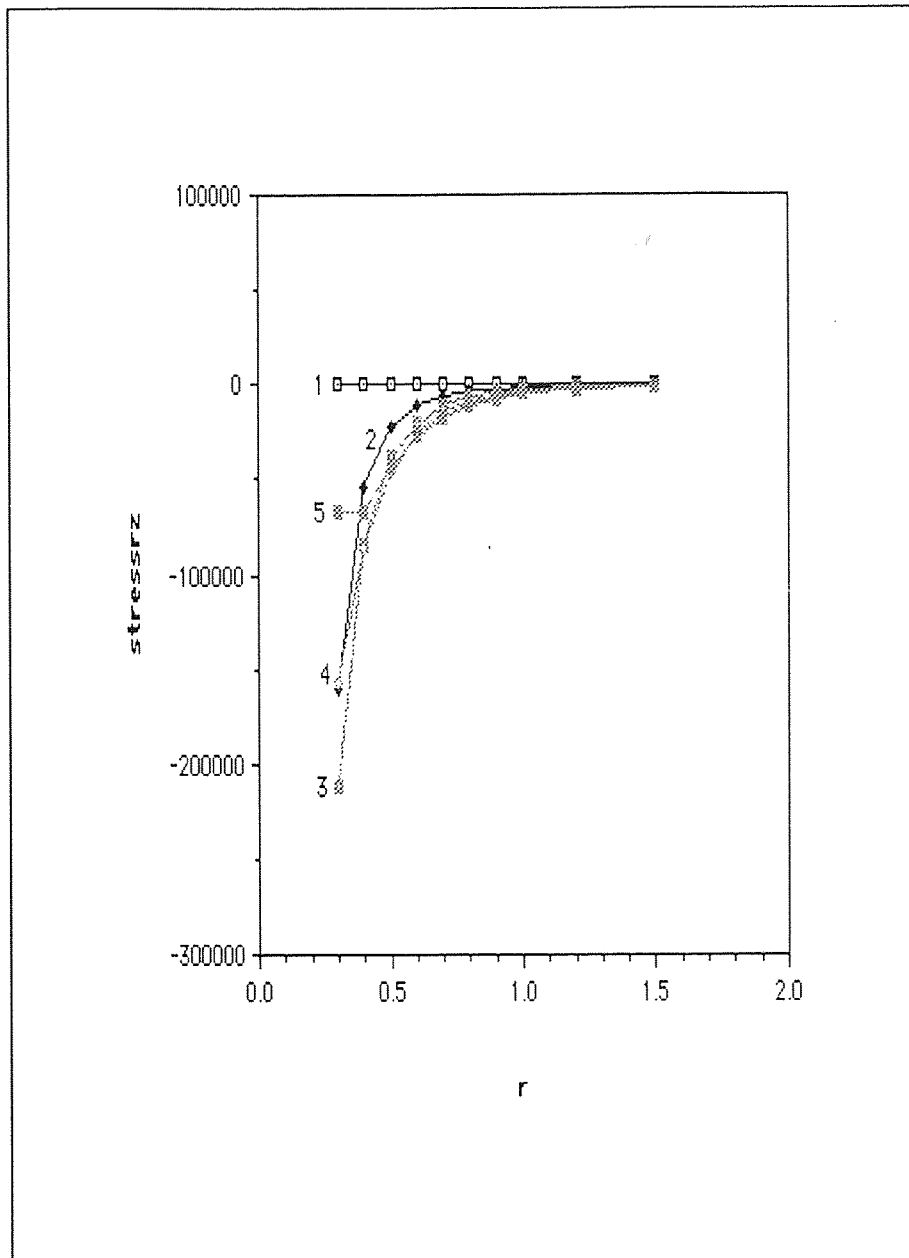

#1 depth = 0.00 cm

#2 depth = 0.05 cm

#3 depth = 0.10 cm

#4 depth = 0.15 cm

#5 depth = 0.20 cm

Typical stress in rz direction versus radius for Gaussian laser beam.

## REFERENCES

- Abboud, H. J. and D. R. West. 1989. Ceramic Metal Composite. New York: Academic Press.
- Duley, A. 1976. CO<sub>2</sub> Lasers Effects and Application. New York: Academic Press.
- Hove, J. E., and W. C. Riley. 1965. Modern Ceramic. New York: Wiley.
- Petitbon, A. and D. Guignot. 1989. Materials Science and Engineering. New York: North-Holland Publishing Company.
- Rado, Paul. 1988. An Introduction to the Technology of Pottery. New York: Plenum
- Rajendran, N. and B. M. Pate. 1990. "Real-Time Laser Materials Processing Control." *Journal of Applied Physics*. 87: 119-129.
- Reed, S. James. 1988. Introduction to the Principles of Ceramic Processing. Cambridge: Cambridge University Press.
- Rukavina, Mitchell. 1990. Rock Products. New York: Academic Press.
- Ryan, W. 1968. Properties of Ceramic Raw Materials. New York: McGraw-Hill.
- Welsh, P. Lisa, Tuchman A. Judah, and Irving P. Herman. 1988. "Laser Materials Processing." *Journal of Applied Physics*. 64: 11-13.
- Yi, J. L. Jay and Peter R. Strutt. 1990. "Surface Modification of SiO<sub>2</sub> Glass By Laser Processing." *Journal of Non-Crystalline Solids*. 120: 283-287