

Copyright Warning & Restrictions

The copyright law of the United States (Title 17, United States Code) governs the making of photocopies or other reproductions of copyrighted material.

Under certain conditions specified in the law, libraries and archives are authorized to furnish a photocopy or other reproduction. One of these specified conditions is that the photocopy or reproduction is not to be “used for any purpose other than private study, scholarship, or research.” If a user makes a request for, or later uses, a photocopy or reproduction for purposes in excess of “fair use” that user may be liable for copyright infringement,

This institution reserves the right to refuse to accept a copying order if, in its judgment, fulfillment of the order would involve violation of copyright law.

Please Note: The author retains the copyright while the New Jersey Institute of Technology reserves the right to distribute this thesis or dissertation

Printing note: If you do not wish to print this page, then select “Pages from: first page # to: last page #” on the print dialog screen

The Van Houten library has removed some of the personal information and all signatures from the approval page and biographical sketches of theses and dissertations in order to protect the identity of NJIT graduates and faculty.

ABSTRACT

Design of an Autonomous Vehicle System

Fritz Gerald Momplaisir

With advances in electronics, mobile vehicles are becoming more and more sophisticated. The potential applications of AGVs are numerous an range from a material handling system for the factory floor to an intelligent wheel chair for the handicapped. The design of these vehicles, however, remains a difficult task. Even when the machine is given precise information about its environment, the fact that it is never free of noise further complicate the situation. One of the goals of an AGV project is to design a robust system that will operate efficiently in the presence of different sources of noise.

The scientific of mobile robotics is still evolving, there is no set method to design such a system. In this thesis, we will provide the guidelines and in some cases the necessary information to design an autonomous vehicle.

We will concentrate on the practical side of designing. This includes the various techniques utilized in developing an autonomous vehicle at New Jersey Institute of Technologies' Center for Manufacturing Systems.

DESIGN OF AN AUTONOMOUS VEHICLE SYSTEM

by
Fritz Gerald Momplaisir

**A Thesis
Submitted to the Faculty of
New Jersey Institute of Technology
in Partial Fulfillment of the Requirements for the Degree of
Master of Science in Manufacturing Systems Engineering**

Manufacturing Engineering Division

January 1994

Blank Page

APPROVAL PAGE

DESIGN OF AN AUTONOMOUS VEHICLE SYSTEM

Fritz Gerald Momplaisir

Dr. Raj Sodhi, Thesis Advisor Date
Associate Professor of Mechanical Engineering and
Director of Manufacturing Engineering Programs, NJIT

Dr. Zhi Ming Ji, Committee Member Date
Assistant Professor of Mechanical Engineering, NJIT

Dave Lubliner, Committee Member Date
Associate Director of the Simulation Lab,
Center for Manufacturing Systems, NJIT

BIOGRAPHICAL SKETCH

Author: Fritz Gerald Momplaisir
Degeee: Master of Science in Manufacturing Systems Engineering
Date: January 1994

Undergraduate and Graduate Education:

- Master of Science in Manufacturing Systems Engineering,
New Jersey Institute of Technology, Newark, New Jersey, 1994
- Master of Science in Industrial Management,
State University of New York at Stony Brook, Stony Brook, New York, 1991
- Bachelor of Engineering in Mechanical Engineering,
State University of New York at Stony Brook, Stony Brook, New York, 1989

Major: Manufacturing Systems Engineering

*This Thesis is Dedicated to my father
who gave me the necessary foundation
to succeed in life*

ACKNOWLEDGMENT

I wish to express my sincere gratitude to my academic and thesis advisor Dr. Raj S. Sodhi for his support and understanding during my stay at NJIT.

I also wish to thank David Lubliner whose advice and guidance were instrumental in the successful accomplishment of this thesis.

Special thanks to all the members of the design team that developed, built and tested the Autonomous Vehicle in conjunction with David Lubliner.

TABLE OF CONTENTS

Chapter	Page
1 INTRODUCTION.....	1
1.1 System Overview.....	2
2 PRELIMINARY DESIGN CONSIDERATIONS.....	4
2.1 Loading Considerations.....	4
2.2 Mainframe Material.....	4
2.3 Drive and Steering.....	5
2.3.1 Separate Drive and Steering Motors.....	5
2.3.2 Combined Drive and Steering Operation with Two Motors.....	6
2.4 External Response Mechanism.....	7
2.5 External Sensing Mechanism.....	8
2.6 Internal Response and Sensory Mechanism.....	8
2.7 Internal Control Mechanism.....	9
2.8 Power Supplies.....	9
3 ELECTRONIC HARDWARE FOR ROBOTICS SYSTEMS.....	11
3.1 Circuit Elements.....	11
3.1.1 Different Type of Semiconductor.....	11
3.1.2 Transistors.....	13
3.2 Working with Gates.....	15
3.3 FETs and MOSFETs.....	17
4 BATTERIES AND POWER SUPPLIES.....	18
4.1 Different Type of Batteries.....	19
4.2 Battery Selection.....	20
4.3 Lead Acid Batteries Design Specifications.....	21
4.3.1 Estimating the Average Current Demand.....	21

TABLE OF CONTENTS
(Continued)

Chapter	Page
4.4 Selecting Battery Charger Systems.....	23
4.4.1 Battery Recharge Characteristics.....	24
4.4.2 Charging more than One Battery.....	25
4.5 Power Distribution Systems.....	28
4.5.1 Fuse Protection.....	30
4.5.2 Auxiliary Power Supplies.....	31
5 SENSORS FOR AUTONOMOUS VEHICLE SYSTEMS.....	33
5.1 Motor Speed Sensing Mechanisms.....	33
5.1.1 Optical Motor Speed Sensing.....	33
5.1.2 Electromechanical Speed Sensing.....	36
5.2 Sensing Current and Voltage.....	37
5.2.1 Voltage Sensing.....	37
5.2.2 Current Sensing.....	37
5.3 Vision Sensors.....	39
5.3.1 Two Dimensional Sensors.....	39
5.3.2 Stereo Vision.....	40
5.3.3 Optic Flow.....	41
5.4 Range Measuring Sensors.....	42
5.4.1 Scanning Optical Range Finders.....	42
5.4.2 Static Range Finders.....	43
5.4.3 Ultrasonic Range Finders.....	43
6 DC MOTORS.....	45
6.1 Motor Specifications.....	45

TABLE OF CONTENTS
(Continued)

Chapter	Page
6.1.1 Operating Characteristics of a Motor.....	45
6.1.2 Motor Torque and Mechanical Power.....	46
6.2 Estimating the Mechanical Requirements of Motors.....	48
6.2.1 Mechanical Power and Torque.....	48
6.2.2 Motor RPM.....	49
6.2.3 Determining the Useful Torque.....	50
6.2.4 Motor Gear Arrangement.....	51
6.3 Motor Circuit and Direction Control.....	52
6.3.1 Introduction to Relays.....	53
6.3.2 Two Direction Control Using Relays.....	55
6.3.3 Two Direction Drive Steering Control Circuit.....	56
7 CONCLUSION.....	58

LIST OF TABLES

Table	Page
2.1 Two Motor Drive Steer Operations Table.....	7
4.1 Wire Size as a Function of Peak Current.....	29
4.2 Blowing Characteristic of Small Glass Fuses.....	31
6.1 Function Table for the Two Direction Motor Control Circuit Using Relays.....	56
6.2 Function Table for the Two Direction Two Drive Steer Control Circuit.....	57

LIST OF FIGURES

Figure	Page
1.1 AGV System Block Diagram.....	2
2.1 Drive and Steer Configuration.....	6
3.1 Rectifier Diode.....	12
3.2 Bipolar Transistors.....	13
3.3 Circuit with an NPN Transistor.....	14
3.4 Basic Gate Configuration.....	15
3.5 Structure of Bipolar Transistors, FETS and MOSFETs.....	16
4.1 Charging Curve for a One Battery System.....	24
4.2 Power ON Recharging.....	26
4.3 Recharging More than One Battery.....	27
4.4 A Power Distribution Scheme.....	29
5.1 Optical Sensor Arrangement.....	34
5.2 Circuit for Operating an Optical Motor Speed Sensing System.....	36
5.3 A Circuit for Translating a Current Level into a Proportional Voltage Level.....	37
5.4 A Hall Effect Current Sensing System.....	38
5.5 Stereo Imaging Diagram.....	40
5.6 Ultrasonic Sensor Functional Block Diagram.....	44
6.1 Motor Gear Arrangement.....	51
6.2 Motor Relay Interface in a Basic Circuit.....	53
6.3 Controlling a Motor Relay with a Transistor.....	54
6.4 Two Direction Motor Control Circuit with Transistors and Separate Logic Supply Voltage.....	55
A.1 Drive and Steering Configuration Using Separate Motors for Steering and Driving..	59
A.2 Rectifier Action and Avalanche Action of a Semiconductor.....	60

LIST OF FIGURES
(Continued)

Figure	Page
A.3 Generalized Block Diagram of a Scanning Lazer Range Finder.....	61
A.4 A Generalized Block Diagram of a Vision Sensor.....	62
A.5 Two Direction Drive Control Circuit.....	63

CHAPTER 1

INTRODUCTION

The primary focus of robotics since its inception in the 1960s has been on the design and control of manipulators. Industrial needs at the time motivated this trend in robotics research and development. Recently, more and more attention has been devoted to the field of mobile robotics. This reflects the increasing popularity of these vehicles in the world today.

A mobile robot is a machine that in some instances demonstrate behavior that is similar to a robot. However, it lacks the necessary autonomy. These vehicles are either directly controlled by a human operator or indirectly by a special computer program.

In order to maneuver within a given environment, an autonomous vehicle must be capable of: 1) Sensing its environment. 2) Refine the knowledge of its position by interpreting the information provided by its sensors. 3) Design a path from its original location to a destination in the presence of obstacles

In this project we will attempt to develop a design for the major component of an autonomous vehicle system, including the power distribution system, the motors and the various sensors. The various procedures that results from this work will lead to the proper selection of the various constituents of an autonomous vehicle.

Autonomous vehicle design incorporate works in the fields of mechanical, electrical and electronic engineering. Furthermore, it also involves computer science and programming in the case of second and third generation robots. We had to gather information from these different fields in order to develop this thesis.

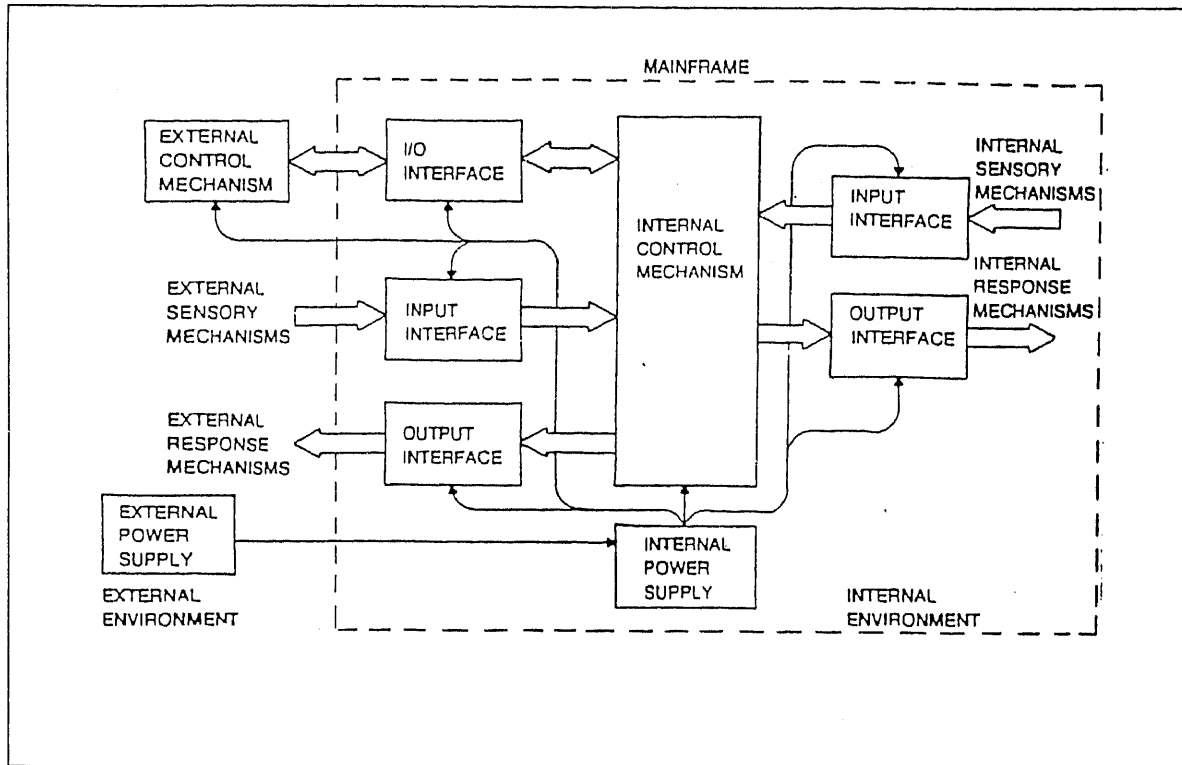

Figure 1.1 AGV System Block Diagram. [2]

1.1 System Overview

Figure 1.1 presents the overall system diagram for an autonomous vehicle. We are going to elaborate next on the various components of that system.

The mainframe house all the electrical and mechanical subsystems, it supports the framework of the machine.

The internal power supply provide electrical power to the internal electrical circuits and the external response mechanisms. In case the machine is moving on its Own, a couple of power supply is usually used. One battery is dedicated to the motors while the other takes care of the electronic circuits.

Internal response mechanisms influence the internal environment of the machine. These devices may have an indirect impact on the external environment.

External response mechanisms are responsible for responses that change the external environment of the vehicle. Motors are one of the principal external response mechanism, they allow machine motion and modify directly the external environment.

Internal sensory mechanisms monitor the internal environment of the vehicle. An example of this type of mechanism is a device that senses the voltage of the battery.

External sensory mechanism monitor the external environment of the machine. Sensors that trigger a signal to stop the machine in the presence of an obstacles are primary examples of external sensory mechanism.

Internal control mechanisms is central to all activities within the vehicle. It processes input and output devices and control their operation. These mechanisms, are also responsible for logical decisions that affect the internal environments and trigger changes in the external environment of the machine.

External control mechanisms are devices in the outside environment of the robot that directly control its activities.

Input interface mechanisms alter the electrical signals from the internal and external sensory mechanism in order to make them compatible with the internal control mechanism signals. Output interface mechanisms on the other hand process signals from the internal control mechanism in order to make them compatible with the internal and external response mechanisms.

CHAPTER 2

PRELIMINARY DESIGN CONSIDERATION

2.1 Loading Considerations

The battery is the heaviest component of the system, its position dictates the location of the center of gravity. It should, therefore, be placed at the lowest possible position in the mainframe assembly. Motors can be bulky in larger machines, they may also influence the weight distribution and stress on the mainframe.

After the placement of such heavier subsystem; the smaller parts of the vehicle can be placed, using the following guidelines.

- All the circuit, boards must be kept at least a couple of inches away from the batteries.
- Circuit boards must be fixed and secured to the frame.
- In case a proximity type sensor is used, it should be placed such that it cannot come in direct contact with the outside environment.
- The different components should be placed so that they can be easily accessible in case they need to be fixed or replaced in the future.
- Long cables should be fixed to the frame.[2]

2.2 Mainframe Material

Wood is one of the first options for building material. It can be machined easily, however a problem with wood is that it is heavier than plastic or aluminum. It is also a poor conductor of heat; dissipating heat is of primary importance for motors and other electronic devices. Another disadvantage in using wood is that it contract and expand with changes in temperature and humidity, this could cause serious damage to microprocessors and other expensive electronic hardware.

While plastic can be used for minor subsystems, it should not be selected as mainframe material. Just like wood it is a poor conductor of heat, it is also a brittle material which will tend to crack at the first collision.

Aluminum on the other hand is a very good conductor of heat, it is strong and doesn't weigh much. Furthermore, it does not pick up any magnetic field. The only drawback in using Aluminum is that it is a very good conductor of electricity. Therefore, all electrical contacts must be insulated in case this material is used.

2.3 Drive and Steering

The drive and steering mechanism is of primary importance in the design of the mainframe. It practically dictates the type of response and sensory mechanism required for operating the motors. Different types of drive and steer format are going to be considered in the following section.

2.3.1 Separate Drive and Steering Motors

In this type of configuration a gear motor controls the steering of the vehicle, it turns the front wheels a number of degrees left or right. The maximum steering angle limits the turning radius of the system. This turning radius is dictated by the arrangement of the steering unit and the load distribution of the vehicle.

In case such a system is used for an automatically controlled vehicle, the two steering limits and the center position must be monitored by a sensing device. In order to achieve finer automatic steering, additional position sensor can be used at different degree increments along the turning radius.

Figure A.1 in the appendix presents a drive and steering configuration That uses separate motors for steering and driving. In this case the two motors drive just one wheel, and the other two wheels are idle.

The steering motor allow the vehicle to turn left and right. With the proper placement of the center of gravity, the front wheel can be rotated 180 degrees in either direction [2].

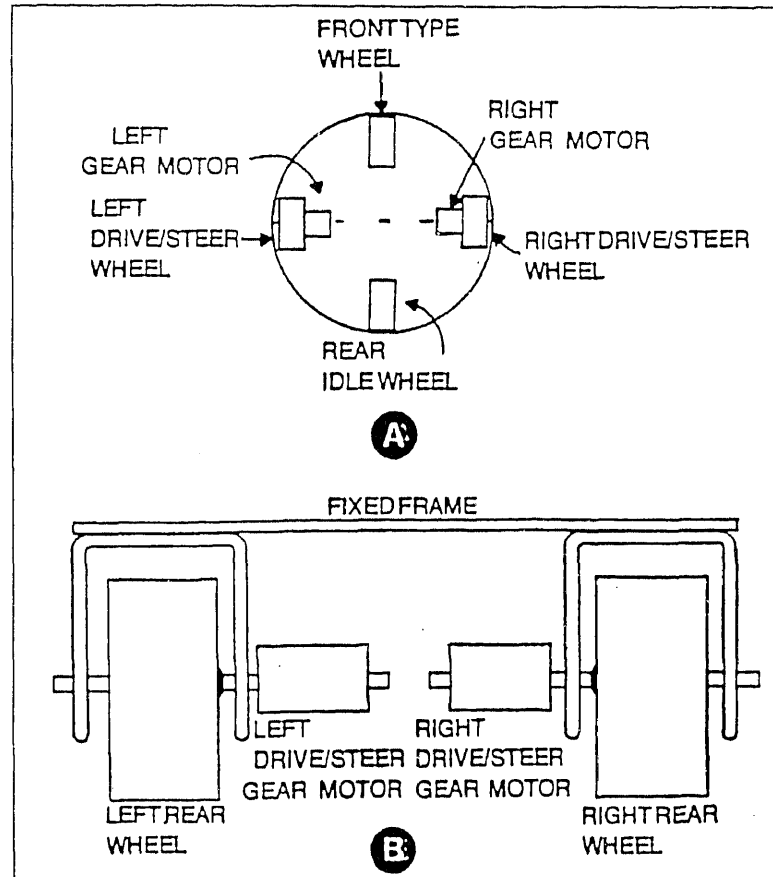

Figure 2.1 Drive and steer configuration.[2]

2.3.2 Combined Drive and Steering Operation with Two Motors

This driving and steering arrangement presented in figure 2.1 is the most popular among AGV designers. The two motors are mounted on the left and right wheels. They are simple drive gear motors capable of forward and reverse motion. When used simultaneously these two motors are also capable of steering the vehicle. Table 2.1 summarizes the drive steer operation of this arrangement.

Table 2.1 Two motor drive/steer operations table.

LEFT MOTOR	RIGHT MOTOR	SYSTEM RESPONSE
STOP	STOP	STOP
STOP	FORWARD	FORWARD LEFT TURN
STOP	REVERSE	REVERSE, LEFT TURN
FORWARD	STOP	FORWARD, RIGHT TURN
FORWARD	FORWARD	FORWARD
FORWARD	REVERSE	CLOCKWISE SPIN
REVERSE	STOP	REVERSE, RIGHT TURN
REVERSE	FORWARD	COUNTERCLOCKWISE, SPIN
REVERSE	REVERSE	REVERSE

When both motors are stopped, the machine stops; the machine runs forward when the motors run forward at the same speed; similarly, when both motors run in the reverse direction at the same speed, the machine runs backward. With the two motors doing different things, the machine is capable of a wide range of motion, For example, when one motor is running and the other one is stopped the machine follow the forward or reverse direction of the running motor.

An important feature of this arrangement is that there is no need to use separate logic and motion sensor. Furthermore the two motors can operate from identical circuitry; besides only one additional idle wheel is needed to balance the overall system.

2.4 External Response Mechanism

These types of devices attract the attention of the outside observer to the vehicle. Motion, sound and light are the three main external response mechanism. Motion is accomplished by way of a motor. Since the motion system requires some form of internal power,

batteries must be used. However batteries are sources of DC electrical energy, therefore DC motors are most often used for autonomous vehicle projects.

The sound systems available range from a simple wailing sound to synthesized human speech. This type of system is usually composed of a loud speaker and an audio amplifier.

In case light is the external mechanism of choice, LEDs will most likely be used. We must note that most IC devices cannot handle the necessary current to light a small LED, therefore a current driver circuit must be used in conjunction with these devices.

2.5 External Sensing Mechanism

External sensing mechanisms monitor the various conditions of the vehicle. In order to achieve intelligent motion, some form of external sensing is necessary. For example, it is essential for a vehicle to sense impending contact with an object. This is accomplished by way of ultrasonic sensing and optical sensing.

Most autonomous vehicle system necessitate some form of monitoring of the vehicle's position. This call for the use of potentiometers, optical and acoustical sensors.

2.6 Internal Response and Sensory Mechanism

Internal response and sensory mechanisms take care of the internal needs of the machine. In the absence of these mechanisms, the operator must closely monitor the internal environment of the machine in order to ensure its proper functioning of.

One of the most popular internal sensing mechanism is one that monitor the battery's voltage. This type of system is critical to autonomous vehicles since it prevents the system from shutting down when the battery runs low. A difference between internal response and sensory mechanisms and their external counterparts is that they operate in a totally electrical environment. In other word, they respond with an electrical signal while monitoring electrical parameters in the vehicles internal environment.

2.7 Internal Control Mechanisms

The internal control mechanism is of primary importance in the achievement of autonomous locomotion. One of the first decisions in the design of this mechanism is whether or not to use a microprocessor based system. In case human control is prominent, TTL, CMOS, MOS, Integrated Circuits as well as combinations of Linear and Digital Circuits can be used.

A more sophisticated vehicle require the use of a microprocessor. This device constrains the power supply option to a 5V supply or a +5V supply with low current and a +12V auxiliary power supply. The need for the auxiliary supply depends on the type microprocessor IC selected.

With a microprocessor, a bus oriented control system must be used. This narrows down the choice of subsystems to those that are compatible with the given microprocessor and bus configuration.

2.8 Power Supplies

The power supply should be selected after subsystems such as the motors, semiconductors and relays are chosen. The current rating of these devices dictate the ultimate voltage and current rating of the power supply. Since motors introduce electrical noise in the power source, it is good practice to use more than one internal power supply. One is usually dedicated to the motors and the other to the logic circuitry.

The voltage rating of the motor should match the voltage rating of it's power supply. In the event where more than one motor is used, it is advisable to use motors with the same voltage rating.

The ampere hour rating of the main power supply should enable the system to run for a considerable period of time at full power. The same consideration should be made for the logic and control circuit's battery. This power supply should have a voltage rating equal the IC's rating.

It is advisable to select a logic power supply with a larger ampere hour rating than the motor's battery. This way the machine is going to have some decision capability even when the motor's power supply runs out.

Finally provision should be made for a battery charging system, if the vehicle is expected to run indefinitely. However, one should avoid recharging the battery too quickly.

CHAPTER 3

ELECTRONIC HARDWARE

The electronic hardware constitutes a major part of any robotics system. It is made of circuits that controls the various actions of a robot including: power supplies, feedback signal processing and servo system controlling. These controls are mainly composed of digital type technology, in other words, electronic switching circuits functioning with discrete increments. They operate under two conditions: on and off. The level of current is normal at the on condition, however the system experience a sharp drop of current at the off condition which doesn't always mean a complete interruption of current flow. These two discrete conditions correspond to logic level 1 and logic level 0 in a binary system. This chapter is going to deal with the basic elements of electronic hardware that we are going to encounter throughout this project.

3.1 Circuit Elements

Semiconductors consists of crystals such as silicon that in certain circumstances carry electricity. They are neither full fleshed conductors nor insulators. Their conductivity lies half way between these two extremes.

3.1.1 Different Type of Semiconductors

There are two types of semiconductors: the p type and the n type. The p type semiconductors are deficient in electron. This deficiency stems from the introduction of impurities in the crystal structure. These impurities, known as acceptors, can accept electrons from a neighboring atom, creating a hole in the crystal's structure. Other electrons will try to fill the hole, creating another hole in a chain reaction that results in a flow of electricity through the semiconductor.

N type semiconductors have an excess of electrons. This is created by the introduction of a type of impurity known as donors. When two types of semiconductors are placed side by side as shown in figure 3.1, a current flow can be generated from the p side to the n side because of the tendency of the extra electrons from the n side to fill the holes created in the p-type semiconductor. The flow of current in the opposite direction is negligible.

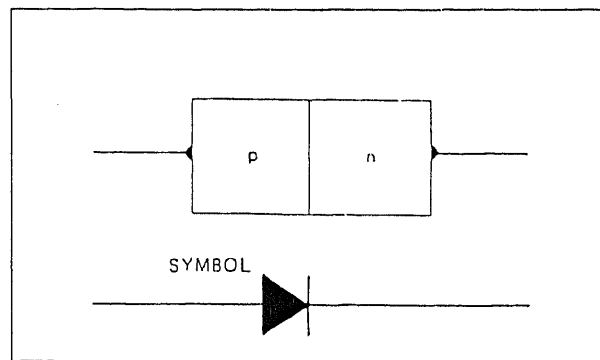

Figure 3.1 Rectifier Diode.[3]

Rectifier diodes are based on this type of technology. They allow current flow in one direction while minimizing the flow in the opposite direction. An increase in the reverse voltage will result in a slight increase in opposite current flow until the breakdown voltage is reached. At this point, the blocking action vanishes. The diode, therefore, has to operate under the breakdown voltage to be effective.

This breakdown action results in a high volume of electrons penetrating the barrier. There is a special type of diode that utilizes this avalanche type action, they are called avalanche type action, they are called avalanche or zener diode. The curve in figure A.2 in the appendix, illustrates the rectifier action and the avalanche action.

A zener diode used in series, across a load can protect against excessive voltage. By setting the breakdown voltage slightly below the excessive voltage, the diode will bypass the current and reduce the voltage before excess voltage can damage the circuit.

There is a variety of diode that deal with light, they are known as optoelectronic diodes. These devices are either triggered by light as in the case of photodiodes or emit light. In photodiodes light is guided to the area between the p and the n regions. This result in an increase in reverse leakage current. The conductivity of this type of diode is directly proportional to the intensity of the light.[3]

Light Emitting Diodes or LEDs also have a pn diode. However, in this case, as the electrons travel from one section to the other, they emit electromagnetic radiation which is transformed into light.

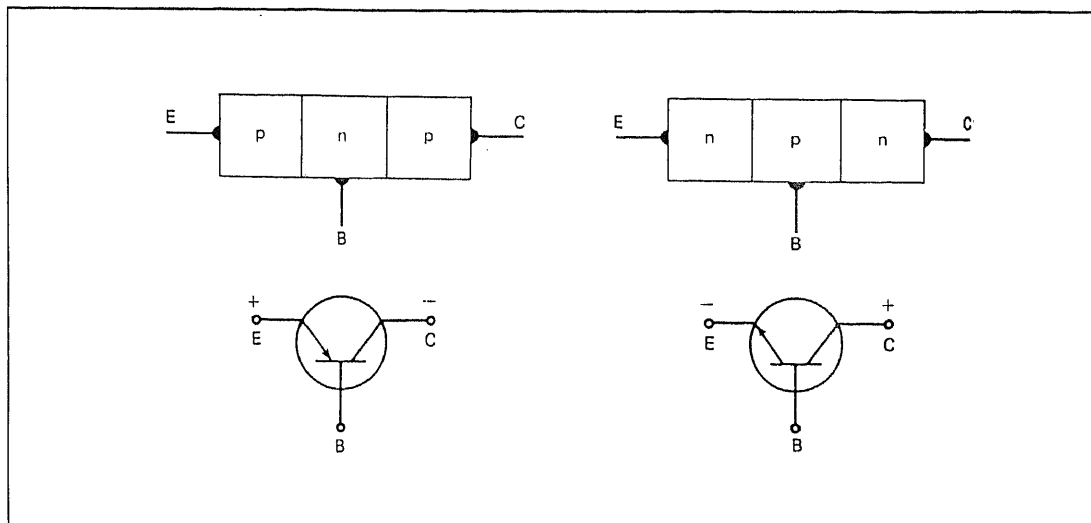

Figure 3.2 Bipolar Transistors.[3]

3.1.2 Transistors

When an n type or a p type of semiconductor is added to the pn structure, we end up with a bipolar transistor as shown in figure 3.2. The center area is known as the base and the outer regions are the emitter and the collector. In pnp transistors, the negative region is at the base, the emitter is at the positive side of the power source and the collector of the negative side. In this case the control current flows from the emitter to the base, it controls the transistor's action. The working current flows from the emitter to the collector. In the npn transistor, we have the positive region in the middle. The emitter is at the negative

side and the collector is at the positive side of the power source. The working current in this situation flows from the collector to the emitter, and the control current from the base to the emitter.

These two types of transistors each contain two pn junctions. The base of the structure is very thin, the amount of impurities is kept at a minimum in that region. Therefore, the number of holes in the positive base is also kept at a minimum. Figure 3.3 presents a circuit with an npn transistor.

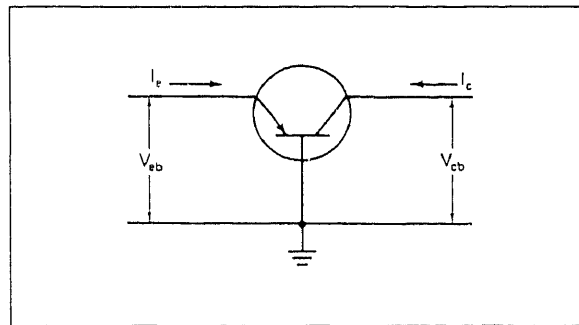

Figure 3.3 Circuit with an NPN Transistor.[3]

Because of the small number of holes in the base, most of the current flow from the emitter to the collector. We end up with a collector current that is much larger than the base current. The collector current I_c is the working current generated by the circuit, the base current activates the transistor. The purpose of a transistor can be summarized as boosting a small control into a much larger working current.

The operations of an npn transistor is very similar to the pnp transistor, the difference is that I_c becomes the control current.

3.2 Working With Gates

In order to interpret the actions of circuits, various methods have been developed that deals with binary switching systems. They are built on some simple concepts.

The simplest logic operations are AND and OR. The circuits that result from these operations are called gates. Other gates such as NAND, NOR, and Exclusive OR, are derived from these basic two gates.

The AND gate is composed of an output and several inputs. It can be compared to an electrical conductor equipped with several switches in series, the current will flow only when all the circuits are closed. Similarly an output will be generated from the gate only when all inputs have a binary level of 1, as indicated in the truth table in figure 3.4.





FUNCTION	SYMBOL	TRUTH TABLE															
AND		<table border="1"> <thead> <tr> <th>A</th> <th>B</th> <th>C</th> </tr> </thead> <tbody> <tr> <td>0</td> <td>0</td> <td>0</td> </tr> <tr> <td>0</td> <td>1</td> <td>0</td> </tr> <tr> <td>1</td> <td>0</td> <td>0</td> </tr> <tr> <td>1</td> <td>1</td> <td>1</td> </tr> </tbody> </table>	A	B	C	0	0	0	0	1	0	1	0	0	1	1	1
A	B	C															
0	0	0															
0	1	0															
1	0	0															
1	1	1															
OR		<table border="1"> <thead> <tr> <th>A</th> <th>B</th> <th>C</th> </tr> </thead> <tbody> <tr> <td>0</td> <td>0</td> <td>0</td> </tr> <tr> <td>0</td> <td>1</td> <td>1</td> </tr> <tr> <td>1</td> <td>0</td> <td>1</td> </tr> <tr> <td>1</td> <td>1</td> <td>1</td> </tr> </tbody> </table>	A	B	C	0	0	0	0	1	1	1	0	1	1	1	1
A	B	C															
0	0	0															
0	1	1															
1	0	1															
1	1	1															
NAND		<table border="1"> <thead> <tr> <th>A</th> <th>B</th> <th>C</th> </tr> </thead> <tbody> <tr> <td>0</td> <td>0</td> <td>1</td> </tr> <tr> <td>0</td> <td>1</td> <td>1</td> </tr> <tr> <td>1</td> <td>0</td> <td>1</td> </tr> <tr> <td>1</td> <td>1</td> <td>0</td> </tr> </tbody> </table>	A	B	C	0	0	1	0	1	1	1	0	1	1	1	0
A	B	C															
0	0	1															
0	1	1															
1	0	1															
1	1	0															
NOR		<table border="1"> <thead> <tr> <th>A</th> <th>B</th> <th>C</th> </tr> </thead> <tbody> <tr> <td>0</td> <td>0</td> <td>1</td> </tr> <tr> <td>0</td> <td>1</td> <td>0</td> </tr> <tr> <td>1</td> <td>0</td> <td>0</td> </tr> <tr> <td>1</td> <td>1</td> <td>0</td> </tr> </tbody> </table>	A	B	C	0	0	1	0	1	0	1	0	0	1	1	0
A	B	C															
0	0	1															
0	1	0															
1	0	0															
1	1	0															
EXCLUSIVE-OR		<table border="1"> <thead> <tr> <th>A</th> <th>B</th> <th>C</th> </tr> </thead> <tbody> <tr> <td>0</td> <td>0</td> <td>0</td> </tr> <tr> <td>0</td> <td>1</td> <td>1</td> </tr> <tr> <td>1</td> <td>0</td> <td>1</td> </tr> <tr> <td>1</td> <td>1</td> <td>0</td> </tr> </tbody> </table>	A	B	C	0	0	0	0	1	1	1	0	1	1	1	0
A	B	C															
0	0	0															
0	1	1															
1	0	1															
1	1	0															

Figure 3.4 Basic Gate Configurations.[3]

For the OR gate, as long as either of the inputs is on there will be no resulting output. The output will be level 1, even if both inputs are 1. The only way to get an output of 0 is to set both inputs at logic 0. This is equivalent to a circuit with two parallel switches.

The NAND gate is the opposite of the AND gate. The output is always at logic 1 except when the two inputs are set at logic 1. The NOR gate is similarly the reverse of the OR gate as the truth table illustrates. The exclusive OR gate is a variation of the OR gate, it is identical to the OR gate except in the situation where both inputs are 1, the output is then 0.

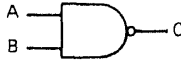
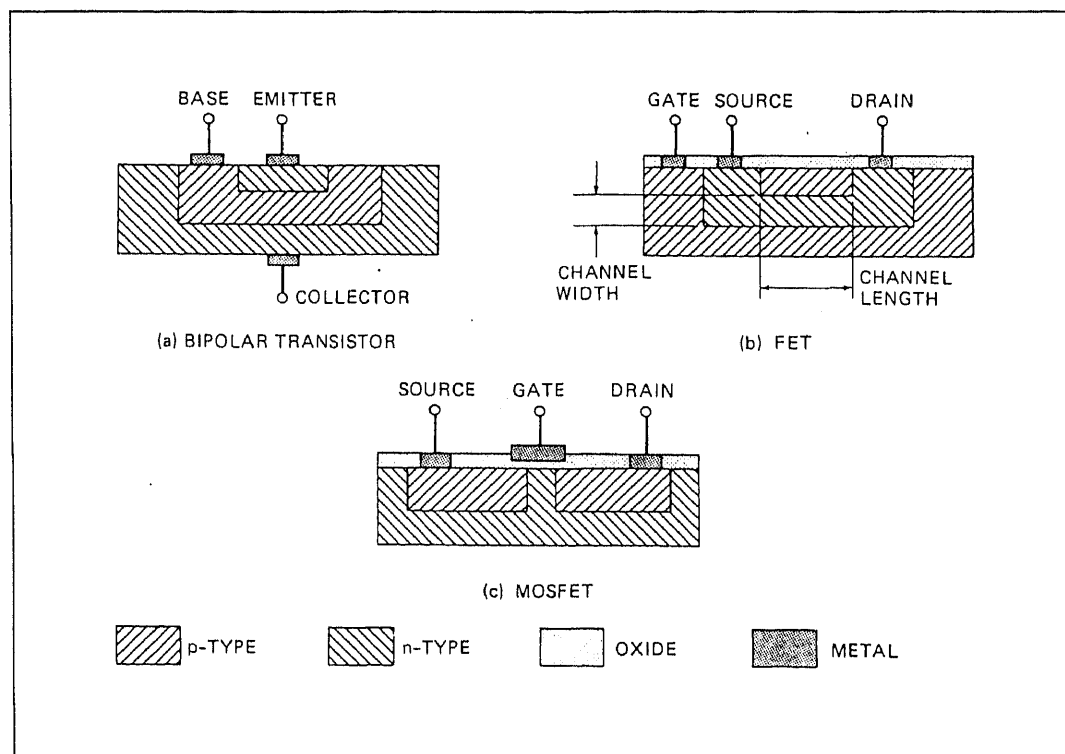

Figure 3.5 Structure of Bipolar Transistors, FETs and MOSFETs.

3.3 FETs And MOSFETs

MOSFETs stands for metal oxide field effect transistor, they were originally known as FETs or field effect transistor. Figure 3.4 illustrates the basic structure of FETs, MOSFETs and bipolar transistors. These types of transistors are made of silicon semiconductors "doped" with an excess of electrons in the case of n-type structures, or with an excess of holes as in the case of p-type structures. In a bipolar transistor the working current flows successively through p and n type material. However, in the case of FETs and MOSFETs, the working current either flows through n or p type material, they are both known as unipolar transistors. Unlike bipolar transistors, the three types of connections in FETs and MOSFETs are known as gate, source and drain. By applying a voltage at the gate, a current flow between the source and the drain can be controlled.[3]

N-channel FETs are controlled by a negative voltage applied at the gate, p-channel FETs are controlled by a positive voltage at the gate. A negative or positive input voltage can control the flow of current from the source to the drain.

The main difference between MOSFETs and FETs is that the material of the gate connection is not in direct contact with the semiconductor material, they are separated by a thin sheet of silicon oxide. Therefore, at the gate we find successive layers of metal, oxide, and silicon; hence the name MOSFET.

PMOS and NMOS are two types of MOSFET that differ in the way the current flow through the channel is produced. In the case of PMOSs holes are created in the semiconductor material, on the other hand in NMOSs the current is generated by an excess of electron between the source and the drain.[3]

CMOS devices use a combination of PMOS and NMOS devices. In this arrangement, only one of these devices is operating at any given time. CMOSs are used in memory systems, integrated circuits and various gate configurations.

CHAPTER 4

BATTERIES AND POWER SUPPLIES

In order to achieve autonomous locomotion an AGV system must incorporate a battery. This is part of an overall power supply system that also includes a suitable battery charger, an onboard power distribution system and an auxiliary power supply. The battery provides electrical power to the various components of the machine, including the motors, relays and electronic circuitry. The simplest power supply configuration contain one battery, which accommodate the voltage and current specification of the entire system. This type of system would be ideal if motors and ICs could coexist peacefully. However, this is not the case. Motors require a great deal of current when they start or stall. These power surges introduce a lot of noise in the system and can possibly destroy digital ICs. Isolating the ICs with voltage regulators won't guaranty a smooth running system. Therefore, a two battery configuration is preferable for most applications. One battery would be dedicated to the higher current devices such as the motors and the other to the electronic circuits.

A power distribution system is composed of fuses, voltage regulators, and electrical terminal blocks. Fuses protects the system in the event of a short circuit. Batteries can deliver an tremendous amount of current to short circuits, the primary role of the fuses is to isolate these incidents while shielding the rest of the AGVs internal environment. Voltage regulators as the name may indicate regulate the voltage supplied to digital circuits and precision linear devices. Not all components in an AGV system require the use of voltage regulators, motors and relays can be directly connected to the battery.

An auxiliary power supplies is an external source of power utilized during the testing phase. It temporarily replaces the battery in order to provide a reliable source of DC voltage before the system becomes fully operational. This type of supply can keep the

system operating indefinitely during calibration, while the declining power source of a battery can possibly hamper the testing procedure.

Battery chargers recharge the batteries when the voltage is running low. The charger selected for an autonomous vehicle system should match the requirements of the batteries. This is a very important specification, since recharging the batteries too quickly may destroy them.

The following section is going to provide a detailed analysis of the various components of a power supply system.

4.1 Different Type of Batteries

Selecting a battery can be tedious, there is a whole variety of them available on the market. The battery of choice depends on the designer's preference and the system's specifications. We are going to elaborate, next, on different kinds of batteries and their main characteristics.

Carbon-Zinc batteries are available in different voltage ranges, they are fairly inexpensive and have low current capacity. They also have moderate useful time and are not rechargeable.

Alkaline dry cells are quite similar to carbon zinc batteries, however they are more expensive and last longer.

Mercury cells are relatively expensive, the voltage rating selection available for these batteries is quite low. They have a fairly long useful life, a low current capability and are not rechargeable.

Nickel cadmium cells and batteries are fairly expensive, their range of voltage rating is rather narrow. Furthermore, they are rechargeable and their current rating is moderately high.

Lead acid batteries are inexpensive, they have a narrow range of voltage specification and are fully rechargeable. They also have long life and are available in high current ratings.

Gel-cell Batteries are quite expensive, they have a narrow range of voltage rating available and are fully rechargeable. Furthermore, their current ratings are moderately high and they have an extensive life.[2]

4.2 Battery Selection

There are several important criterias in selecting a battery for an autonomous vehicle project. The more important ones include: price, rechargeability, current handling capability and life expectancy.

Carbon zinc batteries are not rechargeable, therefore, they are not seriously considered for this type of project. The ability of an AGV to operate indefinitely would be seriously hampered, if this type of battery was selected.

Alkaline dry cell batteries have a longer life expectancy than carbon zinc batteries, however, they operate quite similarly. Besides, they are not rechargeable either and it would take a few of them in parallel to generate enough current for an autonomous vehicle project.

Mercury cells have the superior ability to steadily maintain their rated voltage, however, recharging them may provoke an explosion. Therefore, It is not suitable for an AGV.

Nickel cadmium cells and batteries constitute a serious improvement on the batteries considered previously. They require no maintenance and can be recharged as often as necessary. However they have low current capabilities and are relatively expensive. Since they have the ability to maintain there rated until they are ready to be recharged, they may be considered for low current electronic circuits in case a two battery system is being used.

Gel-cell batteries have a lot of potential for the future, however, their expensive price makes them unattractive to most designers. Because of their low current capacity, a number of them have to be used in series in order to provide enough current to the system.

Lead acid batteries are the most popular battery used in autonomous vehicle projects. They have a high current capacity and are relatively inexpensive. These batteries can be occasionally recharged with excessive current with no damage.[2]

4.3 Lead Acid Batteries Design Specifications

Lead acid batteries are categorized according to two ratings, the full charge output voltage and the current delivering capacity. The voltage rating is dependent on the voltage rating of the motor and electronic circuitry. A battery deliver its rated voltage when it is fully charged, it is considered discharged when its output is less than 80 percent of its full charge rating. For example a 6 volt battery is dead when it shows 4.8 V when fully loaded.

The Ampere-Hour rating specifies the current delivering capacity of a battery. It is expressed as the product of an amount of current by the time it takes the battery to deliver that current before being discharged. A 12V battery with an ampere-hour rating of 10 can deliver 10 amperes for one hour or 5 amperes for two hours. The Ampere-Hour rating of batteries is usually determined by discharging the battery for a standard ten hour period. This is indicated as the ten hour discharge rate.

4.3.1 Estimating the Average Current Demand

There are two main components that draw current in an AGV system, the motors and the electronic circuits. The total current consumed by the system is the sum of the average motor current and the current used by the electronic circuits

In order to find the average motor current, we must first determine the stall and start current of the motor. This information can be obtained from the designer's catalog or by measuring the current directly while stalling the motor. We then determine the amount

of current consumed by the motor while running. In case two motors are being used the respective values for the two motors are added together in order to find the maximum current value.

Under normal operating conditions the motor will draw stall current ten percent of the time, we need to account for that in determining the total current. The remaining ninety percent of the time, the motors are either turned off or running at their normal load. With equation 4.1 we can estimate the average motor current demand.

$$I_m = 0.1 * I_p + 0.9 * I_r \quad \text{Equation 4.1}$$

Where I_m =average motor current, I_p =The sum of the stall current of the motors, I_r = The sum of the running current of the motors.

In case the circuits are already installed, we can easily measure their current consumption by using an ammeter. In the event where the circuits are not yet constructed, there are no simple way of figuring out the current, we have to come up with an estimate. The simplest electronic circuit for a mobile robot will consume more than one ampere The more complex the system gets the larger that estimate will become. The larger systems can draw up to 8A. Another alternative in estimating the current demand is to assign one ampere of current to every 15 IC devices.[2]

With the inaccuracies of the previous methods of measuring the current demand, it may be wise to built the circuit first.

Equation 4.2 calculate the average current consumed in a one battery system.

$$I_d = I_m + I_s \quad \text{Equation 4.2}$$

where I_d = the average current demand of a single battery system, I_m =the average current required for the motors. and I_s = the estimated current required for the electronic circuit.

In case different batteries are used for the motors and the electronic circuitry, I_m becomes the total current demand for the battery that operates the motors and I_s becomes the total current demand for the circuit's battery.

In addition to the average current drain on the system, we also need to determine the amount of time the battery is expected to supply that current level before being discharged. This is known as the minimum ampere hour rating, (H_d). Using Equation 4.3 we calculate the minimum ampere hour rating by multiplying the total current demand on the system by the maximum running time.

$$H_d = I_d * T_d \quad \text{Equation 4.3}$$

Where H_d = the minimum ampere-hour rating, I_d = the total average current drain on the system, T_d = maximum desired running time.

Selecting an extended continuous running time can for the system can lead to trouble. We would have to choose a big battery that would introduce a lot of weight in the system. This would call for the use of bigger motors that would require more current. And finally more current results in using an even larger batteries. The running time should be kept around two hours, this is a compromise that will lead to a better design.

After calculating the ampere-hour rating and determining the voltage figure we can simply use a battery catalog to select batteries for our system.

4.4 Selecting Battery Charger Systems

A battery must be charged properly in order to reach its maximum useful time. This is most often a matter of recharging the battery at the rate prescribed by the manufacturer.

Certain battery charts list the nominal recharge rate as a current level. In that situation, there is no need to figure out the recharge current. In most cases, however, we have to calculate this figure. It is good practice to avoid charging a lead acid battery at a rate higher than the 10 hour discharge rate. Some batteries are rated according to their ten hour discharge rate. This figure also constitute the maximum recharge current rate. The ampere hour rating is most often used to categorize the batteries. In that particular situation we just need to remember that the ampere hour rating is based on a ten hour

discharge rate, therefore, we just need to divide it by 10 to obtain the maximum continuous recharge current.

4.4.1 Battery Recharge Characteristics

Figure 4.1 illustrates the charge curve for a battery and battery charger system. Initially we can observe a current surge. This peak condition depends on the characteristics of the battery charger and the condition of the battery. the current surge can be four to five time greater the nominal charge current. After about 10 seconds it settles down to the rated charge current.

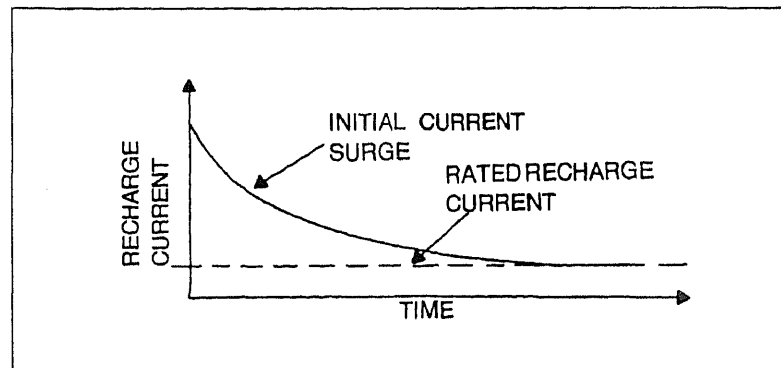

Figure 4.1 Charging Curve for a One Battery System.[2]

A good battery tend to control its own recharge rate, on the other hand an old battery draw the initial current surge for a longer period of time.

In general there will always be current flowing from the battery charger to the battery. This is due to the fact that the output voltage from the charger is always slightly higher than the voltage rating of the battery. Therefore we cannot count on a battery showing zero recharge current in order to end the recharge cycle. Instead we should expect a current charge one half to three quarter the nominal recharge rate. For example a battery with a nominal recharge rate of 5 amperes can be considered fully recharged when drawing 2.5 to 3.75 amperes from a charger.

The ratio of the running time to the sum of the running time and the recharging time of a battery, known as the operating duty cycle, is a good indication of how long it takes to recharge a battery. In the ideal situation we would have a large operation duty cycle with a long running time and a short recharge time, however, this is not possible. The time spent recharging the battery is longer than the running time of the machine.; as a matter of fact, it takes 5 to 10 times longer to recharge a battery. This is obviously an inconvenience, however, the only feasible way around it is to use more than one set of batteries, with a set always at the charger.

Battery chargers are categorized by the voltage rating of the batteries they can recharge; and a maximum charge current which correspond to the initial current surge that these batteries can withstand.

The following guidelines are helpful in designing a battery charger system:

- The battery charger's voltage should match the voltage rating of the battery selected.
- The battery charger should have a current rating that is 4 to 5 times the batteries' recharge current rate.
- Making sure the charger is equipped with an ammeter and a voltmeter.[2]

4.4.2 Charging More than One Battery

The previous section concentrated on the charging of a battery while it is disconnected from the vehicle. In reality it is often necessary for the battery to provide power to the electronic circuitry while being recharged. Furthermore, it is sometimes required to charge more than one battery at a time. Certain system have some memory capability; in case the battery is disconnected for a few seconds, the memory circuitry may loose their content. This sort of circuit need supply voltage while the system is being charged, this source of voltage is usually the battery being recharged.

Under normal circumstances, the motor and electronic rely on the battery as a source of power. At the instant where the battery charger is connected, the supplied voltage is directed toward charging battery, and toward the motors and the electronic circuitry. The motors should be turned off during the charging cycle. The charger may not be able to provide the necessary current for starting them anyway; besides, the machine is suppose to stay stationary until the end of the cycle.

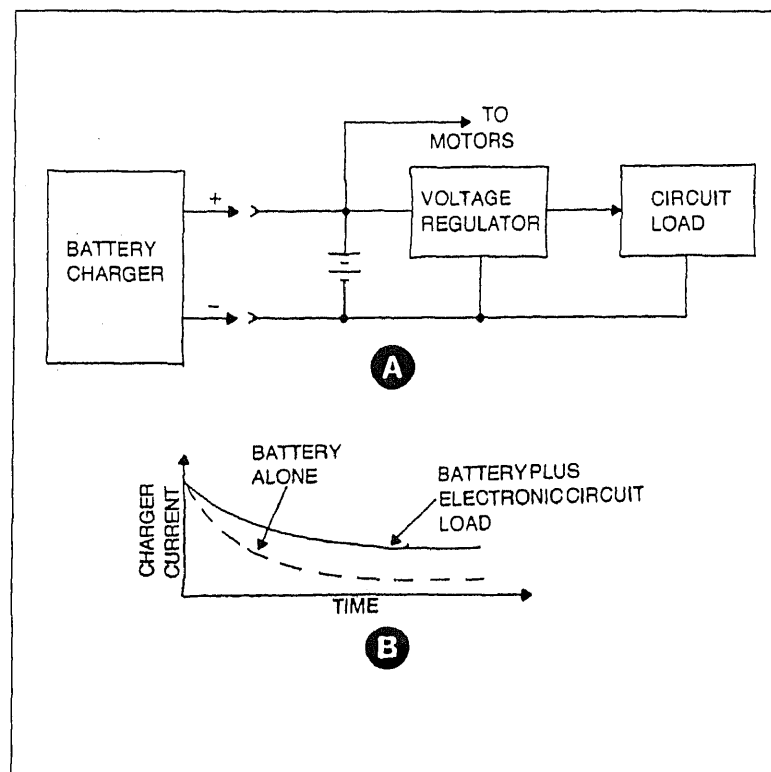

Figure 4.2 Power On Recharging. A) Block Diagram
B) Charge Curve.[2]

Figure 4.2B illustrates how this charging scheme distorts the usual charging curve of the battery. The dashed line curve represents the charging of one disconnected battery, while the solid line indicate the power on charging scheme. We can notice that the initial surge in current is the same. This initial condition is controlled by the current capacity of the charger itself, therefore it is the same regardless of the current demand on the system.

In case the charger's output voltage is greater than the voltage of the battery being charged, the electronic circuitry will be the beneficiary of a sizable portion of the charger's current, regardless of the battery's status. However, if the battery charger is electronically regulated, the amount of current directed toward the circuits decreases as we go further in the charging cycle, allowing the battery to provide more and more of the circuit's current.

The power on charging scheme has to be taken into consideration when selecting a battery. In order to charge the battery in the shortest amount of time, the charger's current ought to be five times the sum of the nominal recharge rate added to the current necessary to maintain the electronic circuitry. This results in selecting a large and expensive charger. A trade off in this case is to ignore the circuit's current, and select a smaller battery which results in a slightly longer charging cycle.

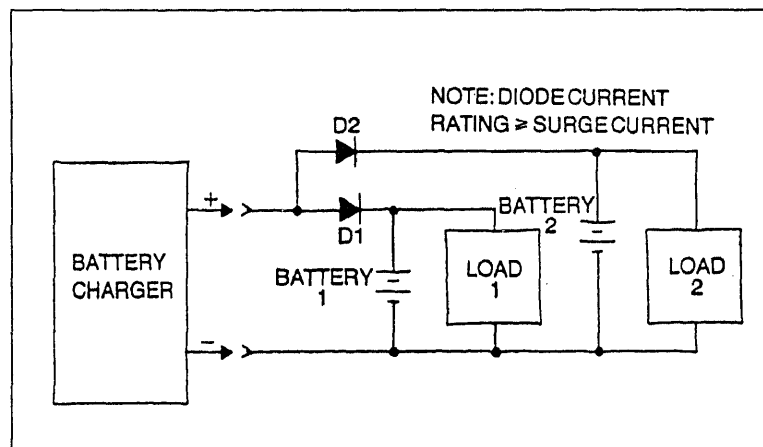

Figure 4.3 Recharging More than One Battery. [2]

If we are dealing with identical batteries, charging more than one battery won't be a difficult task. As illustrated in figure 4.3 the batteries need to be isolated from each other by way of rectifier diodes. During the charging operation, the diodes prevent any exchange of current between the battery with the higher charge and the other battery. On the other hand the charger's are forward biased when it comes to power from the charger. In the situation where the two batteries have the same ampere-hour and voltage rating, they will

control their own recharge rates. The one with the greater current demand will draw more current from the charger. There is a possibility of overcharging the battery with the lower charge. It is generally safer in this case to use a battery charger capable of charging one battery at a time. The charging cycle will last longer, however, the only other alternative is to use separate battery chargers. This last option may not be economically feasible. The degree of difficulty in charging the batteries is much higher when two different type of batteries are used. It is safer in this situation to use two different battery chargers in order to accommodate the two batteries.

4.5 Power Distribution Systems

A power distribution system that handles more than two amperes must adhere to several rules in order to ensure a good design. First of all the wires must have an adequate current rating: Using the same wire throughout the system without considering the requirements for different parts of that system will lead to disaster. Second, solder joints should be avoided since, they are difficult to modify; and these connections tend to break down when exposed to high current surges. Finally, the power distribution wiring should be kept as short as possible. Long wires can round off the high current spikes necessary for starting the larger components of the distribution system. Table 4.1 contains the recommended wire sizes for peak current between 3 A and 25A. For example it shows that an 18 gage wire can sustain current surges of up to 3A.

Table 4.1 Wire Size as a Function of Peak Current.[2]

Peak Current Rating (Amperes)	Minimum Wire Size(AWG)
3	18
6	16
15	14
20	12
25	10

A common mistake among power distribution system designers is failing to use adequate return wiring for high current circuits. The common ground connections represents the negative polarity of the power supply. While experimenters may be conscious that positive wiring to the motors requires larger gage wiring, they sometimes forget that the return wiring to the negative terminal requires wire of the same gage.

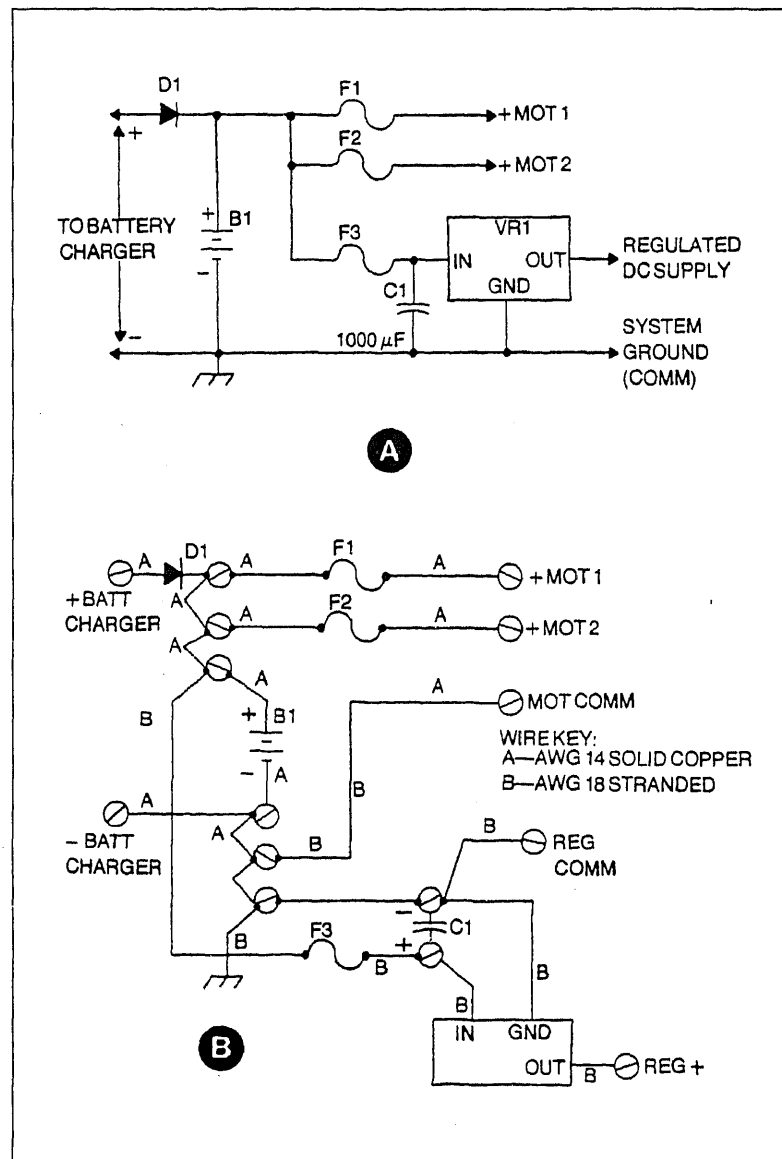

Figure 4.4 A Power Distribution Scheme A) Schematic Diagram
B) Wiring Diagram.[2]

Figure 4.4A represents the schematic diagram of a simple power distribution system. We can notice that a heavier gage wire is used for the two motors as compared to the voltage regulator. Figure 4.4B illustrates the wiring diagram for the same circuit. We can notice that the circuit is wired with two different wire sizes. The sections of wire carrying the heavier load is labeled A and is composed of 14 gage wire capable of handling up to 15A. The sections of wire labeled B is composed of 18 gage hook up wire which can handle up to 3A. All wiring sections carrying the motor load including the return wiring are made of 14 gage wire.

In summary, the current specification dictates the wire size, the wire size subsequently dictates the size of the solderless terminal. The solderless terminal size dictates the specifications for the barrier strip or terminal block.[2]

4.5.1 Fuse Protection

The two main reasons for using fuses in an electrical system are: first, to protect the wiring and second, to protect the electrical devices and the circuits. The important thing is to protect the wiring to the boards and prevent a short circuit condition from causing fire in the system.

It is advantageous that the voltage regulators are current limiting. In other words, they turn themselves off in case of a short circuit. The boards are, therefore, protected from short circuit damage since they are all equipped with a regulator. The wiring to the boards, however, still need to be fused for protection in case of a short circuit in the power distribution system. The motors, for example, have to be fused individually.

Since they protect the power distribution system, fuses should be located as close to the power source as possible. Table 4.2 summarizes the blowing characteristics of some commonly used fuses. They are categorized as fast acting or slow blowing and according to the current rating. The current ratings are not listed in the table, they can be found in

electronic catalogs. Table 4.2 also lists the length of time during which the fuse is expected to carry a given percentage of its rated current before it blows.

Table 4.2 Blowing Characteristic of Small Glass Fuses.[2]

Type	Percent of Rated Current	Approximate Blowing Time
Fast Acting	100-110	Will not blow
	135	1 hour maximum
	200	5 seconds maximum
Slow Blow	110	Will not blow
	135	1 hour maximum
	200	25 seconds maximum
	300	8 seconds maximum
	500	3 seconds maximum

Fast acting fuses are oversensitive to current overload. According to table 4.2, a fast acting fuse will carry twice their rated current for 5 seconds before clearing. In case the current is more than 200 percent of its rated current, it will take less time to blow.

Slow blow fuses are less sensitive, they will carry twice their rated current for up to 25 seconds before blowing. Slow blow fuses are preferable for devices such as DC motors that routinely draw surges during start and stall.

4.5.2 Auxiliary Power Supplies

One of the main reasons to include an auxiliary power supply in the system is to have a steady source of DC supply for troubleshooting and testing the electronic circuitry. This is vital in the lengthy process of calibrating of the various electronic circuits of the machine.

The auxiliary power supply is usually built into a separate housing. When the system is operational, it can be built into the machine or set aside at a convenient place. If

the first option is adopted, emergency power can be provided to the system by plugging the auxiliary supply to a 120 VAC outlet.

CHAPTER 5

SENSORS FOR AUTONOMOUS VEHICLE SYSTEMS

"Nothing reaches the intellect before making its appearance in the senses". This famous Latin proverb undoubtedly, is reflective of the importance of the senses in our daily activities. An autonomous vehicle also relies heavily on its sensors. There are two types of sensors in a mobile robot system: internal, and external.

In their own way these two categories of sensors are major contributors in the operation of the vehicle's internal environment and its interaction with the external environment. In this chapter we are going to analyze different types of sensors that are used in automated guided vehicles.

5.1 Motor Speed Sensing Mechanisms

There are two different types of mechanism for motor speed sensing. One uses optical technology, and the other is electromechanical. The choice of internal sensor depends on the nature of the system and the designer's preference.

5.1.1 Optical Motor Speed Sensing

Figure 5.1 illustrates the general arrangement of an optical sensor. It is composed of a disc with perforated holes on the outer edges mounted on the motor's shaft. An LED is fixed on one side of the disc and a phototransistor on the other side. This system is arranged so that the light from the LED will hit the encoder phototransistor's lens, whenever a hole is positioned between them. As the shaft turns, the phototransistor switches on and off at a rate proportional to the motor's speed. It is the frequency of the phototransistor's rectangular wave form that indicate the speed of the motor.

$$f = M_r(n)/60 \quad \text{Equation 5.1}$$

Where f = the frequency of the wave form from the phototransistor, M_r = the motor speed in rpm, n = the number of holes around the perimeter of the disc.

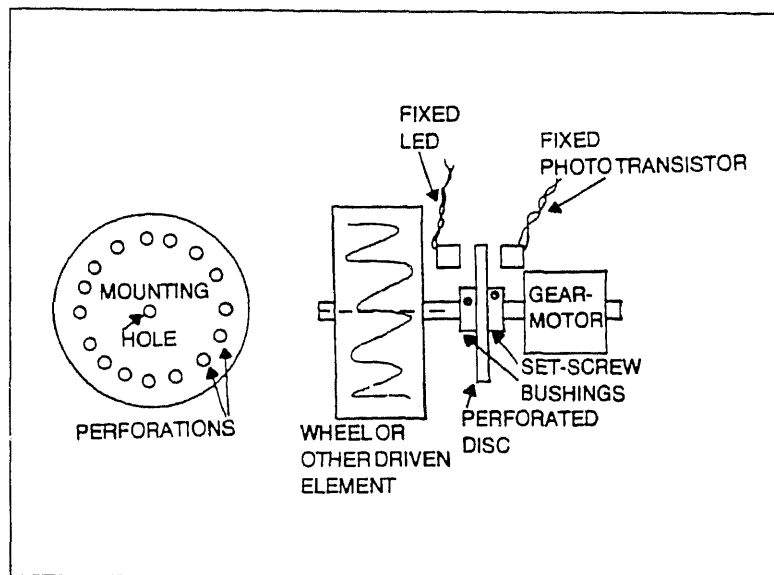

Figure 5.1 Optical Sensor Arrangement.[2]

The system becomes more and more precise with increasing number of holes. In order to design an optical speed sensor we must first decide the slowest speed we want to sense and the maximum time delay for sensing that speed. For example, if we use a working speed of 30 rpm and a maximum allowable delay of 0.1 seconds. The minimum working frequency from the phototransistor is $1/0.1 = 10$ hertz. By plugging these numbers into equation 5.1, we can solve for the number of holes.

$$n = (60 \cdot 10 \text{ hz}) / 30 \text{ rpm} = 20 \text{ holes}$$

The following equations take us through the hole design process for an optical encoder.

$$n = 60f_m / M_r \quad \text{Equation 5.2}$$

$$n = 60 / (M_r \cdot t_m) \quad \text{Equation 5.3}$$

Where n = the minimum number of holes, f_m = the lowest desirable sensing frequency, t_m = the longest desirable time delay for sensing, M_r = motor speed in rpm

$$a = 360/n \quad \text{Equation 5.4}$$

Where a = the angle between the holes in degrees and n = the number of holes.

$$r_{1m} = (n*d)/\pi \quad \text{Equation 5.5}$$

Where r_{1m} = The minimum radius of hole placement, d = the diameter of the perforated holes.

$$d_2 = 2*r_1+d \quad \text{Equation 5.6}$$

Where d_2 = the overall diameter of the holes, r_1 = radius of the hole placements.

With equation 5.2, we can calculate the number of holes necessary for generating a minimum motor speed output frequency. Equation 5.3 calculates the minimum number of holes. In case this number is not a hole number, we have to compromise to the next higher integer value. Equation 5.4 help us determine the number of degrees between the perforated holes on the encoder. With equation 5.5, we can keep the disc as small as possible, it gives the minimum distance between the center of the disc and the center of the perforated holes. The d term represents the diameter of most LED transistors 3/16 of an inch. Finally Equation 5.6 provides the diameter of the entire disc assembly.

After designing the disc, we can mount it on the motor's shaft. While this is an ideal position with the disc and the shaft rotating at the same speed, it is sometimes not possible to assemble the encoder at that preferred position. An alternative solution is to pick up the motor speed at a point ahead of the speed reducing gear. In this case, we have to work with the higher rpm figure.

Figure 5.2 presents a simple circuit for this for an optical encoder. The phototransistor's conduction PT300, changes with the amount of light reaching through the disc's perforated holes. The phototransistor switches off when a space between the perforations interrupt the flow of light. In the ideal situation, the voltage wave form at the collector switches between the logic supply voltage and zero. However it is almost never the case. Ambient lighting and stray reflection from the LED introduces a lot of noise in the optical system. this calls for the use of signal conditioning. In figure 5.2, a sensitivity

adjust control R302 and a voltage amplifier Z300 takes care of this task. The circuit is first desensitized by putting the majority of the undesirable lighting at a level below that of the sensitivity adjust control. The stronger light signal from the LED rises above the noise level and the amplifier bring this signal back to a desirable voltage level.[2]

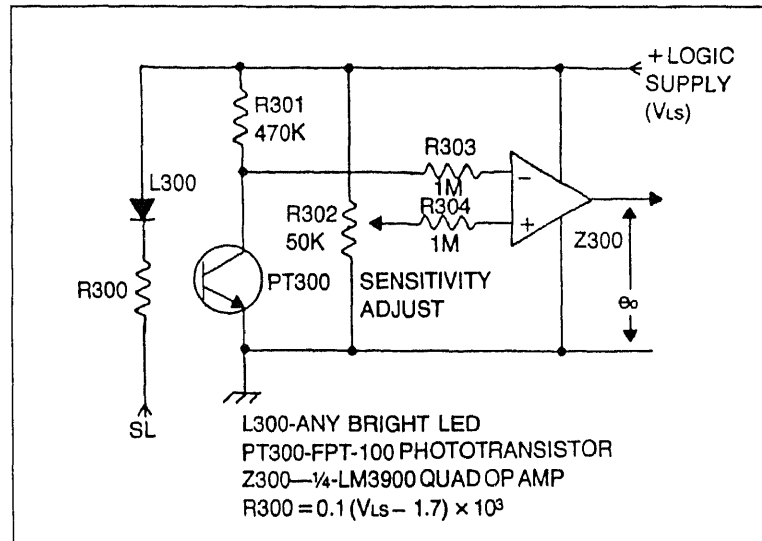

Figure 5.2 Circuit for Operating an Optical Motor Speed Sensing System.[2]

5.1.2 Electromechanical Speed Sensing

Electromechanical speed sensing operate on the principle that a permanent motor can function either as a motor or a generator. Whenever DC voltage is applied to its commutator ring and permanent coil, it operates as a motor. On the other hand, when the shaft is externally driven, AC voltage is created at the commutator ring. This voltage is proportional to the rpm of the motor.

5.2 Sensing Current and Voltages

5.2.1 Voltage Sensing

Voltage sensors are simple voltage amplifier circuits with an input impedance much greater than that of the device it monitors. This is a very important specification, the sensor would otherwise become a significant part of the load and the original characteristic of the voltage source it is suppose to measure would change as a result of this.

5.2.2 Current Sensing

While voltage sensing is relatively an easy operation, it is much more difficult to sense a current level. Because of this, the majority of current sensors convert the current into a voltage level, simplifying the task at hand.

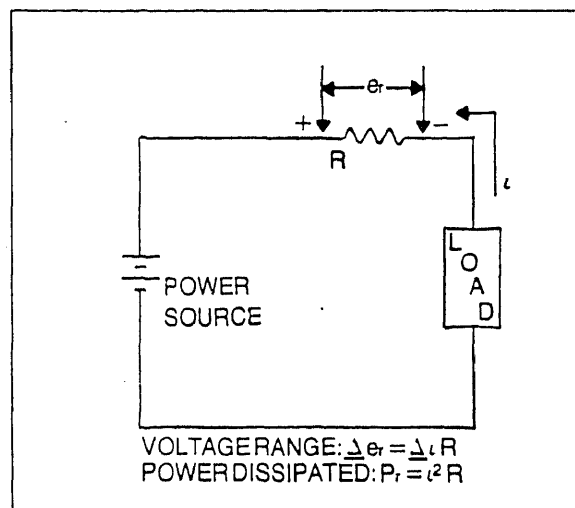

Figure 5.3 A Circuit for Translating a Current Level into a Proportional Voltage Level.[2]

There are two major methods of sensing current levels. In the first one, a resistance is inserted in series in the circuit, it converts the current level to a voltage drop. Figure 5.3 illustrates a circuit for translating a current into a proportional voltage level.

This process seems straight forward, however some complications may arise. For example, the resistor may take voltage away from the load. In case we are dealing with a DC motor, the voltage will be taken during start when the motor consumes its highest level of current. Another problem is that the resistor may consume more power than anticipated. Equation 5.1 will help determine the appropriate resistor value.

$$R = \Delta e_r / \Delta i \quad \text{Equation 5.1}$$

Where R = Sensing resistor value, Δe_r = the difference between the maximum and minimum voltage drop, Δi = the difference between the maximum and the minimum current to be measured.

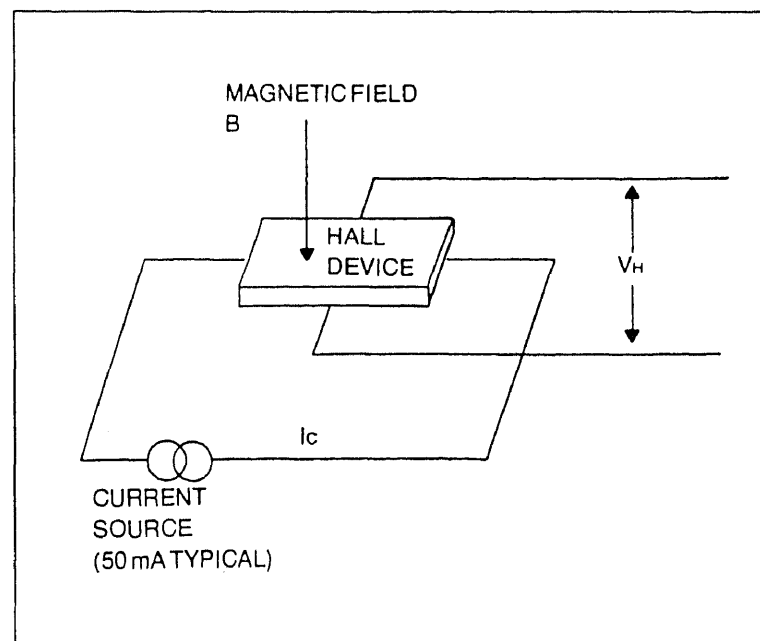

Figure 5.4 A Hall-Effect Current-Sensing System.[2]

Figure 5.4 presents the other current sensing method. This approach consists of sensing the magnetic field generated by a current flow through a conductor and changing it into a voltage level using a Hall Effect-type device. The problem associated with series resistor sensors are nonexistent in Hall Effect devices, however, they are fairly expensive.

A Hall Effect device is composed of a piece of semiconductor material with no pn junction. As we can observe from figure 5.4, this system is composed of a control current I_c , that flows from one end of the device to the other. There is a magnetic field B on the outside of the device, perpendicular to the direction of the current flow. When a current-carrying conductor is placed parallel to the device's control current I_c , a voltage will be developed which is proportional to the varying strength of the magnetic field.

5.3 Vision Sensors

The second and third generation robots were the first to have the ability to process and respond to environmental data. They required sensors capable of processing the environmental feedback necessary to increase the flexibility of the robots. The external type sensor chosen depends on the application at hand. In the field of mobile robotics, vision sensors have proven to be the most powerful and flexible type of environmental feedback devices.

The name vision sensor originated from similarities between these type of sensors and the human eye. This is more evident in the case of vacuum and solid state cameras. In the case of three dimensional vision sensors such as rangefinders, mechanical scanning is used to acquire data. Figure A.4 in the appendix presents a generalized block diagram of a vision sensor system.[5]

5.3.1 Two Dimensional Sensors

Two dimensional sensors rely on optical array transducers such as CCDs, DRAMs, photodiode arrays and specially arranged lighting. Some two dimensional sensors have limited processing capability which allow them to interact with the illumination system and assume some of the data processing task. There are two major types of vision sensors: binary and grey level.

With binary sensors, the image produced consist of pixels that are either black or white corresponding to an equivalent logic of 0 or 1. The picture generated is therefore a series of logic level 1 or 0. The low visual data content of this type of image results in rapid processing of the visual data acquired.

Grey level vision sensors produce an image with pixel values divided into discrete levels. This is accomplished by converting the analog output of transducers into digital signals. When a DRAM camera is used, a grey level image is produced by processing a number of binary images using different exposure time. This result into different pixel intensity. Grey level vision sensors produce images with more details of the object surface feature. However, this results in increasing visual data and more complex processing.

5.3.2 Stereo Vision

There are two major stereo vision methods. The disparity technique uses images of an object from two cameras under the same lighting condition. The photometric technique processes images from the same camera under different lighting conditions.

Stereo vision sensors are also composed of optical array transducers such as CCDs, DRAMs, and photodiode arrays. They generate different images of an object taken from different positions.

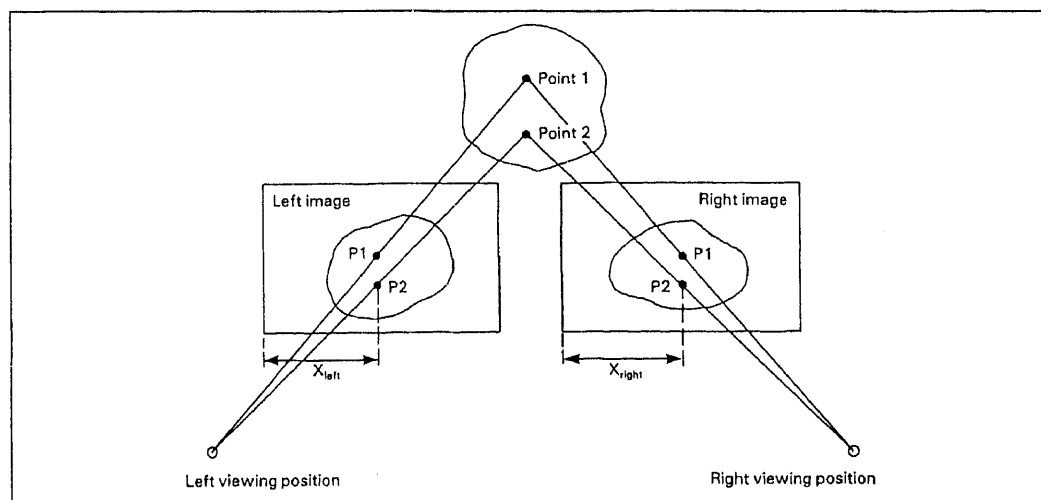

Figure 5.5 Stereo Imaging Diagram. [5]

Figure 5.5 illustrates the stereo imaging diagram of an object. As we can observe points P1 and P2 on the left and right images represents the same points on the object's surface. Therefore, the points on the object, must lie on the line joining the point on the focal lens and the image points. Since points 1 and 2 of the object are visible from both views, they lie at the intersection points of the line from the two images. The distance from the imaging device can then be calculated by triangulation.

This calculation is performed by a computer in three step:

- 1) Locating a pair of points from the object is on the left and right images, which correspond to the same points P1 and P2 on the object. This is not an easy task since identifying the same features on different images is difficult to accomplish.
- 2) Determining the two dimensional coordinates of the points on the left and right images in order to find the difference between the x and y positions from these two images.
- 3) Calculating the distance from the object to the imagine device by triangulation.

There are three methods for obtaining the different views required for stereo vision:

- a) The first disparity method consists of two stationary cameras and an illuminating system.
- b) The second disparity method uses one camera moved to different known positions, and an illuminating system.
- c) The photometry method uses one stationary camera in different lighting conditions.[5]

5.3.3 Optic Flow

Optic flow utilizes the information acquired by vision sensors to provide visual information from the motion of a vehicle.

As a vehicle translate through world coordinates, the points from successive image plane of the scene form vectors that can be used to describe the direction and velocity of these points. Each of these vectors represent the distance from the observing device to a point from the scene. When we consider a group of point from the same surface, their distance indicate the orientation of the surface with respect to the observing device.

The calculation of the optic flow vectors involve matching points from subsequent images of the same features, this is known as a correspondence problem. This can be solved by using one of two methods: feature matching, and temporal gradient analysis. Feature matching involves the isolation of points and regions that can be easily recognized. These various features from each frame of the sequence of pictures are then matched. In the temporal gradient method, variations in brightness at different regions of the pictures are processed in order to estimate the direction of motion of the surfaces that incorporate these regions. After the approximation of the flow vectors from the images, the orientation of the surfaces are then determined and the machine can initiate corrective motion.

We must note that problem of inaccuracy have restrained optic flow as a navigational technique for autonomous vehicles. Optic flow require the analysis of a large number of images. This is a time consuming process that further limits optic flow as a method of navigation.[6]

5.4 Range Measuring Sensors

In terms of speed of operation and data processing, Direct range measuring sensors have some definite advantages over vision systems.

5.4.1 Scanning Optical Range Finders

The scanning optical rangefinder technique consists of the mechanical scanning of a target object with a laser beam. The reflected laser light after being processed, provides information about the range, resulting in a depth map. A drawback from using this type of

three dimensional sensor is their relative high price. Figure A.4 in the appendix presents a generalized diagram of a scanning laser range finder.

5.4.2 Static Range Finders

The operation of static LED range finders is similar to scanning range finders. An LED is focused on an object and the processed data from the reflected light provide range data. Mechanical scanning is avoided by "multiplexing" the drive to the LED matrix so that one LED is on at any given moment. This is achieved by using one of the following two major techniques: an x-y LED array or a circular LED array sensor.[5]

5.4.3 Ultrasonic RangeFinders

An ultrasonic rangefinder's operation consist of measuring the time delay between the transmission of a sound pulse and its reflection assuming a constant velocity for sound propagation. The distance between the range finder and the targeted object can be calculated using the following equation.

$$d = v*t \qquad \text{Equation 5.2}$$

Where d= distance between the range finder and the object being scanned, v= velocity for sound propagation, t= time delay between transmission and reflection of sound pulses.

For the purpose of collision prevention for an autonomous vehicle, an ultrasonic rangefinder arranged at a strategic position on the front of the vehicle can activate a microswitch to stop the machine in order to avoid an obstacle. This could also trigger a series of maneuvers to avoid any collision.

Figure 5.6 presents the major steps involved in the ultrasonic distance measuring process.

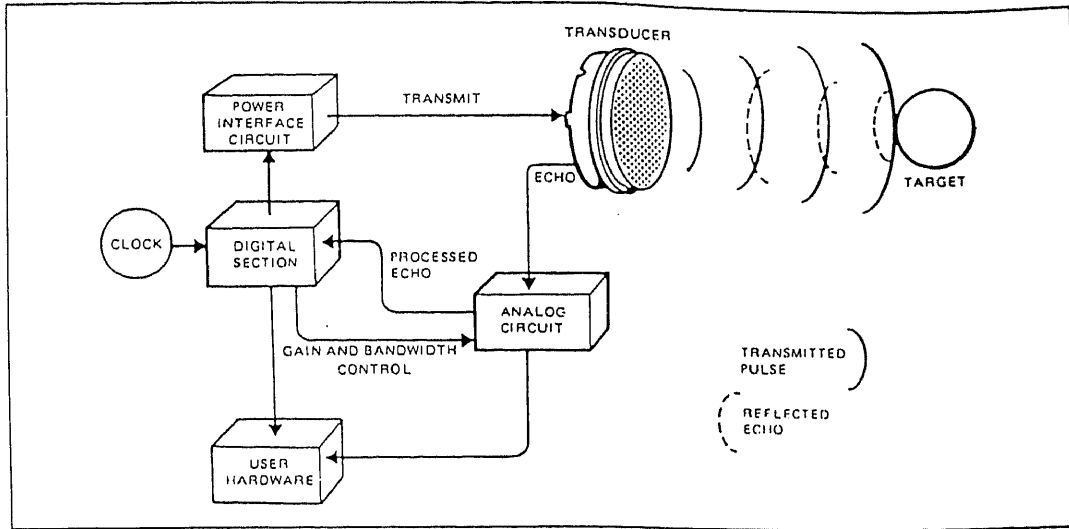

Figure 5.6 Ultrasonic Sensor Functional Block Diagram.[5]

CHAPTER 6

DC MOTORS

Selecting the appropriate set of motors is one of the most important steps in designing an AGV. The size of a motor depends on the amount of mechanical load that is going to be applied to it. It is essential to choose the right motor size, one that is capable to drive the vehicle without introducing too much weight to the system

Another important part of the selection process for a motor is the speed requirement. Most of the motors used for AGV projects are geared down to achieve the desired speed. The speed requirement usually entails choosing a gear motor or a motor gear train arrangement. A gear motor is a type of motor that include a set of speed reducing gears as part of its assembly.

This chapter incorporates various parameters and specifications that are essential in selecting and working with DC motors for an autonomous vehicle system.

6.1 Motor Specifications

6.1.1 Operating Characteristics of a motor

DC motors react against a current flow created by an applied voltage, in other words it consumes electrical power. A good portion of that power is transformed into mechanical work, however some of it is dissipated into heat energy. The efficiency of a motor is the ratio of the mechanical power to the total power consumed from the power source.

There is a certain amount of winding resistance in a DC motor. This resistance range from 0.5 to 100 ohms, depending on the motor specifications. The maximum amount of current a motor can draw from a power source is equal to the applied voltage divided by the winding resistance.

While running, A motor generates its own voltage that tend to counter the applied voltage. Since the motor current is directly proportional to the applied voltage, the resulting running motor current is thus less than the originally applied current. This generated voltage also known as counter emf is usually proportional to the running speed of the motor, however, it never quite reaches the applied voltage level. This is due to inefficiencies in the motor system. A motor will draw a maximum amount of current when the counter emf is equal to zero during start. As it is turning it requires less and less current to operate.

The power consumed by a DC motor is transformed into heat energy and useful torque. When no load is applied to the motor shaft, only heat energy is consumed. A DC motor, thus draws its least amount of power when turning at the fastest possible speed with no applied torque.

6.1.2 Motor Torque and Mechanical Power

A useful catalog specification is the torque of the motor. It is a measure of the amount of force a motor can apply to a mechanical load. The higher the torque rating, the more powerful the motor. Torque rating is usually listed in units of Lb-Ft, Oz-In, or Lb-in. Since torque is expressed in different units, it is often necessary to convert, the following equations will help in achieving this task.

$$\text{lb-ft} = (\text{oz-in})/192$$

$$\text{oz-in} = 192 * (\text{lb-ft})$$

$$\text{lb-ft} = (\text{lb-in})/12$$

$$\text{lb-in} = 12 * (\text{lb-ft})$$

$$\text{Oz-in} = 16 * (\text{lb-in})$$

$$\text{lb-in} = (\text{oz-in})/16$$

Where lb-ft= torque rating in pound-feet, oz-in = torque rating in ounce-inches,
lb-in=torque rating in pound inches.[2]

Some motor specifications are expressed in terms of horsepower instead of torque. However, horsepower and torque are two different types of specification, one is a measure of mechanical power and the other a measure of work.

Mechanical power can be defined as the amount of work necessary to move a certain mass a given distance in a particular period of time.

$$P_h = (F*d)/(550*t) \quad \text{Equation 6.1}$$

Where P_h = mechanical power in horse power, F = force applied in pounds, d = distance moved in feet, t = time of motion in seconds.

Since DC motors are electrically operated devices, it is often helpful to express the mechanical power in terms of Watts instead of horsepower. They both express the rate of doing work, the only difference is their constant of conversion.

$$P_w = 746*P_h \quad \text{Equation 6.2}$$

$$P_w = 1.36*F*d/t \quad \text{Equation 6.3}$$

Where P_w = mechanical power in watts, P_h = mechanical power in horse power, F = force applied in pounds, d = distance moved in feet, t = time of motion in seconds.

The reason for this preference is the straight forward relationship that exist between the mechanical power expressed in Watts and the electrical power rating of the motor also expressed in Watts. As a matter of fact these two figures would be identical if motor inefficiencies were not taken into account.

These inefficiencies are a result of several factors, including the gear arrangement that reduce the speed of the system in order to increase the overall torque capacity. The relationship between the mechanical output and the electrical power rating of the motor is illustrated in the following equation.

$$P_m = P_w/e \quad \text{Equation 6.4}$$

Where P_m = electrical power rating of the motor in watts, P_w = mechanical power required in watts, e = mechanical efficiency.

We are going to attempt, next, to develop some useful relationship between motor torque, rpm and power. Equation 6.5 express the mechanical power as a function of torque and rpm.

$$P = (2*\pi*L*M_r)/60 \quad \text{Equation 6.5}$$

Where P= mechanical power in ft-lb/sec, L= torque in lb-ft, and M_r= motor speed in rpm.

From the previous expression we can solve for the horsepower using equation 6.1.

$$P_h = (2*\pi*L*M_r)/(60*550)$$

This expression can be further decomposed in order to develop an expression for the power in watts.

$$P_w = (1.36*2*\pi*L*M_r)/60$$

By working out the various constants these two previous equations can be summarized into equations 6.6 and 6.7.[2]

$$P_h = 1.9*L*M_r*10\text{exp}(-4) \quad \text{Equation 6.6}$$

$$P_w = 0.14*L*M_r \quad \text{Equation 6.7}$$

6.2 Estimating Mechanical Requirements of Motors

In selecting a motor for an autonomous vehicle project, the first step is to determine the relevant mechanical specifications: the rpm, the torque, and the power requirements.

6.2.1 Mechanical Power and Torque

An AGV calls for the use of a drive wheel operated by a motor. The mechanical power required to drive that wheel can be initially expressed as followed.

$$P = F*d/t$$

With P= the power required in ft-lb/sec, F= the total weight that the system is expected to move, t= time required to move the weight a distance d;

d/t represents the speed of motion, therefore, the equation can be simplified as followed.

$$P = F \cdot s$$

Where s is the linear speed, F = the total weight that the system is expected to move, and P = the power required in ft-lb/s.

The mechanical power in terms of ft-lb/sec doesn't have any real meaning to most people, we should therefore convert this figure into horsepower and watts

$$P_h = F \cdot s / 550 \quad \text{Equation 6.8}$$

$$P_w = 1.36 \cdot F \cdot s \quad \text{Equation 6.9}$$

Where P_h = required horsepower, P_w = power in watts, F = system weight, s = linear speed of the vehicle.

Equations 6.8 and 6.9 are instrumental in understanding the nature of an autonomous vehicle. As we can observe from these equations, the available power is directly proportional to the product of the weight and speed of the overall system. In other words, as the system gets heavier, more power is required to move it. Furthermore, the faster the system, the more power is required.

6.2.2 Motor Rpm

Determining the horsepower is not the only parameter necessary in designing a motor. In order to achieve the desired linear speed, the motor must develop a certain rpm. The following section is going to be devoted to determining mathematical relationships between the rpm and other important motor specifications.

With each revolution a wheel travels a distance equal to its circumference.

$$d = 2 \cdot \pi \cdot r$$

Where d = linear distance moved with each wheel revolution, r = radius of the wheel.

Since the motor is going to turn more than once, we must take that into account with the variable n , the number of complete revolutions.

$$d = 2 * \pi * n * r$$

However, the number of revolutions is highly impractical, therefore we must replace it with a turning rate multiplied by the time of observation.

$$n = (M_r * t) / 60$$

Where M_r = the rotational rate of the wheel in rpm.

By substituting the previous expression in the equation for distance we get:

$$d = (2 * \pi * M_r * t * r) / 60$$

Dividing both side by t , we obtain an equation for the speed s .

$$s = (2 * \pi * M_r * r) / 60$$

We can now solve for M_r , the wheel rpm, as a function of the speed of the vehicle.

$$M_r = (60 * s) / (2 * \pi * r)$$

Normally it is preferable to express the speed in ft/s and express the wheel size in terms of the diameter.

$$M_r = (720 * s) / (\pi * D) \quad \text{Equation 6.10}$$

This equation shows that the rpm of a wheel is directly proportional to the speed. Furthermore we can observe that for a given rpm, the machine can move faster by increasing the wheel diameter. [2]

6.2.3 Determining the Useful Torque

From equation 6.5 we can solve for the torque.

$$L = (60 * P) / (2 * \pi * M_r)$$

By substituting $P = F * S$ from equation 6.9 we obtain.

$$L = (60 * f * s) / (2 * \pi * M_r)$$

This constitute the equation for the useful torque or the required amount of output torque for the system.

6.2.4 Motor Gear Arrangement

There are two methods of transferring motor power to the drive wheel. In the first one a gear motor is used, it is directly assembled to the axle of the wheel. The gear motor torque and rpm are directly transferred to the drive wheel.

The second method includes a gear pulley arrangement inserted between the output shaft of the motor assembly and the drive wheel. Figure 6.1 illustrates this arrangement

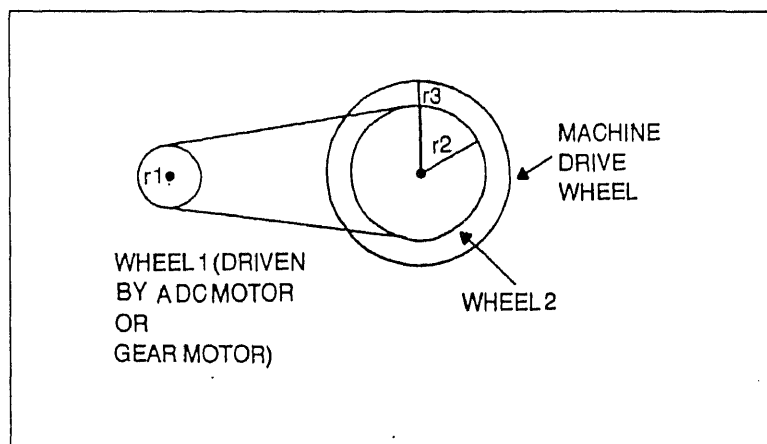

Figure 6.1 Motor Gear Arrangement.[2]

The shaft of the motor is attached to wheel 1. The wheel with radius r_2 is fastened to the shaft of the drive wheel. The mechanical arrangement between wheels 1 and 2 is achieved by a chain or belt connection.

The power at wheel 1 and 2 is the same, therefore $P_1 = P_2$. Using equation 6.6, we get:

$$(2 * \pi * L_1 * M_{r1}) / 60 = (2 * \pi * L_2 * M_{r2}) / 60$$

After canceling like terms this equation reduces to:

$$L_1 * M_{r1} = L_2 * M_{r2}$$

By substituting elements from equation 6.11 we get:

$$M_{r1} / M_{r2} = r_2 / r_1$$

In summary the following three equations result from the gear arrangement in figure 6.1.

$$L_1 * M_{r1} = L_2 * M_{r2} \quad \text{Equation 6.11}$$

$$M_{r1} * r_1 = M_{r2} * r_2 \quad \text{Equation 6.12}$$

$$L_2 * r_1 = L_1 * r_2 \quad \text{Equation 6.13}$$

Where L_1 = torque at wheel 1, L_2 = torque at wheel 2, M_{r1} = rotational rate of wheel 1, M_{r2} = rotational rate of wheel 2, r_1 = radius of wheel 1, and r_2 = radius of wheel 2

If the radius of wheel 2 is greater than wheel 1, wheel 2 will turn at a slower rate than wheel 1. However, what is lost in rpm is gain in torque.

6.3 Motor Circuit and Direction Control

The most basic types of motor control circuit is a single pole single throw toggle switch or a normally open push button switch, connected in series with a motor and a power supply.

When the toggle or push button is manually set at the on position, with the completion of the electrical circuit, the motor starts running. Likewise, when these two switches are set at the normally off position, the motor stops running.

The flexibility of this type of circuits is greatly improved by introducing a normally closed microswitch in series in the circuit. With this addition the motor is still controlled by the toggle switch, however, for a given set of circumstances the microswitch can be forced open. As a result of this, the motor would stop running. This micro switch can be activated by some form of sensor that prevents collisions. Combinations of microswitches can take care of any obstacle avoidance scheme. However, with the availability of low cost integrated circuits, it is not good practice to use arrays of microswitches in a circuit.

6.3.1 Introduction To Relays

Autonomous locomotion precludes a certain degree of sophistication in the controlling mechanism of the motor. It is common practice to incorporate relays in the usual switching scheme.

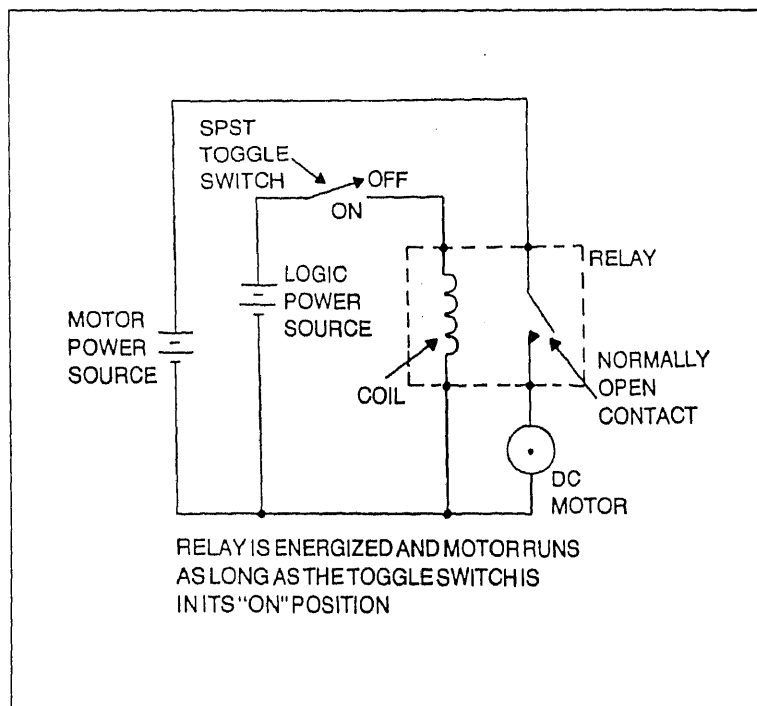

Figure 6.2 Motor Relay Interface in a Basic Circuit.[2]

In figure 6.2 a relay is introduced in a simple on and off motor circuit. The system is composed two different power supplies: the motor power source, and the logic power source. The relay is composed of a coil mechanism and a normally open contact. When the coil is energized the contact closes, allowing current flow to the motor. The coil mechanism is activated by the logic power source, this results in the electrical isolation of the motor and the logic circuitry.

With current isolation, the operation of a high current motor can be controlled from a low current logic circuit. Furthermore, by using separate sources of power, surges in the motor circuit have no adverse effect on the logic circuitry.

Voltage isolation is also realized between the motor and logic circuitry as a result of using relays. This means that a low power logic device can control a high voltage motor with no relative difficulty.

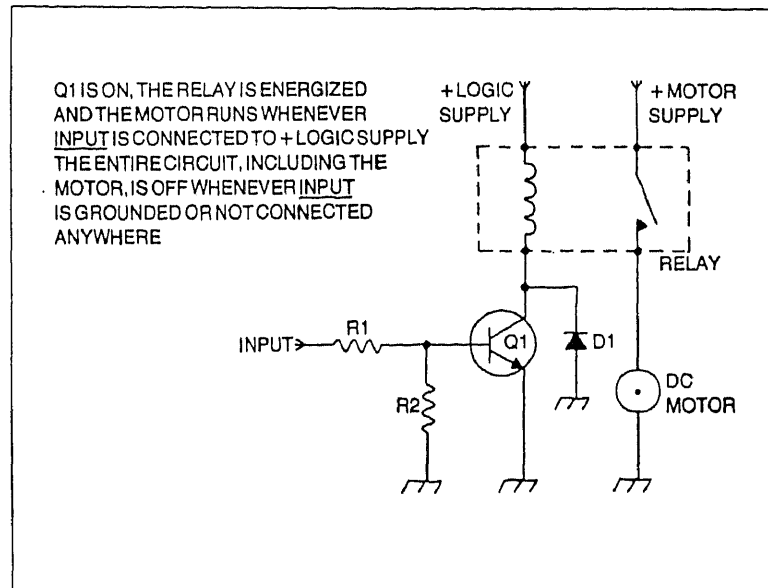

Figure 6.3 Controlling a Motor Relay with a Transistor.[2]

Figure 6.3 presents a more practical application of relays in a motor circuit. The relay is energized by an electrical signal from the logic circuitry applied to transistor Q1. The necessity for using a transistor stems from difference in current rating between the relay coil and the logic circuit. The transistor boost the current from the logic circuitry allowing it to interact with the relays.

The transistor is activated by connecting the input to the positive side of the logic supply. It is turned off by connecting the input to ground or not making any connection at all. Resistor R₁ limits the current to the base of the transistor. It can be selected by using the following equation.

$$R_1 = (V - 0.5) / I_b \quad \text{Equation 6.14}$$

Where V= the voltage applied to the input, I_b= the required base current.[2]

Resistor R2 turn the transistor off when the input is connected to ground or not connected. The diode D1 eliminates dangerous high voltage current spikes that occurs whenever the load at the input is turned off.

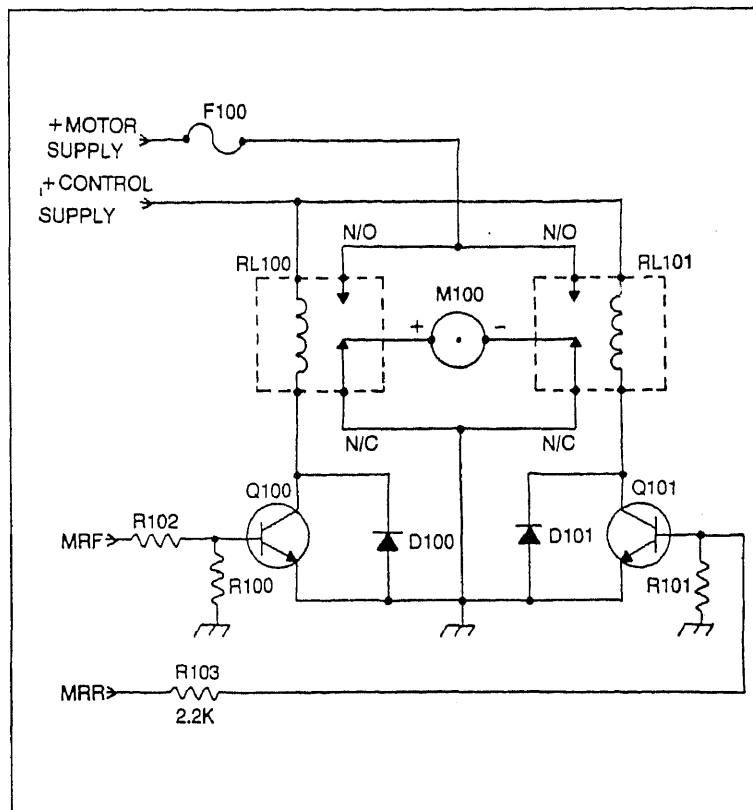

Figure 6.4 Two Direction Motor Control Circuit with Transistors and Separate Logic Supply Voltage.[2]

6.3.2 Two Direction Control Circuit Using Relays

Figure 6.3 presents the complete two direction motor control circuit. The logic inputs are at MRR and MRF. This circuit also incorporates two sources of power, one takes care of the motor and the other, the logic circuitry. Table 6.1 summarize the operation of this circuit. A logic level of 1 applied to either MRR or MRF will energize their respective relays. However the system will run only if opposite level of logic is applied to MRF and MRR. In the case where level 1 is applied to MRF and level 0 to MRR the motor will run

clockwise. With the opposite setting of level 1 at MRF and level 0 at MRR, the motor will turn counterclockwise. This type of circuit is ideal for the drive steer mechanism mentioned in chapter 2.

Table 6.1 FunctionTable for the Two Direction Motor Control Circuit Using Relays.

MRR	MRF	Response
0	0	stop
0	1	ccw run
1	0	cw run
1	1	stop

6.3.3 Two Direction Drive Steering Control Circuit

Figure A.5 in the appendix illustrates the two direction drive steering motor control circuit. It is equipped with transistor interfacing between the motor control circuit and the electronic circuitry. The inputs MRF and MRF control the right motor, MLF and MLR control the left motor. When a level 0 logic is applied to MRF, transistor Q104 is activated and in turn activates transistor Q100 which energizes relay RL100. Provided that level 0 is not applied at MRR, the right motor will run in a forward direction. Table 6.2 summarizes the various operation of the circuit.

Table 6.2 Function Table for the Two Direction Two Drive-Steer Control Circuit.[2]

$\overline{\text{MLR}}$	$\overline{\text{MLF}}$	$\overline{\text{MRR}}$	$\overline{\text{MRF}}$	LEFT MOTOR	RIGHT MOTOR	MOTOR RESPONSE
0	0	0	0	stop	stop	stop
0	0	0	1	stop	forward	fwd, left turn
0	0	1	0	stop	reverse	rev, left turn
0	0	1	1	stop	stop	stop
0	1	0	0	forward	stop	fwd, right turn
0	1	0	1	forward	forward	forward
0	1	1	0	forward	reverse	cw spin
0	1	1	1	forward	stop	fwd, right turn
1	0	0	0	reverse	stop	rev, right turn
1	0	0	1	reverse	forward	ccw spin
1	0	1	0	reverse	reverse	reverse
1	0	1	1	Reverse	Stop	Rev, right turn
1	1	0	0	Stop	Stop	Stop
1	1	0	1	Stop	Forward	Fwd, left turn
1	1	1	0	Stop	Reverse	Rev, left turn
1	1	1	1	Stop	Stop	Stop

CHAPTER 7

CONCLUSION

The design of an automated guided Vehicle is not a simple task. Careful planning is required, in order to achieve a system that operates efficiently. In this project we have managed to provide a hands on approach at designing an autonomous vehicle. This includes the various methods that we generated while designing and building an AGV at the Center for Manufacturing Systems.

With technological advances in electronic sensing and reasoning, a new generation of mobile vehicles will be able to better cope with unstructured domains. One of the areas that will be able to benefit the most from the wave of new technology is the power supply system. Most of the systems available today, provide a relatively short operating duty cycle which prevents the vehicles from functioning for extended period of times. A technique we used to prevent this is by utilizing two set of batteries with one set always being charged.

The ever-present noise problem in an AGV project was resolved with amplifiers. This enabled the various electronic hardware to distinguish the signals they are supposed to process.

APPENDIX A

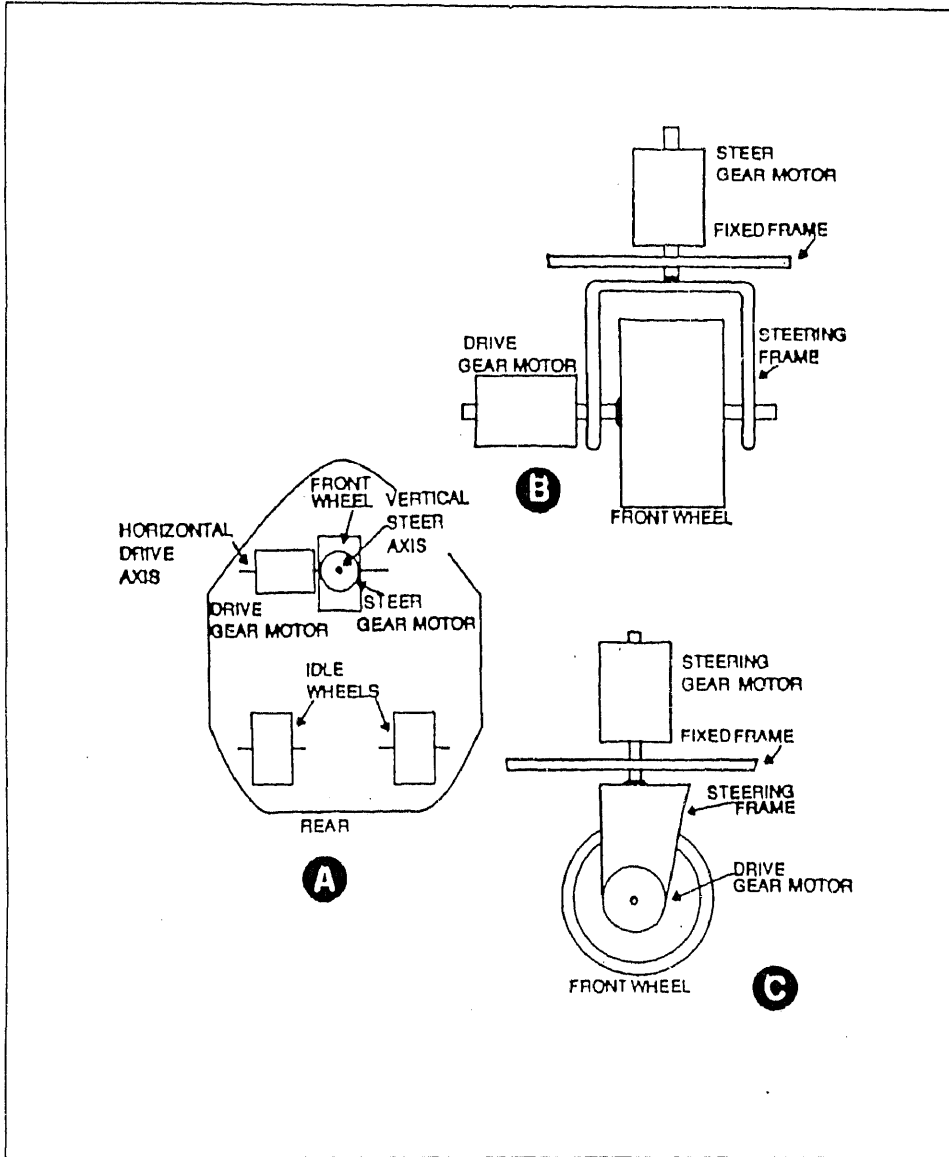

A.1 Drive and Steering Configuration Using Separate Motors for Steering and Driving. [2]

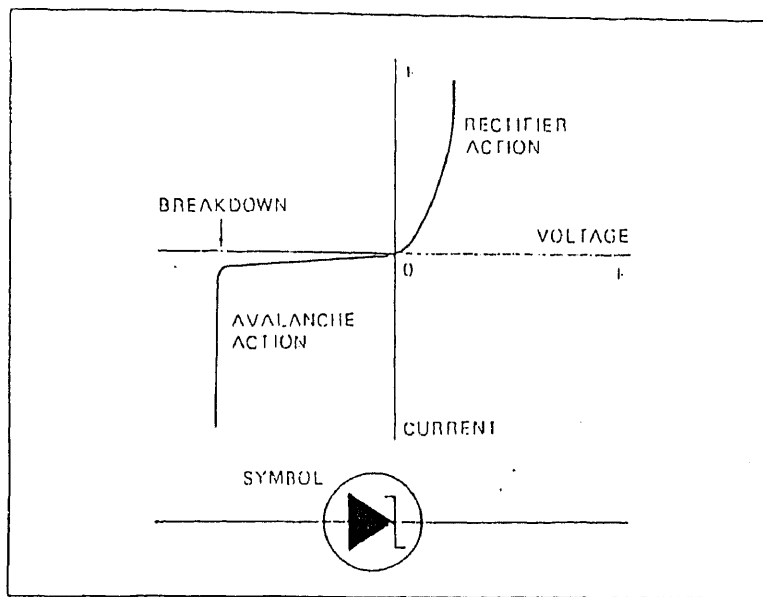

A.2 Rectifier Action and Avalanche Action of a Semiconductor. [3]

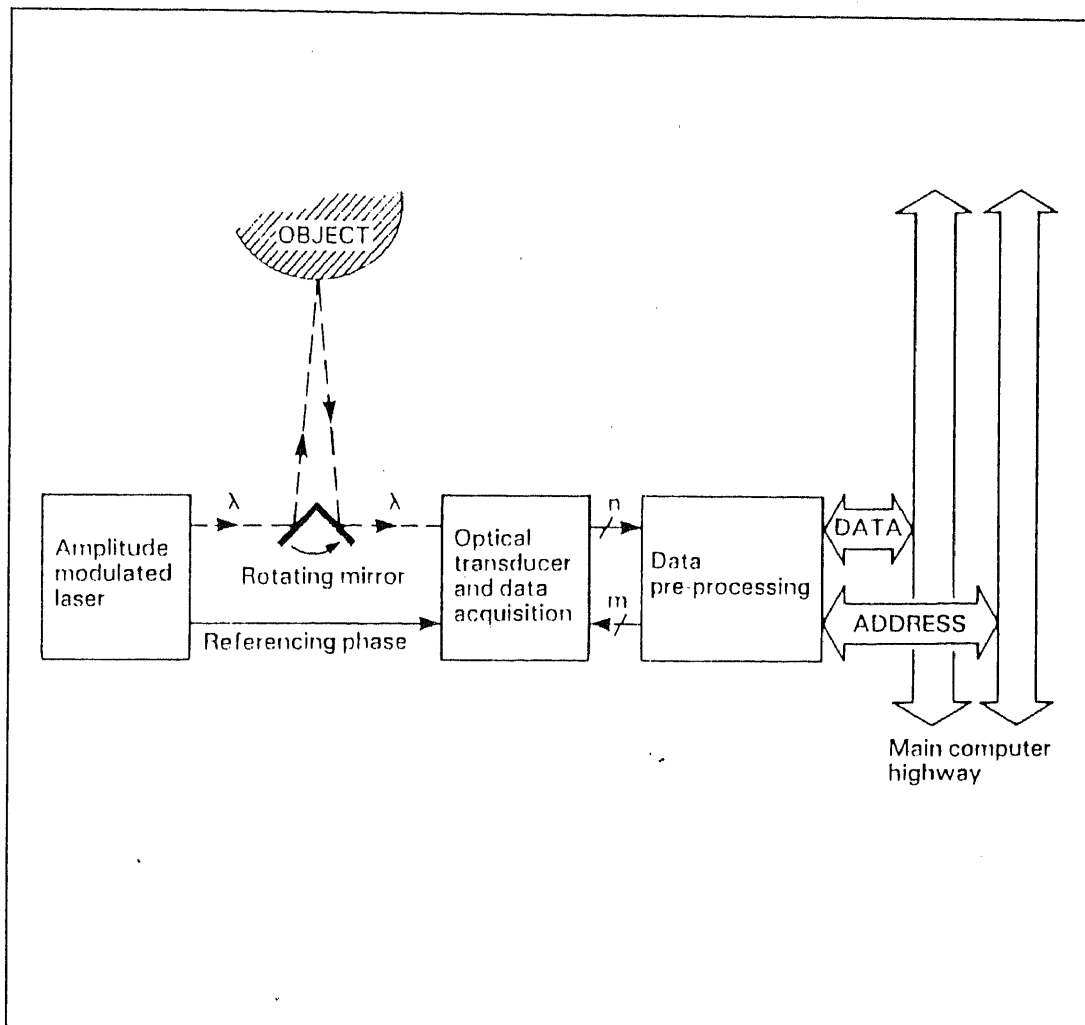

A.3 Generalized Block Diagram of a Scanning Lazer Range Finder.[5]

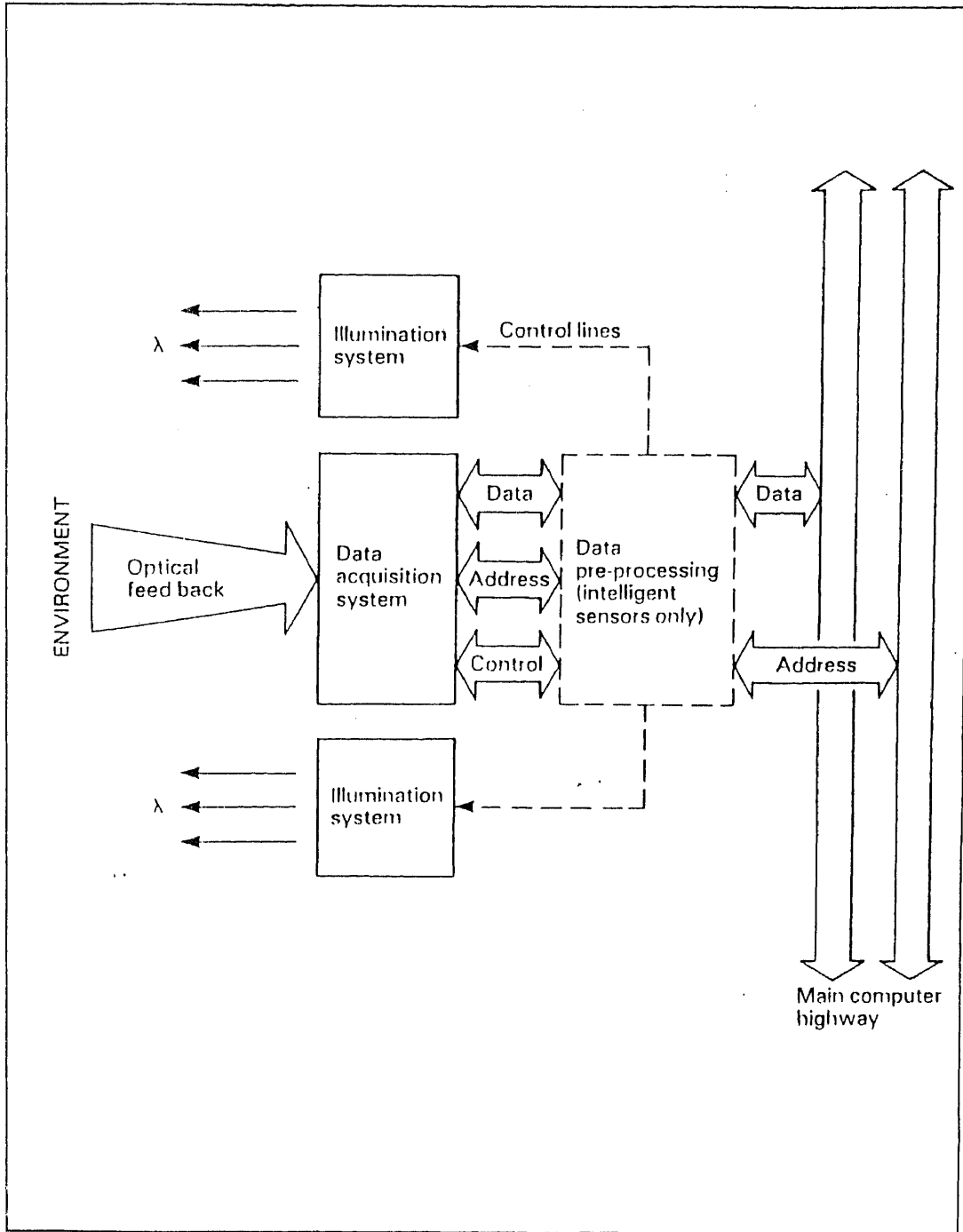

A.4 Generalized Block Diagram of a Vision Sensor.[5]

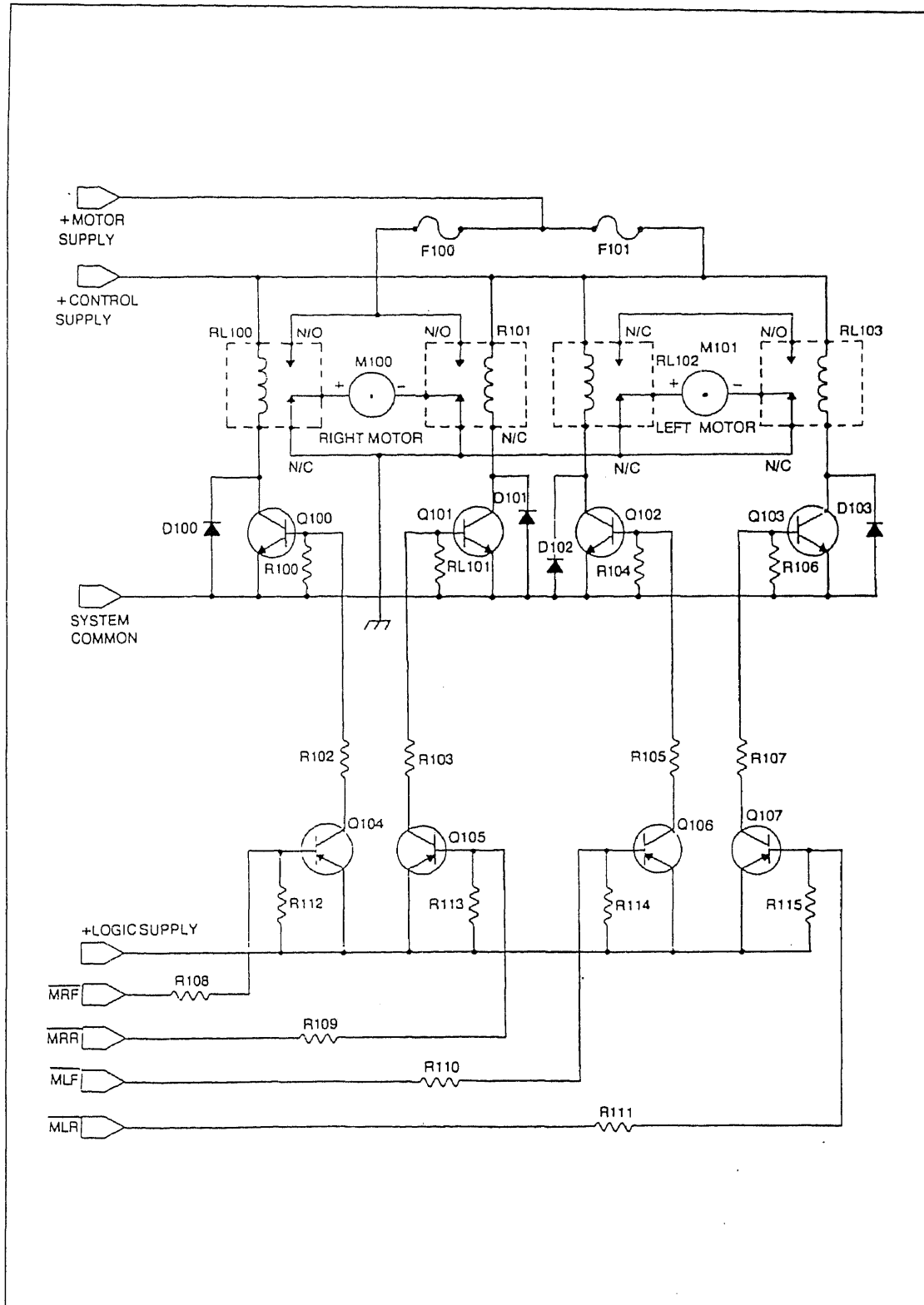

A.5 Two Direction Drive Control Circuit.[2]

REFERENCES

1. N. Zeuch and R. K. Miller, *Machine Vision*, Prentice-Hall, New Jersey, 1986.
2. D. L. Heizerman, *How To Design and Build Your Own Custom Robot*, Tab, Pennsylvania, 1980.
3. W. G. Holzbock, *Robotic Technology*, Reinhold, New York, 1986.
4. R. A. Pearman, *Power Electronics*, Reston, Virginia, 1980.
5. S. R. Ruocco, *Robot Sensors and Transducers*, Wiley, New York, 1987.
6. J. A. Wilson, *Industrial Electronics and Control*, Science Research Associates, Chicago, 1978.
7. S. N. Nof, *Robotics and Material Flow*, Elsevier, New York, 1986.
8. Kimberley, H. R., and R. Madarasz. 1989. "A Visual Guidance System Based on Optic Flow Information". 1989 World Conference on Robotics. 3: 27-37
9. J. J. Gibson, *The Senses Considered as Perceptual Systems*, Corneil University Press, New York, 1966.