

## **Copyright Warning & Restrictions**

The copyright law of the United States (Title 17, United States Code) governs the making of photocopies or other reproductions of copyrighted material.

Under certain conditions specified in the law, libraries and archives are authorized to furnish a photocopy or other reproduction. One of these specified conditions is that the photocopy or reproduction is not to be “used for any purpose other than private study, scholarship, or research.” If a user makes a request for, or later uses, a photocopy or reproduction for purposes in excess of “fair use” that user may be liable for copyright infringement,

This institution reserves the right to refuse to accept a copying order if, in its judgment, fulfillment of the order would involve violation of copyright law.

**Please Note: The author retains the copyright while the New Jersey Institute of Technology reserves the right to distribute this thesis or dissertation**

Printing note: If you do not wish to print this page, then select “Pages from: first page # to: last page #” on the print dialog screen

The Van Houten library has removed some of the personal information and all signatures from the approval page and biographical sketches of theses and dissertations in order to protect the identity of NJIT graduates and faculty.

## INFORMATION TO USERS

This manuscript has been reproduced from the microfilm master. UMI films the text directly from the original or copy submitted. Thus, some thesis and dissertation copies are in typewriter face, while others may be from any type of computer printer.

**The quality of this reproduction is dependent upon the quality of the copy submitted.** Broken or indistinct print, colored or poor quality illustrations and photographs, print bleedthrough, substandard margins, and improper alignment can adversely affect reproduction.

In the unlikely event that the author did not send UMI a complete manuscript and there are missing pages, these will be noted. Also, if unauthorized copyright material had to be removed, a note will indicate the deletion.

Oversize materials (e.g., maps, drawings, charts) are reproduced by sectioning the original, beginning at the upper left-hand corner and continuing from left to right in equal sections with small overlaps. Each original is also photographed in one exposure and is included in reduced form at the back of the book.

Photographs included in the original manuscript have been reproduced xerographically in this copy. Higher quality 6" x 9" black and white photographic prints are available for any photographs or illustrations appearing in this copy for an additional charge. Contact UMI directly to order.

# U·M·I

University Microfilms International  
A Bell & Howell Information Company  
300 North Zeeb Road, Ann Arbor, MI 48106-1346 USA  
313/761-4700 800/521-0600

**Order Number 9322434**

**Investigation of the Consumer Electronics Bus**

**Yang, Jaesoo, Ph.D.**

**New Jersey Institute of Technology, 1993**

**Copyright ©1993 by Yang, Jaesoo. All rights reserved.**

**U·M·I**  
300 N. Zeeb Rd.  
Ann Arbor, MI 48106

# INVESTIGATION OF THE CONSUMER ELECTRONICS BUS

by  
Jaesoo Yang

A Dissertation  
Submitted to the Faculty of  
New Jersey Institute of Technology  
in Partial Fulfillment of the Requirements for the Degree of  
Doctor of Philosophy

Department of Electrical and Computer Engineering

January, 1993

**APPROVAL PAGE**

**Investigation Of The  
Consumer Electronics Bus**

**Jaesoo Yang**

---

Dr. C. N. Manikopoulos, Thesis Adviser  
Associate Professor of Electrical and Computer Engineering, NJIT

---

Dr. Sol Rosenstark, Committee Member  
Professor of Electrical and Computer Engineering, NJIT

---

Dr. Nirwan Ansari, Committee Member  
Assistant Professor of Electrical and Computer Engineering, NJIT

---

Dr. Dennis Karvelas, Committee Member  
Assistant Professor of Computer and Information Science, NJIT

---

Dr. Dan Celenti, Committee Member  
AT&T Bell labs. Middletown, NJ

---

Dr. Gihong Kim, Committee Member  
Vice President, Integrated Network Corporation Bridgewater, NJ

Copyright ©1993 by Jaesoo Yang  
**ALL RIGHTS RESERVED**

# ABSTRACT

## Investigation of the Consumer Electronics Bus

by  
Jaesoo Yang

The objectives of this dissertation are to investigate the performance of the Consumer Electronics Bus (CEBus) and to develop a theoretical formulation of the Carrier Sense Multiple Access with Contention Detection and Contention Resolution (CSMA/CDCR) with three priority classes protocol utilized by the CEBus.

A new priority channel assigned multiple access with embedded priority resolution (PAMA/PR) theoretical model is formulated. It incorporates the main features of the CEBus with three priority classes. The analytical results for throughput and delay obtained by this formulation were compared to simulation experiments. A close agreement has been found thus validated both theory and simulation models.

Moreover, the performance of the CEBus implemented with two physical media, the power line (PL) and twisted pair (TP) communication lines, was investigated by measuring message and channel throughputs and mean packet and message delays. The router was modeled as a node which can handle three priority levels simultaneously. Satisfactory performance was obtained.

Finally, a gateway joining the CEBus to ISDN was designed and its performance was evaluated. This gateway provides access to ISDN-based services to the CEBus. The ISDN and CEBus system network architecture, gateway wiring, and data and signaling interface between the CEBus and ISDN were designed, analyzed, and discussed. Again, satisfactory performance was found.



## BIOGRAPHICAL SKETCH

**Author:** Jaesoo Yang

**Degree:** Doctor of Philosophy in Electrical Engineering

**Date:** January, 1993

### **Undergraduate and Graduate Education:**

- Doctor of Philosophy in Electrical Engineering, New Jersey Institute of Technology, Newark, NJ, 1993
- Master of Science in Electronics, Konkun University, Seoul, Republic of Korea, 1985
- Bachelor of Science in Telecommunication Engineering, Seoul, Korea, 1981

**Major:** Electrical & Computer Engineering

### **Presentations and Publications:**

- Yang, J., and C. Manikopoulos. "Router Connected Physical Media in Networking the Intelligent Home." *IEEE Transaction on Consumer Electronics*, Vol. 38, No. 1, pp. 30-36, Feb. 1992.
- Yang, J., and C. Manikopoulos. "Investigation of the Consumer Electronics Bus with two Physical Media Connected with a Router." (with Prof. C. N. Manikopoulos, NJIT) submitted to and accepted by *Journal of Telecommunication Systems*, 1992.

- Yang, J., and C. Manikopoulos. "The Consumer Electronics Bus Interconnected by a Controlled Router." *The Twenty-Third Annual Pittsburgh Conference on Modeling and Simulation*, April 30 - May 1, 1992. (with Prof. C. N. Manikopoulos, NJIT)
- Yang, J., and C. Manikopoulos. "Optimum Packet Length and Buffer Sizes of the Consumer Electronics Bus." *The Twenty-Third Annual Pittsburgh Conference on Modeling and Simulation*, April 30 - May 1, 1992.
- Yang, J., and C. Manikopoulos. "Determination of the Optimum Packet Length and Buffer Sizes for the Consumer Electronics Bus." *IEEE Transaction on Consumer Electronics*, Vol. 38, No. 4, Nov. 1992.
- Yang, J., and C. Manikopoulos. "Investigation of the Performance of a Controlled Router for the CEBus." *IEEE Transaction on Consumer Electronics*, Vol. 38, No. 4, Nov. 1992.
- Yang, J. "*Wire Communication Engineering*," Pages 770, 1987.

This thesis is dedicated to  
my wife, Hyun Ju,  
my son, Hyun Seok,  
and to the memory of my parents

## ACKNOWLEDGMENT

The author gratefully acknowledges the encouragement afforded by the Department of Electrical and Computer Engineering, New Jersey Institute of Technology. In particular, the author would like to express his appreciation to his research advisor Dr. Constantine N. Manikopoulos for his patient guidance and counsel during the course of this research. Thanks are also due to other members of his thesis committee, Drs. S. Rosenstark, N. Ansari, D. Karvelas, D. Celenti, and G. Hong for taking time to review this work.

Also his gratitude is extended to the members of the Computer Network and Intelligent Systems Laboratory at New Jersey Institute of Technology. The author is particularly grateful to Mr. Steve Lin for his help in programming. Thanks are to Dr. Pawel Gburzynski and Dr. Piotr Rudnicki of the University of Alberta who developed the LANSF Protocol Modeling Environment software tool. The author also wishes to express his gratitude to his friends who have given encouragement during this doctoral program.

The author also acknowledges the assistance provided by Korea Telecom in Korea in the form of a scholarship which funded his graduate studies. Thanks are also due to the members of New York Liason Office of the KT for their encouragement.

Most of all thanks are extended to God for His supporting love, hope, and blessing during the doctoral program, and the inspiration provided me at moments of frustration and despair. Thanks are also due to his church members.

Finally, the author would like to extend a special thanks to the sacrifices of his wife and son during his study. They had to endure loneliness during the many weekends and evenings the author spent studying at school which otherwise would have been spent in their company. Special thanks also go to his mother-in-law for helping him a lot. The encouragement, patience, and help in typing the manuscript provided by his wife helped him to carry out this research to finish.

# TABLE OF CONTENTS

Chapter	Page
<b>1 INTRODUCTION</b> .....	<b>1</b>
1.1 Background .....	1
1.2 Contributions of this Dissertation .....	3
1.3 Outline of the Dissertation .....	4
<b>2 CEBUS ARCHITECTURE AND PROTOCOL</b> .....	<b>7</b>
2.1 Background .....	7
2.2 Channel Access Protocol .....	8
2.2.1 Prioritization .....	11
2.2.2 Minimum Channel Access Delay (State Deference) .....	12
2.2.3 Queueing and Round-robin Scheduling .....	12
2.2.4 Randomization .....	13
2.2.5 Contention Detection and its Resolution .....	14
2.2.6 Error Detection .....	15
<b>3 CEBUS THEORETICAL ANALYSIS</b> .....	<b>17</b>
3.1 General .....	17
3.2 Priority Channel Assigned Multiple Access with Embedded Priority Reservation .....	23
3.2.1 Analysis Methodology and Algorithm .....	23
3.2.2 Transition Matrices .....	34
3.2.3 Expected Length of Cycles and Backlogs of each Priority ..	50
3.2.4 Throughput and Delay Performance .....	57
3.3 Numerical Analysis and Discussion .....	59
3.4 Summary .....	72

<b>4</b>	<b>PERFORMANCE WITH THREE PRIORITY ROUTER</b> .....	<b>76</b>
4.1	General .....	76
4.2	Brief Description of the CEBus Protocol .....	77
4.3	Simulation Experiments .....	79
4.3.1	Router .....	79
4.3.2	Network Model and Traffic Patterns .....	80
4.4	Summary .....	91
<b>5</b>	<b>CEBUS TO ISDN GATEWAY DESIGN</b> .....	<b>93</b>
5.1	Back Ground .....	93
5.2	The ISDN .....	94
5.2.1	ISDN Interfaces .....	94
5.2.2	ISDN User Channels .....	96
5.2.3	Basic and Primary Interfaces .....	98
5.2.4	User-to-User Signaling .....	100
5.3	ISDN Home Information Services .....	101
5.3.1	ISDN Applications for the CEBus .....	104
5.3.2	Gateway Wiring and ISDN Home Informations System Architecture .....	106
5.4	CEBus Gateway Design and Its Interface to the ISDN .....	107
5.5	Simulation Network Model .....	110
5.6	Simulation Measurements .....	114
5.7	Summary .....	123
<b>6</b>	<b>CONCLUSIONS</b> .....	<b>127</b>
6.1	Research Summary .....	127
6.2	Suggestions for Further Study .....	131
	<b>BIBIOGRAPHY</b> .....	<b>133</b>

# LIST OF TABLES

Table	Page
2.1 Symbol Duration of the Preamble . . . . .	10
3.1 Example of Parameters and Numerical Values . . . . .	61

# LIST OF FIGURES

Figure	Page
2.1 Power Line (PL) Control Channel . . . . .	9
2.2 Channel Access Wait Time of Prioritization and Queuing Scheme . . . . .	11
2.3 Example of Contention Detection and Contention Resolution . . . . .	14
3.1 Priority Resolution and Embedded Slots . . . . .	26
3.2 The Various Situations in High Priority Transmission . . . . .	30
3.3 Time Sequence of Events for Standard Priority Message Transmission . . . . .	31
3.4 Time Sequence of Events for Deferred Priority Message Transmission . . . . .	33
3.5 Arrival Transition during the Minimum Wait and Priority Channel Access Delay Time . . . . .	37
3.6 Comparisons of Throughput by Numerical Analysis and Simulation as a Function of Offered Load when Packet Lengths are 50, 200 bits, respectively . . . . .	63
3.7 Comparisons of Throughput by Numerical Analysis and Simulation as a Function of Offered Load when Packet Lengths are 500, 1000 bits, respectively . . . . .	63
3.8 Comparisons of Delays by Numerical Analysis and Simulation as a Function of Offered Load when Packet Length is 50 bits. . . . .	65
3.9 Comparisons of Delays by Numerical Analysis and Simulation as a Function of Offered Load when Packet Length is 200 bits. . . . .	65
3.10 Comparisons of Delay by Numerical Analysis and Simulation as a Function of Offered Load when Packet Length is 500 bits. . . . .	67
3.11 Comparisons of Delay by Numerical Analysis and Simulations as a Function of Offered Load when Packet Length is 1000 bits. . . . .	67
3.12 Delay in slots as a Function of Packet Size. . . . .	68
3.13 Effect of Persistent Mechanism with respect to Packet Delay versus Traffic Load at Packet Length=200. . . . .	69
3.14 Packet Delay versus Normalized Throughput for Three different $P$ -persistent values at Packet Length = 50 bits. . . . .	70



3.15	Packet Delay versus Normalized Throughput for Three different $P$ -persistent values at Packet Length = 500 bits. . . . .	70
3.16	Message and Packet Delay Comparison versus Normalized Traffic Load with Packet Length=300 bits . . . . .	73
4.1	Flowchart of the Node Transmitter . . . . .	81
4.2	Flowchart of the Node Receiver . . . . .	84
4.3	Message and Channel Throughput versus Offered Load for Intra-network Traffic of PL and Inter-network Traffic from PL to TP. . . . .	87
4.4	Message and Channel Throughput versus Offered Load for Intra-network Traffic of the TP and Inter-network Traffic from TP to PL. . . . .	87
4.5	Message and Packet Delay versus Offered Load for Intra-network Traffic on the PL with Packet Length 300 bits . . . . .	88
4.6	Message and Packet Delay versus Offered Load for Inter-network Traffic from PL to TP with Packet Length 300 bits . . . . .	89
4.7	Mean Packet Delay versus Offered Load for Intra-network Traffic on TP and for Inter-network Traffic from TP to PL with Packet Length 300 bits . . . . .	89
4.8	Mean Message Delay versus Offered Load for Intra-network Traffic of the TP and Inter-network Traffic from TP to PL. . . . .	90
5.1	User-to-Network Interface Types . . . . .	95
5.2	ISDN and CEBus Network Structure . . . . .	101
5.3	Distribution Device with a NT. . . . .	106
5.4	Data and Signaling Interface between the CEBus and the ISDN Networks	109
5.5	Network Simulation Model through the Gateway . . . . .	111
5.6	Message and Channel Throughput versus Normalized Offered Load with Packet Length 200 bits on the CEBus . . . . .	115
5.7	Mean Message Throughput versus Offered Load for Inter-network Traffic from ISDN to CEBus/PL and vice versa with Zero Propagation Delay	115
5.8	Mean Message Delay for Inter-network Traffic versus Normalized Offered Load from CEBus/PL to ISDN and vice versa with Zero Propagation	117

5.9	Message and Packet Delays versus Offered Load for Intra-network Traffic on PL Medium with Packet Length 200 bits and Zero Propagation Delay . . . . .	117
5.10	Channel and Message Throughputs, and Message Delay for Intra-network Traffic on PL Medium versus Normalized Offered Load with Packet Length 1,000 bits and Zero Propagation. . . . .	118
5.11	Message Throughputs for Inter-network Traffic from ISDN to CEBus/PL and vice versa as a function of Normalized Offered Load with Packet Length 1,000 bits and Zero Propagation. . . . .	118
5.12	Global Message and Channel Throughputs versus Offered Load for Intra-network Traffic on PL Medium with Packet Length 200 bits and Different Propagation Delay. (a) $P_0 = 0$ bit, (b) $P_1 = 1$ bit, and (c) $P_5 = 5$ bits. . . . .	119
5.13	Message Throughput through Gateway from ISDN to CEBus as Function of Normalized Offered Load with Packet Length 200 bits and Different Propagation. . . . .	121
5.14	Message Throughput through Gateway from CEBus to ISDN as Function of Normalized Offered Load with Packet Length 200 bits and Different Propagation. . . . .	121
5.15	Mean Message Delay through Gateway from ISDN to CEBus as Function of Normalized Offered Load with Packet Length 200 bits and Different Propagation. . . . .	122
5.16	Mean Message Delay through Gateway from CEBus to ISDN as Function of Normalized Offered Load with Packet Length 200 bits and Different Propagation. . . . .	122
5.17	Mean Message Delay through Gateway from ISDN to CEBus as Function of Normalized Offered Load (magnified from Fig. 5.15). . .	124



## LIST OF SYMBOLS

SYMBOLS	EXPLANATIONS
$a_i^{(p)}(k)$	Probability that $k$ users in the thinking state transmit in a slot when the number of backlogged users is $i$ , within priority $p$ .
$a(\alpha_h, \alpha_s, \alpha_d)$	Probability of multiplied new arrival of High, Standard, and Deferred priority during minimum wait time ( $w_m$ ).
$A_p$	Time sequence combination of $A_h, A_s$ and $A_d$ , i.e., $A_h = 0$ to 4, $A_s = 5$ to 8 and $A_d = 9$ to 12 slots. Subscript $p$ stands for $h, s$ , and $d$ which denote High, Standard, and Deferred priorities, respectively.
$A_h$	High Priority contention period=4 slots, following $w_m$ . Here $w_m$ is minimum wait time, i.e., 8 slots.
$A_s$	Standard Priority contention period= 4 slots, following $w_m + A_h$
$A_d$	Deferred Priority contention period= 4 slots, following $w_m + A_h + A_s$
$b(\alpha_h, \alpha_s, \alpha_d)$	Probability of multiplied new arrival of High, Standard, and Deferred priority during minimum wait time ( $w_m$ ) + $A_h$ .
$b_i^{(p)}(k)$	Probability that $k$ backlogged users transmit in a slot when the number of backlogged users is $i$ , within priority $p$ .
$c(\cdot)$	Probability of multiplied new arrival of High, Standard, and Deferred priority during minimum wait time ( $w_m$ ) + $A_h + A_s$ .
$C_p$ -subcycle	Time between two successive $C_p$ -embedded points, i.e., Minimum waiting and Priority channel access delay time plus contention period of the priority.
$C_p$ -cycle	Average length of the priority $p$ . Subscript $p$ , standards for $h, s$ , and $d$ which denote High, Standard and Deferred Priorities, respectively.
$D_p$	Average delay of each priority.
$d_k^{(p)}$	probability that no user becomes ready during slot $t$ , when the number of backlog users is $k$ , i.e., $= (1 - \nu_p)^k (1 - g_p)^{M_p - k}$
$1 - d_k^{(p)}$	Probability of one or more users becoming ready during slot $t$ , when the backlog is $k$
$E[.]$	Expectation of the random variable.
$f_{i,j}$	Condition unsuccessful Transmission.

$[F_p]_{i,k}$	Transition probability matrix of priority $p$ from state $i$ to state $k$ with unsuccessful transmission.
$g_p$	In the thinking state, a user of each priority generates a new message in a slot with probability $g_p$ .
$g_h$	Probability that a user in the thinking state generates a new High priority message in a slot.
$g_s$	Probability that a user in the thinking state generates a new Standard priority message in a slot.
$g_d$	Probability that a user in the thinking state generates a new Deferred priority message in a slot.
$\bar{T}_k^{(p)}$	Mean idle period of priority $p$ .
$[J_p]_{i,k}$	Decrease in backlog after successful transmission, i.e., departure transmission probability.
$L_{n_h}$	Time slots it takes for the process $m_h(t_{ph})$ to reach state 0, i.e., $T_{ps}^{(r+1)} - t'_p \equiv \beta$ .
$L_{n_h}^*(z)$	Generating function for $L_{n_h}$ .
$L_{n_h, n_s}$	Time slots it takes for the process $m_h(t_{ph})$ and $m_s(t_{ps})$ to reach state 0, i.e., $T_{pd}^{(r+1)} - t'_p \equiv u$ .
$L_{n_h, n_s}^*(z)$	Generating function for $L_{n_h, n_s}$ .
$M$	Total number of users.
$M_h$	Total number of High priority messages.
$M_s$	Total number of Standard priority messages.
$M_d$	Total number of Deferred priority messages.
$m_p$	Number of backlogged users at the beginning of slot $t$ .
$m_p(t)$	The number of backlogged users in a slot $t$ .
$M_p - m_p(t)$	The number of users in the thinking state. $p$ denotes High, Standard, and Deferred Priority.
$n_h$	State of the system for the High priority at time $t'_p$ .
$n_s$	State of the system for the Standard priority at time $t'_p$ .
$\bar{N}_p$	Average channel backlog for priority $p$ .
$P_{r ps}^{(p)}$	Transition probability between $t'_{ps}^{(r)}$ and $t'_p$ with $p$ priority transmission, where $(p)$ denotes $a$ , $b$ and $c$ , and each notation represents the multiplied probability of the high, standard and deferred priority over the specified duration.

$P_{r pd}^{(p)}$	Transition probability between $t_{pd}^{(r)}$ and $t'_p$ with $p$ priority transmission.
$P_{suc}^{(p)}(k)$	Probability of a successful transmission of the priority $p$ during a $C_p$ -cycle given $m_p(t_p(t)) = k$ .
$[P_p]_{i,j}$	Transition matrix element at two embedded points for priority $p$ .
$q_{h;i,j}$	Length of the $C_h$ -subcycle, i.e., $t_{ph}^{(r+1)} - t_{ph}^{(r)}$ .
$q_{h;i,j}^*(z)$	Generating function of the probability mass function of $q_{h;i,j}$ .
$q_{n_h,j_h;n_s,j_s}$	Length of the combination of $C_h$ - and $C_s$ -subcycles, i.e., combination of $t_{ph}^{(r+1)} - t_{ph}^{(r)}$ and $t_{ps}^{(r+1)} - t_{ps}^{(r)}$ .
$q_{n_h,j_h;n_s,j_s}^*(z)$	Generating function of the probability mass function of $q_{n_h,j_h;n_s,j_s}$ .
$Q_k^{(f)}$	Duration of unsuccessful transmission for High priority.
$Q_k^{(s)}$	Duration of successful transmission for High priority.
$Q_k^{(f)*}(z)$	Moment generating function for $Q_k^{(f)}$ .
$Q_k^{(s)*}(z)$	Moment generating function for $Q_k^{(s)}$ .
$[Q_p]_{i,k}$	Arrival transition probability of the priority $p$ in a slot, i.e., arrival rate transmission probability
$[Q_p^T]_{i,k}$	Arrival transition probability of the priority $p$ having $k - i$ new arrivals among $M - i$ users in $T$ slots
$s_{i,j}$	Conditional successful transmission probability.
$S_p$	Average stationary channel throughput for the priority $p$ .
$[S_p]_{i,k}$	Probability of transition of priority $p$ from state $i$ to state $k$ with successful transmission.
$TP_p$	Length in slots of a message of class $C_p$ , i.e., transmission period. $TP_p = T_p + 1$ in case of success, or $T_{cp} + 1$ in case of failure, where the additional slot 1 accounts for the propagation delay.
$T_p$	Length in slots of message priority $p$ with successful transmission.
$T_{cp}$	Unsuccessful busy periods in slots of priority $p$ until a collision is detected.
$t_p$	Observation time instant in time.
$t'_p$	Time of the first EOP following $t_p^{(r)}$
$(t_p)^{(r)}, (t_p)^{(r+1)}$	Two consecutive embedded points.
$(t_p)^{(r)} - (t_p)^{(r+1)}$	Length of the $C_p$ -subcycle.

$\nu_p$	Probability that a user in the backlogged state transmit a priority $p$ message with a geometrically distributed delay with mean $1/\nu_p$ .
$X_k^{(f)}$	Duration of unsuccessful transmission for Standard priority.
$X_k^{(s)}$	Duration of successful transmission for Standard priority.
$X_k^{(f)*}(z)$	Moment generating function for $X_k^{(f)}$ .
$X_k^{(s)*}(z)$	Moment generating function for $X_k^{(s)}$ .
$X_k^{l*}(z)$	Transient moment generating function during $l$ slots over the Standard priority.
$Y_k^{(p)}$	Duration of $C_d$ -cycle, i.e., $w_m + I_k^{(d)} + TP_d$ , here $TP_d$ indicates $T_d + 1$ in case of success, and $T_{cd} + 1$ in case of failure, and $(p)$ denotes one of $s$ (successful) and $f$ (failure).
$Y_k^{(p)*}(z)$	Moment generating function for $Y_k^{(p)}$ .
$Y_k^{l*}(z)$	Moment generating function during $l$ slots over the Deferred priority.
$\Pi_j^p$	Stationary distribution of the Markov chain of the priority $p$ .

# CHAPTER 1

## INTRODUCTION

### 1.1 Background

The Consumer Electronic Bus (CEBus) for the intelligent home, sponsored by the Electronic Industries Association(EIA) [1], is a local area network for communication and control within a house. The CEBus is intended to support home communication for remote sensing and control, status indication, security monitoring and control, energy management, entertainment facilities, lighting automation, home appliances, etc. It provides a standardized communications interface to six different physical communication media [1]-[5]: PLBus (Power Line Bus), TPBus (Twisted-Pair Bus), CXBus (Coaxial Bus), SRBus (Infrared, or Single-Room Bus), RFBus (Radio Frequency Bus) and FOBus (Fiber-Optic Bus). It uses existing 60 Hz power lines as the main retrofit medium in the home. Since every house in the world is wired for electricity, the PL CEBus network is easy and inexpensive to install.

The EIA Consumer Electronics Group [4] began in 1984 an effort for the formulation of a standard for a home communication network focused on consumer products. Subsequently, a technical steering committee was formed under the Engineering Policy Council of the EIA to provide overall guidance and administration of the standards. Portions of the draft specification began being released for review in 1989. A revised specification was released in 1992. The CEBus standard sets out to achieve several objectives. First, it should be easy to retrofit. Also, it should be expandable over



time as new media and new technologies are adopted. The major technical development goals are versatility with both distributed and centralized control, simplicity of operation without special training or knowledge, low cost, compatibility regardless of manufacturer, support of multiple media and media independence.

A new language, the Command Application Language (CAL), has been specifically designed for the CEBus. It provides compatibility among supported devices. It also allows for extendability over time as new features and services are introduced.

The CEBus protocol utilizes Carrier Sense Multiple Access with Contention Detection and Contention Resolution (CSMA/CDCR) for channel access. The round robin queueing scheme, based on the queueing state, has been employed in order to provide equal opportunity to transmit within a priority. Three priority classes of messages HIGH, STANDARD, and DEFERRED are supported in the CEBus protocol and play an important part in its design philosophy. Other important characteristics are data communications<sup>1</sup>, fast response, priority, and fairness.

The CEBus Architecture, which follows the ISO/OSI seven-layer network model, will be described briefly in the next chapter. The CEBus standard uses the OSI (Open Systems Interconnect) model for data communications interchange. However, it uses only four of the seven OSI layers [1], [4]. Some of the functionality associated with the Transport Layer has been built into the CEBus Network and Application Layers. The Session and the Presentation Layers of the OSI model are not required for the CEBus, so they have been omitted to minimize both packet length and device complexity.

In the literature [9] - [16], several performance evaluations of the CEBus protocol have been carried out. B. R. Bertan [9] has used a modified CSMA protocol to bound the delay for lower priority frames. Bounded delay can be achieved by increasing the access time of higher priority nodes. Pakkam and Manikopoulos [10]

---

<sup>1</sup>Provisions have been provided for the exchange of data (non control information) between CEBus devices using available bandwidth or other physical resources of the CEBus medium outside of that used for control communications.

have investigated the CEBus performance based on the Power Line (PL) by studying delay versus offered load and throughput for a number of high priority nodes. Yang and Manikopoulos [11] - [13] have studied the performance for two physical media connected with a router. However, the work considers the router as one of the three priorities. It was assumed that the data rate of the PL was 1,000 ONE b/s and that of the TP was 10,000 ONE b/s. The literature [12] and [13] contain the router as a controlled router. The philosophy behind the design of the controlled router is to limit the possibly excessive channel access by the router when demanded by high inter-network traffic originating in other medium.

Markwalter, et al., [14] have tested the CEBus proposed design by using a prototype router implemented with computer hardware. However, the priority assignment of packets utilized was limited to HIGH in order to keep channel access delays consistent.

Yang and Manikopoulos [15] - [16] have also investigated the desirable range of packet length and buffer sizes.

## 1.2 Contributions of this Dissertation

The main objectives of this dissertation are to investigate the performance of the CEBus and to formulate a theoretical analysis for it by mathematical models.

In order to evaluate the performance of the Power Line (PL) in the CEBus, a mathematical formulation has been carried out. A priority channel assigned multiple access with embedded priority resolution (PAMA/PR) has been developed which incorporates the main features of the CEBus network. Several schemes have been studied incorporating priority classes and collision avoidance in the literature. These schemes have been classified into several categories in this thesis. The scheme used in numerical analysis, i.e., PAMA/PR based on the main concept of the CSMA/CD, con-

tains prioritization (3 priorities) of the channel access, persistent channel access, and deference to higher priority class as a non-preemptive scheme. The analytic results by the mathematical model have been verified by computer simulation experiments.

In addition, the performance of the CEBus, implemented with two physical media interconnected through a router, has been investigated. The router is modeled as a node which can handle three priority levels simultaneously. The physical media employed here are the Power Line (PL) and Twisted Pair (TP) media communication lines. The delay and throughput characteristics of each of the three priority classes of messages have been measured in terms of message and channel throughputs and mean packet and total (message) delays.

Finally, an ISDN-based home information system using the CEBus has been proposed by employing *basic rate* interfaces. ISDN supplied application services for the CEBus such as home information, security, energy management, remote home control/monitoring, call management, and video telephony have been discussed. The ISDN/ CEBus network structure, data and signaling interface between the CEBus and ISDN, as well as gateway wiring have been designed. Simulation experiments have been carried out in a study of traffic through a gateway between the CEBus and the ISDN. The gateway provides 16 Kb/s for the ISDN and 10 K "1" bit/s for the home CEBus network. A study of the network sensitivity to the propagation delay between the ISDN and the CEBus has been carried out.

### 1.3 Outline of the Dissertation

Following this introduction, chapter 2 describes the architecture and protocols of the CEBus briefly in which the details can be found in the literature [1] - [6].

Chapter 3 describes the CEBus theoretical analysis. A mathematical model for the CEBus protocol is formulated. Also, numerical analyses for priority resolution

using priority channel assigned multiple access are carried out. For these analyses, embedded Markov chains and generating functions are employed. In order to evaluate throughput and delay, the expected length of cycle and the backlogs of each priority are calculated. The mathematical model does not include some aspects of the CEBus protocol such as contention resolution during the preamble field of 8 bits and queuing state in each station, which were deemed intractable in the scope of this thesis. However, the simulation experiments do include all the parts of the CEBus protocol. So the simulation work is not object to any limitations that may be present in the theoretical model. At the same time it verifies the results obtained in the mathematical model, which in turn validates the simulation model itself. The close agreement found between the analysis and the simulation results strengthens both models.

The objective of chapter 4 is to conduct simulation experiment studies for the throughput and delay performance of traffic between the Power Line (PL) and the Twisted Pair (TP) media interconnected by a router which is assigned to handle all three priority classes. The router architecture of the CEBus is layered in the same manner as a node. However, it has two Medium Access Control (MAC) Sublayers and Logical Link (Control) Sublayers using the same Network Layer. Priority based channel access enables a higher priority message to preempt a lower one while the latter is waiting for channel access.

The data rate of the CEBus for the home environment network is quite low, the Power Line (PL) and Twisted Pair (TP) each employ 10 Kb/s, which is the data rate utilized in the simulation experiments. However, generally speaking, local area networks using wire pairs can operate up to a few of Mb/s. The standard operating rate for coaxial cable is in the neighborhood of 10 Mb/s. For optical fiber, it is more than 50 Mb/s. If lasers and single-mode fibers are deployed, the range of bandwidth is far higher, in the Gb/s range. Given this low channel capacity in the CEBus, relatively large delays may be expected in comparison with other high bandwidth

networks.

In chapter 5, a CEBus gateway is designed to join the CEBus to ISDN (Integrated Services Digital Network). Such a gateway is utilized in the simulation model. A home information system may feature ISDN-based services such as remote home control, multimedia including audio, data, and video, security monitoring, and energy management. A CEBus gateway plays a key role in the successful connection of ISDN to the home. ISDN residential service can be accessed with low speed terminals, personal computers, and digital telephones through the Basic Rate Interface (BRI). For fast facsimile, and slow motion video terminals, the Primary Access Interface may be utilized. Included in the gateway capabilities is the ability to convert terminal keypress sequences into commands, and to transmit the generated commands to the appropriate media. The gateway is used to convert CEBus signals to ISDN ones and vice versa, and to provide 16 Kb/s signalling through the D-channel for the ISDN network and 10 K ONE bit/s for the home CEBus network.

# CHAPTER 2

## CEBUS ARCHITECTURE AND PROTOCOLS

### 2.1 Background

This chapter describes the architecture and protocol of the CEBus briefly as proposed in [1] - [6]. The standard also provides a comparison of supported media, a functional description of the utilized constituent layers and requirements. The details may be referred to the documents.

The CEBus is a local area network which provides a standardized communication facility for the exchange of control information among devices and services in the home. Primary consideration in the development of the CEBus is low cost and ease of operation. It addresses both of these issues by providing a standard communications interface to six supported media (power line, twisted pair, fiber optic, coaxial cable, RF, and infrared). In particular, use of the existing 60 Hz power line as a communications medium in consumer applications reduces the costs of installation of inter-room wiring between devices.

The CEBUS architecture [1] is similar to the OSI model, but has only some of the layers. Some of the functionality associated with the Transport Layer has been built into the CEBus Network and Application Layers. Since the Session and the Presentation Layers of the OSI model are not required for the CEBus, they have been omitted to minimize both packet length and device complexity.

## 2.2 Channel Access Protocol

The CEBus [1] employs three different priorities HIGH, STANDARD and DEFERRED. The state of the medium may be classified as INFERIOR or SUPERIOR [1]-[3]. For the PL control channel, the encoded symbols will be represented by the alternating presence of either SUPERIOR state phase in the message body, or alternating SUPERIOR and INFERIOR states during the preamble. Examples of encoding during the preamble portion and during the non-preamble portion of the message are shown in Fig. 2.1. To make detection of the preamble easier, the unit symbol time (UST) is longer during the preamble than during the message portion of the packet. While the unit symbol time is longer ( $114\mu\text{s}$  vs.  $100\mu\text{s}$ ), the SUPERIOR $\Theta$ 1 carrier sweep time remains constant throughout the packet. The carrier on the PL consists of a sinusoidal wave form that is swept linearly from 203 KHz to 400 KHz for 19 cycles, back to 100 KHz in one cycle, then back to 203 KHz in 5 cycles during a  $100\mu\text{sec}$  interval.

The preamble ends with a special preamble EOF symbol that divides the preamble from the non-preamble portion of the message. The following Table 2.1 is for the three CEBus encoded symbols used during the preamble. The preamble EOF consists of eight SUPERIOR $\Theta$ 1 states in a row of  $100\mu\text{s}$  each (no intervening inferior state). Then the body of the message immediately follows the preamble EOF.

During the non-preamble portion of the message, the transmitter is continually outputting a frequency swept carrier in either the SURPERIOR $\Theta$ 1 state phase or the SUPERIOR $\Theta$ 2 state phase, as shown in Fig. 2 (b).

The CEBus symbols are indicated by "1", "0", "EOF" (End of Frame), and "EOP" (End of Packet). The signal encoding for the PL control channel is Non Return to Zero (NRZ), using Pulse Width Encoding. These symbols are encoded using a swept frequency carrier coupled to the power line. For the TP, CX, or IR control channel, the SUPERIOR state is represented by the presence of either a

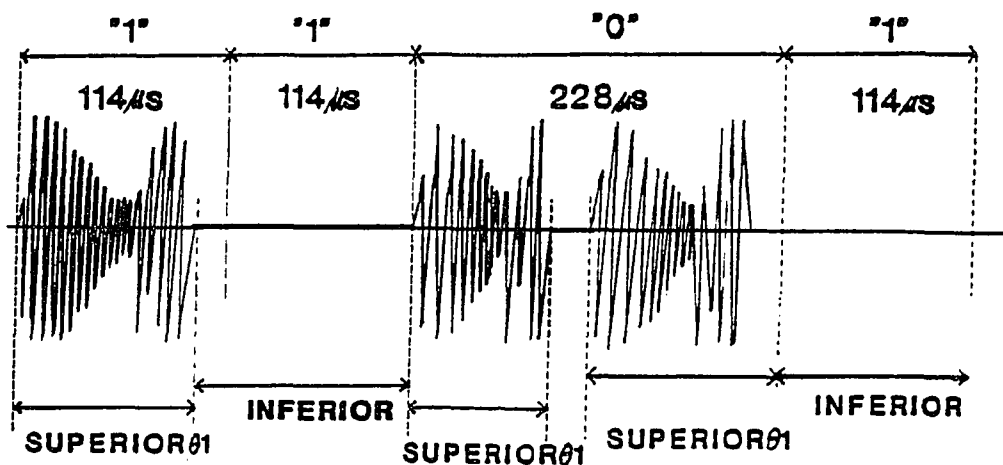

(a). Preamble Encoding Example

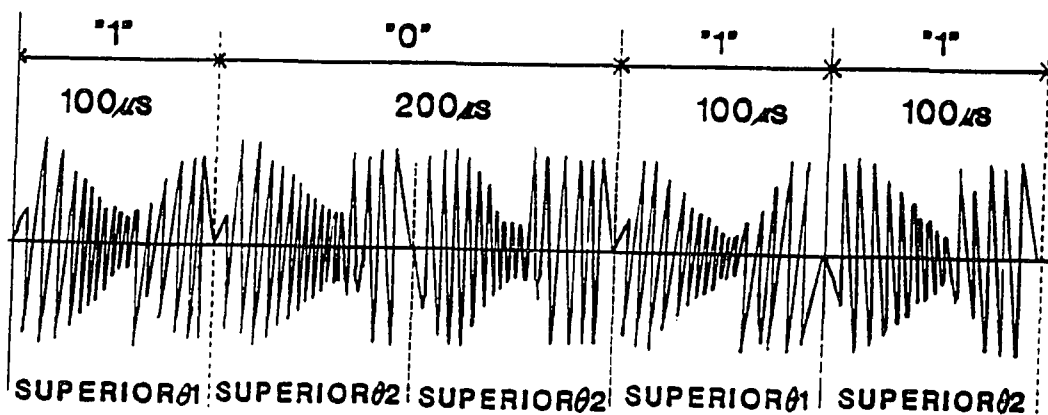

(b). Non-preamble Encoding Example

Fig. 2.1 Power Line (PL) Control Channel.



Table 2.1: Symbol Duration of the Preamble

SYMBOL	Duration	Margin
ONE	114 $\mu$ sec	$\pm 114ns$
ZERO	228 $\mu$ sec	$\pm 228ns$
Preamble EOF	800 $\mu$ sec	$\pm 800ns$

positive or a negative differential voltage, while the INFERIOR state as the absence of any voltage swing. The TP control channel occupies a bandwidth from 1 to 64 KHz. The TP signal is a differential bipolar signal making use of three levels to encode the symbols. The CX signal characteristic is Non Return to Zero (NRZ) Pulse Width Encoding (PWE). The encoded symbols will amplitude key a sinusoidal waveform carrier coupled to the coaxial cable.

In order to transmit a frame, the medium should remain in the INFERIOR state. The nodes for each priority transmit packets and wait a certain amount of time as follows:

- Successful transmission:

If the channel is sensed idle, the node may start transmission of a packet. Even if a collision occurs while the node is transmitting a SUPERIOR state, the transmitting node succeeds in completing the transmission. This procedure will be described again in item *e*.

- Unsuccessful transmission:

If the node senses the channel busy or gets involved in a collision, then it defers the transmission attempt according to a random time delay, prioritization and queueing state. The packet of the backlogged node becomes ready for retransmission again in some later slot.

To reduce the probability for unsuccessful communication, the CEBus uses several different methods to access the channel [1]-[3]. The medium channel access

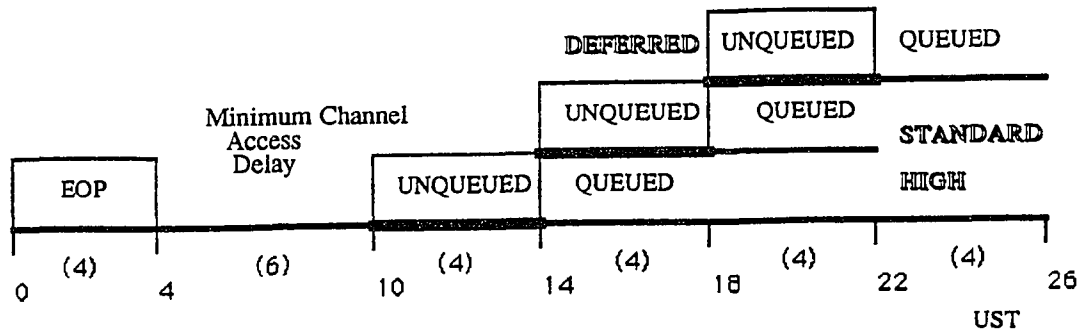

Fig. 2.2 Channel Access Wait Time of Prioritization and Queuing Scheme.

method is reviewed briefly below:

### 2.2.1 Prioritization

Fig. 2.2 illustrates the channel access wait time of prioritization and queuing scheme. According to the priority of the message and sources, the CEBus employs HIGH, STANDARD and DEFERRED priorities [1]. The lower priority nodes will always yield to the higher priority nodes and defer to them. After the end of a packet (EOP) and minimum channel access delay time, HIGH priority, imposes no additional access delay. STANDARD priority imposes 4 USTs (Unit Symbol Times) access delay, while DEFERRED requires 8 USTs access delay. This does not include the random access delay time. Therefore, higher priority frames do not have to contend for channel access with lower priority ones, as shown in Fig. 2.2.1.

### 2.2.2 Minimum Channel Access Delay (State Deference)

After a minimum of 6 unit symbol times (USTs) have elapsed following an EOP, an immediate acknowledgment (IACK) or a retransmission without conflict can take place. When the Physical layer sends an EOP (4 USTs) symbol, it readies the Data Link Layer (DLL) to transmit [1], [2].

In the case of IACK, the originating node expects to hear the beginning of the IACK preamble within the first 4 USTs after sending its EOP symbol. This sequence of events happens within the minimum wait time (6 USTs). If the originating node does not detect the beginning of an IACK within 4 USTs after the end of its frame, a retransmission will start before the 5th UST has elapsed. During this period, the originating node still owns the channel and avoids any contention. However, the receiving node must begin transmission of the IACK Preamble within 2 USTs of the end of the received originating frame. If a received IACK at the source denotes bad reception at the destination, the originating node must begin its retransmission within 5 USTs of the end of the faulty IACK.

### 2.2.3 Queueing and Round-robin Scheduling

The use of the round-robin scheme within the same priority level ensures that the contending nodes have equal opportunity to access the channel.

#### - *Queued State*

Once a transmitting node completes a transmission successfully, the node will be placed in the Queued state from an Unqueued state. The effect of being in the queued state is to repeatedly defer channel access to all unqueued nodes at the same priority level. If the queued node confirms that no other unqueued nodes attempt to send a message during the 4 UST of its queued state's delay, it may then attempt to send a message.

- *Unqueued State*

This state occurs in one of the following two circumstances:

1. If the station has no message to send or the medium is sensed idle for the maximum channel access time (22 USTs).
2. If none of the Queued nodes complete a transmission during the following 4 UST slots.

### 2.2.4 Randomization

A random delay of either 0, 1, 2, or 3 USTs is used for the control of each node's transmission start time [1], which results in reduction of contention probability during each of the priority queueing time slots. By this method, the channel throughput can be improved significantly. This randomization of start times described above is a clever and simple mechanism designed to reduce the probability of contention, which is quite successful.

### 2.2.5 Contention Detection and its Resolution

Although the above rules cover all situations and while the Data Link Layers of the nodes are designed to avoid contention over the channel, some nonzero probability of contention still exists when two or more nodes try to transmit simultaneously in the same time slot [7], [8]. Fig. 2.3 shows an example of contention detection and contention resolution.

• *Contention Detection:*

The Power Line Symbol Encoding (PLSE) sublayer provides all the necessary encoding of the CEBus symbols into the required requests for SUPERIOR or INFERIOR states on the media. So, the Physical Layer by the use of SUPERIOR and INFERIOR medium states enables contention detection. A node, while transmitting as SUPE-

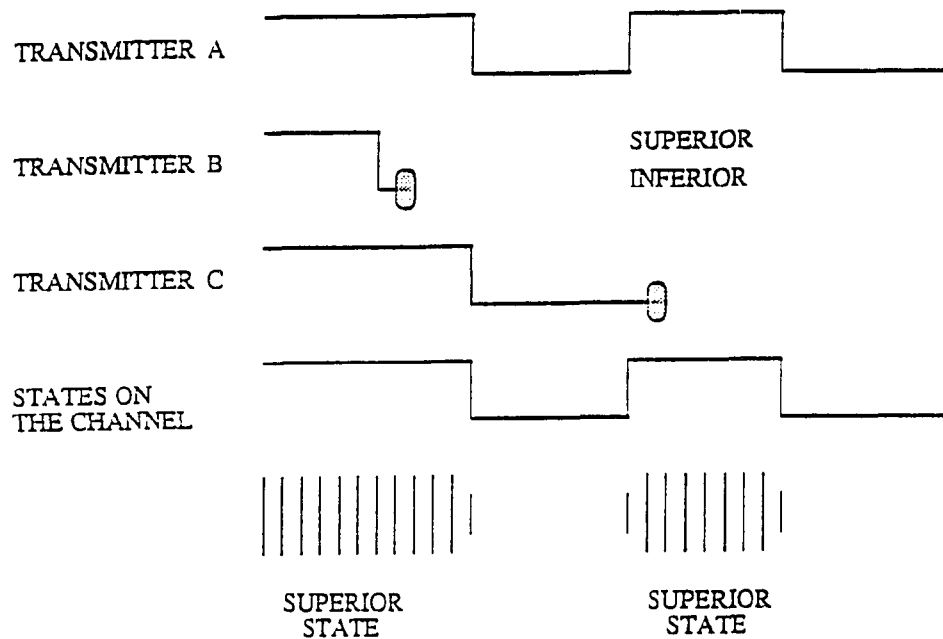

Fig. 2.3 Example of Contention Detection and Contention Resolution.

RRIOR state on the medium, will dominate any attempt to transmit an INFERIOR state by any other transmitting nodes. This dominance of the SUPERIOR state makes it possible for the nodes transmitting a SUPERIOR state to keep transmitting in preference over the INFERIOR state nodes. Fig. 2 shows an example of contention detection and contention resolution. In the CEBus, collisions occur only when two or more stations win contention during the period of preamble transmission.

- *Contention Resolution:*

The node which detects a contention while transmitting an INFERIOR state will stop transmitting immediately and continue to defer transmission until after the frame has been sent. The value of the Preamble field is a Pseudo-random bit sequence (8 pulses) which allows for contention resolution by the Data Link Layer [1]. This Preamble activates contention detection and resolution as part of the channel access protocol. For example, after two nodes have a collision, they will try to transmit their packets

by sending a random bit sequence of SUPERIOR and INFERIOR states by the Physical Layers to the medium. Of course, each node would begin its transmission in the SUPERIOR state. However, at some time, one of the colliding nodes will transmit an INFERIOR state while the other is transmitting a SUPERIOR one. The SUPERIOR state must be able to override the INFERIOR state (“listening state”), allowing a node in INFERIOR state to detect any other node’s SUPERIOR state over the medium [14], [15]. So, the conflict among the transmitting nodes can be resolved during the Preamble slot without losing any information. However, in rare occasions for some reason such as noise on the medium, device interference, or by chance, the contention may survive past the preamble. This will cause either the transmission to be aborted and retransmitted or a bad packet to be received.

### 2.2.6 Error Detection

*Cyclic Redundancy Check (CRC)* is a powerful error-detecting method. These redundancy bits do not carry any information; they are merely used to determine the correctness of the bits carrying the information.

Here, all the characters in a message block are treated as a serial string of bits representing a binary number. This number is then divided modulo 2 by a predetermined binary number and the remainder of this division is appended to the block of characters as a cyclic redundancy check (CRC) character. The CRC is compared with the check character obtained in similar fashion at the receiving end. If they agree, the message is assumed correct. If they disagree, the receiving terminal will demand a retransmission. This is usually called the ARQ (Automatic Repeat Request) method of error control and is very commonly used in data communication. The CRC character is also called the cyclic check sum, or simply the check sum character.

The Power Line protocol employs “error detection” performed at the Sym-

bol Encoding sublayer level, i.e. PLSE (Power Line Symbol Encoding Sublayer). For error correction, the status service primitive, PH\_CC\_STATUS, indicate (e.g., GOOD\_FRAME or BAD\_FRAME) is passed up at the end of every received packet (at the end of CRC) [4]. That is, the Frame check Sequence (FCS) is computed over the Unit Symbol Times(UST) by treating  $\Theta_1$  as logical 1s and  $\Theta_2$  as logical 0s. Here one phase is called  $\Theta_1$ , and the opposite phase is called  $\Theta_2$  from either SUPERIOR  $\Theta_1$  or SUPERIOR  $\Theta_2$ . For reference, the PREAMBLE EOF and the rest of the frame are encoded by state changes between one of two phases of an elemental waveform. Media that do not use Symbol Encoding Sublayer error detection do not have this primitive value. The specific Frame check sequence used is a 16-bit CRC standard, known as  $1 + X^2 + X^{15} + X^{16}$  [4].

Bits are shifted into the CRC computation starting with the  $\Theta_2$  UST that must follow the PREAMBLE EOF. The PREAMBLE EOF will always be transmitted as 8  $\Theta_1$  pulses. A 0 is the first bit into the CRC computation. Each transmitted UST ( $\Theta_1$  or  $\Theta_2$  pulse) shifts another bit into the CRC. This process, as explained in [4], continues until the last of 4 EOP USTs is processed. At this time the CRC will contain the 16bits that will result in a 0 in the CRC register.

At the end of the EOP, the PLSE immediately transmits the 16 USTs encoding the 16 CRC bits. The most significant bit of the CRC16 is transmitted first. A PL medium will always end with four EOP USTs plus 16 CRC USTs. After handling of USTs and error checking, the CRC is cleared and each UST after the PREAMBLE EOF shifts a new bit to the CRC computation. After the last UST, an error free frame will result in 0 in the 16 bits of the CRC.

# CHAPTER 3

## CEBUS THEORETICAL ANALYSIS

### 3.1 General

One characteristic of a local area network is that all attached users (or stations) on its medium may attempt simultaneously to gain access to the transmission facilities. Gold and Franta [21] have categorized multi-access protocols, based on two general criteria (a) the level of node cooperation demanded by the protocol along with the information the nodes employ and (b) the degree to which they adapt to changes in demand for the channel, as follows:

- 1) Fixed Assignment
- 2) Random Assignment
- 3) Demand Assignment

One of the most widely used random access protocols is Carrier Sense Multiple Access with Collision Detection (CSMA/CD). This provides excellent channel utilization and low packet delays under light traffic loads. However, in order to provide a priority function in the channel access recently prioritized channel access mechanisms have been considered. According to the type of the packets transmitted such as data files, e-mail, interactive data, remote control, emergency reporting and system management, different delay times and throughputs are required.



In order to resolve collisions, several schemes have been studied for incorporating priority classes and collision avoidance. Those schemes proposed in the literature can be classified into several categories, on the basis of the objectives and approach methods, as follows:

### A. Priority Queueing Approach

In the priority queueing scheme at station buffers, each station organizes a priority queue with Head-of-Line (HOL) discipline. Accordingly, the packet at the head of the buffer will be the longest-waiting packet of the highest priority class, at any instant. A new arrival packet to the buffer, with greater than the current highest priority, will displace the packet currently at the head of the queue.

- *Preemptive/Non-preemptive Priority Queueing;*

Priority Queues (preemptive or non-preemptive) [51], and CSMA/CD-P [52] are examples of such a priority queueing scheme. In the *Preemptive Priority Queueing System* [53], two-classes of customers were considered. The high priority class has preemptive head of the line priority over the low priority customers. In Non-preemptive Priority Queueing System [53], [54], the preemption is not allowed. In order to compute the state probabilities in priority queueing systems, the recursive formulas as well as the generating function of the number of customers in the system are derived.

- *Prioritized Virtual Time CSMA (PVT-CSMA);*

In PVT-CSMA [55], the packets in the network arrive with a priority queueing mechanism, following the head-of-line principle. The higher priority transmits packets ahead of the lower priority. Within a priority class, the packets must be transmitted in the order that they were received.

### B. Reservation-based Priority

This scheme employs a channel reservation by allowing a portion of the channel

bandwidth at the end of a transmission. Priority-Ethernet [56], Modified CSMA/CD with MP [57], and DAMA [58] all follow this scheme. CSMA with message-based priority [59] allows reservation of the channel partitioned into two blocks: first, the high priority class messages at the end of a transmission contend for the channel access. Second, the users with messages of lower priority are inhibited from attempting channel access if a higher priority message is waiting to be transmitted. Noel Gonzalez-Cawley and F.A. Tobagi [60] have formulated a message-based priority function in non-preemptive Priority-CSMA, the semi-preemptive and fully-preemptive P-CSMA.

- *Ordered-Access Bus Approach*

As an example of a bus system employing ordered access, we can consider the reservation-type scheme MLMA (multilevel multiple access) proposed by Rothauer and Wild [61]. In the MLMA, each station attached to the bus owns one bit within the request slot. By setting its private bit, a station indicates that it wants to transmit a packet within this frame. At the end the request cycle, all stations know which of the stations will use this frame. Packets from all stations form the distributed queue  $Q_0$ . At this point, all packets within  $Q_0$  simultaneously obtain a scheduling time (batch service), in which the scheduling time  $T_s$  may have to be significantly longer than the pure transmission time of the request slot. As a result, the transmission sequence is given by a priority assignment known to all stations. The MLMA method is similar in concept to a bus access which has been analyzed by Mark [62], and to a contention resolution method for computer-interrupt systems proposed by Taub [63].

### C. Conflict-Free Approach

In contrast to contention protocols such as ALOHA [22]-[27], CSMA [26]-[33] and CSMA/CD [36]-[45], medium access in conflict-free protocols is granted to exactly one user at a time. The Controlled Token, Time-Division Multiple Access (TDMA), Frequency-Division Multiple Access (FDMA) [80], [19] Distributed Scheduling Mul-

multiple Access [66] and Mini-slotted Alternating Priorities [67] belong to the category of the conflict-free protocols. The controlled token scheme with separate token cycle will be described in case E.

The CEBus protocol [1] makes use of this scheme for channel assignment of different priority. The CEBus also employs a conflict-free scheme by using the SUPERIOR state deference during the preamble bits.

Similarly, the collision problem may also be solved with hardware by using a collision avoidance switch, as described in the next section.

#### **D. Node Partitioning Approach**

The NP-CSMA [65] approach establishes a threshold priority level at the end of each successful transmission. The packets of greater priority may contend for the channel at the next idle slot, whereas ready users with packets of priority less than the threshold are inhibited from contention until the greater priority users are idle or empty. In this mechanism, the set of ready users is partitioned into two blocks: one for contending channel access, and the other for being inhibited from contention.

#### **E. Parametric and Separate Token Cycle Approach**

This approach employs a different set of access parameters to provide each priority. P-CSMA based on staggered delays [69], retransmission delay [43], and P-Dynamic CSMA/CD [70] have no strict partitioning as in the other overhead due to reservation. Separate token cycle approach can be found in Karvelas [32] which utilized separate token cycles to provide access to different traffic classes, high (voice) and low (data).

#### **F. Collision Avoidance Switch Approach**

This approach uses hardware implemented collision avoidance switches to prevent collisions by arbitrating random access to a communication channel. Broadcast

star network has been studied by Albanese [71], Lee and Boulton [72], Suda, Yemini and Schwartz [73] and Morris and Niguyen [74], Y. Yemini [75] and T. Suda and K. Gota [76]. For example, each station is connected to a central switch by a full duplex channel comprising an uplink and a downlink. The switch may be viewed functionally as containing two components: the selector for uplinks from stations and the broadcaster for downlinks to stations. Murata and Takagi [84] proposed priority queueing systems with  $p$  classes of messages. In the first, the class of message to be served next is the highest priority class existing at the beginning of the current service. It was assumed that the message service time distribution and the switchover time distribution are identical for all classes. In the second model, the next service is scheduled at the end of the current service. In the third discipline, the next service is given to the highest priority class at the end of the switchover time, and its service is immediately started.

### G. Hyperchannel Interface Access Approach

Hyperchannel interfaces [79] are designed to provide for message-assigned priorities. The extension requires little additional new hardware but instead employs a replication in each interface of existing hardware. The hyperchannel BIU<sup>1</sup> protocol is characterized as:

- giving priority to BIU sending ACK or NAK messages.
- providing distributed access control so that nodes can be easily added or deleted from the network.
- avoiding single points of failure.
- being responsive to the burst transmission needs of network nodes.
- mitigating the differences in speed between connected nodes.

---

<sup>1</sup>Devices known as Bus Interface Units (BIU) or network adapters. The BIU basic structure is composed of Bus Access interface, Interface logic and Device interface.

- providing priority access control for BIUs wishing to transmit.

The hyperchannel BIU design provides four features; transmitter disabled, fixed delay, unique time slot delay and contention.

#### H. Timer Controlled Random Access Approach

The high-speed local network (HSLN) is designed to provide high end-to-end throughput between high-speed (50 Mbps) devices, such as mainframes and mass storage devices including bulk data transfer and automatic back up, with a limited number of devices (10-20) over a relatively small distance (less than 1 km) [80].

This scheme can be described in terms of the ANSI (American National Standards Institute) draft standard [81]; the algorithm for HYPERchannel is very similar. The protocol follows an ordered logical sequence (PORT(1), PORT(2), ..., PORT(N)), which need not correspond to the physical state of the medium. Following initialization PORT(I+1) waits until after PORT(I) has had a chance to transmit. The wait time consists of

- (a) the earliest time at which PORT(I) could begin transmitting (which depends on the transmission opportunity for PORT(I-1)), plus
- (b) a port delay time during which PORT(I) has the opportunity to transmit, plus
- (c) the propagation delay between the two ports.

The timers which reach a specified maximum value are said to have expired. They are composed of the priority access timer, arbitrated access timer and resynchronization timer. Many parts of this technique seem well suited to the CEBus scheme.

Among the priority functions and collision avoidance [55]-[82], the analysis approach of this thesis is similar to those followed in [40], [45], and [68]. In summary, PAMA/PR methodology of this dissertation employs *a)* priority channel assignment for partitioning channel access on the network, *b)* embedded priority reservation at

the EOP (End of Packet), *c*) random start time delay within the same priority class, *d*) minimum channel access time, and *e*) round-robin scheme for fairness of access within the same priority class.

In order to analyze the message interdeparture time, message delay and system states, one will make use of the moment generating functions (MGF). The MGF processes were studied in [36] for non-persistent CSMA/CD with the delayed first transmission operation under the unslotted scheme. They were also studied for CSMA and CSMA/CD for the persistent and non-persistent operations [44], [64]. In [59], they are used for CSMA with message-based priority functions.

In deriving the MGF, the transition probabilities, the probability mass function of the embedded slots and the steady state probabilities are applied, as obtained in section 2.

## **3.2 Priority Channel Assigned Multiple Access with Embedded Priority Reservation**

### **3.2.1 Analysis Methodology and Algorithm**

The CEBus channel access scheme is designed to minimize the probability of conflicting transmissions. The primary methodology [1] is composed of 4 steps as follows:

1. Prioritization of the channel access
2. Randomization of start time delay interval within each priority and queueing state
3. Round-robin queueing state to ensure equal (fair) access within a priority level
4. Deference to other channel traffic (SUPERIOR state deference)

For simplicity in the analysis of the CEBus protocol, several assumptions have been made for priority channel assigned multiple access with embedded priority reservation and resolution (PAMA/PR) as follows:

- slotted axis. The channel axis is slotted, with the slot size equal to  $1UST$ . Here  $1UST$  stands for unit symbol time (ONE) and represents the time needed to transmit the shortest symbol. The ZERO symbol requires two USTs. Therefore in order to transmit 1 bit, which is equally likely to be ONE or ZERO, it actually takes an average 1.5 USTs, i.e., 1.5 slots through the MAC layer. However, for simplicity in the analysis, it is assumed to take 1 slot to transmit 1 bit length (actual values may be calculated by multiplying 1.5 times the results of the numerical analysis). Here the effect of  $\xi$  and  $\zeta$  is neglected<sup>2</sup>, where  $\xi$  denotes the time it takes a station to detect interference once the interference reaches the station,  $\zeta$  denotes the time period used for collision reenforcement, and  $\tau$  is the propagation delay. However, these parameters including  $\tau$  are assumed to be less than 1 slot time.
- Synchronization to the same time axis. All stations are synchronized to a universal time axis. They transmit messages only at slot boundaries.
- Finite size of the population and a single buffer at each station. An idle user may generate a message in a slot with probability  $g_p$  (and does not with probability  $1 - g_p$ ), where  $p$  refers to one of the three priorities and  $0 < g_p < 1$ . We call this a geometric arrival process. An arriving message that finds the buffer fully occupied is lost. A backlogged user or station will reschedule its transmission according to a geometric process with probability  $\nu_p$ . A single buffer at each station is assumed because models with larger buffer structures are very difficult to analyze.

---

<sup>2</sup>The detailed meaning  $\xi$ ,  $\zeta$ , and  $\tau$  are described in [45] with figures.

- persistent protocol. In order to randomize the start of transmission during channel access delay for each priority, the persistent protocol is adopted. It is activated following the beginning of the priority channel assignment at which the channel goes idle. When the channel is sensed busy, the station monitors the channel, i.e., it persists until the channel becomes idle, and then
  1. it initiates transmission of the message with probability  $\nu_p$ .
  2. It defers transmission by  $1UST$  with probability  $1 - \nu_p$ . If the channel is sensed idle after a time delay, the station repeats step 1 and 2, otherwise, it schedules retransmission of the message to some later time.
- All messages of each priority are assumed to be of constant length.

At any observation instant, a user may be in one of two states; (a) *thinking* state if it does not have a message to transmit, and (b) *backlogged* if it has a message awaiting or it is undertaking transmission. In this scheme, the rescheduling delay of a backlogged message, as noted in [40], [76], is assumed to be geometrically distributed with mean  $1/\nu$  slots. In other words, a backlogged station senses the channel and, if idle, transmits in the current slot with the probability  $\nu$ .

If a collision is detected during transmission, the station aborts the transmission and schedules its message for retransmission. In a collision case, a minimum transmission duration called the collision detection interval,  $T_{cp}$ , is required. A possible collision is resolved by the priority channel assignment scheme.

For the sake of simplicity and without loss of generality, the state of the user, i.e., queued state or unqueued state, is assumed to be fixed as one of the two states. However, in the steady state the delay performance is predominately affected by the priority of the message, i.e., the priority access delay assignment. In Fig. 3.1 the *priority contention resolution* and *embedded slots in slotted persistent priority* are illustrated.



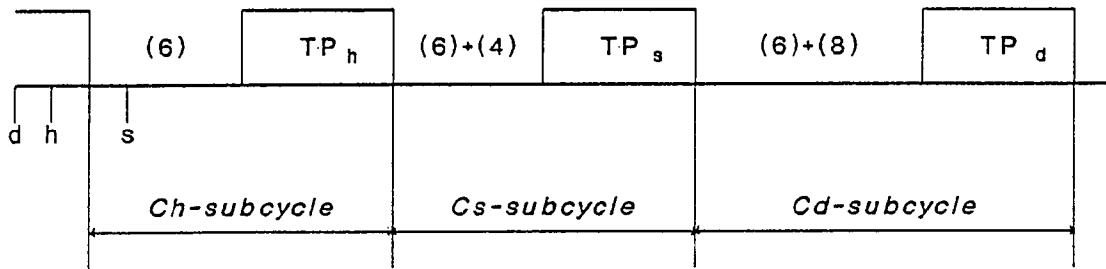

(a) Example of the priority contention resolution

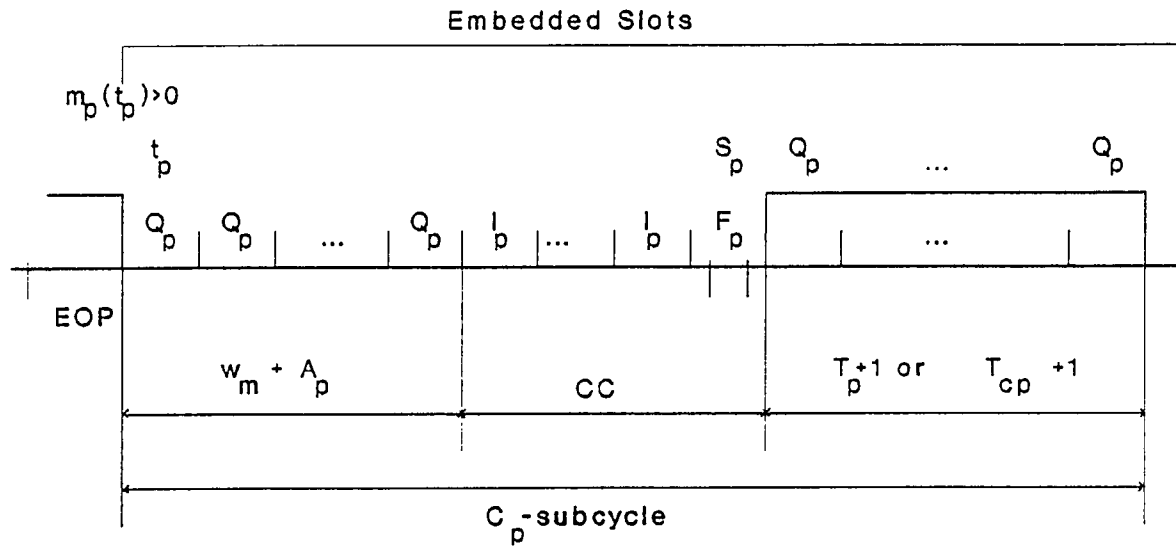

$A_p$ : Priority Channel Access Delay Time  
 $CC$ : Channel Contention Period  
 $TP$ : Transmission Period  
 $T_{p+1}$ : Successful Transmission  
 $T_{cp+1}$ : Unsuccessful Transmission

(b) Embedded Slots in Slotted Persistent Priority

Fig. 3.1 Priority Resolution and Embedded Slots.

So, the CEBus performance is analyzed by this simplified queueing state without losing the broad picture of the overall performance. The limitations which may be present in the analysis do not exist in the simulation experiments of the scheme, as shown in the results. The difficulty in analyzing the CEBus scheme arises from the fact that the system's service is dependent on the system's evolution in time in terms of the activity of the users and the mix of the priorities in the messages. The time required to transmit a message is a function of the number of contending users and the accumulated higher priority messages during the lifetime of the current message. As the profile of users and messages evolves performance changes. This prevents us from using conventional queueing techniques directly, without modifications. The techniques and results appearing in the literature [25], [45], [59] have been adapted to handle transition probabilities for the CEBus. In order to find the expected delay lengths of three priorities and the expected size of each priority's backlogs, Tobagi's Message-Based Priority Functions (MBPF) [59] have been recast to employ the CEBus's three priorities. Tobagi's model differs from this analysis primarily in the following items:

1. The CEBus scheme supports 3 instead of 2 priorities.
2. In the MBPF, following EOC (End of Carrier), if the carrier is detected in the first reservation slot, the access right is given to class  $i$ , and then the user transmits a packet over the channel access period (CAP). However, in the CEBus, following EOP, if there is a higher priority station contending, the access right will be granted to the higher priority. But it must wait for a minimum waiting time ( $w_m$ ), and then transmit a packet during its priority channel access (PCA) period.
3. In the MBPF if no carrier is detected prior to the  $j$ th (here 2nd) reservation-slot, where  $j = \nu(h)$ , then user  $h$  transmits a short burst of unmodulated carrier

of duration  $\gamma$  at the beginning of reservation-slot  $j$ , and utilizes the channel immediately following this reservation-slot. However, in PAMA/PR the users must wait up to  $w_m$  and then contend for channel access, according to their priority during the PCA period. Therefore, users between different priority classes cannot have a chance to collide.

4. Following EOC in the MBPF, if no carrier is reserved and there are two or more users they will have a collision, regardless of priority. In PAMA/PR, following an EOP, if no carrier is reserved, even if there are three users but of different priority, they will have no collision. Also, in PAMA/PR, even if there is only one higher priority arrival in the midst of many lower priority arrivals, the higher one wins and does not contend with those of lower priority.

In this analysis, the performance depends on the nature of the embedded Markov chain processes, the regenerative process, the delay-cycle analysis and the priority channel access assigned delay.

### Algorithm

The Priority Channel Assigned Multiple Access with Priority Resolution algorithm (PAMA/PR) is used for the CEBus. It operates as follows;

1. Initialize.
2. Generate messages.
3. Monitor the channel state to determine whether there is a backlogged user or not, at the end of EOP. If there is no priority reservation, or no backlogged user,  
then go to step 4,  
else go to step 8.

4. Contend for channel access.
  - (a) if the message is of High priority, then go to step 5,
  - (b) if Standard priority, then go to step 6,
  - (c) if Deferred priority, then go to step 7.
  
5. Wait a minimum wait time (6 slots) plus 0 high priority access delay time, then initiate transmission of the message with probability  $\nu_h$ . The *various situations in high priority transmission* procedure are shown in Fig. 3.2.
  - (a). If a collision is detected then the transmission aborts after a collision recovery time,  $T_{ch}$ . Then, repeat steps 3-8 to be retransmitted.
  - (b). Else, the transmission proceeds.
  
6. Wait a minimum wait time of 6 slots plus 4 slots standard priority access delay time, then initiate transmission of the message with probability  $\nu_s$ . The *time sequence of events for standard priority message transmission* is depicted in Fig. 3.3. The remaining steps are the same as Step 5.(a) and 5.(b).
  
7. Wait a minimum wait time of 6 slots plus 8 slots deferred priority access delay time, then initiate transmission of the message with probability  $\nu_d$ . The rest of the steps are the same as Steps 5.(a) and 5.(b).
  
8. When the channel is sensed busy, then the user awaits the EOP signal mark. If the backlogged message is of high priority, then go to step 5. If standard priority, go to step 6. If deferred priority, go to step 7. Following the end of EOP, the higher priority message gains the access right. If at the end of EOP there is no high and/or standard priority, then the back-

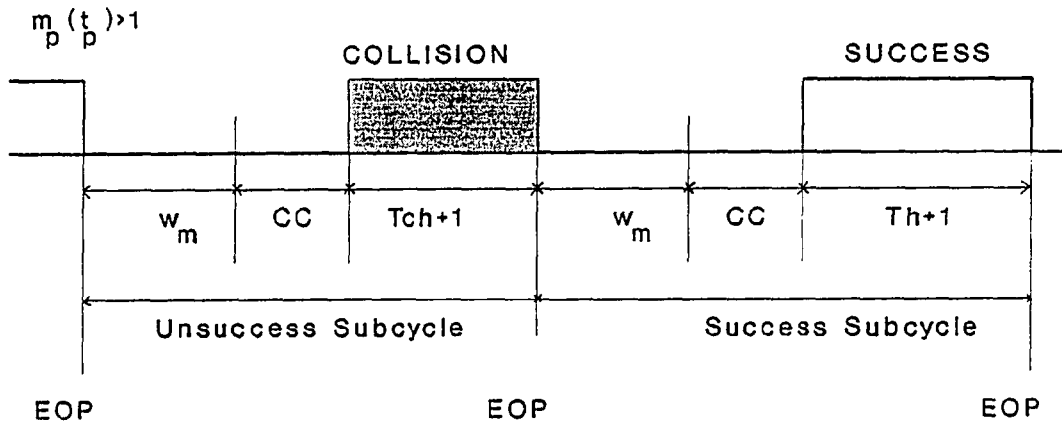

(a) Backlogged Users at the Beginning of the Embedded Point

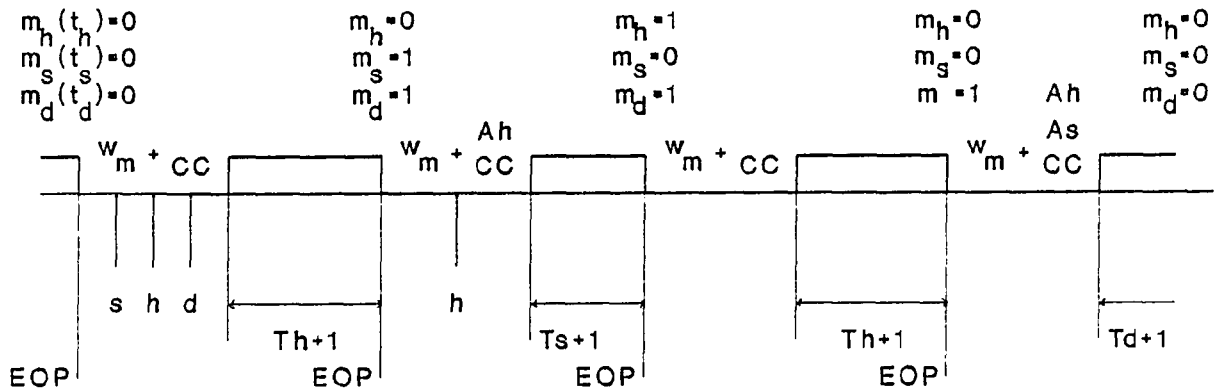

(b) Empty Backlogs at the beginning of the Embedded Point

Fig. 3.2 The Various Situations in High Priority Transmission.

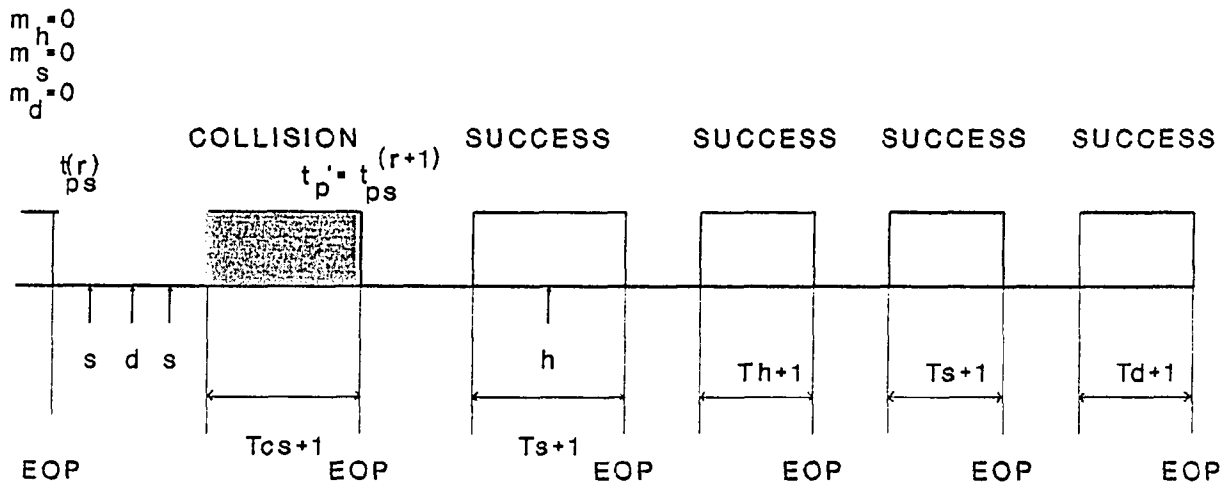
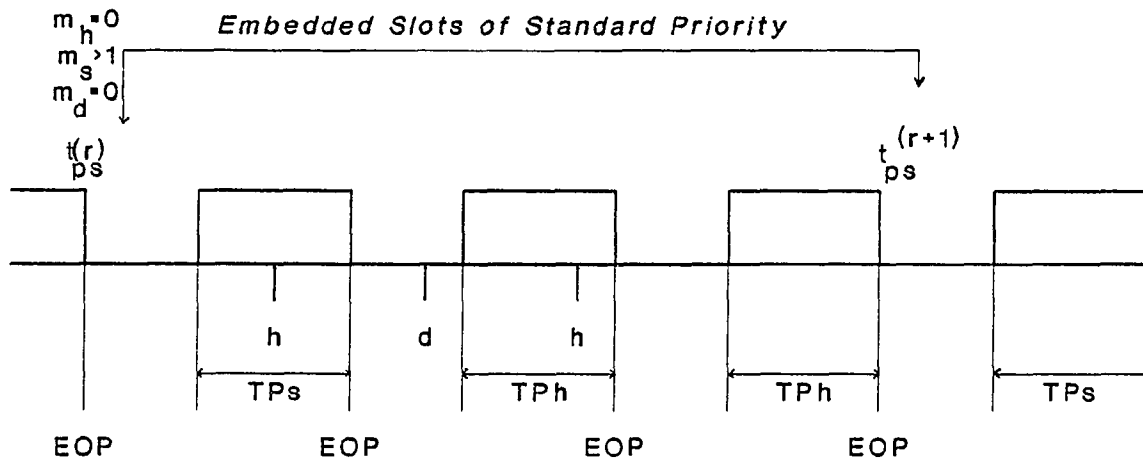

**Fig. 3.3** Time Sequence of Events for Standard Priority Message Transmission.

logged deferred priority message will reserve the channel access, as shown in Fig. 4.4.(a). The complete *time sequence of events for the deferred priority message transmission* is depicted in Fig. 3.4.

In this nonpreemptive priority, when a higher priority message arrives during the waiting time, the higher priority is not granted access right until the next EOP, at which time it regains the access right.

### 9. Exit.

At the end of EOP, if there is no backlogged user of the higher priority, but there is a backlogged user of the lower priority, then the latter reserves the channel, and channel access is given to the reserved lower priority. During the waiting time, even if some other higher priority user generates a new message, this priority cannot preempt the lower priority message which already reserved the channel access right at the end of transmission. This higher priority will regain the channel access right to transmit, but only following the next EOP.

If, following EOP, no priority reservation or no new arrival message over the minimum wait time plus priority channel access delay time,  $(w_m + A_h + A_s + A_d)$  occurs, all users regardless of their priority can access the channel freely until a new EOP is detected.

## 3.2.2 Transition Matrices

### One Step Transition Matrices for Processes of 3 Priorities

To analyze the system state, a two-dimensional embedded Markov chain process model is used for the transition matrix  $P$ .

One dimension of the model is the number of backlogged users,  $i$ , and the other dimension is the number of ready users,  $j$ . Here ready user means all users who are

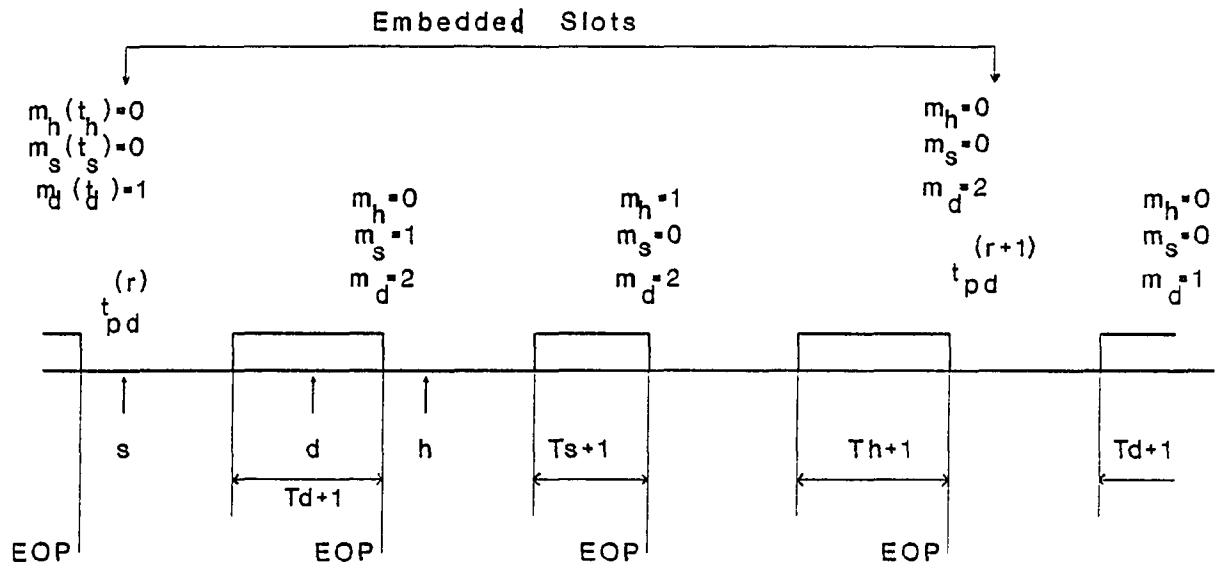

(a) Backlogged Users at the Beginning of the Embedded Point

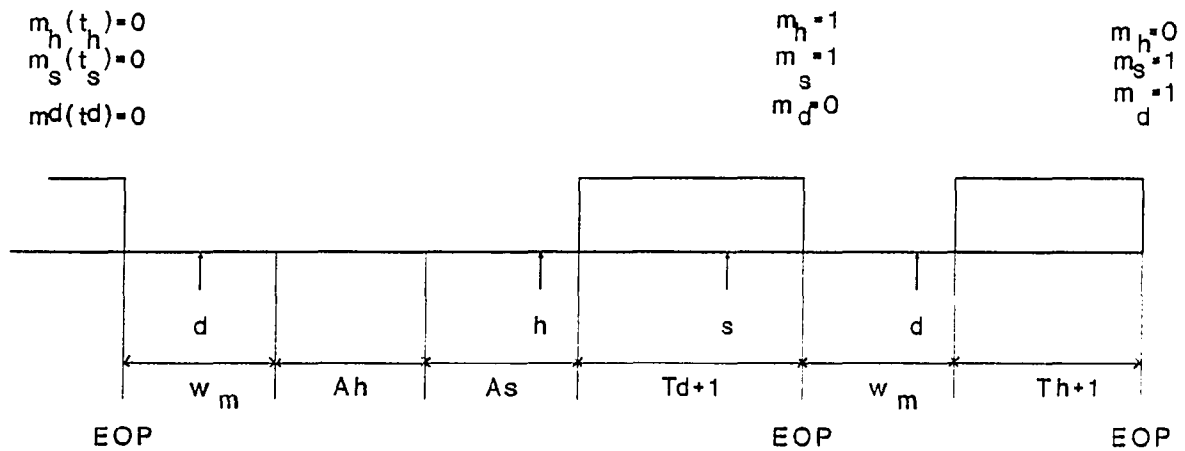

(b) Empty Backlogs at the beginning of the Embedded Point

Fig. 3.4 Time Sequence of Events for Deferred Priority Message Transmission.



attempting transmission from an already backlogged buffer and new arrival users who join the backlogged state when the channel is idle or ready to transmit. Thus the state of the system is given by  $(i, j)$ . This state is defined at embedded points as

1. the end of a successful transmission, or
2. the end of a collision,
3. a transition point from an initial state of the system  $m(t_e) = i$ , to a final state at the start of the corresponding transmission period,  $m(t_e + 1) = k$ . Here  $k - i$  new users have joined the backlog in the last slot of the idle period.

Case 3 is an embedded point in the narrow sense. In case 1 and 2, the channel is sensed idle by all users one slot after the end of transmission by the station transmitting last. This means that the length of the successful and collision transmission intervals are  $T_h + 1$  and  $T_{ch} + 1$  slots, respectively.

The matrix  $\mathbf{P}$  is the product of all previously considered single-slot transition matrices in a cycle. Therefore, the transition matrix element at two embedded slots  $[P_p]_{i,k}$  can be expressed by

$$[P_p]_{i,k} = P_r \{m_p(t_p^{(r+1)}) = k | m_p(t_p^{(r)}) = i\}$$

The subscript  $p$  represents the 3 priorities,  $h$  for High,  $s$  Standard and  $d$  Deferred priority, respectively. The symbol  $t_p$  indicates the time of end of carrier, i.e., EOP (End of Packet).

Since the length of the busy period depends on the number of users which become ready in slot  $t_p + I - 1$ , the  $r$ -step transition probability matrix over the busy period following the analysis presented in [45], [68], can be expressed as

$$s_{i,j} = Pr\{m_{t_p+I} = j \text{ \& Successful Transmission } | m_{t_p+I-1} = i\} \quad (3.1)$$

$$f_{i,j} = Pr\{m_{t_p+I} = j \text{ \& Unsuccessful Transmission } | m_{t_p+I-1} = i\} \quad (3.2)$$

Let us define  $a_i^{(p)}(k)$ ,  $b_i^{(p)}(k)$  and  $d_i$ , respectively as follows:

$a_i^{(p)}(k)$  = probability that  $k$  users in the thinking state transmit in a slot when the backlogged user is  $i$ , within priority  $p$

$b_i^{(p)}(k)$  = probability that  $k$  backlogged users transmit in a slot when the backlogged user is  $i$ , within priority  $p$

$d_i$  = probability of having no users transmitting in a slot when the backlog is  $i$ ,

where

$$a_i^{(p)}(k) = \binom{M_p - i}{k} g_p^k (1 - g_p)^{M_p - i - k} \quad (3.3)$$

$$b_i^{(p)}(k) = \binom{i}{k} \nu_p^k (1 - \nu_p)^{i - k} \quad (3.4)$$

$$d_i^{(p)} = a_i^{(p)}(0) b_i^{(p)}(0) \quad (3.5)$$

It is assumed that the arrival rate  $g_p$  of each of  $M - i$  users in a slot with priority  $p$  is geometrically distributed. The parameters are defined as

$T$	=	number of time slots
$M$	=	number of the total users
$i$	=	number of backlogged users at the beginning of transmission
$k$	=	number of backlogged users at the end of transmission
$k - i$	=	number of new arrivals
$M - k$	=	number of idle users at the end of transmission
$g_p$	=	new arrival rate per user with priority $p$
$\nu_p$	=	probability that the terminal transmits the packet (implying probability $(1 - \nu_p)$ the terminal delays the transmission)

Here, as previously mentioned,  $p$  as a subscript or a superscript in a parameter denotes its priority. During the minimum wait time, the priority channel access delay, and the transmission period, all new arrivals join the backlog. A new arrival sensing the channel idle may transmit with probability one. Therefore, the  $(i, k)$ th element of

matrix  $\mathbf{S}$  for the transition probability from state  $i$  to state  $k$  is given as

$$[S_p]_{i,k} = \begin{cases} 0 & k < i \\ \frac{\alpha_i^{(p)}(0)b_i^{(p)}(1)}{1 - d_i^{(p)}} & k = i \\ \frac{\alpha_i^{(p)}(1)b_i^{(p)}(0)}{1 - d_i^{(p)}} & k = i + 1 \\ 0 & k > i + 1 \end{cases} \quad (3.6)$$

where the probability that no user becomes ready during slot  $t$  is given by  $d_i = (1 - \nu)^i(1 - g)^{M-i}$ , given  $m_p(t) = i$ . The probability that one or more becomes ready during slot  $t$  is equal to  $1 - d_i$ . The average length of the idle period is found to be given by

$$\begin{aligned} \bar{I}_i^{(p)} &= \frac{1}{1 - d_i^{(p)}} \\ &= \frac{1}{1 - (1 - \nu_p)^i(1 - g_p)^{M_p-i}} \end{aligned} \quad (3.7)$$

where  $p$  again denotes  $h$  (High),  $s$  (Standard) and  $d$  (Deferred) priorities.

The matrix  $\mathbf{Q}$  represents the increase in backlog due to some of the thinking stations becoming backlogged on finding the channel busy. During the minimum wait, priority channel access delay, and transmission period, all new arrivals join the backlog. This is a simple Bernoulli type arrival process. Fig. 3.5 shows the arrival transition during the minimum wait and priority channel access delay time, where  $a(\cdot)$ ,  $b(\cdot)$ , and  $c(\cdot)$  are defined in Eq. (3.16) - (3.18). Therefore, the arrival transition probabilities are given by

$$[Q_p]_{i,k} = \begin{cases} 0 & k < i \\ \alpha_i^{(p)}(k - i) & k \geq i \end{cases} \quad (3.8)$$

Let  $Q_p^T$  be the probability that we have  $k - i$  new arrivals among  $M - i$  users in  $T$  slots. Using the geometric arrival rate  $g_p$  for each of  $M - i$  users in a slot, the probability matrix element may be written as

$$[Q_p^T]_{i,k} = \binom{M_p - i}{k - i} \{1 - (1 - g_p)^T\}^{k-i} (1 - g_p)^{T(M_p - k)} \quad k \geq i \quad (3.9)$$

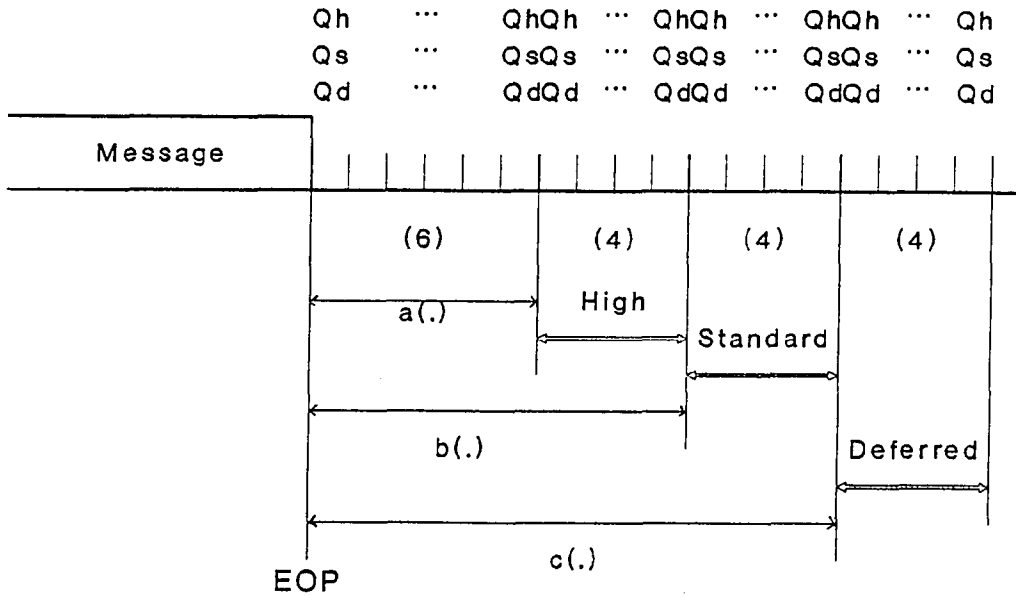

**Fig. 3.5** Arrival Transition during the Minimum Wait and Priority Channel Access Delay Time.

Note that for  $k < i$ ,  $[Q_p^T]_{i,k} = 0$ .

**F** is the transition probability matrix from state  $i$  to  $k$  with unsuccessful transmission. The elements of **F** are given by

$$[F_p]_{i,k} = \begin{cases} 0 & k < i \\ \frac{a_i^{(p)}(0)[1 - b_i^{(p)}(0) - b_i^{(p)}(1)]}{1 - d_i^{(p)}} & k=i \\ \frac{a_i^{(p)}(1)[1 - b_i^{(p)}(0)]}{1 - d_i^{(p)}} & k=i+1 \\ \frac{a_i^{(p)}(k-i)}{1 - d_i^{(p)}} & k > i+1 \end{cases} \quad (3.10)$$

**J** represents the decrease in backlog after a successful transmission at the instant the backlogged station reenters the thinking mode. The elements of matrix **J** are 0 except when  $k = i - 1$  when they are 1. Therefore, the elements of the departure matrix  $J_p$  are given by

$$[J_p]_{i,k} = \begin{cases} 1 & k = i - 1 \\ 0 & \text{otherwise} \end{cases} \quad (3.11)$$

Here  $M$ ,  $\sigma$ , and  $\nu$  are assumed to be time-invariant as in [40], [45], and [46].

### Derivation of the Transition Matrix $P_h$

The transition probability matrices denoted by  $\mathbf{P}$  between consecutive observation points can be computed from one-slot transition matrices  $\mathbf{S}$ ,  $\mathbf{Q}$ ,  $\mathbf{F}$ , and  $\mathbf{J}$ , in a similar manner to [25], [45] and [68]. An example of the embedded Markov chain model is also found in [47].

Given that  $i_h = m_h(t_{ph}^{(r)})$ , the probability that  $m_h(t_{ph}^{(r)} + w_m) = i'$  is simply  $[Q_h^{w_m}]_{i_h, i'}$ . According to the above methodology, the transition matrices are written for 2 cases as follows:

**Case 1.**  $i_h = m_h(t_p) \neq 0$

$$\begin{aligned} [P_h]_{i_h, k} &= P_r \{ m_h(t_{ph}^{(r+1)}) = k | m_h(t_{ph}^{(r)}) = i_h \} \\ &= \sum_{i'=i_h}^{k+1} [Q_h^{w_m}]_{i_h, i'} [S_h Q_h^{T_h+1} J_h]_{i', k} \\ &\quad + \sum_{i'=i_h}^k [Q_h^{w_m}]_{i_h, i'} [F_h Q_h^{T_{ch}+1}]_{i', k} \end{aligned} \quad (3.12)$$

Here,  $m_p(t_p)$  is the number of the backlogged stations at time  $t_p$ , and  $T_h + 1$  refers to the length of the successful transmission. The additional slot accounts for the propagation delay since the channel axis is slotted. If the transmission of the message is unsuccessful, then the transmission period  $TP_h$  becomes  $T_{ch} + 1$ . Actually, the collision recovery time,  $T_{cp}$  slots, is defined as the time elapsed from the instant the first colliding message starts transmission to the instant that the last colliding message ceases transmission.

In all cases which contain the elements  $[S_p]_{i,j}$  and  $[J_p]_{i,k}$ , note that the maximum value of  $j + 1$  or  $k + 1$  in the summation is up to the total number of messages in that priority.

**Case 2.**  $i_h = m_h(t_p) = 0$

$$\begin{aligned}
P_r\{m_h(t'_p) = k, m_s(t'_p) = k_s, m_d(t'_p) = k_d | m_h(t_{ph}^{(r)}) = 0, m_s(t_{ph}^{(r)}) = 0, m_d(t_{ph}^{(r)}) = 0\} \\
&= \sum_{\alpha_s=0}^{M_s} \sum_{\alpha_d=0}^{M_d} [a(1, \alpha_s, \alpha_d)] [Q_h^{T_h+1} J_h]_{1,k} [Q_s^{T_h+1}]_{\alpha_s, k_s} [Q_d^{T_h+1}]_{\alpha_d, k_d} \\
&\quad + \sum_{\alpha_s=0}^{M_s} \sum_{\alpha_d=0}^{M_d} \sum_{\alpha_h=2}^k [a(\alpha_h, \alpha_s, \alpha_d)] [Q_h^{T_{ch}+1}]_{\alpha_h, k} [Q_s^{T_{ch}+1}]_{\alpha_s, k_s} [Q_d^{T_{ch}+1}]_{\alpha_d, k_d} \\
&\quad + \sum_{\alpha_d=0}^{M_d} [b(0, 1, \alpha_d)] [Q_h^{T_s+1}]_{0,k} [Q_s^{T_s+1} J_s]_{1, k_s} [Q_d^{T_s+1}]_{\alpha_d, k_d} \\
&\quad + \sum_{\alpha_d=0}^{M_d} \sum_{\alpha_s=2}^{M_s} [b(0, \alpha_s, \alpha_d)] [Q_h^{T_{cs}+1}]_{0,k} [Q_s^{T_{cs}+1}]_{\alpha_s, k_s} [Q_d^{T_{cs}+1}]_{\alpha_d, k_d} \\
&\quad + \sum_{\alpha_h=0}^{M_h} [c(0; \alpha_h; 0, 1)] [Q_h^{T_d+1}]_{\alpha_h, k} [Q_s^{T_d+1}]_{0, k_s} [Q_d^{T_d+1} J_d]_{1, k_d} \tag{3.13} \\
&\quad + \sum_{\alpha_h=0}^{M_h} \sum_{\alpha_d=2}^{M_d} [c(0; \alpha_h; 0, \alpha_d)] [Q_h^{T_{cd}+1}]_{\alpha_h, k} [Q_s^{T_{cd}+1}]_{0, k_s} [Q_d^{T_{cd}+1}]_{\alpha_d, k_d}
\end{aligned}$$

and

$$\begin{aligned}
P_r\{m_h(t'_p) = k, m_s(t'_p) = k_s, m_d(t'_p) = k_d | m_h(t_{ph}^{(r)}) = 0, m_s(t_{ph}^{(r)}) \neq 0, m_d(t_{ph}^{(r)}) \neq 0\} \\
&= \sum_{j_s=i_s}^{M_s} [Q_s^{w_m+4}]_{i_s, j_s} [P_{suc}^{(s)}(j_s) X_{j_s}^{(s)*}(Q_h) + (1 - P_{suc}^{(s)}(j_s)) X_{j_s}^{(f)*}(Q_h)]_{0,k} \tag{3.14} \\
&\quad + \sum_{j_d=i_d}^{M_d} [Q_d^{w_m+4+4}]_{i_d, j_d} [P_{suc}^{(d)}(j_d) Y_{j_d}^{(s)*}(Q_h) + (1 - P_{suc}^{(d)}(j_d)) Y_{j_d}^{(f)*}(Q_h)]_{0,k}
\end{aligned}$$

Here  $a(\cdot)$ ,  $b(\cdot)$ , and  $c(\cdot)$  are defined in Eqs. (3.16) – (3.18). Therefore, removing the condition  $m_s(t_{ph}^{(r)}) = i_s$ , or  $m_d(t_{ph}^{(r)}) = i_d$  by simply noting that, in steady state, the probability of this event is  $\pi_0^{(s)}$ , or  $\pi_0^{(d)}$ , and reusing the above probabilities, we have

$$\begin{aligned}
[P_h]_{0,k} &= P_r \{m_h(t_{ph}^{(r+1)}) = k | m_h(t_{ph}^{(r)}) = 0\} \\
&= \sum_{\alpha_s=0}^{M_s} \sum_{k_s=\alpha_s}^{M_s} \sum_{\alpha_d=0}^{M_d} \sum_{k_d=\alpha_d}^{M_d} \{ [a(1, \alpha_s, \alpha_d)] [Q_h^{T_h+1} J_h]_{1,k} [Q_s^{T_h+1}]_{\alpha_s, k_s} [Q_d^{T_h+1}]_{\alpha_d, k_d} \\
&\quad + \sum_{\alpha_h=2}^k [a(\alpha_h, \alpha_s, \alpha_d)] [Q_h^{T_{ch}+1}]_{\alpha_h, k} [Q_s^{T_{ch}+1}]_{\alpha_s, k_s} [Q_d^{T_{ch}+1}]_{\alpha_d, k_d} \} \\
&\quad + \pi_0^{(s)} \cdot \left( \sum_{k_s=0}^{M_s} \sum_{k_d=\alpha_d}^{M_d} \sum_{\alpha_d=0}^{M_d} [b(0, 1, \alpha_d)] [Q_h^{T_s+1}]_{0,k} [Q_s^{T_s+1} J_s]_{1,k_s} [Q_d^{T_s+1}]_{\alpha_d, k_d} \right. \\
&\quad + \sum_{k_s=\alpha_s}^{M_s} \sum_{k_d=\alpha_d}^{M_d} \sum_{\alpha_s=2}^{M_s} \sum_{\alpha_d=0}^{M_d} [b(0, \alpha_s, \alpha_d)] [Q_h^{T_{cs}+1}]_{0,k} [Q_s^{T_{cs}+1}]_{\alpha_s, k_s} [Q_d^{T_{cs}+1}]_{\alpha_d, k_d} \left. \right) \\
&\quad + \pi_0^{(d)} \cdot \left( \sum_{k_s=0}^{M_s} \sum_{k_d=0}^{M_d} \sum_{\alpha_h=0}^{M_h} [c(0; \alpha_h; 0, 1)] [Q_h^{T_d+1}]_{\alpha_h, k} [Q_s^{T_d+1}]_{0, k_s} [Q_d^{T_d+1} J_d]_{1, k_d} \right. \\
&\quad + \sum_{k_s=0}^{M_s} \sum_{k_d=\alpha_d}^{M_d} \sum_{\alpha_h=0}^{M_h} \sum_{\alpha_d=2}^{M_d} [c(0; \alpha_h; 0, \alpha_d)] [Q_h^{T_{cd}+1}]_{\alpha_h, k} [Q_s^{T_{cd}+1}]_{0, k_s} [Q_d^{T_{cd}+1}]_{\alpha_d, k_d} \left. \right) \quad (3.15) \\
&\quad + \pi_{i_s}^{(s)} \cdot \sum_{i_s=1}^{M_s} \sum_{j_s=i_s}^{M_s} [Q_s^{w_m+4}]_{i_s, j_s} [P_{suc}^{(s)}(j_s) X_{j_s}^{(s)*}(Q_h) + (1 - P_{suc}^{(s)}(j_s)) X_{j_s}^{(f)*}(Q_h)]_{0,k} \\
&\quad + \pi_{i_d}^{(d)} \cdot \sum_{i_d=1}^{M_d} \sum_{j_d=i_d}^{M_d} [Q_d^{w_m+4+4}]_{i_d, j_d} [P_{suc}^{(d)}(j_d) Y_{j_d}^{(s)*}(Q_h) + (1 - P_{suc}^{(d)}(j_d)) Y_{j_d}^{(f)*}(Q_h)]_{0,k}
\end{aligned}$$

where  $a(\alpha_h, \alpha_s, \alpha_d)$ ,  $b(\alpha_h, \alpha_s, \alpha_d)$  and  $C_{w_m+A_h+A_s}(i_h; \alpha_h; \alpha_s, \alpha_d)$  are defined as follows

$$[a(\alpha_h, \alpha_s, \alpha_d)] \triangleq [Q_h^{w_m}]_{0, \alpha_h} [Q_s^{w_m}]_{0, \alpha_s} [Q_d^{w_m}]_{0, \alpha_d} \quad (3.16)$$

$$[b(\alpha_h, \alpha_s, \alpha_d)] \triangleq [Q_h^{w_m+4}]_{0, \alpha_h} [Q_s^{w_m+4}]_{0, \alpha_s} [Q_d^{w_m+4}]_{0, \alpha_d} \quad (3.17)$$

$$\begin{aligned}
[c(i_h; \alpha_h; \alpha_s, \alpha_d)] &= C_{w_m+A_h+A_s}(i_h; \alpha_h; \alpha_s, \alpha_d) \\
&\triangleq [Q_h^{w_m+4}]_{0, i_h} [Q_h^4]_{i_h, \alpha_h} [Q_s^{w_m+4+4}]_{0, \alpha_s} [Q_d^{w_m+4+4}]_{0, \alpha_d} \quad (3.18)
\end{aligned}$$

and  $X_j^{(s)*}$ ,  $X_j^{(f)*}$ ,  $Y_j^{(s)*}$ ,  $Y_j^{(f)*}$ , and  $P_{suc}^{(s)}(j)$  are defined in Eqs. (3.23), (3.24), (3.32), (3.33), and (3.64), respectively.

### Derivation of the Transition Matrix $P$ ,

The idle period in the  $C_h$ -subcycle is a function of the backlog stations at the end of the minimum wait time ( $w_m$ ) plus the priority access delay ( $A_d$ ). Given that  $m_h(t_{ph}^{(r)} + w_m) = k$ , the length of the idle period, denoted by  $I_k^{(p)}$ , is geometrically distributed.

The  $z$ -transform  $I_k^{(p)*}(z)$  of the probability mass function of  $I_k^{(p)}$  is derived in Appendix B and is found to be expressed as

$$I_k^{(p)*}(z) = \frac{(1 - d_k^{(p)})z}{1 - d_k^{(p)}z} \quad (3.19)$$

where superscript ( $p$ ) indicates the priority of the messages and  $d_k^{(p)}$  is equal to  $(1 - \nu_p)^{k_p}(1 - g_p)^{M_p - k_p}$ .

Given that  $m_h(t_{ph}^{(r)} + w_m) = k$ , the length of the  $C_h$ -cycle denoted by  $O_k$  relies on the success or failure in the transmission. In case of successful transmission,  $O_k^{(s)}$  is equal to  $w_m + I_k^{(h)} + T_h + 1$  and has a moment generating function [17], [20]  $O_k^{(s)*}(z)$  written as

$$O_k^{(s)*}(z) = \frac{(1 - d_k^{(h)})z^{1+w_m+T_h+1}}{1 - d_k^{(h)}z} \quad (3.20)$$

Similarly,  $O_k^{(f)}$  may be defined for the case of failure as  $O_k^{(f)} = w_m + I_k^{(h)} + T_{ch} + 1$  and its moment generating function is given by

$$O_k^{(f)*}(z) = \frac{(1 - d_k^{(h)})z^{1+w_m+T_{ch}+1}}{1 - d_k^{(h)}z} \quad (3.21)$$

Let us define  $q_{h;i,j}$  as the length of the  $C_h$ -subcycle, given that  $m_h(t_{ph}^{(r)}) = i$  and  $m_h(t_{ph}^{(r+1)}) = j$ . Therefore,  $q_{h;i,j}$  becomes  $t_{ph}^{(r+1)} - t_{ph}^{(r)}$ , where  $t_{ph}^{(r)}$ ,  $t_{ph}^{(r+1)}$  are two consecutive embedded points. Let  $q_{h;i,j}^*(z)$  denote the generating function of the probability mass function of  $q_{h;i,j}$ . This generating function can be expressed as

$$q_{h;i,j}^*(z) = \sum_{k=i}^{j+1} \frac{[Q_h^{w_m}]_{i,k} [S_h Q_h^{T_h+1} J_h]_{k,j}}{[p_h]_{i,j}} O_k^{(s)*}(z) + \sum_{k=i}^j \frac{[Q_h^{w_m}]_{i,k} [F_h Q_h^{T_{ch}+1}]_{k,j}}{[p_h]_{i,j}} O_k^{(f)*}(z)$$



$$\begin{aligned}
&= \sum_{k=i}^{j+1} \frac{[Q_h^{w_m}]_{i,k} [S_h Q_h^{T_h+1} J_h]_{k,j}}{[p_h]_{i,j}} \cdot \frac{(1 - d_k^{(h)}) z^{1+w_m+T_h+1}}{1 - d_k^{(h)} z} \\
&+ \sum_{k=i}^j \frac{[Q_h^{w_m}]_{i,k} [F_h Q_h^{T_{ch}+1}]_{k,j}}{[p_h]_{i,j}} \cdot \frac{(1 - d_k^{(h)}) z^{1+w_m+T_{ch}+1}}{1 - d_k^{(h)} z} \tag{3.22}
\end{aligned}$$

Let us define  $L_{n_h} \equiv T_{ps}^{(r+1)} - t'_p$  to be  $\beta$ , conditioned on  $m_h(t'_p) = n_h$ . Here  $\beta$  is the number of time slots it takes for the process  $m_h(t_{p_h})$  to reach state 0, starting in state  $n_h$ , and  $t'_p$  denotes the time of the first EOP, following  $T_{ps}^{(r)}$ . If  $n_h = 0$ , then  $L_0 = 0$  with probability 1. Given that  $m_h(t'_p) = n_h$  and  $L_{n_h} = \beta$ , the transition matrix of  $M_s(t)$  over the entire sequence of  $C_h$ -subcycles is simply  $Q_s^\beta$ . If we remove the condition on  $\beta$ , this becomes  $L_{n_h}^*(Q_s)$ . By the recursive Markov chains, (see Appendix A) the generating function  $L_{n_h}^*(z)$  for  $L_{n_h}$  can be given by

$$L_{n_h}^*(z) = \sum_{j=n_h-1}^{M_s} [P_h]_{n_h,j} q_{h;n_h,j}^*(z) L_j^*(z) \tag{3.23}$$

Note that for  $n_h = 0$ ,  $L_0^* = 1$ . All messages of high priority in a  $C_s$  subcycle will accumulate at the end of the  $C_s$ -subcycle. So, the higher message initiates the new sequence of consecutive  $C_h$ -subcycles until there is no message.

Given that  $m_s(t_{ps}^{(r)} + w_m + 4) = k$ , the length of the  $C_s$ -cycle denoted by  $X_k^{(s)}$  is equal to  $w_m + 4 + I_k^{(s)} + T_s + 1$  in case of successful transmission. Its moment generating function  $X_k^{(s)*}(z)$  is given by

$$X_k^{(s)*}(z) = \frac{(1 - d_k^{(s)}) z^{1+w_m+4+T_s+1}}{1 - d_k^{(s)} z} \tag{3.24}$$

Where  $I_k^{(s)}$  has the same distribution as  $I_k^{(h)}$  with parameter  $d_k^{(s)} = (1 - \nu_s)^{k_s} (1 - g_s)^{M_s - k_s}$ . Similarly, in case of failure, the moment generating function  $X_k^{(f)*}(z)$  of the  $X_k^{(f)}$  may be written as

$$X_k^{(f)*}(z) = \frac{(1 - d_k^{(s)}) z^{1+w_m+4+T_{cs}+1}}{1 - d_k^{(s)} z} \tag{3.25}$$

Let us define a transient moment generating function  $X^{(l)*}(z)$  during  $l$  slots over

the Standard priority as

$$X_k^{l*}(z) = \frac{(1 - d_k^{(s)})z^l}{1 - d_k^{(s)}z} \quad (3.26)$$

If we assume the length of the  $C_s$ -subcycle is  $x$  slots, the probability that  $m_h(t'_p) = n_h$  can be expressed as  $[Q_h^x]_{0, n_h}$ .

Transition probabilities between  $t_{ps}^{(r)}$  and  $t'_p$  are written in 2 cases:

**Case 1.**  $m_s(t_p) = i_s \neq 0$

$$\begin{aligned} [P_s]_{i_s, j} &= P_r \{m_s(t_{ps}^{(r+1)}) = j | m_s(t_{ps}^{(r)}) = i_s\} \\ &= \sum_{k=i}^{j+1} [Q_s^{w_{m+4}}]_{i_s, k_s} \left[ \sum_{n_h=0}^{M_h} [Q_h^x]_{0, n_h} S_s Q_s^{T_s+1} J_s Q_s^\beta \right]_{k_s, j} \\ &\quad + \sum_{k=i}^j [Q_s^{w_{m+4}}]_{i_s, k_s} \left[ \sum_{n_h=0}^{M_h} [Q_h^x]_{0, n_h} F_s Q_s^{T_{cs}+1} Q_s^\beta \right]_{k_s, j} \end{aligned} \quad (3.27)$$

Removing the condition on  $x$  from  $[Q_h^x]_{0, n_h}$ , the probability is given by  $[X_k^{(s)*}(Q_h)]_{0, n_h}$  in case of success, and  $[X_k^{(f)*}(Q_h)]_{0, n_h}$  in case of failure. Therefore,

$$\begin{aligned} [P_s]_{i_s, j} &= P_r \{m_s(t_{ps}^{(r+1)}) = j | m_s(t_{ps}^{(r)}) = i_s\} \\ &= \sum_{k_s=i_s}^{j+1} [Q_s^{w_{m+4}}]_{i_s, k_s} \left[ S_s Q_s^{T_s+1} J_s \sum_{n_h=0}^{M_h} [X_{k_s}^{(s)*}(Q_h)]_{0, n_h} L_{n_h}^*(Q_s) \right]_{k_s, j} \\ &\quad + \sum_{k_s=i_s}^j [Q_s^{w_{m+4}}]_{i_s, k_s} \left[ F_s Q_s^{T_{cs}+1} \sum_{n_h=0}^{M_h} [X_{k_s}^{(f)*}(Q_h)]_{0, n_h} L_{n_h}^*(Q_s) \right]_{k_s, j} \end{aligned} \quad (3.28)$$

**Case 2.**  $i_s = m_s(t_p) = 0$

Transition probabilities between  $t_{ps}^{(r)}$  and  $t'_p$  may be written as

$$\begin{aligned} P_r \{m_h(t'_p) = k_h, m_s(t'_p) = k_s, m_d(t'_p) = k_d | m_h(t_{ps}^{(r)}) = 0, m_s(t_{ps}^{(r)}) = 0, m_d(t_{ps}^{(r)}) = 0\} \\ = P_{r|ps}^a + P_{r|ps}^b + P_{r|ps}^c \end{aligned} \quad (3.29)$$

where

$$\begin{aligned} P_{r|ps}^a &= P_r \{m_h(t'_p) = k_h, m_s(t'_p) = k_s, m_d(t'_p) = k_d | m_h(t_{ps}^{(r)}) = 0, m_s(t_{ps}^{(r)}) = 0, m_d(t_{ps}^{(r)}) = 0\} \\ &= \sum_{\alpha_s=0}^{M_s} \sum_{\alpha_d=0}^{M_d} [a(1, \alpha_s, \alpha_d)] [Q_h^{T_h+1} J_h]_{1, k_h} [Q_s^{T_h+1}]_{\alpha_s, k_s} [Q_d^{T_h+1}]_{\alpha_d, k_d} \\ &\quad + \sum_{\alpha_h=2}^{M_s} \sum_{\alpha_s=0}^{M_s} \sum_{\alpha_d=0}^{M_d} [a(\alpha_h, \alpha_s, \alpha_d)] [Q_h^{T_{ch}+1}]_{0, k_h} [Q_s^{T_{ch}+1}]_{\alpha_s, k_s} [Q_d^{T_{ch}+1}]_{\alpha_d, k_d} \end{aligned} \quad (3.30)$$

$$\begin{aligned}
P_{r|ps}^b &= P_r^b \{m_h(t'_p) = k_h, m_s(t'_p) = k_s, m_d(t'_p) = k_d | m_h(t_{ps}^{(r)}) = 0, m_s(t_{ps}^{(r)}) = 0, m_d(t_{ps}^{(r)}) = 0\} \\
&= \sum_{\alpha_d=0}^{M_d} [b(0, 1, \alpha_d)] [Q_h^{T_s+1}]_{0,k_h} [Q_s^{T_s+1} J_s]_{1,k_s} [Q_d^{T_s+1}]_{\alpha_d,k_d} \\
&\quad + \sum_{\alpha_s=2}^{M_s} \sum_{\alpha_d=0}^{M_d} [b(0, \alpha_s, \alpha_d)] [Q_h^{T_{cs}+1}]_{0,k_h} [Q_s^{T_{cs}+1}]_{\alpha_s,k_s} [Q_d^{T_{cs}+1}]_{\alpha_d,k_d}
\end{aligned} \tag{3.31}$$

$$\begin{aligned}
P_{r|ps}^c &= P_r^c \{m_h(t'_p) = k_h, m_s(t'_p) = k_s, m_d(t'_p) = k_d | m_h(t_{ps}^{(r)}) = 0, m_s(t_{ps}^{(r)}) = 0, m_d(t_{ps}^{(r)}) = 0\} \\
&= \sum_{\alpha_h=0}^{M_h} [c(0; \alpha_h; 0, 1)] [Q_h^{T_d+1}]_{\alpha_h,k_h} [Q_s^{T_d+1}]_{0,k_s} [Q_d^{T_d+1} J_d]_{1,k_d} \\
&\quad + \sum_{\alpha_h=0}^{M_h} \sum_{\alpha_d=2}^{M_d} [c(0; \alpha_h; 0, \alpha_d)] [Q_h^{T_{cd}+1}]_{\alpha_h,k_h} [Q_s^{T_{cd}+1}]_{0,k_s} [Q_d^{T_{cd}+1}]_{\alpha_d,k_d}
\end{aligned} \tag{3.32}$$

$$\begin{aligned}
P_{r|ps}^c &= P_r^c \{m_s(t_{ps}^{(r+1)}) = j_s | m_h(t_{ps}^{(r)}) = 0, m_s(t_{ps}^{(r)}) = 0, m_d(t_{ps}^{(r)}) = i_d \neq 0\} \\
&= \sum_{j_d=i_d}^{M_d} [Q_s]^{w_m+4+4} |_{i_d,j_d} [P_{suc}^{(d)}(j_d) Y_{j_d}^{(s)*}(Q_s) + (1 - P_{suc}^{(d)}(j_d)) Y_{j_d}^{(f)*}(Q_s)]_{0,j_s}
\end{aligned} \tag{3.33}$$

Here,  $a(\alpha_h, \alpha_s, \alpha_d)$ ,  $b(\alpha_h, \alpha_s, \alpha_d)$  and  $c(i_h; \alpha_h; \alpha_s, \alpha_d)$  are defined by Eqs. (3.16), (3.17) and (3.18), respectively.

Removing the condition  $m_d(t_{ps}^{(r)}) = i_d$  by simply noting that, in steady state, the probability of this event is  $\pi_0^{(d)}$ , we get

$$\begin{aligned}
[P_s]_{0,j} &= P_r \{m_s(t_{ps}^{(r+1)}) = j | m_s(t_{ps}^{(r)}) = 0\} \\
&= \sum_{k_d=0}^{M_d} P_r^a \{m_h(t'_p) = 0, m_s(t'_p) = j, m_d(t'_p) = k_d \\
&\quad | m_h(t_{ps}^{(r)}) = 0, m_s(t_{ps}^{(r)}) = 0, m_d(t_{ps}^{(r)}) = 0\} \\
&\quad + \sum_{k_h=1}^{M_h} \sum_{k_s=0}^j \sum_{k_d=0}^{M_d} P_r^a \{m_h(t'_p) = k_h, m_s(t'_p) = k_s, m_d(t'_p) = k_d \\
&\quad | m_h(t_{ps}^{(r)}) = 0, m_s(t_{ps}^{(r)}) = 0, m_d(t_{ps}^{(r)}) = 0\} [L_{k_h}^*(Q_s)]_{k_s,j} \\
&\quad + \sum_{k_d=0}^{M_d} P_r^b \{m_h(t'_p) = 0, m_s(t'_p) = j, m_d(t'_p) = k_d \\
&\quad | m_h(t_{ps}^{(r)}) = 0, m_s(t_{ps}^{(r)}) = 0, m_d(t_{ps}^{(r)}) = 0\} \\
&\quad + \sum_{k_h=1}^{M_h} \sum_{k_s=0}^j \sum_{k_d=0}^{M_d} P_r^b \{m_h(t'_p) = k_h, m_s(t'_p) = k_s, m_d(t'_p) = k_d
\end{aligned}$$

$$\begin{aligned}
& |m_h(t_{ps}^{(r)}) = 0, m_s(t_{ps}^{(r)}) = 0, m_d(t_{ps}^{(r)}) = 0\{L_{k_h}^*(Q_s)\}_{k_s, j} \\
& + \pi_0^{(d)} \cdot \left( \sum_{k_d=\alpha_d}^{M_d} P_r^c \{m_h(t'_p) = 0, m_s(t'_p) = j, m_d(t'_p) = k_d \right. \\
& |m_h(t_{ps}^{(r)}) = 0, m_s(t_{ps}^{(r)}) = 0, m_d(t_{ps}^{(r)}) = 0\} \\
& + \sum_{k_h=1}^{M_h} \sum_{k_s=0}^j \sum_{k_d=0}^{M_d} P_r^c \{m_h(t'_p) = k_h, m_s(t'_p) = k_s, m_d(t'_p) = k_d \\
& |m_h(t_{ps}^{(r)}) = 0, m_s(t_{ps}^{(r)}) = 0, m_d(t_{ps}^{(r)}) = 0\} \Big) \tag{3.34} \\
& + \pi_{i_d}^{(d)} \cdot \sum_{i_d=1}^{M_d} P_r^c \{m_s(t_{ps}^{(r+1)}) = j \\
& |m_h(t_{ps}^{(r)}) = 0, m_s(t_{ps}^{(r)}) = 0, m_d(t_{ps}^{(r)}) = i_d\}
\end{aligned}$$

where  $i_d \neq 0$ .

### Derivation of the Transition Matrix $P_d$

The Transition matrix  $[P_d]_{i_d, l}$  is a function of  $C_d$ -subcycle immediately following  $t_{pd}^{(r)}$ , and a succession of  $C_h$ -subcycles for as long as  $m_h(t'_p) \neq 0$  and  $C_s$ -subcycles for as long as  $m_s(t'_p) \neq 0$ . Let us first define  $q_{n_h, j_h; n_s, j_s}$  as the length of the combination of  $C_h$  and  $C_s$ -subcycles, given that  $m_h(t_{ph}^{(r)}) = n_h$ ,  $m_h(t_{ph}^{(r+1)}) = j_h$ ,  $m_s(t_{ps}^{(r)}) = n_s$  and  $m_s(t_{ps}^{(r+1)}) = j_s$ . Therefore  $q_{n_h, j_h; n_s, j_s}$  becomes the combination of  $(t_{ph}^{(r+1)} - t_{ph}^{(r)})$  and  $(t_{ps}^{(r+1)} - t_{ps}^{(r)})$ , where  $t_{ps}^{(r)}, t_{ps}^{(r+1)}$  are two consecutive embedded points. Let  $q_{n_h, j_h; n_s, j_s}^*(z)$  denote the generating function of the probability mass function of  $q_{n_h, j_h; n_s, j_s}$ . This generating function can be expressed as

if  $n_h \neq 0$

$$\begin{aligned}
q_{n_h, j_h; n_s, j_s}^*(z) & = \\
& = \sum_{k_h=1}^{j_h+1} \sum_{k_s=n_s}^{j_s} \frac{[Q_h^{w_m}]_{1, k_h} [Q_s^{w_m}]_{n_s, k_s} [S_h Q_h^{T_h+1} J_h]_{k_h, j_h} [Q_s^{T_h+1}]_{k_s, j_s}}{[p_h]_{1, j_h} [p_s]_{n_s, j_s}} \\
& \quad \cdot \frac{(1 - d_k^h) z^{1+w_m+T_h+1}}{1 - d_k^h z} \\
& + \sum_{k_h=1}^{j_h} \sum_{k_s=n_s}^{j_s} \frac{[Q_h^{w_m}]_{1, k_h} [Q_s^{w_m}]_{n_s, k_s} [F_h Q_h^{T_{ch}+1}]_{k_h, j_h} [Q_s^{T_{ch}+1}]_{k_s, j_s}}{[p_h]_{1, j_h} [p_s]_{n_s, j_s}}
\end{aligned}$$

$$\frac{(1 - d_k^h)z^{1+w_m+T_{ch}+1}}{1 - d_k^h z} \quad (3.35)$$

if  $n_h = 0$

$$\begin{aligned} q_{n_h, j_h; n_s, j_s}^* (z) &= \sum_{k_h=0}^{j_h} \sum_{k_s=1}^{j_s+1} \frac{[Q_h^{w_m+4}]_{0, k_h} [Q_s^{w_m+4}]_{1, k_s} [Q_h^{T_s+1}]_{k_h, j_h} [S_s Q_s^{T_s+1} J_s]_{k_s, j_s}}{[p_h]_{0, j_h} [p_s]_{1, j_s}} \\ &\quad \cdot \frac{(1 - d_k^s)z^{1+w_m+T_h+1}}{1 - d_k^s z} \\ &+ \sum_{k_h=0}^{j_h} \sum_{k_s=n_s}^{j_s} \frac{[Q_h^{w_m+4}]_{0, k_h} [Q_s^{w_m+4}]_{n_s, k_s} [Q_h^{T_s+1}]_{k_h, j_h} [F_s Q_s^{T_{cs}+1}]_{k_s, j_s}}{[p_h]_{0, j_h} [p_s]_{1, j_s}} \\ &\quad \cdot \frac{(1 - d_k^s)z^{1+w_m+T_h+1}}{1 - d_k^s z} \end{aligned} \quad (3.36)$$

Let  $L_{n_h, n_s} \equiv T_{pd}^{(r+1)} - t'_p \triangleq u$ , conditioned on  $m_h(t'_p) = n_h$  and  $m_s(t'_p) = n_s$ . Here  $u$  is the time in slots that it takes for the processes  $m_h(t_{ph})$  and  $m_s(t_{ps})$  to reach state 0, starting in state  $n_h$  and  $n_s$ , at the end of the transmission. The time of the instant  $t'_p$  denotes the time of the first EOP, following  $T_{pd}^{(r)}$ . Let,  $L_{j_h, i_s} = 0$  with probability 1 for  $j_h = j_s = 0$ . Given that  $m_h(t'_p) = n_h$ ,  $m_s(t'_p) = n_s$  and  $L_{n_h, n_s} = u$ , the transition matrix of  $M_d(t)$  over the entire sequence of  $C_h$  and  $C_s$  -subcycles is simply  $Q_d^u$ . If we remove the condition on  $u$ , this becomes  $L_{n_h, n_s}^*(Q_d)$ . By the recursive Markov chains, the generating function  $L_{n_h, n_s}^*(Q_d)$  for  $L_{n_h, n_s}$  can be computed by

$$\begin{aligned} L_{n_h, n_s}^*(z) &= \sum_{j_h=n_h-1}^{M_h} \sum_{j_s=n_s-1}^{M_s} [P_h]_{n_h, j_h} [P_s]_{n_s, j_s} q_{n_h, j_h; n_s, j_s}^*(z) L_{j_h, j_s}^*(z) \end{aligned} \quad (3.37)$$

Note that  $[P_h]_{n_h, j_h} = 0$  for  $j_h < n_h - 1$ ,  $[P_s]_{n_s, j_s} = 0$  for  $j_s < n_s - 1$ , and  $L_{j_h, i_s}^*(z) = 1$  for  $j_h = 0$  and/or  $j_s = 0$ , respectively. Since  $L_{0,0}^*(z) = 1$ , we get  $L_{0,0}^*(Q_d) = Q_d^0 = I_d$ . Expression (4.28) can be computed numerically using successive iterations given the initial distributions since it results in  $M_s$  equations with  $M_s$  unknowns.

All messages of higher priority in a  $C_d$  subcycle will accumulate at the end of the  $C_d$ -subcycle. So, the higher messages will initiate a new sequence of consecutive  $C_h$  and  $C_s$ -subcycles until no more remain. During all  $C_h$  and  $C_s$ -subcycles, new message arrivals of Deferred priority become backlogged.

Given that  $m_d(t_{pd}^{(r)} + w_m + 8)$  and the transmission period  $TP_d$ , the length of the  $C_d$ -cycle denoted by  $Y_k$  is equal to  $w_m + 8 + I_k^{(d)} + TP_d + 1$ . Here,  $TP_d$  indicates  $T_d + 1$  in case of success and  $T_{cd} + 1$  in case of failure. The moment generating function  $Y_k^{(s)*}(z)$  of the  $Y_k$  with successful transmission can be expressed as

$$Y_k^{(s)*}(z) = \frac{(1 - d_k^{(d)})z^{w_m + T_d + 10}}{1 - d_k^{(d)}z} \quad (3.38)$$

Similarly,  $Y_k^{(f)}$  can be defined for the case of failure as  $Y_k^{(f)} = w_m + I_k^{(d)} + T_{cd} + 1$  and its moment generating function is written by

$$Y_k^{(f)*}(z) = \frac{(1 - d_k^{(d)})z^{w_m + T_{cd} + 10}}{1 - d_k^{(d)}z} \quad (3.39)$$

Let us denote a transient moment generating function during  $l$  slots over the Deferred priority as  $Y^{l*}(z)$  so that we have

$$Y_k^{l*}(z) = \frac{(1 - d_k^{(s)})z^l}{1 - d_k^{(s)}z} \quad (3.40)$$

If we assume the length of the  $C_d$ -subcycle is  $y$  slots, the transition probabilities  $m_h(t'_p) = n_h$  and  $m_s(t'_p) = n_s$  over the  $y$  slots become  $[Q_h^y]_{0, n_h}$  and  $[Q_s^y]_{0, n_s}$ .

**Case 1.**  $i_d \neq 0$

The  $(i_d, l)$ th element of matrix  $P_d$  can be written as

$$\begin{aligned} [P_d]_{i_d, l} = & \sum_{k_d=i_d}^{l+1} [Q_s^{w_m + A_h + A_s}]_{i_d, k_d} \left[ \sum_{n_h=0}^{M_h} \sum_{n_s=0}^{M_s} [Q_h^y]_{0, n_h} [Q_s^y]_{0, n_s} S_d Q_d^{T_d+1} J_d Q_d^u \right]_{k_d, l} \\ & + \sum_{k_d=i_d}^l [Q_s^{w_m + A_h + A_s}]_{i_d, k_d} \left[ \sum_{n_h=0}^{M_h} \sum_{n_s=0}^{M_s} [Q_h^y]_{0, n_h} [Q_s^y]_{0, n_s} F_d Q_d^{T_{cd}+1} Q_d^u \right]_{k_d, l} \end{aligned} \quad (3.41)$$

Removing the condition on  $y$  from  $[Q_h^y]_{0,n_h}$  and  $[Q_s^y]_{0,n_s}$ , the probabilities are  $[Y_{k_d}^{(s)*}(Q_h)]_{0,n_h}$  and  $[Y_{k_d}^{(s)*}(Q_s)]_{0,n_s}$  in case of success, and  $[Y_{k_d}^{(f)*}(Q_h)]_{0,n_h}$  and  $[Y_{k_d}^{(f)*}(Q_s)]_{0,n_s}$  in case of failure. Therefore, the  $(i_d, l)$ th element of matrix  $[P_d]$  for  $i_d \neq 0$  is given by

$$\begin{aligned}
[P_d]_{i_d, l} &= \sum_{k_d=i_d}^{l+1} [Q_d^{w_{m+A_h+A_s}}]_{i_d, k_d} \left[ \sum_{n_h=0}^{M_h} \sum_{n_s=0}^{M_s} [Y_{k_d}^{(s)*}(Q_h)]_{0, n_h} [Y_{k_d}^{(s)*}(Q_s)]_{0, n_s} \right. \\
&\quad \cdot S_d Q_d^{T_d+1} J_d L_{n_h, n_s}^*(Q_d) \\
&\quad \left. + \sum_{n_h=0}^{M_h} \sum_{n_s=0}^{M_s} [Y_{k_d}^{(f)*}(Q_h)]_{0, n_h} [Y_{k_d}^{(f)*}(Q_s)]_{0, n_s} \cdot F_d Q_d^{T_{cd}+1} L_{n_h, n_s}^*(Q_d) \right]_{k_d, l}
\end{aligned} \tag{3.42}$$

Case 2.  $i_d = m_d(t_p) = 0$

Transition probabilities between  $t_{p_d}^{(r)}$  and  $t'_p$  are written as

$$\begin{aligned}
P_r \{m_h(t'_p) = n_h, m_s(t'_p) = n_s, m_d(t'_p) = n_d | m_h(t_{p_d}^{(r)}) = 0, m_s(t_{p_d}^{(r)}) = 0, m_d(t_{p_d}^{(r)}) = 0\} \\
= P_{r|p_d}^a + P_{r|p_d}^b + P_{r|p_d}^c
\end{aligned} \tag{3.43}$$

Here,  $P_{r|p_d}^a$ ,  $P_{r|p_d}^b$  and  $P_{r|p_d}^c$  are similar to the expressions provided in Eqs. (4.30) to (4.32) except that in the expression for  $t_{p_d}^{(r)}$ , instead of  $k_h, k_s$  and  $k_d$ , the parameters  $n_h, n_s$  and  $n_d$  are used, respectively.

Similarly, the  $(0, l)$  element of matrix  $[P_d]$  for  $i_d = 0$  is found to be given by the lengthy expression

$$\begin{aligned}
[P_d]_{0, l} &= P_r \{m_d(t_{p_d}^{(r+1)}) = l | m_d(t_{p_d}^{(r)}) = 0\} \\
&= P_r^a \{m_h(t'_p) = 0, m_s(t'_p) = 0, m_d(t'_p) = l \\
&\quad | m_h(t_{p_s}^{(r)}) = 0, m_s(t_{p_s}^{(r)}) = 0, m_d(t_{p_s}^{(r)}) = 0\} \\
&\quad + \sum_{n_d=\alpha_d}^l P_r^a \{m_h(t'_p) = 1, m_s(t'_p) = 0, m_d(t'_p) = n_d \\
&\quad | m_h(t_{p_s}^{(r)}) = 0, m_s(t_{p_s}^{(r)}) = 0, m_d(t_{p_s}^{(r)}) = 0\} [L_{n_h=1, n_s=0}^*(Q_d)]_{n_d, l} \\
&\quad + \sum_{n_d=\alpha_d}^l P_r^a \{m_h(t'_p) = 0, m_s(t'_p) = 1, m_d(t'_p) = n_d \\
&\quad | m_h(t_{p_s}^{(r)}) = 0, m_s(t_{p_s}^{(r)}) = 0, m_d(t_{p_s}^{(r)}) = 0\} [L_{n_h=0, n_s=1}^*(Q_d)]_{n_d, l}
\end{aligned}$$

$$\begin{aligned}
& + \sum_{n_h=1}^{M_h} \sum_{n_s=1}^{M_s} \sum_{n_d=\alpha_d}^l P_r^a \{m_h(t'_p) = n_h, m_s(t'_p) = n_s, m_d(t'_p) = n_d \\
& |m_h(t_{ps}^{(r)}) = 0, m_s(t_{ps}^{(r)}) = 0, m_d(t_{ps}^{(r)}) = 0\} [L_{n_h, n_s}^*(Q_d)]_{n_d, l} \\
& + P_r^b \{m_h(t'_p) = 0, m_s(t'_p) = 0, m_d(t'_p) = l \\
& |m_h(t_{ps}^{(r)}) = 0, m_s(t_{ps}^{(r)}) = 0, m_d(t_{ps}^{(r)}) = 0\} \\
& + \sum_{n_d=\alpha_d}^l P_r^b \{m_h(t'_p) = 1, m_s(t'_p) = 0, m_d(t'_p) = n_d \\
& |m_h(t_{ps}^{(r)}) = 0, m_s(t_{ps}^{(r)}) = 0, m_d(t_{ps}^{(r)}) = 0\} [L_{n_h=1, n_s=0}^*(Q_d)]_{n_d, l} \\
& + \sum_{n_d=\alpha_d}^l P_r^b \{m_h(t'_p) = 0, m_s(t'_p) = 1, m_d(t'_p) = n_d \\
& |m_h(t_{ps}^{(r)}) = 0, m_s(t_{ps}^{(r)}) = 0, m_d(t_{ps}^{(r)}) = 0\} [L_{n_h=0, n_s=1}^*(Q_d)]_{n_d, l} \\
& + \sum_{n_h=1}^{M_h} \sum_{n_s=1}^{M_s} \sum_{n_d=\alpha_d}^l P_r^a \{m_h(t'_p) = n_h, m_s(t'_p) = n_s, m_d(t'_p) = n_d \\
& |m_h(t_{ps}^{(r)}) = 0, m_s(t_{ps}^{(r)}) = 0, m_d(t_{ps}^{(r)}) = 0\} [L_{n_h, n_s}^*(Q_d)]_{n_d, l} \\
& + P_r^c \{m_h(t'_p) = 0, m_s(t'_p) = 0, m_d(t'_p) = l \\
& |m_h(t_{ps}^{(r)}) = 0, m_s(t_{ps}^{(r)}) = 0, m_d(t_{ps}^{(r)}) = 0\} \tag{3.44} \\
& + \sum_{n_d=\alpha_d}^l P_r^c \{m_h(t'_p) = 1, m_s(t'_p) = 0, m_d(t'_p) = n_d \\
& |m_h(t_{ps}^{(r)}) = 0, m_s(t_{ps}^{(r)}) = 0, m_d(t_{ps}^{(r)}) = 0\} [L_{n_h=1, n_s=0}^*(Q_d)]_{n_d, l} \\
& + \sum_{n_d=\alpha_d}^l P_r^c \{m_h(t'_p) = 0, m_s(t'_p) = 1, m_d(t'_p) = n_d \\
& |m_h(t_{ps}^{(r)}) = 0, m_s(t_{ps}^{(r)}) = 0, m_d(t_{ps}^{(r)}) = 0\} [L_{n_h=0, n_s=1}^*(Q_d)]_{n_d, l} \\
& + \sum_{n_h=1}^{M_h} \sum_{n_s=1}^{M_s} \sum_{n_d=\alpha_d}^l P_r^c \{m_h(t'_p) = n_h, m_s(t'_p) = n_s, m_d(t'_p) = n_d \\
& |m_h(t_{ps}^{(r)}) = 0, m_s(t_{ps}^{(r)}) = 0, m_d(t_{ps}^{(r)}) = 0\} [L_{n_h, n_s}^*(Q_d)]_{n_d, l}
\end{aligned}$$

### 3.2.3 Expected Length of Cycles and Backlogs of each Priority

#### Expected Length of a $C_h$ -Cycle

The methods of finding the expected length of cycles and backlogs of each priority are similar to those employed in [59]. Time axis slotting and Markov chain analysis are



used to determine the channel backlog in a cycle. A cycle includes the minimum wait time, priority channel access delay and the transmission time between two consecutive embedded points.

**Case 1.**  $m_h(t_{ph}^{(r)}) = i_h \neq 0$

$$\begin{aligned}
E [ t_{ph}^{(r+1)} - t_{ph}^{(r)} | m_h(t_{ph}^{(r)}) = i_h \neq 0 ] &= \\
&= \sum_{\alpha_h=i_h}^{M_h} [Q_h^{w_m}]_{i_h, \alpha_h} [w_m + \bar{I}_{\alpha_h} + P_{suc}^{(h)}(\alpha_h)(T_h + 1) \\
&\quad + (1 - P_{suc}^{(h)}(\alpha_h))(T_{ch} + 1)] \tag{3.45}
\end{aligned}$$

**Case 2.**  $m_h(t_{ph}^{(r)}) = i_h = 0$

$$\begin{aligned}
E [ t_{ph}^{(r+1)} - t_{ph}^{(r)} | m_h(t_{ph}^{(r)}) = i_h = 0 ] &= w_m + a(0, 0, 0)\bar{I}_0 \\
&+ \sum_{\alpha_s=0}^{M_s} \sum_{\alpha_d=0}^{M_d} [a(1, \alpha_s, \alpha_d)]T_h + \sum_{\alpha_h=2}^{M_h} \sum_{\alpha_s=0}^{M_s} \sum_{\alpha_d=0}^{M_d} [a(\alpha_h, \alpha_s, \alpha_d)]T_{ch} \\
&+ \sum_{\alpha_d=0}^{M_d} [b(0, 1, \alpha_d)]T_s + \sum_{\alpha_s=2}^{M_s} \sum_{\alpha_d=0}^{M_d} [b(0, \alpha_s, \alpha_d)]T_{cs} \\
&+ \sum_{\alpha_h=0}^{M_h} [c(0; \alpha_h; 0, 1)]T_d + \sum_{\alpha_h=0}^{M_h} \sum_{\alpha_d=2}^{M_d} [c(0; \alpha_h; 0, \alpha_d)]T_{cd} \\
&+ \sum_{j=i_s}^{M_s} [Q_h^{w_m+4}]_{i_s, j} [w_m + 4 + \bar{I}_j^{(s)} + P_{suc}^{(s)}(j)(T_s + 1) \\
&\quad + (1 - P_{suc}^{(s)}(j))(T_{cs} + 1)] \tag{3.46}
\end{aligned}$$

$$\begin{aligned}
&+ \sum_{l=i_d}^{M_d} [Q_h^{w_m+8}]_{i_d, l} [w_m + 4 + 4 + \bar{I}_l^{(d)} + P_{suc}^{(d)}(l)(T_d + 1) \\
&\quad + (1 - P_{suc}^{(d)}(l))(T_{cd} + 1)] \tag{3.47}
\end{aligned}$$

Here,  $\bar{I}_0$  is given by

$$\bar{I}_0 = \frac{1}{1 - (1 - g_h)^{M_h}(1 - g_s)^{M_s}(1 - g_d)^{M_d}} \tag{3.48}$$

where  $a(\alpha_h, \alpha_s, \alpha_d)$  was given in Eq. (4.16).

### Expected Sum of High Priority Backlogs over a $C_h$ -Cycle

The expected sum of the backlog over the cycle is provided for 2 cases, given that  $i_h \neq 0$  and  $i_h = 0$ , respectively.

**Case 1.**  $m_h(t_{ph}^{(r)}) = i_h \neq 0$

$$\begin{aligned}
E \left[ \sum_{t=t_{ph}^{(r)}}^{t_{ph}^{(r+1)}-1} m_h(t) \mid m_h(t_{ph}^{(r)}) = i_h \neq 0 \right] &= \\
&= [(I_h + Q_h + Q_h^2 + \dots + Q_h^5)H_h]_{i_h} \\
&\quad + \sum_{k_h=i_h}^{M_h} [Q_h^{u_m}]_{i_h, k_h} k_h \bar{I}_{k_h} \\
&\quad + \sum_{k_h=i_h}^{M_h} [Q_h^{u_m}]_{i_h, k_h} \left[ S_h(I_h + Q_h + Q_h^2 + \dots + Q_h^{T_h})H_h \right. \\
&\quad \left. + F_h(I_h + Q_h + Q_h^2 + \dots + Q_h^{T_{ch}})H_h \right]_{k_h}
\end{aligned} \tag{3.49}$$

where

$$\bar{I}_{k_h} = \frac{1}{1 - (1 - \nu_h)^{k_h} (1 - g_h)^{M_h - k_h}} \tag{3.50}$$

and  $H_h$  is the column vector made up of the index values of the messages, i.e., its transpose is  $H_h^T = (0, 1, 2, \dots, M_h)$ .

**Case 2.**  $m_h(t_{ph}^{(r)}) = i_h = 0$

$$\begin{aligned}
E \left[ \sum_{t=t_{ph}^{(r)}}^{t_{ph}^{(r+1)}-1} m_h(t) \mid m_h(t_{ph}^{(r)}) = i_h = 0 \right] &= \\
&= [(I_h + Q_h + Q_h^2 + \dots + Q_h^5)H_h]_0 \\
&\quad + \sum_{\alpha_s=0}^{M_s} \sum_{\alpha_d=0}^{M_d} a(1, \alpha_s, \alpha_d) [(I_h + Q_h + Q_h^2 + \dots + Q_h^{T_h})H_h]_1 \\
&\quad + \sum_{\alpha_h=2}^{M_h} \sum_{\alpha_s=0}^{M_s} \sum_{\alpha_d=0}^{M_d} a(\alpha_h, \alpha_s, \alpha_d) [(I_h + Q_h + Q_h^2 + \dots + Q_h^{T_{ch}})H_h]_{\alpha_h} \\
&\quad + \sum_{\alpha_d=0}^{M_d} b(0, 1, \alpha_d) [(I_h + Q_h + Q_h^2 + \dots + Q_h^{T_h})H_h]_0
\end{aligned}$$

$$\begin{aligned}
& + \sum_{\alpha_s=2}^{M_s} \sum_{\alpha_d=0}^{M_d} b(0, \alpha_s, \alpha_d) [(I_h + Q_h + Q_h^2 + \cdots + Q_h^{T_{ch}}) H_h]_0 \\
& + \sum_{\alpha_h=0}^{M_h} c(0; \alpha_h; 0, 1) [(I_h + Q_h + Q_h^2 + \cdots + Q_h^{T_h}) H_h]_0 \\
& + \sum_{\alpha_h=0}^{M_h} \sum_{\alpha_d=2}^{M_d} [c(0; \alpha_h; 0, \alpha_d)] [(I_h + Q_h + Q_h^2 + \cdots + Q_h^{T_{ch}}) H_h]_0 \quad (3.51) \\
& + \sum_{i_s=1}^{M_s} \sum_{k=i_s}^{M_s} [Q_h^{w_m+4}]_{i_s, k} P_{suc}^{(s)}(k) \left[ \left( I_s + \sum_{l=1}^{12+T_s} X_k^l(Q_h) H_h \right) \right]_0 \\
& + \sum_{i_s=1}^{M_s} \sum_{j=i_s}^{M_s} [Q_h^{w_m+4}]_{i_s, k} (1 - P_{suc}^{(s)}(k)) \left[ \left( I_s + \sum_{l=1}^{12+T_{cs}} X_k^l(Q_h) H_h \right) \right]_0 \\
& + \sum_{i_d=1}^{M_d} \sum_{k=i_d}^{M_d} [Q_h^{w_m+8}]_{i_d, k} P_{suc}^{(s)}(k) \left[ \left( I_s + \sum_{l=1}^{16+T_d} Y_k^l(Q_h) H_h \right) \right]_0 \\
& + \sum_{i_d=1}^{M_d} \sum_{k=i_d}^{M_d} [Q_h^{w_m+8}]_{i_d, k} (1 - P_{suc}^{(s)}(k)) \left[ \left( I_s + \sum_{l=1}^{16+T_{cd}} Y_k^l(Q_h) H_h \right) \right]_0
\end{aligned}$$

### Expected Length of a $C_s$ -Cycle

In a manner analogous to that of the high priority method, the expected length of the standard priority's cycle can be found in two cases as follows:

Case 1.  $i_s \neq 0$

$$\begin{aligned}
E & [ t_{p_s}^{(r+1)} - t_{p_s}^{(r)} | m_s(t_{p_s}^{(r)}) = i_s \neq 0 ] \\
& = \sum_{k_s=i_s}^{M_s} [Q_s^{w_m+4}]_{i_s, k_s} \left\{ w_m + 4 + \bar{I}_{k_s} \right. \\
& + P_{suc}^{(s)}(k_s) \left( T_s + 1 + \sum_{n_h=0}^{M_h} [X_{k_s}^{(s)*}(Q_h)]_{0, n_h} \bar{I}_{n_h} \right) \\
& \left. + (1 - P_{suc}^{(s)}(k_s)) \left( T_{cs} + 1 + \sum_{n_h=0}^{M_h} [X_{k_s}^{(f)*}(Q_h)]_{0, n_h} \bar{I}_{n_h} \right) \right\} \quad (3.52)
\end{aligned}$$

Case 2.  $i_s = 0$

$$\begin{aligned}
E & [ t_{p_s}^{(r+1)} - t_{p_s}^{(r)} | m_s(t_{p_s}^{(r)}) = i_s = 0 ] \\
& = w_m + 4 + b(0, 0, 0) \bar{I}_0
\end{aligned}$$

$$\begin{aligned}
& + \sum_{k_h=0}^{M_h} \left\{ \sum_{\alpha_s=0}^{M_s} \sum_{\alpha_d=0}^{M_d} [a(1, \alpha_s, \alpha_d)] [Q_h^{T_h+1} J_h]_{1, k_h} (T_h + \bar{L}_{k_h}) \right. \\
& + \sum_{\alpha_h=2}^k \sum_{\alpha_s=0}^{M_s} \sum_{\alpha_d=0}^{M_d} [a(\alpha_h, \alpha_s, \alpha_d)] [Q_h^{T_{ch}+1}]_{\alpha_h, k_h} (T_{ch} + \bar{L}_{k_h}) \\
& + \sum_{\alpha_d=0}^{M_d} [b(0, 1, \alpha_d)] [Q_h^{T_s+1}]_{0, k_h} (T_s + \bar{L}_{k_h}) \\
& + \sum_{\alpha_s=2}^{M_s} \sum_{\alpha_d=0}^{M_d} [b(0, \alpha_s, \alpha_d)] [Q_h^{T_{cs}+1}]_{0, k_h} (T_{cs} + \bar{L}_{k_h}) \\
& + \sum_{\alpha_h=0}^{M_h} [c(0; \alpha_h; 0, 1)] [Q_h^{T_d+1}]_{\alpha_h, k_h} (T_h + \bar{L}_{k_h}) \\
& + \left. \sum_{\alpha_h=0}^{M_h} \sum_{\alpha_d=2}^{M_d} [c(0; \alpha_h; 0, \alpha_d)] [Q_h^{T_{cd}+1}]_{\alpha_h, k_h} (T_{ch} + \bar{L}_{k_h}) \right\} \\
& + \sum_{j_d=i_d}^{M_d} [Q_s^{w_m+4+4}]_{i_d, j_d} [w_m + 4 + 4 + P_{suc}^{(d)}(j_d)(T_d + 1) \\
& + (1 - P_{suc}^{(d)}(j_d))(T_{cd} + 1)]
\end{aligned} \tag{3.53}$$

where  $b(\alpha_h, \alpha_s, \alpha_d)$  was defined in Eq. (3.17).

### Expected Sum of Standard Priority Backlogs over a $C_s$ -Cycle

The expected sum of the backlog over the cycle can be found in a manner analogous to that of high priority method, and it is provided for 2 cases, when it is given that  $i_s \neq 0$  or that  $i_s = 0$ , respectively.

**Case 1.**  $m_s(t_{ps}^{(r)}) = i_s \neq 0$

$$\begin{aligned}
& E \left[ \sum_{t=t_{ps}^{(r)}}^{t_{ps}^{(r+1)}-1} m_s(t) \mid m_s(t_{ps}^{(r)}) = i_s \neq 0 \right] = \\
& = [(I_s + Q_s + Q_s^2 + \dots + Q_s^{w_m+3}) H_s]_{i_s} \\
& + \sum_{k_s=i_s}^{M_s} [Q_s^{w_m+4}]_{i_s, k_s} k_s \bar{L}_{k_s} \\
& + \sum_{k_s=i_s}^{M_s} [Q_s^{w_m+4}]_{i_s, k_s} \left[ S_s (I_s + Q_s + Q_s^2 + \dots + Q_s^{T_s+1}) H_s \right.
\end{aligned}$$

$$\begin{aligned}
& + F_s(I_s + Q_s + Q_s^2 + \dots + Q_s^{T_{cs}+1})H_s \\
& + S_s Q_s^{T_s+1} \left( I_s + \sum_{l=1}^{12+T_s} \sum_{n_h=0}^{M_h} [X_{k_s}^{l*}(Q_h)]_{0,n_h} L_{n_h}^*(Q_s) \right) H_s \\
& + F_s Q_s^{T_s+1} \left( I_s + \sum_{l=1}^{12+T_{cs}} \sum_{n_h=0}^{M_h} [X_{k_s}^{l*}(Q_h)]_{0,n_h} L_{n_h}^*(Q_s) \right) H_s \Big]_{k_s}
\end{aligned} \tag{3.54}$$

Case 2.  $m_s(t_{ps}^{(r)}) = i_s = 0$

$$\begin{aligned}
& E \left[ \sum_{t=t_{ps}^{(r)}}^{t_{ps}^{(r+1)}-1} m_s(t) \mid m_s(t_{ps}^{(r)}) = i_s = 0 \right] = \\
& = [(I_s + Q_s + Q_s^2 + \dots + Q_s^{w_m+3})H_s]_0 \\
& + \sum_{\alpha_s=0}^{M_s} \sum_{\alpha_d=0}^{M_d} a(1, \alpha_s, \alpha_d) \left[ \left( I_s + \sum_{n_h=0}^{M_h} [Q_h^1 J_h]_{1,n_h} Q_s L_{n_h}^*(Q_s) \right. \right. \\
& + \dots + \left. \left. \sum_{n_h=0}^{M_h} [Q_h^{T_h} J_h]_{1,n_h} Q_s^{T_h} L_{n_h}^*(Q_s) \right) H_s \right]_0 \\
& + \sum_{\alpha_h=2}^{M_h} \sum_{\alpha_s=0}^{M_s} \sum_{\alpha_d=0}^{M_d} a(\alpha_h, \alpha_s, \alpha_d) \left[ \left( I_s + \sum_{n_h=\alpha_h}^{M_h} [Q_h^1]_{\alpha_h,n_h} Q_s^1 L_{n_h}^*(Q_s) \right. \right. \\
& + \dots + \left. \left. \sum_{n_h=\alpha_h}^{M_h} [Q_h^{T_{ch}}]_{\alpha_h,n_h} Q_s^{T_{ch}} L_{n_h}^*(Q_s) \right) H_s \right]_0 \\
& + \sum_{\alpha_d=0}^{M_d} b(0, 1, \alpha_d) \left[ \left( I_s + \sum_{n_h=0}^{M_h} [Q_h^1]_{0,n_h} Q_s^1 L_{n_h}^*(Q_s) \right. \right. \\
& + \dots + \left. \left. \sum_{n_h=0}^{M_h} [Q_h^{T_s+1}]_{0,n_h} Q_s^{T_s+1} L_{n_h}^*(Q_s) \right) H_s \right]_1 \\
& + \sum_{\alpha_s=2}^{M_s} \sum_{\alpha_d=0}^{M_d} b(0, \alpha_s, \alpha_d) \left[ \left( I_s + \sum_{n_h=0}^{M_h} [Q_h^1]_{0,n_h} Q_s^1 L_{n_h}^*(Q_s) \right. \right. \\
& + \dots + \left. \left. \sum_{n_h=0}^{M_h} [Q_h^{T_{cs}+1}]_{0,n_h} Q_s^{T_{cs}+1} L_{n_h}^*(Q_s) \right) H_s \right]_{\alpha_s} \\
& + \sum_{\alpha_h=0}^{M_h} [c(0; \alpha_h; 0, 1)] \left[ \left( I_s + \sum_{n_h=0}^{M_h} [Q_h^1]_{0,n_h} Q_s^1 L_{n_h}^*(Q_s) \right. \right. \\
& + \dots + \left. \left. \sum_{n_h=0}^{M_h} [Q_h^{T_d+1}]_{0,n_h} Q_s^{T_d+1} L_{n_h}^*(Q_s) \right) H_s \right]_0 \\
& + \sum_{\alpha_h=0}^{M_h} \sum_{\alpha_d=2}^{M_d} [c(0; \alpha_h; 0, \alpha_d)] \left[ \left( I_s + \sum_{n_h=0}^{M_h} [Q_h^1]_{0,n_h} Q_s^1 L_{n_h}^*(Q_s) \right. \right.
\end{aligned}$$

$$\begin{aligned}
& + \cdots + \sum_{n_h=0}^{M_h} [Q_h^{T_{cd}+1}]_{0,n_h} Q_s^{T_{cd}+1} L_{n_h}^*(Q_s) H_s]_0 \quad (3.55) \\
& + \sum_{i_d=1}^{M_d} \sum_{j=i_d}^{M_d} [Q_h^{w_m+8}]_{i_d,j} P_{suc}^{(s)}(j) \left[ \left( I_s + \sum_{l=1}^{16+T_d} Y_j^l(Q_s) \right) H_s \right]_0 \\
& + \sum_{i_d=1}^{M_d} \sum_{j=i_d}^{M_d} [Q_h^{w_m+8}]_{i_d,j} (1 - P_{suc}^{(s)}(j)) \left[ \left( I_s + \sum_{l=1}^{16+T_{cd}} Y_j^l(Q_s) \right) H_s \right]_0
\end{aligned}$$

### Expected Length of a $C_d$ -Cycle

Case 1.  $i_d \neq 0$

$$\begin{aligned}
E \quad & [ t_{p_d}^{(\tau+1)} - t_{p_d}^{(\tau)} | m_d(t_{p_d}^{(\tau)}) = i_d \neq 0 ] = \\
& = \sum_{k_s=i_d}^{M_d} [Q_d^{w_m+4+4}]_{i_d,k_d} \left\{ w_m + 4 + 4 + \bar{I}_{k_d} \right. \\
& + P_s^{(d)}(k_d) \left( T_d + 1 + \sum_{n_h=0}^{M_h} [Y_{k_d}^{(s)*}(Q_h)]_{0,n_h} \sum_{n_s=0}^{M_s} [Y_{k_d}^{(s)*}(Q_s)]_{0,n_s} \bar{L}_{n_h,n_s} \right) \\
& \left. + (1 - P_s^{(d)}(k_d)) \left( T_{cd} + 1 + \sum_{n_h=0}^{M_h} [Y_{k_d}^{(f)*}(Q_h)]_{0,n_h} \sum_{n_s=0}^{M_s} [Y_{k_d}^{(f)*}(Q_s)]_{0,n_s} \bar{L}_{n_h,n_s} \right) \right\} \quad (3.56)
\end{aligned}$$

Case 2.  $i_d = m_d(t_{p_d}^{(\tau)}) = 0$

$$\begin{aligned}
E \quad & [ t_{p_d}^{(\tau+1)} - t_{p_d}^{(\tau)} | m_d(t_{p_d}^{(\tau)}) = i_d = 0 ] = \\
& = w_m + 4 + 4 + \\
& + [C_{w_m+A_h+A_s}(0; 0; 0, 0)] \bar{I}_0 \\
& + \sum_{n_h=0}^{M_h} \sum_{n_s=0}^{M_s} \left\{ \sum_{\alpha_s=0}^{M_s} \sum_{\alpha_d=0}^{M_d} [a(1, \alpha_s, \alpha_d)] [Q_h^{T_h+1} J_h]_{1,n_h} [Q_s^{T_h+1}]_{\alpha_s,n_s} (T_h + \bar{L}_{n_h,n_s}) \right. \\
& + \sum_{\alpha_h=2}^k \sum_{\alpha_s=0}^{M_s} \sum_{\alpha_d=0}^{M_d} [a(\alpha_h, \alpha_s, \alpha_d)] [Q_h^{T_{ch}+1}]_{\alpha_h,n_h} [Q_s^{T_{ch}+1}]_{\alpha_s,n_s} (T_{ch} + \bar{L}_{n_h,n_s}) \\
& + \sum_{\alpha_d=0}^{M_d} [b(0, 1, \alpha_d)] [Q_h^{T_s+1}]_{0,n_h} [Q_s^{T_s+1} J_s]_{1,n_s} (T_s + \bar{L}_{n_h,n_s}) \\
& + \sum_{\alpha_s=2}^{M_s} \sum_{\alpha_d=0}^{M_d} [b(0, \alpha_s, \alpha_d)] [Q_h^{T_{cs}+1}]_{0,n_h} [Q_s^{T_{cs}+1}]_{\alpha_s,n_s} (T_{cs} + \bar{L}_{n_h,n_s}) \\
& \left. + \sum_{\alpha_h=0}^{M_h} [c(0; \alpha_h; 0, 1)] [Q_h^{T_d+1}]_{\alpha_h,n_h} [Q_s^{T_d+1}]_{0,n_s} (T_d + \bar{L}_{n_h,n_s}) \right\} \quad (3.57)
\end{aligned}$$

$$+ \sum_{\alpha_h=0}^{M_h} \sum_{\alpha_d=2}^{M_d} c(0; \alpha_h; 0, \alpha_d) [Q_h^{T_{cd}+1}]_{\alpha_h, n_h} [Q_s^{T_{cd}+1}]_{0, n_s} (T_{cd} + \bar{L}_{n_h, n_s}) \}$$

where

$$c(0; \alpha_h; 0, 1) = [Q_h^{w_m+4}]_{0,0} [Q_h^4]_{0,\alpha_h} [Q_s^{w_m+4+4}]_{0,0} [Q_d^{w_m+4+4}]_{0,1} \quad (3.58)$$

$$c(0; \alpha_h; 0, \alpha_d) = [Q_h^{w_m+4}]_{0,0} [Q_h^4]_{0,\alpha_h} [Q_s^{w_m+4+4}]_{0,0} [Q_d^{w_m+4+4}]_{0,\alpha_d} \quad (3.59)$$

### Expected Sum of Deferred Priority Backlogs over a $C_d$ -Cycle

Case 1.  $m_d(t_{pd}^{(r)}) = i_d \neq 0$

$$\begin{aligned} E \left[ \sum_{t=t_{pd}^{(r)}}^{t_{pd}^{(r+1)}-1} m_d(t) \mid m_d(t_{pd}^{(r)}) = i_d \neq 0 \right] \\ = & [(I_d + Q_d + Q_d^2 + \dots + Q_d^{w_m+7}) H_d]_{i_d} \\ & + \sum_{k_d=i_d}^{M_d} [Q_d^{w_m+4+4}]_{i_d, k_d} k_d \bar{I}_{k_d} \\ & + \sum_{k_d=i_d}^{M_d} [Q_d^{w_m+4+4}]_{i_d, k_d} \left[ S_d (I_d + Q_d + Q_d^2 + \dots + Q_d^{T_d}) H_d \right]_{i_d} \\ & + [F_d (I_d + Q_d + Q_d^2 + \dots + Q_d^{T_d}) H_d]_{i_d} \\ & + S_d Q_d^{T_d+1} \left( I_d + \sum_{l=1}^{16+T_d} \sum_{n_h=0}^{M_h} [Y_{k_d}^{l*}(Q_h)]_{0, n_h} \right. \\ & \quad \cdot \sum_{n_s=0}^{M_s} [Y_{k_d}^{l*}(Q_s)]_{0, n_s} L_{n_h, n_s}^*(Q_d) \left. \right) H_d \\ & + F_d Q_d^{T_{cd}+1} \left( I_d + \sum_{l=1}^{16+T_{cd}} \sum_{n_h=0}^{M_h} [Y_k^{l*}(Q_h)]_{0, n_h} \right. \\ & \quad \cdot \sum_{n_s=0}^{M_s} [Y_{k_d}^{l*}(Q_s)]_{0, n_s} L_{n_h, n_s}^*(Q_d) \left. \right) H_d \Big]_{k_d} \quad (3.60) \end{aligned}$$

Case 2.  $m_d(t_{pd}^{(r)}) = i_d = 0$

$$E \left[ \sum_{t=t_{pd}^{(r)}}^{t_{pd}^{(r+1)}-1} m_d(t) \mid m_d(t_{pd}^{(r)}) = i_d = 0 \right]$$

$$\begin{aligned}
&= [(I_d + Q_d + Q_d^2 + \cdots + Q_d^{w_m+7})H_d]_0 \\
&+ \sum_{\alpha_s=0}^{M_s} \sum_{\alpha_d=0}^{M_d} a(1, \alpha_s, \alpha_d) \left[ \left( I_s + \sum_{n_h=0}^{M_h} [Q_h^1 J_h]_{1, n_h} \sum_{n_s=\alpha_s}^{M_s} [Q_s^1]_{\alpha_s, n_s} Q_s^1 L_{n_h, n_s}^*(Q_s) \right. \right. \\
&+ \cdots + \left. \sum_{n_h=0}^{M_h} [Q_h^{T_h} J_h]_{1, n_h} \sum_{n_s=\alpha_s}^{M_s} [Q_s^{T_h}]_{\alpha_s, n_s} Q_s^{T_h} L_{n_h, n_s}^*(Q_s) \right) H_s \Big]_0 \\
&+ \sum_{\alpha_h=2}^{M_h} \sum_{\alpha_s=0}^{M_s} \sum_{\alpha_d=0}^{M_d} a(\alpha_h, \alpha_s, \alpha_d) \left[ \left( I_s + \sum_{n_h=\alpha_h}^{M_h} [Q_h^1]_{\alpha_h, n_h} \sum_{n_s=\alpha_s}^{M_s} [Q_s^1]_{\alpha_s, n_s} Q_d^1 L_{n_h, n_s}^*(Q_s) \right. \right. \\
&+ \cdots + \left. \sum_{n_h=\alpha_h}^{M_h} [Q_H^{T_{ch}}]_{\alpha_h, n_h} \sum_{n_s=\alpha_s}^{M_s} [Q_s^{ch}]_{\alpha_s, n_s} Q_d^{T_{ch}} L_{n_h, n_s}^*(Q_s) \right) H_s \Big]_0 \\
&+ \sum_{\alpha_d=0}^{M_d} b(0, 1, \alpha_d) \left[ \left( I_s + \sum_{n_h=0}^{M_h} [Q_h^1]_{0, n_h} \sum_{n_s=\alpha_s}^{M_s} [Q_s^1 J_s]_{1, n_s} Q_d^1 L_{n_h, n_s}^*(Q_s) \right. \right. \\
&+ \cdots + \left. \sum_{n_h=0}^{M_h} [Q_h^{T_s}]_{0, n_h} \sum_{n_s=\alpha_s}^{M_s} [Q_s^{T_s}]_{\alpha_s, n_s} Q_d^{T_s} L_{n_h, n_s}^*(Q_s) \right) H_s \Big]_0 \\
&+ \sum_{\alpha_s=2}^{M_s} \sum_{\alpha_d=0}^{M_d} b(0, \alpha_s, \alpha_d) \left[ \left( I_s + \sum_{n_h=0}^{M_h} [Q_h^1]_{0, n_h} \sum_{n_s=\alpha_s}^{M_s} [Q_s^1]_{\alpha_s, n_s} Q_d^1 L_{n_h, n_s}^*(Q_s) \right. \right. \\
&+ \cdots + \left. \sum_{n_h=0}^{M_h} [Q_h^{T_{cs}}]_{0, n_h} \sum_{n_s=\alpha_s}^{M_s} [Q_s^{T_{cs}}]_{\alpha_s, n_s} Q_s^{T_{cs}} L_{n_h, n_s}^*(Q_s) \right) H_s \Big]_0 \tag{3.61} \\
&+ \sum_{\alpha_h=0}^{M_h} c(0; \alpha_h; 0, 1) \left[ \left( I_d + \sum_{n_h=\alpha_h}^{M_h} \sum_{n_s=0}^{M_s} [Q_h^1]_{\alpha_h, n_h} [Q_s^1]_{0, n_s} Q_d^1 L_{n_h, n_s}^*(Q_d) \right) H_s \right]_1 \\
&+ \cdots + \sum_{n_h=\alpha_h}^{M_h} \sum_{n_s=0}^{M_s} [Q_h^{T_d}]_{\alpha_h, n_h} [Q_s^{T_d}]_{0, n_s} Q_d^{T_d} L_{n_h, n_s}^*(Q_d) \Big]_1 \\
&+ \sum_{\alpha_h=0}^{M_h} \sum_{\alpha_d=2}^{M_d} c(0; \alpha_h; 0, \alpha_d) \left[ \left( I_d + \sum_{n_h=\alpha_h}^{M_h} \sum_{n_s=0}^{M_s} [Q_h^1]_{\alpha_h, n_h} [Q_s^1]_{0, n_s} Q_d^1 L_{n_h, n_s}^*(Q_d) \right) H_s \right]_{\alpha_d} \\
&+ \cdots + \sum_{n_h=\alpha_h}^{M_h} \sum_{n_s=0}^{M_s} [Q_h^{T_{cd}}]_{\alpha_h, n_h} [Q_s^{T_{cd}}]_{0, n_s} Q_d^{T_{cd}} L_{n_h, n_s}^*(Q_d) \Big]_{\alpha_d}
\end{aligned}$$

### 3.2.4 Throughput and Delay Performance

Given the network model which is a priority channel assigned multiple access and priority reservation at embedded points (at the end of EOP) scheme, the quantities



of the ergodic Markov chain [17], [18] can be determined from

$$1 = \sum_{j=0}^{\infty} \pi_j$$

and

$$\pi_i^{(p)} = \sum_{j=0}^{\infty} \pi_j^{(p)} [P_p]_{j,i} \quad (3.62)$$

If we denote the steady state probability distribution of  $m_p(t_p)$  at the embedded points as  $\vec{\Pi} = [\pi_0, \pi_1, \dots, \pi_{M_p}]$ ,  $\vec{\Pi}$  can be evaluated by the recursive method of  $\vec{\Pi} = \vec{\Pi}P$ . Here  $\vec{\Pi}$  is an  $(M_p + 1)$ -dimensional row vector, and matrix  $P$  is an  $(M_p + 1) \times (M_p + 1)$  matrix, where each of its elements is also an  $(M_p + 1) \times (M_p + 1)$  matrix for each priority. Let  $P_{su}^{(p)}(i)$  denote the probability of a successful transmission during a  $C_p$ -cycle in a given  $m_p(t_p^{(\tau)}) = i$ .

$$P_{su}^{(h)}(0) = \sum_{\alpha_s=0}^{M_s} \sum_{\alpha_d=0}^{M_d} [Q_h^{w_m}]_{0,1} [Q_s^{w_m}]_{0,\alpha_s} [Q_d^{w_m}]_{0,\alpha_d} \quad i_h = 0 \quad (3.63)$$

$$P_{su}^{(s)}(0) = \sum_{\alpha_d=0}^{M_d} [Q_h^{w_m+4}]_{0,0} [Q_s^{w_m+4}]_{0,1} [Q_d^{w_m+4}]_{0,\alpha_d} \quad i_s = 0 \quad (3.64)$$

$$P_{su}^{(d)}(0) = \sum_{\alpha_h=0}^{M_h} [Q_h^{w_m+4}]_{0,0} [Q_h^4]_{0,\alpha_h} [Q_s^{w_m+8}]_{0,0} [Q_d^{w_m+8}]_{0,1} \quad i_d = 0 \quad (3.65)$$

$$P_{su}^{(h)}(i_h) = \sum_{k_h=i_h}^{M_h} [Q_h^{w_m}]_{i_h,k_h} P_{suc}^{(h)}(k_h) \quad i_h \neq 0 \quad (3.66)$$

$$P_{su}^{(s)}(i_s) = \sum_{k_s=i_s}^{M_s} [Q_s^{w_m+4}]_{i_s,k_s} P_{suc}^{(s)}(k_s) \quad i_s \neq 0 \quad (3.67)$$

$$P_{su}^{(d)}(i_d) = \sum_{k_d=i_d}^{M_d} [Q_h^{w_m+8}]_{i_d,k_d} P_{suc}^{(d)}(k_d) \quad i_d \neq 0 \quad (3.68)$$

Here  $P_{su}^{(p)}(k)$  is the probability of a successful transmission in a cycle given that  $m_p(t_p) = k$ . It is expressed as

$$P_{su}^{(p)}(k) = \frac{a_i^{(p)}(0)b_i^{(p)}(1) + a_i^{(p)}(1)b_i^{(p)}(0)}{1 - d_k^{(p)}} \quad (3.69)$$

Since  $m_p(t_p)$  is a regenerative process, the average steady state channel throughput  $S_p$  and the average channel backlog  $\bar{N}_p$  of each priority, as noted in [59], are given by

$$S_p = \frac{\sum_{i=0}^{M_p} \sum_{j=0}^{M_p} \pi_j^{(p)} [P_p]_{j,i} P_{su}^{(p)}(i) T_p}{\sum_{i=0}^{M_p} \pi_i^{(p)} E[t_p^{(r+1)} - t_p^{(r)} | m_p(t_p^{(r)}) = i]} \quad (3.70)$$

$$\bar{N}_p = \frac{\sum_{i=0}^{M_p} \pi_i^{(p)} E\left[\sum_{t=t_p^{(r)}}^{t_p^{(r+1)}-1} m_p(t) | m_p(t_p^{(r)}) = i\right]}{\sum_{i=0}^{M_p} \pi_i^{(p)} E[t_p^{(r+1)} - t_p^{(r)} | m_p(t_p^{(r)}) = i]} \quad (3.71)$$

Let  $\mathbf{S}$  denote the ratio of the average time that the channel is carrying  $C_p$ -successful-transmissions over the  $C_p$ -cycle to the average length of that period.  $\bar{N}$  is the average ratio of the sum of backlogs over all slots in a priority  $C_p$ -cycle to the length in slots of that period. Therefore total average steady state channel throughput  $\mathbf{S}$  and average channel backlog  $\bar{N}$  of the 3 priorities are given by

$$S = S_h + S_s + S_d \quad (3.72)$$

$$\bar{N} = \bar{N}_h + \bar{N}_s + \bar{N}_d \quad (3.73)$$

By Little's result [75], the average delay of each priority (normalized with respect to packet length  $T_p$ ) is simply

$$D_p = \frac{\bar{N}_p}{S_p} \quad (3.74)$$

### 3.3 Numerical Analysis and Discussion

In this section, numerical analysis for priority contention resolution in priority channel assigned multiple access is provided. Moreover, a comparison of performance of

throughput and delay is shown for both theoretical analyses and simulation experiments.

It is difficult to evaluate the effect that several parameters have simultaneously on a system's performance. Let us assume that the number of stations for each priority is 5, thus making the total number of stations equal to 15. In this chapter, we focus on numerical results pertaining to the priority function and the effect of various system parameters on its performance. The packet lengths for all priorities are equal to each other, i.e.,  $T_h = T_s = T_d = T$ . The values employed for the packet length are either 50, 200, 300, 500, or 1,000 bits. The value of  $\nu_p$  for the persistent protocol is chosen as 0.25 to represent a random start time between 0 and 3 (use of one out of a total of 4 time slots). The values of 0.125 and 0.5 were utilized as well in order to study the sensitivity of packet throughput and delay to  $\nu_p$ .  $T_{cp}$  is assumed to be 2 bits, and it denotes the collision detection time required.

The channel access scheme proposed incorporates a priority mechanism with a different time assignment according to each priority and a  $P$ -persistent procedure with parameter  $\nu_p$  for each priority.

Any possible limitations on some aspects of the model, in theoretical analysis, such as the random start delay within 4 bits, contention resolution during the preamble field of 8 bits, and the queueing state of each node are handled by simulation experiments. For consistent comparisons, it is assumed for both the numerical analysis and simulation experiments to take 1 slot (UST) to transmit 1 bit length. Actual values may be calculated by multiplying 1.5 times the results of the values. It is found that the simulation experiments verify the results obtained in the mathematical model closely, which further validates the simulation model itself.

The simulator employed for system and protocol modeling in these experiments was written in C language using the C-Library functions provided by LANSF [83]. The network configuration is specified in a data file which is interpreted by the simu-

Table 3.1: Example of Parameters and Numerical Values

$T_p$ bits	$\lambda_p$ Packet/sec	$\lambda_M$ Packet/sec	$G$ (Norm.)	$g_p$ (Norm.)	Delay(Analysis)			Delay(Simulation)		
					HI	ST	DE	HI	ST	DE
200	16.67	50	1.0	0.00033	347	1740	11500	330	640	7700
200	50	150	3.0	0.001	930	800K	$\infty$	800	120K	$\infty$

HI=HIGH, ST=STANDARD, and DE=DEFERRED for packet delay in slots. Norm. indicates "normalized".

lation facility. The programming interface to LANSF is UNIX/C. For the numerical analysis, the mathematical development was written in C and the program ran in the UNIX system.

The *channel throughput* calculated in the simulation is measured as the ratio of the total number of information bits successfully transmitted through the link to the simulation time. The *average packet delay*  $D$  in the theoretical analysis as well as the simulation experiments is defined as the average time incurred from when a packet is ready to be transmitted until it is successfully received. Delay  $D$  of the theoretical analysis is denormalized to packet length  $T$  for consistent comparison with simulation results. In order to investigate total or message delay which includes queueing delay at the buffer, two types of delay, i.e., packet and message delay are studied and compared by simulation. Here *packet delay* was measured as the time elapsing from the moment the packet became ready to be transmitted to the moment the entire packet was successfully received at its destination, and *message delay* was measured as the time elapsing from the moment the message was queued in the buffer at the sending node to the moment the entire message is successfully received at the destination including the message queueing time.

The parameter  $g_p$  is the new arrival rate per user in a slot for priority  $p$ ; it relates to total offered load  $G$ . The latter is normalized to the channel capacity as follows:

$$G = \frac{\lambda_h T_h + \lambda_s T_s + \lambda_d T_d}{c} = \frac{\lambda_M T}{c} \quad (3.75)$$

where the parameter  $\lambda_p$  (here  $p$  denotes one of the 3 priorities) characterizes the

Poisson distribution describing the arrival of messages. We may write

$$\lambda_M = \lambda_h + \lambda_s + \lambda_d = 3\lambda \text{ [pkt/sec]} \quad (3.76)$$

where it is assumed that

$$\lambda_h = \lambda_s = \lambda_d = \lambda \quad (3.77)$$

It is further assumed that all packet lengths are equal, i.e.,  $T_h = T_s = T_d = T$  [bits]. Let  $c$  be the channel capacity or data rate in bits/sec. From Eq. (3.75),

$$\begin{aligned} \lambda &= \frac{1}{3} \frac{cG}{T} \text{ [pkt/sec]} \\ g_p &= \frac{\lambda}{M_p} \frac{1}{c} = \frac{G}{3M_p T} \text{ [pkt/slot]} \end{aligned} \quad (3.78)$$

Here  $M_p$  denotes the number of stations of priority  $p$  and  $M_p = M_h = M_s = M_d = 5$ , thus the total number of stations is 15. An example of numerical values is shown in Table 3.1.

Both numerical and simulation studies of throughput and delay have been carried out and the results have been plotted. Heavy as well as light loads have been used. Light load is defined as a network loading level in which any station ready for packet transmission will find the bus idle with a very high probability (i.e., with probability  $\approx 1$ ). Thus under very light loads, an idle station upon changing to ready can start its packet transmission immediately. By contrast heavy loads result in a lot of contention.

In examining the results, shown in Figs. 3.6 and 3.7, we find that at light loads the numerical results for throughput are almost identical to and just slightly higher than the experimental results. The latter is due to persistent channel access in the theoretical model as compared to the utilization of a random start time in the simulation experiments.

Under heavy traffic load, the numerical analysis shows a slightly lower throughput than that of the simulation experiments. The reason is that during the priority channel access (PCA) of 4 USTs (time slots) the theoretical algorithm (PAMA/PR)

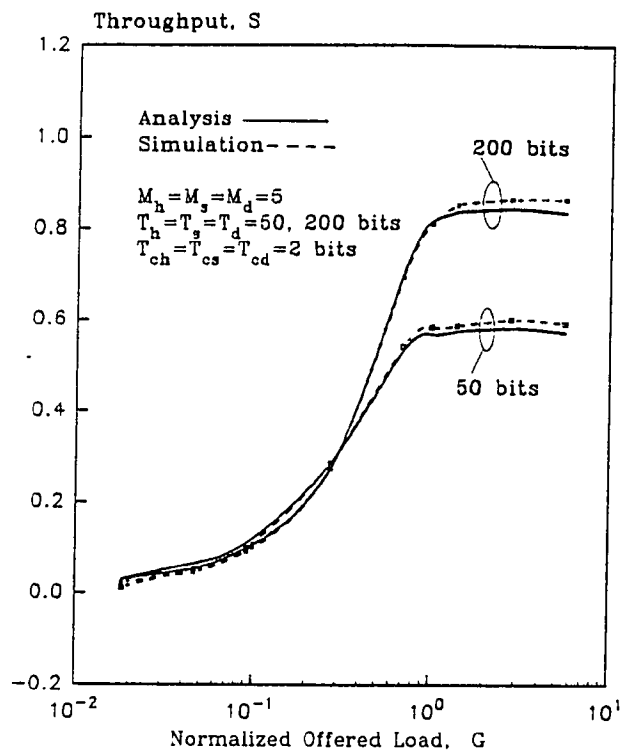

Fig. 3.6 Comparisons of Throughput by Numerical Analysis and Simulation as a Function of Offered Load when Packet Lengths are 50, 200 bits, respectively.

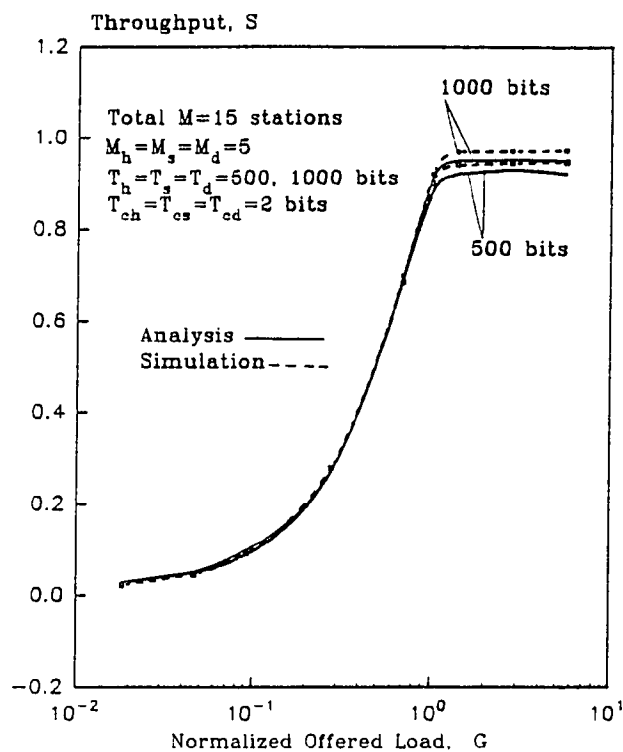

Fig. 3.7 Comparisons of Throughput by Numerical Analysis and Simulation as a Function of Offered Load when Packet Lengths are 500, 1000 bits, respectively.

starts the transmission with probability  $P$  for each priority while the simulation experiment employs random start delay among 4 USTs. In addition, while the theoretical analysis includes minimum wait time for channel access of 6 slots, priority channel access, and persistent transmission compatible to random start time, the simulation experiments while incorporating all the PAMA/PR already plus the CEBus contention resolution scheme during the 8 bits of the preamble field and the effect of queueing state (queued or unqueued) of the station. The contention, even after going through the priority channel access assignment and random start transmission phases of the protocol unsuccessfully could still be resolved during the preamble field of 8 bits in the CEBus protocol, which is carried out in the simulation, but not in the analysis.

In Fig. 3.6 the maximum achievable throughput in the simulation is 0.6 when the packet length is 50 bits, whereas the theoretical analysis shows a slightly lower value than that of the simulation due to more collisions and retransmissions in the theory than in the simulation models under heavy traffic load. The throughput of the theoretical analysis, when the packet length is equal to 200 bits, achieves maximum value 0.83 while the simulation result is 0.87, indeed quite close. In Figs. 3.6 and Fig. 3.7 it is shown that the maximum value of the throughput increases with packet size. This dependence is strong for small values of packet size as seen in the large increase from size 50 to 200 bits but saturates at a size of about 1,000 bits. In the study of throughput,

It should be noted that theory and experiment are in fairly close agreement. The difference in maximum achievable throughput in all four curves between theory and experiment is less than approximately 5% while analysis consistently underestimates the experimental result.

Maximum achievable throughput overall was observed to be 0.95 approximately through the simulation. Even if we increase the packet size more, the throughput

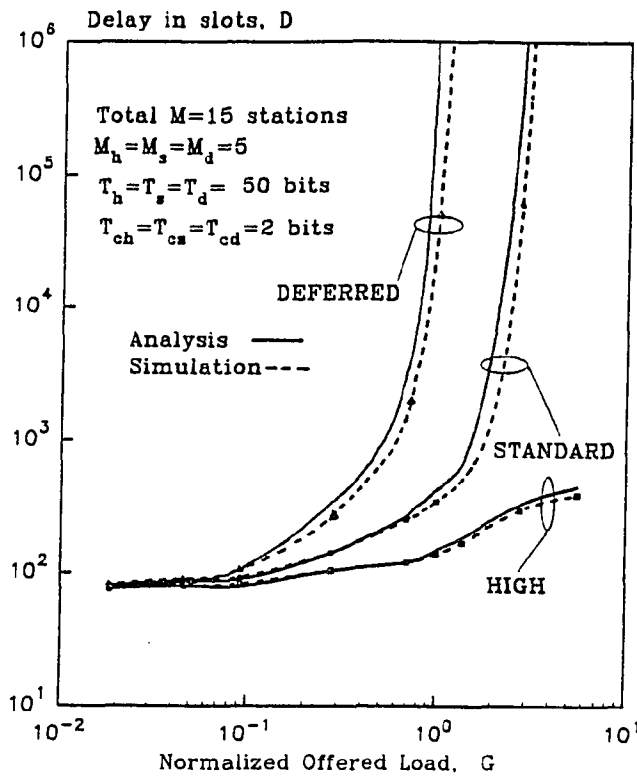

Fig. 3.8 Comparisons of Delays by Numerical Analysis and Simulation as a Function of Offered Load when Packet Length is 50 bits.

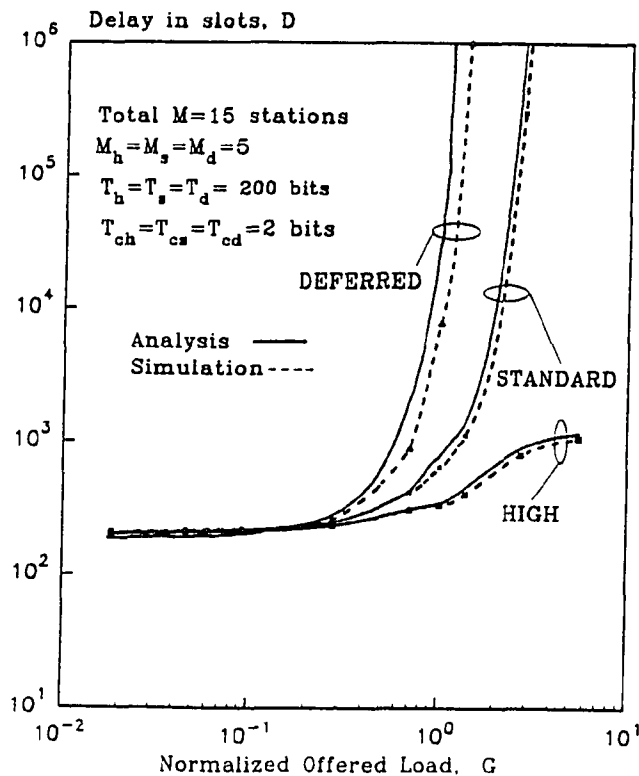

Fig. 3.9 Comparisons of Delays by Numerical Analysis and Simulation as a Function of Offered Load when Packet Length is 200 bits.



hardly increases at all. The throughput increases linearly with load in general until the offered load reaches 0.8, approximately, if the packet length is larger than 200 bits. As the packet length increases, the achievable maximum throughput also becomes larger due to the smaller number of channel access contention instances, for a given throughput resulting from the larger packet length.

Figs. 3.8 – 3.11 show the result for delay vs offered load for the 3 priorities with packet length values of 50, 200, 500, and 1,000 bits, respectively. Delay increases as the packet size becomes larger. The increase in the delay  $D$  is greater initially as packet length  $T$  increases. In Fig. 3.8, as soon as the offered load exceeds 0.1 the delay for the DEFERRED priority increases sharply, while for STANDARD priority rapid increases in delay occur much later and for HIGH delay increases are very small and occur later yet only a little.

Overall there is good agreement between theory and experiment on the resultant delays for the 3 priorities. For load values  $G \leq 0.8$  the difference in results for delay between analysis and simulation are insignificant, less than 2%. At high values of normalized offered load,  $G > 0.8$ , the discrepancy is small, about 5%. Therefore, it may be concluded that theory and experiment are in good agreement in the results for delay for the 3 priorities, as seen in Figs. 3.8 - 3.11. This is combined with the equally good agreement found for throughput, as seen in Figs. 3.6 -3.7 if may be surmised that all the theoretical analysis and the simulation experiment results for the 3 priorities support each other and vouch for each other's validity.

The curves of the numerical analysis manifest a somewhat larger delay than that of simulation experiments as the traffic load increases. This is due to the more frequent retransmissions in the theoretical analysis in comparison with those in the simulation experiments. In the latter the protocol is fine tuned for collision avoidance to a greater degree using the random start access and queueing state of the node as the traffic increases.

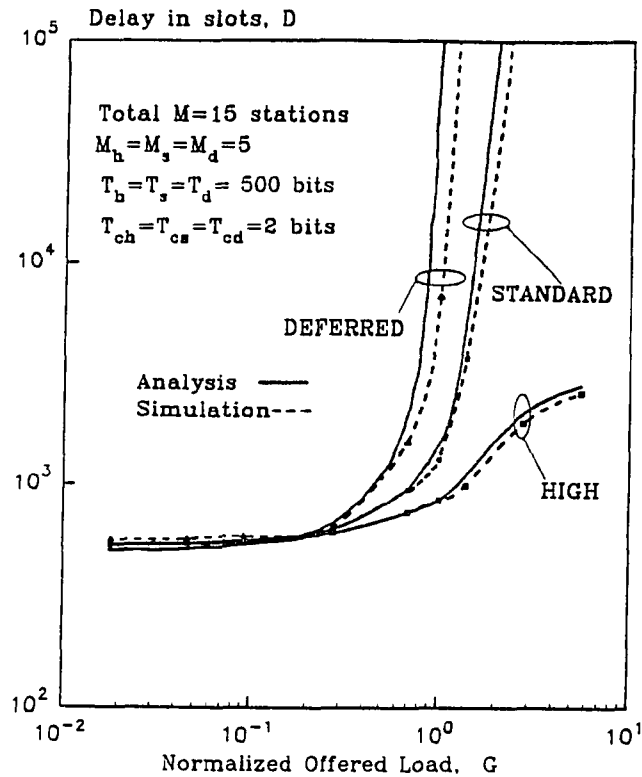

Fig. 3.10 Comparisons of Delay by Numerical Analysis and Simulation as a Function of Offered Load when Packet Length is 500 bits.

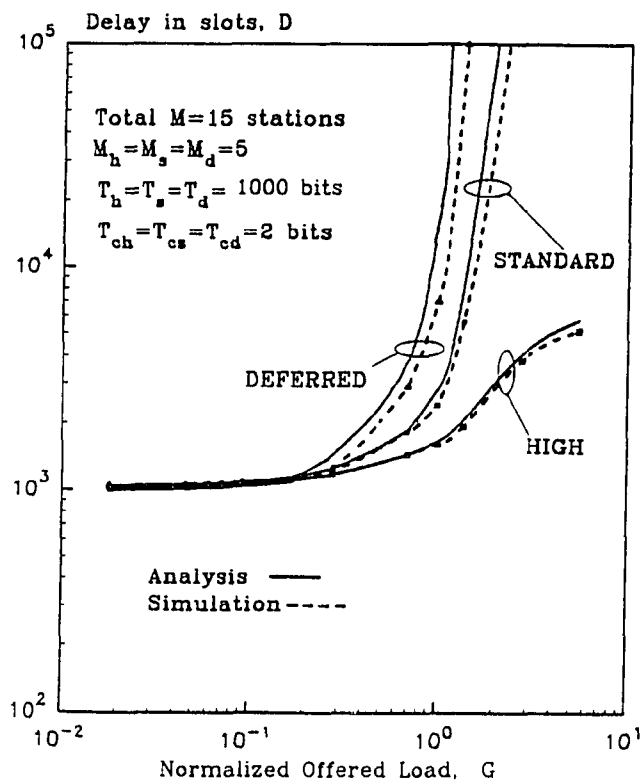

Fig. 3.11 Comparisons of Delay by Numerical Analysis and Simulations as a Function of Offered Load when Packet Length is 1000 bits.

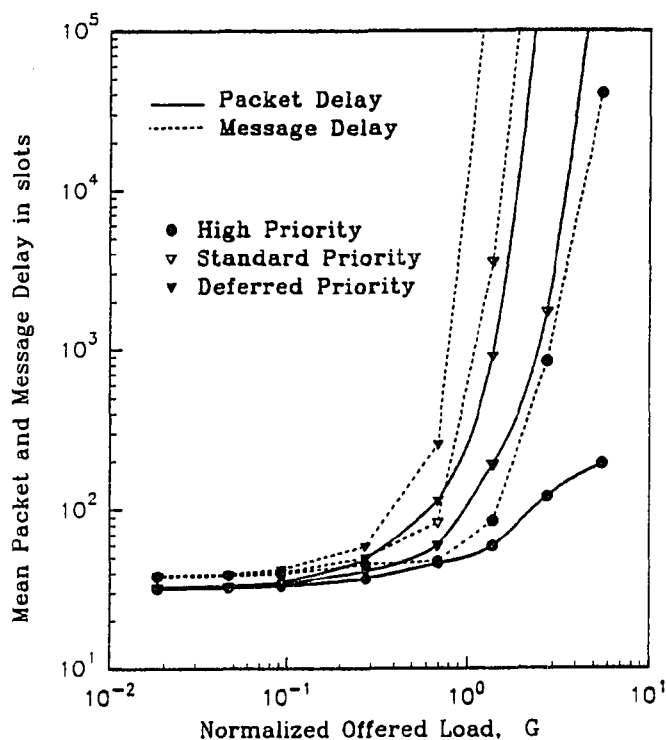

Fig. 3.12 Delay in slots as a Function of Packet Size.

Fig. 3.9 also shows packet delay as a function of the offered load when the packet length utilized is 200 bits. When the offered load exceeds approximately 30% of the network capacity the delay of each priority starts to increase with different rate, and when the load reaches 60% of the network capacity, the DEFERRED priority delay increases dramatically, STANDARD increases moderately, and HIGH only slightly. At more than 80% of channel capacity, DEFERRED priority message transmission effectively cuts out due to continuous deference to higher priority.

Figs. 3.10 and 3.11 also exhibit packet delay performance with packet length 500, and 1,000 bits, respectively. In both figures, as the traffic load increases mathematical model analyses show larger delays than those of the simulation. In light load analysis results of each priority displays the same or slightly smaller delays than those of simulation experiments. This is most likely due to the use of the persistent channel access scheme in analysis instead of random start delay up to 4 USTs along with an

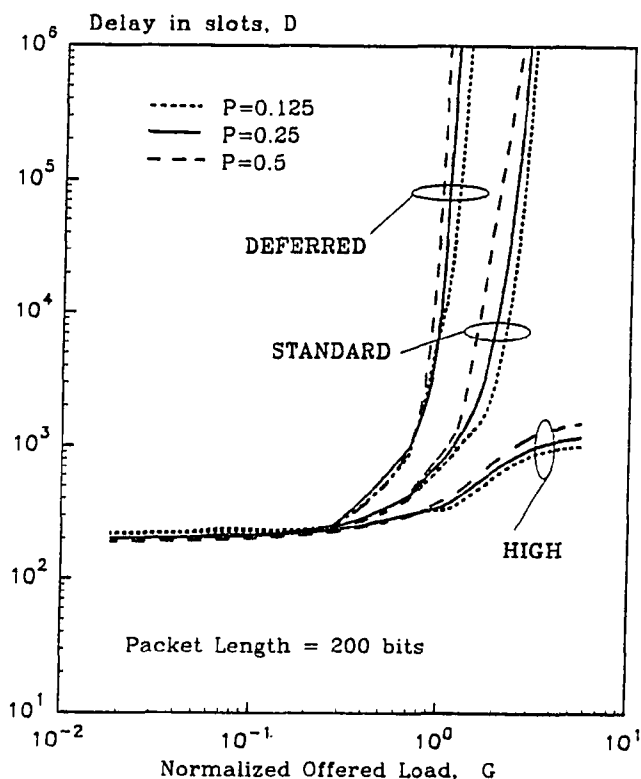

Fig. 3.13 Effect of Persistent Mechanism with respect to Packet Delay versus Traffic Load at Packet Length=200.

additional delay up to 4 USTs according to the queued state of the node, as used in simulation.

Throughout the Figs. 3.8 - 3.11, it was observed as the packet length becomes larger, that the delay increases initially because any priority message requires at least its own transmission time, so a larger packet needs more time. This is plotted in Fig. 3.12 which shows delay as a function of packet size. The delay of all messages and for all priorities also increases with traffic load. As the packet length becomes smaller, and for moderate values of traffic load, in the middle range (0.1 to 0.7), the messages have behaved properly in a reasonable manner, and according to their priority class.

Fig. 3.12 shows delays in slots as a function of packet size for the full load delay (FLD), half load delay (HLD), and zero load delay (ZLD). Here, full load is defined as the value of 1.0 in the offered load, i.e., the offered load is 100% of the channel capacity. Half load is also defined at 0.5 in the offered load, i.e., the traffic load is 50% of channel capacity. Zero load means that the offered load is very light, tending to zero. The H, S, and D inside the parenthesis stands for HIGH, STANDARD, and

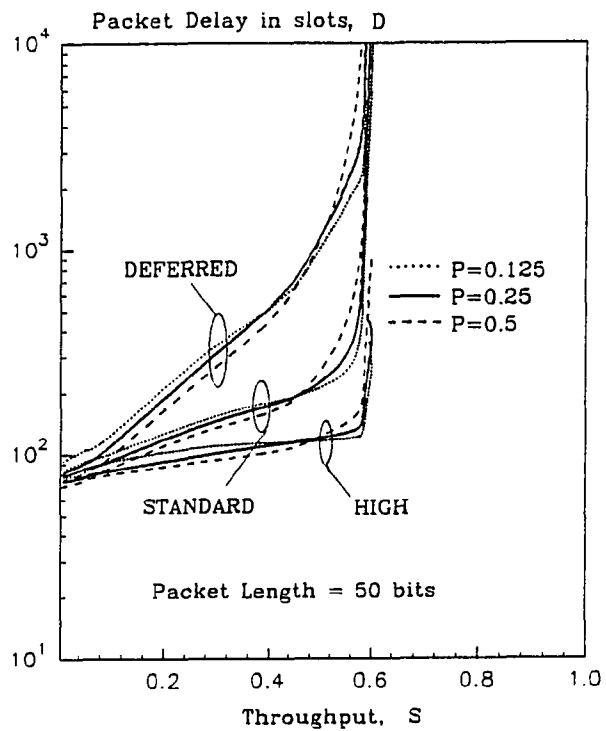

Fig. 3.14 Packet Delay versus Normalized Throughput for Three different  $P$ -persistent values at Packet Length = 50 bits.

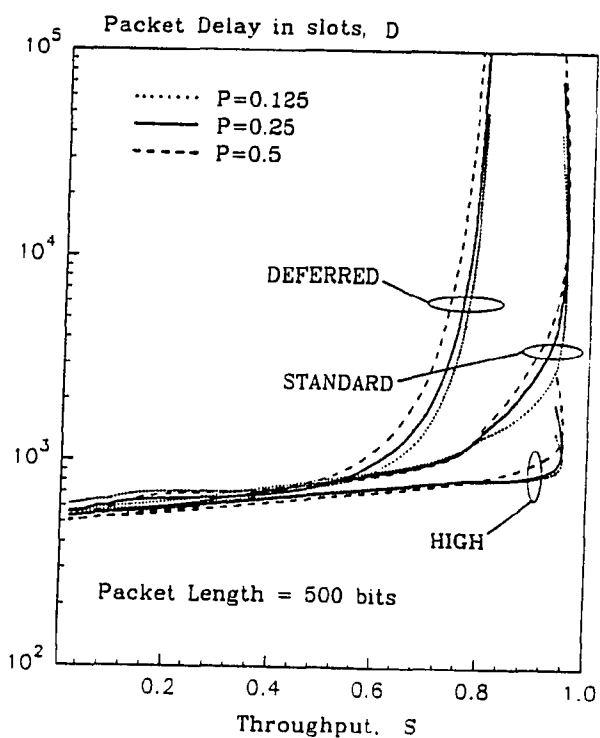

Fig. 3.15 Packet Delay versus Normalized Throughput for Three different  $P$ -persistent values at Packet Length = 500 bits.

DEFERRED priority message. The ZLD rises linearly as the packet size increases and the ZLD curve represents delay for all priority messages. So to speak, all of the message priorities have the same delays approximately under the condition of very low traffic loads because all priorities are able to transmit a packet fairly. For the FLD (High) and FLD (Standard), the difference between the two values becomes larger as the packet size increases. At a half load, i.e. offered load 50% of the channel capacity, the range of packet sizes used all result in plausible distributions in which messages of any priority are able to transmit a packet. However, the messages experience different delays according to priority. For a packet size of 50 bits, the delay of each priority does not show great difference as a function of traffic loads. Whereas, at packet size of 1,000 bits, large differences in delay appear as the load varies. However, the CEBus requires as minimum packet size 96 bits which must be available to provide the source address, destination address, house address, frame check sequence, and some modicum of data.

A study has been conducted on the sensitivity of delay and throughput to the  $P$ -persistent channel access parameter  $\nu_p$ . The results are shown in Figs. 3.13 - 3.15. In Figs. 3.13 - 3.15 packet delay versus offered load as well as throughput is shown for the proposed protocol (PAMA/PR) with packet length  $T=50, 200$ , and 1,000 bits.

The  $P$ -persistent channel access procedure allows ready stations to randomize the start of transmission following the instant at which the channel goes idle while using the priority scheme. Fig. 3.13 shows the packet delay as a function of offered traffic load for the  $P$ -persistent strategy at packet length 50 and 200 bits, respectively. Decreasing  $P$  or  $\nu_p$  in light loads leads to small increases of packet delay  $D$ . However, when the channel load exceeds some threshold, larger  $P$  incurs a higher packet delay.

Also in order to study the sensitivity of packet delay to  $\nu_p$ , the packet delay versus normalized throughput for three different  $P$ -persistent values with parameter  $\nu_p$  is shown in Figs. 3.14 and 3.15. In heavy load, smaller values of  $P$ , i.e.,  $\nu_p$ , achieve

slightly higher maximum channel throughput and lower delay. When the offered load increases further, the smaller value of  $P$  will refrain from decreasing the throughput, while the larger value of  $P$  results in higher delay due to increased collisions. As the value of  $P$  in heavy loads increases, the throughput starts to decrease after the achievable maximum throughput is reached. It is seen that, in general, the channel throughput and delay are fairly insensitive to changes in  $P$  falling in the range 0.2 – 0.7. This behavior is not surprising and in agreement to the known results of  $P$ -persistent P-CSMA-CD scheme on a broadcast bus with two classes of priority [24], [59].

In order to investigate the difference of delay time in the CEBus simulation experiments, two types, i.e., packet and message delay are plotted in Fig. 3.16.

In heavy offered load, the difference between message and packet delay is large. Thus if we consider the queueing delay, it is not desirable to have an offered load more than 2.5. Overall, considering packet and message delays for each priority we may require the offered load to be less than 0.7 when using a packet size of 300 bits.

### 3.4 Summary

In this thesis a new theory for the multi-priority CSMA/CD protocol of the CEBus has been developed. The proposed PAMA/PR (Priority Channel Assigned Multiple Access with Priority Reservation) protocol employs demand priority channel access, minimum wait time, persistent start of transmission to redress collisions, and contention resolution based on priority. An exact theoretical formulation has been written for it. It has turned out to be mathematically complex. The resultant complexity has stemmed mostly from the fact packet departure times are dependent on a priority basis, i.e., the lower priority level is dependent on the higher priority and node state. In addition, the use of the attribute of queueing state, i.e., whether a station

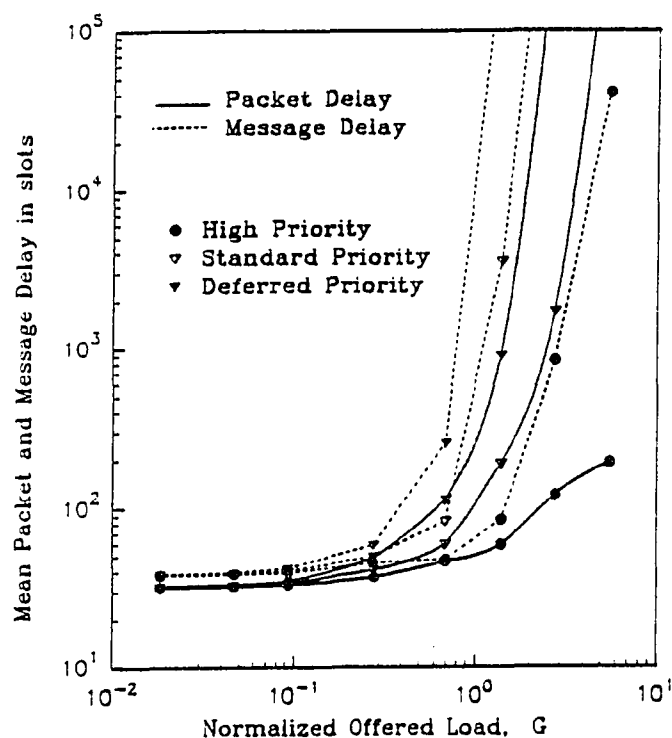

Fig. 3.16 Message and Packet Delay Comparison versus Normalized Traffic Load with Packet Length=300 bits

is in a unqueued or queued state, and collision resolution during the preamble field, make the analysis more difficult. However, the employment of the queueing state of a station for each priority as well as contention resolution during the preamble bits can be accounted for easily in the simulation experiments.

The simulation results have shown a somewhat more efficient performance over the mathematical model of the CEBus protocol at heavy loads. There are several aspects of the CEBus protocol which have not been fully and identically treated in the mathematical formulation. In particular the mathematical formulation of the queueing state mechanism along with contention resolution using an 8 bits preamble within each priority has been found difficult to carry out.

Through the analysis, it has been observed that the priority scheme has behaved well in handling messages for each priority. In light load the messages of all the priorities have remained low and bounded and have shown similar, almost identical, delay distributions. Even, in heavy load, the HIGH priority message delay continues to stay low and bounded while DEFERRED delay rises drastically and STANDARD



shows only mild delay increases. At or slightly more than offered load of 0.5, i.e., 50% of channel capacity, for a wide range of packet sizes we find reasonable distributions in which messages for any of the 3 priorities may be transmitted even though each priority experiences quite different delay times.

Another informative experiment was to observe delay performance by adjusting  $P$  in order to vary the length of the contention period and accordingly the probability of a successful transmission. In heavy traffic load, smaller values of  $P$ , i.e.,  $\nu_p$ , achieve slightly higher maximum values for channel throughput and lower delay. In further offered load, lower value of  $P$  will refrain from decrease of the throughput, while higher value of  $P$  results in higher delay due to collisions. As the value of  $P$  in heavy loads increases, the throughput starts to decrease after achievable maximum throughput is reached. In light load, the  $P$ -persistent procedure does not effect the delay as much as the delay in heavy load. It is seen that in general the channel throughput and delay are fairly insensitive to changes in  $P$  within middle range of 0.2 – 0.7. When, therefore, very heavy loads are expected, the small value of  $P$ -persistent procedure may be required.

The change in performance as a function of load could be investigated in asymmetric traffic configurations. Also, the effect of the number of stations with respect to delay-throughput characteristics could be studied with both the analytical and the simulation models. In the network several messages of the same priority class may be simultaneously present and should be able to contend for the channel with equal right (fairness within each priority). This contention problem was resolved by the *persistent* mechanism in the analysis, and by random start delay of 4 slots and contention resolution in the preamble field in the simulation.

Some difficult aspects of the CEBus protocol encountered in the theoretical formulation of the model have been handled effectively. Of course, the simulation model has employed random start delay for each priority and the contention resolution in the

8 bit preamble field. The  $P$ -persistent scheme has been used in the mathematical formulation. The high complexity in the exact analysis may be reduced by approximate expressions.

In the analysis the number of packets accumulated at the end of a transmission period is simply the number of arrivals during that transmission period. In other words, the packets which were already buffered at the beginning of the transmission period are discarded. Instead, in the simulation experiments all the accumulated packets may be kept in the buffer until they are successfully transmitted. Thus, the number of packets accumulated during a transmission period would depend on the packets already buffered at the beginning of the transmission period.

In order to investigate the variation in delay time, packet delay and message delay are shown in Fig. 3.16 CEBus simulation experiments. In heavy offered load, the difference between message and packet delay is large. Thus, if the queueing delay is included, it is not desirable to engage an offered load of value more than 2.5. Overall considering packet and message delays for each priority we may require offered load less than 0.7 for a packet size of 300 bits.

In this chapter, the results of numerical analyses based on a mathematical formulation of the CEBus protocol were shown to be in close agreement to the results of the simulation experiments. The performance characteristics showed only slight difference of the two mostly at heavy traffic due to several departures in the two models, as explained earlier. In addition, the theoretical analysis may be enhanced by incorporating an acknowledgement service.

# CHAPTER 4

## PERFORMANCE WITH THREE PRIORITY ROUTER

### 4.1 General

The Consumer Electronics Bus (CEBus) is intended to provide economically to the home a shared local communication network which carries relatively short digital messages. An implementation of the CEBus on some physical medium is able to co-exist with every other implementation of it. Every device should be capable to communicate with all other CEBus devices on any of the supported physical media, which are the Power Line, Twisted Pair, Coaxial Cable, Infrared, Radio Frequency, and Fiber Optic.

The protocol layering of the CEBus corresponds with the Open System Interconnection (OSI) architectural model of the International Organization for Standardization (ISO). By this required specification, the CEBus can be extended and interconnected to various media through a router, a bridge, or a gateway. The objective of this chapter is to provide simulation results for the throughput and delay behavior between the Power Line (PL) and the Twisted Pair (TP) physical media interconnected by a router which can handle three priority messages.

The router architecture of the CEBus is layered in the same manner as a node. However, it features two Medium Access Control (MAC) Sublayers and Logical Link (Control) Sublayers using the same Network Layer. The use of a priority algorithm

with three priorities. enables a higher priority message to preempt a lower one while the latter is waiting for channel access.

## 4.2 Brief Description of the CEBus Protocol

The CEBus imposes restrictions on the use of a priority request attached to a packet. The effect of a *priority* level is to delay the transmission of a message for an additional period of time as follows:

a). HIGH Priority

A High priority message will not cause any additional delay to the transmission of that message. These applications include light switches, telephone services, security and/or emergency controls and alarms, Audio/Video equipment control, and others.

b). STANDARD Priority

A standard priority will impose 4 unit symbol times (USTs) of additional delay to a message transmission. These applications include Resource Allocation, sensor activated HVAC devices, and closed loop control. Many examples of this level may be found in kitchen devices and laundry facilities.

c). DEFERRED Priority

A Deferred priority level will require an additional 8 USTs. The lower priority nodes will always listen for the higher priority nodes and defer to them. These activities include background traffic, automatic controls which do not require immediate response, and data logging.

A transmitting node is considered to be in either a “Queued” or an “Unqueued” state. This *round-robin queueing* scheme ensures that contending nodes each have an equal opportunity for channel access. The effect of the queueing process is to remove

the successful nodes from contention with those which have not yet been able to get a message through.

A node which has already successfully completed a transmission will be placed in the Queued state. This state introduces an additional delay of 4 USTs into a node's channel access. The *Unqueued State*, which requires no additional delay, is assigned delaya node which has not yet successfully transmitted a packet.

*Randomization* is employed to reduce the probability of contention whenever more than one node may be in the same priority level and queueing state. A randomly assessed delay of either 0, 1, 2, or 3 USTs is added to each transmitting node's channel access delay. The delay is set to the sum of the least significant two bits of the current Preamble value and the least significant two bits of the local address.

*Contention detection* is accomplished with the use of SUPERIOR and INFERIOR media states. It is essential to the process of contention detection that a SUPERIOR state dominate the medium over an INFERIOR one. The Preamble, positioned at the beginning of the frame, serves to provide a contending signal pattern and to shield the information from being lost during contention.

*Contention resolution* is employed in the CEBus. The Physical Layer of any node which detects a SUPERIOR state on the medium, while attempting to transmit an INFERIOR state, immediately ceases its transmission without collision. In CEBus terminology, a collision is defined as overlapping transmissions after the Preamble.

The Physical Layer then sends a *PH\_CC\_DATA.confirm* service primitive to the Data Link Layer (DLL) to abort its transmission, begin receiving, and defer until the end of the frame which retained the channel [4]. Once the EOP symbol is received, the deferring nodes begin counting their channel access delays. Signal rates for the Power Line (PL) and Twisted Pair (TP) are both 10,000 ONE b/s. Here ONE represents a unit symbol time (UST) which is the width of the smallest symbol, a logical 1. A UST is 100  $\mu$ s, and logical 0 stands for 2 USTs.

## 4.3 Simulation Experiments

### 4.3.1 Router

A router is a device which bridges two implemented media in a CEBus network. Routers may be designed which bridge more than two media. As described in the OSI reference model, a CEBus router connects network segments which may communicate using the same Network Layer protocol but different Data Link Layers. Routers forward packets from one medium to another, if doing so moves the packet closer to its destination. A router must receive packets from one medium, buffer the packets, and decide whether or not to forward each packet onto the next medium, based on a routing algorithm and a list of other criteria [4].

The architecture of the CEBus router is layered in the same manner as the CEBus nodes. However, it has two Medium Access Control (MAC) Sublayers and Logical Link Control(LLC) Sublayers; each of them is attached to the PL and TP networks, respectively. In the CEBus network, each router must communicate with the other routers to maintain the network topology in a tree structure [6]. However, the simulation model compromises a router which connects two media, the PL and TP. The simulation utilizes an unacknowledged connectionless service which provides an exchange of data between peer Network Layers without use of an acknowledgment mechanism to verify the success of the transmission.

Packet priority is used by a transmitting MAC sublayer to set self-imposed channel access delay. Within the Network Layer of a router, the priority enables a priority queueing scheme to take place in the router forwarding buffer. In order to handle three priority messages, the router is assumed to have three infinite buffers to store and forward the packet for each priority. Priority also enables a higher priority request to preempt a lower priority request while the latter is waiting for channel

access. However, once the lower priority message starts to deliver its data, the higher priority request is no longer able to preempt it.

### 4.3.2 Network Model and Traffic Patterns

The data rate of the CEBus for the home environmental network is quite low. The Power Line (PL) and Twisted Pair (TP) physical media each employ 10 Kb/s, respectively. In the simulation experiments, this data rate of 10 Kb/s has been utilized for both media. Generally speaking, local area networks using wire pairs may operate up to a couple of Mb/s range. The standard operating rate for coaxial cable is in the neighborhood of 10 Mb/s. For optical fiber, it is several hundred Mb/s and rising. If lasers and single-mode fibers are deployed, the range of bandwidth is far higher, in the Gb/s. By reason of this low channel capacity in the home environment, large delay and high normalized channel throughput may be predicted in comparison to other networks with high bandwidth. However, the channel throughput turns out to be substantial. This high throughput is due to relatively larger packet sizes with respect to the network capacity. For the simulation studies, the LANSF protocol modeling facility [83] has been utilized.

The flowcharts of the transmitter and receiver process for the CEBus are plotted in Figs. 9.1 and 9.2 along with functional descriptions of the layers of a node. In the CEBus functions, the data service primitives for unacknowledged connectionless service are composed *XX\_DATA.request*, *XX\_DATA.indication*, and *XX\_DATA.confirm*. Here “XX” represents one of the N, LL, MA, and PH. For example, *N\_DATA.request* is the data transmission request primitive from the Network Layer (NL) to the LLC Sublayer in a transmitting node when the NL entity wishes to send an LSDU (LLC Service Data Unit) to one or more remote NL entities using unacknowledged connectionless service.

An example of *LL\_DATA.confirm* is the data transmission confirmation primitive

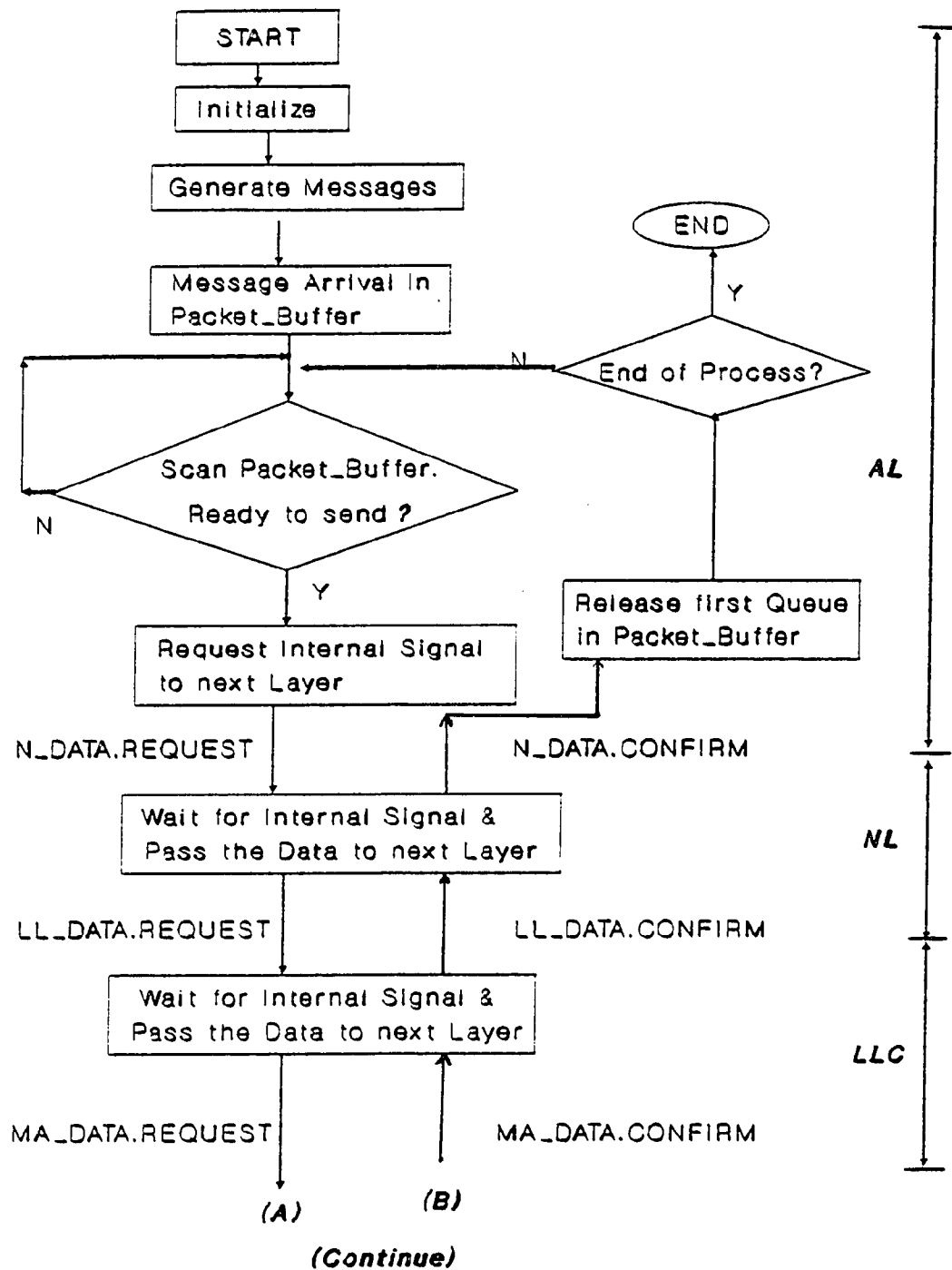

Fig. 4.1 Flowchart of the Node Transmitter.



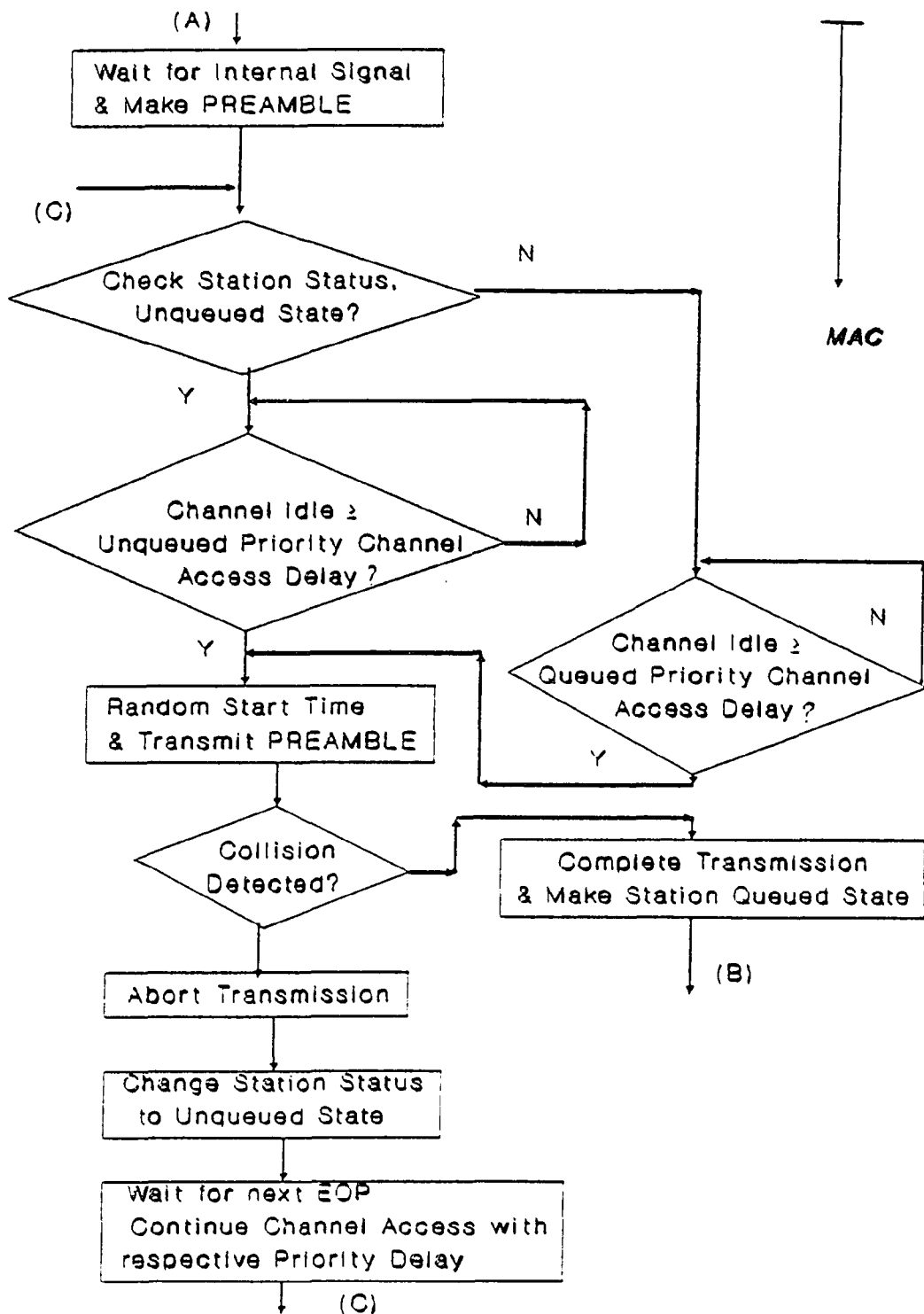

Fig. 4.1 (Cont.) Flowchart of the Node Transmitter.

for unacknowledged connectionless service. This primitive is generated by the local LLC entity of the transmitting node and is passed to the NL entity. The queued message in the buffer cannot be released unless the Application Layer (AL) gets the service primitive of *N\_DATA.confirm*.

As an example of the *indication* service, the *LL\_DATA.indication* service primitive is sent from the LLC Sublayer to the NL in a receiving node signifies data reception whenever the LLC entity has received a LSDU which is destined for the NL.

The assumptions used to develop the model are as follows:

- Independent Poisson arrival process at each station with rate  $\lambda$  packets/sec;
- The packet lengths are exponentially distributed with mean  $L$  bits;
- The end-to-end propagation delay around the CEBus network is ignored <sup>1</sup> ;
- The bit rate on the channel is  $c$  b/s;
- There are  $M$  nodes on the network.

The total number of nodes,  $M$ , utilized in the simulation is 18 plus 1 for the router. there are 9 nodes on each medium; 3 nodes are assigned to one of the three priority classes on each medium. All the generated messages are symmetric for each priority class, thus each of the 18 nodes employs the same rates to get access to the medium. The offered load is measured in terms of the three groups as following relations:

$$\begin{aligned}
 G_{PL} &= \frac{\lambda_{PL \rightarrow PL} L_p + \lambda_{PL \rightarrow TP} L_p + \lambda_{PL \leftarrow TP} L_p}{c} \\
 G_{TP} &= \frac{\lambda_{TP \rightarrow TP} L_p + \lambda_{TP \rightarrow PL} L_p + \lambda_{TP \leftarrow PL} L_p}{c} \\
 G_{PL} &= G_{TP}
 \end{aligned} \tag{4.1}$$

---

<sup>1</sup>In the home environments, a parameter  $a$  defined by (propagation/ packet transmission time) is ignorable since the propagation delay is much smaller than packet transmission time.

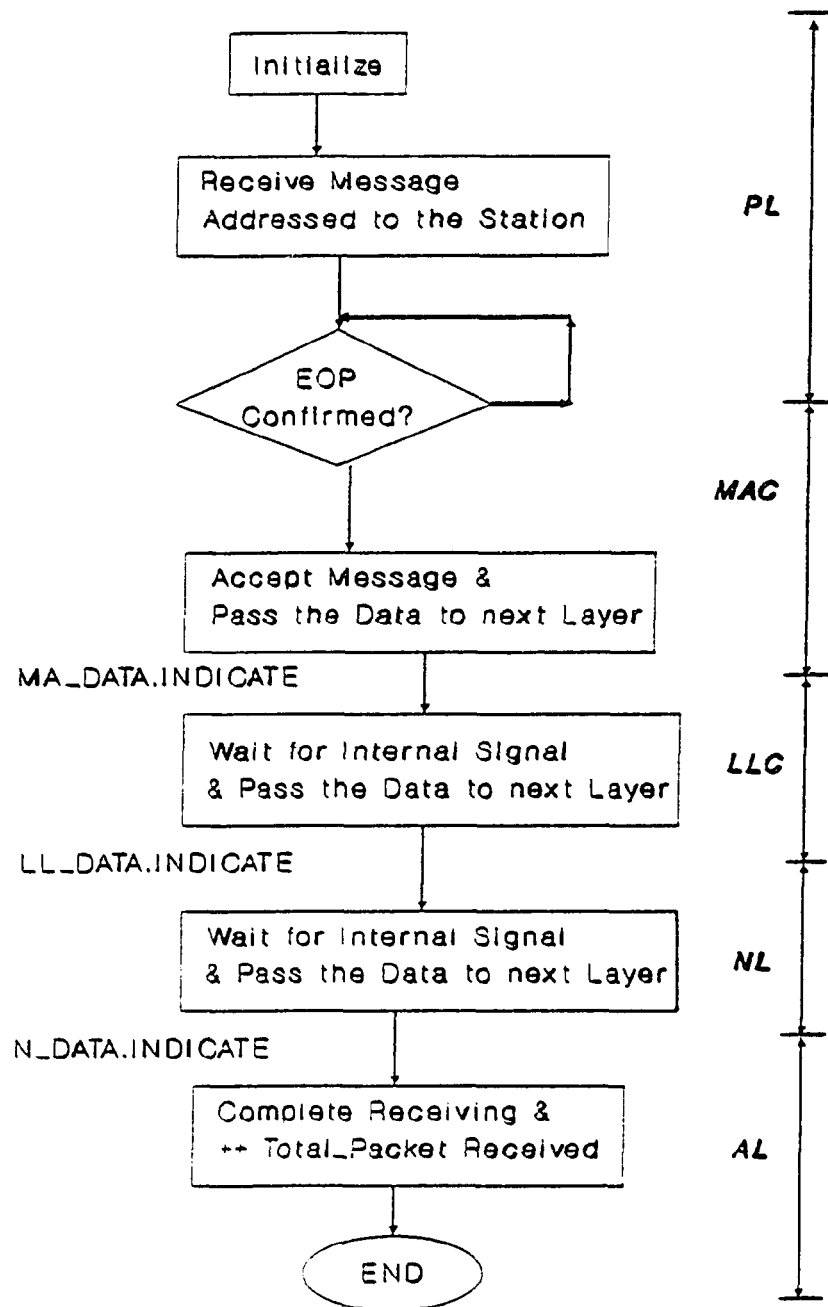

Fig. 4.2 Flowchart of the Node Receiver.

Here  $c$  is the channel capacity or data rate in bit/sec,  $L_p = L_h = L_s = L_d$  is same packet length in bits,  $\lambda_{PL \rightarrow PL}$  denotes the arrival rate from the PL to itself,  $\lambda_{PL \rightarrow TP}$  denotes the arrival rate from the PL to the TP, and  $\lambda_{PL \leftarrow TP}$  is the traffic rate in the reverse direction,  $\lambda_{TP \rightarrow TP}$  denotes the arrival rate from the TP to itself. These groups have the same arrival rates, i.e.,  $\lambda_{PL \rightarrow PL} = \lambda_{PL \rightarrow TP} = \lambda_{PL \leftarrow TP} = \lambda_{X \rightarrow Y}$ . Each direction group is composed of the three priority classes so that  $\lambda_{X \rightarrow Y} = \lambda_h + \lambda_s + \lambda_d$ , where  $\lambda_h = \lambda_s = \lambda_d = \lambda_p$ . Here the subscript  $p$  denotes one of the three priorities: h=HIGH, s=STANDARD, and d=DEFERRED. In this simulation study the packet length employed is 300 bits.

#### • Measures of System Performance

There are basically four performance aspects of the system that we consider in this work.

- (a). **Message Delay** which was measured as the time elapsing from the moment the message was queued at the sending node to the moment the entire message is successfully received at the destination (including the message queuing time).
- (b). **Packet Delay** was measured as the time elapsing from the moment the packet became ready to be transmitted to the moment the entire packet is successfully received at its destination.
- (c). **Message Throughput** was calculated as the ratio of the total number of bits received at the destination address to the number of bits generated at the source .
- (d). **Channel Throughput** was measured as the ratio of the total number of information bits successfully transmitted through the link to the simulation time. This sometimes is also referred to as *effective throughput* of a link, in that it includes not only the bits that were received on the link, but also the bits that were successfully relayed to some other link, e.g., to the router.

In this simulation message and channel throughput, and mean message and

packet delay have been investigated in terms of normalized offered load for the intra- and inter-network traffic through a router. The router is assumed capable of handling all three priority classes. In order to evaluate the performance of the CEBus, the Power Line (PL) and the Twisted Pair (TP) media are interconnected via a router.

Fig. 4.3 explains message and channel throughput versus normalized offered load for intra- and inter-network traffic with packet length 300 bits. The channel throughput increases continually as the offered load increases up to 1.0 approximately, and then it starts to decline slowly after a while. Message throughputs of the inter-network traffic for all priority classes are worse than those of intra-network traffic communicating each other on the PL bus. For example, the message throughput of the DEFERRED priority message for the intra-network traffic starts to decrease sharply at 85% of the channel capacity, while that for the inter-network traffic starts to decline at 55% of the capacity.

Fig. 4.4 is the similar to Fig. 4.3, but indicates the intra-network traffic for the TP network and inter-network traffic from the TP to the PL medium. The maximum achievable throughput is 0.88 in the case of packet length equal to 300 bits. According to the priority level, the message throughput of the lower priority message starts to decrease in smaller traffic load than the higher priority message as shown in figure. Even for the HIGH priority message, the message throughput starts to decrease at offered load values around 4.0.

In Fig. 4.5, message and packet delays in *ms* are plotted in terms of normalized offered load with packet length 300 bits for the intra-network traffic on the PL medium. In heavy traffic load, HIGH priority message delay which includes the queueing time in the buffer, becomes excessively large, while the packet delay, which accounts for just channel access plus transmitting time, remains small and bounded. The curves of the message delay start to exceed the curves of the packet delay at larger values than about 0.5 to 0.6 in offered load.

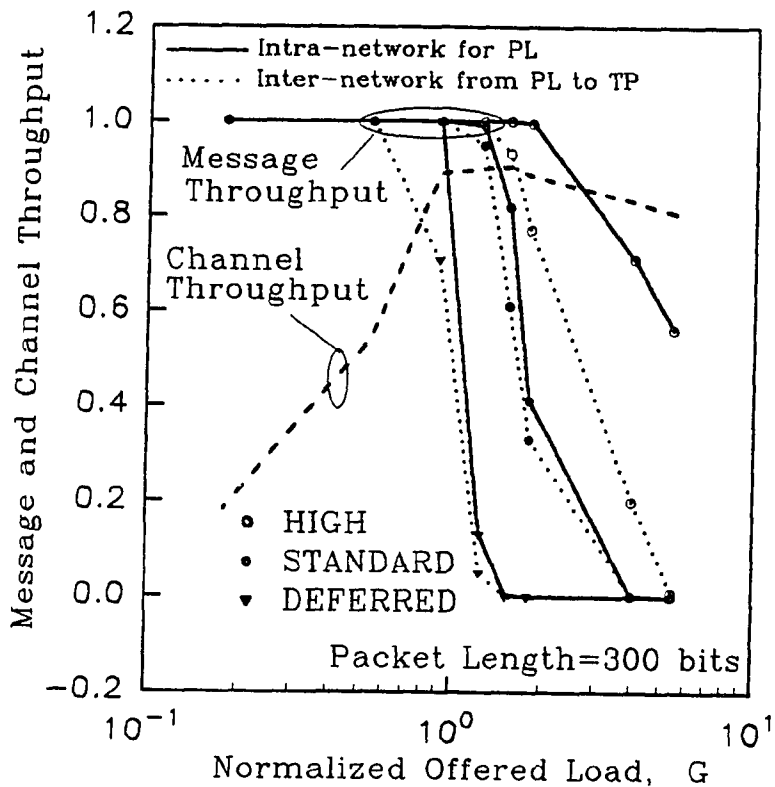

Fig. 4.3 Message and Channel Throughput versus Offered Load for Intra-network Traffic of PL and Inter-network Traffic from PL to TP.

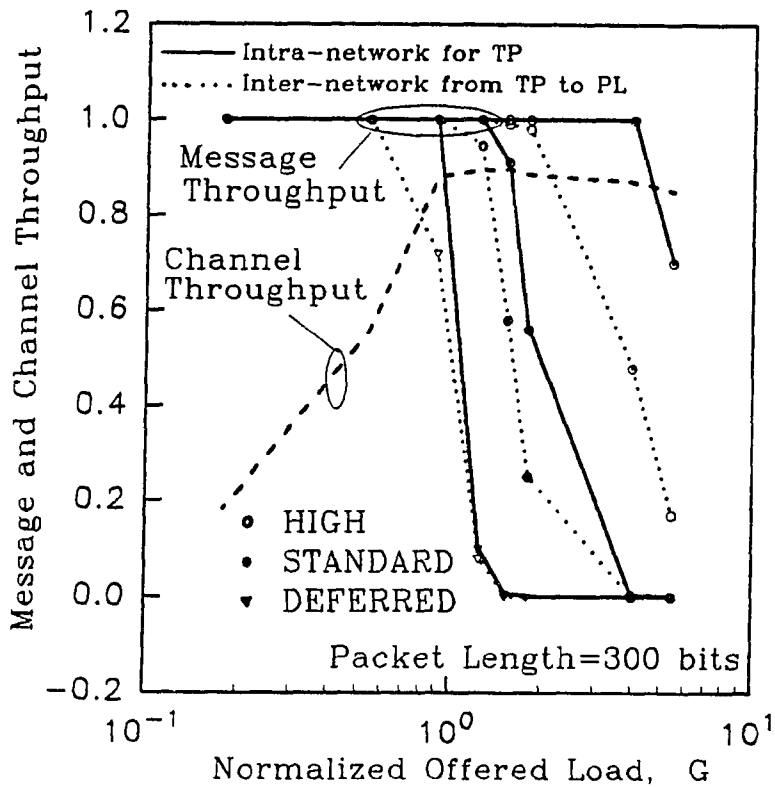

Fig. 4.4 Message and Channel Throughput versus Offered Load for Intra-network Traffic of the TP and Inter-network Traffic from TP to PL.

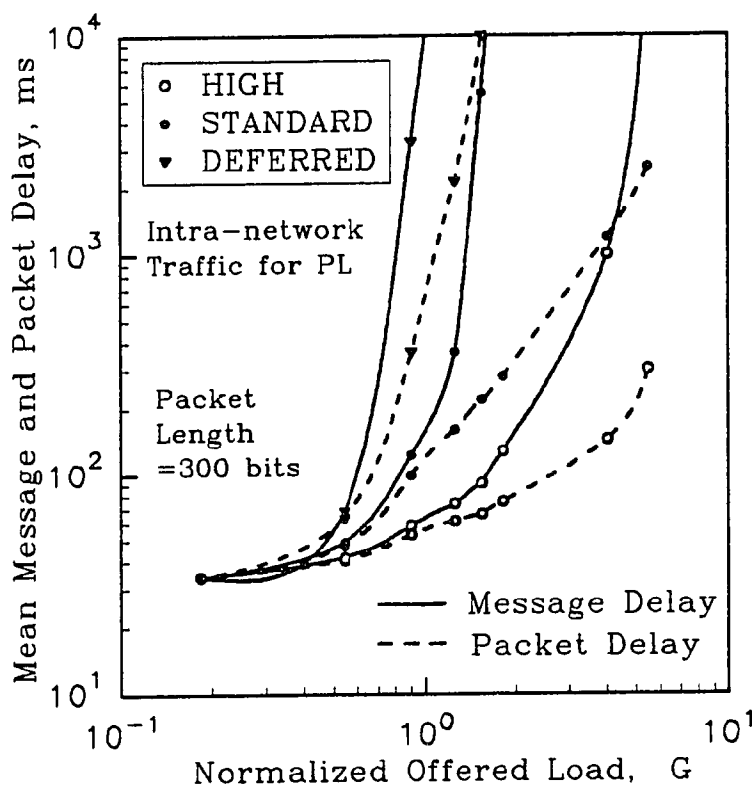

Fig. 4.5 Message and Packet Delay versus Offered Load for Intra-network Traffic on the PL with Packet Length 300 bits.

Fig. 4.6 shows the message and packet delay for inter-network traffic from the PL to the TP with packet length equal to 300 bits. For traffic through the router, message delay and packet delay do not show any big difference, mostly because after a message succeeds in reaching the router, it usually fails to access the channel on the other side immediately so it has to wait in the router buffer and then try access the channel again. For inter-network traffic between the PL and the TP, the delays for each priority start to increase at 50% to 60% of the channel capacity. The delay performance for inter-network traffic from the TP to the PL as well as for intra-network traffic on the TP as a function of throughput is shown in Fig. 4.6. On the whole, inter-network traffic shows higher delay values initially compared with those of intra-network traffic. Thus in light traffic load, the packet delay for inter-network traffic amounts to 100 ms initially, while the initial delay for intra-network traffic is about 30 to 40 ms. The packet delay of both groups starts to increase with different rates at the throughput value of 0.6. Furthermore, it should be noted that the DEFERRED priority message for inter-network traffic is no longer able to

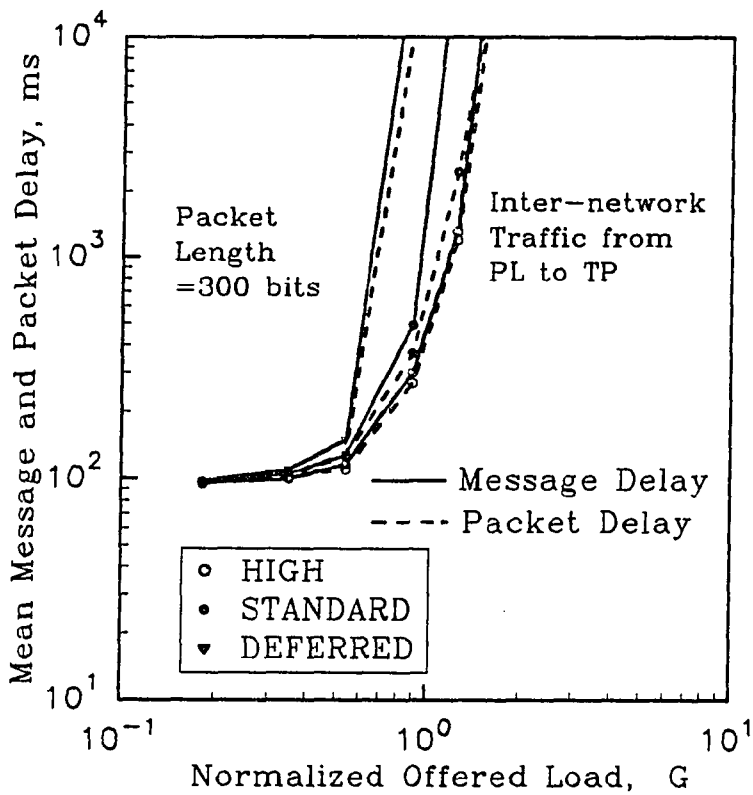

Fig. 4.6 Message and Packet Delay versus Offered Load for Inter-network Traffic from PL to TP with Packet Length 300 bits.

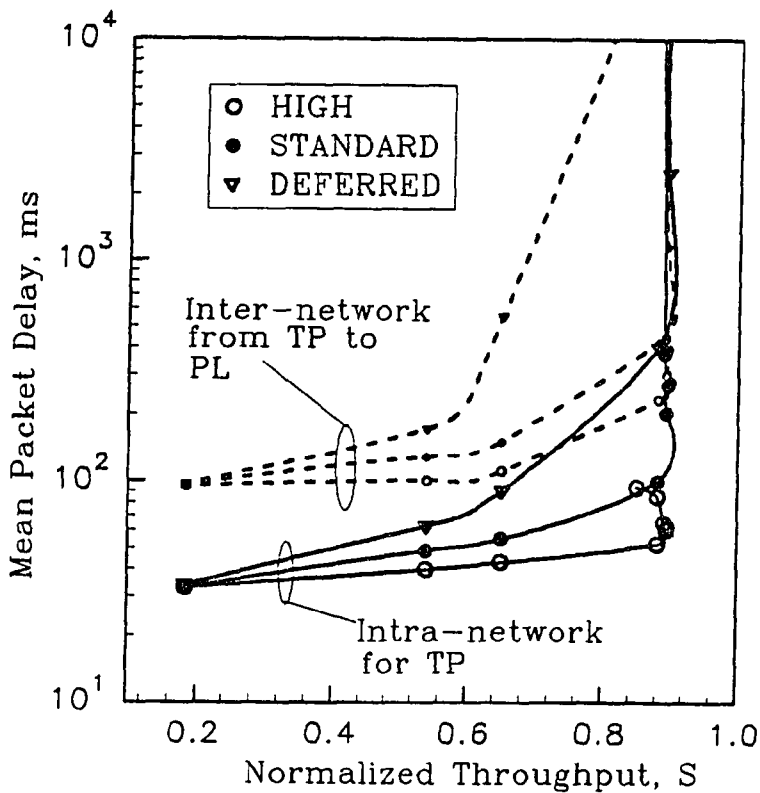

Fig. 4.7 Mean Packet Delay versus Offered Load for Intra-network Traffic on TP and for Inter-network Traffic from TP to PL with Packet Length 300 bits.



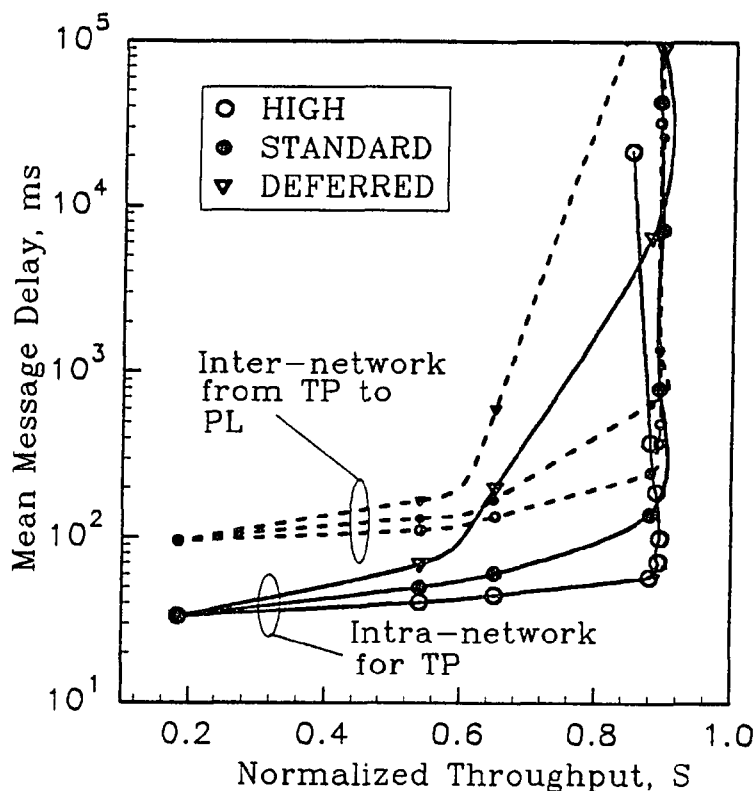

Fig. 4.8 Mean Message Delay versus Offered Load for Intra-network Traffic of the TP and Inter-network Traffic from TP to PL.

transmit a packet as soon as normalized throughput reaches 0.8.

Fig. 4.7 displays the mean packet delay in *ms* versus normalized throughput for the intra-network traffic on the TP and for the inter-network traffic from the TP to the PL. After the normalized throughput reaches 0.65, the curves for both groups start to show big delays according to priority level. Near the maximum achievable throughput (0.9 approximately) as the load increases further, the HIGH priority packet delay for the intra-network traffic stays bounded while the delay for inter-network traffic increases to very high values.

In contrast to Fig. 4.7, Fig. 4.8 shows mean message delay in *ms* in terms of the normalized throughput. In light load, message and packet delays show similar distribution curves, however, as the traffic load rises further, i.e., as the throughput nears the maximum point, the delay for all of the messages increase dramatically.

## 4.4 Summary

A performance evaluation has been carried out by simulation experiments when router traffic is present between the PL and TP media. The message and channel throughput, and message and packet delay have been studied for a range of offered traffic loads; channel throughput and offered load are normalized to channel capacity. The router, which can handle three priority levels, has behaved well, according to message priority. The inter-network traffic has showed larger delay than intra-network traffic. Thus in light loads the inter-network message delay was measured at about 100 *ms* while the intra-network traffic for the same network showed much smaller delay, approximately 30 *ms* to 40 *ms*. Thanks to the lower priority message's deference to higher priority ones, the HIGH priority message for the intra-network traffic has shown satisfactory delay characteristics all the way up to the 3.0 value of offered load, keeping the delay time to less than 500 *ms*, whereas the HIGH priority message for inter-network traffic exhibits acceptable performance up to approximately 0.95 of offered load, keeping the delay under 500 *ms*. At offered load values larger than 55% of the channel capacity, the DEFERRED priority message for the inter-network traffic can no longer transmit a packet with bounded delay, and cuts out for intra-network traffic at offered loads approximately 70% to 80% of the channel capacity. Using simulation experiments, the message throughput for each priority intra- and inter-network traffic was investigated. With the packet length fixed at 300 bits, the channel throughput first rose to 0.9 approximately, as the offered load increased, and then started to decline due to rising channel access contention. In conclusion, the CEBus protocol with a 3-priority router is observed to be very suitable for light traffic not exceeding 60% to 70% of channel capacity. It can be concluded that the CEBus can provide satisfactory performance for the HIGH priority as well as offering reasonable capacity to share the lower priorities.

# CHAPTER 5

## CEBUS TO ISDN GATEWAY DESIGN

### 5.1 Back Ground

The CEBus supports communication for appliances and devices in the home. A Local Area Network (LAN) could connect Routers to each other or to offices. In the networking domain the integrated services digital network (ISDN) is being developed so that true integration of voice and data may be provided using a common standard interface and common cabling.

In the early 1980s the detailed recommendations for an integrated services digital network (ISDN) was developed, with the goal of eventually producing a network capable of using the same switching and communications equipment for a whole range of traffic, in particular voice, data, text, and some video.

The typical commercial LANs provide at least 1 Mbit/s data rates. They are also subclassified into broadband or high speed baseband. The interfaces and their converter protocols have been developed in order to support a diverse variety of LANs. The CEBus, a home environment LAN employs very low data rate, i.e., 10 K bits/sec, exactly 10K ONE b/s. In this context, ONE stands symbolically as a time unit and represents the time needed to transmit the shortest symbol, have known as a UST (Unit Symbol Time).

In the late 1980s, *basic rate* systems already became available in several countries,

and so-called *primary rate* is fast being applied at 2 M bits/sec. The most important part, as far as the user is concerned, is the user interface and access scheme to the ISDN. In support of this CCITT has developed the I-series protocols which define the user interface to the ISDN.

It will be of considerable utility to connect the CEBus, a home to the ISDN lines. In the ISDN there are two types of channel, B channels for voice and data and D channels for signalling and system use (control). D channel allows network systems functions so-called *out-band* signalling such as call setup and error indications to be passed using a separate channel from the data/voice channels. The D channel can also be used to convey user data if required. By the way of contrast, consider the present (analogue) telephone system, where call setup and voice transmission use the same channel, at different times.

In connecting the CEBus to ISDN, *Basic rate* interfaces may be used which are a combination of B and D channels, i.e.,  $2B + D$ . They provide two data/voice channels each capable of 64 Kbits/sec operation, plus a signalling channel of 16K bits/sec.

## 5.2 The ISDN

### 5.2.1 ISDN Interfaces

Quite often it is desirable to connect two LANs or a LAN and a WAN to each other. This is the case with the CEBus, a LAN servicing an individual home, and the ISDN, a network serving a large multitude of homes and business.

*Repeaters* may be used to connect two common LANs, which in this case, are of the regenerative type. For example in order to provide a 500-m extension segment in CSMA/CD, a repeater is required at the segment end bridging it to the original section which can also be up to 500 m long. Up to five segments may be spliced together for a total extension of 2.5 km for an Ethernet-CSMA/CD LAN.

The first two of OSI layers are required for the 802 series LANs and FDDI. Thus a *bridge* has to carry out a conversion of OSI layers 1 and 2 so that the protocols will interface at each peer level and the two LANs will be capable of interworking. The higher levels are indeed made compatible peer to peer.

Since the ISDN has been intended to access the existing public telephone network, including circuit and packet switched networks, along with the telex network, and other public or private facilities dedicated to particular types of telecommunication services. Home terminals such as a PC, a master telephone set, and a TV may be connected with the ISDN through a properly designed interface. Fig. 5.1 illustrates user-to-network interface types, which include basic access, primary, and broadband access interfaces.

A *gateway* provides an interface between a LAN and an external data network through a common Application Layer. The goal of ISDN is to provide an integrated facility to incorporate each of the services listed on a common 64-Kbps channel and/or a combination of 64-and 16-Kbps channels [86], [98]. ISDN has been developed for integration of all services; these include digital voice, high-speed data both circuit and packet switched, telex/teletex, telemetry, facsimile, and slow-scan video.

The CEBus may have an interface to incorporate ISDN services and bandwidth. In ISDN, in-band signaling and framing have downgraded the basic 64 Kbps channel to lower speeds. As a result integrating other services, such as computer data, have required a drop back to 56 Kbps or less for the North America PCM. Typical of such a reduction is ATT's DDS (Digital Data System), which can offer only 56 Kbps, not the more desirable 64 Kbps [88]. Whereas 4 KHz was the basic building block of analog telephony, 64 Kbps is the basic building block of ISDN.

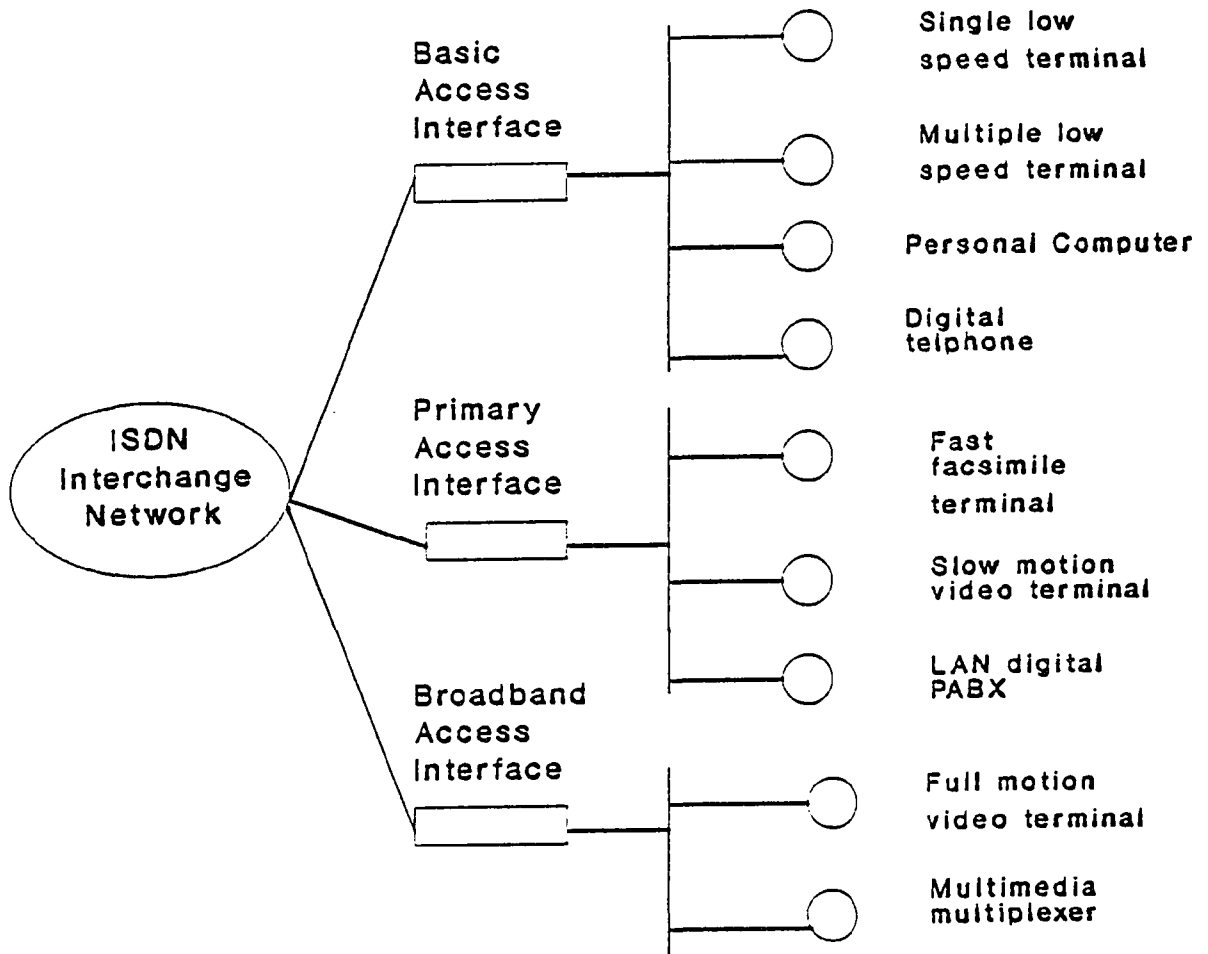

Fig. 5.1 User-to-Network Interface Types.

## 5.2.2 ISDN User Channels

In order to build an interface for the CEBus to communicate with ISDN and to bring in the ISDN services to the home, it is useful to understand the ISDN user channels. The following defines the standard transmission structures for user access links [87], [87]:

- A-channel: 4 KHz analog VF channel.
- B-channel: 64 Kbps.
- C-channel: 8 or 16 Kbps.
- D-channel: 16 Kbps.
- E-channel: 64 Kbps variant of D-channel.
- H-channel:

H0 - 384 Kbps ( $6 \times B$ ).

H11 - 1536 Kbps for 1544 Kbps primary rate.

H12 - 1920 Kbps for 2048 Kbps primary rate.

This H-channel is used for a variety of user information streams, but not for signaling.

The B-channel operates at a synchronous data rate of 64 Kb/s in full duplex mode. Its primary purpose is to carry information between a specific pair of end-users across the S, T, or U reference points of the UNI (User-to-Network Interfaces) [85]. The B-channel which is the basic user channel serves any one of the following traffic types:

- PCM-based digital voice channel (Encoded at 64 Kb/s, according to CCITT Rec. G.711).

- Computer digital data, either circuit or packet switched.
- A mix of multiplexed lower data rate traffic (0.6, 1.2, 2.4, 4.8, 9.6, 48, and 64 Kb/s), digital low data rate voice, and lower data rate computer data (CCITT Rec. X.1).

The D-channel operates at synchronous data rates of either 16 Kb/s or 64 Kb/s in full duplex mode. The primary purpose is to carry the signaling information for the control of circuit switched connections involving one or more B-channels between the user and the network. The services the D-channel structure provides are:

- User signaling channel.
- Lower-speed data connectivity to the network.
- Telemetry signals, priority access for call control signals.

The A-channel structure serves as a transitional expedient to provide nominal 4 KHz analog connectivity to the network.

The C-channel may be incorporated to the A-channel to form hybrid access arrangement.

The E-channel is a 64 Kbps variant of the D channel, signaling for circuit switching. It is only used with multiple access configurations.

The H-channel which does not carry signaling information provides a service for higher user data rates, such as slow-scanning video for teleconferencing, fast facsimile, and packet switched data bit streams. H-channels are designed to carry the types of user information requiring data rates in excess of 64 Kb/s and up to several 100 Mb/s, as multiple of the B-channel or the H0-channel (384 Kb/s).



### 5.2.3 Basic and Primary Interfaces

In order to design an interface for the CEBus – ISDN connection, it is desirable to investigate the currently existing ISDN user interface. The basic interface is made up of two B-channels and a D-channel, i.e., 2B+D. At this interface the D-channel is 16 Kbps. CCITT Rec. I.412 states that the basic access may also be B+D or D.

The primary rate B-channel interface are composed of  $n$  B-channels and one D-channel, where the D-channel in this case is 64 Kbps, as follows:

- 1.544 Mbps = 23B + D.

Generally, ISDN channel =  $nH0 + mB + D$

where the integers  $n$  and  $m$  range over the values

$$0 \leq n \leq 3, 0 \leq m \leq 23, 6n + m \leq 23$$

or in the form

$$nH0 + mB \text{ where } 0 \leq n \leq 4, 0 \leq m \leq 24, 6n + m \leq 24.$$

- 2.048 Mbps = 30B + D.

Generally,  $nH0 + mB + D$

where  $0 \leq n \leq 5, 0 \leq m \leq 30, 6n + m \leq 30$ .

From a transmission point of view, ISDN is designed to offer the worldwide availability of end-to end connections over digital circuits at bit rates and qualities far in excess of those generally obtainable from the existing analog voice network or even from networks with a significant infrastructure of digital circuits such as T1 carriers. Perhaps the most interesting applications of the CEBus toward ISDN relate to the traditional voice communication services, data information for remote home control, and teleshopping such as home shopping, home banking, and home reservation. Among these are calling party identification, multilocation ringing, call waiting, call forwarding, and call charging reports, to mention just a few.

Additional applications are the provision of secure voice transmission, personal

and private voice mail services, and other existing and planned voice store and forward services such as prerecorded announcements from the home automated functions to the network. By introducing optical fibers into the home, video telephony and other multimedia communications involving simultaneous voice and video can be provided as well. Because of the high data rate characteristic of video, many of these applications require the availability of *broadband* ISDN (B-ISDN), unless the data are highly compressed.

The other data communications requirements of the modern office or home office lead to different category of applications such as text and graphics message communications, including telex, teletex, videotex, facsimile, electronic mail, and video conferencing. Other uses such as local area network (LAN) interconnection, remote access to LANs, PC-to-PC communications, document storage and retrieval, and word processing are also readily supported by the ISDN. Another potential class of applications is to be found in the intelligent home. Important services benefiting from the ISDN features here include building or home access control, security monitoring, smoke detection, temperature sensing and control, energy management, ventilation, HVAC control, and entertainment access and control.

#### 5.2.4 User-to-User Signaling

The principle of functional layering inherent in the open systems interconnection reference model has led to the representation of the total communications capability of a functional group. Both the user-to-user signaling information flows as well as the control information flows are carried over the D channel.

We point out that user-to-user signaling is essentially independent of any other activities. In particular, it may be carried out with or without the existence of a connection over the B channels. In cases where the D channel is required for the

control of a B-channel connection, the user-to-user signaling flow shares the capacity of the D channel and the CCSN (Common Channel Signaling Network) with the control information flow for the connection. It may then be appropriate to impose priorities on the two types of use and to preempt one of the flows when the higher priority flow is present. Care must, of course, be taken to assure that this preemption does not result in a loss of data.

For data communications equipment, the most important of these standards is RS-232D, developed by EIA within the United States and adapted internationally by the CCITT as Recommendations V.24/V.28 and X.21. Other significant designs include the more recent EIA standards RS-422/423/449 and the physical layer of CCITT Recommendation X.21. The home network is assumed to utilize a Carrier Sense Multiple Access with Contention Detection and Contention Resolution (CSMA/CDCR) proposed by the EIA for the CEBus [1], [4].

### 5.3 ISDN Home Information Services

ISDN-based home information system will flower intelligent home such as remote home control, multimedia services including a variety of audio, data, and video services, security monitoring, and energy management. A CEBus gateway could play a key role in the successful connection of ISDN to the home. Fig. 5.2 shows the network structures between ISDN and CEBus. ISDN residential service can be accessed for low speed terminals, personal computers, and digital telephones through the Basic Rate Interface (BRI). For fast facsimile, and slow motion video terminals, the Primary Access Interface may be utilized for ISDN home information systems [94].

An RS232 port maybe used to provide for data to either the CEBus or ISDN employing the appropriate terminal devices and software functions. The gateway

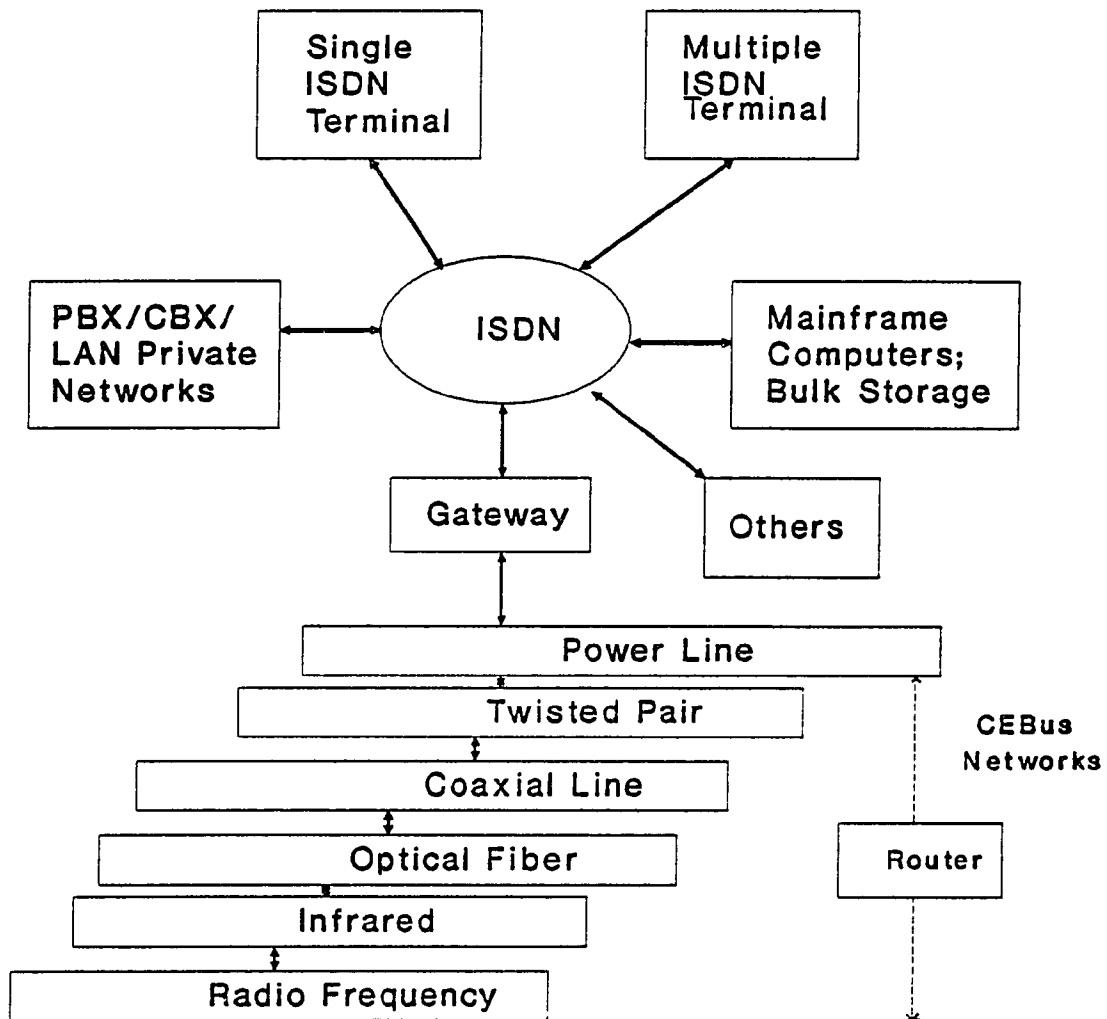

Fig. 5.2 ISDN and CEBus Network Structure.

should provide band rate adaption, signal conversion, buffering and medium access to the network. The CEBus employs the power lines while ISDN uses the telephone line. The gateway function may contain priority access such as high, standard, and deferred. On the ISDN side, higher priority is given to voice communications. This may be accomplished by off-hook detection circuitry. In order to comply with the ISDN requirements, the International Organization for Standardization (OSI)/Open System Interconnection (OSI) reference model can be used as the CEBus gateway toward ISDN. ISDN is actually capable of supporting access to a wide range of services such as voice, data, text, and video by using standard digital network user interfaces [92].

The objective of CCITT (International Telegraph and Telephone Consultative Committee) is to define minimum requirements of interfaces and protocol standards between the access node and the users. As mentioned before, there are two CCITT recommended ISDN interfaces for user access; one is the Basic Rate Interface (BRI), while the other is the Primary Rate Interface (PRI) [98]. The former provides two 64 Kb/s *B* channels for voice and/or data and 16 Kb/s *D* channel for signaling and data; the latter provides 23 or 30 (Europe) 64 Kb/s *B* channels for voice and/or data and a 64 Kb/s *D* channel for signaling. There is also a much higher bandwidth service called Broadband ISDN (B-ISDN) under development, specified as CCITT SG18, intended primarily for video or image data. In the long run extensive the video services, e.g., video-on-demand and high quality teleconferencing and video telephony may be offered to the home. Thanks to the optic fiber-based technologies which can provide enormous amounts of bandwidth high bandwidth video transmission services will be provided by the "Fiber-to-the-Home" (FTTH) technologies [93].

## System Features

According to the definition of “Telematique (Telematic)” given by the CCITT (International Telegraph and Telephone Consultative Committee) recommendation X.1, Telematique CEBus which connects PSTN (Public Switched Telephone Network) terminals and CEBus devices should be the one which facilitates not only the conventional telephone service but the services such as computer data, images and facsimile communications.

### 5.3.1 ISDN Applications for the CEBus

Before we investigate the applicable services of the ISDN to the home, the features of ISDN are described briefly below. The CCITT Common Channel Signaling No. 7 (CCS7) for the ISDN User Part (ISUP) and the Signaling Connection Control Part (SCCP) [95] support end-to-end ISDN communication. The Transaction Capability (TCAP) supports communication between the network switches and the network application nodes. The interworking service for ISDN and CCS7 protocols is provided by the ISDN switches to serve a larger public data network. The ISDN Central Office (CO) will become the information access center for home users, and the Customer Premises Equipment (CPE) will be endowed with advanced digital signal processing and computing technologies for sophisticated home services.

The ISDN capabilities for the ISDN Home Information Services (IHIS) are home information, security, energy management, remote home control/monitoring, call managements, third party access, and video telephony. In home information services, the standardization of the ISDN makes it relatively easy to support the home data users access various information services, e.g. data base access, PC-to-PC communications, and multimedia. By the OSI standard models ISDN based home information systems will be also used for electronic-mail and home-based business as well as home shopping.

For security and energy management ISDN will interface home users to providers such as gas, electric, water and utilities, telephone companies, police, fire department, etc. A bridge may be utilize to send data bidirectionally.

*Remote control/monitoring* service will bring data to and from the home to monitor, change, and otherwise control the status of various appliances and systems from a remote terminal or ISDN equipment. The residential customers can also monitor and control their home security status or appliance conditions by using a remote telephone or data terminal.

*Call management* services capability is the feature in telecommunications management provided by the PTN (Public Telephone Network) and new ISDN system. The call management services will have the ability to selectively accept, reject, block, or identify the caller. Lin [96] [97] has proposed expanding the number of voice channels from two to four in a basic rate interface by using Adaptive Differential Pulse Code Modulation (ADPCM) transcoding scheme in order to provide a virtually non-blocking voice communications for ISDN residence users.

*Teleservice Access* is a mechanism that allow the outside users to access home devices for remote meter reading, remote ticketing and home shopping as well as home banking. This ISDN capability will allow an outside user to call into the home and retrieve information from connected devices or appliances in the home. As an important example, a home device will transmit data generated by utility meter encoder to the servicing companies as requested.

*Video Telephony* has two major applications, the two-way video telephone and the video conference. Multimedia services based on the ISDN features are capable to support simultaneously the transmission of voice, audio, data, and video or still images. ISDN-based-home information systems will provide continuous monitoring and auto-dial out. This service capability requires the home surveillance device to evaluate the security conditions, and initiate auto-dial (or auto calling) out following

preprogrammed scenarios. A 64 Kb/s channel can provide acceptable quality video telephony [94].

In the future the *Intelligent Network* (IN) will offer modular functionality, which will allow adjustments in response to varying traffic demands and user requirements. The IN [102] will support various advanced network-based services in which network elements are interconnected by data communication links, such as CCS7 (Common Channel Signaling #7) and X.25. The functions that are currently being developed include N911, Voice mail system, Electronic directory, Fax catalog, and 800 Information Forwarding service for Pay-Per-View Cable Television [94].

### 5.3.2 Gateway Wiring and ISDN Home Informations System Architecture

ISDN based home informations system will need to accommodate multimedia information service through gateways to other media and devices. Included in the gateway capabilities is the ability to convert terminal keypress sequences into commands, and to transmit the generated those commands to the appropriate media. On the side of the CEBus network, the gateway is required to convert ISDN data into pulse width modulation (PWE) signals. A Home Network Controller (HNC) may be located inside the Distribution Device (DD), as shown in Fig. 5.3. As shown in (a), the HNC is connected to one passive bus and shares the passive bus with other ISDN terminals. As shown in (b), the HNC is serially connected to the Network Termination. The DD (Distribution Device) contains the necessary means for connection of TP1-3 to the same TP1-3 in other branches of the network.

The HNC supports both an ISDN port and an analog port. In the two wiring configurations the second one may be preferred because of installation of its flexibility; the DD can be installed at the entrance of the house, in the basement, or in the utility room. Another advantage in the second wiring configuration is that all the system



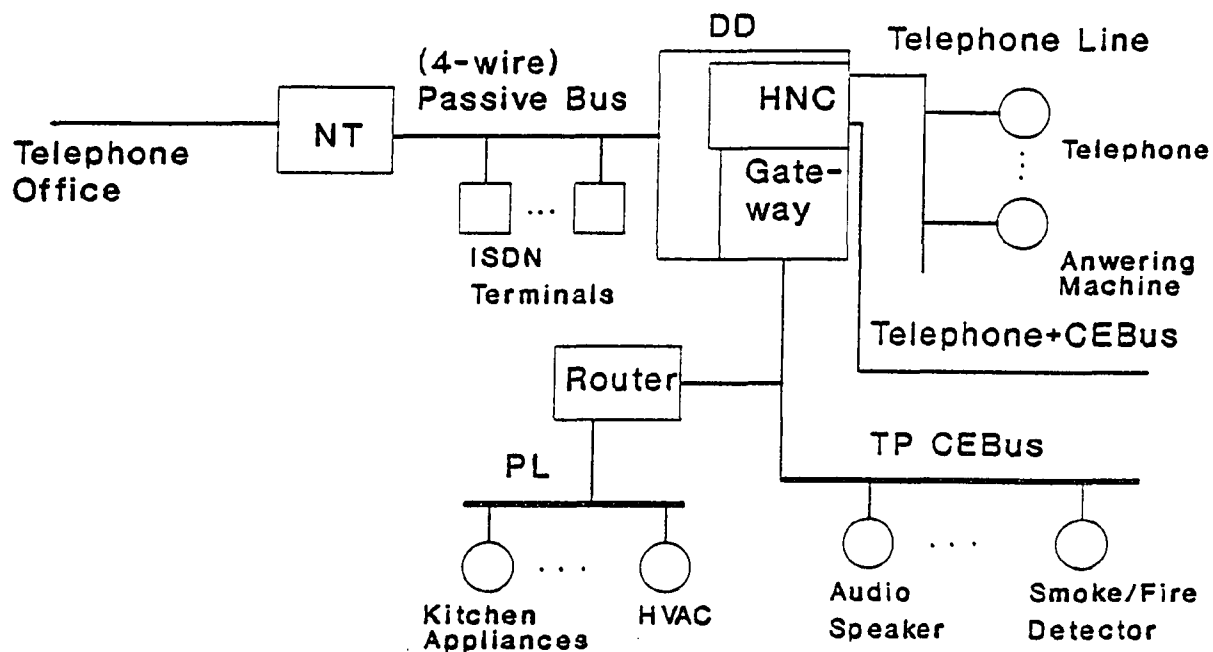

(a) Wiring In-Parallel with a NT

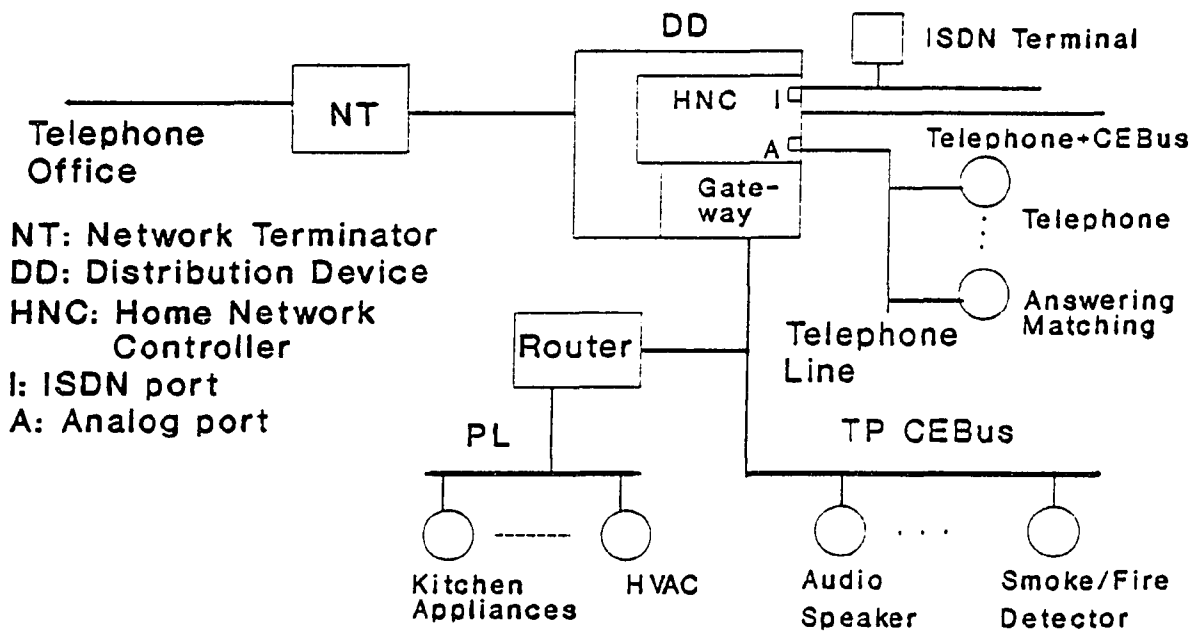

(b) Wiring Serially Connected to a NT

Fig. 5.3 Distribution Device with a NT.

features can be centralized in the DD and HNC. The HNC may contain some common components that serve all of the system's functionalities such as the system's single touch-tone generator, global line status, ring detectors, and ISDN protocol circuit. The HNC can also route the incoming call to the particular remote station and ring the called station or send messages. An incoming call can be broadcasted to all stations by the Directory Number (DN) of the HNC or Routing Tables of the Gateway.

The BRI wiring of the home network ISDN can adapt the point-to multipoint configuration. A point-to-multipoint wiring configuration allows more than one Terminal Equipment (TE) to be simultaneously active at an S or T reference [98] point. The *passive bus*, which is a four-wire bus, could provide the ISDN BRI point-to-multipoint wiring configuration.

In the future, the fiber optics technology will allow the connection of the home automation network attached to narrow-band ISDN (BRI and PRI) to broadband ISDN. These High quality video and high speed data access will be provided by the fiber optics networks.

## 5.4 CEBus Gateway Design and Its Interface to the ISDN

To execute various communication services between the CEBus and PSTN (Public Switched Telephone Network), an interface is required to convert signal schemes and to control different data rates. Since the CEBus terminals are generally isolated from those of PSTN or ISDN, and different from PSTN in their transmission method, it is impossible to communicate with each other without signal conversion. So a converter, i.e., a gateway to which a control channel communication protocol is incorporated, is required. This aspect will be described in detail later.

A slightly more difficult problem is the implementation of the speed match be-

tween the CEBus and the ISDN networks. If a terminal on the ISDN system sends a large number of packets into the home, i.e., CEBus, the packets may arrive at the gateway much faster than the gateway can pass them on to the home information network(CEBus). Even if the data rates of both sides (home and ISDN side) are the same, the home side (CEBus) itself is effectively about 1.5 times slower than the ISDN network. The reason is that one bit of the CEBus protocol has duration of 1 or 2 USTs. This randomizes the frame duration. Thus 1 bit of the layered system needs on average a time length of 1.5 USTs or approximately 1.5 bits on the network.

Some mechanism will be required to prevent the gateway from exhausting its buffer space or to provide enough buffer size to compensate the different data rate or transmission speed. It leaves unanswered the question of how additional features may be implemented, such as complex flow control, protocol conversion, and buffering management. The development of a number of computer networking technologies has been driven. The differences in both requirements and environments between designs. From the point of view in the layered protocol architecture, a gateway should provide a network protocols and internet protocol. At present, the International Standards Organization (ISO) adopts X.25 as their main network sublayer, and has proposed their own protocol for the transport layer [104], [105]. The TCP is currently used as a transport protocol, the IP as an Internet protocol and X.25 as the network protocol in a manner which mirrors the ISO proposals. Although X.25 is a virtual circuit interface protocol, X.75 [107] is an interface intended for use between public networks. A paper [106] presented a conversion strategy between the TCP and ISO Transport protocols as a method of achieving interoperability between data communications systems

Even if, in a gateway design, there may be many possible protocols and schemes, in this scenario, ISO-based ISDN is assumed for the CEBus-based home network. Thus when the signal of the CEBus network flows to the ISDN, or vice versa, the gateway has a capability to convert the four layered architecture of the CEBus to the

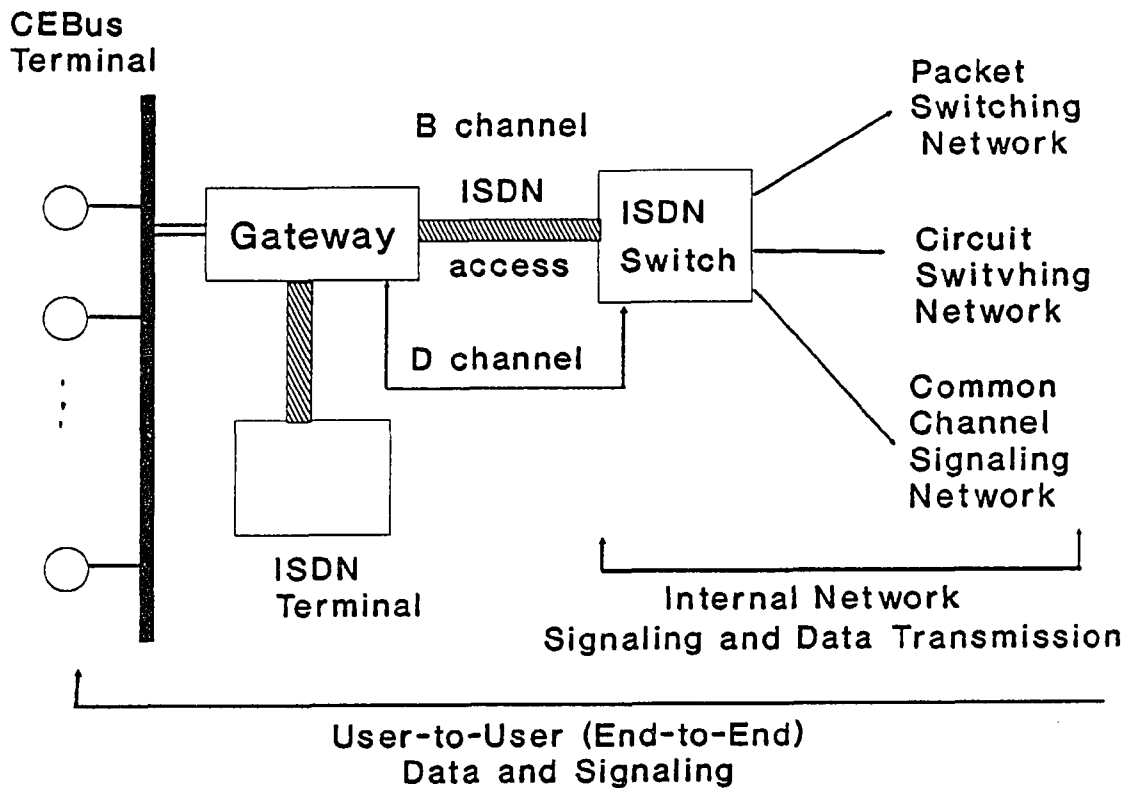

Fig. 5.4 Data and Signaling Interface between the CEBus and the ISDN Networks.

7 layer ISO reference model for the ISDN, or vice versa.

Gateway development is complex because of dissimilarities between the two architectures. Despite superficial similarities, their implementations include radical differences:

- The CEBus employs 4 layers (AL, NL, DLL, PL), whereas ISDN network users 7 layers.
- At the DLL layer level the CEBus uses PWE encoding signal, which ISDN does not support.
- At the equivalent layers of the OSI network, the CEB provides connectionless service but ISDN provides connection-oriented service.

Fig. 5.4 shows ISDN data and signaling interfaces between user equipment and network. As the figure indicates, the user will be given more control over the network by being given access to signaling functions. User signaling will be transmitted via

the D or E channels, with data usually transmitted via B (or H for broad bandwidth) channels. The common channel signaling facilities are available only to the network provider.

## 5.5 Simulation Network Model

In the simulation model, a gateway between the CEBus and the ISDN is utilized. It is used to convert CEBus signals to ISDN ones and vice versa. It provides 16 Kb/s for the ISDN network and 10 K ONE bit/s for the home CEBus network. Simulation has been performed using the LANSF, a protocol modeling environment system for investigating the performance of communication networks [83]. The LANSF, written in C, runs under UNIX.

The simulation network model is shown in Fig. 5.5. The service discipline for messages originating from ISDN sources towards the CEBus network is first-in, first-out, i.e., FIFO, for each priority. However, higher priority messages will take precedence over all lower ones, while the latter are waiting in the buffer. The buffer size of the router as well as that of each node is assumed to be of infinite capacity. The Gateway is assumed to have three buffers, one for each priority, on each of its two sides, the one attached to the ISDN and the other serving the CEBus network. Thus the messages originated from the ISDN and/or from the CEBus networks access the channel according to their priority, i.e., higher priority messages will be transmitted first.

The propagation delay between the instant packet is sent out from the ISDN side towards the home the generation of an incoming signal to the CEBus is assumed to take either 0, 1, or 5 bits, i.e., 0 sec, 62.5  $\mu$ s, or 0.31 ms. End-to-System delays of the ISDN network such as connecting, switching, and processing times are not specifically included in this simulation. However, those times may be added on to the simulation

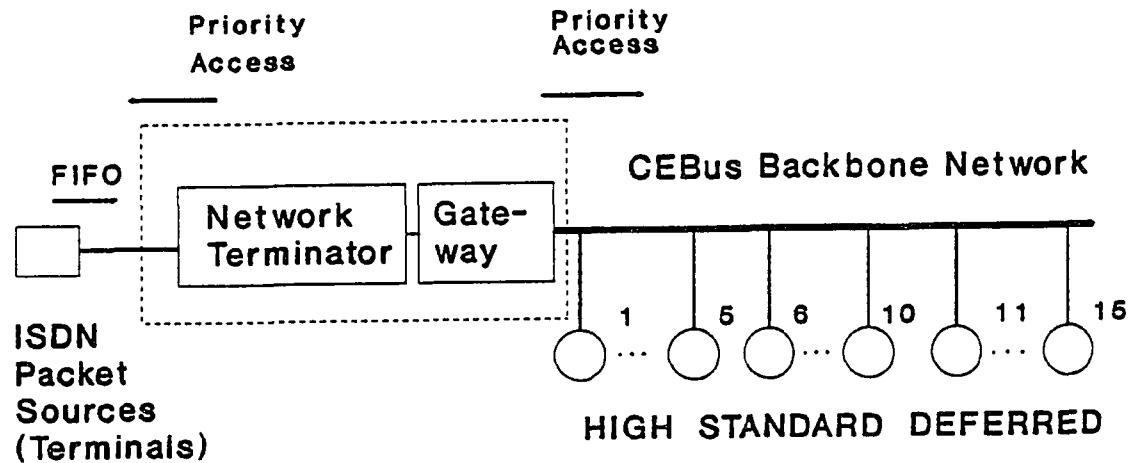

Fig. 5.5 Network Simulation Model through the Gateway.

experiment results based on the literature [100]. As an example, the literature [100] shows mean delay of about 70 *ms* utilizing a link with capacity 56 Kb/s and data length of 500 bits at traffic intensity 0.65. If we include the ISDN processing time, the total delay time may be computed by adding a delay value of about 70 *ms*, adjusted somewhat according to the traffic load as it differs from the 0.65 value of the traffic intensity. We can also refer to the literature [101] for studies of the delay of the ISDN D-channel access protocol. It has been shown that there is a mean signalling delay of approximately 900 bits when the packet and signal utilization value is about 0.4.

According to the protocol recommended by CCITT for ISDN, the basic access structure of the user-network interface consists of two B-channels, each operating at 64 Kb/s, and one D-channel operating at 16 Kb/s. The primary function of the D-channel is the transmission of the signalling messages needed for the control of the circuit-switching in the B-channels. Telemetry (remote home control and/or remote

home utilities measuring) and low-speed packet messages may share the D-channel with the signalling messages.

### A. Traffic Patterns;

The traffic patterns are given in two cases; case 1 utilizes as the packet lengths of 200 bits while case 2 employs a length of 1,000 bits for both networks. This includes the header as well as control information. Each priority message is generated with the same probability, that is, each priority takes 33.3% of the offered load.

The offered traffic load is categorized into three groups, i.e., (a) from the ISDN to the CEBus/PL ( $I \rightarrow C$ ) direction, (b) from the CEBus/PL to the ISDN ( $I \rightarrow C$ ), and (c) from the CEBus/PL to itself. Here, (a) and (b) make up the inter-network traffic, while (c) is the intra-network traffic. The three priorities use the same ratio of packet generation and attempt channel access to their destination. In other word, the offered load is assumed to be symmetric for each group, i.e.,  $g_{PL \rightarrow PL} = g_{PL \rightarrow ISDN} = g_{ISDN \rightarrow PL}$ .

The CEBus backbone network is considered to be the power line bus. The number of stations for each priority is 5 for a total of 15 on the CEBus. It is also assumed that the frame information length is 10 while the preamble length is 8 bits. In comparison to the delay incurred in travelling the distance between the outgoing point (telephone office) of the ISDN and the incoming point (home) at the CEBus, the propagation delay incurred for a packet while moving around in the home toward its destination on the CEBus network may be quite reasonably assumed to be zero, for all practical purpose. The packet length utilized is 200 bits. Most often the packet length employed for the ISDN network is 1,000 bits; in fact it has been shown that the optimum packet is 1,200 bits [103]. However, the optimum packet format of the CEBus [4] uses a length which is less than 400 bits, i.e., preamble 8 bits, control 8 bits, destination address 16 bits, destination house code 16 bits, source address 16

bits, message information varying up to 32 bytes, and cyclic redundancy check 16 bits. An additional reason to choose the CEBus packet length equal to 200 bits is that the CEBus channel capacity or data rate is rather low, 10 Kb/s.

The offered traffic pattern is given by identical or symmetrical arrival rates, i.e.,  $\lambda_{PL \rightarrow PL}^p = \lambda_{PL \rightarrow ISDN}^p = \lambda_{PL \leftarrow ISDN}^p = \lambda_X^p$ . Here  $\lambda_{PL \rightarrow PL}^p$  is the arrival rate of priority  $p$  for the intra-network traffic on the Power Line (PL) medium, while  $\lambda_{PL \rightarrow ISDN}^p$  is the arrival rate of priority  $p$  for the inter-network messages flowing from the PL to the ISDN. The  $\lambda_{PL \leftarrow ISDN}^p$  indicates the reverse direction. The traffic load is calculated in terms of arrival rates as follows:

$$\begin{aligned}
 g_{PL \rightarrow PL} &= 3\lambda_{PL \rightarrow PL}^p \frac{L_p}{c} \\
 g_{PL \rightarrow ISDN} &= 3\lambda_{PL \rightarrow ISDN}^p \frac{L_p}{c} \\
 g_{PL \leftarrow ISDN} &= 3\lambda_{PL \leftarrow ISDN}^p \frac{L_p}{c} \\
 g_{PL} &= g_{PL \rightarrow PL} + g_{PL \rightarrow ISDN} + g_{PL \leftarrow ISDN}
 \end{aligned} \tag{5.1}$$

Here, superscript or subscript  $p$  indicates one of the three priorities. The packet length is denoted by  $L_p = L_H = L_S = L_D$ , where priority High, Standard, and Deferred is indicated by H, S, and D, respectively.

**B. Performance Measures.** The delays and throughputs are measured as follows:

- **Message Delay** is measured as the time elapsing since the message was queued at the sending node to the moment the entire message is successfully received at the destination (including the message queuing time).
- **Packet Delay** is measured as the time elapsing since the packet became ready to be transmitted to the moment the entire packet is successfully accepted at its destination.
- **Message Throughput** is calculated as the ratio of the total number of bits re-



ceived at the destination address to the number of bits generated at the source.

- **Channel Throughput** is measured as the ratio of the total number of bits received through the link to the simulation time. This throughput reflects not only the bits that are received on the link for intra-network traffic, but also the bits that are successfully received at the destination for inter-network traffic.

## 5.6 Simulation Measurements

In the simulation experiments, the propagation delay on the CEBus was ignored while it was included in the considerations of inter-network traffic from the ISDN to the CEBus network. As mentioned before, all the offered loads for the three priority levels and the three traffic groups are configured symmetrically. Also, the channel throughput is normalized to the CEBus channel capacity.

Fig. 5.6 illustrates message and channel throughput on the Power Line of the CEBus (CEBus/PL) as a function of offered traffic load for packet of length 200 bits. On the Power Line (PL), when the offered load, including inter-network traffic through the gateway reaches the 3.0 of the traffic load, the HIGH priority message throughput for intra-network traffic starts to decline, while the DEFERRED priority message throughput starts to decline sharply at 0.75 of the offered load. The channel throughput on the PL increases monotonically until it reaches the maximum value of 0.88, in which occurs for the offered loads in the a neighborhood of 1.2. After that, the channel throughput starts to decline slightly due the greater number of collisions resulting from the increased number of simultaneous attempts of transmission.

Fig. 5.7 shows the message throughput for inter-network traffic through the gateway versus offered load for the ISDN to the CEBus/PL direction and reversely; here the packet length is 200 bits and there is zero propagation delay. On the whole, inter-network traffic generated from the ISDN source and arriving to the CEBus

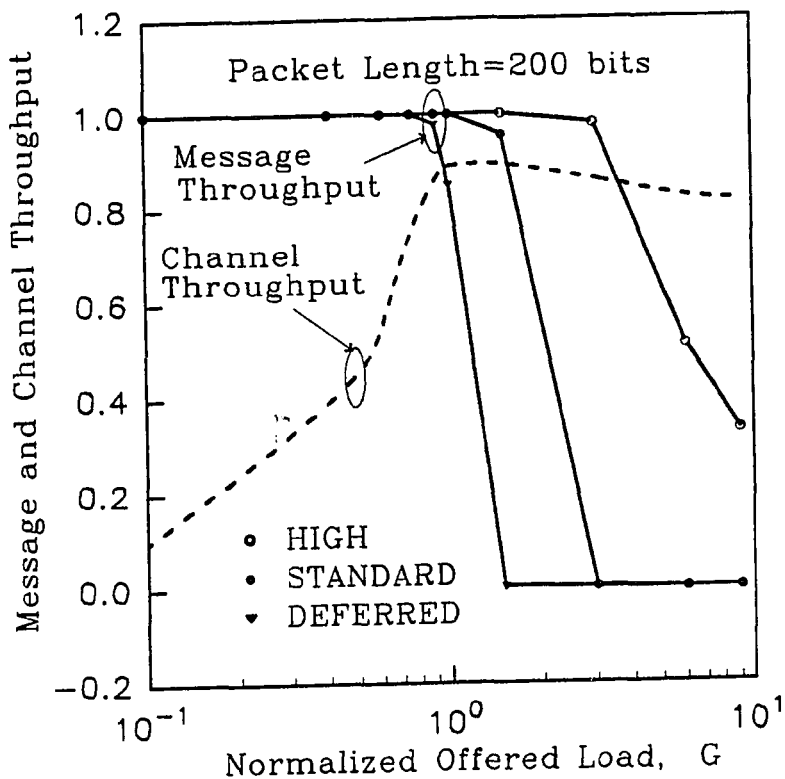

Fig. 5.6 Message and Channel Throughput versus Normalized Offered Load with Packet Length 200 bits on the CEBus.

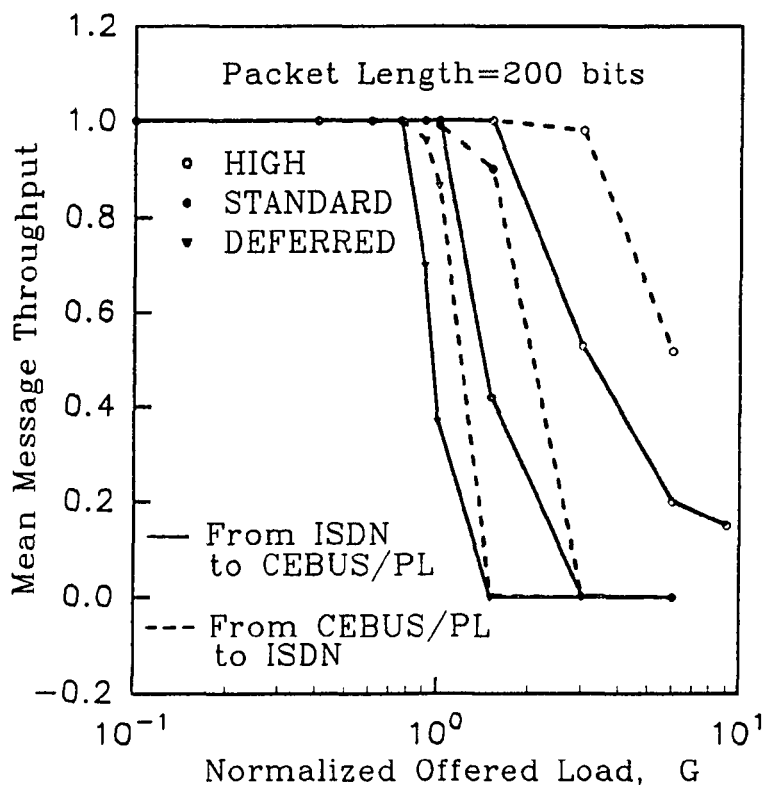

Fig. 5.7 Mean Message Throughput versus Offered Load for Inter-network Traffic from ISDN to CEBUS/PL and vice versa with Zero Propagation Delay.

shows lower throughput than that of the reverse direction. This is especially true for STANDARD and DEFERRED priority message for inter-network traffic which manifest lower throughput than those of intra-network traffic when the offered load is larger than 90% of the network capacity.

Fig. 5.8 shows the mean message delay for inter-network versus traffic load from the CEBus to ISDN ( $C \rightarrow I$ ) and vice versa with 200 bits packet length and zero propagation delay. For the most part, the messages for  $I \rightarrow C$  direction show higher delay than those of the reverse direction under heavy load. This reason is that the ISDN side has only one port toward CEBus while the CEBus has three ports for three priority messages. So, the messages in one port may have less opportunity to transmit than those in three ports. However, in traffic load less than 70% of the channel capacity, the messages arriving from ISDN to the CEBUS/PL ( $I \rightarrow C$ ) show lower delay than that of the reverse direction traffic. When 200 bits are utilized for the packet length, the minimum delay (zero load) is 50 ms for inter-network traffic through the gateway.

In Fig. 5.9, the mean message and packet delays for intra-network traffic are plotted in terms of the offered load. Until the normalized offered load reaches about 0.4 in total, we find that the message and packet delays are small and bounded.

The delay in HIGH priority for both packet and messages remain close to each other until the offered load reaches about 1.5 at which point the values of delay diverge sharply; as the traffic load increases further, the packet delay for channel access increases mildly while the message delay which includes queueing delay in the buffer approaches infinity. Generally, message delay reaches much higher values than packet delay of the same priority in heavy traffic load, as shown in Fig. 5.9.

Fig. 5.10 illustrates channel and message throughput as well as mean message delay as a function of the offered load with no propagation delay when the packet length is 1000 bits. The maximum channel throughput reaches the value of 0.97. In

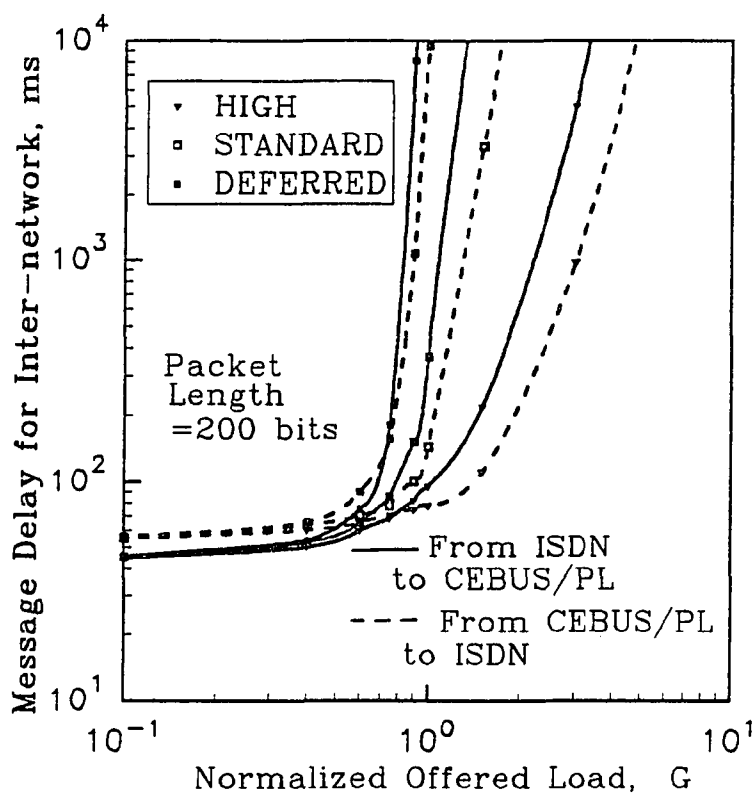

Fig. 5.8 Mean Message Delay for Inter-network Traffic versus Normalized Offered Load from CEBUS/PL to ISDN and vice versa with Zero Propagation.

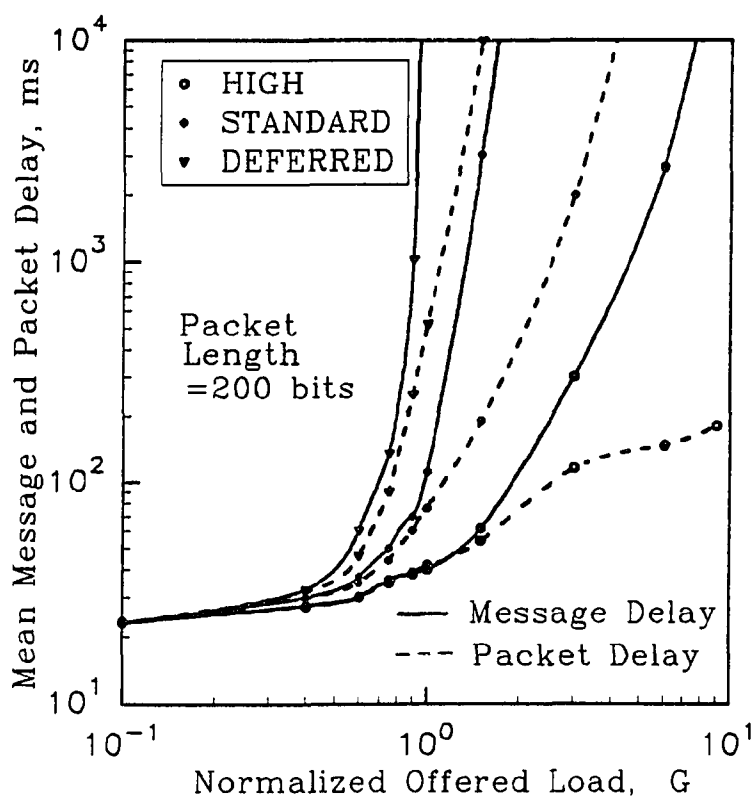

Fig. 5.9 Message and Packet Delays versus Offered Load for Intra-network Traffic on PL Medium with Packet Length 200 bits and Zero Propagation Delay.

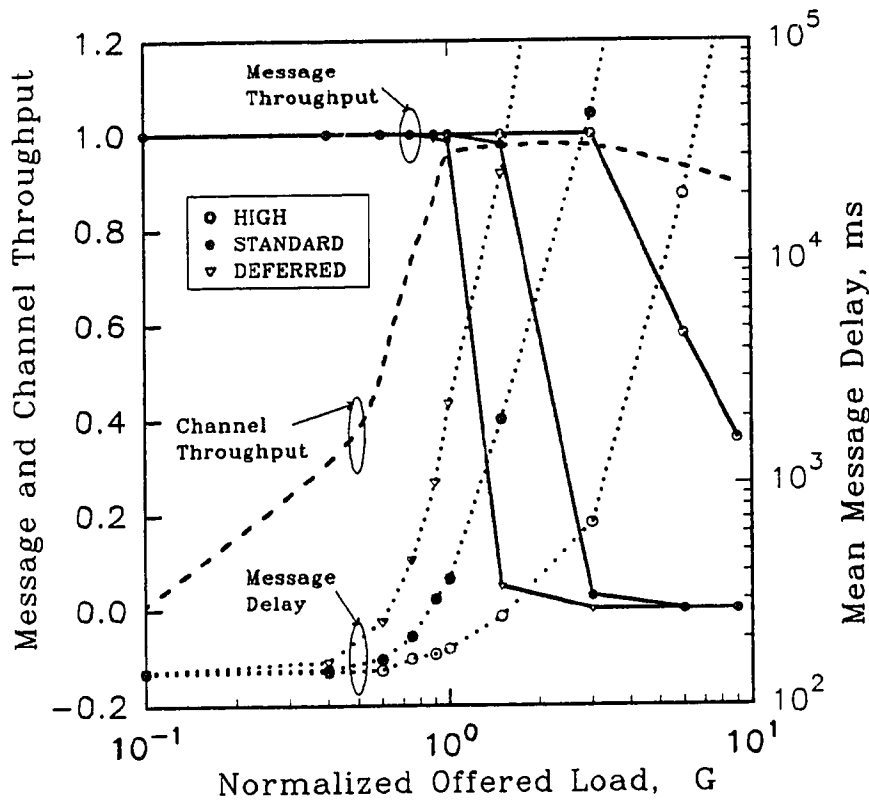

Fig. 5.10 Channel and Message Throughputs, and Message Delay for Intra-network Traffic on PL Medium versus Normalized Offered Load with Packet Length 1,000 bits and Zero Propagation.

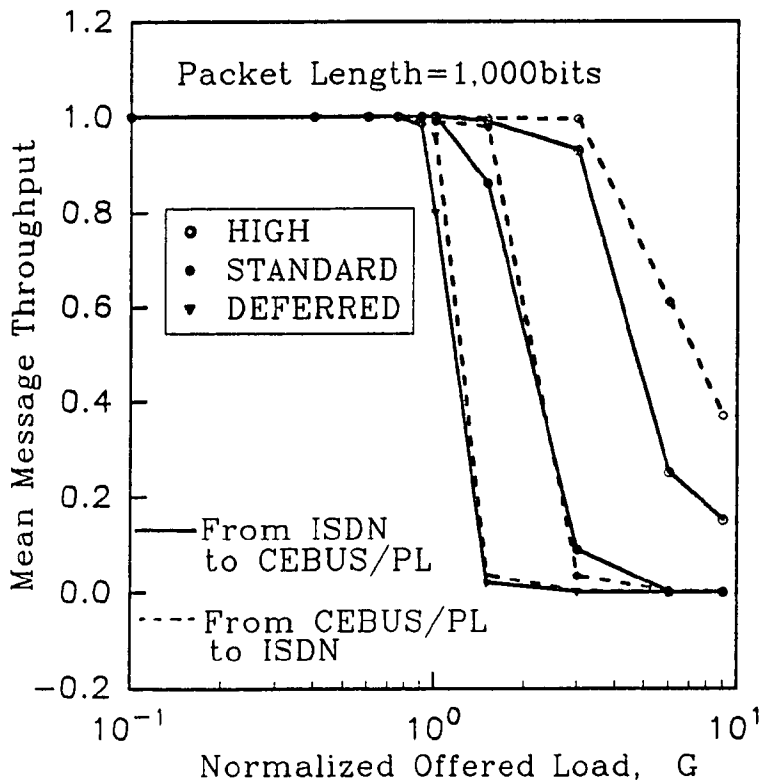

Fig. 5.11 Message Throughputs for Inter-network Traffic from ISDN to CEBus/PL and vice versa as a function of Normalized Offered Load with Packet Length 1,000 bits and Zero Propagation.

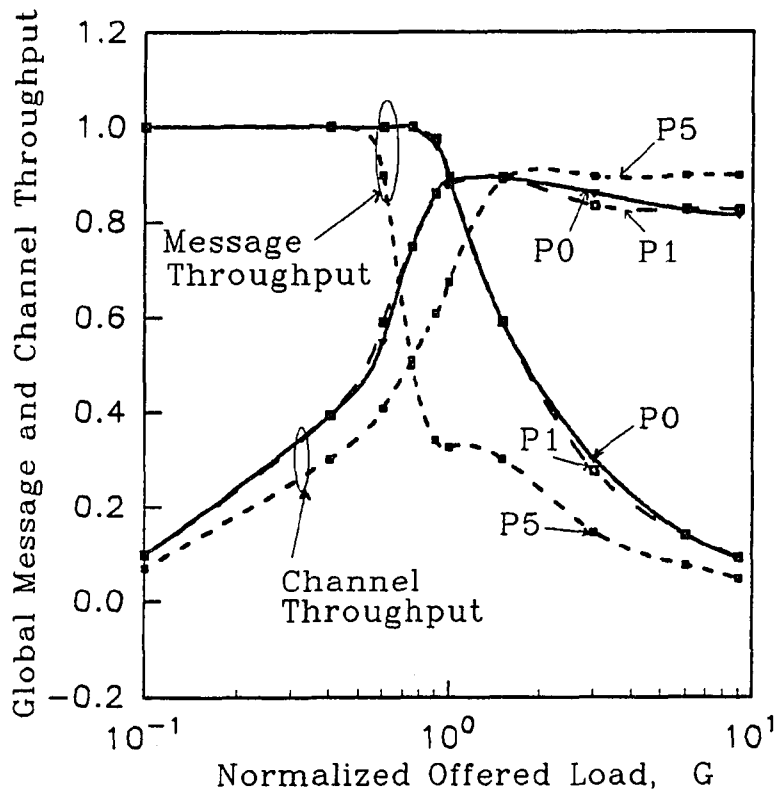

Fig. 5.12 Global Message and Channel Throughputs versus Offered Load for Intra-network Traffic on PL Medium with Packet Length 200 bits and Different Propagation Delay. (a)  $P_0 = 0$  bit, (b)  $P_1 = 1$  bit, and (c)  $P_5 = 5$  bits.

fact throughput remains very high between the values of 1.0 and 3.0 of the offered load, and then it starts to decline slowly due to collisions. In comparison with the throughput for packet length 200 bits, shown in Fig. 5.6, the channel throughput here is higher thanks to the large packet length in relation to the channel capacity. Even though the channel throughput increases, it is not advantageous to rely on larger packets because the number of transmissions per unit time, i.e., the frequency of message delivery drops drastically and delays rise sharply. The message throughput shows a similar distribution to the case which employed 200 bits packet length.

In light traffic load, less than 40% of the channel capacity, it takes 100 - 200 *ms* in order to deliver a intra-network message of 1,000 bits on the PL medium regardless of the priority, whereas it takes 20 - 30 *ms* for 200 bit packet length within the PL medium, as shown in Fig. 5.9. At offered load of 75% of channel capacity, the HIGH priority message shows 150 *ms* delay, the STANDARD priority message shows 200 *ms*, while the DEFERRED one goes up to 500*ms*. As the load increases further, the

delay of lower priority messages increases greatly in comparison to higher priority.

Fig. 5.11 shows the mean message throughput for inter-network traffic through the gateway as a function of normalized offered load when the packet length is 1,000 bits and the propagation delay is zero. In general, message throughput for  $I \rightarrow C$  is somewhat smaller than that for  $C \rightarrow I$  because ISDN side has only one port toward the CEBus while the CEBus side has three ports for each priority toward the ISDN.

At 9.0 of the offered load, the  $I \rightarrow C$  throughput for HIGH priority message shows 15% successful transmission HIGH priority messages, while the  $C \rightarrow I$  shows 35%.

In Fig. 5.12, global message and channel throughput are plotted as a function of traffic load, with propagation dealt as a parameter between ISDN and CEBus when the packet length is 200 bits. In the figure, P0 represents 0 propagation delay, P1 represents 1 bit delay, i.e.,  $62.5 \mu s$  delay, and P5 represents 5 bits, i.e.,  $0.31 ms$  delay. It is found that the channel and message throughput are affected quite strongly by propagation delay, as shown in Fig. 5.12. Generally, the channel throughput shifts to the right, and for a given offered load, the channel throughput declines as propagation delay increases. Global message throughput, defined as all messages of all priorities arrived to the destination divided by all messages generated from all stations, is also sensitive to propagation delay. The global message throughput in case of P5 starts to decline earlier at about of 0.5 of offered load, while the P0 and P1 cases are only slightly affected and show similar distributions.

Figs. 5.13 and 10.14 show mean message throughput for inter-network traffic through the gateway as a function of offered load, for three propagation delay values, when the packet length is 200 bits. Fig. 5.13 shows the throughput  $I \rightarrow C$  message traffic while Fig. 10.14 depicts the case of  $C \rightarrow I$  message transmission. The probability of successful  $I \rightarrow C$  message delivery is lower than that of  $C \rightarrow I$  message delivery in heavy traffic load. The reason may be that outgoing message from the ISDN

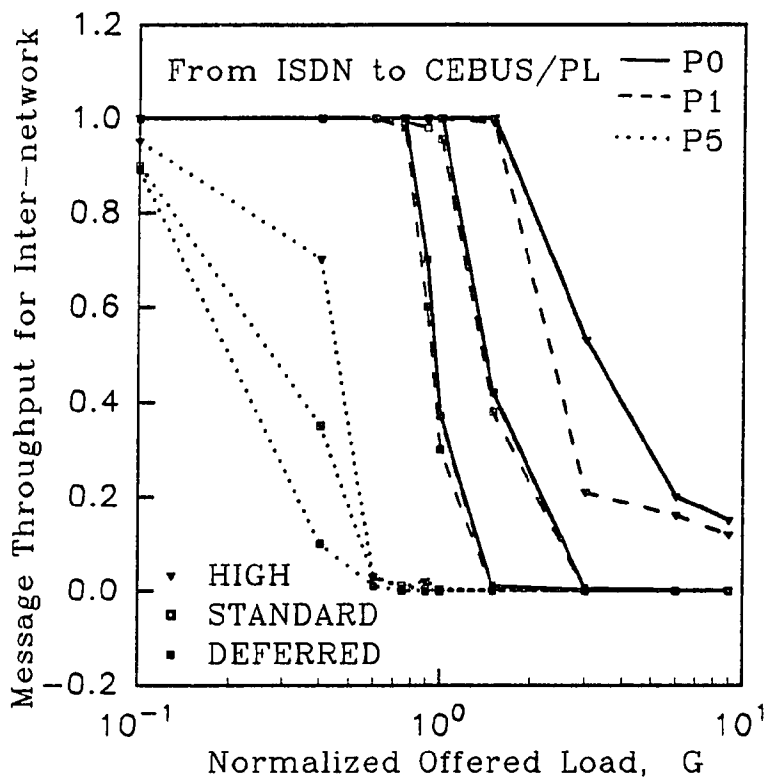

Fig. 5.13 Message Throughput through Gateway from ISDN to CEBus as function of Normalized Offered Load with Packet Length 200 bits and Different Propagation.

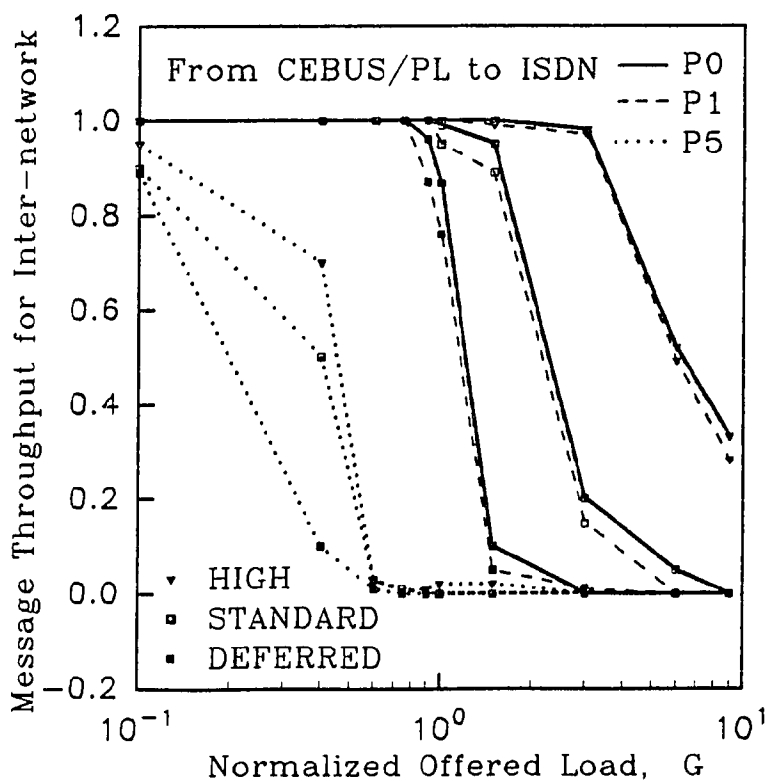

Fig. 5.14 Message Throughput through Gateway from CEBus to ISDN as function of Normalized Offered Load with Packet Length 200 bits and Different Propagation.



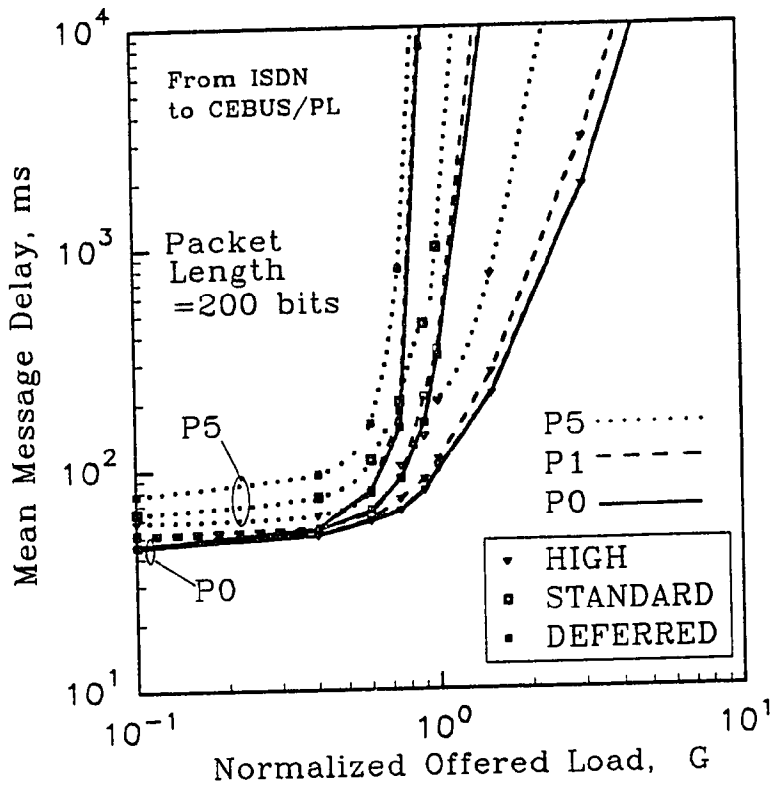

Fig. 5.15 Mean Message Delay through Gateway from ISDN to CEBus as function of Normalized Offered Load with Packet Length 200 bits and Different Propagation.

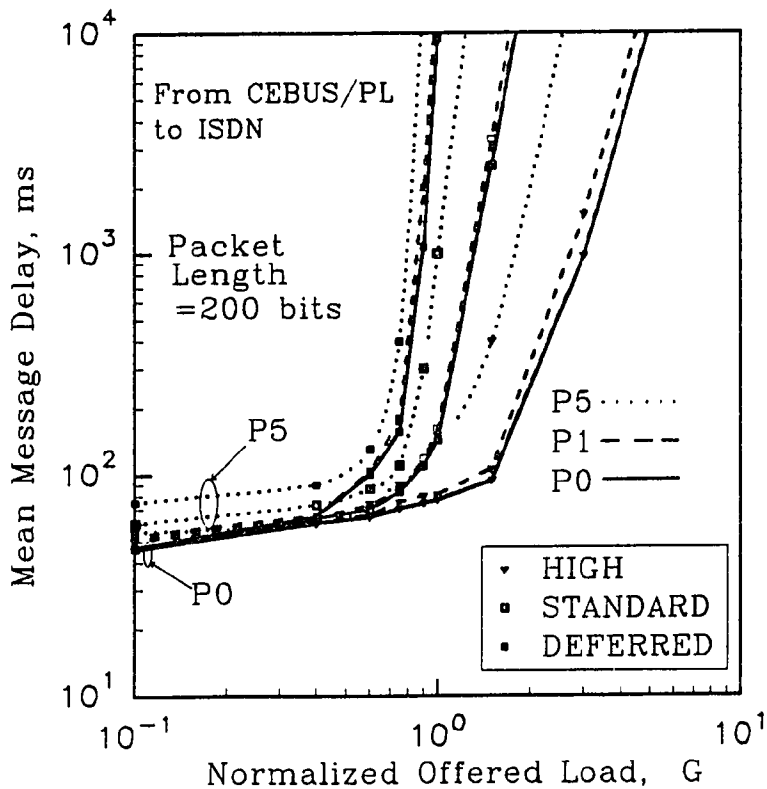

Fig. 5.16 Mean Message Delay through Gateway from CEBus to ISDN as function of Normalized Offered Load with Packet Length 200 bits and Different Propagation.

to the home  $I \rightarrow C$  all utilize has one port even if the higher priority message takes precedence over lower one in a buffer (but no preemptive scheme), while the gateway toward the ISDN has three ports for each priority to access medium. Besides, each priority message for  $C \rightarrow I$  may be ready to transmit a packet from each station and the gateway toward ISDN in comparison to one port of ISDN toward CEBus even though the gateway for  $I \rightarrow C$  direction message has three ports to access the PL medium. When it takes 5 bits (0.25 *ms*) in the distance between the ISDN and the CEBus, the message throughput deteriorates sharply and greatly due to a very high collision probability even if the offered load is low.

Fig. 5.15 and 5.16 depict the behavior of mean message delay for different propagation delays between the ISDN and the CEBus with packet length 200 bits. Fig. 5.15 shows the  $I \rightarrow C$  inter-network traffic through the gateway, while Fig. 5.16 gives the  $I \rightarrow C$  traffic. For 1 bit delay, since the propagation delay is much smaller than the packet transmission time, the ratio  $a$  of propagation delay to packet transmission time is a very small quantity, on the order of 0.005. In this case there is little difference with the results of zero propagation delay case. However, for 5 bits propagation delay,  $a$  is about 0.025 and now the delay and throughput performances deteriorate greatly. In order to show the behavior of message delay in low traffic the lower left corner of Fig. 5.15 is magnified and shown in Fig. 5.17. As the propagation delay increases, the message delay also increases initially. Moreover, delay increases as the priority gets lower. The delay may be large even in light offered load for low priority and large propagation delay.

## 5.7 Summary

A wide variety of schemes for allowing nodes to gain access to a local area network have been proposed, analyzed, and implemented by numerous researchers. These protocols

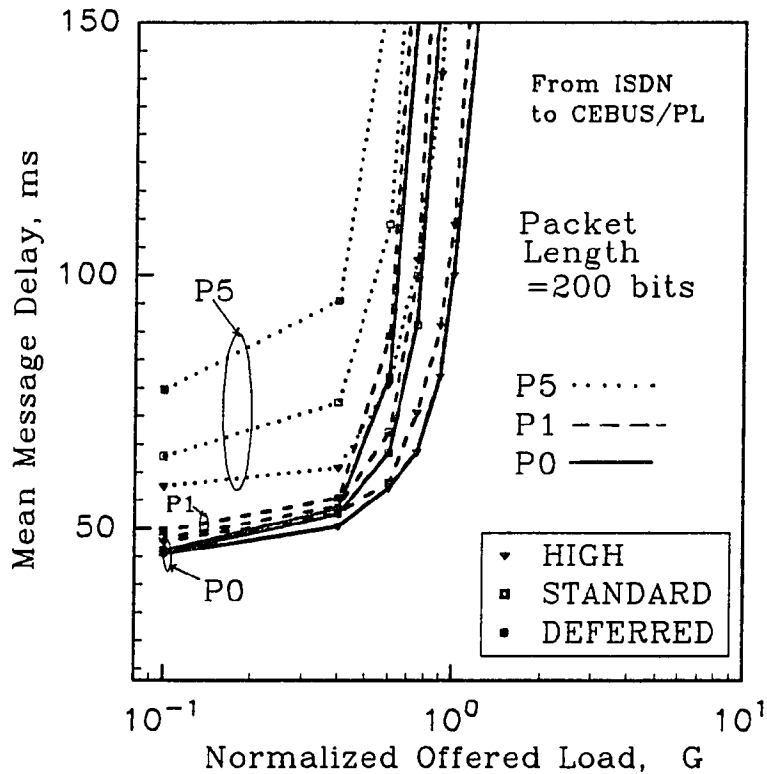

Fig. 5.17 Mean Message Delay through Gateway from ISDN to CEBus as function of Normalized Offered Load (magnified from Fig. 5.15).

may be generally classified as contention methods (or random access techniques) or controlled (or deterministic) methods. In this chapter, a Carrier Sense Multiple Access with Contention Detection and Contention Resolution (CSMA/CDCR) is used for the home network, CEBus. A gateway is incorporated which handles three priority class messages for either directions. The gateway connects the CEBus to ISDN. The ISDN side sending messages to the CEBus has one port, which is assumed to use a priority scheme, so high priority messages are taking precedence over lower priority messages in a infinite buffer.

The main performance considerations for a LAN are the packet/ message throughput, the channel utilization and the delay characteristics. In this simulation, message and channel throughputs and packet and message delays have been studied in terms of the offered load for intra-network traffic in the CEBus and inter-network traffic to ISDN through the gateway.

It has been observed that the maximum achievable throughput was increased

from 0.89 to 0.97 as the packet length rose from 200 bits to 1,000 bits. However, in increasing packet length it was found that the the performance of message delay deteriorated. The delay of 200 bit packets was found to be about 20 *ms* to 30 *ms* for intra-network traffic within the CEBus. As a result of simulation experiments, when we design the system, the packet length and the packet format should be determined considering network performance metrics, such as delay and throughput.

It has been shown that delay for inter-network traffic for any priority level is much higher than at of intra-network traffic due to waiting time in the buffers of the gateway and the different data rates existing between the ISDN and the CEBus sides of the gateway. On the whole, the delay from the ISDN to the CEBus direction has shown lower delay than that from the CEBus to the ISDN in light traffic load. However, in heavy traffic load, larger than 70% of network capacity, message traffic from ISDN to the CEBus experienced higher delay than in the reverse direction.

We have studied the network sensitivity to the propagation delay, or, equivalently, the distance between the telephone office in which the ISDN system is installed and the house in which the gateway and CEBus are installed. The overall, global message throughput was observed to decline sharply at about 50% to 60% of the channel capacity for large propagation delay 5 bits or 0.31 *ms*, while the global message throughput started to decline at about 90% of the capacity when there was no propagation delay. Small propagation delay (1 bit or 62.5  $\mu s$ ) gave simulation results to almost zero propagation delay. It is generally recognized that system utilization or channel throughput deteriorate for longer propagation delay. This is especially true for message throughput for inter-network traffic for any priority. In such cases, extremely low successful delivery to the destination has been found, as well as large delay time due to collisions owing to the high propagation delay.

Therefore, a residence which is located a long distance away from the office providing ISDN services, so that large propagation delay is expected, may require an

acknowledgement from repeaters instead of end-terminal acknowledgement, different frequency bandwidth for transmission and reception, or hybrid circuits on the gateway and the outgoing stage of the ISDN, respectively. Under ideal situations, i.e., for zero propagation delay, proper packet length such as 300 to 500 bits approximately, and light traffic less than 70% of the offered load (including inter-network traffic via the gateway), the simulation has shown that the CEBus system interconnected by the ISDN behaves well without deteriorating system performance.

# CHAPTER 6

## CONCLUSIONS

### 6.1 Research Summary

In this dissertation an extensive investigation of the Consumer Electronics Bus, a computer network for the intelligent home has been carried out. This study has included theoretical analyses and simulation experiments. A numerical analysis of a mathematical model of the CEBus protocol based on the Carrier Sense Multiple Access with Contention Detection and Contention Resolution (CSMA/CDCR) has been carried out. In addition, a three priority router, connecting the Twisted Pair (TP) to the power line (PL) physical medium, have been studied and their performance evaluated. Moreover, a gateway connecting the CEBus to ISDN has been designed and evaluated.

The architecture of the CEBus, its protocol, and its layers and their functions have been presented briefly.

In order to handle the resolution of collisions, several approach methods have been studied for incorporating priority classes and collision avoidance. Those schemes proposed in the literature have been classified into several categories, on the basis of objectives and methods. Those are Priority Queueing Approach, Reservation-based Priority, Conflict-Free Approach, Node Partitioning Approach, Parametric and Separate Token Cycle Approach, Collision Avoidance Switch Approach, Hyperchannel Interface Access Approach, and Timer Controlled Random Access Approach.

In order to evaluate the performance of the CEBus protocol, a new theoretical analysis has been proposed. For compromising the primary channel access protocol of the CEBus, a mathematical model named Priority Channel Assigned Multiple Access with Embedded Priority Resolution (PAMA/PR) has been developed. In summary, the PAMA/PR methodology of this thesis employs (a) priority channel assignment with three priority classes for partitioning a channel access on the network, (b) embedded priority reservation at the EOP (End of Packet), (c) persistent channel access within each priority class, (d) minimum waiting time, and (e) round-robin scheme for fairness of access within the same priority class.

The exact numerical analysis of PAMA/PR has been found to be mathematically complex. The complexity has stemmed primarily from the fact that packet departure times dependent on their priorities, i.e., the lower priority must defer to the higher one. In addition, the assignment of queueing state, i.e., unqueued or queued state of a station, makes the analysis more difficult. However, the queueing state of a station for each priority as well as contention resolution during the preamble bits, do not present much difficulty in the simulation experiments. The simulation results have shown slightly improved performance over the mathematical model of the CEBus protocol at heavy loads.

Through the analysis, it has been observed that the priority functions have behaved well in handling message priorities. In light load all of the priority message delays have remained bounded and have shown similar distributions. However, in heavy load, the HIGH priority message delay continues to stay low and bounded while the DEFERRED shows a drastic increase in delay and STANDARD shows only mild delay rise.

Related to the theoretical model, an important issue is the sensitivity of the persistent model to the value of  $P$  or  $\nu_p$ . It was found that in general the channel throughput and delay are fairly insensitive to changes in  $P$  falling in the range 0.2 –

0.7 for light or moderate loads. However, in very heavy loads, a small value of  $P$  or an adaptive algorithm may be required.

In the analysis the number of packets accumulated at the end of a transmission period is simply the number of arrivals during that transmission period. In other words, the packets which were already buffered at the beginning of the transmission period are discarded. Instead, in the simulation experiments all the accumulated packets may be kept in the buffer until they are successfully transmitted. Thus the number of packets accumulated during a transmission period would depend on the packets already buffered at the beginning of the transmission period. In order to investigate the difference in delay time, packet delay and message delay have been investigated by the CEBus simulation experiments. Overall, the analytical results obtained by this method were validated by the simulation experiments closely.

In order to investigate a behavior of the network in which a router can handle three priority classes when router traffic is present between the PL and the TP, a simulation has been carried out in terms of message and packet delays, and message and channel throughputs. The inter-network traffic has showed larger delay than intra-network traffic. Thus in light loads the inter-network message delay was measured at about 100 *ms* while the intra-network traffic for the same network showed much smaller delay, approximately 30 *ms* to 40 *ms*. Thanks to the lower priority message's deference to higher priority ones, the HIGH priority message for inter-network traffic showed acceptable performance up to approximately 0.95 of offered load, keeping the delay under 500 *ms*. At offered load values larger than 55% of the channel capacity, the DEFERRED priority message for the inter-network traffic effectively cuts out.

In the near future, an ISDN-based home information system may support the intelligent home with such services as remote home control, multimedia services including a variety of audio, data, and video services, security monitoring, and energy management. A CEBus gateway could play a key role in the successful connection of



ISDN to the home.

A gateway connecting the CEBus to ISDN has been designed. A simulation study has been carried out using the gateway between the CEBus and the ISDN. The gateway is used to convert CEBus signals to ISDN ones and vice versa and to provide 16 Kb/s for the ISDN network and 10 K ONE bit/s for the home CEBus network. It has been shown that delays of inter-network traffics for any priority level are much higher than those of intra-network traffic due to waiting time in the buffers of the gateway and the two different data rates supported. On the whole, the delay from the ISDN to the CEBus direction was smaller than that from the CEBus to the ISDN in light traffic load. In heavy traffic load, larger than 70% of the network capacity, message delay from ISDN to the CEBus was longer than in the reverse direction. We have also studied the network performance sensitivity to propagation delay, i.e., the distance between the telephone office in which ISDN system is installed and the house in which a gateway and CEBus are installed. It was found that the system utilization or channel throughput deteriorated with propagation delay. This was especially true for message throughput for inter-network traffic for all priorities.

It was concluded, therefore, that a residence which is far away (high propagation delay) from the office providing the ISDN services, i.e., the telephone office, may require an acknowledgement from repeaters instead of end-terminal acknowledgement, different frequency bandwidth for transmission and reception, or hybrid circuits on the gateway and the outgoing stage of the ISDN, respectively. Under ideal conditions, i.e., zero propagation delay, proper packet length such as 300 to 500 bits approximately, and light intra- and inter- network traffic less than 70% of the offered load, the simulation showed that the CEBus system when connected to the ISDN behaves well without deteriorating the system performance.

The overall goals of the CEBus are to control home appliances intelligently using the existing house power line as the main physical medium. The CEBus not only

supports an ergonomic and aesthetic working environment which increases productivity, and provides maximum degree of safety, theater-like home entertainment, and rigorous energy control and management, but also offers a wide range of services and conveniences based on recent advances in the VLSI, computer, and telecommunication and network technologies.

## 6.2 Suggestions for Further Study

During the course of this dissertation work, it has been found that several problems require further study. They are listed below.

- (1) In developing an exact theoretical analysis, it was found difficult to evaluate the effect that several parameters have on the system's performance. The proposed PAMA/PR (Priority Channel Assigned Multiple Access with Priority Resolution) protocol employs demand priority channel access, minimum wait time, persistent start of transmission to redress collisions, and to provide contention resolution based on three priorities. However, in order to incorporate all the features of the CEBus, i.e., random start delay within 4 USTs instead of persistent procedure, contention resolution during the preamble field of 8 bits, and queueing state, i.e., unqueued or queued state of a station, further work is needed in the development of the mathematical expression.
- (2) The message delay which includes the number of packets accumulated at the end of a transmission period, in other words, the packets which were already buffered at the beginning of the transmission period, could be measured, using a new mathematical formulation. Also, the difference in delay time for packet and message delay may also be calculated by this model.
- (3) The arrival traffic is characterized by the Bernoulli process, and the geometric

distribution. Instead of these patterns, a Poisson arrival rate and exponential distribution may be utilized for numerical analysis.

- (4) The exact analysis for the CSMA/CDCR of the CEBus is complex in the mathematical development. Thus, an approximate analysis may be developed and utilized..
- (5) In this PAMA/PR, an *Unacknowledgment* mechanism is utilized. However, an *Immediate Acknowledgment* scheme may enable the transmitting station to determine the success or failure of its message across a single medium. Therefore, the Immediate Acknowledgment mechanism could be incorporated in the mathematical model or simulation.
- (6) In this dissertation, all traffic patterns are assumed to be symmetric case. This assumption contends that all nodes and three priority groups will have an opportunity to transmit packets with same probability or rate in order to allow for consistent comparisons in the study of the priority mechanism. Furthermore, the traffic may be configured in an asymmetric or unbalanced traffic pattern based on a realistic scenario.
- (7) In the simulation experiment, the effect of the number of nodes either overall or for specific priority groups could be investigated in terms of throughput and delay performance.

**PLEASE NOTE:**

**Page(s) missing in number only; text follows.  
Filmed as received.**

**U·M·I**

# BIBLIOGRAPHY

- [1] The Electronic Industries Association's "*Home Automation Standard.*"  
December 1989.
- [2] EIA-XXX. 1 CEBus Introduction and EIA-XXX. 3 Physical Layer and Media Specifications, *Draft CEBus Introduction and Draft Specification*, Oct.-Nov., 1990.
- [3] CEBus MAC-Layer Specification, Draft Proposal, July 11, 1988.
- [4] Draft CEBus PL Specification: Vol. 1 thru 3, Revised Version, EIA, Oct. 21, 1991.
- [5] Node Protocol Draft Standards: Vol. 4 Revised Version, EIA, Nov. 15, 1991.
- [6] The CEBus Brouter Protocol Draft Standards: Vol. 6 Revised Version, EIA, Jan. 15, 1992.
- [7] Hanover, G. "Networking the Intelligent Home." *IEEE Spectrum*, October 1989, pp. 48-49.
- [8] Davidson, K. "CEBus: A New Standard in Home Automation." *CIRCUIT CELLAR INK*, Aug./Sept. 1989, pp. 40-52.
- [9] Bertan, B. R. "Simulation of MAC Layer Queueing and Priority Strategies of CEBUS." *IEEE Transaction on Consumer Electronics*, Vol. 35, No. 3, August 1989, pp. 557-563.
- [10] Pakkam, S. R., and C. N. Manikopoulos. "Performance Evaluation of the Consumer Electronic Bus." *IEEE Transaction on Consumer Electronics*, Vol. 36, No. 4, Nov. 1990, pp. 949-953.
- [11] Yang, J., and C. N. Manikopoulos. "Router Connected Physical Media in Networking the Intelligent Home." *IEEE Transaction on Consumer Electronics*, Vol. 38, No. 1, Feb. 1992, pp. 30-36.

- [12] Yang, J., and C. N. Manikopoulos. "Investigation of the Performance of a Controlled Router for the CEBus." *IEEE Transaction on Consumer Electronics*, Vol. 38, No. 4, Nov. 1992, pp.
- [13] Yang, J., and C. N. Manikopoulos. "The Consumer Electronics Bus Interconnected by a Controlled Router." *The Twenty-Third Annual Pittsburgh Conference on Modeling and Simulation*, April 30 - May 1, 1992.
- [14] Markwalter, B.E., S. K. Fitzpatrick, P. J. Hargaden, and S. C. Appling. "CEBus Router Testing." *IEEE Transactions on Consumer Electronics*, Vol. 37, No. 4, Nov. 1991, pp. 823-828.
- [15] Yang, J., and C. N. Manikopoulos. "Determination of the Optimum Packet Length and Buffer Sizes for the Consumer Electronics Bus." *IEEE Transaction on Consumer Electronics*, Vol. 38, No. 4, Nov. 1992.
- [16] Yang, J., and C. N. Manikopoulos. "Optimum Packet Length and Buffer Sizes of the Consumer Electronics Bus." *The Twenty-Third Annual Pittsburgh Conference on Modeling and Simulation*, April 30 - May 1, 1992.
- [17] Markov, A. "Extension of the Limit Theorems of Probability Theory to a Sum of Variables Connected in a Chain." *The Notes of the Imperial Academy of Sciences of St. Petersburg VIII Series*, Physio-Mathematical College, Vol. XXII, No. 9, Dec. 1907.
- [18] Kleinrock, Leonard. *Queueing Systems*, Vol. 1; Theory, wiley-Interscience Publication, John Wiley & Sons Inc., New York, March 1974.
- [19] Keiser, Gerd E. *Local Area Networks*, McGraw-Hill Inc., 1989.
- [20] Neuts, Marcel F. *Matrix Geometric Solutions in Stochastic Models: An Algorithmic Approach*, The Johns Hopkin University Press, Baltimore and London, 1981.
- [21] Gold, Y. I., and W. R. Franta. "An Efficient Collision-Free Protocol for Prioritized Access-Control of Cable or Radio Channels." *Computer Networks*, July 1983, pp. 83-93.
- [22] Hansen, L. W., and M. Schwartz. "An Assigned-slot Listen-before-transmission Protocol for a Multiaccess Data Channel." *IEEE Trans. Comm.*, vol. COM-27, June 1979, pp. 846-857.

- [23] Tobagi, F. A. "Analysis of Two Hop Centralized Packet Radio Network: Part-I Slotted ALOHA." *IEEE Trans. Comm.*, vol. COM-28, Feb. 1980, pp. 196-207.
- [24] Kleinrock, L., and F. A. Tobagi. "Packet Switching in Radio Channels: Part I-Carrier Sense Multiple Access Models and Their Throughput Delay Characteristics." *IEEE Trans. Comm.*, COM-23, Dec. 1975, pp. 1400-1416.
- [25] Kleinrock, L., and S. S. Lam. "Packet Switching in a Multiaccess Broadcast Channel: Performance Evaluation." *IEEE Trans. Comm.*, vol. COM-23, April 1975, pp. 410-423.
- [26] Lam, S. S., and L. Kleinrock. "Packet Switching in a Multiaccess Broadcast Channel: Dynamic Control Procedures." *IEEE Trans. Comm.*, vol. COM-23, Sept. 1975, pp. 891-904.
- [27] Ferguson, M. J. "On the Control, Stability, and Waiting Time in a Slotted ALOHA Random-Access System ." *IEEE Trans. Comm.*, Nov. 1975, pp. 1306-1311.
- [28] Takagi, Hideaki, and Leonard Kleinrock. "Throughput Analysis for Persistent CSMA Systems." *IEEE Trans. Comm.*, Vol. COM-3, July, 1985, pp. 627-638.
- [29] Takagi, H., and L. Kleinrock. "Correction to Throughput Analysis for Persistent CSMA Systems." *IEEE Trans. Comm.*, COM-35, Feb. 1987, pp. 243-245.
- [30] Kiesel, W. M., and P. J. Kuehn. "CSMA-CD-DR: A New Multi-Access Protocol for Distributed Systems." *Proceedings of NTC* ch 1679, A 2.4.1-A 2.4.6, Dec. 1981.
- [31] Kamal, A. E. "CSMA/CD with Two Persistence Factors: A Unified Performance Model for CSMA/CD." *IEEE*, ch 2702, Sept. 1989, pp. 152-160.
- [32] Karvelas, D. "Performance Analysis of Timer Based Medium Access Schemes in Symmetric Token Passing Networks." Ph.D. dissertation, Dept. of EE, University of Toronto, March 1990.
- [33] Lam, S. S. "A Carrier Sense Multiple Access Protocol for Local Networks." *Comput. Networks*, vol. 4, Feb. 1980, pp. 21-32.
- [34] Tobagi, F. A. "Analysis of a Two Hop Centralized Packet Radio Network: Part II-Carrier Sense Multiple Access." *IEEE Trans. Comm.*, vol. COM-28, Feb. 1980, pp. 208-216.

- [35] Tobagi, F. A. "Distributions of Packet Delay and Inter-departure Time in Slotted ALOHA and Carrier Sense Multiple Access." *Jour. ACM*, vol. 29, No. 4, Oct. 1982, pp. 907-927.
- [36] Matsumoto, Y., Y. Takahashi, and T. Hasegawa. "Analsis of Interdeparture Time and Response Time in Asynchronous CSMA/CD- DFT System." *IEEE GLOBECOM*, Tokyo, Japan, 1987, pp. 582-587.
- [37] Tobagi, F. A., and M. Fine. "Performance of Unidirectional Broadcast Local Area Networks: Expressnet and Fasnet." *IEEE J. Sel. Areas Comm.*, Vol. SAC-1, No. 5, Nov. 1983, pp. 913-926.
- [38] Tobagi, F. A. "Multiaccess Protocols in Packet Communication System." *IEEE Trans. Comm.*, vol. COM-28, April 1980, pp. 468-488.
- [39] Ross, M. J., and O. A. Mowafi. "Performance Analysis of Hybrid Switching Concepts for Integrated Voice/data Communications." *IEEE Trans. Comm.*, vol COM-30, No. 5, May 1982, pp. 1073-1087.
- [40] Gopal, P. M., and J. W. Wong. "Hybrid Token-CSMA/CD protocol." *Computer Networks and ISDN Systems*, 9 , 1985, pp. 131-141.
- [41] Tobagi, F. A., F. Borgonovo and L. Fratta. "Expressnet: A High Performance Integrated Services Local Area Network." *IEEE J. Sel. Areas Comm.*, vol. SAC-1, No. 5, Nov. 1983, pp. 898-913.
- [42] Fouad A. Tobagi, Flaminio Borgonovo and Luigi Fratta, "Expressnet:A High Performance Integrated-Service Local Area Network." in *Advances in Local Area Networks*, the IEEE Press, 1987.
- [43] Nutt, G. J., and D. L. Bayer. "Performance of CSMA/CD Networks under Combined Voice and Data Loads." *IEEE Trans. Comm.*, Vol. COM-30, Jan. 1982, pp. 6-11.
- [44] Takagi, H., and M. Murata. "Output Processes of Persistent CSMA and CSMA/CD." *Computer Networks and ISDN Systems*, vol. 13, 1987, pp. 333 - 347.
- [45] Tobagi, F. A., and V. B. Hunt. "Performance Analysis of Carrier Sense Multiple Access with Collision Detection." *Proceeding of the LACN symposium*, May,



- 1979, pp. 217-245.
- a. *Computer Networks*, April. 1980, pp. 245-249.
- [46] F. A. Tobagi and L. Kleinrock, "Packet Switching in Radio Channels: Part IV- Stability Considerations and Dynamic Control in Carrier Sense Multiple Access." *IEEE Trans. Comm.*, COM-25, No. 10, Oct. 1977, pp. 1103-1120.
- [47] Meditch, J. S., and C. A. Lea. "Stability and Optimization of the CSMA and CSMA/CD Channels." *IEEE Trans. Comm.*, COM-25, June 1983, pp. 763-774.
- [48] Bertsekas, D., and R. Gallager. *DATA NETWORKS*, Prentice-Hall, Inc., Englewood Cliffs, New Jersey 1988.
- [49] Tanenbaum, A. *Computer Networks*, Prentice-Hall, Inc., Englewood Cliffs, New Jersey 1988.
- [50] Schwartz, M. *Telecommunication Network: Protocols, Modeling and Analysis*, Addison-Wesley, 1987.
- [51] Jaiswal, N. K. *Priority Queues*, Academic Press, New York, 1968.
- [52] Choudhury, G. L., and S. S. Rappaport. "Priority Access Schemes Using CSMA-CD." *IEEE Trans. Comm.*, Vol. Com-33, No.7, July 1985.
- [53] Cidon, I., and M. Sidi. "Recursive Computation of Steady Probabilities in Priority Queues." *IEEE*, Ch2702, Sept. 1989.
- [54] Marks, B. I. "State Probabilities of M/M/1 Priority Queues." *OPNS. Res.* 21, 1973, pp. 974-987.
- [55] Molle, M.L., and L. Kleinrock. "Prioritized-Virtual-Time CSMA: Head-of-the-Line Priority Classes without Channel Overhead." *Proc. Int. Comm. Conf.*, 1985, pp. 1113-1118.
- [56] Iida, I., M. Ishizuka, Y. Yasuda and M. Onoe. "Random Access Packet Switched Local Computer Network with Priority Function." *Proc. Nat. Telecomm. Conf.*, 1980, pp. 37.4.1.-37.4.4.
- [57] Iida, I., Y. Yasuda, and Y. Komachi. "Modified CSMA/CD Local Area Network with Message-based Priority Function." *Proc. IEEE INFOCOM*, 1983, pp. 472- 477.

- [58] Choudhury, G. L. "An Investigation of Communication Media Access Schemes Using Collision Channels." Ph.D. thesis, EE Dept., *State University of New York at Stony Brook*, Aug. 1982.
- [59] Tobagi, F. A. "Carrier Sense Multiple Access with Message-Based Priority Functions." *IEEE Trans. Comm.*, vol. COM-30, No. 1, Jan. 1982, pp. 185-200.
- [60] Gonzalez-Cawley, N. "Simulation of Message-Based Priority Functions in Carrier Sense Multiaccess/Broadcast System." *Technical Report*, No. 213, Stanford University, June, 1981.
- [61] Rothaus, E. H., and D. Wild. "MLMA: A Collision-free Multi-access Method." in *Proc. IFIP Congress 77*, Amsterdam, The Netherlands: North-Holland, 1977, pp. 431-436.
- [62] Mark, J. W. "Global Scheduling Approach to Conflict-free Multiaccess via a Data Bus." *IEEE Trans. on Comm.*, Vol. COM-26, 1978, pp. 1342-1352.
- [63] Taub, D. M. "Contention-resolving Circuits for Computer Interrupt Systems." in *Proc. Inst. Elec Eng.*, Vol. 123, 1976, pp. 845-850.
- [64] Tabagi H., and L. Kleinrock. "Output Processes in Contention Packet Broadcasting Systems." *IEEE Trans. Comm.*, vol. COM-33, No. 11, Nov. 1985, pp. 1191 - 1199.
- [65] Arora, R., and A. Albicki. "Prioritized Access in CSMA Networks: A Node Partitioning Approach." *IEEE Trans. Comm.* 1988, pp. 275-280.
- [66] Mark, J. W. "Distributed Scheduling Conflict-free Multiple Access for Local Area Communication Network." *IEEE Trans. Comm.*, COM-28, pp. 1968-1976 Dec. 1980, pp. 1968-1976.
- [67] Kleinrock, L., and M. Scholl. "Packet Switching in Radio Channels: New Conflict-free Multiple Access Schemes for a Small Number of Data User." *ICC Conf. Proc.*, Chicago, June, 1977, pp. 22.1.105-22.1.111.
- [68] Onunga, John O. "Performance Analysis of CSMA with Priority Acknowledgments (CSMA/PA) on Noisy Data Networks with Finite User Population." - *IEEE Trans. on Comm.*, Vol.39, No. 7, July, 1991.

- [69] Franta, W. R., and M. Bilodeau. "Analysis of a Prioritized CSMA Protocol based on Staggered Delays." *Acta Inform.*, Vol. 13, No. 4, 1980, pp. 299-324.
- [70] Shem, S. H., and H. T. Liu. "Dynamic CSMA/CD with a Priority Scheme." *Proc. IEEE INFOCOM*, 1986, pp. 258-263.
- [71] Albanese, A. "Star Network with Collision Avoidance Circuits." *Bell System Technical Journal*, Vol. 62, No. 3, March, 1983,
- [72] Lee, E. S., and P. I. P. Boulton. "The Principles and Performance of Hubnet: A 50 Mbit/s Glass Fiber Local Area Network." *IEEE Journal on Selected Area in Communications*, Vol. SAC-1, No. 5, Nov. 1983, pp. 711-720.
- [73] Suda, T., Y. Yemini, and M. Schwartz. "Tree Network with Collision Avoidance Switches." *Proc. of INFOCOM*, 1984, pp. 105-113.
- [74] Suda, T., S. Morris, and T. Nguyen. "Tree LANs with Collision Avoidance: Protocol, Switch Architecture and Simulated Performance." *Computer Networks and ISDN Systems*. 1984.
- [75] Yemini, Y. "Tinkernet: or Is There Life Between LANs PBX, ?" *ICC* 1983.
- [76] Suda, T., and K. Goto. "Performance Study of a Tree LAN with Collision Avoidance." *IEEE Trans. Comm.*, Sept. 1989, pp. 59-68.
- [77] Prasad, K., and R. Patel. "Performance Analysis of Ethernet Based on an Event Driven Simulation Algorithm." *IEEE Computer Networks and ISDN Systems*, 1988, pp. 253-262.
- [78] Rom, R., and F. A. Tobagi. "Message-Based Priority Function in Local Multiaccess Communication System." *Computer Networks*, North-Holland, 1981, pp. 273- 286.
- [79] Chlamtac, I., and W. R. Franta. "Message-based Priority Access to Local Networks." *IPC Business Press*, Vol. 3, No. 2, April, 1980.
- [80] Stallings, W. "Local Networks." *Computing Surveys*, March 1984, pp. 3-41.
- [81] Burr, W. "An Overview of the Proposed American National Standard for Local Distributed Data Interfaces." *Commun. ACM*, 26,, Oct. 1983, pp. 554-561.

- [82] Chang, J-F., and T-H. Yang. "The Effect of Prioritization on the Behavior of a Finite Queue with Batch Poisson Inputs and a Synchronous Server." *Computer Networks and ISDN Systems*, 1991, pp. 1-16.
- [83] Gburzynski, P., and P. Rudnicki. *The LANSF Protocol Modeling Environment*. Department of Computing Science, The University of Alberta, Edmonton, Alberta, Canada, 1989.
- [84] Murata, M., and H. Takagi. "Mean Waiting Times in Nonpreemptive Priority M/G/1 Queues with Server Switchover Times." *Teletraffic Analysis and Computer Performance Evaluation*, Vol. 7, North-Holland studies in Telecommunication, Elsevier Science Publishing Company, Inc., 1987, pp. 395-407.
- [85] Spragins, J. D., J. L. Hammond, and K. Pawlikowski. *Telecommunications: Protocols and Design*, Addison-Wesley Publishing Company, 1991.
- [86] Stallings, William. ed., *Tutorial: Integrated Services Digital Networks*, IEEE Computer Society Press, Washington, D.C., 1985.
- [87] IEEE Journal on Selected Areas in Communications, Special Issue on "Integrated Services Digital Network: Technology and Implementations II." *IEEE Computer Society*, New York, November 1986.
- [88] Freeman, R. L. "Telecommunication System Engineering." 2nd Edition, *A Wiley-Interscience Publication*, New York, John Wiley & Sons Inc, 1989.
- [89] *Data Communication Networks: Transmission, Signalling and Switching, Network Aspects, Maintenance and Administration Arrangements*, Vol. VIII. 4, CCITT Recs. X.40-X.181, VIII plenary Assembly, Malaga-Torremolinos, 1984.
- [90] Mark, J. W. "Distributed Scheduling Conflict-free Multiple Access for Local Area Communication Networks." *IEEE Trans. on Comm.*, Vol. COM-28, Dec. 1980, pp. 1968-1976.
- [91] "Carrier Sense Multiple Access with Collision Detection (CSMA/CD)." *ANSI/IEEE Std. 802.3*, 1985.
- [92] *IEEE Communications Magazine*, A special Issue on Network Architectures for ISDN, Vol. 24, No. 3, March 1986.

- [93] *Fiber to the Home (FTTH): A Compilation of Results from Recent Bellcore Studies*, Bellcore Special Report, SR-TSY-001309, April 1989.
- [94] Lin, T. P. "Migration of Home Information System Toward ISDN." *IEEE Trans. on Consumer Electronics*, Vol. 36, No. 2, May 1990, pp. 103-109.
- [95] "Specifications of Signalling System No.7." *CCITT Recommendations Q-Series*, 1989.
- [96] Lin, T. P. "ISDN Basic Rate Interface Architecture For ADPCM Transmission." *Computer Networks and ISDN systems*, Vol. 18, No. 1, November 1989, pp. 55-64.
- [97] Lin, T. P. "Switch Access Architecture For Quad Voice Lines with Data On-Demand per ISDN BRI." *proceedings IEEE INFOCOM'89 Ottawa*, April 1989, pp. 647-654.
- [98] Helgert, H. J. *Intrgrated Services Digital Networks; Architectures, Protocols, Standards*, Reading, Massachusetts, Addison-Wesley Publishing Company, 1991.
- [99] Zhang, X. U., and R. H. Deng. "Gateway Design for LAN Interconnection via ISDN." *Computer Networks and ISDN systems*, Vol. 19, No. 1, 1990, pp. 43-51.
- [100] Son, S. H., and C. K. Un. "Performance Analysis of an Integrated Voice/Data Packet Communication Network with Window Flow Control." *Interconnection via ISDN.* *Journal of Korea Inst. of Commun. Sci.*, Vl. 11 , No. 4, August 1990, pp. 227-240.
- [101] Lee, G. Y., and C. K. Un. "Delay Analysis of the ISDN D-channel Access Protocol." *Computer Networks and ISDN systems*, Vol. 19, No. 1, 1990, pp. 25-36.
- [102] "Intelligent Buildings: Reality or Illusion ?" *IEEE Communications Magazine*, Vol. 29, No. 4, April 1991.
- [103] Yang, J-S. "Design of Topology and Analysis of Network in Computer Network." Master's Program in Electronic Engineering, Graduate School of Kon-Kuk University, July 1985.

- [104] Zimmerman, H. "OSI Reference Model - the ISO Model of Architecture for Open Systems Interconnection." *IEEE Trans. on Comm.*, April 1982, pp. 425- 432.
- [105] ISO/TC97/SC16/WG6, "Transport Protocol Specification (CN1169)." *Computer Communication Review*, Oct. 1982.
- [106] Groenbaek, I. "Conversion Between the TCP and ISO Transport Protocols as a Method of Achieving Interoperability between Data Communications Systems." *IEEE J. Selected Area Comm.* Vol. SAC-4, No.2, March 1986, pp. 288-296.
- [107] CCITT, "Recommendation X.75-Terminal and Transit Call Control Procedures and Data Transfer System on International Circuits between Packet-switched Data Networks." Study Group VII, *Int. Telecommunications Union*, Geneva, Switzerland, April, 1978.