

Copyright Warning & Restrictions

The copyright law of the United States (Title 17, United States Code) governs the making of photocopies or other reproductions of copyrighted material.

Under certain conditions specified in the law, libraries and archives are authorized to furnish a photocopy or other reproduction. One of these specified conditions is that the photocopy or reproduction is not to be “used for any purpose other than private study, scholarship, or research.” If a user makes a request for, or later uses, a photocopy or reproduction for purposes in excess of “fair use” that user may be liable for copyright infringement,

This institution reserves the right to refuse to accept a copying order if, in its judgment, fulfillment of the order would involve violation of copyright law.

Please Note: The author retains the copyright while the New Jersey Institute of Technology reserves the right to distribute this thesis or dissertation

Printing note: If you do not wish to print this page, then select “Pages from: first page # to: last page #” on the print dialog screen

The Van Houten library has removed some of the personal information and all signatures from the approval page and biographical sketches of theses and dissertations in order to protect the identity of NJIT graduates and faculty.

ABSTRACT

Title of Thesis: Recycling: Separation Process of Major Thermoplastics from Postconsumer Plastics stream.

Rafael Rodriguez, Master of Engineering Science, 1990

Thesis directed by: Deran Hanesian, PhD

The complete process for separating Low Density Polyethylene (LDPE), High Density Polyethylene (HDPE), Polyvinyl Chloride (PVC), Polypropylene (PP), Polystyrene (PS), Polyurethane (PU), and Polyethylene Terephthalate (PET) from a mixture of postconsumer plastics materials was presented. The driving forces considered to achieve separation were different densities and selective solubility of plastics in specific solvents.

The proposed process separates Polyurethane and Polystyrene by using aqueous solutions of different densities. On the other hand, the other five plastics are separated using solvents.

Diagrams showing streams and plastics separation in each unit were discussed. Individual material balances for each step were performed for a total feed stream of 50,000,000 pounds per year of the different plastics mixture.

The complete material balance for the entire process was programmed using QUATTRO PRO, which allows fast calculation of the streams when changes in data are introduced.

RECYCLING:
SEPARATION PROCESS OF MAJOR
THERMOPLASTICS FROM POSTCONSUMER PLASTICS STREAM

by
Rafael A. Rodriguez

Thesis submitted to the Faculty of the Graduate
School of the New Jersey Institute of Technology in partial
fulfillment of the requirements for the degree of
Master of Science in Chemical Engineering
1990

APPROVAL SHEET

Title of Thesis : RECYCLING : SEPARATION PROCESS OF MAJOR
THERMOPLASTICS FROM POSTCONSUMER PLASTICS
STREAM

Name of Candidate : Rafael A. Rodriguez
Master of Engineering Science, 1990

Thesis and Abstract Approved : _____
Deran Hanesian
Professor
Chemical Engineering

9/10/90
Date

Signatures of other members
of the thesis committee

9/10/90
Date

VITA SHEET

Name: Rafael Arturo Rodriguez.

Permanent address:

Degree and date to be conferred: Master Eng. Sc., 1990

Date of Birth:

Place of Birth:

Secondary Education: Jose Dubeau High School, 1974.

Collegiate institutions attended	Dates	Degree	Date
Universidad Autonoma de Santo Domingo.....	1974-81	B.S. in Chem.Eng	1981
New Jersey Institute of Technology.....	1989-90	MS	1990

Major: Chemical Engineering

Publications: Thesis to be published

Position held: Production Manager, Industria Nortena del Caucho, Republica Dominicana.

DEDICATION

To Mayra, Carolina, and Arturo.

ACKNOWLEDGMENT

The author wishes to express his sincere gratitude to Dr. Deran Hanesian, for his advice and guidance as the thesis adviser.

TABLE OF CONTENTS

Chapter	Page
I. BACKGROUND	1
1. PLASTICS AND SOLID WASTE	1
2. REASONS FOR RECYCLING	4
3. TYPES OF RECYCLING	4
4. THERMOPLASTICS AND THERMOSETS	6
5. SEVEN MAJOR PLASTICS	7
6. PROPERTIES OF SEVEN MAJOR PLASTICS	12
7. SOLUBILITY OF POLYMERS	20
8. METHODS FOR EVALUATING SOLUBILITY PLASTICS-SOLVENT	24
9. CHOOSING A SOLVENT	33
II. PROCESS DESCRIPTION	36
III. DISCUSSION OF CALCULATIONS	47
CONCLUSIONS	79
RECOMMENDATIONS	80
APPENDIX 1. Results of material balance using QUATTRO PRO	82
APPENDIX 2. Technical information about the solvent Dimethylformamide (DMF)	122
REFERENCES	125

LIST OF TABLES

Table	Page
I. Approximate Composition of Municipal Solid Waste (MSW)	2
II. Estimated Elimination of Solid Waste (%)	3
III. Properties of High Density Polyethylene	13
IV. Properties of Low Density Polyethylene	14
V. Properties of Polyvinyl Chloride	15
VI. Properties of Polypropylene	16
VII. Properties of Polystyrene	17
VIII. Properties of Polyurethane	18
IX. Properties of Polyethylene Terephthalate	19
X. Aproximate Solubility Parameters Values for Several Plastics	24
XI. Solubility Parameters Values for Solvents	25
XII. Solubility Parameters for Some Solvents	31
XIII. Density Ranges of Virgin Plastics	43
XIV. U.S. Plastics Sales 1989	47
XV. Seven Major Thermoplastics Types	49
XVI. Seven major plastics in pounds/yr based on 50,000,000 pounds/yr of mixed plastics entering to the process	50
XVII. Composition of stream 3 in lb/yr and lb/hr	54

(continuation)

Table	Page
XVIII. Material Balance Polyvinyl Chloride (PVC), Polyethylene Terephthalate (PET), and High Density Polyethylene (HDPE) bottles Separation	57
XIX. Material Balance in Air Cyclones unit	59
XX. Material Balance Paper and EVA Separation	61
XXI. Material Balance for the Separation of Plastics Denser than Water and Less Dense than Water ...	64
XXII. Material Balance Polystyrene (PS) Separation ..	67
XXIII. Material Balance Polyurethane (PU) Separation..	71
XXIV. Material Balance Polyvinyl Chloride (PVC) and Polyethylene Terephthalate (PET) Separation ...	74
XXV. Material Balance Low Density Polyethylene (LDPE), High Density Polyethylene (HDPE) and Polypropylene (PP) Separation.....	78

LIST OF FIGURES

Figure	Page
1. Solubility Map	29
2. Hansen's Three-dimensional Solubility Parameter Plot	32
3. Proposed Flow Diagram	38
4. Composition of a 2-Liter PET Beverage Bottle ..	51
5. Waste Material Separation	53
6. Separation of Polyvinyl Chloride (PVC) bottles, High Density Polyethylene (HDPE) bottles, and Polyethylene Terephthalate (PET) bottles	55
7. Partial Separation of Paper	58
8. Separation of Residual Paper and Ethylene Vinyl Acetate (EVA)	60
9. Separation of Plastics Denser than Water from Those Lighter than Water	63
10. Separation of Polystyrene (PS)	66
11. Separation of Polyurethane (PU)	70
12. Separation of Polyvinyl Chloride (PVC) and Polyethylene Terephthalate (PET)	74
13. Separation of Low Density Polyethylene (LDPE), High Density Polyethylene (HDPE) and Polypropylene (PP)	77

CHAPTER I

B A C K G R O U N D

1. PLASTICS AND SOLID WASTE

The process of plastics recycling started in the early 1970's when people were worried about the ecological implications that the solid waste represented (37). Several years ago, plastics recycling began to increase rapidly, not only because it contributes to reduce the volume of waste material which has to be eliminated, but also because reuse of recycled plastics represents an important economic factor for recyclers.

The U.S. produces about 320 billion pounds of post consumer waste every year. Plastics represent up to 30% of the total volume (36). The Environmental Protection Agency pointed out that by the year 2000 the solid waste will increase to 380 billion pounds, representing a serious elimination problem due to the small amount of land available to store this considerable volume of material (36).

An approximate composition of this municipal solid waste (MSW) is shown in Table I.

Table I. Approximate Composition of MSW (26).

Weight, percent	
MATERIAL	PERCENTAGE
paper	42
yard waste	16
glass	9
steel	8
plastics	7
aluminum	1
others	17

total	100

Although plastics materials only represent about 7% by weight, they are very important from an economic point of view.

The amount of plastic waste from postconsumers is estimated to grow from 35 billion pounds in 1990 to about 43 billion pounds in 1995 (4). This represents an increase of 22%.

Among the alternatives to reduce landfilling, recycling offers a group of advantages and benefits. By recycling post consumer plastics, new products can be introduced into the market at lower cost. In addition, once plastics are

collected by citizens to be reprocessed, the volume of the municipal solid waste is reduced . As a consequence, less land is used to dispose of the waste materials. Elimination of the solid waste is carried out essentially by four different forms: source reduction, recycling, incineration, and landfill. Source reduction is the decrease in waste by concerned citizens using less material and packaging producers improving the design of packaging. MSW is reduced when producers design appropriate sizes of packaging to be used in stores, supermarkets, and other commercial places. In this way for a small product a small package will be used instead of a large one. Consumers in a supermarket, for example, should not use more bags than they need to carry their goods. In Europe, people use their own packaging when they go shopping as a way of reducing waste.

An estimation of the percentage of recycling, incineration and landfill for the next five years appears in Table II.

Table II. Estimated Elimination of Solid Waste (%) (25)

TYPE	1990	1995
Recycling	10	25
Incineration	10	20
Landfill	80	55

Information from Table II shows an increase of 15% in the recycling operation by 1995, higher than the values estimated for incineration. Furthermore, the method of landfill will be reduced from 80% to 55%.

In New Jersey, the objective is also toward reducing landfill from 85% to 10% and increasing recycle from 10% to 25% by 1995 (26).

2. REASONS FOR RECYCLING

Different factors have contributed to recycling of postconsumer plastics materials. The fact that goods from recycled plastics are durable and that they are widely used in different forms, indicates an economic option for recyclers. In addition, the production of plastics in the U.S. for the last ten years shows a continuous rise, suggesting that the volume of plastics in the solid waste material has also increased in this period of time (38). More land will be necessary for landfilling in case that recycling is not developed.

3. TYPES OF RECYCLING

There are four main categories for recycling plastics depending on how the waste resin is managed. The first type of recycling is called primary, in which the noncontaminated waste material is employed to manufacture products with the

same characteristics to the original product (12). This category has applied to industrial recycling which has been in process for many years.

In secondary recycling the waste plastic is used for the manufacture of a product with different quality than the original product (4). This category is primarily applied to post consumer plastic waste.

Tertiary recycling process, such as pyrolysis and hydrolysis, use plastic material to produce fuels and chemicals.

Quaternary recycling incinerates plastics materials to use their heat content as energy which is required in other processes such as the production of electricity or heat energy.

In 1985, the Plastics Recycling Foundation was formed, establishing the Center for Plastics Recycling Research (CPRR) at Rutgers, the State University of New Jersey, at the Busch Campus, Piscataway, New Jersey. Since its formation, CPRR has conducted research and studies for plastics recycling. At present, plastics recycling is performed by many people in the U.S. and other countries. The separation of high density polyethylene (HDPE) and polyethylene terephthalate (PET) from beverage containers is carried out in many states. Others recyclers simply extruded a mixture of different plastics to produce goods

that do not require purity in terms of resin content for their final use.

4. THERMOPLASTICS AND THERMOSETS

Plastics are classified into two main types thermoplastics and thermosets. Thermoplastics are characterized for not having crosslinked bonds and are converted into products by melting, shaping, and cooling. Therefore, thermoplastics can be softened and re-shaped again by using temperature and pressure, to obtain other articles without any change of the inherent properties.

Thermosetting plastics present cross-linked molecular bonds in their structure. Once these plastics are formed, the process is irreversible because these materials can not be melted and reshaped.

Packaging materials are produced principally from thermoplastics, whereas thermosets are used widely in the transportation sector (4).

5. SEVEN MAJOR PLASTICS

The major thermoplastic materials present in the postconsumer stream are LDPE, HDPE, PVC, PP, PS, PU, and PET. These plastics have different properties which differentiate one plastic from the other. This study summarizes basic information about these plastics. A complete discussion of these 7 plastics can be found in several sources (1,3,6,9,17,18,20,21,30).

LOW DENSITY POLYETHYLENE (LDPE)

LDPE is a translucent partial crystalline polymer (50-60% of crystallinity) with a branched structure. LDPE is the product of the polymerization of pure ethylene at 150-250°C and at high pressure of 20,000-35,000 psi, in presence of oxygen or an organic peroxide:

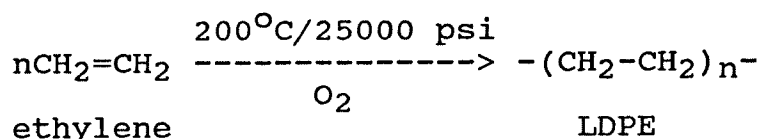

The melting point of LDPE is about 115 °C with a density between 0.91-0.928 grams per cubic centimeter. LDPE is widely used in packaging films, containers, and bottles, molded articles, electrical insulation, coatings, pipe, and others products.

HIGH DENSITY POLYETHYLENE (HDPE)

HDPE is a linear polyethylene having about 90% of crystalline structure. Similar to LDPE, it is obtained from the ethylene polymerization but at different conditions of temperature, pressure, and catalyst. Temperatures are up to 350°C and pressures between 70-600 psi.

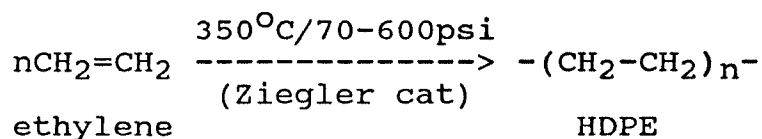

The melting point of HDPE is 135°C and its density is between 0.94-0.96 grams per cubic centimeter. The properties of HDPE are different than those of LDPE due to its higher crystallinity. HDPE has a greater strength and hardness.

Among the uses of HDPE are the manufacturing of bottles and containers by blowing molding, tubs, caps, pipe, wire cable insulation, injected articles, etc.

POLYVINYL CHLORIDE (PVC)

PVC is a low crystalline polymer due to its irregular structure. This versatile plastic exhibits excellent physical and electrical properties. It is obtained from the polymerization of vinyl chloride initiated by peroxide or azo-compounds. The following reaction shows how PVC is formed.

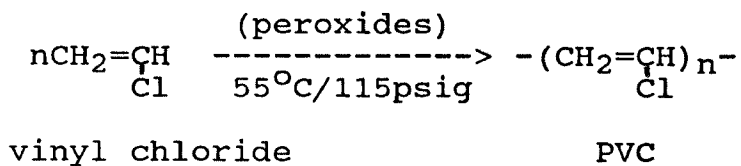

The structure and properties of the PVC obtained depend on the temperature at which the polymerization is achieved. At high temperature PVC with higher softening point is obtained. The two types of PVC, elastic and rigid are used in different products. Elastic PVC finds application in shower curtains, floor covering, raincoats, dishpans, dolls, bottles, wire insulation and films among others. Rigid PVC is used in pipes, film, sheet, blow molding, records, toys, etc.

POLYPROPYLENE (PP)

PP is formed by the reaction of propylene in the presence of a catalyst at temperature between 50-120°C.

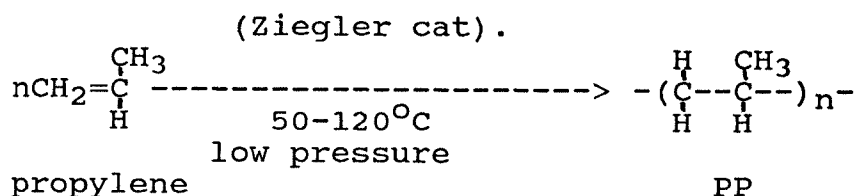

The crystalline product is mainly isotactic, with particular properties (different from both syndiotactic and atactic forms) that are very important for commercial uses.

Isotactic PP is linear and highly crystalline with a melting point of 176°C.

The density of PP is 0.90 grams per cubic centimeter, the lowest density of any commercially available thermoplastic. It is basically used in automobile and appliances parts, wire insulation, pipe protective liners, decorative items, packaging, carpeting materials, ropes, and nets.

POLYSTYRENE (PS)

PS is a linear polymer with different structures. It is produced from the polymerization of styrene in presence of free radical catalysts.

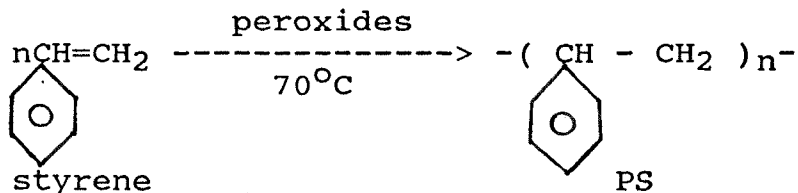

PS is hard, transparent, and melting point about 240°C. The atactic PS form is the product which is used commercially. Isotactic PS is not used commercially because it is more brittle and more difficult to process than the atactic PS.

Chemically PS is resistant to alkalis, acids, oxidizing agents yet at high temperature degradation occurs with a

characteristic odor of the monomer .

PS is used in packaging, appliances, and furniture components, toys, insulating panels, rigid foam packaging, cups, trays, knife, spon, fork, etc.

POLYURETHANE (PU)

PU is a polymer that results from the reaction of a disocyanate and a glycol.

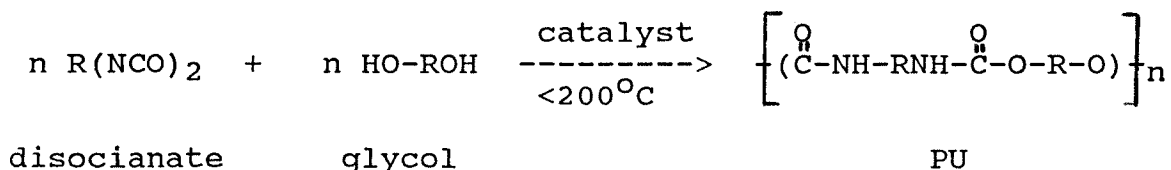

PU resins can be produced in different forms depending upon the desired form (hard, rigid, flexible, and foams). Linear PU is used in fibers and also can be extruded and injected as a common plastic material. The use of foamed PU grew more rapidly than the other forms due to the flexibility and resistance to aging and solvent. At present, statistics show that foamed PU is used more than the other forms of PU.

POLYETHYLENE TEREPHTHALATE (PET)

PET is a thermoplastic material prepared by the reaction of ethylene glycol (EG) and terephthalic acid (TPA)

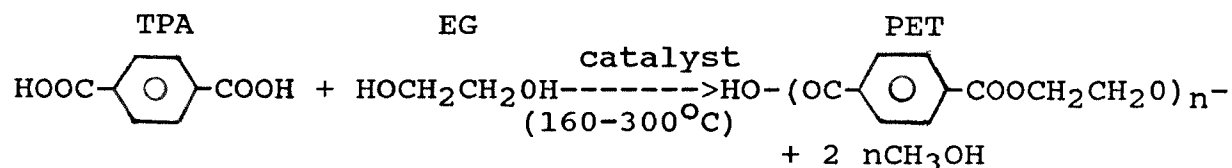

PET has a very high melting point (249°C) and represents the largest commercial polyester used in polyester fibers.

In blow molding applications, PET has a major economical use in PET beverage containers and food containers. Their products are lighter than those made of glass, steel, and aluminum. As a consequence both energy consumption and cost of transportation are lower than those for the mentioned materials during the process of delivering from one place to another.

PET containers are also used for wines, beer, syrups, among other products.

6. PROPERTIES OF SEVEN MAJOR PLASTICS

Plastics materials have physical, mechanical, electrical and chemical properties which are particular for each plastic. Tables III, IV, V, VI, VII, VIII, and IX summarize some of the most important properties for HDPE, LDPE, PVC, PP, PS, PU, and PET.

Table III. Properties of High Density Polyethylene.

Melting Point, °C	: 135
Specific Gravity	: 0.94-0.96
Specific Heat, cal/g °C	: 0.46
Thermal Conductivity, cal/cm ² ,s, °C/cm *10 ⁻⁴	: 11.0-12.4
Coefficient of Linear Expansion, in/in/°C x10 ⁻⁵	: 11.0-13.0
Elongation, %	15-100
Tensile Modulus, psi	: 102000-203000
Tensile strength, psi	: 3100-5500
Impact strength, ft lb/in, 1/2" bar	: 0.5-23
Flexural Strength, psi	: 5200
Compressive Strength, psi	: 2400
Abrasion Resistance	: POOR
Dielectric Strength, Kv/mm	: 70
Dielectric Constant @ 60 Hz	: 2.30-2.35
Water Absorption, 24 h, 1/8" thick,%	: <0.01
Chemical Stability, resistant to acids:	excellent
	bases: excellent
	sunlight: poor, crazes
Toxicity:	most grades meet FDA requirements for food use.

Sources: (2,6,11).

Table IV. Properties of Low Density Polyethylene.

Melting Point, °C	: 115
Specific Gravity	: 0.914-0.928
Specific Heat, cal/g °C	: 0.55
Thermal Conductivity, cal/cm ² ,s, °C/cm *10 ⁻⁴	: 8
Coefficient of Linear Expansion, in/in/°C x 10 ⁻⁵	: 10.0-20.0
Elongation, %	300-1000
Tensile Modulus, psi	: 20000-200000
Tensile strength, psi	: 12000-34000
Impact strength, ft lb/in, 1/2" bar	: no break
Flexural Strength, psi	: 725-3050
Compressive Strength, psi	: 3300
Abrasion Resistance	: poor
Dielectric Strength, Kv/mm	: 18-27
Dielectric Constant @ 60 Hz	: 2.25-2.35
Water Absorption, 24 h, 1/8" thick,%	: <0.01
Chemical Stability, resistant to acids:	excellent
	bases: excellent
	sunlight: poor
Toxicity:	most grades meet FDA requirements for food use.

Sources: (2,6,11).

Table V. Properties of Polyvinyl Chloride.

Melting Point, °C	: 185
Specific Gravity	: 1.38-1.55
Specific Heat, cal/g °C	: 0.55
Thermal Conductivity, cal/cm ² ,s, °C/cm *10 ⁻⁴	: 3-5
Coefficient of Linear Expansion, in/in/°C	: 5.0-25.0
Elongation, %	10-50
Tensile Modulus, psi	: 145000-5100000
Tensile strength, psi	: 48000-54000
Impact strength, ft lb/in, 1/2" bar	: 0.4-22
Flexural Strength, psi	: 12000
Compressive Strength, psi	: 9000
Abrasion Resistance	: very good
Dielectric Strength, Kv/mm	: 35-50
Dielectric Constant @ 60 Hz	: 3.2-3.6
Water Absorption, 24 h, 1/8" thick,%	: 0.15-0.75
Chemical Stability, resistant to acids:	excellent
	bases: good
	sunlight: excellent
Toxicity:	most grades meet FDA requirements for food use.

Sources: (2,6,11).

Table VI. Properties of Polypropylene.

Melting Point, °C	: 176
Specific Gravity	: 0.90-0.907
Specific Heat, cal/g °C	: 0.32
Thermal Conductivity, cal/cm ² ,s, °C/cm *10 ⁻⁴	: 2.8
Coefficient of Linear Expansion, in/in/°C x 10 ⁻⁵	: 5.8-10.2
Elongation, %	20-800
Tensile Modulus, psi	: 160000-190000
Tensile strength, psi	: 3100-5700
Impact strength, ft lb/in, 1/2" bar	: no break
Flexural Strength, psi	: 5300
Compressive Strength, psi	: 5500-8000
Abrasion Resistance	: GOOD
Dielectric Strength, Kv/mm	: 50-56
Dielectric Constant @ 60 Hz	: 2.2-2.6
Water Absorption, 24 h, 1/8" thick,%	: <0.01-0.03
Chemical Stability, resistant to acids:	GOOD
	bases: excellent
	sunlight: poor, crazes
Toxicity:	some grades meet FDA requirements for food use.

Sources: (2,6,11).

Table VII. Properties of Polystyrene.

Melting Point, °C	: 240
Specific Gravity	: 1.05
Specific Heat, cal/g °C	: 0.29
Thermal Conductivity, cal/cm ² s per °C cm *10 ⁴	: 2.4-3.3
Coefficient of Linear Expansion, in/in/°C x 10 ⁻⁵	: 6.0-8.0
Elongation, %	3-4
Tensile Modulus, psi	: 400000-600000
Tensile strength, psi	: 65100-9400
Impact strength, ft lb/in, 1/2" bar	: 0.25-0.40
Flexural Strength, psi	: 480000
Compressive Strength, psi	: 120
Abrasion Resistance	: POOR
Dielectric Strength, Kv/mm	: 300-700
Dielectric Constant @ 60 Hz	: 2.45-2.65
Water Absorption, 24 h, 1/8" thick,%	: 0.03-0.05
Chemical Stability, resistant to acids:	good for some
	bases: excellent
	sunlight: decoloration
Toxicity:	some grades meet FDA requirements for food use.

Sources: (2,6,11).

Table VIII. Properties of Polyurethane.

Melting Point, °C	: 230
Specific Gravity	: 1.2
Specific Heat, cal/g °C	: 0.12
Thermal Conductivity, cal/cm ² ,s,°C/cm *10 ⁻⁴	: 7.4
Coefficient of Linear Expansion, in/in/°C	: 10.0-20.0
Tensile Modulus, psi	: 102000
Tensile strength, psi	: 4350-5800
Impact strength, ft lb/in, 1/2" bar	: no break
Flexural Strength, psi	: 60 (foam)
Compressive Strength, psi	: 40
Abrasion Resistance	: VERY GOOD
Dielectric Strength, Kv/mm	: 30-60
Dielectric Constant @ 60 Hz	: 0.276
Water Absorption, 24 h, 1/8" thick,%	: 0.61-0.8
Chemical Stability, resistant to acids:	good for weak
	bases: good for weak
	sunlight: poor
Toxicity:	some grades meet FDA requirements for food use.

Sources: (2,6,11).

Table IX. Properties of Polyethylene Terephthalate.

Melting Point, °C	: 265
Specific Gravity	: 1.37
Specific Heat, cal/g °C	: 0.25
Thermal Conductivity, cal/cm ² ,s,°C/cm *10 ⁻⁴	: 3.36
Coefficient of Linear Expansion, in/in/°C	: 25.0
Elongation, %	50-300
Tensile Modulus, psi	: 450000
Tensile strength, psi	: 6820
Impact strength, ft lb/in, 1/2" bar	: NO BREAK
Flexural Strength, psi	: 16300
Abrasion Resistance	: good
Dielectric Strength, Kv/mm	: 42
Dielectric Constant @ 60 Hz	: 3.65
Water Absorption, 24 h, 1/8" thick,%	: 0.05-0.130
Chemical Stability, resistant to acids:	very good
	bases: good

Toxicity: some grades meet FDA requirements for food use.

Sources: (2,6,11).

7. SOLUBILITY OF POLYMERS

The solution process of a polymer is a diffusion-controlled mechanism which occurs when polymer molecules are separated, leaving spaces which are occupied by solvent molecules (8). Once a polymer interacts with a "good solvent", its structure which exhibits segmental motion is opened and the solvent moves into the polymer. Attracting forces in the polymer segments are changed by attractive molecular forces polymer-solvents. Complete solution occurs when all polymer molecules are separated from other polymer molecules (27).

Plastics present different solubility depending upon their chemical structure. Polymers with linear amorphous structure are easy to dissolve in different organic solvents yet crystalline polymers only dissolve under certain temperature conditions. The explanation for this behavior is the attractive forces in the crystalline structure are higher than the forces due to the interaction of polymer-solvent. Crystalline polymers can be dissolved at temperatures above their melting point, when molecules from the crystalline structure have been separated (7). If the polar forces in hydrogen bonding are strong enough the polymer may dissolve above the melting point and still remain in solution when it is cooled again. The interaction between polar crystalline polymers and polar solvents provides the energy needed to achieve dissolution of

the polymer.

There is a critical solution temperature below which two phases of polymer-solvent appear. No complete solution occurs in this case. By increasing temperature, solubility in all proportions is obtained (8).

From a thermodynamic point of view the following expression (27) governs the solution process for the polymer-solvent:

$$\Delta G_m = \Delta H_m - T \Delta S_m$$

where,

- ΔG_m is the free energy change
- ΔH_m is the enthalpy change
- ΔS_m is the entropy change upon mixing
- T is the absolute temperature.

ΔG must be negative for the process to occur spontaneously. If the entropy of the system increases considerably and enthalpy exhibits a small increase, ΔG is negative and the process will continue. A decrease in enthalpy will also favor spontaneity.

For polymer-solvents systems the entropy of mixing is always positive (27) tending to make ΔG_m negative. Therefore, the important factor in determining solubility is the enthalpy change. The enthalpy value depends on the solubility parameter of both polymer and solvent. The solubility parameter is defined as the square root of the

cohesive energy density (molar energy of vaporization per molar volume) (32).

$$S = \sqrt{E/V}$$

where, S = solubility parameter
 E = molar energy of vaporization
 V = molar volume

Hildebrand and Scott (5,14,15) introduced the concept of solubility parameter to explain solubility. According to the theory of Hildebrand (5,35), solvency is maximum when solubility parameters of solute and solvent are the same. He developed his theory considering that the dispersion forces between molecules are predominant although dipole or hydrogen interactions occur and must be considered (34).

For the system plastic-solvent, the solubility parameter theory predicts that the best solvent for a given polymer is one whose solubility parameter is equal or close to that of the polymer (27). This theory considers dispersion forces between molecules as the main interaction.

Possible interactions between solvent and solute are (35):

- dispersion (London) forces (holding non-polar molecules)
- dipole interactions (between molecules with permanent dipoles moments)

-hydrogen bonding (from weak chemical bonding)

Many workers consider that polar forces are relatively small in comparison to dispersion and hydrogen bonding. Solvent mixtures are also used to dissolve plastics. When molar volumes of each solvent are equal, the solubility parameter of the mixture is:

$$S_{\text{mixture}} = \sum X_i \cdot S_i$$

where,

X_i = mole fraction of component i

S_i = solubility parameter of component i

Different methods involving the concept of solubility parameter have been proposed to predict plastics solubilities in different solvents (5,27,29,35,36). Some of these methods are presented.

8. METHODS FOR EVALUATING SOLUBILITY PLASTICS-SOLVENT

SEYMOUR'S METHOD.

Seymour (31) presented a method based upon the Hildebrand solubility parameter concept assuming regular solutions behavior. These kinds of solutions are of moderately non polar compounds with constant changes or no changes in entropy (34).

According to this theory when the solubility parameter values for a plastic and solvent are similar, solubility may occur. The solubility parameter values are solubility parameter ranges of polymers in hydrogen-bonded solvents which are classified as poor, moderate, and strong.

Tables X and XI show solubility parameter values for some plastics and solvents.

Table X . Approximate solubility parameter values for several plastics (31).

PLASTIC	Weak H bonds	Moderate H bonds	Strong H bonds
Polyethylene	7.7-8.2	-	-
Polystyrene	8.5-10.6	9.1-9.4	-
Polyvinyl Chloride	8.5-11.0	7.8-10.5	-
Mylar PET	9.5-10.8	9.3-9.9	-
Polyurethane	9.8-10.3	-	-

Table XI. Solubility Parameter Values for Solvents (31)

Solvent	Solubility Parameter
Hydrocarbons (poor H bonds)	
Hexane	7.3
Toluene	8.9
Ethyl Benzene	8.8
Xylene	8.85
Ketones (moderate H bonds)	
Acetone	10.0
Methyl Ethyl Ketone	9.3
Methyl Isobutyl Ketone	8.4
Methyl Isoamyl Ketone	8.3
Cyclohexanone	9.9
Ethyl Amyl Ketone	8.2
Diisobutyl Ketone	7.8
Isophorone	9.1
Esters (moderate H bonds)	
Methyl Acetate	9.6
Ethyl Acetate	9.1
Isopropoyl Acetate	8.6
n-propyl Acetate	8.75
s-butyl acetate	8.2
i-butyl acetate	8.3
n-butyl acetate	8.5

Table XI. (Continuation)

Alcohols (strong H bonds)

Methyl alcohol	14.5
Isopropyl alcohol	11.5
n-propyl alcohol	11.9
i-butyl alcohol	10.7
n-butyl alcohol	11.4
n-amyl alcohol	10.9
Cyclohexanol	11.4

Miscellaneous (weak H bonds)

Dichloromethane	9.7
Chloroform	9.3
1,2 dichloroethane	9.8
2-nitropropane	9.9

Data from Tables X and XI can be used to predict plastic-solvent solubility. To dissolve PET, for example, its solubility parameter value is obtained from Table X. In Table XI is listed the solvent which has the same solubility parameter. Thus, Methyl Ethyl Ketone has a solubility parameter of 9.3 for moderate hydrogen bonds. Similarly, Cyclohexanone has a solubility parameter of 9.9. Since PET has a solubility partameter of 9.3-9.9 for moderate hydrogen bonds, these solvents are good candidates for dissolution.

This method is recommended when solubility of an

amorphous plastic is needed. For highly crystalline plastics which have strong molecular interactions, the method is not accurate (31).

This model is not very accurate because it neglects entropy effects and considers only hydrogen bond parameter to describe solubility.

HYDROGEN BONDING POTENTIAL(HBP) MODEL

This model presented by Ryder (29) is a practical method to predict solubility of resins in organic solvents. The enthalpy of hydrogen bond formation between a solvent and the resin is written as

$$-\Delta H = b \times C$$

considering that the hydrogen bond is formed by the reaction of a proton-donor agent and a proton acceptor agent. In this relationship b is a donor parameter and C is an acceptor parameter.

This method assumes that among dispersion, polar, and hydrogen bonding interactions, hydrogen bonding represents the main factor in determining solubility behavior because it is the most energetic and it is closely related to the concept of chemical reaction (29).

The HBP model, different from other methods, assigns to the hydrogen bonding the dual characteristic of donating and accepting tendency.

The equation that is the basis of this HBP model is

$$\text{HBP} = (b_1 - b_2)(C_1 - C_2)$$

and it represents the hydrogen bonding interaction of the solute and solvent. If HBP is negative, the hydrogen bonding is favorable between the two compounds and there is a tendency to form solutions. However, if the value of HBP is positive no solution is formed.

After eliminating parenthesis in the previous equation two positive terms b_1C_1 and b_2C_2 result. As the subscripts indicate they represent association of the same component i through hydrogen bonding (no interaction with the other component). Therefore, positive terms won't favor solution. The other two terms b_1C_2 and b_2C_1 are negative favoring solution and represent the interactions between the solvent and the solute.

HBP model can be applied to polymers if values of b and C are known. Hansen (10) and Rider (29) present values for the parameters b and C for solvents and some resins.

An extension of this model is a graphical method based on the equation described above for the HBP model. Figure 1 shows a plot of b versus C for pure solvents.

Lines vertical and horizontal represent the b and C parameters for a given polymer. These two lines divide the plane into four regions; in two of which the polymer will dissolve (negative HBP) and in two of which solubility will not occur (positive HBP). Therefore, there are two areas of

solubility and two areas of insolubility.

Figure 1. Solubility Map

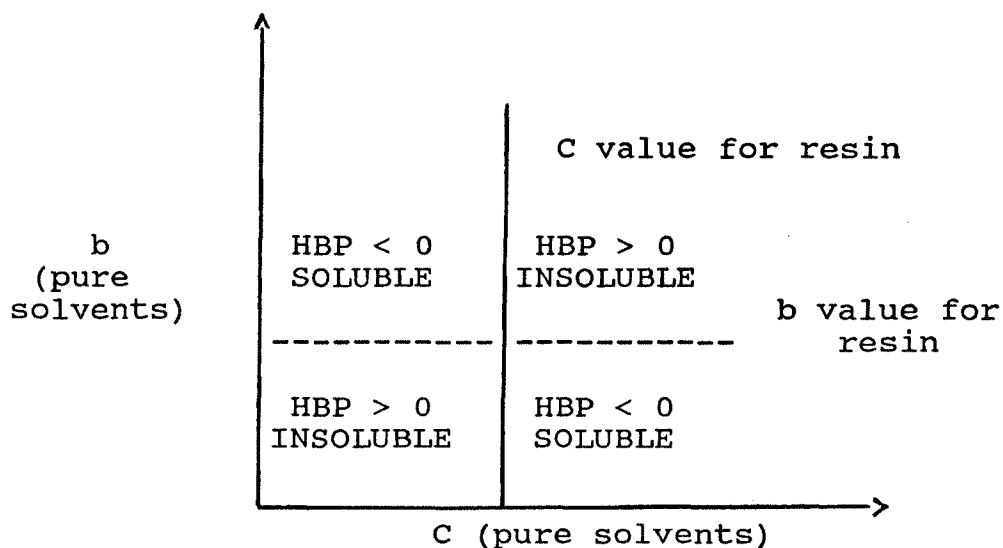

When values of b and C for a solvent are plotted they represent one point. Depending where this point lies the solvent can or cannot dissolve the polymer.

METHOD IN MODERN PLASTICS ENCYCLOPEDIA

Another method is presented in the Modern Plastics Encyclopedia (22) in which data are presented to predict solubility of selected resins in selected solvents. These tables contain information about solvents, their corresponding solubility parameter and type of hydrogen bonding that they exhibit. Similarly for resins, tables present data for selected resins such as range of solubility parameter according to poor, moderate, and strong hydrogen

bonding with solvents.

This information is used to predict solubility according to the following procedure:

- a) determine solubility parameter of the solvent and the type of hydrogen bonding poor, moderate, or strong.
- b) if the solubility parameter of the solvent lies between the solubility parameter range of the resin in the corresponding type of hydrogen-bonded, solution of the resin in the solvent would occur.

This method is based on the same principle than Seymour's model described before. Therefore, with reference to Tables IX and X possible solvents for PVC solution with moderate hydrogen bonds (solubility parameters range for PVC 7.8-10.5) are the ketones and esters which have solubility parameters value (for the same type of hydrogen bonding) between 7.8 and 10.5.

HANSEN'S THREE DIMENSIONAL SOLUBILITY PARAMETER METHOD

As mentioned before, methods assuming only hydrogen bonding interaction do not consider other forces that hold the structure together and are responsible for the energy of vaporization which is related to the solubility parameter.

Hansen (27), considers three kind of forces and classified solvents and polymers according to their contributions in dispersion (d), polar (p), and hydrogen bonding (h) (10,27)

The total solubility parameter is found using the equation

$$s = \sqrt{s_d^2 + s_p^2 + s_h^2}$$

Table XII presents solubility parameters for some solvents.

Table XII. Solubility Parameters for Some Solvents (27).

Solvent	S _d	S _p	S _h
Ethanol	7.73	4.3	9.5
Ethyl Acetate	7.44	2.6	4.5
Acetone	7.58	5.1	3.4
Methyl Ethyl Ketone	7.77	4.4	2.5
Dimethylformamide	8.52	6.7	5.5
Benzene	8.95	0.5	1.0

Hansen developed a graphical method which consists of plotting in a threedimensional plane the values of S_d, S_p and S_h. In the plot the distance on the S_d axis is twice the distance on S_p and S_h axes. By plotting values of S_d,

S_p , and S_h for a particular polymer a point P is determined. Around this point a sphere is constructed as is shown in Figure 2. The radius of the sphere has been found experimentally for different systems testing solubility of a given resin in different solvents (10).

Figure 2. Hansen's Three-Dimensional Solubility Parameter Plot.

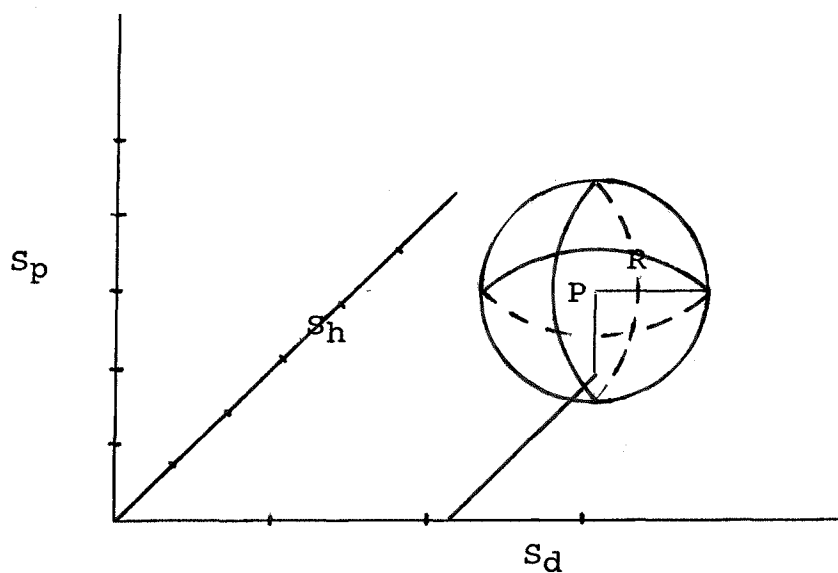

Any solvent with a point determined by its corresponding S_d ,

S_p and S_h lying within the sphere is a good solvent for the polymer. If the point lies outside of the sphere the solvent doesn't dissolve the polymer.

9. CHOOSING A SOLVENT

Some physical properties and selectivity of the solvent should be considered during the process of selection. Among the physical properties are cost, toxicity, availability, boiling point, viscosity, density and flammability. Selectivity refers to the particular solubility of a component in a mixture by a solvent.

Before selecting a solvent it is necessary to analyze carefully health hazards. After an optimum selection, good manufacturing procedures and industrial hygiene practice are very important to ensure security.

The selection of a solvent for a specific plastic depends upon the practical point of view because the properties of the resin change according to the size of the monomer unit, chemical structure, temperature, agitation. Therefore experimentation is needed in all cases. Solubility normally increases when temperature is raised. However, the inverse behavior for some solvents have been observed (2).

Basic information about solubility is:

- increase molecular weight reduces solubility
- polymer with branched structure is more soluble than linear polymer
- mixture of good solvents for a resin can become non-solvent for the same resin, and mixture of non-solvents can become good solvents.

The following qualitative data presents solvents and non-solvents for HDPE, LDPE, PP, PVC, and PET at room temperature unless specified (2).

TYPE	Solvents	Non-solvents
HDPE	above 80°C: hydrocarbons, halogenated hydrocarbons, high aliphatic esters and ketones.	All common organic solvents at room temperature, more polar organic solvents even at elevated temperatures, inorganic solvents, dimethylformamide.

TYPE	Solvents	Non-solvents
LDPE	As above but temperature 20-30°C lower depending on degree of branching.	As above.
PP	Atactic: hydrocarbons, chlorinated hydrocarbons at room temperature, isoamil acetate, diethyl ether.	More polar organic solvents even at high temperatures, anorganic solvents, dimethylformamide
PVC	Tetrahydrofuran (THF), Methyl Ethyl Ketone (MEK),	Hydrocarbons, vinyl chloride, alcohols, acetone (swellen)
HIGH MW	cyclopentanone, Dimethyl Formamide (DMF), nitrobenzene, dimethylsulfoxide(DMSO)	esters, carbon disulfide.
LOW MW	Toluene, ethylene chloride DMF, nitrobenzene, DMSO, perchloroethylene/acetone.	
PET	Phenol, chlorophenol, DMSO, phenol/tetrachloroethane(1:1 vol), nitrobenzene, phenol/trichlorophenol (10:7 vol).	Hydrocarbons, aliphatic alcohols, ketones, carboxylic esters, ethers.

CHAPTER II

PROCESS DESCRIPTION

The separation process consists of a serie of steps which allows the individual separation of LDPE, PVC, HDPE, PP, PS, PU, and PET from a mixture of commingled plastics.

The proposed flow diagram of the process of separation is shown in Figure 3.

According to Figure 3, the following steps describe how these seven thermoplastics can be separated.

STEP I: WASTE SEPARATION FROM SEVEN MAJOR PLASTICS

Distribution of plastics in the feed stream appears in left side of table XIII. A heterogeneous waste plastic mixture is sorted into the relatively pure seven generic types. In the same way plastics materials different from HDPE, PVC, LDPE, PP, PS, PU, and PET are separated as waste material by means of a sorting system and discharged. Parameters that can be used to sort are density, color, transparency, reflectivity, object size, object shape, hardness, flexibility, electrical properties, labelling or encoded information.

STEP II: HDPE, PVC, AND PET BOTTLES SEPARATION.

After separating undesired plastics, the next step is the segregation of bottles made of HDPE,PVC, and PET. These

NOMENCLATURE IN FIGURE 3

AC	= Air cyclone
B	= Bottles separation
BSORT	= Bottles sortation by color and type
C	= Cyclone
CO	= Cooler
D	= Dryer
F	= Filter
G	= Granulator
HC	= Hydrocyclone
R	= Rinse
S	= Shredder
SC	= Sludge hydrocyclone
SD	= Spin drier
TK	= Slurry tank
W	= Waste separator
WASH	= Washer

Fig. 3. Proposed flow Diagram of the Entire Process.

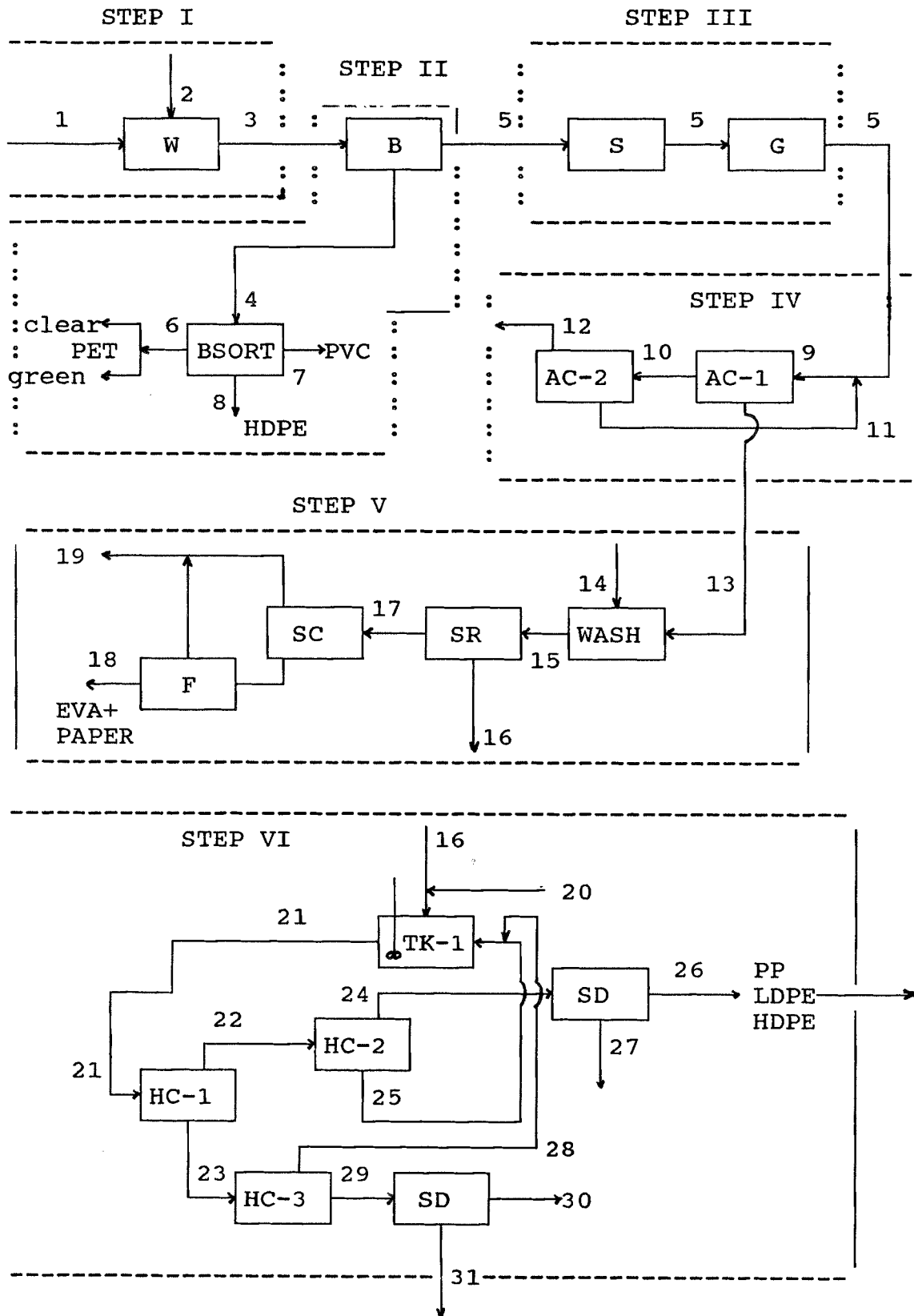

Fig.3 (continuation)

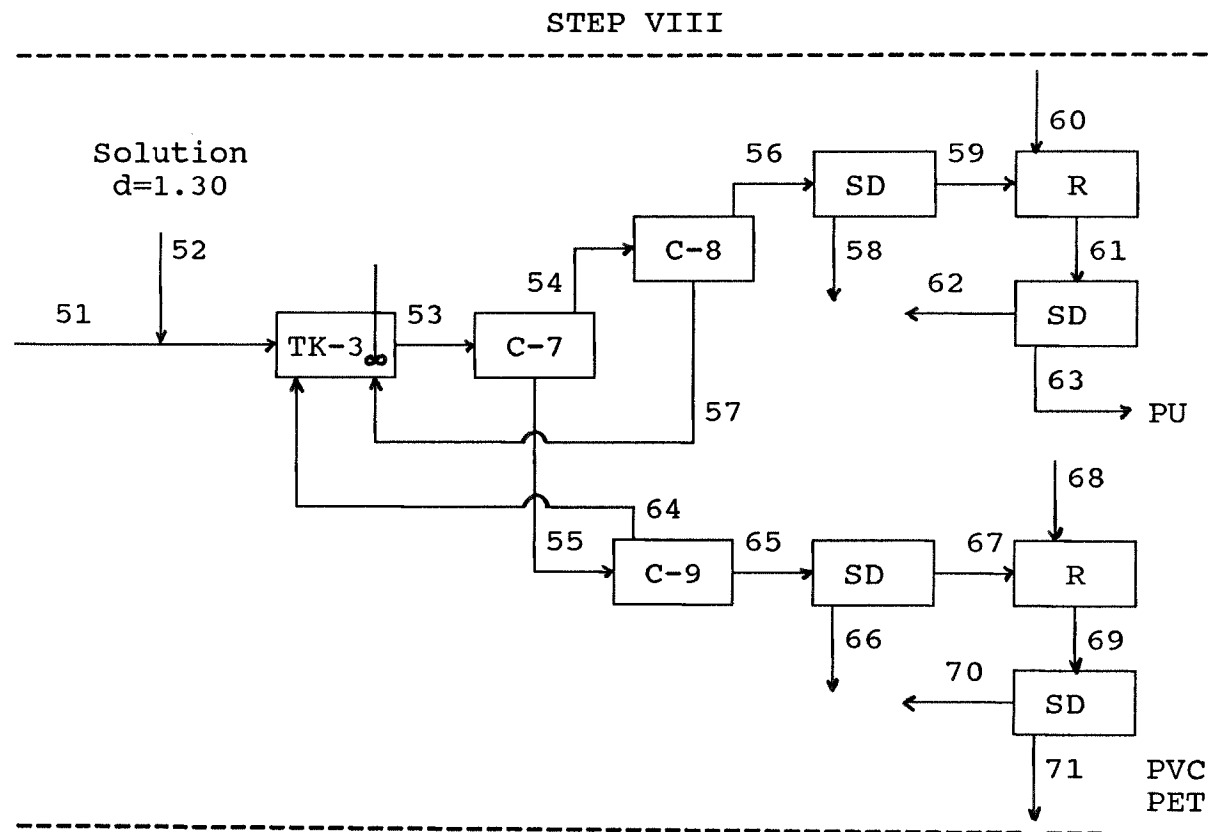
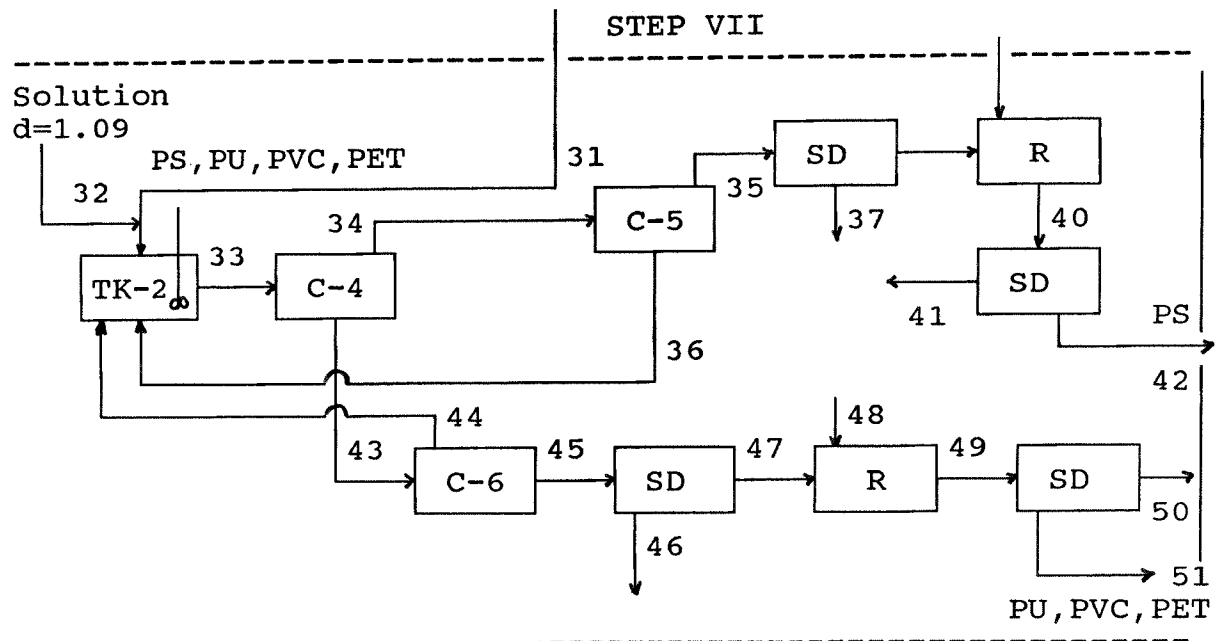
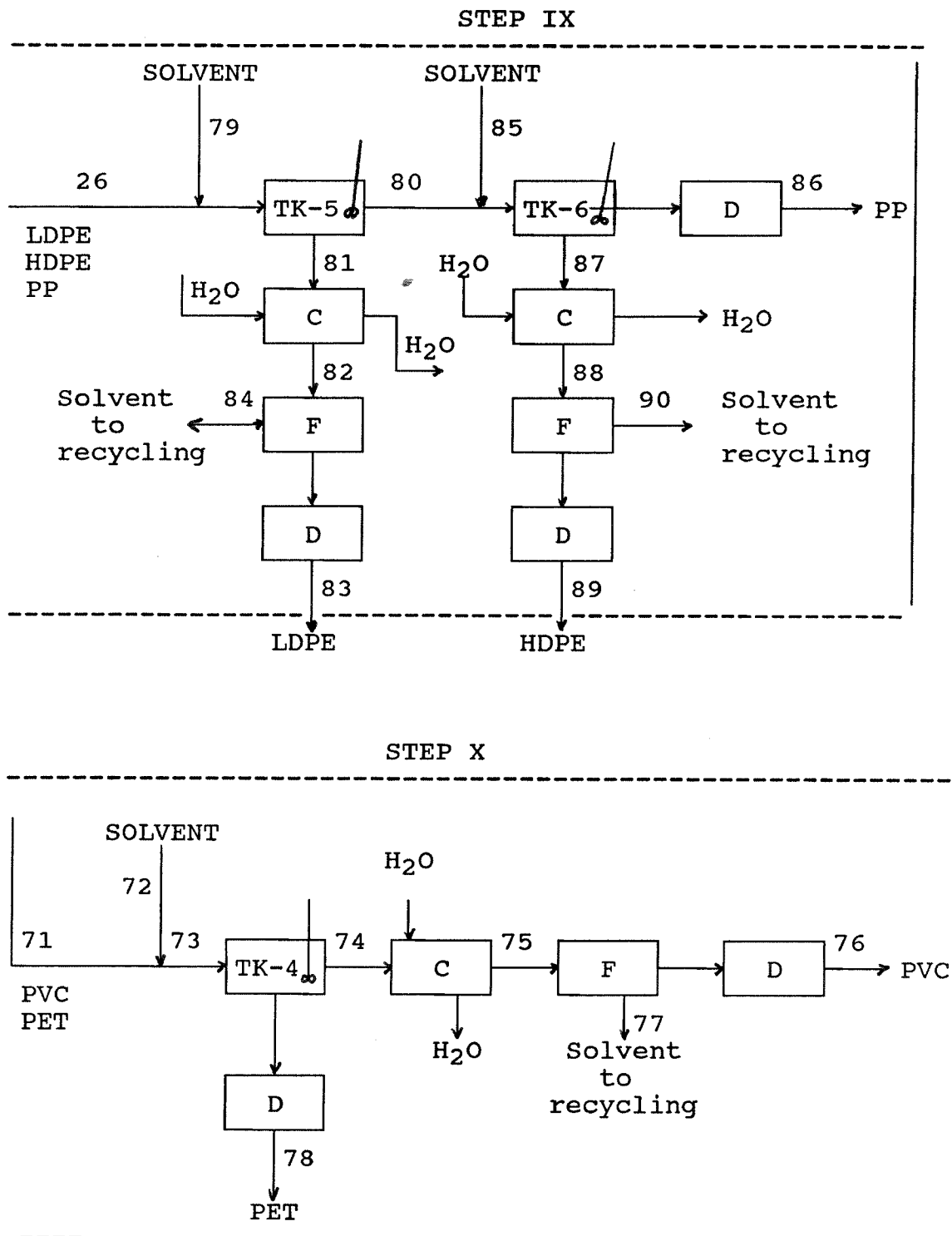

Fig 3. (continuation)



bottles (milk,soda,etc) are easy to identify visually. PET bottles are also classified in clear and green color. Once HDPE,PVC and PET bottles are separated they are baled and stored as finished product to be used in other processes which require unmixed plastics.

All aluminum that enters to the process is separated with the bottles. In addition, it is assumed that fifty percent of both paper and EVA stay with the bottles and the other fifty percent goes to the next step.

This step is less complicated when whole bottles are collected because it facilitates segregation by color before granulation.

STEP III: SHREDDING AND GRANULATION

After the bottles are recovered, the stream containing the seven major plastics LDPE, PVC, HDPE, PP, PS, PU, and PET is prepared for a new step of separation. The mixture is shredded and then granulated into chips. The particle size of the chips is very important to ensure free path through pipes and equipments in subsequent processing. A surface area under 0.25 in^2 avoids bridging and plugging during the processing(33).

STEP IV: AIR CYCLONES, 50% PAPER SEPARATION

The granulated mixture of plastics is fed to a two-air

cyclone unit. This unit removes fifty percent of the entering paper labels. Paper can be sent to a separate processor or to an incinerator.

STEP V: WASHING

Plastics chips containing paper and EVA are sent to a wash tank where a detergent solution (normally a hot basic solution like Oakite detergent) dissolves paper which is not removed in air cyclones, adhesive and residual syrup. Solids concentration in wash tank is 0.5 lb per gallon of detergent solution.

The plastics chips are removed from the wash solution and purified in a rinse cycle.

Paper and EVA are completely separated from the wash solution by using a sludge hydrocyclone and then passing through a paper filter.

Water and wash solution are first filtered and then recycled.

STEP VI: SEPARATION OF PLASTICS LESS DENSER THAN WATER FROM PLASTICS MORE DENSER THAN WATER.

The density of thermoplastics can be used as a driving force for separating the mixture in aqueous solution. Table XIII shows ranges of density for PP, LDPE, HDPE, PS, PU, PET, and PVC.

Table XIII. Density Ranges of Virgin Plastics

TYPE	DENSITY
PP	0.90
LDPE	0.91-0.92
HDPE	0.94-0.96
PS	1.05
PU	1.20
PET	1.37
PVC	1.38-1.55

Although additives may change densities, experiments have demonstrated that density values remain in these ranges (38).

Washed plastic chips pass to an agitated tank where they are suspended in water. The slurry (plastics and water) then passes to a series of three hydrocyclones in which density of the liquid is equal to 1.0. In each hydrocyclone, light materials LDPE, HDPE, and PP with densities less than 1.0 are present in the overflow and the heavies PS, PU, PVC, and PET with densities greater than 1.0 flow through the bottom of hydrocyclones.

The overflow of the second hydrocyclone containing the light fraction is dewatered in a spin drier. Similarly the

heavy fraction is passed by a spin drier for the same purpose.

To avoid plugging the concentration of solids in the slurry tank is 0.5 lb solids per gallon of water.

STEP VII: POLYSTYRENE SEPARATION

The heavy fraction from previous step containing PS, PU, PVC, and PET is sent to another slurry tank where the the plastics are suspended in an aqueous solution of density equal to 1.09. By using cyclones PS with density less than 1.09 is separated in the over flow from the other resins. A spin drier removes liquid separating PS from the light stream. The PS is then rinsed with water and dried, preparing PS chips to be stored as final product.

The slurry heavy fraction containing PU, PVC, and PET passes through a spin drier where solids are separated from the solution. After rinsing with water, a dryer completes the cleaning and PU, PVC and PET go to next step that separates PU.

The solution and water are filtered and recycled during the process.

STEP VIII: POLYURETHANE SEPARATION

This step is similar to that described above for PS purification. The only difference is that the solution used

to suspend plastics chips in slurry tank has a density equal to 1.30. In this step lights PU chips with density equal to 1.20 are separated from PVC, and PET which have densities greater than 1.30

Both light and heavy streams are cleaned obtaining PU as final product. Similarly, solution used in slurry tank and rinse water return to the system to be recycled.

STEP IX: LOW DENSITY POLYETHYLENE (LDPE), HIGH DENSITY POLYETHYLENE (HDPE) AND POLYPROPYLENE (PP) SEPARATION BY USING SOLVENT

The light fraction of step VI which contains PP, HDPE, and LDPE are difficult to separate using difference in density as driving force. Instead of this, it is possible to achieved separation using solvents for different polyethylenes with PP (24).

Mixed chips of these three plastics and a selective solvent like MEK are introduced into a stirred tank where temperature is increased to a value of 60°C at which LDPE dissolves. HDPE and PP remains as solid particles. On cooling, LDPE separates from its solution and solvent is separated by centrifugation or a filter. LDPE is finally dried and stored.

A solvent to separate HDPE and PP like aniline is fed into another stirred tank with these two resins where temperature of the system is increased to about 66°C until complete solution of HDPE chips. Solid PP is removed and

the solution is cooled to precipitate HDPE. After centrifugation to remove the solvent, solid HDPE is dried and stored as final product. Sometimes during the process it is necessary to use two stages to get complete separation with solvent (20).

Recovered LDPE, HDPE, and PP can be bagged or pelletized as products of the process.

STEP X: POLYVINYLCHLORIDE (PVC) AND POLYETHYLENE TEREPHTHALATE (PET) SEPARATION BY USING SOLVENT

Once Polyurethane (PU) is separated from PVC and PET, these two components enter a new stage where a solvent is used to separate them as pure resins. By using a specific solvent like DMF, PVC (soluble) can be separated from PET. After removing PET from the PVC solution, PVC is precipitated by reducing the temperature of the solution. Once PVC precipitates, the mixture is centrifugated or filtered to remove the solvent. After drying, PVC is stored or pelletized. Similarly, PET is dried and stored as final product.

CHAPTER III
DISCUSSION OF CALCULATIONS

In order to fix the composition of the feed stream, information from Modern Plastics sales report (28) is taken as a good approximation. United States plastics sales in 1989 represented about 60 billion pound as shown in table XIV.

Table XIV. U.S. Plastics Sales 1989 (28).

Material	Million lb
ABS	1243
Acrylic	739
Alkyd	325
Cellulosics	91
Epoxy	429
Nylon	595
Phenolic	3162
Polyacetal	141
Polycarbonate	622
Polyester, thermoplastic (PET)	1905
Polyester, unsaturated	1325
Polyethylene, high density	8115
Polyethylene, low density	10636

Table XIV. (continuation)

Material	Million lb
Polyphenylene-based alloys	176
Polypropylene and copolymer	7246
Polystyrene	5184
Other styrenics	1170
Polyurethane	3245
Polyvinyl Chloride and copolymers	8307
Other vinyls	960
Styrene acrylonitrile (SAN)	137
Thermoplastics elastomers	542
Urea and melamine	1367
Others	307
Total	58228

This table includes a wide variety of thermoplastic and thermoset resins. Because the interest of this work is on thermoplastics materials, it only considers seven major thermoplastic types as forming the mixture to be further separated in individual resins once others are discarded as waste material. Table XV presents the seven major thermoplastic materials extracted from Table XIV, and their percentages of the total plastic stream.

Table XV. Seven major thermoplastics types

Type	Million lb	%
Low Density Polyethylene (LDPE)	10636	18.27
Polyvinyl Chloride (PVC)	8323	14.29
High Density Polyethylene (HDPE)	8115	13.94
Polypropylene (PP)	7246	12.44
Polystyrene (PS)	5184	8.90
Polyurethane (PU)	3245	5.57
Polyethylene Terephthalate (PET)	1905	3.27
	-----	-----
Total	44654	76.68

The composition of this plastics mixture represents their distribution in the feed stream of the process.

The feed stream, which is a collection of the different plastics (see Table XIV) is fixed at 50,000,000 pounds/yr as mass flow entering to the process. Based on this number and on their percentages, the amount in pounds/yr of the seven major plastics (others are not included) appears in table XVI.

Table XVI. Seven major plastics in pounds/yr based on
50,000,000 pounds/yr of mixed plastics entering
to the process.

Type	%	pounds/yr
LDPE	18.27	9,135,000
PVC	14.29	7,145,000
HDPE	13.94	6,970,000
PP	12.44	6,220,000
PS	8.90	4,450,000
PU	5.57	2,785,000
PET	3.27	1,635,000
Others	23.32	11,660,000
	-----	-----
Total	100.00	50,000,000

APROXIMATE AMOUNT OF ALUMINUM, PAPER AND EVA

Aluminum from cups, paper from labels, and ethylene vinyl acetate (EVA) from adhesive are also present as part of beverage containers and other kind of bottles.

Based on the composition of a 2-liter beverage bottles and on the amount of PET from beverages bottles that enter to the process, the amount of aluminum, paper and EVA are calculated.

Figure 4 shows the components of a 2-liter beverage bottle.

Figure 4. Composition of a Typical 2-liter PET Beverage Bottle (26).

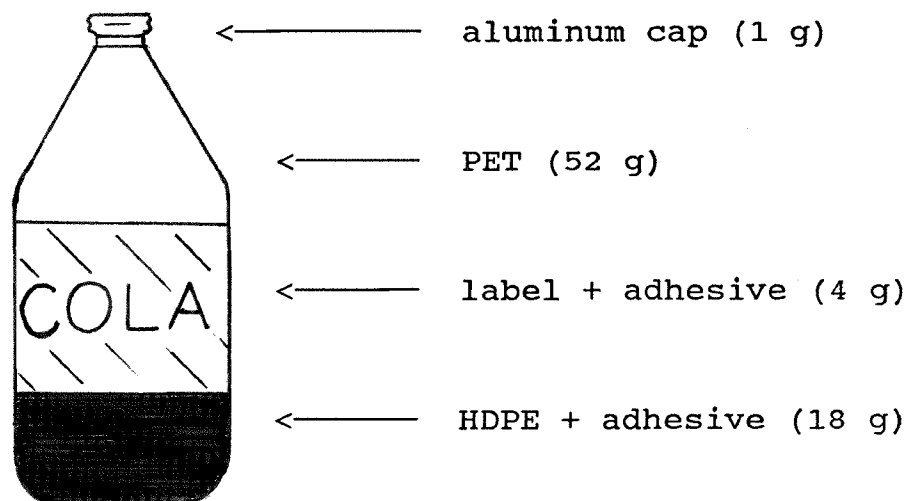

During 1989, consumption of PET in soft drink bottles was 680 million of pounds (28). The relative amount of PET from bottles to total plastics sales (see total sales in Table XIV) is:

$$(680,000,000 \text{ lb/yr} / 58,228,000,000 \text{ lb/yr}) = 0.01168$$

This factor is used to determine the amount of PET that enters the process in the form of soft drink containers as part of the 50,000,000 lb/yr:

$$(50,000,000 \text{ lb/yr}) (0.01168) = 584,000 \text{ lb/yr}$$

The following information is taken from Figure 4:

PET	52 g
Al	1 g
paper + adhesive	4 g
HDPE + adhesive	18 g

Total	75 g

According to a CPRR data the amount of EVA in one bottle represents about 4 percent of the total weight.

Then,

$$\text{EVA in one bottle} = (75 \text{ g})(0.04) = 3.0 \text{ g}$$

Assuming that EVA in the adhesive is distributed equally in label and base cups, the composition exhibited in Figure 4 can be written in more details as

PET	52.0 g
Al	1.0 g
paper (4.0 - 1.5)	2.5 g
HDPE (18.0 - 1.5)	16.5 g
EVA	3.0 g

Total	75.0 g

UNIT I: WASTE MATERIAL SEPARATION

The diagram shown in Figure 5 illustrates the first separation step, in which undesired materials (about 23%) are segregated from the stream containing HDPE, LDPE, PVC, PP, PS, PU, and PET.

Figure 5. Waste Material Separation

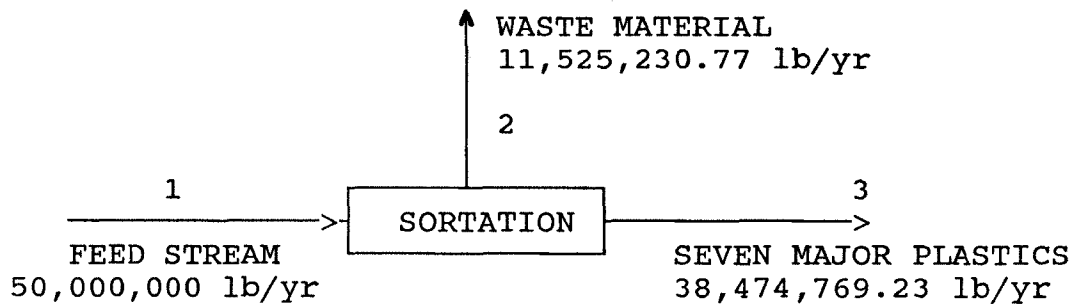

Fixing the plastic stream 3 at 5,000 lb/hr, the time of production and downtime are:

$$(38,474,769.23 \text{ lb/hr}) * (1\text{yr}/A \text{ days}) * (1\text{day}/24\text{hr}) = 5,000 \text{ lb/hr}$$

then,

$$A = \text{time of production} = 320.62 \text{ days}$$

$$\text{or, } (320.62 \text{ days}/365 \text{ days}) * 100 = 87.84\%$$

$$\text{and, } \text{downtime} = 12.16\%$$

Table XVII shows the composition of stream 3 (Figure 5) in lb/hr, based on a total 5,000 lb/hr and 87.84% production time.

Table XVII. Composition of stream 3 in lb/yr and lb/hr.

Component	lb/yr	lb/hr*
LDPE	9,135,000	1,187.15
PVC	7,145,000	928.53
HDPE	6,970,000	905.80
PP	6,220,000	808.32
PS	4,450,000	578.30
PU	2,785,000	361.92
PET	1,635,000	212.47
EVA	67,384.62	8.75
PAPER	56,153.84	7.30
ALUMINUM	11,230.77	1.46

TOTAL		5,000.00

*Conversion factor from lb/yr to lb/hr: 1/7694.88

UNIT II: HDPE, PVC, AND PET BOTTLES SEPARATION

After the seven major plastics separation, the stream is separated again into two new streams. One containing packaging rigid containers of PET, HDPE, and PVC (such as beverage, milk, juice bottles), and other stream containing the rest of plastics that enters a shredder to be separated later into individual resins. Figure 6 presents a diagram of bottles segregation.

Figure 6. Separation of Polyvinyl Chloride (PVC), High Density Polyethylene (HDPE), and Polyethylene Terephthalate (PET) bottles.

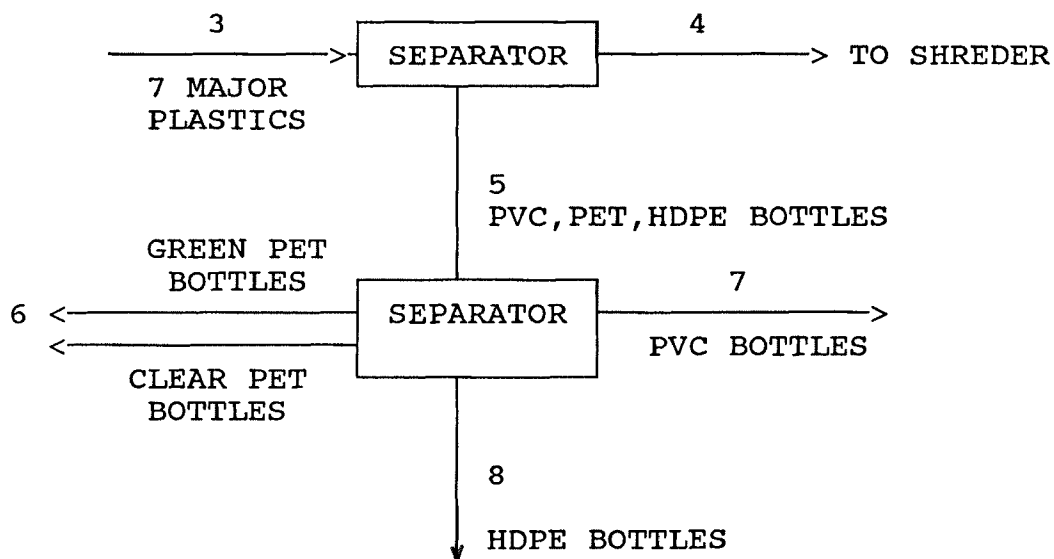

The amount of bottles of each type of resin is found

knowing the individual consumption in blow molded bottles and the amount sold during 1989.

The following information is taken from Modern Plastics (28) and Table XIV.

Type	1989 Blow molded consumption million lb/yr	1989 Amount sold million lb/yr
HDPE	2,424	8,115
PVC	207	8,307
PET	940	1,905

$$\begin{aligned} \text{Then, \%HDPE in bottles} &= (2,424 \times 10^6) (100) / 8,115 \times 10^6 \\ &= 29.87 \end{aligned}$$

$$\begin{aligned} \%PVC \text{ in bottles} &= (207 \times 10^6) (100) / 8,307 \times 10^6 \\ &= 2.49 \end{aligned}$$

$$\begin{aligned} \% \text{ PET in bottles} &= (940 \times 10^6) (100) / 1,905 \times 10^6 \\ &= 49.34 \end{aligned}$$

These percentages represent the first separation of HDPE, PVC, and PET by sortation in the form of bottles.

Then,

$$\text{HDPE bottles separated} = (0.2987) (905.80 \text{ lb/hr}) = 270.56 \text{ lb/hr}$$

$$\text{PVC bottles separated} = (0.0249) (928.53 \text{ lb/hr}) = 3.12 \text{ lb/hr}$$

$$\text{PET bottles separated} = (0.4934) (212.47 \text{ lb/hr}) = 104.83 \text{ lb/hr}$$

The complete material balance for this unit appears in Table XVIII.

Table XVIII. Material Balance Polyvinyl Chloride (PVC), Polyethylene Terephthalate (PET), and High Density Polyethylene (HDPE) Bottles Separation.

STREAMS (lb/hr)						
COMP	3	4	5	6	7	8
LDPE	1187.15	0	1187.15	0	0	0
PVC	928.53	23.12	905.41	0	23.12	0
HDPE	905.80	270.56	635.24	0	0	270.56
PP	808.32	0	808.32	0	0	0
PS	578.30	0	578.30	0	0	0
PU	361.92	0	361.92	0	0	0
PET	212.47	104.83	107.64	104.83	0	0
EVA	8.75	4.37	4.37	4.37*		
PAPER	7.30	3.65	3.65	3.65*		
Al	1.46	1.46	0	1.46*		
TOTAL	5000.00	408.00	4592.00	114.37	23.12	270.56

* Distributed in streams 6, 7 and 8.

UNIT III. PARTIAL SEPARATION OF PAPER BY AIR CYCLONES

Figure 7 shows separation of paper in air cyclones after the mixture of plastics is shredded and granulated.

Figure 7. Partial Separation of Paper.

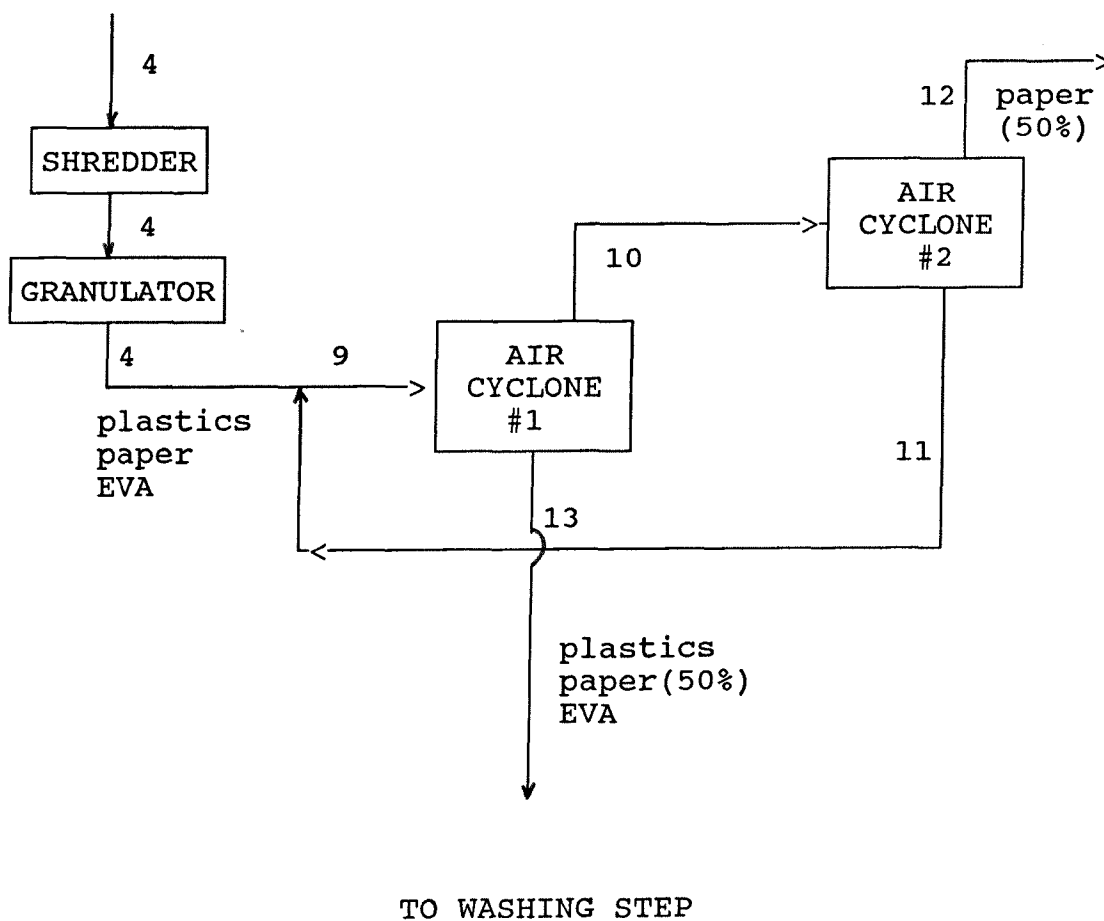

The basic assumptions in this step are:

- a) The two air cyclones in series remove fifty percent of the paper that enters to this unit.
- b) 75% of the paper entering into air cyclone #1 overflows and goes to the second air cyclone. that is, 25% of paper in stream 9 goes with plastics mixture and EVA to washing step.

Table XIX. Material Balance in Air Cyclones Unit.

STREAMS (lb/hr)

COMP	5	9	10	11	12	13
LDPE	1187.15	1187.15	0	0	0	1187.15
PVC	905.41	905.41	0	0	0	905.41
HDPE	635.24	635.24	0	0	0	635.24
PP	808.32	808.32	0	0	0	808.32
PS	578.30	578.30	0	0	0	578.30
PU	361.92	361.92	0	0	0	361.92
PET	107.64	107.64	0	0	0	107.64
EVA	4.37	4.37	0	0	0	4.37
PAPER	3.65	7.30	5.475	3.65	1.825	1.825
TOTAL	4592.00	4595.65	5.475	3.65	1.825	4590.17

UNIT IV: WASHING OF PLASTICS MIXTURE-PAPER AND EVA
SEPARATION

A scheme of washing operation is presented in Figure 8.

Figure 8. Separation of Residual Paper and Ethylene Vinyl
Acetate (EVA).

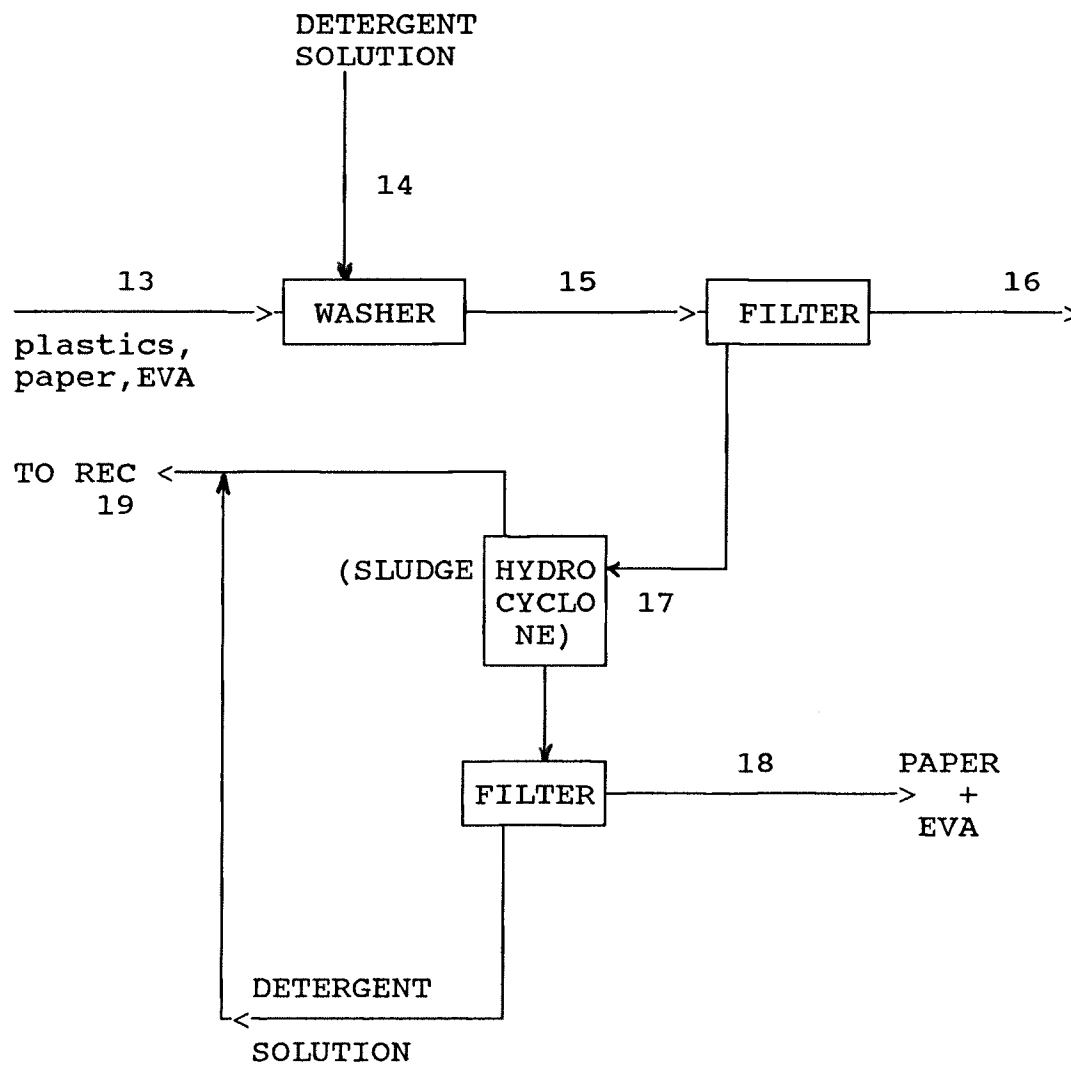

During this operation all paper remaining from the previous stage and all EVA are separated on a paper filter. The concentration in the washer tank is 0.5 lb solids per gallon of detergent solution.

The material balance for this separation appears in Table XX.

TABLE XX. Material Balance Paper and EVA Separation

STREAMS (lb/hr)						
COMP	14	15	16	17	18	19
LDPE	0	1187.15	1187.15	0	0	0
PVC	0	905.41	905.41	0	0	0
HDPE	0	635.24	635.24	0	0	0
PP	0	808.32	808.32	0	0	0
PS	0	578.30	578.30	0	0	0
PU	0	361.92	361.92	0	0	0
PET	0	107.64	107.64	0	0	0
EVA	0	4.37	0	4.37	4.37	0
PAPER	0	1.83	0	1.83	1.83	0
DET SOL.	71912.73	71912.73	0	71912.73	0	71912.73
TOTAL	71912.73	76502.90	4583.98	71918.93	6.20	71912.73

UNIT V: HEAVY AND LIGHT SEPARATION

Mixed plastics chips are suspended in water in the slurry tank in the relation 0.5 lb solids per gallon of water.

The following assumptions have been considered:

- a) Split of water in hydrocyclones is fifty-fifty.
- b) Presence of heavy components PS, PU, PET, and PVC in light fraction is neglected (zero percent).
- c) Efficiencies of hydrocyclones = 99%.

A detailed scheme appears in Figure 9, and the complete material balance for this step is shown in Table XXI.

Figure 9. Separation of Plastics Denser than water from Those Lighter than Water.

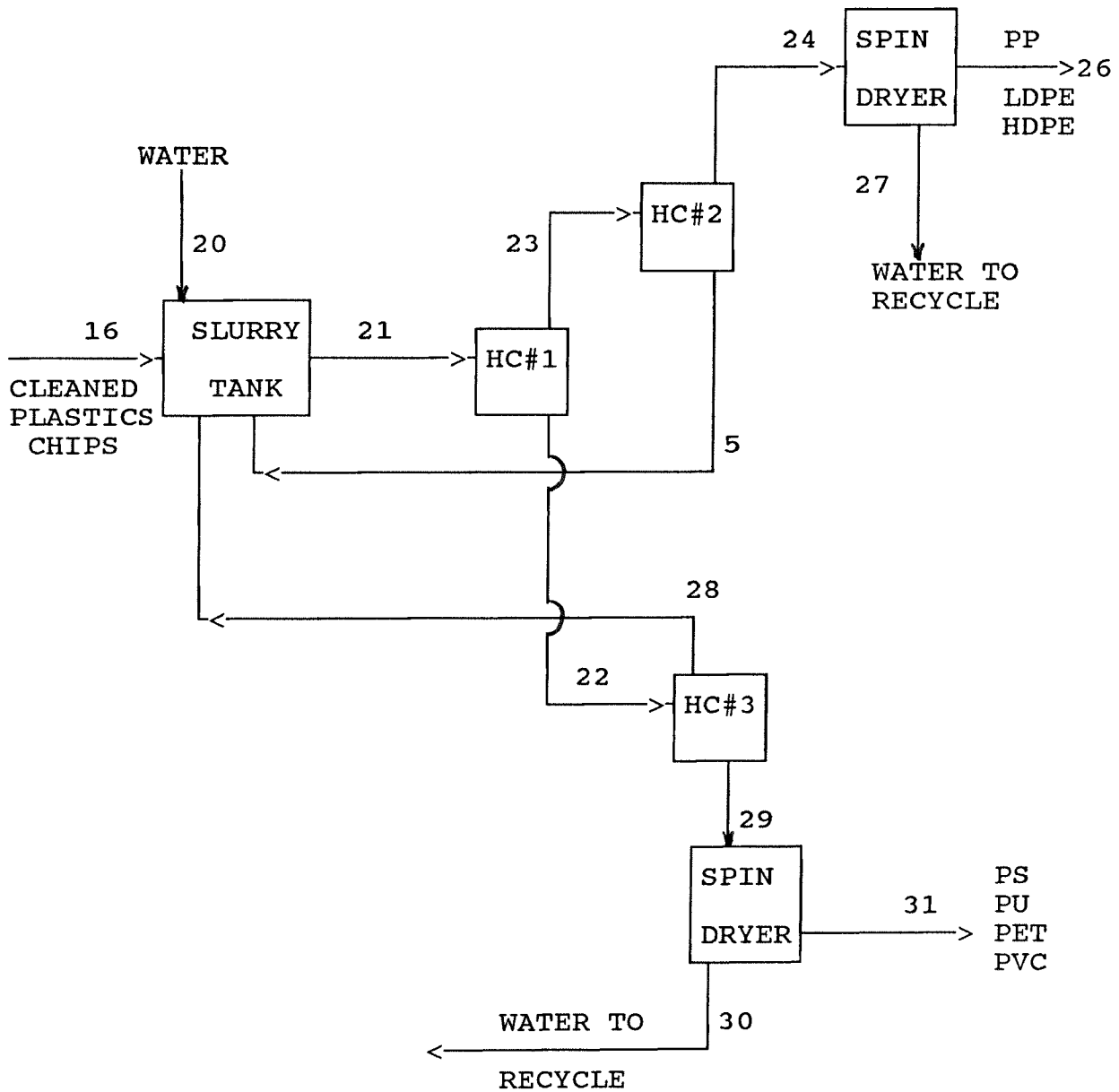

Table XXI. Material Balance for the Separation of Plastics
Denser than Water and Less Dense than Water.

STREAMS (lb/hr)						
COMP	20	21	22	23	24	25
LDPE	0	1211.25	1199.14	12.11	1187.15	11.99
PVC	0	923.80	9.24	914.56	0	9.24
HDPE	0	648.14	641.66	6.48	635.24	6.42
PP	0	824.73	816.48	8.25	808.32	8.16
PS	0	590.04	5.90	584.14	0	5.90
PU	0	369.27	3.69	365.58	0	3.69
PET	0	109.78	1.10	108.68	0	1.10
H2O	71815.69	71815.69	35907.85	35907.85	17953.9	17953.9
TOTAL	71815.69	76492.70	38585.06	37907.65	20584.4	18000.4

Table XXI. (cont.) STREAMS (lb/hr)

COMP	26	27	28	29	30	31
LDPE	1187.15	0	12.11	0	0	0
PVC	0	0	9.15	905.41	0	905.41
HDPE	635.24	0	6.48	0	0	0
PP	808.32	0	8.25	0	0	0
PS	0	0	5.84	578.30	0	578.30
PU	0	0	3.66	361.92	0	361.92
PET	0	0	1.09	107.64	0	107.64
H2O	0	17953.92	17953.92	17953.92	17953.9	0
TOTAL	2630.71	17953.92	18000.50	19907.14	17953.9	1953.27

UNIT VI: POLYSTYRENE (PS) SEPARATION

In this step of the process the mixture of heavy plastics PS, PU, PET, and PVC is suspended in a solution of density equal to 1.09. The separation is performed taking advantage of difference in densities among these components. Figure 10 shows a scheme of this separation.

The assumptions for the material balance are:

- a) Efficiency of hydrocyclone 4 = 99%
- b) Only PU and PS go in overflow stream in Hydrocyclone 4.
- c) All PS is completely separated in hydrocyclone 5.
- d) Efficiency hydrocyclone 6 = 100%
- e) Liquid split 50%-50%.

Table XXII presents the material balance indicating lb/hr of each stream.

Figure 10. Separation of Polystyrene (PS)

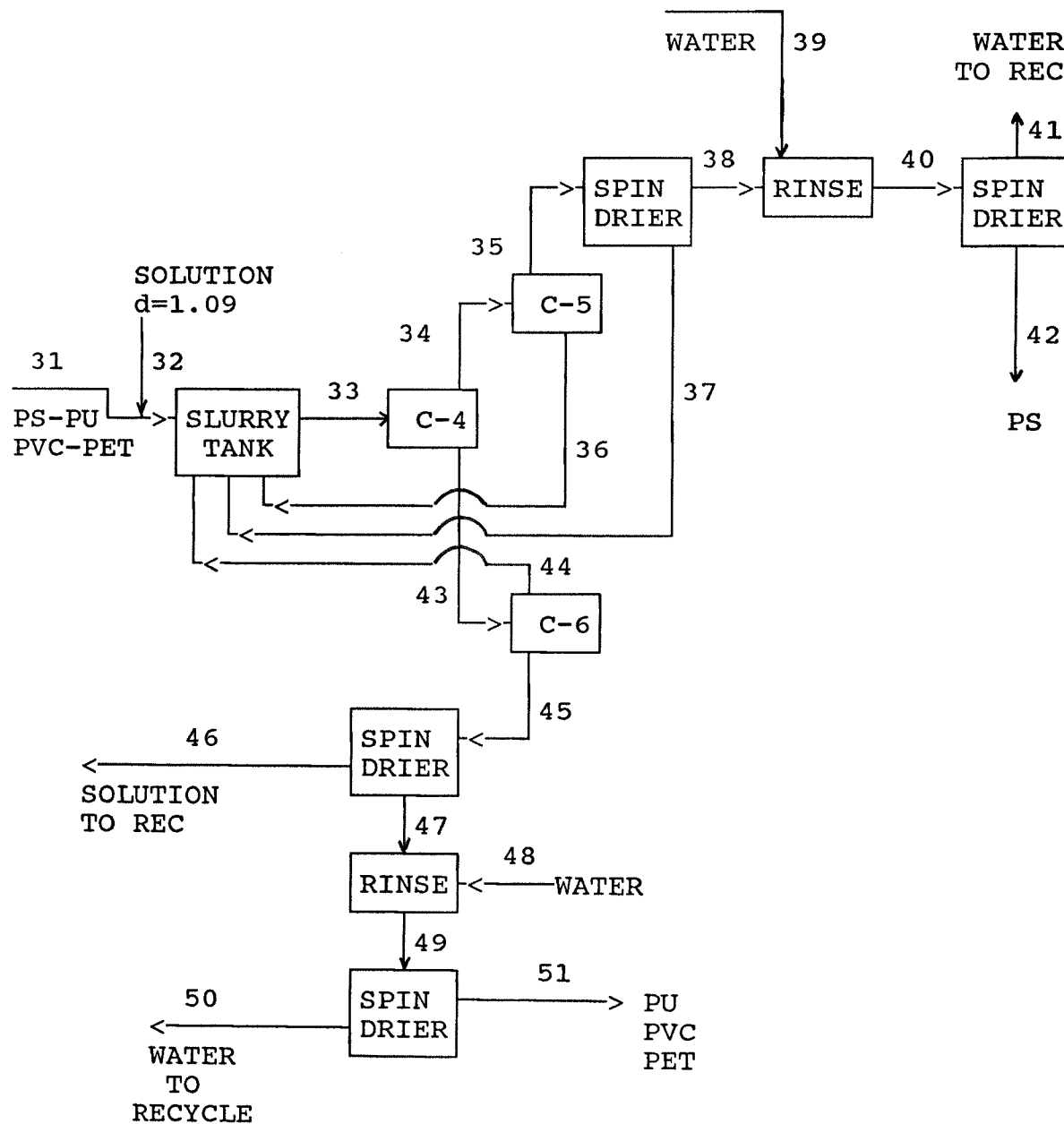

Component	Density
PS	1.05
PU	1.20
PET	1.37
PVC	1.38

Table XXII. Material Balance Polystyurene (PS) Separation.

STREAMS (lb/hr)					
COMP	32	33	34	35	36
PVC	0	905.41	0	0	0
PS	0	584.14	578.30	578.30	0
PU	0	365.58	3.66	0	3.66
PET	0	107.64	0	0	0
SOL. d=1.09	30601.23	30601.23	15300.61	7650.31	7650.31
TOTAL	30601.23	32564.50	15882.57	8228.61	7653.97

Table XXII. (cont.) STREAMS (lb/hr)

COMP	37	38	39	40	41
PVC	0	0	0	0	0
PS	0	578.30	0	578.30	0
PU	0	0	0	0	0
PET	0	0	0	0	0
SOL. d=1.09	7650.31	0	0	0	0
WATER	0	0	9060.03	9060.03	9060.03
TOTAL	7650.31	578.30	9060.03	9638.33	9060.03

Table XXII (cont.)

STREAMS (lb/hr)

COMP	42	43	44	45	46
PVC	0	905.41	0	905.41	0
PS	578.30	5.84	5.84	0	0
PU	0	361.92	0	361.92	0
PET	0	107.64	0	107.64	0
SOL. d=1.09	0	15300.53	7650.26	7650.26	7650.26
TOTAL	578.03	16681.34	7656.10	9025.23	7650.26

Table XXII (cont.)

STREAMS (lb/hr)

COMP	47	48	49	50	51
PVC	905.41	0	905.41	0	905.41
PS	0	0	0	0	0
PU	361.92	0	361.92	0	361.92
PET	107.64	0	107.64	0	107.64
SOL. d=1.09	0	0	0	0	0
WATER	0	21541.10	21541.10	21541.10	0
TOTAL	1374.97	21541.10	22916.06	21541.10	1374.97

UNIT VII: POLYURETHANE (PU) SEPARATION

PU is separated from PVC and PET by suspending their chips in a solution of density 1.30 and passing the mixture by a three-cyclon unit. Two streams are obtained: one stream contains PU chips (density less than 1.30) and the other stream carries PVC and PET chips (density greater than 1.30). Figure 11 presents the diagram of this step.

Results of the material balance based on the following assumptions appear in Table XXV .

- Assumptions:
- a) Efficiency hydrocyclone 7 = 99%
 - b) All PU is separated in hydrocyclone 8.
 - c) Efficiency hydrocyclone 9 = 99%

Figure 11. Separation of Polyurethane (PU)

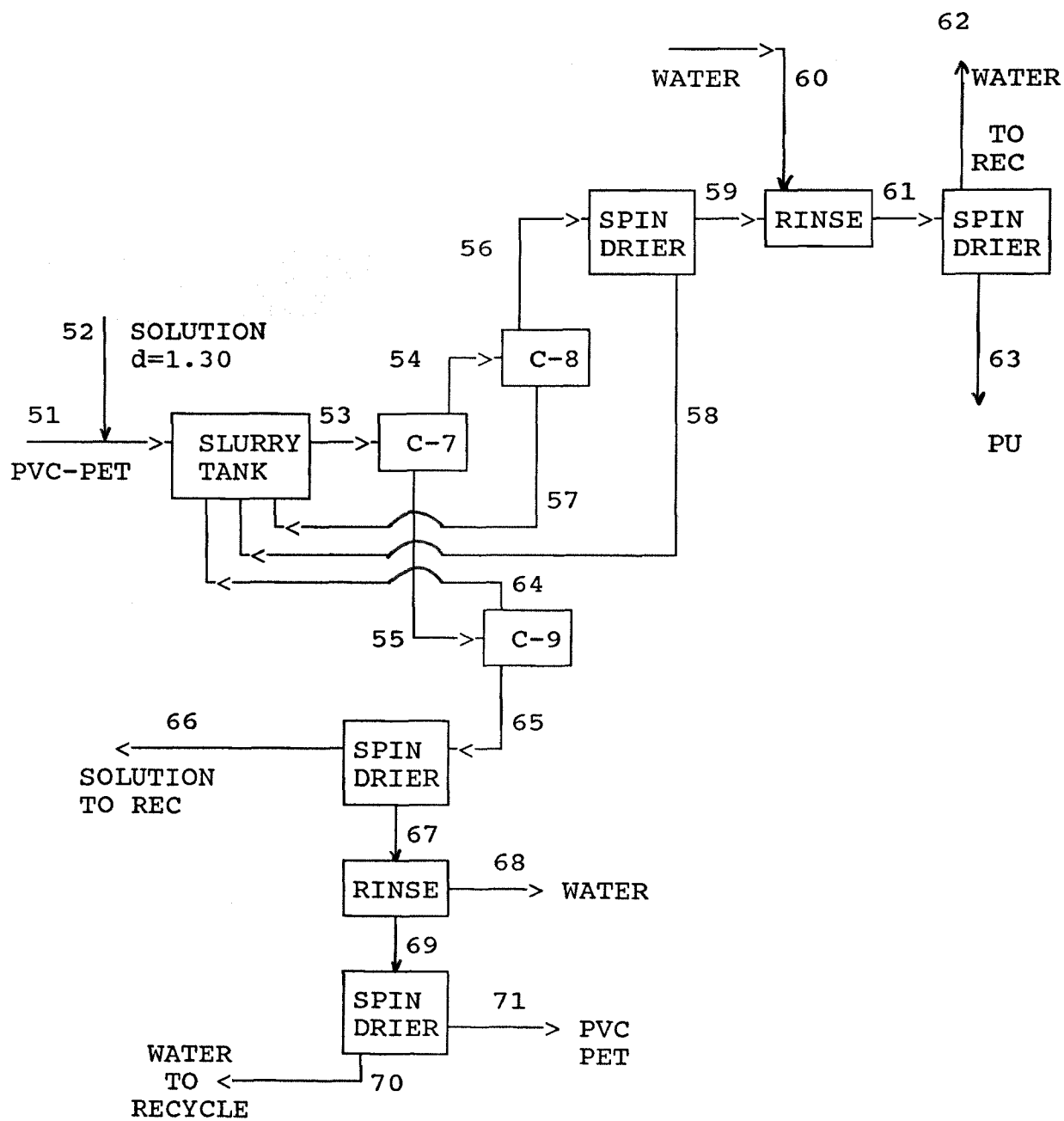

Component	Density
PU	1.20
PET	1.37
PVC	1.38

Table XXIII. Material Balance Polyurethane (PU) Separation.

STREAMS (lb/hr)

COMP	52	53	54	55	56
PVC	0	924.22	9.24	914.98	0
PU	0	369.27	365.58	3.69	361.92
PET	0	109.78	1.1	108.68	0
SOL. d=1.30	26124.43	26124.43	13062.21	13062.21	6531.11
TOTAL	30601.23	32554.50	15882.58	8228.61	7653.97

Table XXIII (cont.) STREAMS (lb/hr)

COMP	57	58	59	60	61
PVC	9.24	0	0	0	0
PU	3.66	0	361.92	0	361.92
PET	1.1	0	0	0	0
SOL. d=1.30	6531.11	6531.11	0	0	0
WATER	0	0	0	5670.08	5670.08
TOTAL	6545.11	6531.11	361.92	5670.08	6032.00

Table XXIII (cont.)

STREAMS (lb/hr)

COMP	62	63	64	65	66
PVC	0	0	9.14	905.41	0
PU	0	361.92	3.69	0	0
PET	0	0	1.1	107.64	0
SOL. d=1.09	0	0	6531.11	6531.11	6531.11
WATER	5670.08	0	0	0	0
TOTAL	5670.08	361.92	6545.04	7544.16	6531.11

Table XXIII (cont.)

COMP	67	68	69	70	71
PVC	905.41	0	905.41	0	905.41
PU	0	0	0	0	0
PET	107.64	0	107.64	0	107.64
SOL. d=1.09	0	0	0	0	0
WATER	0	15871.12	15871.12	15871.12	0
TOTAL	1013.05	15871.12	16884.17	15871.12	1013.05

UNIT VIII: PVC AND PET SEPARATION

The individual separation of PVC and PET is presented in Figure 12. A selective solvent with the particular characteristic of dissolving only one of the two components is used. The important fact of this separation is that one of the resin forms solution at certain temperature and the other is insoluble in the same solvent at the same condition of temperature.

The mass flow of the streams participating in this separation appears in Table XXIV. **

** The amount of solvent required to dissolve a component depends upon the plastic and the solvent used. Burrell (35) predicted solubility of commercial polymers suggesting about 10-20% of polymer concentration. Although experimental tests are necessary for optimizing the amount of solvent to achieve the solution of the resin, it is assumed 15% of solids concentration in the solvent-plastic mixture.

Figure 12. Separation of Polyvinyl Chloride (PVC) and Polyethylene Terephthalate (PET).

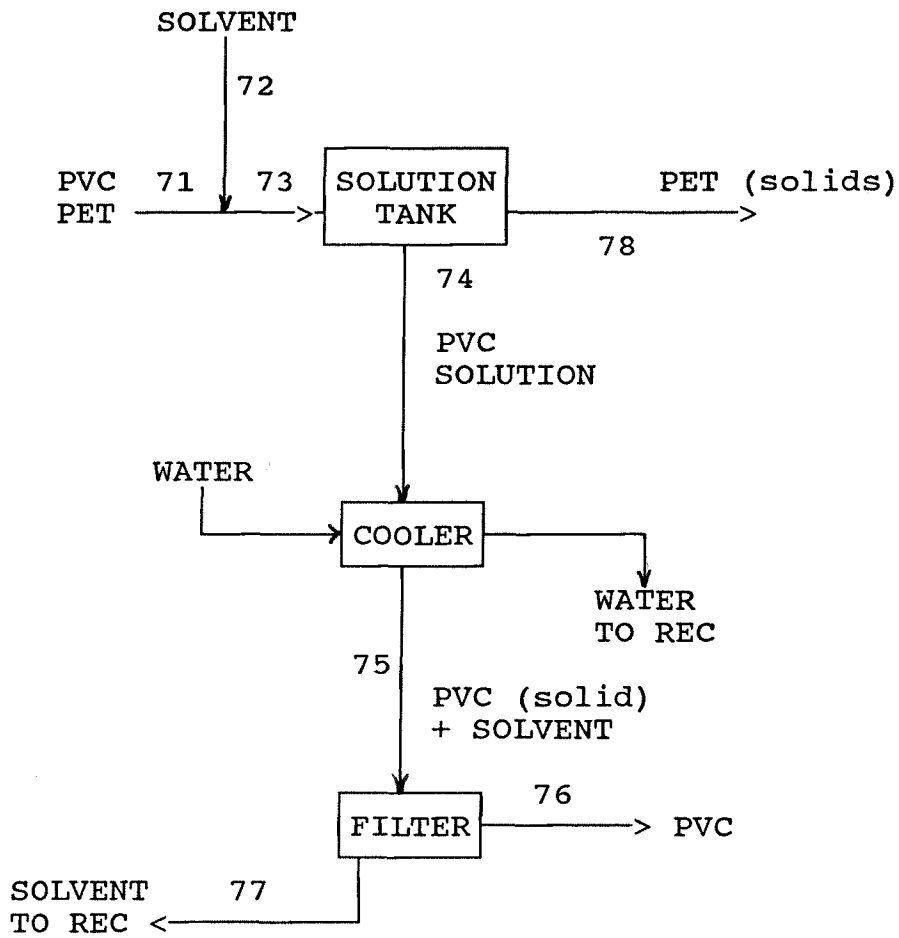

Table XXIV. Material Balance Polyvinyl Chloride (PVC) and Polyethylene Terephthalate (PET) Separation.

STREAMS (lb/hr)					
COMP	71	72	73	74	75
PVC	905.41	0	905.41	905.41	905.41
PET	107.64	0	107.64	0	0
SOLVENT	0	5740.62	5740.62	5740.62	5740.62
TOTAL	1013.05	5740.62	6753.67	6646.03	6646.03

Table XXIV. (cont)

Solids = 15%
Solvent = 85%

COMP	76	77	78
PVC	905.41	0	0
PET	0	0	107.64
SOLVENT	0	5740.62	0
TOTAL	905.41	5740.62	107.64

UNIT IX: LDPE, HDPE, AND PP SEPARATION

Similar to PVC and PET separation, a solvent is used to get individual plastic type based on the solubility difference that polyolefins exhibit when temperature is raised.

Figure 13 details the separation and the values of the material balance are contained in Table XXV.**

** 15% of plastic solids concentration is assumed to evaluate the amount of solvent required to dissolve the resin.

Figure 13. Separation of Low Density Polyethylene (LDPE), High Density Polyethylene (HDPE), and Polypropylene (PP).

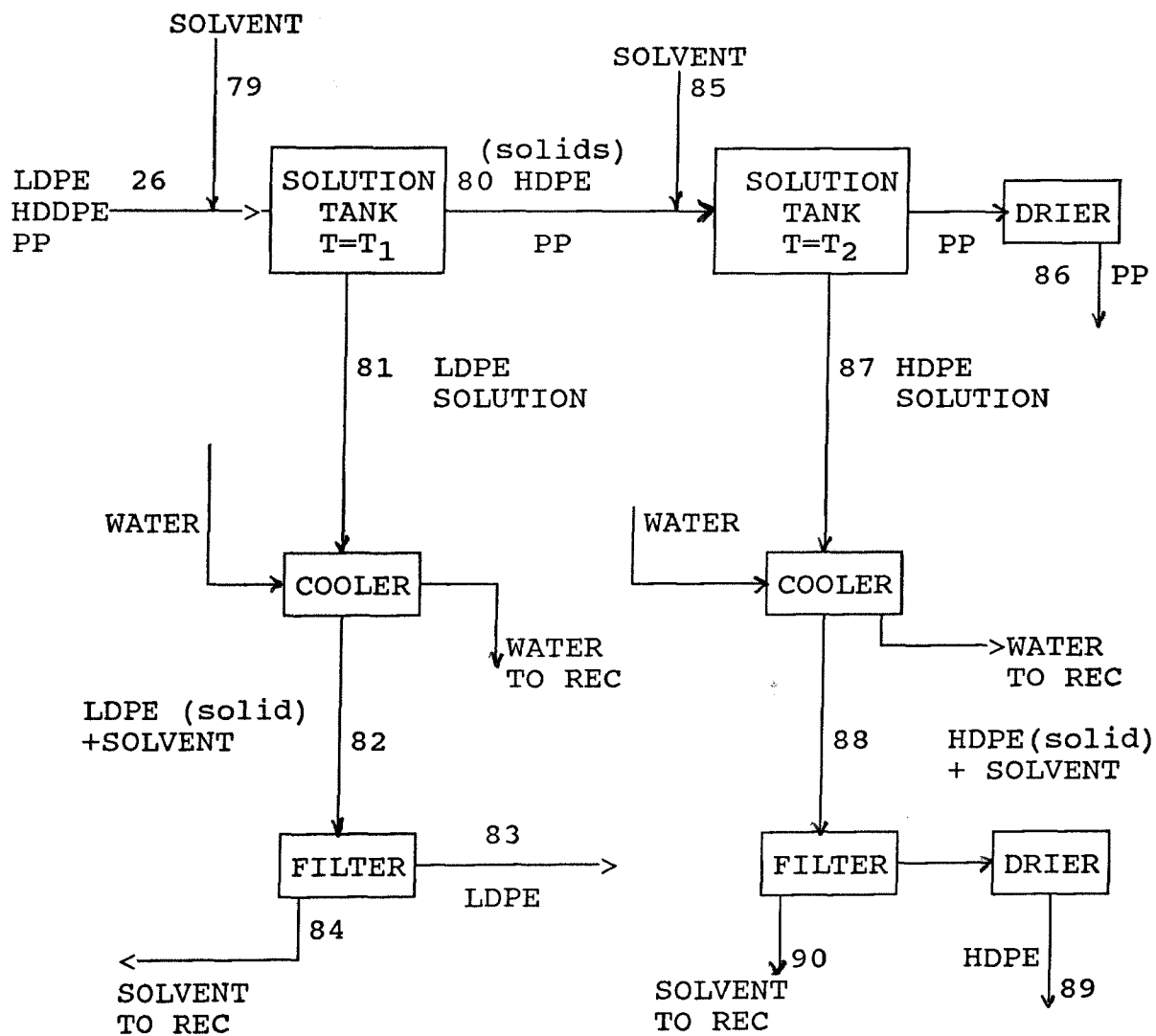

Table XXV. Material Balance low Density Polyethylene (LDPE), High Density Polyethylene (HDPE), and Polypropylene (PP) Separation.

		STREAMS (lb/hr)				
COMP		79	80	81	82	83
LDPE		0	0	1187.15	1187.15	1187.15
HDPE		0	635.24	0	0	0
PP		0	808.32	0	0	0
SOLVENT	14907.36	0	14907.36	14907.36	14907.36	0
TOTAL		14907.36	1443.56	16094.51	16094.51	1187.15

Solids = 15%
Solvent = 85%

Table XXV (cont.)

		STREAMS (lb/hr)						
		84	85	86	87	88	89	90
		0	0	0	0	0	0	0
		0	0	0	635.24	635.24	635.24	0
		0	0	808.32	0	0	0	0
	14907.36	8180.17	0	8180.17	8180.17	8180.17	0	8180.17
		14907.36	8180.17	808.32	8815.41	8815.41	635.24	8180.17

CONCLUSIONS

- 1- The proposed and discussed process for separating LDPE, HDPE, PVC, PP, PS, PU, and PET into generic resins from a postconsumer plastics mixture, represents an alternative for industrial application.
- 2- Due to the similarity in density values of polyolefins (HDPE, LDPE and PP), gravimetric methods are not recommended to achieve their separation.
- 3- The density values of PU and PS allow easy separation from the others by gravity.
- 4- PVC and PET which have similar density values, can be separated by dissolving one of these resins in a specific solvent.
- 5- The methods proposed for determining solubility of plastics in solvents only represents the initial aspect of a complex process for selecting the final solvent. Additional tests are necessary.
- 6- The use of the QUATTRO PRO spreadsheet to compute the material balance of the entire process allows easy and fast recalculation when some changes are introduced into the process. Some of the changes are:
 - a) capacity of the plant
 - b) composition of the feed stream
 - c) equipment efficiencies

RECOMMENDATIONS

Some recommendations can be given based on the analysis of different recycling processes in comparison with this particular proposed process.

- Effectiveness of the plastic recycling process depends basically on a good separation of plastics types from collected waste materials.
- It is important to separate all aluminum before granulation to avoid further use of an electrostatic separator.
- Separation of PET bottles in clear and green color increases their value.
- When solvents are used to dissolve a particular plastic, experimental tests should be performed to determine the best solvent, temperature, agitation, and amount of solvent required to produce the solution.

- Another alternative to separate LDPE, HDPE, and PP in individual resins could be first separating LDPE from HDPE and PP using a solvent, and then isolating HDPE from PP based on their difference in density.

APPENDIX 1

Results of material balances using QUATTRO PRO*

* QUATTRO PRO is an electronic spreadsheet introduced at the end of 1987 by Borland International.

Material Balance using QUATTRO PRO, case 1:

Capacity	=	6493.506	lb/hr	
Seven major plastics	=	5000.000	lb/hr	(77%)
Others	=	1493.506	lb/hr	(23%)

MATERIAL BALANCE SEPARATION OF MAJOR PLASTICS

***** COMP Name	***** FEED lb/hr	***** FEED Wt. %	STREAMS=>	lb/hr 1	Wt. % 1
LDPE	1187.15	18.28		1187.15	18.28
PVC	928.53	14.30		928.53	14.30
HDPE	905.80	13.95		905.80	13.95
PP	808.32	12.45		808.32	12.45
PS	578.30	8.91		578.30	8.91
PU	361.92	5.57		361.92	5.57
PET	212.47	3.27		212.47	3.27
EVA	8.75	0.13		8.75	0.13
Paper	7.30	0.11		7.30	0.11
Al	1.46	0.02		1.46	0.02
Sub-total	5000.00	77.00		5000.00	77.00
Others	1493.51	23.00		1493.51	23.00
Total	6493.51	100.00		6493.51	100.00
Factor, % (waste)	23.00		Capacity	6493.51	

LDPE == Low Density PolyEthylene
PVC == PolyVinyl Chloride
HDPE == High Density PolyEthylene
PP == PolyPropylene
PS == PolyStyrene
PU == PolyUrethane
PET == PolyEthylene Terephthalate
Al == Aluminum
EVA == Ethylene Vinyl Acetate

	lb/hr 2	lb/hr 3	SEPARAT. %	lb/hr 4	lb/hr 5
LDPE	0.00	1187.15	0.00	0.00	1187.15
PVC	0.00	928.53	2.49	23.12	905.41
HDPE	0.00	905.80	29.87	270.56	635.24
PP	0.00	808.32	0.00	0.00	808.32
PS	0.00	578.30	0.00	0.00	578.30
PU	0.00	361.92	0.00	0.00	361.92
PET	0.00	212.47	49.34	104.83	107.64
EVA	0.00	8.75	50.00	4.38	4.38
Paper	0.00	7.30	50.00	3.65	3.65
Al	0.00	1.46	100.00	1.46	0.00
Others	1493.51				
Total=	1493.51	5000.00		408.00	4592.00
Solids=		5000.00		408.00	4592.00

	lb/hr 6	lb/hr 7	lb/hr 8	lb/hr 9	lb/hr 10
LDPE	0.00	0.00	0.00	1187.15	0.00
PVC	0.00	23.12	0.00	905.41	0.00
HDPE	0.00	0.00	270.56	635.24	0.00
PP	0.00	0.00	0.00	808.32	0.00
PS	0.00	0.00	0.00	578.30	0.00
PU	0.00	0.00	0.00	361.92	0.00
PET	104.83	0.00	0.00	107.64	0.00
EVA	4.38 *			4.38	0.00
Paper	3.65 *			7.30	5.48
Al	1.46 *				

Total=	114.32	23.12	270.56	4595.65	5.48
Solids=	114.32	23.12	270.56	4595.65	5.48

Efficiency AC-1==>
Total paper sep.=>
25% paper fed A-1

*Separated in streams 6,7, and 8.

	lb/hr 11	lb/hr 12	lb/hr 13	lb/hr 14	lb/hr 15
LDPE	0.00	0.00	1187.15	0.00	1187.15
PVC	0.00	0.00	905.41	0.00	905.41
HDPE	0.00	0.00	635.24	0.00	635.24
PP	0.00	0.00	808.32	0.00	808.32
PS	0.00	0.00	578.30	0.00	578.30
PU	0.00	0.00	361.92	0.00	361.92
PET	0.00	0.00	107.64	0.00	107.64
EVA	0.00	0.00	4.38	0.00	4.38
Paper	3.65	1.83	1.83	0.00	1.83

Det.Sol. 71912.77 71912.77

Total= 3.65 1.83 4590.18 71912.77 76502.95
Solids= 3.65 1.83 4590.18 0.00 4590.18

0.75
0.50
goes with plastics 0.25
Solids 6%

split==>

	lb/hr 16	lb/hr 17	lb/hr 18	lb/hr 19	lb/hr 20
LDPE	1187.15	0.00	0.00	0.00	0.00
PVC	905.41	0.00	0.00	0.00	0.00
HDPE	635.24	0.00	0.00	0.00	0.00
PP	808.32	0.00	0.00	0.00	0.00
PS	578.30	0.00	0.00	0.00	0.00
PU	361.92	0.00	0.00	0.00	0.00
PET	107.64	0.00	0.00	0.00	0.00
EVA	0.00	4.38	4.38	0.00	
Paper	0.00	1.83	1.83	0.00	
Det.Sol. WATER	0.00	71912.77	0.00	71912.77	71815.64
Total=	4583.98	71918.97	6.20	71912.77	71815.64
Solids=	4583.98	6.20	6.20	0.00	0.00

=====> 0.06

=====> 0.50

	(DENSITY = 1.00) **** HYDROCYCLONE #1 ****			(DENSITY = 1.00) *HYDROCYCLONE #2*	
	FEED	UP	DOWN	UP	DOWN (REC)
	lb/hr	lb/hr	lb/hr	lb/hr	lb/hr
	21	22	23	24	25
LDPE	1211.25	1199.14	12.11	1187.15	11.99
PVC	923.79	9.24	914.55	0.00	9.24
HDPE	648.13	641.65	6.48	635.24	6.42
PP	824.73	816.48	8.25	808.32	8.16
PS	590.04	5.90	584.14	0.00	5.90
PU	369.27	3.69	365.57	0.00	3.69
PET	109.82	1.10	108.72	0.00	1.10
WATER	71815.64	35907.82	35907.82	17953.91	17953.91
Total=	76492.67	38585.02	37907.65	20584.61	18000.41
Solids=	4677.03	2677.20	1999.83	2630.70	46.50
Percent recycled each component= 2%==>				0.02	
Hydrocyc. efficiency = 99%==>				0.99	

	(DENSITY = 1.00)				
	* HYDROCYCLONE #3*				
			DOWN	UP	
	lb/hr	lb/hr	lb/hr	lb/hr	lb/hr
	26	27	28	29	30
LDPE	1187.15	0.00	12.11	0.00	0.00
PVC	0.00	0.00	9.15	905.41	0.00
HDPE	635.24	0.00	6.48	0.00	0.00
PP	808.32	0.00	8.25	0.00	0.00
PS	0.00	0.00	5.84	578.30	0.00
PU	0.00	0.00	3.66	361.92	0.00
PET	0.00	0.00	1.09	107.64	0.00
WATER	0.00	17953.91	17953.91	17953.91	17953.91
Total=	2630.70	17953.91	18000.48	19907.17	17953.91
Solids=	2630.70	0.00	46.57	1953.26	0.00

	(DENSITY = 1.09) *HYDROCYCLONE #4*					HYDROC #5
	FEED					
	lb/hr	lb/hr	lb/hr	lb/hr	lb/hr	
	31	32	33	34	35	
LDPE	0.00	0.00	0.00	0.00	0.00	0.00
PVC	905.41	0.00	905.41	0.00	0.00	0.00
HDPE	0.00	0.00	0.00	0.00	0.00	0.00
PP	0.00	0.00	0.00	0.00	0.00	0.00
PS	578.30	0.00	584.14	578.30	578.30	578.30
PU	361.92	0.00	365.57	3.66	0.00	0.00
PET	107.64	0.00	107.64	0.00	0.00	0.00
 Solution d=1.09	 0.00	 30601.08	 30601.08	 15300.54	 7650.27	
 Total=	 1953.26	 30601.08	 32563.83	 15882.49	 8228.57	
Solids=	1953.26	0.00	1962.76	581.95	578.30	

PU SEPARATION = 99%
PS SEPARATION = 99%

	DOWN (REC)				
	lb/hr	lb/hr	lb/hr	lb/hr	lb/hr
	36	37	38	39	40
LDPE	0.00	0.00	0.00	0.00	0.00
PVC	0.00	0.00	0.00	0.00	0.00
HDPE	0.00	0.00	0.00	0.00	0.00
PP	0.00	0.00	0.00	0.00	0.00
PS	0.00	0.00	578.30	0.00	578.30
PU	3.66	0.00	0.00	0.00	0.00
PET	0.00	0.00	0.00	0.00	0.00
WATER			0.00	9060.00	9060.00
Solution	7650.27	7650.27	0.00	0.00	0.00
d=1.09					
Total=	7653.92	7650.27	578.30	9060.00	9638.30
Solids=	3.66	0.00	578.30	0.00	578.30

	lb/hr	lb/hr	HC-6 lb/hr	HC-6 lb/hr	HC-6 lb/hr
	41	42	43	44	45
LDPE	0.00	0.00	0.00	0.00	0.00
PVC	0.00	0.00	905.41	0.00	905.41
HDPE	0.00	0.00	0.00	0.00	0.00
PP	0.00	0.00	0.00	0.00	0.00
PS	0.00	578.30	5.84	5.84	0.00
PU	0.00	0.00	361.92	0.00	361.92
PET	0.00	0.00	107.64	0.00	107.64
WATER	9060.00	0.00	0.00		
Solution d=1.09	0.00	0.00	15300.54	7650.27	7650.27
Total=	9060.00	578.30	16681.34	7656.11	9025.23
Solids=	0.00	578.30	1380.80	5.84	1374.96

	lb/hr 46	lb/hr 47	lb/hr 48	lb/hr 49	lb/hr 50
LDPE	0.00	0.00	0.00	0.00	0.00
PVC	0.00	905.41	0.00	905.41	0.00
HDPE	0.00	0.00	0.00	0.00	0.00
PP	0.00	0.00	0.00	0.00	0.00
PS	0.00	0.00	0.00	0.00	0.00
PU	0.00	361.92	0.00	361.92	0.00
PET	0.00	107.64	0.00	107.64	0.00
					0.00
WATER			21541.07	21541.07	21541.07
Solution d=1.30	7650.27	0.00	0.00	0.00	
Total=	7650.27	1374.96	21541.07	22916.04	21541.07
Solids=	0.00	1374.96	0.00	1374.96	0.00

(DENSITY = 1.30)
 *** HYDROCYCLONE #7 ***

	lb/hr 51	lb/hr 52	lb/hr 53	lb/hr 54	lb/hr 55
LDPE	0.00	0.00	0.00	0.00	0.00
PVC	905.41	0.00	923.79	9.24	914.55
HDPE	0.00	0.00	0.00	0.00	0.00
PP	0.00	0.00	0.00	0.00	0.00
PS	0.00	0.00	0.00	0.00	0.00
PU	361.92	0.00	369.27	365.57	3.69
PET	107.64	0.00	109.82	1.10	108.72
WATER Solution d=1.30	0.00	26124.28	26124.28	13062.14	13062.14
Total=	1374.96	26124.28	27527.16	13438.05	14089.11
Solids=	1374.96	0.00	1402.88	375.91	1026.97
Solids in slurry=>		0.05			

(DENSITY = 1.30)
 HYDROCYCLONE #8

	lb/hr 56	lb/hr 57	lb/hr 58	lb/hr 59	lb/hr 60
LDPE	0.00	0.00	0.00	0.00	0.00
PVC	0.00	9.24	0.00	0.00	0.00
HDPE	0.00	0.00	0.00	0.00	0.00
PP	0.00	0.00	0.00	0.00	0.00
PS	0.00	0.00	0.00	0.00	0.00
PU	361.92	3.66	0.00	361.92	0.00
PET	0.00	1.10	0.00	0.00	0.00
WATER					5670.06
Solution d=1.30	6531.07	6531.07	6531.07	0.00	0.00
Total=	6892.99	6545.06	6531.07	361.92	5670.06
Solids=	361.92	13.99	0.00	361.92	0.00

	lb/hr 61	lb/hr 62	lb/hr 63	lb/hr 64	lb/hr 65
LDPE	0.00	0.00	0.00	0.00	0.00
PVC	0.00	0.00	0.00	9.15	905.41
HDPE	0.00	0.00	0.00	0.00	0.00
PP	0.00	0.00	0.00	0.00	0.00
PS	0.00	0.00	0.00	0.00	0.00
PU	361.92	0.00	361.92	3.69	0.00
PET	0.00	0.00	0.00	1.09	107.64
WATER	5670.06	5670.06	0.00		
Solution d=1.30	0.00	0.00		6531.07	6531.07
Total=	6031.98	5670.06	361.92	6545.00	7544.11
Solids=	361.92	0.00	361.92	13.93	1013.04

	lb/hr 66	lb/hr 67	lb/hr 68	lb/hr 69	lb/hr 70
LDPE	0.00	0.00	0.00	0.00	0.00
PVC	0.00	905.41	0.00	905.41	0.00
HDPE	0.00	0.00	0.00	0.00	0.00
PP	0.00	0.00	0.00	0.00	0.00
PS	0.00	0.00	0.00	0.00	0.00
PU	0.00	0.00	0.00	0.00	0.00
PET	0.00	107.64	0.00	107.64	0.00
WATER Solution d=1.30	6531.07	0.00	15871.01	15871.01	15871.01
Total=	6531.07	1013.04	15871.01	16884.06	15871.01
Solids=	0.00	1013.04	0.00	1013.04	0.00

LDPE,HDPE,PP SEPARATION BY SOLVENT

	lb/hr 76	lb/hr 77	lb/hr 78	lb/hr 79	lb/hr 80
LDPE	0.00	0.00	0.00	0.00	0.00
PVC	905.41	0.00	0.00	0.00	0.00
HDPE	0.00	0.00	0.00	0.00	635.24
PP	0.00	0.00	0.00	0.00	808.32
PS	0.00	0.00	0.00	0.00	0.00
PU	0.00	0.00	0.00	0.00	0.00
PET	0.00	0.00	107.64	0.00	0.00
SOLVENT	0.00	5740.58	0.00	14907.29	0.00
Total=	905.41	5740.58	107.64	14907.29	1443.55
Solids=	905.41	0.00	107.64	0.00	1443.55

	lb/hr 86	lb/hr 87	lb/hr 88	lb/hr 89	lb/hr 90
LDPE	0.00	0.00	0.00	0.00	0.00
PVC	0.00	0.00	0.00	0.00	0.00
HDPE	0.00	635.24	635.24	635.24	0.00
PP	808.32	0.00	0.00	0.00	0.00
PS	0.00	0.00	0.00	0.00	0.00
PU	0.00	0.00	0.00	0.00	0.00
PET	0.00	0.00	0.00	0.00	0.00
SOLVENT	0.00	8180.13	8180.13	0.00	8180.13
Total=	808.32	8815.37	8815.37	635.24	8180.13
Solids=	808.32	635.24	635.24	635.24	0.00

Material Balance using QUATTRO PRO, case 2:

Capacity = 9000.000 lb/hr

Seven major plastics : 77%

Others : 23%

MATERIAL BALANCE SEPARATION OF MAJOR PLASTICS

***** COMP Name	***** FEED lb/hr	***** FEED Wt. %	STREAMS=> lb/hr 1	Wt. % 1
LDPE	1187.15	18.28	1645.39	18.28
PVC	928.53	14.30	1286.94	14.30
HDPE	905.80	13.95	1255.44	13.95
PP	808.32	12.45	1120.33	12.45
PS	578.30	8.91	801.52	8.91
PU	361.92	5.57	501.62	5.57
PET	212.47	3.27	294.48	3.27
EVA	8.75	0.13	12.13	0.13
Paper	7.30	0.11	10.12	0.11
Al	1.46	0.02	2.02	0.02
Sub-total	5000.00	77.00	6930.00	77.00
Others	1493.51	23.00	2070.00	23.00
Total	6493.51	100.00	9000.00	100.00
Factor, % (waste)	23.00		Capacity 9000.00	

LDPE == Low Density PolyEthylene
 PVC == PolyVinyl Chloride
 HDPE == High Density PolyEthylene
 PP == PolyPropylene
 PS == PolyStyrene
 PU == PolyUrethane
 PET == PolyEthylene Terephthalate
 Al == Aluminum
 EVA == Ethylene Vinyl Acetate

	lb/hr 2	lb/hr 3	SEPARAT. %	lb/hr 4	lb/hr 5
LDPE	0.00	1645.39	0.00	0.00	1645.39
PVC	0.00	1286.94	2.49	32.04	1254.90
HDPE	0.00	1255.44	29.87	375.00	880.44
PP	0.00	1120.33	0.00	0.00	1120.33
PS	0.00	801.52	0.00	0.00	801.52
PU	0.00	501.62	0.00	0.00	501.62
PET	0.00	294.48	49.34	145.30	149.19
EVA	0.00	12.13	50.00	6.06	6.06
Paper	0.00	10.12	50.00	5.06	5.06
Al	0.00	2.02	100.00	2.02	0.00

Others 2070.00

Total=	2070.00	6930.00		565.49	6364.51
Solids=		6930.00		565.49	6364.51

	lb/hr 6	lb/hr 7	lb/hr 8	lb/hr 9	lb/hr 10
LDPE	0.00	0.00	0.00	1645.39	0.00
PVC	0.00	32.04	0.00	1254.90	0.00
HDPE	0.00	0.00	375.00	880.44	0.00
PP	0.00	0.00	0.00	1120.33	0.00
PS	0.00	0.00	0.00	801.52	0.00
PU	0.00	0.00	0.00	501.62	0.00
PET	145.30	0.00	0.00	149.19	0.00
EVA	6.06 *			6.06	0.00
Paper	5.06 *			10.12	7.59
Al	2.02 *				

Total=	158.44	32.04	375.00	6369.57	7.59
Solids=	158.44	32.04	375.00	6369.57	7.59

Efficiency AC-1==>
Total paper sep.=>
25% paper fed A-1

*Separated in streams 6,7, and 8.

	lb/hr 11	lb/hr 12	lb/hr 13	lb/hr 14	lb/hr 15
LDPE	0.00	0.00	1645.39	0.00	1645.39
PVC	0.00	0.00	1254.90	0.00	1254.90
HDPE	0.00	0.00	880.44	0.00	880.44
PP	0.00	0.00	1120.33	0.00	1120.33
PS	0.00	0.00	801.52	0.00	801.52
PU	0.00	0.00	501.62	0.00	501.62
PET	0.00	0.00	149.19	0.00	149.19
EVA	0.00	0.00	6.06	0.00	6.06
Paper	5.06	2.53	2.53	0.00	2.53
Det.Sol.				99671.05	99671.05
Total=	5.06	2.53	6361.98	99671.05	106033.03
Solids=	5.06	2.53	6361.98	0.00	6361.98
	0.75				
	0.50				Solids 6%
goes with plastics			0.25		
					split==>

	lb/hr 16	lb/hr 17	lb/hr 18	lb/hr 19	lb/hr 20
LDPE	1645.39	0.00	0.00	0.00	0.00
PVC	1254.90	0.00	0.00	0.00	0.00
HDPE	880.44	0.00	0.00	0.00	0.00
PP	1120.33	0.00	0.00	0.00	0.00
PS	801.52	0.00	0.00	0.00	0.00
PU	501.62	0.00	0.00	0.00	0.00
PET	149.19	0.00	0.00	0.00	0.00
EVA	0.00	6.06	6.06	0.00	
Paper	0.00	2.53	2.53	0.00	
Det.Sol. WATER	0.00	99671.05	0.00	99671.05	99536.42
Total=	6353.39	99679.64	8.59	99671.05	99536.42
Solids=	6353.39	8.59	8.59	0.00	0.00

=====> 0.06

=====> 0.50

	(DENSITY = 1.00) **** HYDROCYCLONE #1 ****			(DENSITY = 1.00) *HYDROCYCLONE #2*	
	FEED	UP	DOWN	UP	DOWN(REC)
	lb/hr	lb/hr	lb/hr	lb/hr	lb/hr
	21	22	23	24	25
LDPE	1678.79	1662.00	16.79	1645.38	16.62
PVC	1280.37	12.80	1267.57	0.00	12.80
HDPE	898.31	889.33	8.98	880.44	8.89
PP	1143.07	1131.64	11.43	1120.33	11.32
PS	817.79	8.18	809.62	0.00	8.18
PU	511.80	5.12	506.69	0.00	5.12
PET	152.21	1.52	150.69	0.00	1.52

WATER	99536.42	49768.21	49768.21	24884.11	24884.11
-------	----------	----------	----------	----------	----------

Total=	106018.78	53478.81	52539.98	28530.25	24948.56
Solids=	6482.36	3710.60	2771.76	3646.15	64.45

Percent recycled each component= 2%==> 0.02

Hydrocyc. efficiency = 99%==> 0.99

	(DENSITY = 1.00)				
	* HYDROCYCLONE #3*				
	lb/hr	lb/hr	DOWN	UP	lb/hr
	26	27	28	29	30
LDPE	1645.38	0.00	16.79	0.00	0.00
PVC	0.00	0.00	12.68	1254.89	0.00
HDPE	880.44	0.00	8.98	0.00	0.00
PP	1120.33	0.00	11.43	0.00	0.00
PS	0.00	0.00	8.10	801.52	0.00
PU	0.00	0.00	5.07	501.62	0.00
PET	0.00	0.00	1.51	149.18	0.00
WATER	0.00	24884.11	24884.11	24884.11	24884.11

Total=	3646.15	24884.11	24948.65	27591.32	24884.11
Solids=	3646.15	0.00	64.55	2707.22	0.00

	(DENSITY = 1.09)				
	HYDROCYCLONE #4				HYDROC #5
	FEED				
	lb/hr	lb/hr	lb/hr	lb/hr	lb/hr
	31	32	33	34	35
LDPE	0.00	0.00	0.00	0.00	0.00
PVC	1254.89	0.00	1254.89	0.00	0.00
HDPE	0.00	0.00	0.00	0.00	0.00
PP	0.00	0.00	0.00	0.00	0.00
PS	801.52	0.00	809.62	801.52	801.52
PU	501.62	0.00	506.69	5.07	0.00
PET	149.18	0.00	149.18	0.00	0.00

Solution					
d=1.09	0.00	42413.07	42413.07	21206.53	10603.27

Total=	2707.22	42413.07	45133.45	22013.12	11404.79
Solids=	2707.22	0.00	2720.38	806.59	801.52

PU SEPARATION = 99%
PS SEPARATION = 99%

	DOWN (REC)				
	lb/hr	lb/hr	lb/hr	lb/hr	lb/hr
	36	37	38	39	40
LDPE	0.00	0.00	0.00	0.00	0.00
PVC	0.00	0.00	0.00	0.00	0.00
HDPE	0.00	0.00	0.00	0.00	0.00
PP	0.00	0.00	0.00	0.00	0.00
PS	0.00	0.00	801.52	0.00	801.52
PU	5.07	0.00	0.00	0.00	0.00
PET	0.00	0.00	0.00	0.00	0.00
WATER			0.00	12557.16	12557.16
Solution	10603.27	10603.27	0.00	0.00	0.00
d=1.09					
Total=	10608.33	10603.27	801.52	12557.16	13358.68
Solids=	5.07	0.00	801.52	0.00	801.52

			HC-6	HC-6	HC-6
	lb/hr	lb/hr	lb/hr	lb/hr	lb/hr
	41	42	43	44	45
LDPE	0.00	0.00	0.00	0.00	0.00
PVC	0.00	0.00	1254.89	0.00	1254.89
HDPE	0.00	0.00	0.00	0.00	0.00
PP	0.00	0.00	0.00	0.00	0.00
PS	0.00	801.52	8.10	8.10	0.00
PU	0.00	0.00	501.62	0.00	501.62
PET	0.00	0.00	149.18	0.00	149.18
WATER	12557.16	0.00	0.00		
Solution d=1.09	0.00	0.00	21206.53	10603.27	10603.27
Total=	12557.16	801.52	23120.33	10611.36	12508.96
Solids=	0.00	801.52	1913.79	8.10	1905.70

	lb/hr 46	lb/hr 47	lb/hr 48	lb/hr 49	lb/hr 50
LDPE	0.00	0.00	0.00	0.00	0.00
PVC	0.00	1254.89	0.00	1254.89	0.00
HDPE	0.00	0.00	0.00	0.00	0.00
PP	0.00	0.00	0.00	0.00	0.00
PS	0.00	0.00	0.00	0.00	0.00
PU	0.00	501.62	0.00	501.62	0.00
PET	0.00	149.18	0.00	149.18	0.00
					0.00
WATER			29855.91	29855.91	29855.91
Solution d=1.30	10603.27	0.00	0.00	0.00	
Total=	10603.27	1905.70	29855.91	31761.61	29855.91
Solids=	0.00	1905.70	0.00	1905.70	0.00

(DENSITY = 1.30)
 *** HYDROCYCLONE #7 ***

	lb/hr 51	lb/hr 52	lb/hr 53	lb/hr 54	lb/hr 55
LDPE	0.00	0.00	0.00	0.00	0.00
PVC	1254.89	0.00	1280.37	12.80	1267.57
HDPE	0.00	0.00	0.00	0.00	0.00
PP	0.00	0.00	0.00	0.00	0.00
PS	0.00	0.00	0.00	0.00	0.00
PU	501.62	0.00	511.80	506.69	5.12
PET	149.18	0.00	152.21	1.52	150.69
WATER Solution d=1.30	0.00	36208.23	36208.23	18104.12	18104.12
Total=	1905.70	36208.23	38152.62	18625.13	19527.50
Solids=	1905.70	0.00	1944.39	521.01	1423.38
Solids in slurry=>		0.05			

(DENSITY = 1.30)
 HYDROCYCLONE #8

	lb/hr 56	lb/hr 57	lb/hr 58	lb/hr 59	lb/hr 60
LDPE	0.00	0.00	0.00	0.00	0.00
PVC	0.00	12.80	0.00	0.00	0.00
HDPE	0.00	0.00	0.00	0.00	0.00
PP	0.00	0.00	0.00	0.00	0.00
PS	0.00	0.00	0.00	0.00	0.00
PU	501.62	5.07	0.00	501.62	0.00
PET	0.00	1.52	0.00	0.00	0.00
WATER					7858.70
Solution d=1.30	9052.06	9052.06	9052.06	0.00	0.00
Total=	9553.68	9071.45	9052.06	501.62	7858.70
Solids=	501.62	19.39	0.00	501.62	0.00

	lb/hr 61	lb/hr 62	lb/hr 63	lb/hr 64	lb/hr 65
LDPE	0.00	0.00	0.00	0.00	0.00
PVC	0.00	0.00	0.00	12.68	1254.89
HDPE	0.00	0.00	0.00	0.00	0.00
PP	0.00	0.00	0.00	0.00	0.00
PS	0.00	0.00	0.00	0.00	0.00
PU	501.62	0.00	501.62	5.12	0.00
PET	0.00	0.00	0.00	1.51	149.18
WATER	7858.70	7858.70	0.00		
Solution d=1.30	0.00	0.00		9052.06	9052.06
Total=	8360.32	7858.70	501.62	9071.36	10456.14
Solids=	501.62	0.00	501.62	19.30	1404.08

	lb/hr 71	lb/hr 72	lb/hr 73	lb/hr 74	lb/hr 75
LDPE	0.00	0.00	0.00	0.00	0.00
PVC	1254.89	0.00	1254.89	1254.89	1254.89
HDPE	0.00	0.00	0.00	0.00	0.00
PP	0.00	0.00	0.00	0.00	0.00
PS	0.00	0.00	0.00	0.00	0.00
PU	0.00	0.00	0.00	0.00	0.00
PET	149.18	0.00	149.18	0.00	0.00
WATER	0.00				
SOLVENT		7956.44	7956.44	7956.44	7956.44
Total=	1404.08	7956.44	9360.52	9211.33	9211.33
Solids=	1404.08	0.00	1404.08	1254.89	1254.89

Composition of plastic-solvent mixture:

Solids = 15% ==> 0.15

Solvent = 85% ==> 0.85

LDPE,HDPE,PP SEPARATION BY SOLVENT

	lb/hr 76	lb/hr 77	lb/hr 78	lb/hr 79	lb/hr 80
LDPE	0.00	0.00	0.00	0.00	0.00
PVC	1254.89	0.00	0.00	0.00	0.00
HDPE	0.00	0.00	0.00	0.00	880.44
PP	0.00	0.00	0.00	0.00	1120.33
PS	0.00	0.00	0.00	0.00	0.00
PU	0.00	0.00	0.00	0.00	0.00
PET	0.00	0.00	149.18	0.00	0.00
SOLVENT	0.00	7956.44	0.00	20661.49	0.00
Total=	1254.89	7956.44	149.18	20661.49	2000.76
Solids=	1254.89	0.00	149.18	0.00	2000.76

	lb/hr 81	lb/hr 82	lb/hr 83	lb/hr 84	lb/hr 85
LDPE	1645.38	1645.38	1645.38	0.00	0.00
PVC	0.00	0.00	0.00	0.00	0.00
HDPE	0.00	0.00	0.00	0.00	0.00
PP	0.00	0.00	0.00	0.00	0.00
PS	0.00	0.00	0.00	0.00	0.00
PU	0.00	0.00	0.00	0.00	0.00
PET	0.00	0.00	0.00	0.00	0.00
SOLVENT	20661.49	20661.49	0.00	20661.49	11337.66
Total=	22306.88	22306.88	1645.38	20661.49	11337.66
Solids=	1645.38	1645.38	1645.38	0.00	0.00

	lb/hr 86	lb/hr 87	lb/hr 88	lb/hr 89	lb/hr 90
LDPE	0.00	0.00	0.00	0.00	0.00
PVC	0.00	0.00	0.00	0.00	0.00
HDPE	0.00	880.44	880.44	880.44	0.00
PP	1120.33	0.00	0.00	0.00	0.00
PS	0.00	0.00	0.00	0.00	0.00
PU	0.00	0.00	0.00	0.00	0.00
PET	0.00	0.00	0.00	0.00	0.00
SOLVENT	0.00	11337.66	11337.66	0.00	11337.66
Total=	1120.33	12218.09	12218.09	880.44	11337.66
Solids=	1120.33	880.44	880.44	880.44	0.00

APPENDIX 2

Technical Information about Dimethylformamide (DMF) *

* Information obtained from the following producers:

Air Products and Chemicals, INC.
BOX 2662, Allentown, PA 18001.

ICI Products
Willmington, Delaware 19897.

DIMETHYLFORMAMIDE (DMF)

Dimethylformamide (DMF) is a clear, colorless and essentially odorless liquid widely used in different commercial areas as solvent. DMF is miscible with water and most common solvents and has high thermal and chemical stability remaining liquid over a wide range of temperature.

Other properties of DMF are

- Solubility Parameter = 12.2
- Boiling Point = 153°C
- Stable up to its atmospheric boiling point
- Over 350°C DMF decomposes in carbon monoxide and dimethylamine.
- At elevated temperature slight hydrolysis occurs increasing in the presence of acids, alkalis, and water.

Among other uses DMF is used as solvent for vinyl based resins such as PVC. Polyethylenes and polypropylene are insoluble in DMF. Polyurethane and polystyrene are soluble in DMF.

PROTECTION INFORMATION

- a) DMF vapors are harmful and may be absorbed through the skin.
- b) The level of DMF vapor in the air have to be maintained below 10 ppm.
- c) When DMF vapor concentration in the air is greater than 10 ppm special protection, such as body, eye, and respiratory protection equipment is required, to avoid health problems.
- d) Carbon monoxide and water spray are good extinguishers to use in case of fire emergency involving DMF.

REFERENCES

- 1 Billmeyer, Fred W., Textbook of Polymer Science, Third Edition. New York: John Wiley & Sons, 1984, pp. 361-369.
- 2 Brandrup, J. and E. H. Immergut, (editors), Polymer Handbook, Second Edition. New York: John Wiley & Sons, 1975.
- 3 Brydson, J. A., Plastics Materials, Third Edition. New York: Van Nostrand Reinhold Company, 1975, pp. 98, 133, 161, 252, 490.
- 4 Curlee, Randall, "Plastics Recycling: Economic and Institutional Issues, "Conservation and Recycling, vol.9, No.4, pp.336-337,339, 1986.
- 5 Dack, Michael, Solutions and Solubilities, Part I. New York: John Wiley & Sons, 1975, pp. 276-281.
- 6 Daniels, C. A., Polymers: Structure and Properties. Pennsylvania: Technomic Publishing Company, Inc., 1989, pp. 71-74, 81-83, 85-87.
- 7 Deanin, Radolph D., Polymer Structure, Properties and Applications. Boston: Cahners Books, 1972, p.618.
- 8 Encyclopedia of Polymer Science and Technology, Vol. 12. New York: John Wiley & Sons, Inc., 1970, pp. 618-626.
- 9 Encyclopedia of Science and Technology, Sixth Edition vol. 14. New York: McGraw-Hill Book Company, 1987, pp. 153-154.
- 10 Hansen, C. M. Journal of Paint Technology, vol.39, p 104, 1967.

- 11 Harper, Charles A., Handbook of Plastics and Elastomers. New York: McGraw-Hill Book Company, Inc., 1975, pp. 1-26, 3-28.
- 12 Henstock, M. E., (editor), "The Recycling and Disposal of Solid Waste." University of Nottingham, Department of Metallurgy and Materials Science. April, 1974, p.139.
- 13 Hildebrand, J. and R. L. Scott, The Solubility of Nonelectrolytes, Third Edition. New York: Reinhold Publishing Corporation, 1950, pp.424-429.
- 14 Hildebrand, J. et al., Regular and Related Solutions. New York: Van Nostrand Reinhold Company, 1970, p 1-7.
- 15 Hildebrand, J. and R. L. Scott, Regular Solutions. New Jersey: Prentice Hall, 1962, pp. 86-87.
- 16 Huyskens, P.L., et al., "Dissolving Power of Solvents," Journal of Coatings Technology, vol.57, No.724, 1985, pp. 57-67.
- 17 Kirk, R.E. and D.F. Othmer, (editors), Encyclopedia of Chemical Technology, vol.18. New York: John Wiley & Sons, 1982, pp. 549-574.
- 18 Kroschwitz, Jacqueline F., (editor), Polymers: An Encyclopedia Sourcebook of Engineering Properties. New York: John Wiley & Sons, 1987.
- 19 Miller, Bernie, "Solvent Separation Can Recover Mixed Plastics," Plastics World, June, 1989, p.15.
- 20 Modern Plastics Encyclopedia. New York: McGraw-Hill Book Company, 1979-80, p.4.
- 21 Modern Plastics Encyclopedia. New York: McGraw-Hill Book Company, 1989, p19.

- 22 Modern Plastics Encyclopedia. New York: McGraw-Hill Book Company, October, 1973, p.745.
- 23 Morrow, Darrell, et al., Overview of Plastics Recycling, reprint edition from TAPPI journal vol.70 NO.12, December, 1987, p. 141.
- 24 Noskr, Thomas J., et al., "Recycle Polystyrene, Add Value to Commingled Products," Plastics Engineering, February, 1990, p.35.
- 25 "Plastics Recycling An Overview." Center for Plastics Recycling Research (CPRR), Rutgers, The State University of New Jersey, Piscataway, p.1.
- 26 "Plastics Recycling: A Strategic Vision." CPRR. p.1.
- 27 Rebenfield, Ludwig, et al. "Interactions Between Solvents and Polymers in the Solid State," Journal of Macromolecular Science, vol C12, No.2, 1976, pp. 307-321.
- 28 "Resin Report 1990." Modern Plastics, January, 1990.
- 29 Rider, Paul E., "Hydrogen Bonding Potential, HBP: A Model for Predicting Resin Solubilities in Organic Solvents," Polymer Engineering and Science, Vol.23 No.1, 1983, pp. 810-815.
- 30 Seymour, Raymond B. and Charles E. Carraher. Structure-Property Relationships in Polymers. New York: Plenum Press, 1984.
- 31 Seymour, Raymond B., "Plastics vs. Solvents," Modern Plastics, October, 1971, pp. 150-151.
- 32 Sheehan, C.J. and A.L. Bisio, Polymer/Solvent Interaction Parameters," Rubber Chemistry and Technology, vol.39, No.1, February, 1966, p.149.
- 33 Smoluk, George R., "PET Reclaims Business Pichs Up New Momentum," Modern Plastics, February, 1988, p.87.

- 34 Snyder, Lloyd, "Solutions to Solutions Problem-1," Chemtech, December, 1979.
- 35 Snyder, Lloyd, "Solutions to Solutions Problem-2," Chemtech, March, 1980, p.188.
- 36 Thayer, Ann M., "Solid Waste Concerns Spur Plastic Recycling Efforts," Chemical and Engineering News, January 30, 1989, p.7.
- 37 "The Urgent Need to Recycle," TIME, July 17, 1989, p.3.
- 38 Yen, T.F., Recycling and Disposal of Solid Wastes. Michigan: Ann Arbor Science Publishers, Inc., 1975, pp.222-233.