

## **Copyright Warning & Restrictions**

The copyright law of the United States (Title 17, United States Code) governs the making of photocopies or other reproductions of copyrighted material.

Under certain conditions specified in the law, libraries and archives are authorized to furnish a photocopy or other reproduction. One of these specified conditions is that the photocopy or reproduction is not to be “used for any purpose other than private study, scholarship, or research.” If a user makes a request for, or later uses, a photocopy or reproduction for purposes in excess of “fair use” that user may be liable for copyright infringement,

This institution reserves the right to refuse to accept a copying order if, in its judgment, fulfillment of the order would involve violation of copyright law.

**Please Note: The author retains the copyright while the New Jersey Institute of Technology reserves the right to distribute this thesis or dissertation**

Printing note: If you do not wish to print this page, then select “Pages from: first page # to: last page #” on the print dialog screen

The Van Houten library has removed some of the personal information and all signatures from the approval page and biographical sketches of theses and dissertations in order to protect the identity of NJIT graduates and faculty.

## ABSTRACT

Title of Thesis

Synthesis and Study of Polymers  
Containing Inorganic Ions

**Lateef Aderoju Ibikunle-Sofoluwe**  
Master of Science in Engineering Science, 1989

Thesis Directed by

Professors Lawrence Suchow

and

William H. Snyder

Cupric and ferrous polyacrylates have been prepared and studied. It was thought that partial reduction of  $\text{Cu}^{2+}$  or  $\text{Fe}^{3+}$  or oxidation of  $\text{Cu}^+$  or  $\text{Fe}^{2+}$  might result in semiconducting behavior but no such effect has been observed. Nevertheless, the results obtained are of considerable interest. Quantitative gravimetric and volumetric studies of cupric polyacrylate precipitation from varying molar ratios of cupric chloride and sodium polyacrylate in aqueous solution have shown that the only product formed is  $\text{Cu}(\text{PA})_2$  (Where PA represents an acrylate mer in polyacrylate). The insolubility of the product indicates that much of the  $\text{Cu}^{2+}$  acts to crosslink molecules rather than simply to replace two adjacent hydrogen ions on the same polymer molecule. The product is blue and hard, though sufficiently brittle to be ground to powder. At high  $\text{H}_2$  pressure in a

Parr bomb, reduction has been achieved at room temperature at which, over a period of ten days, the compound turns black. At 71°C or 91°C, again at high H<sub>2</sub> pressure in a Parr bomb, it turns copper brown in two hours. The reduction products, like cupric polyacrylate itself, are electrical insulators. Because the materials reduced at low temperature should still be quite porous and contain extremely finely divided Cu or a mixture of oxidation states, it is quite possible that they would make excellent catalysts. Diffuse reflectance measurements have been used to define the various colors quantitatively. Cu(PA)<sub>2</sub> and black material are amorphous to x-rays while the copper-brown product has been found to contain crystalline metallic copper. Ferrous and ferric polyacrylates were also precipitated. The former was found to be blue-green and an electrical insulator and the latter yellowish tan and unfilterable. In another preparation, ferrous polyacrylate was first precipitated and then, while still wet, about 20% of it oxidized to the ferric state by addition of I<sub>2</sub>. Whereas ferrous polyacrylate is hard and brittle like cupric polyacrylate, the partially I<sub>2</sub>-oxidized preparation is soft (and yellowish tan). None of the Fe preparations is crystalline to x-rays.

**SYNTHESIS AND STUDY OF POLYMERS  
CONTAINING INORGANIC IONS**

by

**Lateef Aderoju Ibikunle-Sofoluwe**

Thesis submitted to the Faculty of the Graduate School of Engineering of  
the New Jersey Institute of Technology in partial fulfillment of the  
requirements for the degree of Master of Science in Engineering Science

1989

90

APPROVAL SHEET

Title of Thesis:

Synthesis and Study of Polymers  
Containing Inorganic Ions

Name of Candidate:

Lateef Aderoju Ibikunle-Sofoluwe

Master of Science in Engineering Science, 1989

Thesis and Abstract Approved:

\_\_\_\_\_  
Dr. Lawrence Suchow  
Professor of Chemistry  
Department of Chemical  
Engineering, Chemistry, and  
Environmental Science

\_\_\_\_\_  
Date

Faculty Committee:

\_\_\_\_\_  
Dr. Barbara B. Kebbekus

\_\_\_\_\_  
Dr. George Y. Lei

V I T A

Name: Lateef Aderoju Ibikunle-Sofoluwe

Permanent Address:

Degree and date to be conferred:

Master of Science in  
Engineering Science,  
1989

Date of birth:

Place of birth:

Secondary Education: Ibadan Boy's High School  
Ibadan, Nigeria, 1969

<u>Collegiate Institutions</u>	<u>Dates</u>	<u>Degree</u>	<u>Date of Degree</u>
Rutgers University Newark, New Jersey	78-81	B.S.	1981
also attended College of Ozarks Clarksville, Arkansas	75-77		

Major: Engineering Science

Positions Held:

Graduate Assistant, NJIT, Newark, N.J. (9/81-5/84)

Tutor, E.O.P. Program, NJIT (Summers of 1983 and 1984)

DEDICATION

With love and gratitude to the entire Sofoluwe's family, especially my parents - Mr. and Mrs. Ibikunle Sofoluwe and my uncles Chief Towobola and Olajide Esq. for their supports from my very beginnings.

Also to my children and my wife - Yemi; who have given up far too much of their rightful time that I have used in preparation of this thesis.



ACKNOWLEDGEMENTS

I wish to thank Patricia Simmons for her dedication in copying the first draft of this thesis. Also, I wish to acknowledge the assistance of Ms. Sarah Cooper for her professional typing.

My thanks and appreciation to Professors Lawrence Suchow and William H. Snyder, for their professional assistance in directing this thesis. I also thank Dr. Suchow again for his extensive and cogent criticism, assistance, comments and advice that improved final writing of this thesis.

TABLE OF CONTENTS

	<u>Page</u>
DEDICATION.....	ii
ACKNOWLEDGEMENTS.....	iii
TABLE OF CONTENTS.....	iv
LISTS OF TABLES.....	vii
LISTS OF FIGURES.....	viii
GLOSSARY.....	ix
I. INTRODUCTION.....	1
A. GENERAL.....	1
B. BACKGROUND.....	2
i. Mixed Valence Compounds.....	2
ii. History.....	2
iii. The Organic Solid State.....	4
iv. Conducting Organic Polymers.....	9
v. Ionomers and Polyelectrolytes.....	10
vi. Theory and Classification.....	12
a. Class I .....	12
b. Class II .....	13
c. Class III .....	14
vii. Semiconductors.....	16
viii. Relevant Copper Compounds.....	17

II. EXPERIMENTAL.....	20
A. Materials Used for Synthesis.....	20
i. Copper (II) Chloride.....	20
ii. Copper (I) Oxide.....	20
iii. Polyacrylic Acid.....	20
B.     i. Analytical Chemistry.....	21
ii. Titration and Acid Strength.....	22
C.     General Analysis Procedure.....	27
i. Copper (I) Polyacrylate.....	29
a. Attempted Preparation of Cu(I)PA....	29
b. Standardization.....	30
1. Preparation of potassium hydrogen phthalate ( $\text{KHC}_8\text{H}_4\text{O}_4$ ) solution.....	30
2. Standardization of NaOH solution from primary potassium hydrogen phthalate standard.....	31
3. Standardization of HCl solution.....	32
4. Standardization of PAH solution.....	34
c. X-Ray Diffraction.....	35
ii. Copper (II) Polyacrylate.....	37
a. Preparation of $\text{Cu}(\text{PA})_2$ .....	37
b. Polyacrylic Acid and Sodium Polyacrylate Solution.....	37
c. $\text{CuCl}_2$ .....	39
d. Preparation of Aqueous Solution.....	42
e. Comparison of Theoretical and Actual Experimental Yield.....	46

1. Percentages of copper in samples and filtrates.....	46
2. Percentages of chloride in filtrates....	50
f. Reduction of Samples in:	
1. Ceramic tube.....	53
2. Parr bomb.....	57
g. Electrical Measurements.....	59
h. Flame Test.....	62
i. Acid Test.....	63
j. X-Ray Diffraction.....	64
k. Diffuse Reflectance Spectra.....	65
iii. Ferrous and Ferric Polyacrylate.....	70
III. DISCUSSION AND RESULTS.....	71
IV. CONCLUSION.....	76
V. REFERENCES.....	79
VI. BIBLIOGRAPHY.....	83

LIST OF TABLES

<u>Table</u>		<u>Page</u>
1.	X-Ray Diffraction Powder Patterns.....	36
2.	Amounts of Reactants Used.....	43
3.	Masses of Copper Polyacrylate Salts Obtained.....	44
4.	Titration of Aliquots of Filtrates with $\text{Na}_2\text{S}_2\text{O}_3$ .....	45
5.	Percentage of Copper in Samples and Filtrates.....	48
6.	Yield Data of Copper Polyacrylate Salts in Precipitates.....	49
7.	Masses of Chloride in Filtrates.....	51
8.	Percentage of Chloride ( $\text{Cl}^-$ ) in Filtrates.....	52
9.	Observations of Effect of Temperature and atmosphere on PAH and Copper Polyacrylate Preparations.....	55
10.	Sample Reduction in Parr Bomb (in 100% $\text{H}_2$ ).....	58
11.	Resistivities of Samples Heated or Reduced in a Ceramic Tube in Flowing $\text{H}_2$ .....	60
12.	Resistivities of Products on Reduction in Parr Bomb at High $\text{H}_2$ Pressure.....	61
13.	Flame Test Observations.....	62
14.	Acid Test (Reaction of $\text{Cu}(\text{PA})_2$ Samples with conc. $\text{HCl}$ ).....	63
15.	X-Ray Diffraction Powder Patterns.....	64
16.	Absorption Peaks in Diffuse Reflectance Spectra.....	65

LIST OF FIGURES

	<u>Page</u>
Figure 1. Schematic Representation of the allowed energy states.....	8
Figure 2. (a,b,c,) pH titrations of polyacrylic acid (PAH).....	23-25
Figure 3. Muffle Furnace (sample reduction in Ceramic Tube).....	54
Figure 4. Muffle Furnace (sample reduction in Parr bomb).....	56
Figure 5. $\text{Cu}(\text{PA})_2$ - (As prepared, no reduction) blue.....	66
Figure 6. $\text{Cu}(\text{PA})_2$ - reduced in 100% $\text{H}_2$ in Parr bomb for ten days at 25°C (black).....	67
Figure 7. $\text{Cu}(\text{PA})_2$ - reduced in 100% $\text{H}_2$ in Parr bomb at 71°C.....	68
Figure 8. $\text{Cu}(\text{PA})_2$ - reduced in 100% $\text{H}_2$ in Parr bomb at 91°C.....	69

GLOSSARY

The abbreviations used in this thesis are defined as follows:

PAH = Polyacrylic acid

PA = Polyacrylate (with acrylate mers)

Mol = Mole

M = Molarity

g = Grams

mL. = Milliliter

L = Liter

cm = Centimeter

Soln=Solution

gmw = Gram Molecular Weight

V. or Vol. = Volume

## I. INTRODUCTION

### A. GENERAL

The objectives were to synthesize and characterize mixed-valence copper and iron salts of polyacrylic acid which might then behave as semiconductors. It was postulated that the material could be semiconducting if it possessed the same metal ion in more than one oxidation state. It is crucially important to obtain and maintain the ions of each oxidation state without their being oxidized or reduced when exposed to the atmosphere.

In aqueous solution, the interaction of copper ions with polyacrylic acid is not a simple electrostatic phenomenon since the behavior of copper is markedly different from that of the alkaline earths.<sup>1</sup>



## B. BACKGROUND

- i. Mixed Valence Compounds: A Mixed valence salt is a chemical compound which contains ions of the same element in two different formal states of oxidation. The largest number and greatest variety of such compounds to be encountered involve the transition elements since many of these elements can exist in a variety of oxidation states.
- ii. History: According to Robin and Day<sup>2</sup>, the history of mixed valence chemistry began with the synthesis in 1704 of one of the first coordination compounds, Prussian blue.<sup>3</sup> The early history of the mixed valence phenomenon consists of two phases. In the early phase, it was based on the color and conditions for its appearance. In 1847, Berzelius<sup>4</sup> described the blue-black ink derived from tannin - containing gall nuts as a double salt of Fe(II) and Fe (III) ions, similar to the other blue iron salts then known to contain these ions simultaneously. Werner<sup>5</sup> commented on extraordinary colors and metallic sheen of certain Pt(II)-Pt(IV) oxalate complexes he newly synthesized, basing his results on simultaneous presence of oxidizing and reducing species. Hofmann<sup>6</sup> and later McCarthy<sup>7</sup> explained that the simultaneous presence of Fe(II) and Fe(III) in minerals leads to deep colors, black if the mineral is anhydrous, blue if it is hydrated.

The historical second phase was based on the fact that the different valences are not uniquely fixed, one to each ion, but oscillate rapidly in a mixed valence system, and that the results of

this unique valence oscillation results in a unique absorption of light, that is, color. Thus, in 1915 Hofmann and Hoschele<sup>8</sup> suggested that the blue color of "cerium-uranium blue," a mixed oxide of  $UO_2$  and  $CeO_2$  was the result of the valence oscillation, because distribution of oxidation states; e.g., the equilibrium  $Ce_2^{IV,IV}U^{IV}O_6 \rightleftharpoons Ce_2^{III,VI}U^{VI}O_6$  can occur under the influence of light so as to produce light absorption and hence the color. This situation occurs most frequently when the same element is present in different valence states in the same compound. Wells<sup>9</sup> came to the conclusion that the "spontaneous electronic activity" present in mixed valence compounds must also result in enhanced electrical conductivity. In the cases of Au(I)-Au(III) and Sb(III)-Sb(V) there is a difference of two units of valency, while with Fe(II)-Fe(III) and Cu(I)-Cu(II) there is a difference of one unit. The action of this chromophore is due to exchanges in electrons between the atoms that differ in valency; that is, in passing from one valency to another an atom gives up or takes on one or more electrons, which is a continuous process of exchanges, instead of retaining fixed individual valences. Light passing through such materials is affected, so that colors or opacity are produced. Streintz<sup>10</sup> found that white, yellow, red, and grey powders of mixed valence compounds do not conduct electricity whereas the deeply colored ones may show metallic behavior. Biltz<sup>11</sup> outlines the origins of the colors of various inorganic materials, in that the color change on mixing arises not from an oscillation of

valence between different metal ions, but instead from a change in the ligand field about one of the components on going into the mixed crystal. Finally, Stieglitz<sup>12</sup> expressed the thought that the deep color of many inorganic substances was intimately connected with the interatomic oxidation-reduction tendency of the compound. Thus, in mixed valence systems, he pointed out that intense colors can result from photochemical oxidation-reduction, the electrode potentials permitting, and that there is no compelling need to introduce an oscillation of the valences.

iii. The Organic Solid State:<sup>13</sup>

The study of organic radical cation salts like those derived from the electron donor tetrathiafulvalene (TTF) and its selenium and tellurium analogs has given us a wealth of information about a new area of chemistry and physics. Most organic solids are electrical insulators. However, several salts formed from the organic electron acceptor tetracyanoquinodimethane (TCNQ) and donor ions were discovered to be semiconductors in the 1960s, primarily as a result of work at DuPont. In 1972, Dwaine O. Cowan, John P. Ferraris and their group at John Hopkins found that single crystals of the salt TTF-TCNQ showed metal-like electrical conductivity. Specifically, single crystals of TTF-TCNQ have a conductivity of about  $500 \text{ (ohm-cm)}^{-1}$  at room temperature. (For comparison, metallic copper has a room temperature conductivity of about  $10^6 \text{ (ohm-cm)}^{-1}$ ). Also, the conductivity of TTF-TCNQ increases as temperature decreases, as is true of metals, until

a maximum conductivity of about  $10^4(\text{ohm-cm})^{-1}$  is reached at 59K. Below 59K, conductivity drops off and behave like a semiconductor - that is, the conductivity decreases with decreasing temperature. The electrical conductivity in TTF-TCNQ is also highly anisotropic, varying along different crystal axes. The ratio of the conductivity in the three principal directions is approximately 500:5:1. The synthesis of TTF-TCNQ was a conscious effort on the part of the Hopkins group to optimize those factors that are likely to produce an organic metal.

In the salt (e.g. TTF-TCNQ), the molecular species exist in two kinds of stacks: One contains solely TTF molecules; the other is made up of TCNQ molecules. This gives rise to the term segregated stacking. The direction of high conductivity is along these stacks

The short interplanar distances between adjacent molecules ( $3.17 \text{ \AA}$  for TCNQ and  $3.47 \text{ \AA}$  for TTF) allow significant interaction between  $\pi$ -molecular orbitals of neighbors, leading to formation of a band (that is, a restricted range of allowed energies for the electrons) in the solid.

When a great number of atoms (as in elemental metals or semiconductors) or molecules (as in organic metals) are brought together into a crystalline solid, the electronic states mix so as to form bands, each band consisting of electronic states whose energies form a continuous range. This is analogous to the splitting of atomic energy levels as two atoms are brought together to form a molecule with higher and lower energy levels.

With the combination of  $10^{20}$  or so atoms and translational periodicity, energy levels are continuous over a range called the bandwidth. In fact, usually more than one band is available. The bands may overlap in energy or there may be an energy gap, that is, a range of forbidden energies. In band theory the appropriate quantum number is called the wave factor; it represents the momentum of the electron.

The highest occupied state is called the Fermi level. Only the states that are near in energy to the Fermi level are readily accessible and influence physical properties, because it requires too much energy to promote an electron into empty states above the Fermi level. If the highest filled band (the valence band) is only partially full, empty states will exist infinitesimally close to the Fermi level, and those electrons nearby in energy can take part, for example, in electrical conduction. On the other hand, if the highest filled band is entirely full, and there is some band gap between it and the next higher band (conduction band) then a relatively large energy (compared to the available thermal energy) will be needed to put electrons into states where they will be available for conduction and where they may influence other properties.

However, with exactly one electron per molecule, electrical conduction (moving electrons down the chain) must involve placing two electrons on the same molecule with a consequent energetic penalty because of the coulomb repulsion (the repulsive force between like charges). Therefore, single electrons become associated with each molecule, hence, insulating properties result (Fig. 1A).

A completely filled valence band leads to semiconducting properties if  $E_G$  is small or if doped with impurities. In this case, there are fewer electrons around to serve as charge carriers, and the number of available carriers is strongly dependent on temperature. At higher temperatures, more electrons can be promoted into the conduction band, and hence conductivity increases with increasing temperature (Fig. 1B).

Metallic conductivity is associated with an incompletely filled band which has a large number of electrons available for conduction or overlap of a filled band and an empty band. (Figs, 1C(a) and 1C(b).) The dominant influence on the electrical conductivity is scattering of these electrons by lattice vibrations (called phonons). Because there are fewer vibrations at lower temperatures, the conductivity of a metal increases as temperature falls.

Recent research has led to a number of new conducting charge-transfer salts. In general, the donor and acceptor components are planar molecules with an extended  $\pi$  network. These planar molecules are stacked in a close array, with a relatively small distance, typically 3 to 4 Å.

These donor-acceptor salts can form a segregated stacking pattern, of which there are two kinds, or they can form mixed-stack structures, which are limited to being semiconductors or insulators.

When the molecules are in segregated stacks, a band of electronic states is formed from the  $\pi$ -molecular orbitals of individual molecules. The  $\pi$ -highest occupied molecular orbital ( $\pi$ -HOMO), for a donor, or  $\pi$ -lowest unoccupied molecular orbital ( $\pi$ -LUMO), for an

SCHEMATIC REPRESENTATION OF THE ALLOWED ENERGY STATES

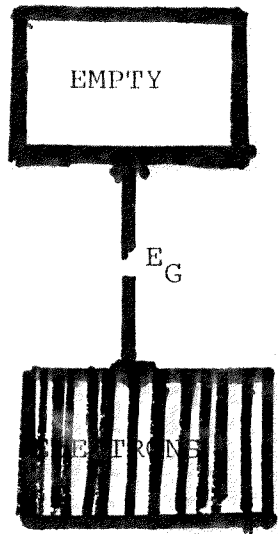

Fig. 1A  
INSULATOR

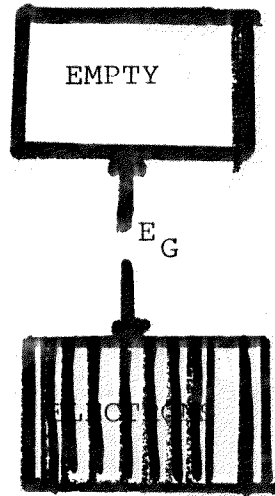

Fig. 1B  
SEMICONDUCTOR

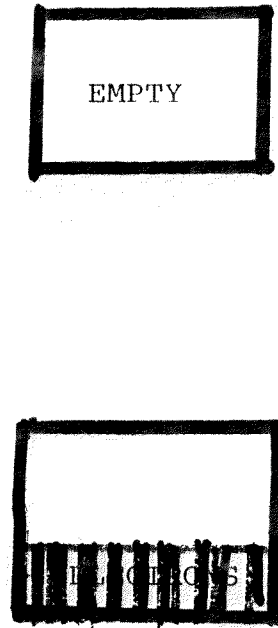

Fig. 1C(a)  
e.g. sodium

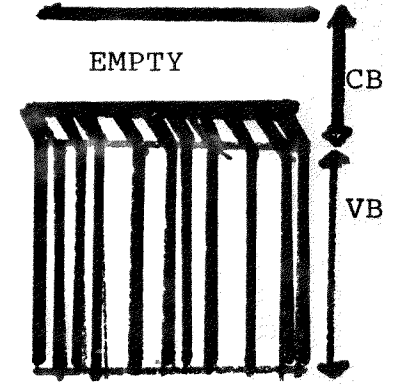
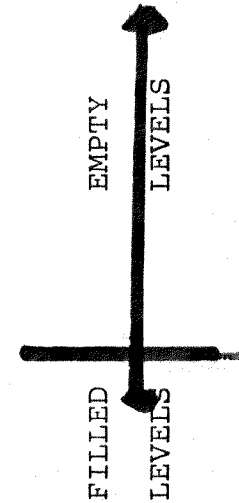

Fig 1C(b)  
e.g. magnesium

Insulator

Semiconductor

Metal

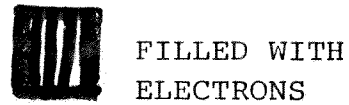

Fig. 1

acceptor play the role of  $\pi$  atomic orbitals in Huckel theory. Band filling in segregated - stack salts is determined by the extent of charge transfer from donor to acceptor molecules.

iv. Conducting Organic Polymers: Some organic polymers have shown unusually high conductivity - at least by comparison with the typical electrical properties of organic polymers. Polyacetylene was the first organic polymer to show significant conductivity. When polyacetylene is oxidized (by electron acceptors such as iodine or arsenic pentafluoride) or reduced (by donors such as lithium), its electrical conductivity increases by orders of magnitude, up to a maximum of about  $500 \text{ (ohm-cm)}^{-1}$ . Besides polyacetylene, high conductivity has been reported for many chemically treated samples of poly-p-phenylene polyaniline, polypyrrole and others.

The process by which conduction is attained in these normally insulating polymers is frequently called doping, by analogy with the doping of semiconductors. The electronic properties of pure semiconductors are altered by addition of small, controlled amounts of other elements, for example, boron or phosphorus added to silicon. However, the mole fraction of added material needed for the polymers is much larger, approximately 0.01 to 0.1, based on monomer units, rather than  $10^{-5}$  to  $10^{-8}$  in the case of inorganic semiconductors. Polymer doping involves introduction of a different chemical species and also oxidation or reduction of the polymer itself.

However, in the process of oxidation, electrons are removed from the band. Therefore, the band is only partially occupied and electrical conduction becomes possible, given the proper conditions of electron



mobility, bandwidth and other affects. Likewise reduction puts electrons into the lowest unoccupied band, thereby facilitating conduction.

v. Ionomers and Polyelectrolytes: During the past few years, ion-containing polymers have been the subject of extensive studies. Even the solid state of these materials, which until recently had received only scant attention, has been under detailed scrutiny in several laboratories, both industrial and academic.<sup>14-16</sup> Usually, ionomers are defined as synthetic organic co-polymers containing some hydrocarbonomers and have an inorganic ion content up to 10-15 mol. % of available sites. They are generally insoluble in water because of the hydrocarbon content.<sup>17</sup> Polyelectrolytes, which could really also be considered as ionomers with no hydrocarbon present, can have much higher inorganic ion content, and are usually insoluble in organic solvents and sometimes also in water, especially with multivalent cations. Specifically, an ionomer can be defined as an ionized copolymer where the component is a non-ionic backbone, usually hydrocarbon, and whose minor component consists of ionic co-monomers, with associated counterions. The ionic groups may either have been copolymerized with the major components or have been introduced by modifying a non-ionic polymer through appropriate chemical techniques. The ionic component, frequently in the form of pendant carboxylic or sulfonic acid groups, is then partially or completely neutralized to form the ionomer, a polymer salt. Neutralization is effected by bases or halides of elements or groups such as sodium, zinc or ammonium.

Mixed valence systems are of great interest because as with resonating organic molecules, there frequently is an interaction between the metal ions which results in the most dramatic changes in the physical properties of the systems; for example, paramagnetic substances may become ferromagnetic or diamagnetic, all by changing the oxidation state of some of the metal ions in the system by one or more units. Hence, there are inter-relationships among the electronic structure, molecular structure, electronic spectra, electronic conduction, and magnetism. The most obvious and striking feature of many mixed valence compounds is the presence of intense absorption in the visible region of the spectrum.

Classical polymers<sup>18-22</sup> have been extensively employed in the electrical industry as coatings of wires because of their low electrical conductivity, high insulation properties (e.g., polyethylene,  $\rho=10^{17}$  ohm-cm). Ion-containing polymers provide alternate electrical uses where the polymeric nature of the metal - containing polymers may be envisioned to increase the electrical conductivity of the polymer. An electron in an insulator ( $\rho=10^{14}$  ohm-cm), cannot "hop" from one group to the next. Another approach related to improving the electrical and other selected properties, is the reduction of metal-containing polymers permitting a chemical method of forming metals, plastics, composites, etc. (with selected metal oxides or chlorides present in a homogenous fashion in very small particle size). Considerable interest has been expressed<sup>23, 24</sup> in these products because of their high rigidity and thermal stability and because partial oxidation or reduction could produce conjugated mixed valence materials which may act as semiconductors or metals.

vi Theory and Classification<sup>2</sup>

The theory of the electronic structures of mixed valence materials offers a foundation for a valuable classification scheme since each of the classes as defined exhibits certain easily recognized physical properties which are characteristic of that class, viz: wave functions, spectra, magnetism, and electron transport. However, the discussion here will focus primarily on the mixed valence spectra, magnetism, and electron transport.

a. Class I: Absorption bands occur at frequencies higher than  $27,000 \text{ cm}^{-1}$ , for these materials are usually colorless. Those that show absorption in the visible invariably contain a colored ion as a constituent, their visible spectra being merely sums of the spectra of the constituent ions and nothing more. Virtually all the colorless class I systems involve transition metal ions, which are quite stable in the ground state, but which are relatively unstable in the mixed valence upper state. Actually, no new absorption has ever been observed in Class I mixed valence system.

The electrons which distinguish the valence of one ion from another are so firmly trapped that virtually no magnetic coupling between partly filled shells on adjacent metal ions is possible, and these substances are paramagnetic (if paramagnetic ions are present) down to very low temperature. That electron transfer can occur only at the expense of a large amount of energy means they are electrical insulators. In such a case, two electrons occupy each state of the

energy band up to the Fermi surface, so that with completely filled inner shells and in the absence of a magnetic field, each atom has no net spin. By Lenz' law, the moments give a diamagnetic susceptibility, but the atomic movement can exist through induction by an applied field which might alter the population of the electron states, producing a temperature-independent Pauli paramagnetism. On the other hand, if each cation contributes either zero or two electrons to a band, then the band is either completely empty or filled and in either case the material is an insulator. According to Mott<sup>25</sup>, transition metal oxides like NiO with incompletely filled d-shells and bridging anions separating the cations are also insulators.

b. Class II: These are characterized by an absorption band in the visible region of the spectrum ( $14,000-27,000 \text{ cm}^{-1}$ ) which is absent in the spectra of the constituents taken separately. The perturbation of the wave function can be sufficiently small so that constituent ion absorption can also still be recognized. Similar constituent ion absorption can be found in the infrared and Mossbauer spectra of Class II compounds. Highly hydrated mixed valence compounds have only the pale color of their constituent ions, but become more deeply colored as the water is removed since water is not a bridging ligand and would promote formation of a Class I system when present in large proportions. However, as the water is removed the empty sites must be filled by ligand anions which can bridge two metal ions and thereby turn the compound into a more deeply colored Class II system (Fig. 1B).

They are semiconductors but with low conductivities as compared with Class III-B so that they have weaker ferro-magnetic interaction if magnetic ions are present. Thus they will remain paramagnetic down to much lower temperatures. At lower temperatures, they may go either ferromagnetic or antiferromagnetic depending upon the relative strengths of the interaction between like and unlike valences.

c. Class III-A: These materials contain polynuclear mixed valence anions, cations and neutral species in which the sites of all metal ions are equivalent. The excitation energies depend upon ligand field splittings and molecular orbital resonance integrals, just as they do in an ordinary polynuclear complex having metal-metal bonds. There are therefore new absorptions resulting from interactions between constituent ions but there are no recognizable constituent ions spectra. There are also semiconductors with conductivity greater than in class II.

Class III-B: These are like Class III-A but are metals and as such show an absorption edge usually in the infrared, and are opaque with metallic reflection in the visible region. The cations in Class III-B contribute, on the average, an intermediate number of electrons to the band, filling it only partially, hence there is metallic conductivity. Tungsten bronzes are good examples, for they have temperature-independent paramagnetic susceptibilities and metallic conductivities. The resistivities of a number of class III-B mixed valence materials at room temperature are of order of magnitude approximately  $10^{-3}$  ohm-cm.<sup>26</sup> The possibility of ferromagnetic ordering between the local magnetic

moments in the transition metals was first considered by Zener<sup>27</sup>, who proposed that, in the metallic state, it was the conduction electrons which coupled the d-shell moments together. Since, according to Hund's rule, the lowest energy configuration within each d-shell has the spins of all of the unpaired electrons parallel, if the conduction electrons are to carry their spins unchanged from atom to atom, they must move in an environment of parallel spins, that is, the moments of all the atoms must point in the same direction.

According to Carraher<sup>18</sup>, Class I compounds have essentially no interactions between valence centers, being typically non-conductors or poor semiconductors with  $\rho = 10^{10}$  ohm-cm. for example, polyvinyl chloride (Fig. 1A). Class II compounds have weak interaction between valence centers as indicated by valency transfer bands in the visible to near-infrared spectral region, being semiconductors with  $\rho = 10^{18}$  ohm-cm for example, silicon (Fig. 1B). Class III compounds have strong interactions between the metal sites making such materials semiconductors or metals, for example copper (Fig. 1C).

vii. Semiconductors:<sup>28</sup> As the name implies, a semiconductor is a substance whose electrical conductivity lies between that of a metal (e.g., copper, resistivity  $1.7 \times 10^{-6}$  ohm-cm) and an insulator, (e.g., poly (vinyl chloride) resistivity  $1 \times 10^{10}$  ohm-cm). (Values at room temperature.) Resistivities of semiconductors range from about 0.001 ohm-cm (heavily doped germanium) to  $3 \times 10^5$  ohm-cm (intrinsically pure silicon).

The electrons of any atom exist in different energy levels about the nucleus. These levels are discrete rather than continuous and are a function of the particular atomic species. However, because of the large number of atoms, the various energy levels form distinct groups of essentially continuous levels which are known as energy bands. In insulating materials the valence band is filled and there is a considerable energy gap (i.e. forbidden energy levels) between it and the conduction band so that only an insignificant number of electrons can acquire thermal energy required to jump the gap (Fig. 1A). In intrinsic-semiconductor materials the valence band is filled, but the energy gap between it and the conduction band is small enough so that an appreciable number of electrons (which are free, at least momentarily, from the atoms of the semiconducting materials) jump the gap at room temperature because of thermal agitation (Fig. 1B) (e.g., in germanium about  $10^{14}$  electrons per cubic meter are in the conduction band at  $27^{\circ}\text{C}$ ). In metallic materials the valence band is not filled, and it overlaps the conduction band, and therefore there are numerous available energy levels to which an electron can be excited (Fig. 1C).

An electron which has escaped into the conduction band leaves behind an ionized atom. Hence, the principal elementary charges are ions, i.e. atoms which have lost one or more electrons (positive ions) or gained one or more electrons (negative ions). When so removed, the electron leaves the immobile atom positively charged. Moreover, the electron vacancy thus formed has the statistical properties of a positive particle known as a "hole". Therefore, when electrons are transferred from atom to atom through the body of the semiconductor, two types of current can occur: a negative electron current caused by the motion of the electrons themselves and a positive hole current represented by the change in position of the electron vacancies. Therefore, measurement of resistivity is, in fact, the only practical means of determining the semiconductivity of a material.

viii. Relevant Copper Compounds: A wide variety of mixed valence copper compounds have been described, the majority containing halide ligands, e.g.  $\text{Cu}_3\text{Br}_4(\text{Pyr})_2$  (Pyr = dipyridon). Of the halides, a large number appear to fall into Class I, in which the environments of the metal ions in the two oxidation states are very different and there are no bridging ligands. Souchay<sup>29</sup>, who prepared salts with empirical formulas  $\text{Cu}_3(\text{Br}_4)(\text{Pyr})_2$  and  $\text{Cu}_3\text{Br}_4(\text{Ant})_5(\text{H}_2\text{O})_6$  (Ant=antipyridine), measured the conductivities of their solutions in acetone and concluded that they contained, for example,  $(\text{Cu}^{\text{II}}(\text{Pyr})_2)^{2+}$  and  $(\text{Cu}^{\text{I}}\text{Br}_2)^-$ . The colors of the solids were dark green and yellow-green respectively. Later, a large number of similar complexes were prepared<sup>30-32</sup> with simpler ligands, such as ammonia and ethylenediamine which have the general formula  $(\text{Cu}^{\text{II}}\text{A}_4)(\text{Cu}^{\text{I}}\text{X}_2)_2$  or  $(\text{Cu}^{\text{II}}\text{A}_4)(\text{Cu}^{\text{I}}\text{X}_3)$



where (A=ammonia or half of bidentate ethylenediamine and X=Cl, Br, or I). Compounds with similar formulas were prepared<sup>33-35</sup> containing  $\text{Cu}^{\text{II}}$  and  $\text{Ag}^{\text{I}}$ , which, when vigorously shaken with water, decompose to  $\text{AgX}$  leaving  $(\text{CuA}_4)^{2+}$  in solution. The chlorides and bromides were reported as deep blue or violet, but iodides were all brown or black. Additional compounds of the same type were prepared.<sup>36</sup> Compounds in which X is  $\text{CN}^-$  have also been recognized for many years.<sup>37-40</sup>

A series of chlorocuprates (I, II) in which the color is clearly due to mixed valence absorption were first prepared by Mori.<sup>41</sup> When hexaamminecobalt (III) chloride solution is added to an aqueous solution of either  $\text{CuCl}$  or  $\text{CuCl}_2$  containing excess chloride ions, orange-yellow crystals are obtained, but if the solution contains both  $\text{CuCl}$  and  $\text{CuCl}_2$  the resulting crystals are brown or black depending on the mole fraction of each valence state present. By measuring diffuse reflectance spectra, Mori found the new absorption band in the mixed valence material to be near

42.  
 $17,000 \text{ cm}^{-1}$  The electrical resistivities of the chlorocuprates (I, II) have also been investigated.<sup>43</sup> They are high resistance semiconductors and at room temperature the specific conductivities, like the interaction absorption intensities, are proportional to the product of the mole fractions of the two valence states.

Cuprous ( $\text{Cu}^+$ ) and cupric ( $\text{Cu}^{2+}$ ) compounds<sup>44</sup> are quite numerous and the  $\text{Cu}^{+3}$  form occurs in only a few unstable compounds. Although it is easy to oxidize metallic copper to the +1 state in the presence of various precipitating and complexing agents, the +2 state is the more

stable in aqueous solution. Because copper possesses all of the factors favoring true complex formation involving covalent bonds, a wide variety of coordination compounds can be prepared exhibiting coordination numbers of two ( $\text{Cu}^+$ ) and four ( $\text{Cu}^{2+}$ ).

## II. EXPERIMENTAL

### A. Materials used for Synthesis

i. Copper (II) Chloride<sup>45, 46</sup> The anhydrous salt forms dark brown crystals melting at 498°C. It gives a variety of hydrates with four (below 15°C), three (below 26°C), two (below 42°C) and one (up to 117°C) molecules of water.

ii. Copper (I) Oxide: Red cuprous oxide,  $\text{Cu}_2\text{O}$ , is diamagnetic with reddish-brown octahedral crystals. It is soluble in acids such as nitric or sulfuric but is converted by them to the cupric salt. It is also soluble (with oxidation) in ammonium hydroxide but insoluble in water or alkaline solutions. Its specific gravity is 5.75-6.89, its melting point is 1235°C and its boiling point is 1800°C.

iii. Polyacrylic Acid (PAH): The polyacrylic acid used<sup>47</sup> was "Carbopol" resin manufactured by B.F. Goodrich Chemical Group, but purchased from Scientific Polymer Products, Inc. (Cat #597). Carbopol resins are acrylic acid polymers crosslinked with a polyalkenylpolyether. They are fluffy, dry powders with an average equivalent weight of 76 (rather than the theoretical 72, apparently because of impurities in or out of the polymer chain). The PAH readily reacts to form salts. The type used for synthesis is Carbopol 910 with molecular weight approximately 750,000.

Aqueous dispersions of Carbopol resins have an approximate range of 2.8 to 3.2 depending on resin concentration (the higher the carboxyl concentration, the lower the pH). The general structure is

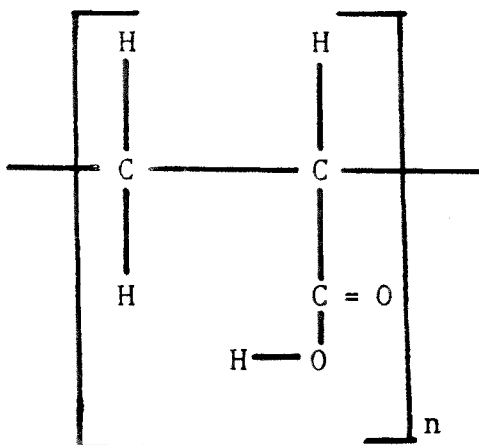

In the series of alkali metal salts, binding to poly (acrylic acid) decreases in the order  $\text{Li} > \text{Na} > \text{K} > \text{Rb}$ .<sup>48</sup>

When polyacrylic acid is heated, anhydride formation starts at  $250^{\circ}\text{C}$ - $260^{\circ}\text{C}$  and the polymer becomes insoluble. On further heating, the anhydride decomposes rapidly at about  $400^{\circ}\text{C}$ . However, no monomer is formed.

#### B. i. Analytical Chemistry

Metal salts of acrylic acid can be prepared by neutralization with hydroxides, carbonates, chlorides, or by saponification of the esters with bases that are at least as strong as sodium hydroxide or calcium hydroxide.<sup>49</sup> When poly(acrylic acid) is partially neutralized with sodium hydroxide, it is found that an appreciable number of the sodium ions become bound to the polymer anion in solutions in such a way that are carried along with the anion during electrical transference, diffusion, etc.<sup>50-52</sup>.

When ions, such as sodium or strontium are introduced into such a system, it is found that they are preferentially taken up by polyanions, which appear to act as miniature ion-exchange systems. The binding of ions like sodium or calcium appears to be essentially electrostatic in character, since ordinary equilibrium considerations cannot account for the binding quantitatively. However, it was found<sup>53</sup> that the interaction of copper (II) with poly (acrylic acid) in aqueous solution results in formation of complex structures which appear to involve intramolecular pairs of carbonyl groups associated with copper ions.

#### ii. Titration and Acid Strength

The potentiometric titration of poly(acrylic acid) has been studied by many investigators, principally Kern,<sup>54</sup> Katchalsky,<sup>55</sup> Overbeck,<sup>56</sup> Doty<sup>57</sup> and Gregor<sup>58</sup>. Poly (acrylic acids) are weaker acids than their monomeric counterparts and their titration curves (plots of pH versus fraction neutralized) rise more slowly with increased neutralization (Figs. 2a,b,c contain our data). The decrease in acid strength with increased neutralization occurs because the ionized carboxyl group decreases the tendency of its neighbors to ionize according to the Henderson-Hasselbach equation (which is derived as follow).<sup>59</sup>



$$\log K_a = \log(\text{H}^+) + \log (\text{A}^-) - \log (\text{HA})$$

$$-\log K_a = -\log(\text{H}^+) - \log (\text{A}^-) + \log (\text{HA})$$

$$\text{pKa} = \text{pH} - \log \frac{(\text{A}^-)}{(\text{HA})}$$

$$\text{pH} = \text{pKa} - n \log((1-\alpha)/\alpha)$$

POLYACRYLIC ACID TITRATION CURVE (pH vs. Vol. NaOH)

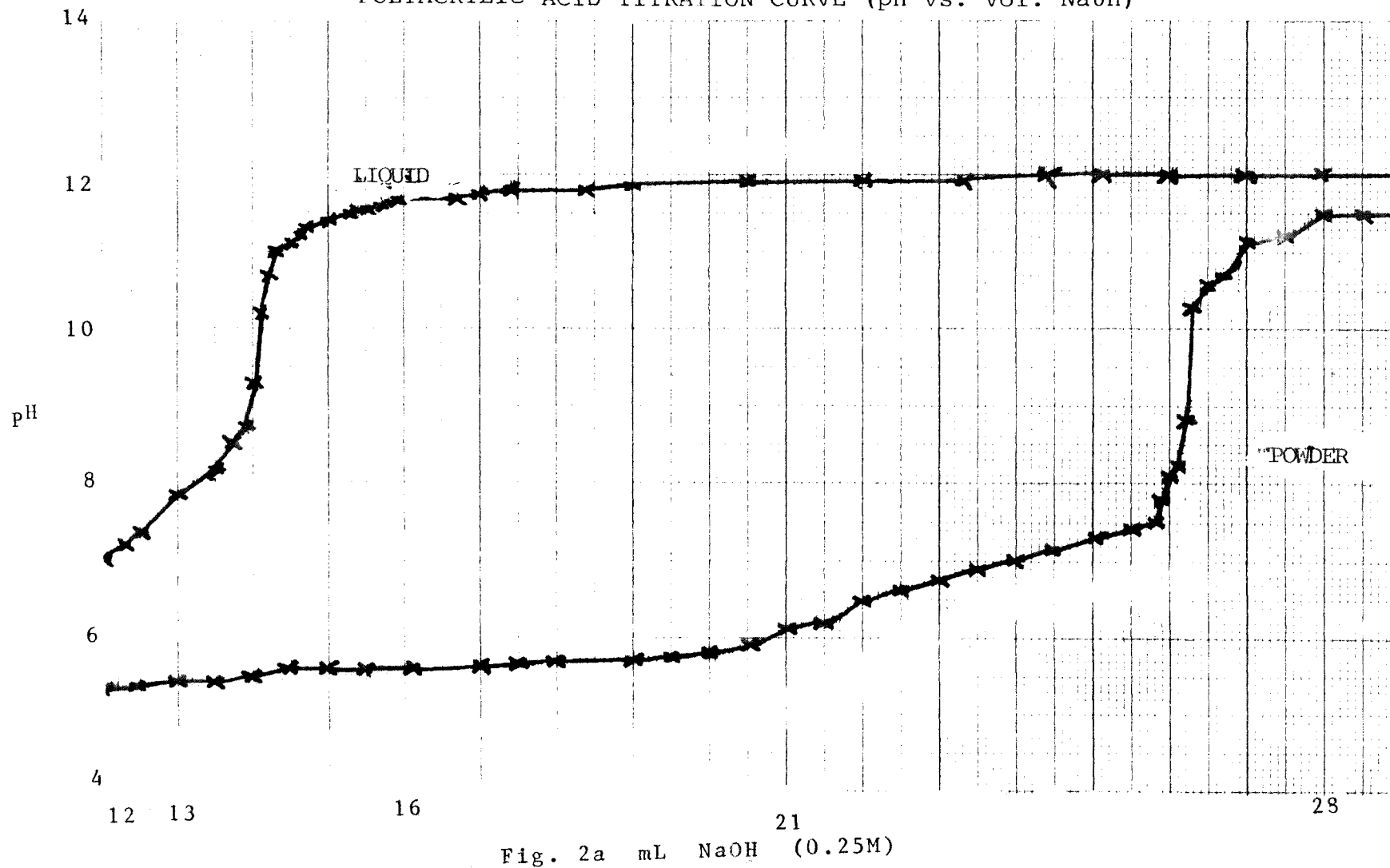
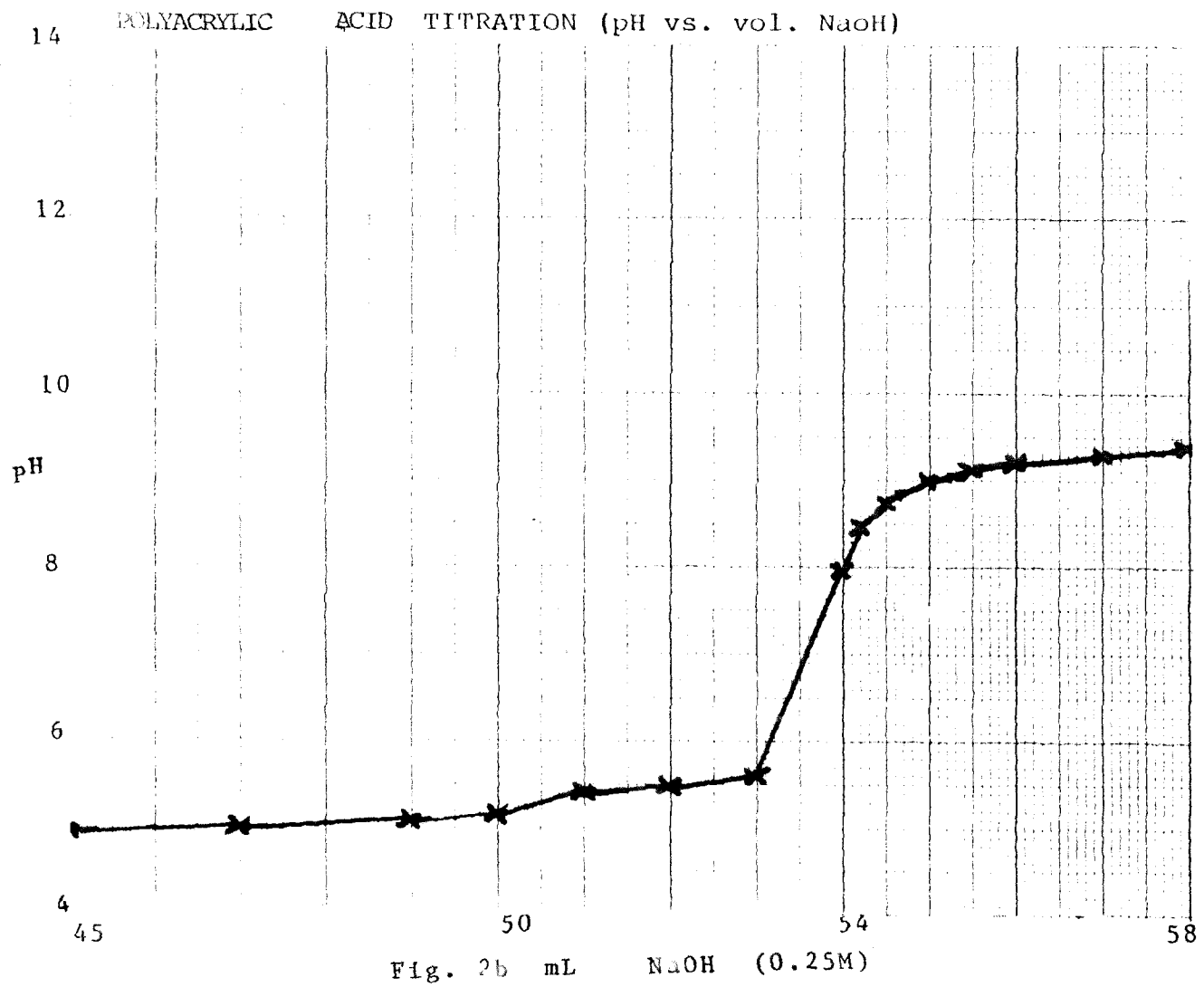

Fig. 2a mL NaOH (0.25M)



POLYACRYLIC ACID TITRATION (pH vs. Vol. NaOH)

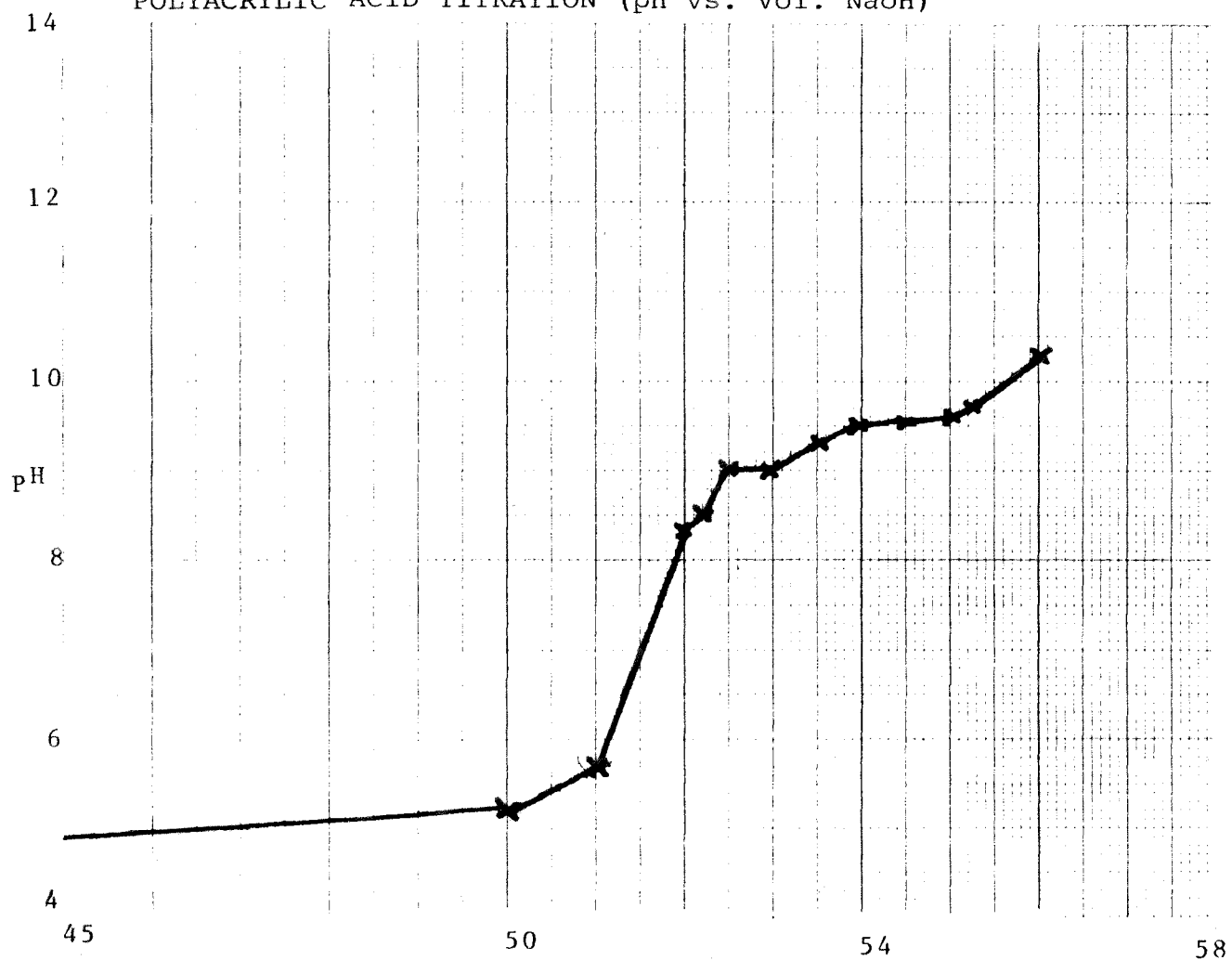

Fig. 2c mL NaOH (0.25M)



where  $\alpha$  = degree of neutralization.  
 $K_a$  = Apparent ionization constants relative to  
the carboxyl groups in the polymer  
 $pK_a$  =  $-\log K_a$   
 $n$  = parameter related to the extension of the polymer  
chain, approaching the higher value with  
increasing dilution, approaching the lower value  
at high ionic strengths. For example, for  
poly(acrylic acid) titrated with sodium hydroxide  
 $n$  is approximately equal to 2.<sup>53</sup>

Addition of neutral salts causes major changes in the titration behavior of poly(acrylic acid). Addition of 0.01N neutral salt lowers the pH values of the titration curve, sharpens the end-point break, and increases the apparent acid strength. Neutral salt causes the increase in acid strength by decreasing the thickness of the ionic double layer around the ionized carboxyls. Apparent ion binding occurs because the strong electrostatic forces surrounding a polymeric chain bearing ionized carboxyl groups cause small positive ions to spend much of their time close to or bound to the polymeric anion. Ion binding increases with extent of ionization, increased valence of cation, decreased size of cation, and increased acid strength of the ionizable groups on the polymer chain. In the series of alkali metals, binding to poly(acrylic acid) decreases in the order  $Li > Na > K > Rb$ .<sup>48</sup> Apparent ion binding is greater the stronger the ionizable acid group on the polymer.

### C. General Analysis Procedure

The aim or objective for the experimental analytical tests were (1) to identify the various constituents (organic and inorganic) of the substances that made up the material composition and (2) to determine the relative quality of the material, that is purity determination and others by wet (molarity, concentration, etc.) and instrumental methods (x-ray diffraction, spectrophotometer (uv/vis, I.R.)).

In the synthesis or attempted synthesis of the materials - Cu(I)PA and Cu(II)(PA)<sub>2</sub> the chosen technique was that of displacement since it not only fulfills our aims but also the method is simple, rapid and easily reproducible.

For the attempted preparation of Cu(I)PA, PAH in aqueous solution (from Scientific Polymer Products, Inc.) and Cu<sub>2</sub>O (from Fisher Scientific Co.) were used. All other materials (KH phthalate, NaOH, 12M HCl) used were obtained from the chemistry stockroom. All the solutions were prepared specifically for this work except for 12M HCl and liquid PAH solution. The KH phthalate was titrated with NaOH to determine the concentration or molarity of NaOH. Then the standard NaOH was titrated with 12M HCl to determine the molarity of HCl and therefore the volume needed to react with Cu<sub>2</sub>O to produce the intermediate (CuCl<sub>2</sub>)<sup>-1</sup>. The NaOH was also titrated with PAH (both solution and powder dissolved to make solution) to determine the molarity of PAH and therefore the amount of PAH that will react with (CuCl<sub>2</sub>)<sup>-1</sup> to produce Cu(I)PA. This was determined from the plot of pH vs. volume NaOH (see Fig. 2a). The sample was analyzed by x-ray diffraction to determine if the sample is crystalline or amorphous, and if crystalline, what compounds were present.

For preparation of  $\text{Cu}(\text{PA})_2$ , the powder PAH used was obtained from Scientific Polymer Products Inc. (See page 20) The standard NaOH solution used was obtained from Fisher Scientific Co. The anhydrous  $\text{CuCl}_2$  was obtained from Aldrich Chemical Co. No further purification was done on any of the material. They were all used as received. 0.8900g PAH (powder) was dissolved in 25.00 mL. distilled  $\text{H}_2\text{O}$ , and stirred till a homogeneous solution was obtained. This viscous slurry-like solution was titrated with 0.1000 N NaOH from Fisher Scientific Co. so as (1) to locate the inflection point (end point, maximum slope point) in the classical S-shaped titration curve (a plot of pH vs. the volume of the titrant dispensed). The volume of titrant dispensed up to the end point was taken to be the sample equivalent volume from which the concentration of sample species were calculated. (see Fig. 2b and 2c); (2) to determine  $\text{Na}^+$  needed or required to replace  $\text{H}^+$  (3) to determine the exact amount of each PAH and NaOH that will react to give an intermediate sodium polyacrylate,



(4) to obtain a clear and less viscous PANA solution.

(5) to theoretically determine or calculate the amount of  $\text{CuCl}_2$  needed to react with sodium polyacrylate for precipitation of copper polyacrylate  $\text{Cu}(\text{PA})_2$  desired.

The solution was stirred and a precipitate which formed was then left to settle for about two hours and filtered through a Gooch crucible. The filtrate was analyzed by gravimetric method ( $\text{Ag}^+ + \text{Cl}^- \longrightarrow \text{AgCl}$ ) to determine the % chloride in the filtrate with the precipitate dried for

118 hours at 110°C. The dried material was reduced in a Parr bomb with 100% hydrogen gas. The reduce sample was then analyzed by x-ray diffraction. The reduced sample was further analyzed with a UV/VIS diffuse reflectance spectrophotometer.

i Copper (I) Polyacrylate:

a. Attempted Preparation of Cu(I)PA: Initially, we planned to prepare cuprous polyacrylate, Cu(I)PA with subsequent partial oxidation of cuprous (+1) in the salt to cupric (+2). A standard solution of sodium hydroxide (NaOH) was first prepared by titration against potassium acid phthalate ( $\text{KHC}_8\text{H}_4\text{O}_4$ ) as primary standard. Standard NaOH was then used to standardize a solution of hydrochloric acid (HCl). Then a calculated stoichiometric volume of the standardized HCl solution (with a large excess of HCl such that the HCl:Cu ratio was 16.9 - see page 33) was poured into a 500 mL, three-neck, round bottom flask and swirled with a magnetic stirrer. Argon (to displace air) was passed into the HCl solution. Also, at the same time, argon gas was also passed into a stoichiometric quantity of 0.1552N poly (acrylic acid) solution (PAH, MW. 250,000 from Aldrich Chemicals) in another flask. A weighed stoichiometric quantity of  $\text{Cu}_2\text{O}$  was poured into the HCl solution (excess HCl, as stated above) and stirred for 15 minutes. The light yellow solution  $(\text{CuCl}_2)^{-1}$  turned colorless upon addition of poly (acrylic acid) solution. The solution  $(\text{CuCl}_2)^{-1} + \text{PAH}$  was heated with a heating mantle. At a temperature between 96°C-98°C, white fumes, presumably of HCl, were given off. After 15 minutes of heating, boiling began and the solution turned yellow. The solution turned darker

as distillation increased. The heating mantle was removed when the solution was close to total evaporation as a slurry with a brownish-gray color. X-ray diffraction patterns (see table I) showed the presence of crystalline  $\text{CuCl}$  and  $\text{CuCl}_2 \cdot 2\text{H}_2\text{O}$ . The attempted reactions were:

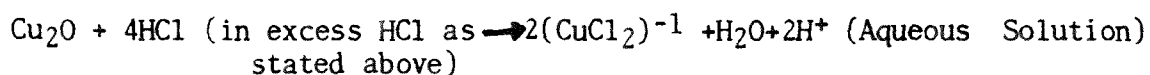

and

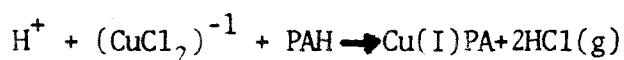

b. Standardization: In order to determine the relative strength of sodium hydroxide ( $\text{NaOH}$ ) and hydrochloric acid ( $\text{HCl}$ ), potassium hydrogen phthalate ( $\text{KHC}_8\text{H}_4\text{O}_4$ ) was weighed out and a solution prepared and titrated with prepared (theoretically calculated) sodium hydroxide solution, to determine the molarity of sodium hydroxide. Then  $\text{NaOH}$  solution was titrated with  $\text{HCl}$  to determine the molarity of  $\text{HCl}$ .

$\text{KHC}_8\text{H}_4\text{O}_4$  is an acid salt which is a non-hygroscopic crystalline solid with a high equivalent weight, a hydrogen containing substance that dissociates into hydrogen ions and anions when dissolved in water.  $\text{NaOH}$ , on the other hand, gives hydroxyl ions and cations upon the same treatment. Thus, by titrating  $\text{KHC}_8\text{H}_4\text{O}_4$  with  $\text{NaOH}$  in aqueous solution, it is easy to determine the concentration of one relative to the other.

#### 1. Preparation of potassium hydrogen phthalate

##### $\text{KHC}_8\text{H}_4\text{O}_4$ solution.

Since  $\text{KHC}_8\text{H}_4\text{O}_4$  is non-hygroscopic, the molarity (M) was used as the basis for the preparation of the solution (with regard to the composition of the solute).

Between 0.8000g and 0.9000g of sample were weighed into 150 mL Erlenmeyer flasks and dissolved in 25.00 mL of distilled water. The preparations were based on the calculations as outlined below:

$$M = \frac{(\text{g solute}) (1000)\text{mL/L}}{(\text{mL. of Soln}) (\text{gmw})}$$

$$1.1 \quad \frac{(0.8258\text{g}) (1000)}{(25.00 \text{ mL}) (204.338 \text{ g/mole})} = 0.1617\text{M}$$

$$1.2 \quad \frac{(0.8220\text{g}) (1000)}{(25.00\text{mL}) (204.338 \text{ g/mole})} = 0.1609\text{M}$$

$$1.3 \quad \frac{(0.8086\text{g}) (1000)}{(25.00 \text{ mL}) (204.338 \text{ g/mole})} = 0.1583\text{M}$$

2. Standardization of NaOH solution from primary KH phthalate standard

The three weighed samples of  $\text{KHC}_8\text{H}_4\text{O}_4$  (0.8258g, 0.8220g, 0.8086g) were transferred into 150 mL. Erlenmeyer flasks and dissolved in 25.00 mL of distilled water. Two drops of phenolphthalein indicator were added to each flask and then titrated with NaOH to the first pink color that persisted for a half minute.

From the formula (stoichiometric).

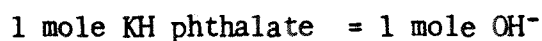

$$\text{Acid} = \text{Base}$$

$$M_1 V_1 = M_2 V_2$$

$$M_2 = \frac{M_1 V_1}{V_2} \quad \text{where } V_1 = 25.00 \text{ mL}$$

$$(1) \frac{(0.1617M) (25.00mL)}{16.60 \text{ mL}} = 0.2435M$$

$$(2) \frac{(0.1690M) (25.00mL)}{16.30 \text{ mL}} = 0.2468M$$

$$(3) \frac{(0.1583) (25.00 \text{ mL})}{16.00 \text{ mL}} = 0.2473M$$

<u>(g) KHC<sub>8</sub>H<sub>4</sub>O<sub>4</sub></u>	<u>Moles KHC<sub>8</sub>H<sub>4</sub>O<sub>4</sub></u>	<u>M KHC<sub>8</sub>H<sub>4</sub>O<sub>4</sub></u>	<u>Vol.(mL) NaOH Used for Titration</u>	<u>M NaOH</u>
0.8258	0.004000	0.1617	16.60	0.2435
0.8220	0.004000	0.1609	16.30	0.2468
0.8086	0.004000	0.1583	16.00	0.2473

$$\text{Average M NaOH} = 0.2459$$

### 3. Standardization of HCl Solution:

500 mL of conc HCl (12M) solution (M) was diluted to 1000 mL in a volumetric flask.

The prepared HCl solution was titrated with standardized NaOH solution to get the concentration of H<sup>+</sup> (HCl).

<u>Vol. HCl (mL)</u>	<u>Vol. NaOH (mL)</u>	<u>M NaOH</u>
1.000	27.20	0.2459
1.000	27.10	0.2459

$$\text{Moles HCl (acid)} = \text{Moles NaOH (base)}$$

$$M_1 V_1 = M_2 V_2$$

$$M_1 = M_2 V_2 \text{ where } V_1 = 1.000 \text{ mL}$$

$$\frac{(27.20 \text{ mL}) (0.2459 \text{ M})}{1.000} = 6.688 \text{ M HCl}$$

$$\frac{(27.10 \text{ mL}) (0.2459 \text{ M})}{1.000} = 6.664 \text{ M HCl}$$

$$\text{Average concentration} = \frac{6.688 + 6.664}{2} = 6.676 \text{ M HCl}$$

Two  $\text{Cu}_2\text{O}$  samples were weighed and dissolved in 10.30 mL and 9.90 mL of 6.676 M solution respectively.

<u>Mass <math>\text{Cu}_2\text{O}</math> (g)</u>	<u>Vol. 6.676 M HCl (mL)</u>
0.2902	10.30
0.2801	9.900
Av. Mass $\text{Cu}_2\text{O}$ =	$\frac{0.2902 \text{ g} + 0.2801 \text{ g}}{2}$
=	0.2852 g
Av. Vol. HCl =	$\frac{10.30 \text{ mL} + 9.900 \text{ mL}}{2}$
=	10.10 mL

$$(1) \text{ mole HCl: } (6.676 \text{ M}) (0.0101 \text{ L}) = 0.0674 \text{ mole HCl solution}$$

$$(2) \text{ mole Cu}_2\text{O: } \frac{0.2852 \text{ g Cu}_2\text{O}}{143.08 \text{ g Cu}_2\text{O/mole}} = 0.001993 \text{ mole Cu}_2\text{O}$$

$$(3) \text{ mole Cu}^{\text{I}}: 2 \times \text{mole Cu}_2\text{O} = 0.003986 \text{ mole Cu}^{\text{I}}$$

$$(4) \text{ M Cu}^{\text{I}}: \frac{0.003986 \text{ moles Cu}^{\text{I}}}{0.0101 \text{ L}} = 0.3947 \text{ M Cu}^{\text{I}}$$

$$(5) \text{ Molar Ratio of HCl:Cu}^{\text{I}}$$

$$\frac{0.0674 \text{ Mole HCl solution}}{0.003986 \text{ mole Cu}_2\text{O}} = 16.9$$



4. Standardization of PAH solution: 18 g of aqueous solution of polyacrylic acid (PAH) obtained from Scientific Polymer Products, Inc. was diluted to 1000 mL with distilled water in a volumetric flask. With a pipet, 25.00 mL of the clear solution was titrated with a previously standardized 0.2459M NaOH solution to calculate the concentration of H<sup>+</sup> (PAH content). From Fig. 2a, the equivalence point shows that 14.05 mL of 0.2459M NaOH was used.

$$\text{Since } M_1V_1 \text{ (Acid)} = M_2V_2 \text{ (base)}$$

$$M \text{ PAH} = \frac{(0.2459 \text{ M}) (14.05 \text{ mL})}{25.0 \text{ mL}} = 0.1382 \text{ M}$$

(0.1382 M PAH) (0.02500 L) =  $3.46 \times 10^{-3}$  moles PAH in 25.00 mL PAH solution. This would require 0.00346 mole Cu<sup>I</sup>

$$\text{Needed } \frac{0.00346}{2} = 0.00173 \text{ moles Cu}_2\text{O}$$



$$\begin{aligned} 0.00173 \text{ mole Cu}_2\text{O} \times 143.08 \text{ Cu}_2\text{O/mole} \\ = 0.2475 \text{ g Cu}_2\text{O} \end{aligned}$$

$$\frac{0.2475 \text{ g}}{143.08 \text{ g/mole}} = 1.73 \times 10^{-3} \text{ moles Cu}_2\text{O}$$

$$\begin{aligned} &= 0.00346 \text{ moles Cu}^{\text{I}} \\ (6.676 \text{ mole HCl/L}) (0.0101 \text{ L}) &= 6.743 \times 10^{-2} \text{ moles HCl} \end{aligned}$$

$$\text{mole ratio} = \frac{\text{mole Cl}^-}{\text{mole Cu}^{\text{I}}} = \frac{0.06743}{0.00346}$$

$$= 19.49 \text{ (Mole ratio Cl}^-/\text{Cu}^{\text{I}} +1)$$

therefore, dissolve 0.2475 g Cu<sub>2</sub>O in

$$\frac{(0.00346 \text{ mole Cu}^{\text{I}}) (19.49)}{6.676 \text{ mole HCl/L}}$$

$$= 0.01010 \text{ L} = 10.10 \text{ mL of } 6.676 \text{ M HCL}$$

C. X-Ray Diffraction: X-ray diffraction powder patterns were obtained by using a Norelco instrument with 57.3 mm radius powder cameras.

The diffraction patterns of standard materials (obtained from the JCPD's powder diffraction file) and the prepared sample are given in Table I).

As can be seen from the table, the product obtained is composed of CuCl and  $\text{CuCl}_2 \cdot 2\text{H}_2\text{O}$ . Although Cu(I)PA might be amorphous, presence of CuCl indicates we did not have  $\text{Cu}^{\text{I}}\text{PA}$  (shown below).

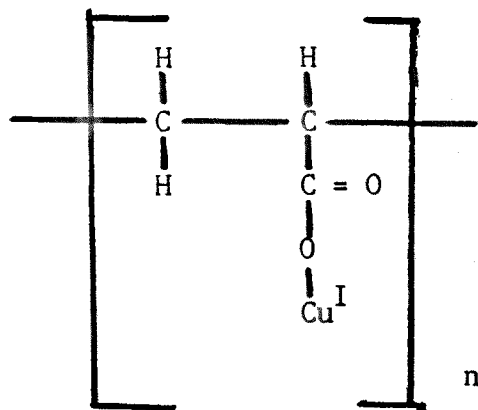

TABLE 1

X-Ray Diffraction Powder Patterns

Cu (4-0836)		Cu <sub>2</sub> O (5-0667)		CuCl (6-0344)		CuCl <sub>2</sub> ·2H <sub>2</sub> O (13-145)		Sample Cu <sup>I</sup> PA (attempted)	
d(Å)	I/I <sub>1</sub>	d(Å)	I/I <sub>1</sub>	d(Å)	I/I <sub>1</sub>	d(Å)	I/I <sub>1</sub>	d(Å)	
2.088	100	3.020	9	3.127	100	5.44	100	5.4	Medium
1.808	46	2.465	100	2.710	8	4.02	14	4.1	Weak
1.278	20	2.135	37	1.915	55	3.72	2	3.13	Very Strong
1.0900	17	1.743	1	1.633	32	3.69	2	2.75	Weak
1.0436	5	1.510	27	1.354	6	3.32	2	2.64	Weak +
0.9038	3	1.287	17	1.243	9	3.07	4	2.22	Very Weak
0.8298	9	1.233	4	1.1054	8	2.735	2	2.11	Very Weak
0.8083	8	1.0674	2	1.0422	5	2.637	10	2.01	Very Weak
		0.9795	4	0.9574	2	2.577	2	1.92	Strong
		0.9548	3	0.9154	4	2.536	6	1.64	Strong
		0.8715	3	0.8564	3	2.365	4	1.36	Medium
		0.8216	3			2.211	4	1.25	Medium
						2.099	4	1.11	Medium +
						2.066	6	1.05	Medium
						2.000	2		

ii Copper II Polyacrylate

a. Preparation of  $\text{Cu}(\text{PA})_2$ : Because  $\text{Cu}^{\text{I}}\text{PA}$  did not form we went to cupric polyacrylate ( $\text{Cu}^{\text{II}}(\text{PA})_2$ ). This precipitated as a result of crosslinking.

Weighed samples of polyacrylic acid were each dissolved in distilled water to give a theoretical calculated polyacrylic acid concentration. The solution was then titrated against 0.2500M NaOH solution (from Fisher Scientific Co.) to give actual experimental concentration. The pH readings were plotted against the volume of NaOH solution used (Figs. 2b and 2c).

A series of copper (II) polyacrylate salts were prepared. The stoichiometric ratios of the reactions varied between 1:3 to 3:1. The ratio of aqueous solution  $\text{PAH} + \text{NaOH} \rightarrow \text{PANa} + \text{H}_2\text{O}$  were varied. Also the aqueous  $\text{CuCl}_2$  solution was varied relative to sodium polyacrylate solutions, to give the precipitation desired, that is



b. Polyacrylic Acid and Sodium Polyacrylate Solutions:

Preceding the preparation of solutions for precipitation, a PAH sample (M.W. 750,000 from B.F. Goodrich, via Scientific Polymer Products, Inc. (Cat. #597)) solution, prepared from theoretical calculated concentration, was titrated with 0.2500 M NaOH (from Fisher Scientific) to get the concentration of  $\text{H}^+$ . It was also found that PANa had lower viscosity and is clearer than a PAH solution.

Therefore, PANa solution was used for the precipitation of  $\text{Cu}(\text{PA})_2$ . The reactions were expected to be:

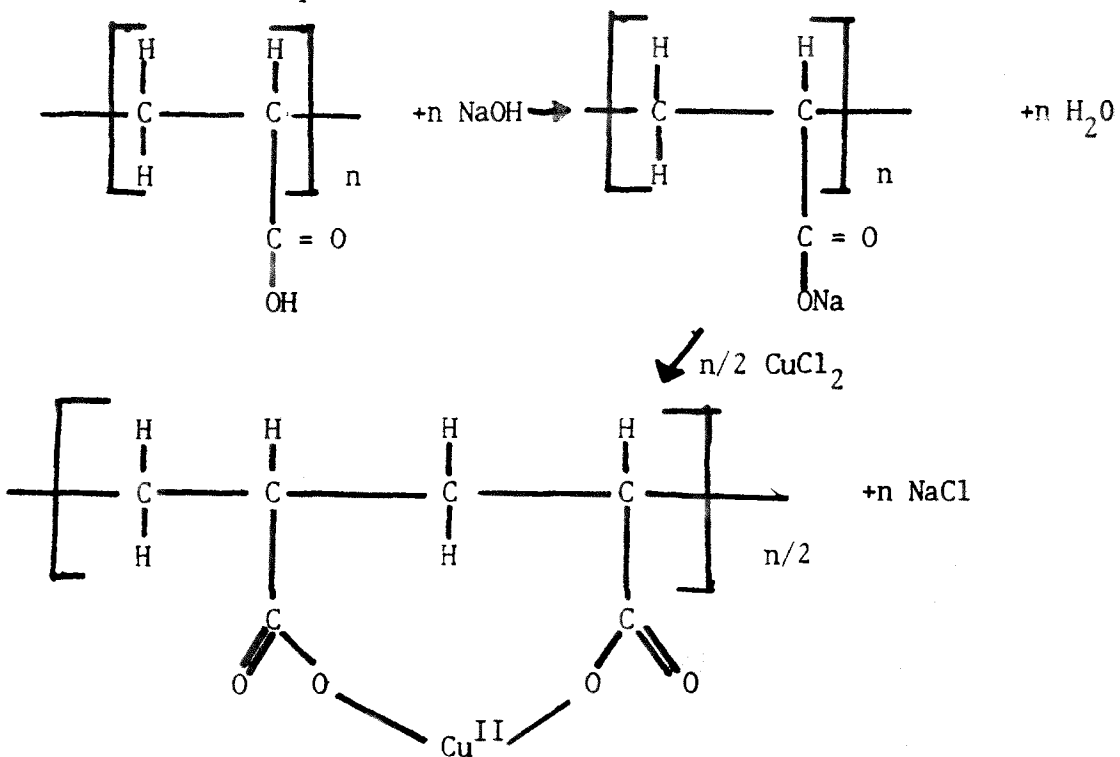

(or some other intramolecular substitution of  $\text{Cu}^{2+}$  for  $2\text{H}^+$  wherein non-adjacent  $\text{H}^+$  ions are replaced by  $\text{Cu}^{2+}$  ions within a polymer molecules); or a crosslinked equivalent of this:

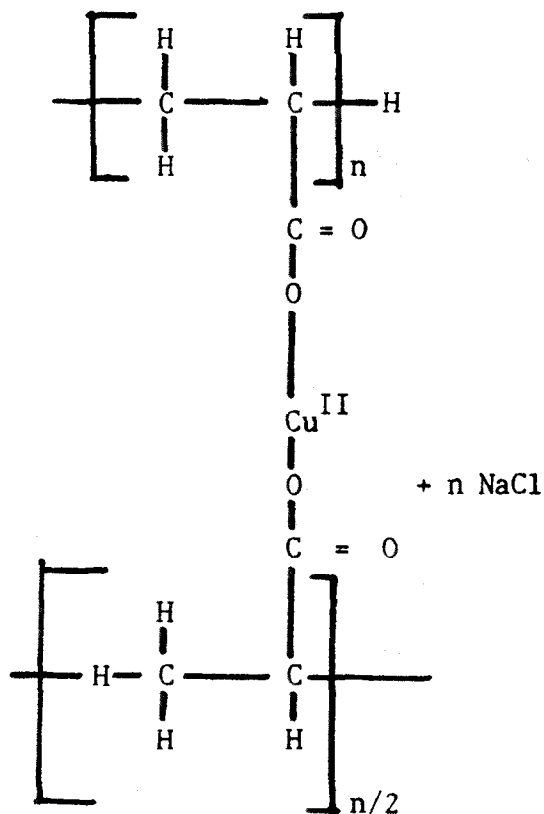

From Fig. 2b and 2c:

$$(1) \frac{(53.50 \text{ mL NaOH}) (0.2500 \text{ M NaOH})}{56.00 \text{ mL PAH}} = 0.2388 \text{ M}$$

$$(2) \frac{(52.50 \text{ mL NaOH}) (0.2500 \text{ M NaOH})}{55.30 \text{ mL PAH}} = 0.2373 \text{ M}$$

$$Av = \frac{(0.2388 + 0.2373)}{2} = 0.2381 \text{ M}$$

2

From the calculation of acidity from Figs. 2b and 2c, we found lower acidity (0.2381 M) than expected compared to the theoretical PAH solution concentration (0.2500 M) prepared due to higher equivalent weight of 76, rather than 72 (calculated experimental equivalent weight is 75.6). This correlates to Goodrich equivalent weight for Carbopol 910 used in the synthesis.

c. CuCl<sub>2</sub>: Since we needed a stoichiometric amount of each material for the synthesis of cupric polyacrylate, the amount and concentration of CuCl<sub>2</sub> solution needed (Table 2) to react with polyacrylic acid was determined as follows:

A weighed quantity of anhydrous CuCl<sub>2</sub> (33.625g) was dissolved in water to make 1L solution, but was slightly cloudy and was therefore filtered. The filtrate was poured into a volumetric flask and diluted to approximately 500 mL or 1000 mL (as indicated in Table 4).

Four 10.00 mL portions of the solution were treated with KI (3 g KI dissolved in 10.00 mL H<sub>2</sub>O) solution. Starch was added and then titrated against 0.1000 M sodium thiosulfate solution (Na<sub>2</sub>S<sub>2</sub>O<sub>3</sub> solution from Fisher Scientific) as outlined below:

- 1) 0.2500 M CuCl<sub>2</sub> was prepared by dissolving 33.625g CuCl<sub>2</sub> in H<sub>2</sub>O to make 1L solution.
- 2) Solution was filtered.
- 3) Filterate rediluted.
- 4) 10.00 mL solution was pipetted into 250 mL Erlenmeyer flask.
- 5) Conc. NH<sub>3</sub> solution added drop by drop until the whitish Cu(OH)<sub>2</sub> first formed starts to dissolve (indicated by the formation of the dark blue complex Cu (NH<sub>3</sub>)<sup>2+</sup> (approximately two drops).  
$$\text{Cu}^{+2} + 2\text{OH}^{-} \longrightarrow \text{Cu(OH)}_2 \xrightarrow{2\text{NH}_3} \text{Cu(NH}_3)_2^{2+} + 2\text{OH}^{-}$$
- 6) Added 0.5 mL (approximately 10 drops) glacial acetic acid.
- 7) Diluted to 100 mL.
- 8) Added 3g KI dissolved in 10 mL H<sub>2</sub>O.
- 9) Turned yellow (CuI + I<sub>2</sub> formed).
- 10) Added 1 mL starch solution; solution turned dark blue.
- 11) Added additional 1 mL starch solution.
- 12) Titrated solution against 0.1000 M sodium thiosulfate (from Fisher Scientific) until the dark blue color disappears permanently.

The reaction occurring on titration is:

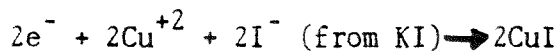

Before titration



During titration

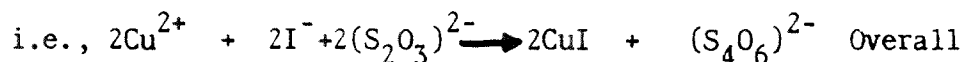
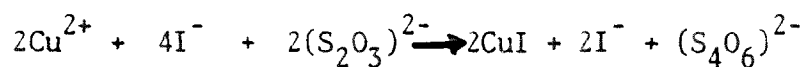
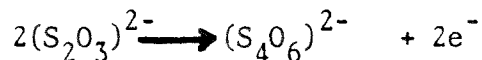
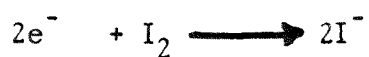

Titration with standard  $Na_2S_2O_3$  solution yields amount  $I_2$  which gives amount of  $Cu^{+2}$

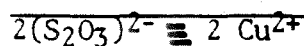
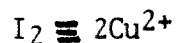
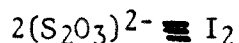

i.e. 1 mole  $(S_2O_3)^{2-} \equiv 1$  mole  $Cu^{+2}$ .

Four 10.00 mL samples of 0.2500 M  $CuCl_2$  solution (theoretically calculated) were titrated against 0.1000  $Na_2S_2O_3$  as outlined in step 11 above.

<u>CuCl<sub>2</sub> (mL)</u>	<u>Na<sub>2</sub>S<sub>2</sub>O<sub>3</sub> (mL)</u>
10.00	15.90
10.00	15.50
10.00	15.85
10.00	15.70
Average = 15.74 mL	<u>62.95</u>



$$M_1 V_1 = M_2 V_2$$

$$(M_1) (10.00 \text{ mL}) = (15.74 \text{ mL}) (0.1000\text{M})$$

$$M_1 = \frac{(15.74 \text{ mL}) (0.1000\text{M})}{10.00 \text{ mL}} = 0.1574 \text{ M CuCl}_2 \text{ Solution}$$

d. Preparation of Aqueous Solution: Solutions of NaOH- neutralized polymer of concentration required for precipitation at a given degree of neutralization and ionic strength of added salt ( $\text{CuCl}_2$ ) was prepared as follows: A weighed quantity of the polymer sample, previously titrated for normality (PAH content) was introduced into a 250 mL volumetric flask, water added from a buret in the precise aqueous concentration required. Aqueous sodium hydroxide was added from a buret in the precise proportion required for the desired degree of neutralization and the mixture was then stirred for five minutes. Copper (II) chloride solution (previously prepared and titrated against a standard  $\text{Na}_2\text{S}_2\text{O}_3$  solution) was added in the precise proportion required for degree of precipitation, to the continuously stirred aqueous solution (PAH + NaOH) and stirred further for another five minutes with a magnetic stirrer (Table 2). The mixed solutions resulted in a blue precipitate, and the mixture was then allowed to stand overnight. The precipitate was filtered through a Gooch crucible with vacuum, and the filtrate was analyzed by the iodometric method (Tables 4 and 5). The solid precipitate was dried in a Fisher Isotemp oven at  $110^\circ\text{C}$  for about eight days to constant weight (Table 3), and the theoretical and actual yields were compared (Table 6).

TABLE 2

Amount of Reactants Used

		Distilled	NaOH (mL)	CuCl <sub>2</sub> (mL)
	<u>PAH (g)</u>	<u>H<sub>2</sub>O (mL)</u>	<u>(0.2500M)</u>	<u>(0.1574M)</u>
1.	1Cu:2PAH			
	A	0.9036	50.20	47.80
	B	0.8998	49.90	41.50
	C	0.9037	50.20	47.80
				40.00
				37.70
				40.00
2.	1Cu:1PAH			
	A	0.8793	48.80	46.50
	B	0.9023	50.10	47.70
	C	0.9034	50.10	47.70
				73.80
				75.80
				75.80
3.	1Cu:3PAH	Too viscous, cannot be filtered through the Gooch crucible, hence no data.		
4.	2Cu:1PAH			
	A	0.4497	25.00	23.80
	B	0.4518	25.10	23.90
	C	0.4512	25.00	23.80
				75.60
				75.90
				75.60
5.	3Cu:1PAH			
	A	0.4529	25.10	23.90
	B	0.4508	25.00	23.80
	C	0.4514	25.10	23.90
				113.90
				113.50
				113.90

TABLE 3

Masses of Copper Polyacrylate Salts Obtained

		<u>Crucible (g)</u>	<u>Crucible and Sample (g)</u>	<u>Product (g)</u>	<u>Color</u>
1.	1Cu:2PAH				
	A	23.8414	25.1538	1.3124	Dark Blue & Light Blue Portions
	B	24.1093	25.3948	1.2855	"
	C	24.0076	25.3120	1.3044	"
2.	1Cu:1PAH				
	A	23.6762	24.9404	1.2642	"
	B	24.0293	25.3342	1.3049	"
	C	24.2085	25.5621	1.3536	"
3.	2Cu:1PAH				
	A	23.9232	24.5680	0.6448	"
	B	23.9465	24.6002	0.6537	"
	C	23.9894	24.6382	0.6488	"
4.	3Cu:1PAH				
	A	23.7389	24.3965	0.6576	"
	B	23.6110	24.2627	0.6517	"
	C	30.9763	31.6396	0.6633	"

Crucibles and samples were heated in the oven for 189 hours at 110°C.

TABLE 4  
Titration of Aliquots of Filtrates  
with Na<sub>2</sub>S<sub>2</sub>O<sub>3</sub>

	<u>A</u>	<u>B</u>	<u>C</u>	<u>D</u>	<u>E</u>
1. 1Cu:2PAH					
(a)	1001.80	10.00	0.050	5.009 x10 <sup>-2</sup>	6.246
(b)	500.80	10.00	0.10	5.008 x10 <sup>-2</sup>	5.884
(c)	1001.60	10.00	0.050	5.008 x10 <sup>-2</sup>	6.246
2. 1Cu:1PAH					
(a)	1001.80	10.00	5.10	5.11	6.520
(b)	1002.00	10.00	5.10	5.11	6.820
(c)	501.50	10.00	11.10	5.7	6.360
3. 1Cu:3PAH	No filtrate due to high viscosity of the sample. It will not go through the Gooch crucible.				
4. 2Cu:1PAH					
(a)	1003.10	10.00	8.75	8.78	3.120
(b)	502.00	10.00	17.75	8.91	3.040
(c)	501.60	10.00	17.65	8.85	3.050
5. 3Cu:1PAH					
(a)	1003.50	10.00	14.65	14.79	3.230
(b)	501.80	10.00	28.95	14.53	3.330
(c)	501.60	10.00	29.70	14.90	3.030

- A. Volume of filtrate (mL) after separation of Cu polyacrylate precipitate.
- B. Vol. Aliquots (mL)
- C. Vol. 0.1000 M (mL) Na<sub>2</sub>S<sub>2</sub>O<sub>3</sub> used for titration.
- D.  $\mu$ moles Cu in filtrate.
- E.  $\mu$ moles Cu in solid (precipitate) by difference.

e. Comparison of Theoretical Yield and Actual Experimental Yields:

In order to determine the composition, or percentages of Cu that reacted, incorporated, or bound with poly(acrylic acid) to form the Cu(II) polyacrylate salts, the amount of unreacted copper and chloride in the filtrates, were determined by classical wet methods of quantitative analysis as outlined below:

Calculated  $\text{CuCl}_2$  samples were weighed, and the theoretical yields of the salt were calculated according to the method outlined below. Also, the actual experimental yields were calculated after drying in a Gooch crucible to constant weights (Table 6). This table shows that the only product (despite different molar ratios) is  $\text{Cu}(\text{PA})_2$ .

1. Percentages of Copper in Samples and Filtrates

Distilled water was added to the filtrates to volumes as indicated in Table 4. 10.00 mL aliquots were taken and titrated against 0.1000 N  $\text{Na}_2\text{S}_2\text{O}_3$  (from Fisher Scientific) as outlined in the procedure for determining the normality and molarity of  $\text{CuCl}_2$ . Also, percentages of distribution of the initial quantity of copper in precipitates and filtrates were calculated (see Table 5). From Table 5, we can see that the percentage of Cu in precipitate and percent in filtrate shows that the end products regardless of molar ratio is  $\text{Cu}(\text{PA})_2$ .

$$1.1 \quad \frac{\text{mmoles Cu}^{2+}}{\text{mL}} \text{ in solution started with}$$

$$(\text{vol. of CuCl}_2 \text{ solution used}) (\text{M Cu}^{2+})$$

$$\text{i.e., (mL. CuCl}_2 \text{ solution)} \left( \frac{\text{mmoles Cu}^{2+}}{\text{mL}} \right)$$

which gives mmoles  $\text{Cu}^{2+}$

$$1.2 \quad \frac{\text{mmoles Na}_2\text{S}_2\text{O}_3}{2}$$

$$(\text{vol. of Na}_2\text{S}_2\text{O}_3 \text{ used}) (\text{M Na}_2\text{S}_2\text{O}_3)$$

$$\text{i.e., (mL Na}_2\text{S}_2\text{O}_3) \left( \frac{\text{meq}}{\text{mL Na}_2\text{S}_2\text{O}_3} \right)$$

which gives meq  $\text{Cu}^{2+}$ . This is numerically equal to mmoles  $\text{Cu}^{2+}$ .

1 mmole  $\text{Cu}^{2+}$  = 2 meq. for precipitation of  $\text{Cu}(\text{PA})_2$  though only 1 meq. used for titration.

$$1.3 \quad \frac{\text{mmoles Cu}^{2+}}{\text{mL}} \text{ in filtrate}$$

$$\left( \frac{\text{mmoles Na}_2\text{S}_2\text{O}_3}{1000 \text{ mL}} \right) \left( \frac{\text{aliquot mL}}{\text{mL}} \right) (\text{vol. (mL) of filtrates}$$

after separation of Cu polyacrylate precipitate = Y)

$$1.4 \quad \% \text{ Cu in sample} = \frac{\text{mmole Cu in sample} - Y}{\text{mole Cu in sample}}$$

$$1.5 \quad \% \text{ Cu in filtrate} = 100 - \% \text{ Cu in sample.}$$

1 mmole  $\text{Cu}^{2+}$  = 2 meq. for precipitation of  $\text{Cu}(\text{PA})_2$   
though only 1 meq. used for titration.

TABLE 5

Percentage of Copper in Samples and Filtrates

<u>mmoles Cu in Sample</u>	<u>meq. Na<sub>2</sub>S<sub>2</sub>O<sub>3</sub> Used to Titrate Filtrate</u>	<u>mmoles Cu in Filtrate</u>	<u>mmoles Cu in Preci- pitate</u>	<u>Percent Cu in Pre- cipitate</u>	<u>Percent Cu in Fil- trate</u>
1. 1Cu:2PAH					
a) 6.296	0.00500	5.009x10 <sup>-2</sup>	6.246	99.2	0.800
b) 5.934	0.0100	5.008x10 <sup>-2</sup>	5.884	99.2	0.800
c) 6.296	0.00500	5.008x10 <sup>-2</sup>	6.246	99.2	0.800
			Average	<u>99.2</u>	<u>0.800</u>
2. 1Cu:1PAH					
a) 11.629	0.51	5.11	6.520	56.1	43.9
b) 11.930	0.51	5.11	6.820	57.2	42.8
c) 11.930	1.11	5.57	6.360	53.3	46.7
			Average	<u>55.5</u>	<u>44.5</u>
3. 1Cu:3PAH NO DATA (UNFILTERABLE)					
4. 2Cu:1PAH					
a) 11.90	0.875	8.78	3.120	26.20	73.8
b) 11.95	1.775	8.91	3.040	25.40	74.6
c) 11.90	1.765	8.85	3.050	25.60	74.4
			Average	<u>25.73</u>	<u>74.3</u>
5. 3Cu:1PAH					
a) 17.93	1.465	14.70	3.23	18.0	82.0
b) 17.86	2.895	14.53	3.33	18.6	81.4
c) 17.93	2.970	14.90	3.03	16.9	83.1
			Average	<u>17.8</u>	<u>82.2</u>

TABLE 6

Yield Data of Copper PolyacrylateSalts (Precipitates)

	<u>Mole PAH</u>	<u>Mole Salt</u>	<u>Theo- retical Yield (g)</u>	<u>Actual Yield (g)</u>	<u>Yield if Cu(PA)<sub>2</sub> (g)</u>
1.	1Cu:2PAH				
a)	1.254x10 <sup>-2</sup>	6.270x10 <sup>-3</sup>	1.2893	1.3124	1.3124
b)	1.249x10 <sup>-2</sup>	6.245x10 <sup>-3</sup>	1.2840	1.2855	1.2855
c)	1.254x10 <sup>-2</sup>	6.270x10 <sup>-3</sup>	1.2890	1.3044	1.3044
2.	1Cu:1PAH				
a)	1.220x10 <sup>-2</sup>	1.220x10 <sup>-2</sup>	1.6420	1.2642	1.2540
b)	1.252x10 <sup>-2</sup>	1.252x10 <sup>-2</sup>	1.6850	1.3049	1.2870
c)	1.254x10 <sup>-2</sup>	1.254x10 <sup>-2</sup>	1.6870	1.3536	1.2890
3.	1Cu:3PAH - PRECIPITATE UNFILTERABLE				
4.	2Cu:1PAH				
a)	6.241x10 <sup>-3</sup>	6.241x10 <sup>-3</sup>	1.2360	0.6448	0.6420
b)	6.270x10 <sup>-3</sup>	6.270x10 <sup>-3</sup>	1.2420	0.6537	0.6450
c)	6.260x10 <sup>-3</sup>	6.260x10 <sup>-3</sup>	1.2400	0.6488	0.6440
5.	3Cu:1PAH				
a)	6.285x10 <sup>-3</sup>	6.285x10 <sup>-3</sup>	1.6440	0.6576	0.6560
b)	6.253x10 <sup>-3</sup>	6.253x10 <sup>-3</sup>	1.6360	0.6517	0.6430
c)	6.260x10 <sup>-3</sup>	6.260x10 <sup>-3</sup>	1.6370	0.6633	0.6440



2. Percentages of Chloride in Filtrates In order to determine whether some chloride occurs in the Cu(II) polyacrylate salts prepared, the amounts of  $\text{Cl}^-$  in the salt and filtrates are determined as follows:

25.00 mL aliquots were pipetted into volumetric flasks. Five percent silver nitrate solution (prepared from solid purchased from Fisher Scientific Co.) were added. The solution was immediately filtered through a preweighed Gooch crucible. The precipitates were dried for nineteen (19) hours in an oven at  $100^\circ\text{C}$ . The Gooch crucibles were weighed again and weights of AgCl precipitates were calculated (Table 7). From this, the percent  $\text{Cl}^-$  in filtrates were calculated (Table 8).

Since  $\text{mmoles AgCl} = \text{moles Cl}^-$

ie  $\text{AgCl} \rightarrow \text{Ag}^+ + \text{Cl}^-$  (in solution)

$$\frac{(\text{Xg AgCl})}{(\text{M.W. AgCl/mole})} \times \frac{(\text{vol. filtrate})}{(\text{vol. Aliquot})} = J$$

also

$\text{CuCl}_2 \rightarrow \text{Cu}^{+2} + 2\text{Cl}^-$ ; ie 1:2

$\text{mmole Cl}^-$  in sample =  $2x$  mole  $\text{Cu}^{+2}$  in sample = P

$$\% \text{ Cl in filtrate} = \frac{J}{P} \times 100$$

ie  $\text{CuCl}_2 + 2 \text{AgNO}_3 \rightarrow 2 \text{AgCl} + \text{Cu}(\text{NO}_3)_2$

where  $J = \text{mmoles Cl}^-$  in filtrate

$P = \text{mmoles Cl}^-$  in sample

TABLE 7

Masses of Chloride in Filtrate

	<u>Crucible (g)</u>	<u>Crucible + AgCl (g)</u>	<u>AgCl (g)</u>	<u>Mass of Cl<sup>-</sup> (g)</u>
1.	1Cu:2PAH			
a)	31.0662	31.1121	0.0459	0.0114
b)	24.1093	24.2030	0.0937	0.0232
c)	24.0076	24.0556	0.0480	0.0119
2.	1Cu:1PAH			
a)	23.6762	23.7670	0.0908	0.0225
b)	24.0293	24.1178	0.0885	0.0219
c)	24.2085	24.3782	0.1697	0.0420
3.	2Cu:1PAH			
a)	23.9232	24.0155	0.0923	0.0228
b)	23.9465	24.1204	0.1739	0.0431
c)	23.9894	24.1628	0.1734	0.0439
4.	3Cu:1PAH			
a)	23.7389	23.8786	0.1397	0.0346
b)	23.6110	23.8685	0.2575	0.0847
c)	30.9763	31.2517	0.2754	0.0682

N.B.: The silver chloride (AgCl) precipitates were dried  
in an oven for nineteen (19) hours at 110°C.

TABLE 8

Percentage of Chloride (Cl<sup>-</sup>) In Filtrates

<u>mmole in Sample</u>	<u>mmole AgCl in 25.00 mL Filtrate</u>	<u>mmole (Cl<sup>-</sup>) in Entire Filtrate</u>	<u>% Cl<sup>-</sup> in Filtrate</u>
1. 1Cu:2PAH			
a) 12.59	$3.203 \times 10^{-1}$	12.84	102.0
b) 11.87	$6.538 \times 10^{-1}$	13.10	110.4
c) 12.59	$3.349 \times 10^{-1}$	13.42	<u>106.3</u>
		Average	106.3
2. 1Cu:1PAH			
a) 23.24	$6.355 \times 10^{-1}$	25.39	109.3
b) 23.86	$6.175 \times 10^{-1}$	24.75	103.7
c) 23.86	1.184	23.75	<u>100.5</u>
		Average	104.5
3. 1Cu:3PAH	NO DATA, because it is too viscous, will not flow through the Gooch crucible hence no filtrate.		
4. 2Cu:1PAH			
a) 23.80	$6.44 \times 10^{-1}$	25.84	108.6
b) 23.90	1.213	24.36	101.9
c) 23.80	1.210	24.28	<u>102.0</u>
		Average	104.2
5. 3Cu:1PAH			
a) 35.86	$9.747 \times 10^{-1}$	39.12	109.1
b) 35.72	1.800	36.13	101.1
c) 35.86	1.800	36.12	<u>100.7</u>
		Average	103.6

N.B.: The values of chloride in the filtrate over 100% are probably due to experimental error.

F. Reduction of Sample

(1) Ceramic Tube

A ground sample of  $\text{Cu}(\text{PA})_2$  was placed in a porcelain crucible placed in a ceramic tube (see Fig. 3) with air or a mixture of 4% hydrogen and 96% argon, or 100%  $\text{H}_2$  (after first flushing with the gas flowing at room temperature) continuously flowing in during heating. The physical observations are given in Table 9.

SAMPLE REDUCTION IN CERAMIC TUBE

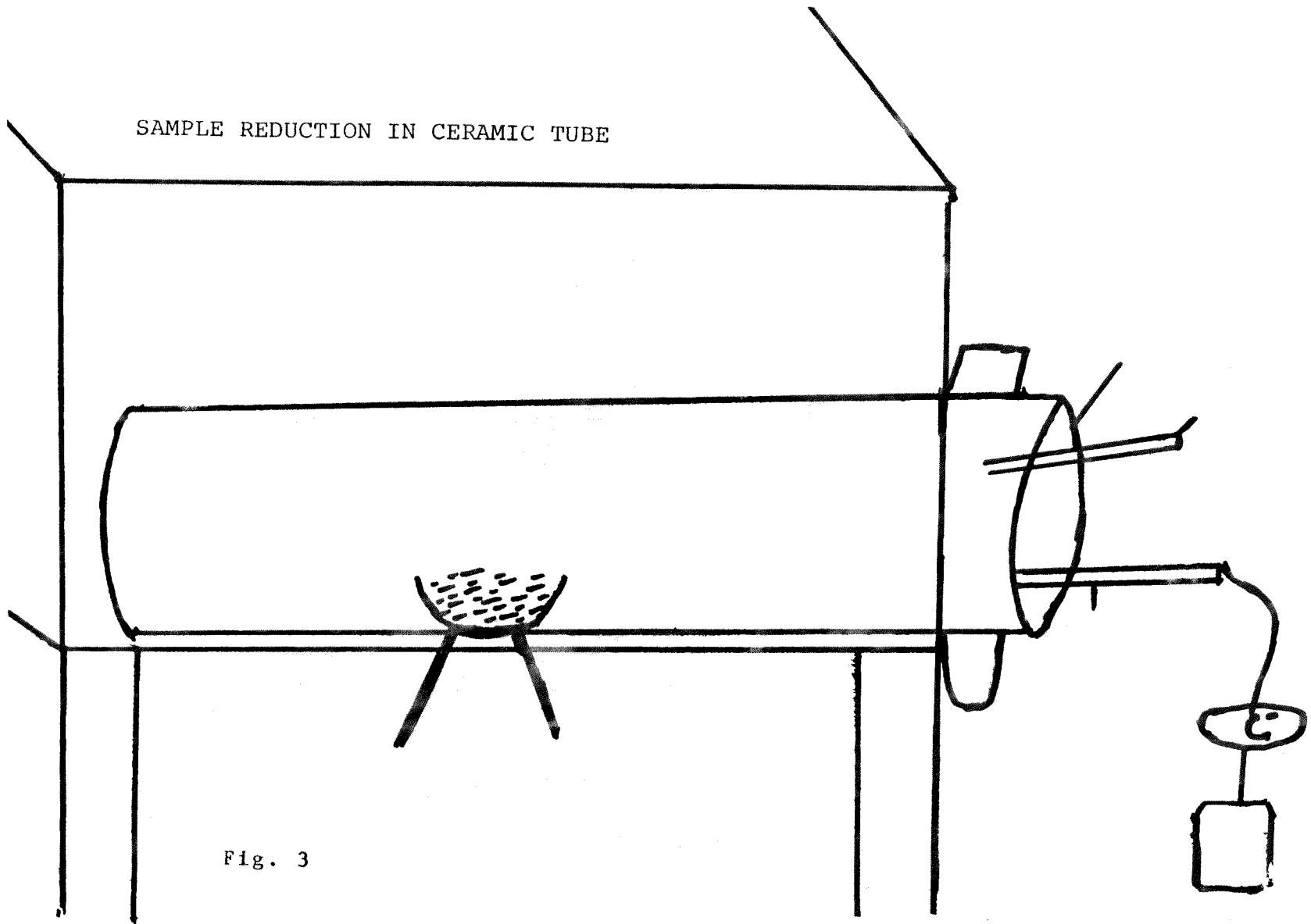

Fig. 3

TABLE 9

Observations of Effect of Temperature and  
Atmosphere on PAH and Copper Polyacrylate Preparations  
(at various atmospheres)

<u>Sample</u>	<u>Muffle Furnace Temp. (°C)</u>	<u>Time (Hours)</u>	<u>Observation</u>
I.     Cu(PA) <sub>2</sub>	heated in air		
	150	1	No change
	200	2	No change
	250	2	Turned black
II.     Polyacrylic acid	heated in air		
	220	1	No change
	250	1	No change
	250	2	Turned yellow
III.    PAH reduced	in flowing 3.59% H <sub>2</sub> + 96.41% Argon (1 atm)		
	150	1	No change
	200	1	No change
	200	2	No change
IV.     Cu(PA) <sub>2</sub>	reduced in 100% H <sub>2</sub> (flowing, 1 atm).		
	150	1	No change
	160	1	Dark brown
	170	1	Dark brown
	200	1	Deep brown

SAMPLE REDUCTION IN PARR BOMB

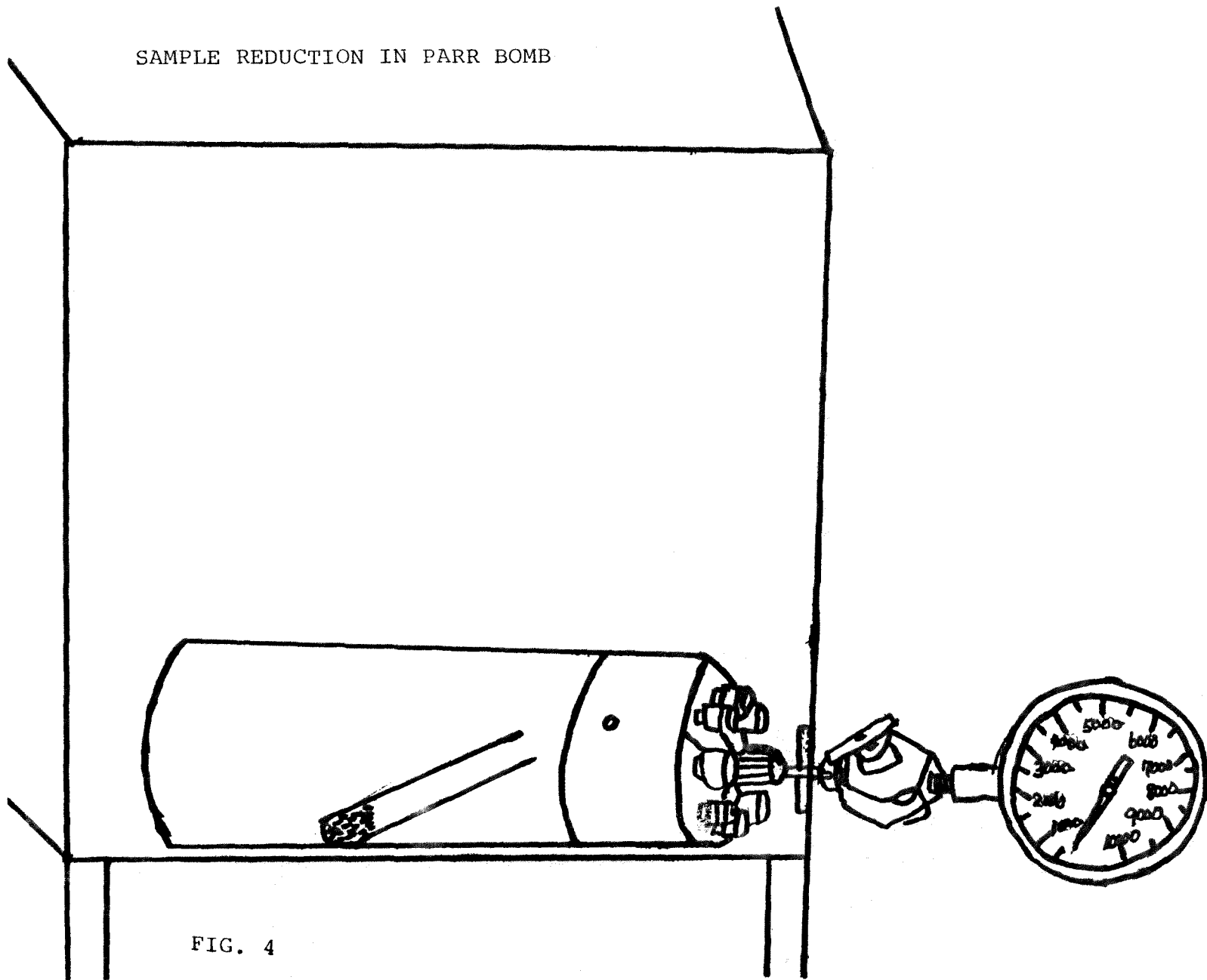

FIG. 4

## 2. Parr Bomb

A ground sample of  $\text{Cu}(\text{PA})_2$  was placed in a test tube and placed in a Parr bomb (Fig. 4), which was then flushed several times with pure hydrogen. Then pure  $\text{H}_2$  gas was admitted to yield pressures desired at required temperatures (see Table 9). The Parr bomb was then put into a muffle furnace with the gauge outside, as shown in Fig. 4, and the temperature of the bomb read from a mounted thermocouple. For reaction at  $25^\circ\text{C}$ , the Parr bomb was left on the lab bench for about ten days (Table 10).

Samples were reduced in a Parr bomb at calculated temperature and pressure.

From gas law

$$PV = n RT$$

$$n = \frac{PV}{RT}$$

since  $n$  (moles),  $V$  (volume of the Parr bomb) and  $R$  (gas constant) are constants.

$$\frac{P}{T} = K$$

Experimental = Standard (room temp.) ( $25^\circ\text{C}$ )

$$P_1/T_1 = P_2/T_2$$

$$P_2 = \frac{(\text{experimental temp.}) \times (\text{pressure at room temp.})}{\text{room temp.}}$$

$$\text{i.e., } P_2 = \frac{T_2}{298} \times P_1$$

$$P_1 = (P_2 \times 298) / T_2$$



where  $P_1$  = Pressure at room temp.

$T_2$  = Experimental temp.

$P_2$  = Experimental pressure at experimental temp.

Reductions were carried out with results shown in Table 10.

TABLE 10

Sample Reduction in a Parr Bomb (in 100%  $H_2$ )

<u>Sample</u>	<u><math>P_1</math>(atm.)</u>	<u><math>P_2</math>(atm.)</u>	<u>Temp. °C</u>	<u>Time</u>	<u>Observation</u>
$Cu(PA)_2$	180	180	25	10 Days	Black
$Cu(PA)_2$	156	180	71	2-4 Hrs.	Copper brown
$Cu(PA)_2$	147	180	91	2-4 Hrs.	Copper brown

Reductions were carried out in a Parr bomb at high  $H_2$  pressure.

g. Electrical Measurements

The resistivity of intrinsic semiconductors (and of extrinsic semiconductors until depletion of electrons or holes) decreases as the temperature increases. In pure inorganic semiconductors, this is due to the fact that thermal excitation releases electrons from interatomic bonds and application of an electric field enables the released electrons to move through the solid. Each sample was pressed into a pellet in a 1/4" diameter cylindrical die with a Carver hydraulic press at 2,200 pounds force which corresponds to 44,000 pounds per square inch or 3,000 atm. pressure. It was then assembled between gold-plated brass electrodes inside a glass tube. Electrical contact was assured by applying a slight pressure by means of steel springs on the contact electrodes. The resistance was read directly from a Keithley Model 616 digital electrometer, which had been checked against standard resistors ( $10^{10}$  and  $10^{11}$  ohm-cm) (See Tables 11 and 12).

TABLE 11

Resistivities of Samples Heated or  
Reduced in the Ceramic Tube

$$\rho = R / \left( \pi \left( \frac{D}{4} \right)^2 / t \right) = R \left( \frac{0.3167}{t} \right)$$

$\rho$  = Specific Resistivities  
D = diameter of the sample  
R = resistance of the sample  
t = sample's thickness

<u>Samples (all Cu(PA)<sub>2</sub>)</u>	<u>Thickness</u> <u>(cm)</u>	<u>R</u> <u>(ohms)</u>	<u><math>\rho</math></u> <u>ohm-cm</u>
Pure	0.665	1.410x10 <sup>12</sup>	6.715x10 <sup>11</sup>
Heated in air at 250°C	1.948	2.510x10 <sup>12</sup>	4.081x10 <sup>11</sup>
Reduced in 100% H <sub>2</sub> at 230°C	0.683	0.520x10 <sup>12</sup>	2.400x10 <sup>11</sup>
Reduced in 100% H <sub>2</sub> at 250°C	0.658	0.531x10 <sup>12</sup>	2.550x10 <sup>11</sup>
Reduced in 100% H <sub>2</sub> at 200°C	0.681	0.954x10 <sup>12</sup>	4.400x10 <sup>11</sup>
Reduced in 100% H <sub>2</sub> at 250°C	0.046	0.401x10 <sup>12</sup>	2.760x10 <sup>11</sup>
Reduced in 3.59% H <sub>2</sub> , 96.41% Ar at 300°C	1.278	1.270x10 <sup>12</sup>	3.140x10 <sup>11</sup>
Reduced in 3.59% H <sub>2</sub> , 96.41% Ar at 250°C	1.295	1.212x10 <sup>12</sup>	2.960x10 <sup>11</sup>
Reduced in 3.59% H <sub>2</sub> , 96.41% Ar at 200°C	1.951	0.727x10 <sup>12</sup>	1.180x10 <sup>11</sup>
Reduced by Hydroquinone <sup>a</sup>	0.094	0.140x10 <sup>12</sup>	4.720x10 <sup>11</sup>

N.B.: Reductions were carried out in a ceramic tube in flowing H<sub>2</sub> as outlined in Figure 5.

a = sample was ground in a mortar and mixed with a few drops of aqueous hydroquinone solution.

TABLE 12

Resistivities of Products on Reduction in Parr Bomb at High H<sub>2</sub> Pressure

	<u>Time</u>	<u>Pressure (atm)</u>	<u>Specific Resistivities (ohm-cm)</u>
1. Pure unreduced sample at 25°C	0	180	3.20x10 <sup>12</sup>
2. Sample reduced at 200°C	1 hr.	113	6.37x10 <sup>12</sup>
3. Sample reduced in air at 25°C	1 hr.	180	2.03x10 <sup>12</sup>
4. Sample reduced at 25°C	10 hrs.	180	3.10x10 <sup>12</sup>
5. Sample reduced at 71°C	2 hrs.	156	2.10x10 <sup>12</sup>

h. Flame Test

A piece of copper polyacrylate ( $\text{Cu}(\text{PA})_2$ ) salt was put in a metal spatula and held over a Bunsen burner flame. Also the polyacrylic acid sample was put through the same procedure as  $\text{Cu}(\text{PA})_2$ . Results are given below:

TABLE 13

Flame Test Observations

<u>Sample</u>	<u>Observation</u>
I. $\text{Cu}(\text{PA})_2$	Turns black, decomposes at high temperatures, with PAH burning.
II. PAH	Melts when heated, burns with flame and becomes molten black.

i. Acid Test

A piece of each sample previously reduced with 100% H<sub>2</sub> in Parr bomb was put into a beaker containing some conc. HCl and the reactions observed. Results are given in Table 14 below:

TABLE 14Reaction of Cu(PA)<sub>2</sub> Samples with Conc. HCl

<u>Sample</u>	<u>Observation</u>
a) Blue Cu(PA) <sub>2</sub> (as prepared; no reduction)	White gelatinous precipitate plus yellow solution. Looks like Cu <sup>+2</sup> was leached out leaving precipitated PAH behind.
b) Cu(PA) <sub>2</sub> reduced in Parr bomb by H <sub>2</sub> at 71°C (Copper-brown)	Yellow solution (Cu <sup>+2</sup> leached out); plus dark brown residue. On standing this residue becomes black, maybe due to copper oxide formation.
c) Cu(PA) <sub>2</sub> reduced in Parr bomb by H <sub>2</sub> at room temperature (black)	Yellow solution (Cu <sup>+2</sup> leached out); plus gelatinous white precipitate (PAH) plus some spots.

After four hours in flask, all looked the same; yellow solution with gelatinous white precipitate.

j. X-Ray Diffraction

X-Ray diffraction powder patterns were obtained by using a Norelco instrument with 57.3 mm radius powder cameras. The x-ray patterns show  $\text{Cu}(\text{PA})_2$  to be non-crystalline. The product of its reduction at room temperature is still amorphous, while at  $71^\circ\text{C}$  it contains crystalline metallic copper.

According to the diffraction patterns tabulated below (see Table 15), the sample reduced at room temperature is amorphous, while the product of reduction at  $71^\circ\text{C}$  contains crystalline copper.

TABLE 15  
X-Ray Diffraction Powder Patterns

Cu (4-0836)		Sample Reduced by $\text{H}_2$ in Parr Bomb ( $71^\circ\text{C}$ )	
$d(\text{\AA})$	$I/I_1$	$d(\text{\AA})$	Intensity
2.088	100	2.10	strong
1.808	46	1.81	medium
1.278	20	1.26	weak
1.090	17	1.095	weak +
1.0436	5	1.050	very weak
0.9038	3		
0.8293	9		
0.8083	8		

$\text{Cu}(\text{PA})_2$  reduced at room temperature does not exhibit an x-ray pattern.

k. Diffuse Reflectance Spectra

Diffuse reflectance spectra were obtained with a Beckman DU Spectrophotometer and also with a Perkin-Elmer 300 Spectrophotometer (the latter in the laboratory of Dr. Helmut Eckhardt, Allied Corporation, Morristown, New Jersey). Diffuse reflectance spectra on related compounds were also measured to provide comparison with the polyacrylates. (See Table 16 below.)

These included spectra of:

1.  $\text{Cu}(\text{PA})_2$  - (As prepared; no reduction)- (blue)
2.  $\text{Cu}(\text{PA})_2$  - reduced in 100%  $\text{H}_2$  in Parr bomb for ten days at  $25^\circ\text{C}$  (black)
3.  $\text{Cu}(\text{PA})_2$  - reduced in 100%  $\text{H}_2$  in Parr bomb at  $71^\circ\text{C}$ .
4.  $\text{Cu}(\text{PA})_2$  - reduced in 100%  $\text{H}_2$  in Parr bomb at  $91^\circ\text{C}$

TABLE 16

Absorption Peaks for Diffuse Reflectance Spectra

<u>Sample</u>	<u>Figure</u>
1. $\text{Cu}(\text{PA})_2$ - (As prepared no reduction) at $25^\circ\text{C}$	5
2. $\text{Cu}(\text{PA})_2$ - reduced in 100% $\text{H}_2$ in Parr bomb for ten days at $25^\circ\text{C}$	6
3. $\text{Cu}(\text{PA})_2$ - reduced in 100% $\text{H}_2$ in Parr bomb at $71^\circ\text{C}$ .	7
4. $\text{Cu}(\text{PA})_2$ - reduced in 100% $\text{H}_2$ in Parr bomb at $91^\circ\text{C}$ .	8



Cu(PA)<sub>2</sub> - As prepared; no reduction  
(blue)

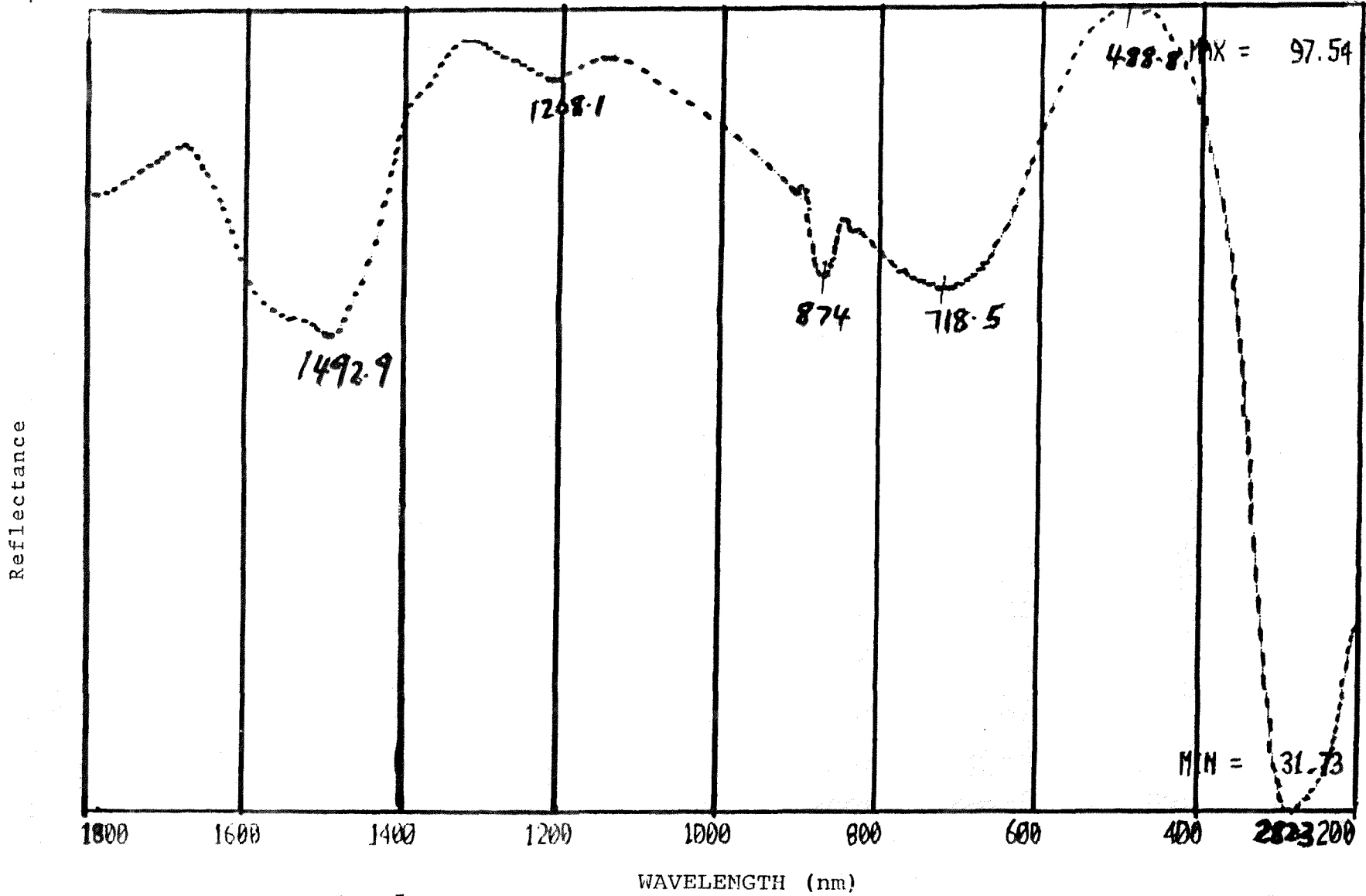

Fig. 5

Cu (PA)<sub>2</sub> - Reduced in 100% H<sub>2</sub>  
in Parr-bomb for ten days  
at 25<sup>o</sup>c (black)

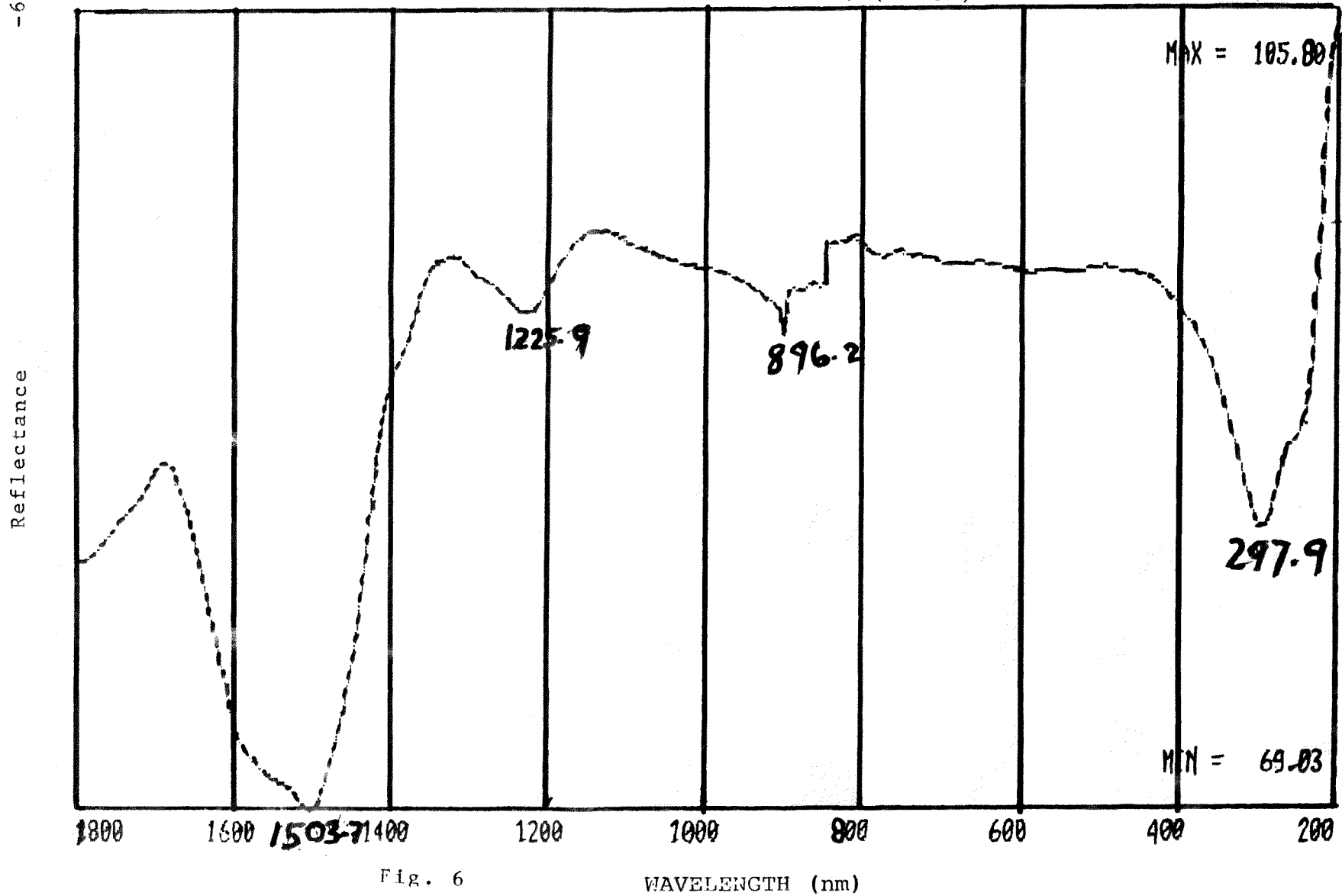

Fig. 6

WAVELENGTH (nm)

Cu (PA)<sub>2</sub> - Reduced in 100% H<sub>2</sub> in  
Parr-bomb at 71°C (copper-brown)

-68-

Reflectance

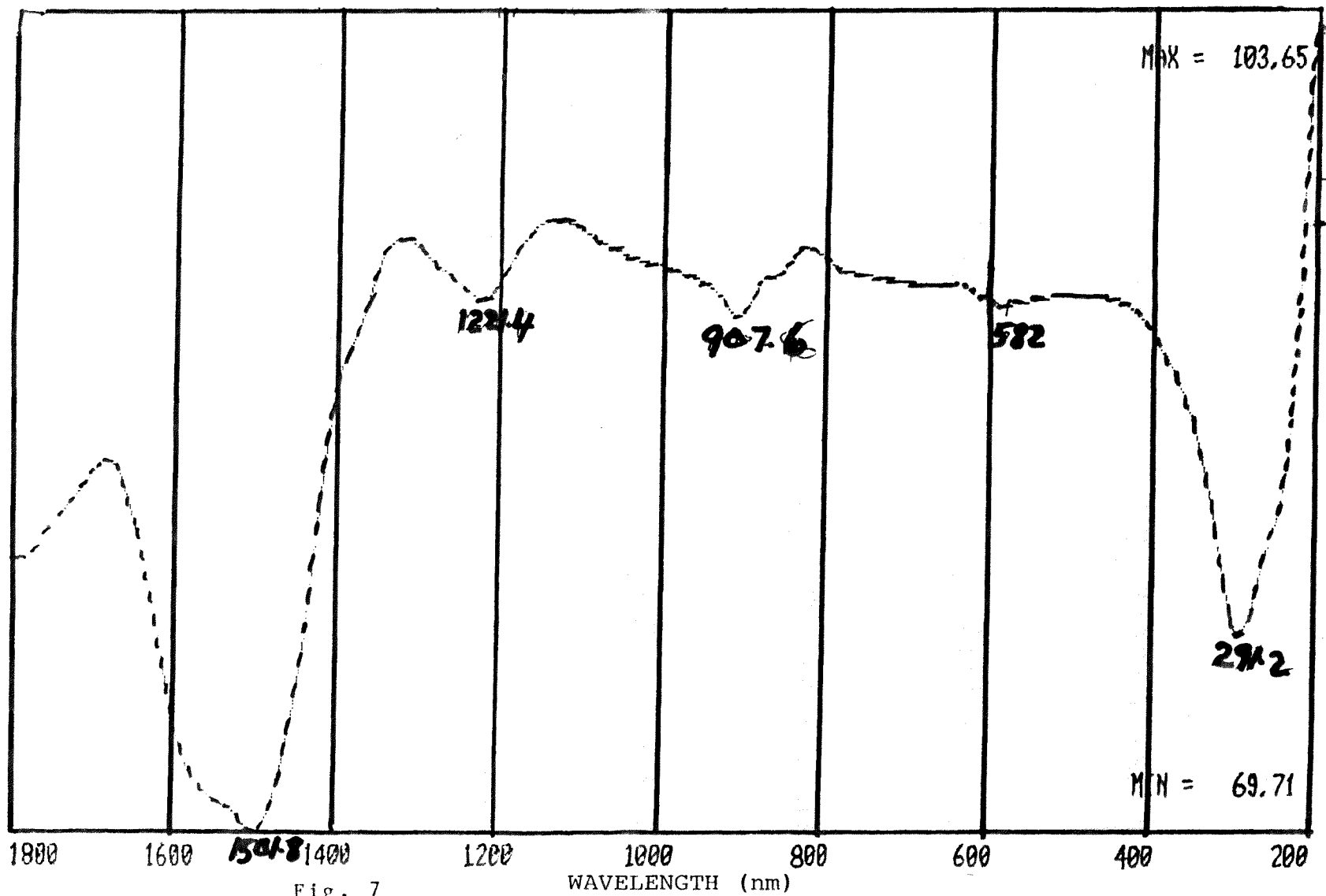

Fig. 7

$\text{Cu}(\text{PA})_2$  - Reduced in 100%  $\text{H}_2$  in Parr-bomb at  $91^\circ\text{C}$  (Copper-brown)

Reflectance

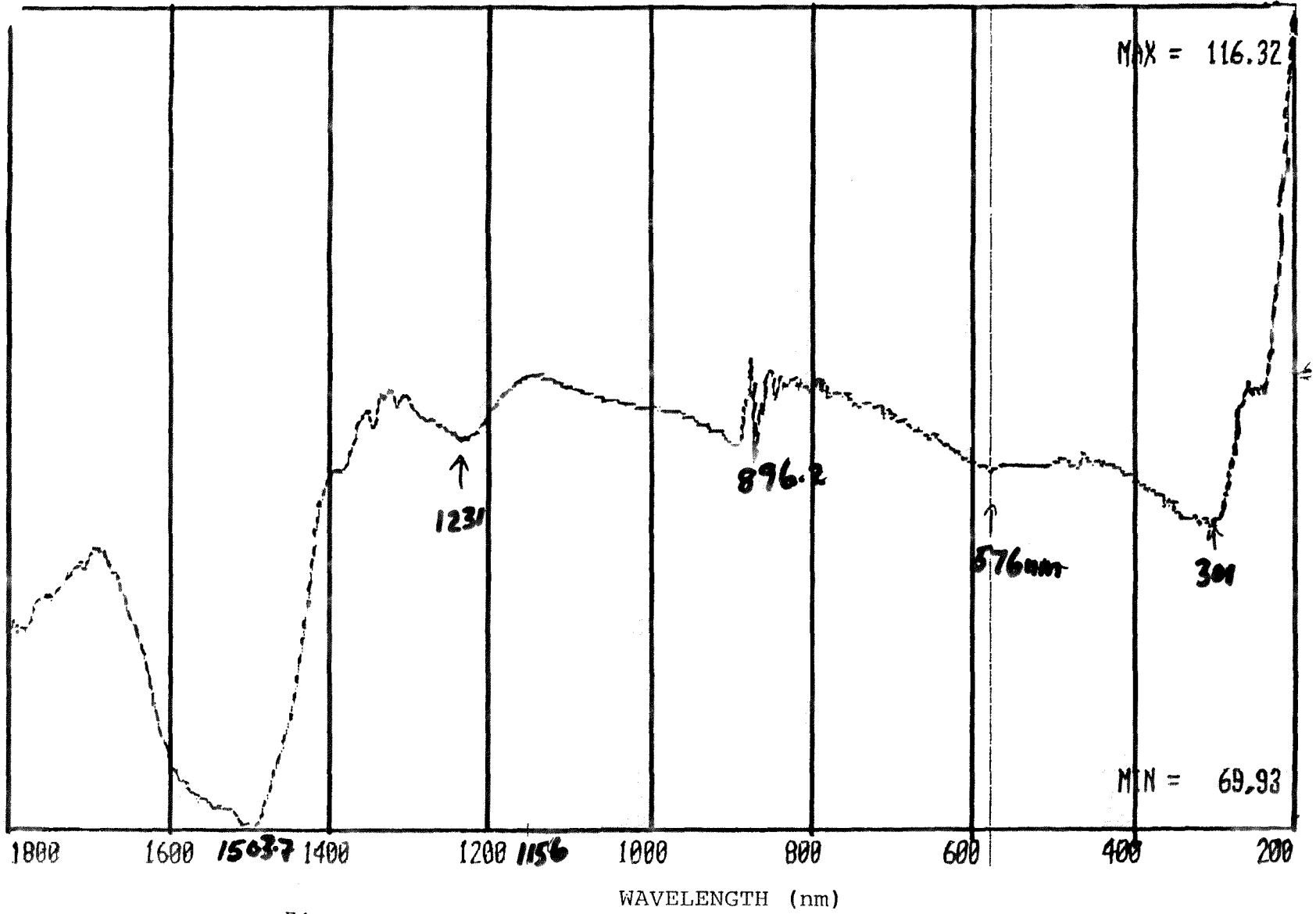

Fig. 8

### iii Ferrous and Ferric Polyacrylates

Ferrous and ferric polyacrylates were also precipitated. The former was found to be blue-green, hard, brittle and electrically insulating and the latter yellowish tan and unfilterable.

Ferrous Polyacrylate: Calculated stoichiometric amounts of PAH and NaOH were mixed together to yield  $\text{Fe}(\text{PA})_2$ . Then a stoichiometric quantity of  $\text{FeCl}_2 \cdot 4 \text{H}_2\text{O}$  (from J.T. Baker) was added to the mixture with argon gas bubbling in. The precipitate was filtered and air-dried; it was bluish green and an insulator.  $\rho = 7.05 \times 10^{12}$  ohm-cm).



Ferrous-Ferric Polyacrylate: In another preparation, ferrous polyacrylate was first precipitated and then while still wet, about 20% of it oxidized to the ferric state by addition of  $\text{I}_2$ .

The same procedure as outlined above for the preparation of ferrous polyacrylate was also used to prepare  $\text{Fe}(\text{PA})_3$ . However, in this case anhydrous  $\text{FeCl}_2$  from Fisher Scientific Company was used. The precipitate was dried at room temperature with a vacuum pump. The dried product is soft and yellowish tan, unfilterable, and also an insulator ( $\rho = 1.3 \times 10^{12}$  ohm-cm).

None of the Fe preparations is crystalline to x-rays.

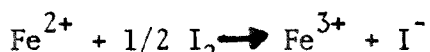

### III. DISCUSSION AND RESULTS

The x-ray diffraction pattern for prospective Cu(I) polyacrylate shows the presence primarily of CuCl. This shows that the Cu(I) polymer did not form. X-ray diffraction also shows that the Cu(II) polyacrylate is amorphous.

The Cu(II) polyacrylate exhibits an intense blue color found to be due to a reflectance peak at 488.8 nm (Fig. 5). The species reduced in Parr bomb at high H<sub>2</sub> pressure and room temperature has flat reflectance through the visible region, which is characteristic of the black color observed (Fig. 6). Fig. 5 shows an absorption peak in the U.V. region at 282.3 nm and a strong reflectance peak in the visible at 488.8 nm. This accounts for the blue color. Figs 7 and 8 show absorption at 281.2 nm and 301 nm respectively in the u.v. region and absorption from 400-600 nm in the visible, and rising reflectance from 600-800 nm. This is probably the quantitative picture of the copper-brown color. However, the PAH did not change in the Parr bomb when in 100% H<sub>2</sub>. Since the PAH did not change, this proves the change is in the copper.

The presence of intense absorption in the visible region is an obvious and striking feature of mixed valence compounds, which is not present in the compounds containing either valence state alone. Also, according to Stieglitz<sup>12</sup>, the color may be intimately connected with the inter-atomic oxidation-reduction tendency of the compound. The distribution of oxidation or reduction states within the molecule can exchange under the influence of light so as to produce the light

absorption and hence color. The wavelengths of these absorption peaks (reflectance troughs) in the U.V. for the Cu(II) polymer increase as the reduction temperature increases, i.e., 282.3 nm vs. 301 nm (see Figs. 5 and 8). Huizenga and others<sup>50,51</sup> proposed that when there is a large ratio of copper to adjacent or non adjacent carboxyl groups, the species exists as an intertangled network of the species present in solution. Intramolecular association through the copper occurs to such an extent that the chain is partially or fully constricted, which contributes more to stiffness due to restrictions on rotation or a smaller tendency for interchange between reaction sites. This constriction is offset by increasing neutralization (see Table 16).

A strong absorption peak has been previously observed at 257 nm for aqueous solutions and gels of polyacrylic acid and copper perchlorate (with excess polyacrylic acid).<sup>53</sup> This demonstrates that each cupric ion replaces two hydrogens, thus suggesting the formation of a chelate. Presumably such a chelate could distort the polymer chain, but it is observed at 282.3 nm for the Cu(II) polyacrylate (Fig. 5), 297.9 nm for those reduced at 25°C for ten days (Fig. 6) and at 301 nm for those reduced at 91°C (Fig. 8). Ours was slightly shifted towards higher wavelengths (282.3, 297.9, 301 nm) because they were in solid states.

From the data presented (Tables 6 and 7), it is possible that the species has some  $\text{Cu}^{2+}$  ions bonded to adjacent carboxyl groups.

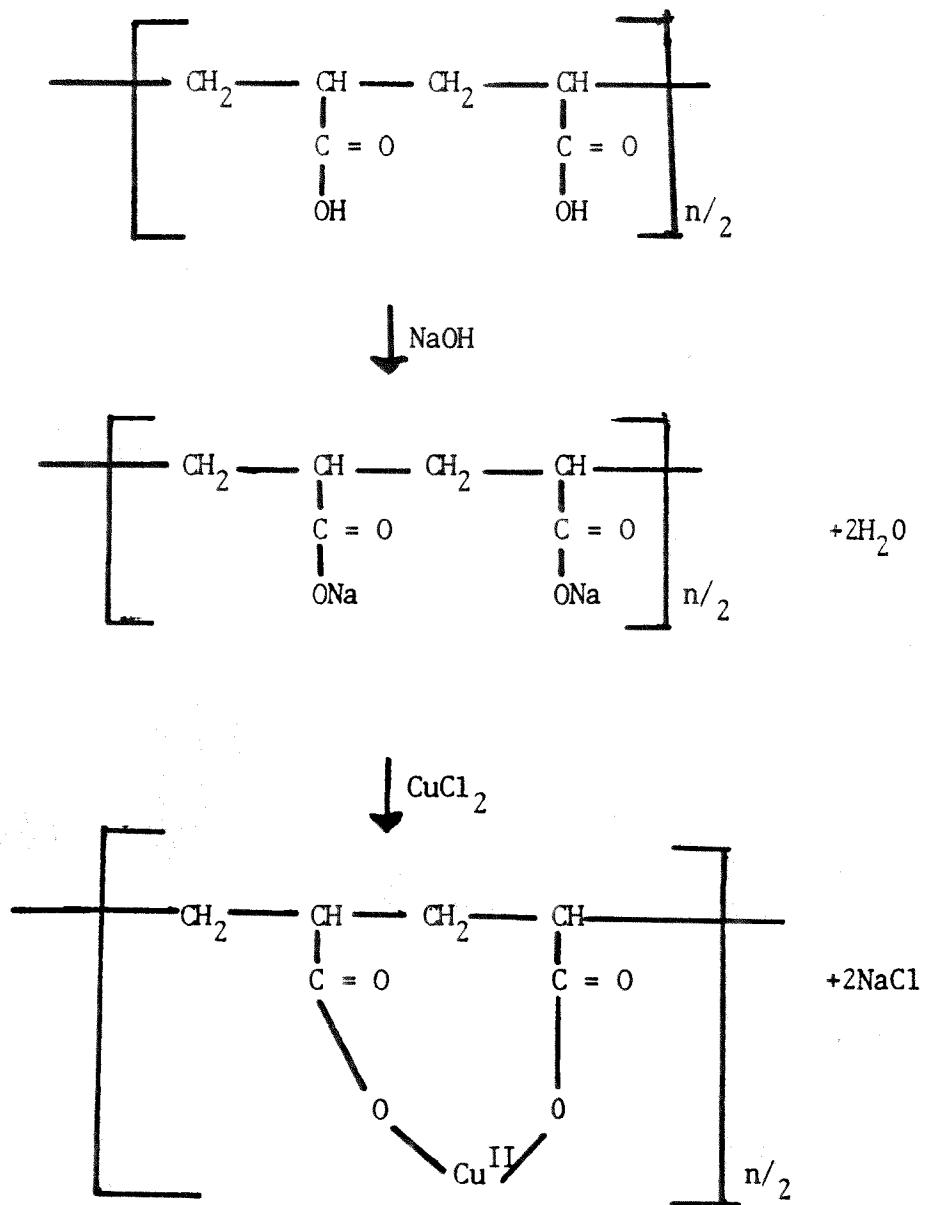

However, it is much likely crosslinked because it precipitates:



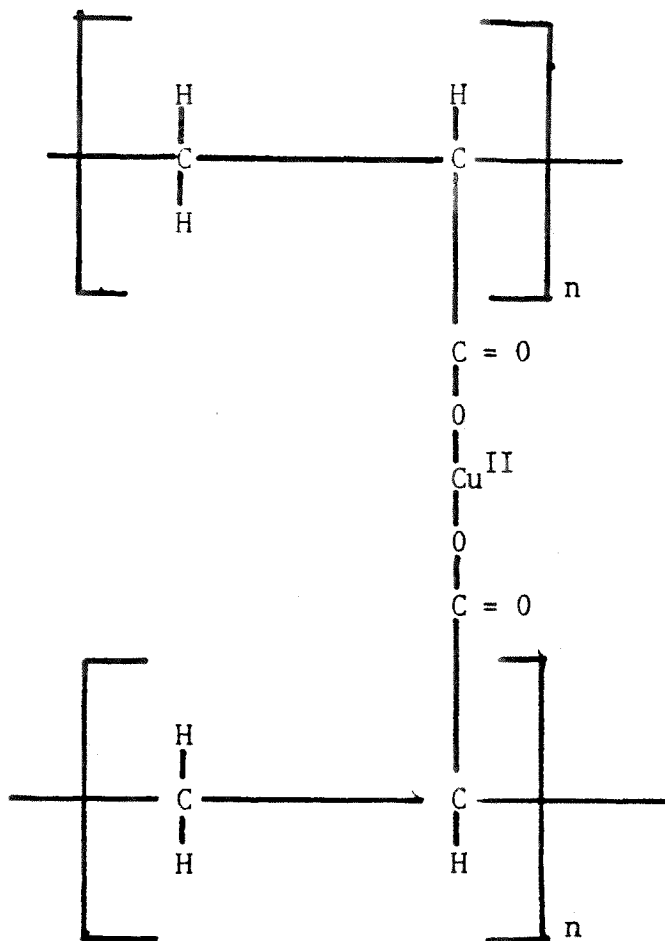

The high resistance,  $10^{12}$  ohm-cm, obtained could perhaps be due to the presence of water left behind when the sample is reduced. However, it may be that it is non-conducting because we do not have both  $\text{Cu}^+$  and  $\text{Cu}^{2+}$  present, or that, if we have, the copper ions are too far apart. It may also be that the blackness obtained on reduction at  $25^\circ\text{C}$  is due to extremely small particles of metallic copper, as opposed to somewhat larger particles when the usual copper-brown color is observed on reduction at  $71^\circ\text{C}$  to  $90^\circ\text{C}$ .

Since there are a large number of interesting compounds related to polymers containing inorganic ions still to be prepared, there are some challenges to be overcome. Perhaps, one of the next major challenges is to develop totally new and different compounds which might improve and or stimulate mechanical and electrical properties and chemical stability (oxidation or reduction). However, another challenge is defects of various kinds - such as crosslinks between chains, chain-ends, and bends and kinks in the polymer chain, which are common in polymers. Also the doped forms are not amenable to processing, and they can be unstable to air-oxidation. Consequently, much work remains before the basic conduction process in "polymers containing inorganic ions" is understood. However, this is a unique frontier well worth exploring further.

#### IV CONCLUSION

The analytical data show that each cupric ion replaces two hydrogens. This and the insolubility of the product suggest the formation of crosslinks. The only product formed is  $\text{Cu}(\text{PA})_2$  (where PA represents an acrylate mer in polyacrylate) as shown in Table 6. However, if we have  $\text{Cl}^-$  in the product, there could be one copper for each mer; because all  $\text{Cl}^-$  remains in solution (that is in filtrates) as given in Table 8, we do not have



The absorption spectra in the visible (400 nm -700nm) offer a quantitative picture of the color observed visually (figs. 5-8). A strong absorption peak has been previously observed at 257 nm for aqueous mixtures of polyacrylic acid and copper perchlorate<sup>53</sup>, while the absorption peaks in the samples are higher, 282.3 nm for  $\text{Cu}(\text{PA})_2$ , 297.9 nm for those reduced at 25°C in 100%  $\text{H}_2$  gas and 301 nm for those

reduced at 91°C in 100% H<sub>2</sub> gas. This shift to higher wavelength in the ultra-violet region is probably because our sample is solid. The reflectance peak for species reduced at 25°C (amorphous black color) which may be due to particle size of metallic copper, shows lower reflection, that is, it is flat through the visible, a characteristic of black color; while at 71°C and 91°C the reflectance rises with increasing wavelength starting at about 576 nm. This is the quantitative expression of the copper brown color which is due to metallic copper. In the near infrared region, all samples (Figs. 5-8) have almost identical absorption properties. This near infrared spectra confirms that all these are chemically the same in the form and bonding in the solid state (Table 16) but they differ in their color (Figs. 5-8) as confirmed in the visible region of the spectrum.

The solid crosslinked polymer is an insulator (see Table 12). Because the materials reduced at low temperatures should still be quite porous and contain extremely finely divided Cu or a mixture of oxidation states, it is quite possible that they would make excellent catalysts.

Also, the ferrous polyacrylate is hard and brittle like cupric polyacrylate, while the partially I<sub>2</sub>-oxidized ferrous polyacrylate is soft (and yellowish tan).

Finally, most of the results from the Tables and Figures suggests that a copper polyacrylate exists, presumably a crosslinked or chelate structure involving carboxyl-groups, and, also the formation for the synthesis is 1 mole copper (II) to 2 moles polyacrylic acid, that is  $\text{Cu}(\text{PA})_2$ .

## V. REFERENCES

1. Wall, F.T. and Drenan, J.W., J. Poly Sci. 7, 83, 1951
2. Robin, M.B., and Peter Day, Advances in Inorganic Chemistry and Radiochemistry, Vol. 10, 247 (1967)
3. Powell, H.M., Proc. Chem. Soc., p. 73 (1959)
4. Berzelius, J.J., "Lehrbuch," 5th ed., Vol. 4, p. 22 (1847).
5. Werner, A.Z., Anorg Allegem, Chem. 12, 46 (1896).
6. Hofmann, K.A., and Resenscheck, F., Ann. Chem., 342, 364 (1905).
7. McCarthy, G.R., Am. J. Sci. 12, 16 (1926)
8. Hofmann, K.A., and Hoschele, K., Ber. Deut. Chem. Ges. 48, 20 (1915).
9. Wells, H.L., Am. J. Sci. 3, 417 (1922).
10. Streintz, F., in "Sammlung Elektrotechnischer Vortrage," Vol. 4, Stuttgart, Enke, (1903).
11. Biltz, W., Z. Anorg. Allgem. Chem. 127, 169 (1923).
12. Stieglitz, J., Proc. Natl. Acad. Sci. U.S. 9, 308 (1923).
13. Cowan, D.O., and Wiygul, F.M., (John Hopkins University) Chemical and Engineering News, pp. 28-45, July 21, 1986.
14. Holliday, L., Ed. "Ionic Polymers," Applied Science Publishers, London, (1975).
15. Eisenberg, A., and King, M., "Ion Containing Polymers", Acad. Press, New York (1977).
16. Eisenberg, A., Polymer Preprints 20, p. 286 (1979).
17. Bazuin, C.G., and Eisenberg, A. Journal of Chemical Education, 58 (11), 938, (1981).
18. Carraher, Charles E., Jr., Journal of Chemical Education, 58 (11), 923 (1981).
19. Pittman, C. and Marlin, G., Journal Polymer Science, Polymer Chemistry Edition 11, 2753 (1973).

20. Subramemian, R.V., "Advances in Organometallic Polymers," (Editors Carraher, C.E., Jr., Sheats, J.E., Pittman, C.U., Jr.), Marcel Dekker, N.Y. (1981).
21. Pittman, C., and Sasaki, Y., Chem. Lett. 4 383 (1975).
22. Brown, G.M., Meyer, T.J., Cowan, D., Levanda, C., Kaufman, F., Roling, P.V., and Rausch, M.D., Inorganic Chem. 14, (3), 506 (1975).
23. Neuse, E. and Rosenberg H., "Metallocene Polymers," Marcel Dekker, N.Y. (1970).
24. Gal A., Cais M., Kohn D.H., Journal of Polymer Science, Part A-1, 9, 1853 (1971).
25. Mott, N.F., Nuovo Cimenti, 7 (10), Suppl., 312 (1958).
26. Zener, C. and Heikes, R.R., Rev. Mod. Phys. 25, 191 (1953).
27. Zener, C., Phys. Rev. 81, 440 (1951).
28. (a) Ludwig Braun Jr., Joseph B. Aidala, Coleman B. Brosilow, Section 25, p. 32 in Chemical Eng. Handbook, 4th edition edited by Robert H. Perry, Cecil H. Chilton, Sidney D. Kirkpatrick, McGraw Hill Book Co., Inc., N.Y. 1963.  
(b) Dekker, A.J., "Elec. Eng. Materials" pp. 151-198, Prentice Hall, Englewood Cliffs, N.J. (1959).  
(c) Truxal, J.G., "Control Engineers Handbook" Section 8.1-8.4, McGraw-Hill, N.Y. (1958).  
(d) Sproull, R.L., "Modern Physics" pp. 247-250, N.Y. (1956).
29. Souchay, P., Bull. Sci. Chem. France 7, 875 (1940).
30. Harris, G.M., J. Proc. Roy. Soc. N.S. Wales 84, 111 (1950).
31. Harris, G.M., J. Proc. Roy. Soc. N.S. Wales 85, 138 (1950).
32. Harris, G.M., J. Proc. Roy. Soc. N.S. Wales 85, 142 (1950).
33. Harris, G.M., J. Proc. Roy. Soc. N.S. Wales 85, 142 (1952).
34. Harris, G.M. and Schaeffer, H.N.S., J. Proc. Roy. Soc. N.S. Wales 85, 145 (1952).
35. Harris, G.M., J. Proc. Roy. Soc. N.S. Wales 85, 148 (1952).

36. Brauer, G. and Eichner, M., Z. Anorg. Allgem. Chem., 285, 118 (1956).
37. Morgan, G.T., and Burstall, F.H., J. Chem. Soc. Part II 27, 2018 (1926).
38. Treadwell, F.P., and Von Girssewald, C., Z. Anorg. Allgem. Chem. 28, 84 (1904).
39. Mikhalevich, K.N. and Litvinchuk, V.M., Zh. Neorg. Khim. 9, 2391 (1964).
40. Cooper, D., and Plane, R.A., Inorg. Chem. 5, 1677 (1966).
41. Mori, M., Bull. Chem. Soc. Japan, 33, 985 (1960).
42. Mori, M., Bull. Chem. Soc. Japan, 34, 1249 (1961).
43. Culpin, D., Day P., Edwards P.R., Williams R.J.P., Chem. Commun. 19, 450, (1965).
44. Perreti, E.A. The Encyclopedia of the Chemical Elements, pp. 163-173. Edited by Hampel, C.A., Reinhold Book Corp., USA, 1968.
45. Sidgwick, Chemical Elements and their Compounds. Oxford University Press, 1950.
46. Wells, A.F., J., Chem. Soc. 1670 (1947); Harker, D., Z., Krist, 93, 136 (1936); Boye, E., Z. Anorg. Chem. 215, 75 (1933).
47. Pamphlet No. GC-67 from B.F. Goodrich Chemical Division. "Carbopol Water Soluble Resins".
48. Crescenzi, V., Chirico, D.A.; Ripamonti, A., Ricerca Sci. 28, 369, (1958); 29, 1424, (1959); Chem. Abstr. 54, 4109 (1959); Resins, Rubbers, Plastics (III), 1 (14), 1663, (1962).
49. Hopkins, R.P., Ind. Eng. Chem. 47, 2258 (1955).
50. Huizenga, J.R., Grieger, P.F., and Wall, F.T., J. Am. Chem. Soc. 72, 2636 (1950).
51. Huizenga, J.R., Grieger, P.F., and Wall, F.T., J. Am. Chem. Soc. 72, 4228 (1950).
52. F.T. Wall, J.J. Ondrejcin and M. Pikramenou, Ibid, 73, 2821 (1951).



53. F.T. Wall and S.J. Gill, J. Phys. Chem. 7, 58 (1954).
54. W. Kern, Z. Physik Chem., A181, 249 (1938); Biochem. Z.,  
301, 338 (1939).
55. A. Katchalsky and P. Spitnik, J. Polymer Sci. 2, 432 (1947).
56. R. Arnold and J.T.G. Overbeck, Rec. Trav. Chim., 69, 192 (1950).
57. A. Oth and P.M. Doty, J. Phys. Chem 56, 43 (1952).
58. Gregor, H.P. and Frederick, M., Journal of Polymer Sci. 23,  
451, (1957).
59. Gregor, H.P., Luttinger L.B., and Loebel, E.M., J. Phys.  
Chem. 59, 34 (1955).

## VI. BIBLIOGRAPHY

Melvin B. Robin and Peter Day, "Advances in Inorganic Chemistry and Radiochemistry," Vol. 10, pg. 247 Editors H.J. Emeleus and A.G. Sharpe, Academic Press, New York, 1967.

Analytical Separation and Determinations. Edited by C.T. Kenner, The MacMillan Company, New York, 1971.

Ionic Polymers, Edited by Leslie Holliday, Applied Science Publishers, London, 1975.

Developments in Ionic Polymers - 1, Edited by A.D. Wilson and H.J. Prosser, Applied Science Publishers, New York, 1983.

Cowan, D.O., and Wiygul, F., Chemical and Engineering News, Vol. 64, No. 29, pp. 28-45, July 21, 1986.

Kurt Nassau, The Physics and Chemistry of Color. The Fifteen Causes of Color, published by John Wiley & Sons, Inc. 1983.