

Copyright Warning & Restrictions

The copyright law of the United States (Title 17, United States Code) governs the making of photocopies or other reproductions of copyrighted material.

Under certain conditions specified in the law, libraries and archives are authorized to furnish a photocopy or other reproduction. One of these specified conditions is that the photocopy or reproduction is not to be “used for any purpose other than private study, scholarship, or research.” If a user makes a request for, or later uses, a photocopy or reproduction for purposes in excess of “fair use” that user may be liable for copyright infringement,

This institution reserves the right to refuse to accept a copying order if, in its judgment, fulfillment of the order would involve violation of copyright law.

Please Note: The author retains the copyright while the New Jersey Institute of Technology reserves the right to distribute this thesis or dissertation

Printing note: If you do not wish to print this page, then select “Pages from: first page # to: last page #” on the print dialog screen

The Van Houten library has removed some of the personal information and all signatures from the approval page and biographical sketches of theses and dissertations in order to protect the identity of NJIT graduates and faculty.

OFFICE TECHNOLOGY : A DETERMINANT
IN THE ORGANIZATION OF SPACES

by

Se Hun Kim

Thesis submitted to the Faculty of the Graduate School of
the New Jersey Institute of Technology in partial
fulfillment of the requirements for the degree of
Master of Science in Architectural Studies
1990

VITA

Name: Se hun Kim.

Degree and date to be conferred: Master of Science in
Architectural Studies, 1990.

Secondary education:

High school attended: Dae shin High School, Seoul, Korea.
Mar 1974 to Feb 1977.

Collegiate institutions attended	Dates	Degree	Date of degree
Kon Kuk University	3/77 to 2/81	BS	Feb 1981.
Kon Kuk University	3/81 to 2/83	MS	Feb 1983.
New Jersey Institute of Technology	9/87 to 10/90	MSAS	Oct 1990.

Major: Architecture.

Publications: A study for children-playing-space in urban
apartment complex. Graduate thesis 1983.

Title of thesis : Office technology: A determinant in the organization of spaces

Se hun Kim, Master of Science in Architectural Studies, 1990

Thesis directed by : David L.Hawk
Professor, School of Architecture

ABSTRACT

Technological advances have initiated complexity in buildings and may also provide the means to manage it. Research in advanced technology development suggests new directions for development and application of advanced technologies to buildings.

The purpose of this research is to examine and develop an understanding of building related computer uses. This study is done by literature search and field survey. Through literature search the theoretical background is established. Through field survey practical guidelines are suggested.

Studies of social and physical organizational systems and building systems are surveyed, then computers and advanced technologies are introduced. This is to find out practical applications and examples. The research then focuses on a detailed example of relationship between buildings and advanced technologies. This is based on interview and questionnaire information from four different companies.

The work concludes with guidelines on how buildings and advanced technologies can and should relate to each other.

TABLE OF CONTENTS

chapter	page
I. INTRODUCTION - - - - -	1
II. GENERAL MANAGEMENT ORGANIZATIONAL SYSTEMS - - - - -	4
A. Hierarchy	
B. Matrix	
C. Network	
III. BUILDING SYSTEMS - - - - -	12
A. Space Systems	
B. Structural Systems	
C. Mechanical Systems	
D. Circulation Systems	
E. Opening Systems	
F. Electronic and Communication Systems	
IV. COMPUTERS AND TECHNOLOGIES - - - - -	20
A. Computers	
B. Office Technologies Systems	
C. Activities	

V. CASE STUDIES - - - - -	30
A. Survey	
B. Analysis of Behavior Related to Productivity	
C. Analysis of Technologies	
D. Quality of Space	
VI. GUIDELINES FOR ARCHITECTURAL DESIGN - - - - -	51
A. Work Space and Privacy	
B. Task and Equipment Support to the Task	
C. Communications and Meetings	
D. Flexibility of Space	
E. A Virtual Office	
F. Other Considerations	
G. Summary of Properties	
APPENDIX 1 - - - - -	65
APPENDIX 2 - - - - -	71
BIBLIOGRAPHY - - - - -	72

LIST OF TABLES

table	page
2 - 1. Organization system - - - - -	10
4 - 1. Technologies according to systems - - - - -	27
5 - 1. Equipment distribution - - - - -	46
6 - 1. Existing equipment distribution - - - - -	55
6 - 2. Minimum desirable equipment - - - - -	56

6 - 3. Space relationship - - - - - 58
6 - 4. A change of visual contact - - - - - 59

CHAPTER I

INTRODUCTION

Society is growing in size and complexity. As a response, buildings are designed with greater complexity. Technological advances, many associated with computers, have initiated different aspects of this process and may also provide the means to manage it. This thesis outlines what has been done and what possibilities remain to be pursued. Research in advanced technological development suggests new directions for application of advanced technologies to buildings both as a metaphor and as a model of building design and operation.

Currently, for efficient work in large offices, to improve productivity, especially as they link to human

activities associated with buildings, we should take into account socio-economic issues of labor, finance, technology, and management, and physical issues associated with materials. This study mainly aims to focus on the advanced technologies used in general office environment.

The scope of advanced technologies is wide. It contains microprocessors, fiber optics, alternative materials, etc. This study will focus on the microprocessor and its related usages in advanced building technologies.

Many companies have already made significant use of advanced technologies related to automation and telecommunication to design, construct, operate and maintain buildings and improve general business activities. The research illustrates how computers relate to the operation of buildings and where computers can be useful to further increases in efficiency.

It is important to develop an understanding of the structure of building-related computer uses. This is done in the study by reference research and a field survey. Through reference research, the theoretical background will be established. Through field survey, practical guidelines will be suggested based on theoretical basis.

The first stage is a study of general organizational systems and building systems. The second is a study of computers and computer-controlled technologies. To

illustrate practical applications and examples, the research presents a detailed example of the relationship between buildings and advanced technologies. To do this, interview and questionnaire techniques are used to collect data from four different companies which are expected to use advanced technologies. (details of survey method will be presented in chapter IV)

Finally, some guidelines on how buildings and advanced technologies should relate to each other are presented.

CHAPTER II

GENERAL ORGANIZATIONAL SYSTEMS

In office buildings, different management theories such as hierarchical, matrix, and network systems are popular. These management theories also require modifications to space planning, therefore new theories demand new layouts. Managers and office technology task forces are beginning to accept responsibility for new technologies and their impact on organizations and their social environment.

Advanced technology products and services have an effect that changes most work processes and organizations radically. The physical environment of the workplace is now perceived as a catalyst of organizational change, the

environment of advanced technology is part and parcel of the business plan of any organization.

In this chapter, these three management systems will be briefly introduced to set a standard of various advanced technologies which will be further discussed in chapter V.

A. Hierarchical Organization

Hierarchy is the rank ordering of elements relative to the range of an attribute, such that importance or value is ascribed according to the presence or absence of the attribute. With ranges the rank ordering can occur in the realm of the formal, spatial, etc.

A hierarchy can be like a set of chinese boxes where one box encloses a second, which encloses a third. While the ordinary set of chinese boxes is a sequence, or complete ordering of the component boxes, a hierarchy is a partial ordering. (Howard, 1973, pp 5)

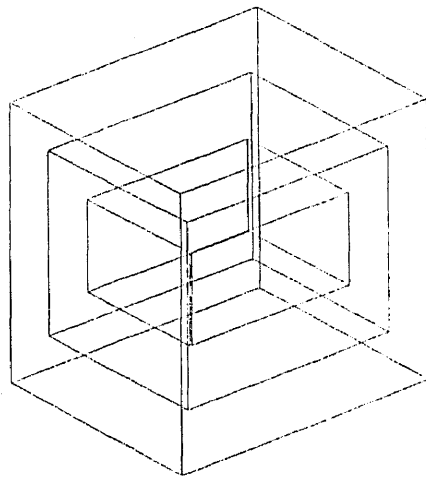

Figure 2 - 1 , Set of Chinese boxes

The logical hierarchy of data units in auxiliary storage is a good example of hierarchical systems.

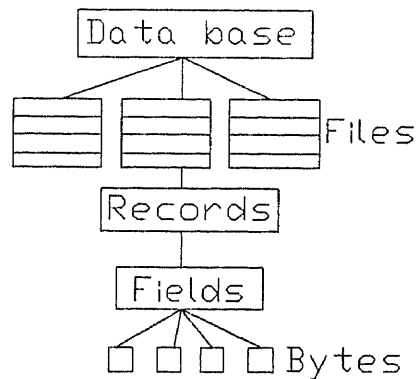

Figure 2 - 2 , The hierarchy of data units

Corporate and bureaucratic worlds are hierarchical and class conscious. As a result employees can be divided into those who are served and those who serve.

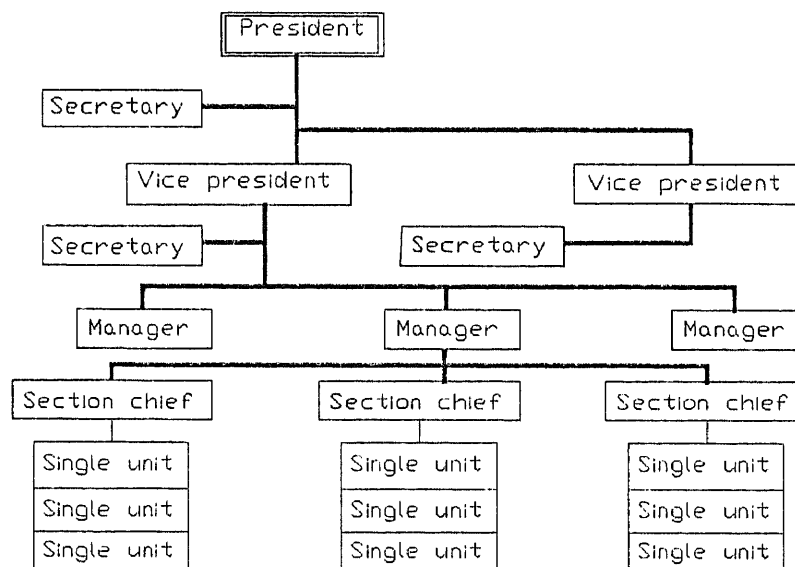

Figure 2 - 3 , A bureaucratic management system

As a formative idea, a hierarchy in the design of buildings is the physical manifestation of the rank ordering of an attribute or attributes. Comparing data structure with buildings, every space or room can also have a hierarchical organization. The president's room often has a more important meaning or position than other managerial rooms.

B. Matrix Organization

A matrix organization is any organization which is integrated by means of a co-ordination function. This is a structural device that coordinates work across unit boundaries, or that allows peers to work together on a collegial basis. The alternative is to super-impose a set of horizontal project groups over the vertical functions. Fig 2 - 4 , by a grid or matrix is the matrix organization.

	A	B	C	D	E	Functions
Projects, 1						
Products or Business Areas	2					
	3					
	4					

Figure 2 - 4 , Matrix organization

In the following figure, it is obvious that elements affect each other. To choose one element, at least two or three pieces of information are required.

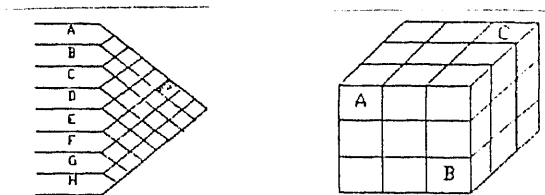

Figure 2 - 5 , Matrix composition of elements

A rectangular array of elements arranged in horizontal rows and vertical columns such as $A = \begin{pmatrix} A_{11} & A_{12} \\ A_{21} & A_{22} \end{pmatrix}$

$$B = \begin{pmatrix} B_{11} & B_{12} \\ B_{21} & B_{22} \end{pmatrix} \quad AB = \begin{pmatrix} A_{11}B_{11} + A_{12}B_{21} & A_{11}B_{12} + A_{12}B_{22} \\ A_{21}B_{11} + A_{22}B_{21} & A_{21}B_{12} + A_{22}B_{22} \end{pmatrix}$$

are all examples of a matrix. As stated in the formula above, particles are related among themselves. The overall result originates from the co-relation of all elements.

In a general office plan system, each space is related to a specific department and services within an organization in accordance with its size and location.

In this system, when compared with hierarchical systems, the horizontal component of the matrix seems to be freed from the shackles of hierarchy and bureaucracy. But to increase efficiency, more information about operation and

effectiveness of matrix management is required.

C. Network system

Basically, a network is composed of nodes and links.

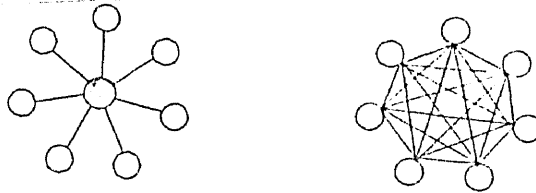

A network is a collection of two or more processing elements that offer varying services and capabilities.

In an office, every room or equipment are connected by network system directly. To control the transmission of information between the basic hardware elements in every unit, there are some type of transmission, control mechanisms, some type of network interface, and a set of agreements or protocol. The entire network can be viewed as one large computing system.

An office automation system should include not only intelligent work stations but also a variety of other devices, such as minicomputer with text and data files, fax machines, intelligent copiers, and so forth. For this system to work and be effective, a more supportable and flexible network system is needed.

We can get following table to summarize the preceding organization systems.

Systems	Variables	Character
<p>Hierarchy</p> 	1	<p>All of the decisions depend on a single head (A). This is a simple organization because of a "simple" variable.</p>
<p>Matrix</p> 	2 or 3	<p>2 or 3 elements (variables) are selected to reach a decision. Simple-minded system.</p>
<p>Network</p> 	n	<p>Elements affect one another. No one to one relationship. Chaotic system.</p>

Table 2 - 1. Organization system.

This chapter reviewed general organizational systems to set a standard of various advanced technologies. Architectural design should be suggested to make the most of each characteristic according to the office management system.

Next chapter will focus on building systems to set a theoretical basis for analyzing the survey.

CHAPTER III

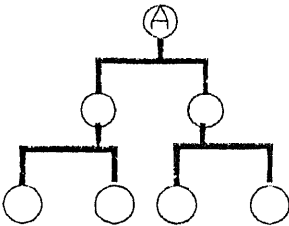
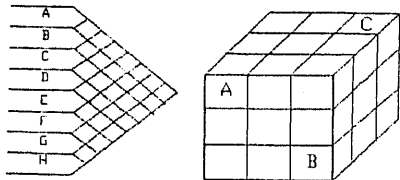
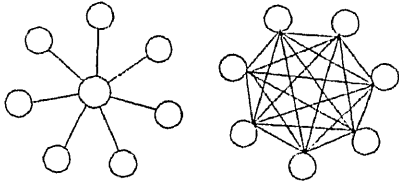
BUILDING SYSTEMS

At the simplest level, in a modern society, a building is a constructed edifice that encloses space. It usually consists of floors, walls, a roof structure, doors, and windows. Its primary purpose is to shelter people and provide a place for their activities. Within buildings people can gain security from the outside.

Shelter had traditionally been passive, but today it is becoming an active membrane between humans and their external environments.

Due to advanced technologies, buildings can provide occupants with advanced environmental control systems, easier communication and other amenities that support

traditional activities or allow the possibility of new activities. This can be easily found in office buildings where work space must meet complex technical and social needs and their rapidly changing performance requirements.

Following is a brief analysis of each building system.

A. Space Systems

Buildings consist of spaces. They are normally composed of a number of spaces that are related to one another by function, proximity, or a circulation path.

The manner in which spaces are arranged can clarify their relative importance and functional or symbolic role in building's organization.

Space organization and their formal characteristics are introduced briefly as follows.

1. Centralized organization : It is a stable, concentrated composition that consists of a number of secondary spaces grouped around a large, dominant, central space. It can be used to establish points or places and terminate axial compositions and serve as an object-form within a defined field or volume of space.

2. Linear : It consists essentially of a series of

spaces. These spaces can either be directly related to one another, or be linked through a separate and distinct linear space. A linear organization which has an exterior exposure can be alike or differ in size, form, and function.

3. Radial : A radial organization of spaces combines elements of both centralized and linear organizations. It consists of a dominant central space from which a number of linear organizations extend in a radial manner.

4. Clustered : It uses proximity to relate its spaces to one another. It consists of repetitive, cellular spaces that have similar functions, and share a common visual trait such as shape or orientation. The form of a clustered organization is flexible, and can accept growth and change without affecting its character.

5. Grid : It consists of forms and spaces whose positions in space and relationships with one another are regulated by a three dimensional grid pattern or field.

(Ching, 1979, pp 206,239)

B. Structural Systems

Structure encloses and defines a space in order to make it useful for a particular function. Structures are capable of holding themselves without appreciable geometric

change during loading and unloading.

In the construction of buildings, structural elements are called upon to span over spaces, and transmit their loads through vertical supports to a building's foundation system. The size and proportion of these elements are directly related to the structural tasks they perform.

A structure depends on the weight and stiffness of a material and more on its geometry for stability.

C. Mechanical Systems

1. H.V.A.C. systems

The term "heating, ventilating and air conditioning" (HVAC) covers a wide range of equipment, from a simple equipment to large and sophisticated, complex equipment required for buildings.

The purpose of this systems are to control temperature and humidity of an air and to keep it clean and clear.

One way to classify HVAC systems is by the media used to transfer heat. The three most common in building applications are air, water, and refrigerant. There are four main system classifications:

- * air - air system
- * air - water system
- * all - water system
- * direct refrigerant system

2. Plumbing systems

This system works by sustaining right amount of water and pressures according to systems. Quality and quantity of water should meet needs of users of buildings. Supply and drain systems are divided by facets which require use of water.

3. Electrical systems

It supplies not only electric outlets and electric lighting, but also the power for ventilation, heating, and cooling equipment; traction power for elevators and material transport; and power for signal and communications equipment.

The major components of a building's electrical power system can be arranged in three major categories; wiring, power handling equipment, and control and utilization equipment. In the first category, it includes conductors and raceways of all types; in the second, transformers, switchboards, panel board, large switches, and circuit

breakers; and in the last, actual utilization equipment such as lighting, motors, controls, and wiring devices.

D. Circulation

The circulation links the spaces of a building, or any series of interior or exterior spaces together. It is defined within a space that is for movement only, or implied within a use space. It has dynamic and static components in all buildings.

Circulation spaces form an integral part of any building organization, and occupy a big amount of space within a building. It accomodates the movement of people as they promenade, pause, rest, or take in a view along its path.

E. Opening Systems

Entering a building, a room within a building, or a defined field of exterior space, involves the act of penerating a vertical plane that distinguishes one space from another, and separates "here" from "there".

Doors and windows serve as connections with the exterior. They also violate the integrity of the wall. Now these elements are increasingly being equipped with security systems.

1. Doors : They are movable pieces of firm material or structure. These swing on pivots or hinges, slide along a groove, roll up and down, revolve, or fold. These are means of passages between spaces, and in and out of a building. This gives the room its direction and its appropriate meaning. It plays a decisive role in this context because they prepare the visitor for the spatial event to come (Krier, 1988, pp 38).

2. Windows : They give us the awareness of the outside world. This is an opening in the wall of a building to admit light or wind and usually to permit vision through a transparent or translucent material, usually glass. Determining the appropriate quantity of light is important. Many devices such as shutters, blinds, lintels and curtains are used on a window.

F. Electronic and Communication Systems

Modern buildings depend on communication systems for normal functioning. There are surveillance equipment such as fire and interior alarm; audio and visual communication equipment such as telephone, intercom, and television; and timing equipment such as clocks and programs.

Some are now incorporated into building mechanical

equipment control systems. The hundreds of signals generated through a large facility are logged, channeled, and controlled by means of specially programmed computers and microprocessors.

All the communication systems that once were separate and distinct are now frequently combined and serve multiple purpose. It brings great and rapid changes than any other area of equipment design and application to buildings.

This chapter reviewed building systems to set a theoretical basis for analyzing the survey. In the next chapter, basic information and relationships between computers, technologies, and activities will be discussed to understand practical survey analysis.

CHAPTER IV

COMPUTERS AND TECHNOLOGIES

The concept of a computer can be used both as a metaphor and as a model of a building design and operation. It is important to analyze advanced technologies (e.g., computers, microprocessors) as a means to improve shelter and to support human activities.

Computers have increased the level of creativity and capability of human economic activities. They are not only used to increase employee productivity through automation, but also as a tool to strengthen customer relationships through data communication links. Computers are revolutionizing many business tasks.

Productivity is increased when people introduce

automation into their work to raise quality in the long run, especially in dangerous or repeated tasks. Advanced technologies are now increasing productivity and making office work more efficient.

The development of technology is being led by automation systems. The number of blue collar jobs are reduced by process control and automation while white collar jobs are changed by data processing, telecommunication, and automation. Efficiency is increased by replacing or supplementing human labor with these advanced technologies.

Microprocessing technology in computers can also help to increase the efficiency of building design, construction, operation and maintenance.

With this in mind, the following analysis of the basic aspects of computer systems, office technology systems and activities are presented.

A. Computers

Computers are devices capable of following programs to operate on data in order to produce desired results. The fundamental aspects of a computer system are divided into hardware and software. Hardware is the computing machinery and associated devices while software is the various programs utilized by a computer system.

1. Computer hardware

Computers are classified into three groups, according to their size and computing power. The largest are called mainframe computers. The mid-range size are minicomputer, and the smallest are microcomputers. Recently, the distinctions between categories are becoming harder to detect, as more computer power is available in increasingly smaller boxes (Natalie, 1984, pp 6).

a. Input device

Through input devices data is fed into a computer in a manner intelligible to it. The various types of input devices used are as follows.

- *. punched card reader
- *. punched paper tape
- *. magnetic tape drive
- *. magnetic disk drive
- *. keyboard
- *. graphic input devices

b. Memory

The size of a computer's memory indicates the power of computer. It determines the size of the programs that can be executed on a computer and the amount of data that can be stored.

c. Control unit

This portion of computer directs and monitors the activities of a computer. It reads the instructions given

to the computer by the software codes and sends the necessary data stored in the memory to the processor (Natalie, 1984, pp 16).

d. Processor

This is the brain of the computer, where the majority of the processing occurs.

e. Output device

The results (or the processed information) may be printed directly on a printer or shown on a screen or a monitor, alternatively: the output can be recorded on magnetic tapes or disks. There are also graphic output devices, such as pen, electro-static and color plotters.

2. Computer software

The computer can process the data fed into it (lying in the storage area), only if it is given a set of instructions, in a language that is intelligible to it. The set of instructions is known as the program. There are many languages available as interpreters and compilers to convert into machine language.

Computer architecture embraces the art and science of assembling logical elements into a computing device. The relationships between these components are shown in the

following diagram.

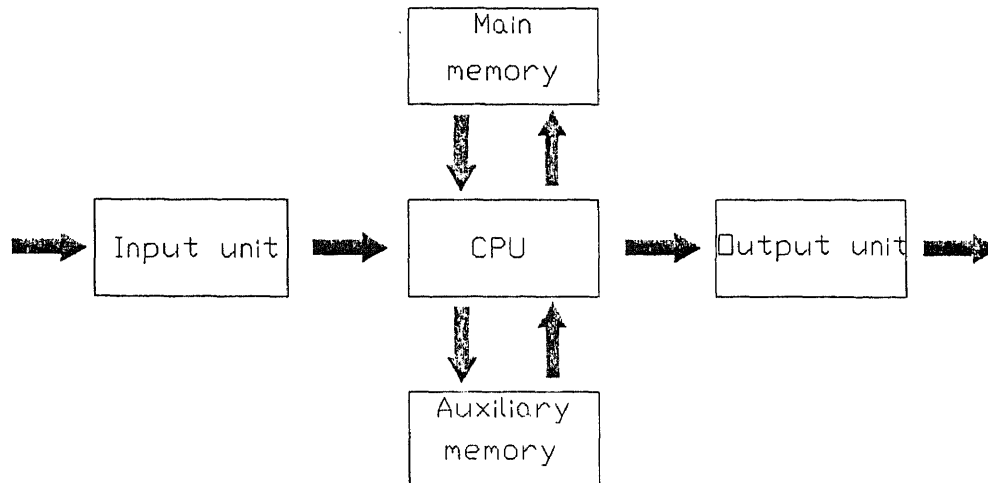

Figure 4 - 1. Relationships between elements of computer system

B. Office Technologies Systems

Computer related technologies which are used in offices will be introduced in this section.

1. Technologies

For an executive and an administrator's work, it is essential to have computers, video displays, micro film viewers, etc. For conference activities telecommunication

network technologies (local and satellite communication links) and audio-video teleconferencing facility instead of mailing, telephoning, and traveling are needed. They need video display terminal for long term management and sometimes need management oriented software.

In some case, computer aided design facilities are required for professionals. For secretaries, video display terminal, word processor, printers, telephone, dictation transcribers are needed instead of traditional typewriters.

2. Network systems

As described in previous computer section, to produce work faster and raise performance, computers use multi - programming, batch system, on line system, remote job entry system, real time processing, on-line real time and time sharing system, etc.

All of these systems are done through a network system which transmits data over communication lines, such as telephone lines or coaxial cables. An integrated network can combine devices as needed to fit an organization's needs.

Integration of systems and technology is a prime concern in new office buildings. Most new office buildings incorporate the newest technologies in HVAC, lighting,

communication, etc, to some extent.

Like following figure, a local area network (LAN) is a communication system that interconnects computers, terminals, and workstations in a limited geographic area.

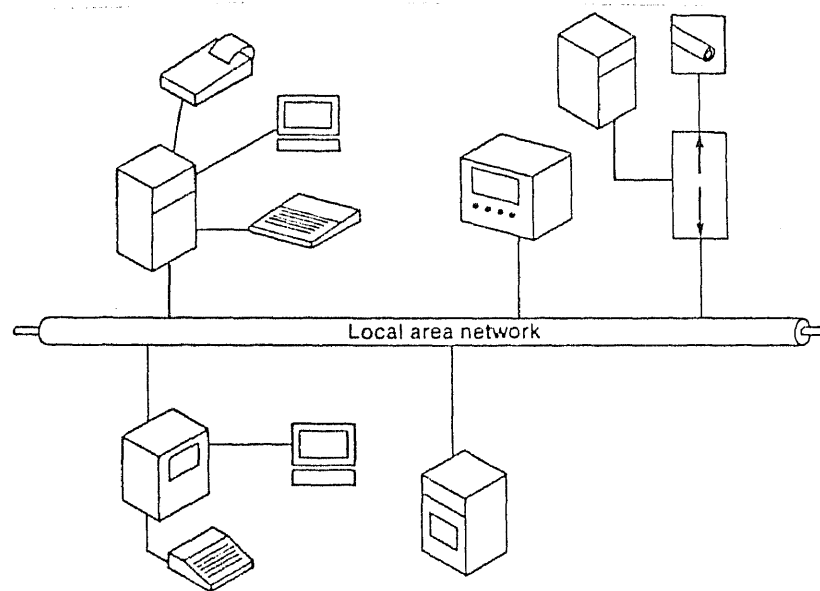

Figure 4 - 2. Local Area Network

These systems connect two or more buildings and cities. This modern network takes advantage of high speed digital lines, high speed satellites, microwave, and fiber optic circuits (Gouin, 1989, pp 91).

These systems initiate open office system which have movable wall panels of varying heights instead of complete walls with doors. This open system no more satisfies recent

office advanced technologies system since office activities are becoming more complex and need more advanced technologies.

3. Technologies according to three management systems

Technologies can be arranged as follows according to previous three management systems.

SYSTEMS	CHARACTER	TECHNOLOGIES	APPLICATION
Hierarchical system	one machine (air conditioner heater, radiator) for one system	thermometer humidifier watch (clock) ionizer pollution filter	traditional general buildings
Matrix system	functions or layouts of rooms are related with each other	HVAC telephone intercom	hospital laboratory
Network system	all rooms and equipments are connected by a network system through raised floors	computers modem, fax video text voice mail online dbase teleconference	microprocessor equipped buildings
Trend in network systems	integration of network systems and full automation	electronic nerve center, bio feedback sensors, laser lightshow equipment, wall sized projection T.V, receiver for direct broadcast	

Table 4 - 1. Technologies according to systems

C. Activities

An office is a place where people read, think, write, and communicate; where proposals are considered and plans are made; where money is collected and spent; where businesses and other organizations are managed.

In this section, by looking at activities of offices, a survey standard will be set up and the survey analysis will be more understandable.

There are two types of activities.

1. Daily activities

An executive and an administrator think and plan for decision making. They do writing, reading, electronic mailing, telephoning, referencing, and other job-related work. They order supervisor and secretaries to prepare for a meeting, seminar, or a conference.

Secretary may work for an individual or group of people. Secretaries are expected to perform approximately 100 different tasks in a week. They do typing, reporting, document writing, reading, storing, filing, collating, sorting paper documents, etc. Now many of these tasks are being handled by electronic equipment.

Recently, data typists do data entry, and programmers and data analyst do their special jobs. They need space to

accommodate writing, to display manuals, printouts, and large amounts of paper work.

These activities and the corresponding equipment are common in an office.

2. Long term activities

Usually, long term activities occur in a group or organization setting rather than as an individual activity. An executive or an administrator organizes a meeting by himself or by ordering secretary. And he attends a conference frequently or periodically.

CHAPTER V

CASE STUDIES

A. Survey

In this chapter, by finding out practical applications of advanced technologies in office buildings, relationships between computers and buildings will be examined.

The purpose of this case study is to find the organizational structure of the offices studied, and to determine their activity structures. From this, one can find the need for different technologies and levels of automation.

For the survey, the questionnaire technique was used

to collect data and interview and observation techniques were used as a supplement.

In surveys, the following companies and jobs were investigated.

1. Following is a summary of the main businesses and surveyed jobs.

a. Folio Inc. New York : (8 questionnaires)

Folio is a "converting" company. It buys market demandable designs and gives them fabric manufacturers to print those designs on fabrics. When this is done, the fabrics will be sold to garment makers through Folio.

Surveyed jobs are President (1), coordinator (3), accounting workers (3), receptionist (1).

b. I. B. M. New Jersey : (6 questionnaires)

IBM manufactures computers and computer related items.

Surveyed jobs are Vice president (1), section chief (2), designer (2), secretary (1).

- c. United Technology (Carrier). New York :
(10 questionnaires)

Carrier deals with air conditioners. It repairs malfunctioned air conditioners and resells them.

Surveyed jobs are Project leader (1), Engineer (3), technician (3), designer (2), secretary (1).

- d. Westing House. New Jersey : (9 questionnaires)

Westing House is basically composed of 3 departments. One department is for designing merchandise, one department is for its applications, and the last is for marketing.

Surveyed jobs are Vice president (1), engineer (4), designer (2), secretaries (2).

2. Survey contents

Questionnaire : see Appendix 1.

Survey period : Jan 29. 1990 - Mar 20. 1990.

For the analysis of the survey, jobs are classified as following:

*. Managers: They manage or supervise the execution of office activities. They make major decisions for the company. In this survey, president (1), vice president (2), and project leader (3) were included.

*. Technical personnel: They do specialized tasks while they help with manager's major tasks. Coordinators (3), engineers (7), accounting workers (3), technicians (3), and designers (6) were interviewed.

*. Secretaries: They handle correspondence and manage routine and detail work to help managers and support office worker's tasks. Secretaries (4) and receptionist (1) were interviewed in this study.

B. Analysis of Behavior related to Productivity.

1. Work space

Managers usually have their own private space which is approximately 150 - 300 square feet. Technical personnel share a single large space depending on the number of employees with a personal area of 50 - 100 square feet. Secretaries's work space is roughly same as general office worker's.

2. Major tasks and time spent

Manager's tasks are characterized as follows.

Reading	2 hours
Writing	1 hour
Thinking/ Conceptualizing	1 hour
Using a telephone	1 hour
Calculating	1 hour
Using a computer	1 hour

He does tasks directly related to decision making. Technical personnel's tasks vary considerably. They read, write, use a telephone, use a calculator, use a computer more than one hour. They spend lots of time according to their specialized tasks by doing documenting, drafting, using a computer, using a telephone. Secretaries spend their time writing, typing, mailing, storing, using a telephone. They also do different activities to support manager's or technical personnel's tasks.

These three main categories of jobs not only have their specialized tasks but are very closely related to each other.

3. Interactions per day and Communications

Intra departmental and inter departmental organization diagrams by jobs are shown in the following figures. Frequencies are per day.

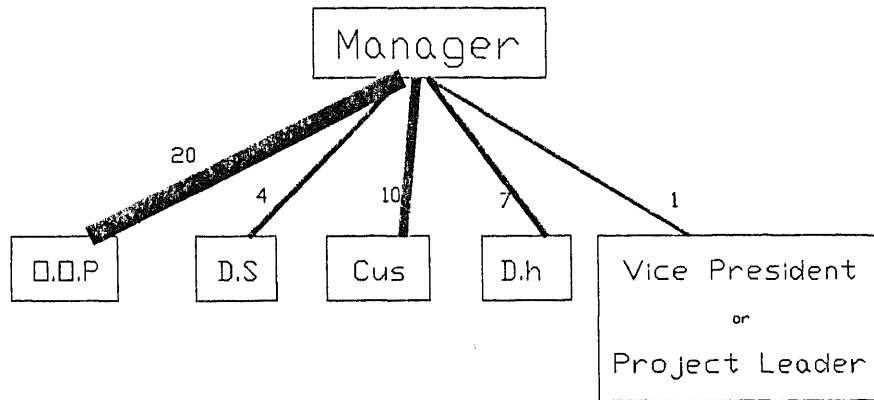

Figure 5 - 1. Intra departmental organization (manager)

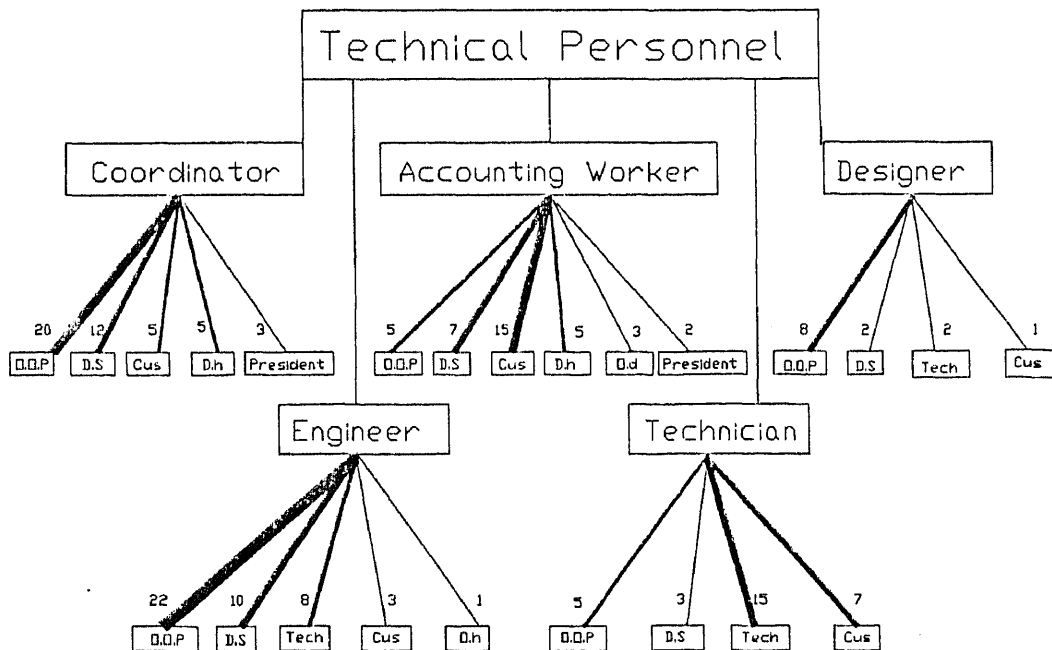

Figure 5 - 2. Intra departmental organization

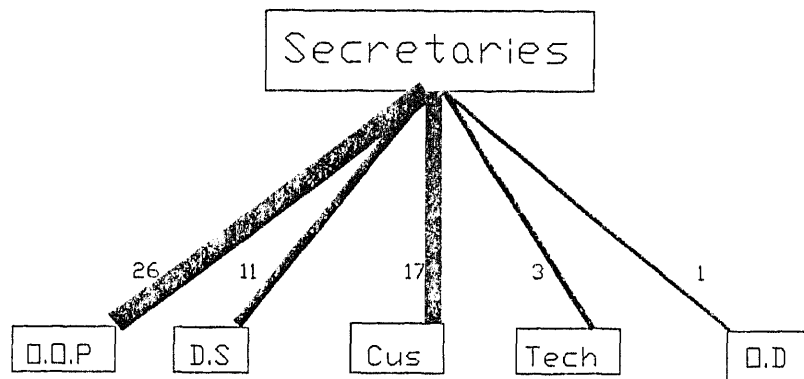

Figure 5 - 3. Intra departmental organization

*. Legend for figure 5 - 1, 5 - 2, 5 - 3.

-
- O.O.P : own office personnel (secretaries etc.)
 - D.S : direct supervisor Cus : customers
 - D.H : department head Pre : president
 - O.D.H : other department head
-

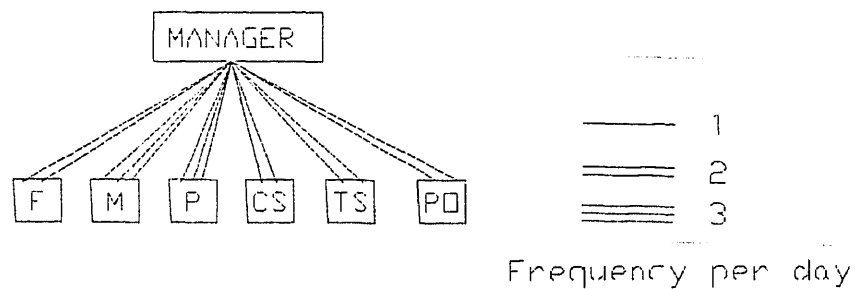

Figure 5 - 4. Inter departmental organization

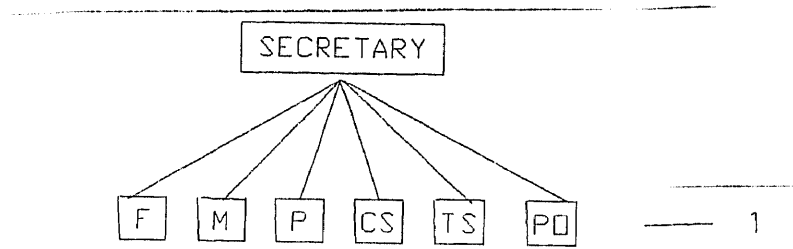

Figure 5 - 5. Inter departmental organization

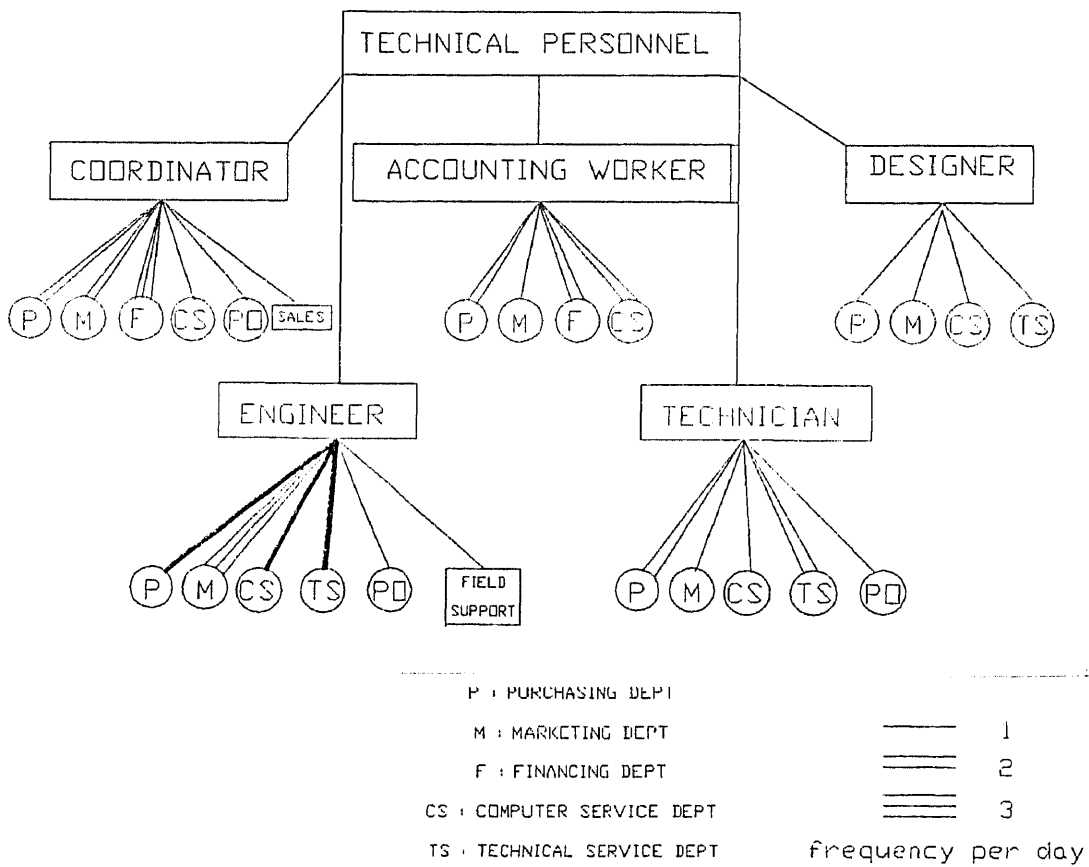

Figure 5 - 6. Inter departmental organization

Legend for figure 5 - 4, 5 - 5, and 5 - 6.

 F : financing department P : purchasing department
 M : marketing department P.O : personal office
 C.S : computer service department
 T.S : technical support (repairs)

Managers meet with their own office personnel more than 20 times per day and meet with their direct supervisor, customers, and department head many times a day. By the nature of his work, the manager actually contacts the whole department because he administers the whole office.

Technical personnel meet with the office personnel continuously (more than 10 times average), direct supervisor more than 3 times, and customers clients, technicians, co-workers occasionally. There are big differences between the frequencies of the contacts because of their specialized work (figure 5 - 3).

They contact other departments like finance, technical, purchasing, word processing administrative services, sales department, and field support department to meet their specialized tasks (figure 5 - 6).

Secretaries frequently interact with their own office personnel and with clients directly, and customers by phone. Because other department personnel have to contact president

via his secretary, secretaries contact most other departments directly or indirectly by need or request.

Comprehensive intra and inter departmental organization diagrams are as follows.

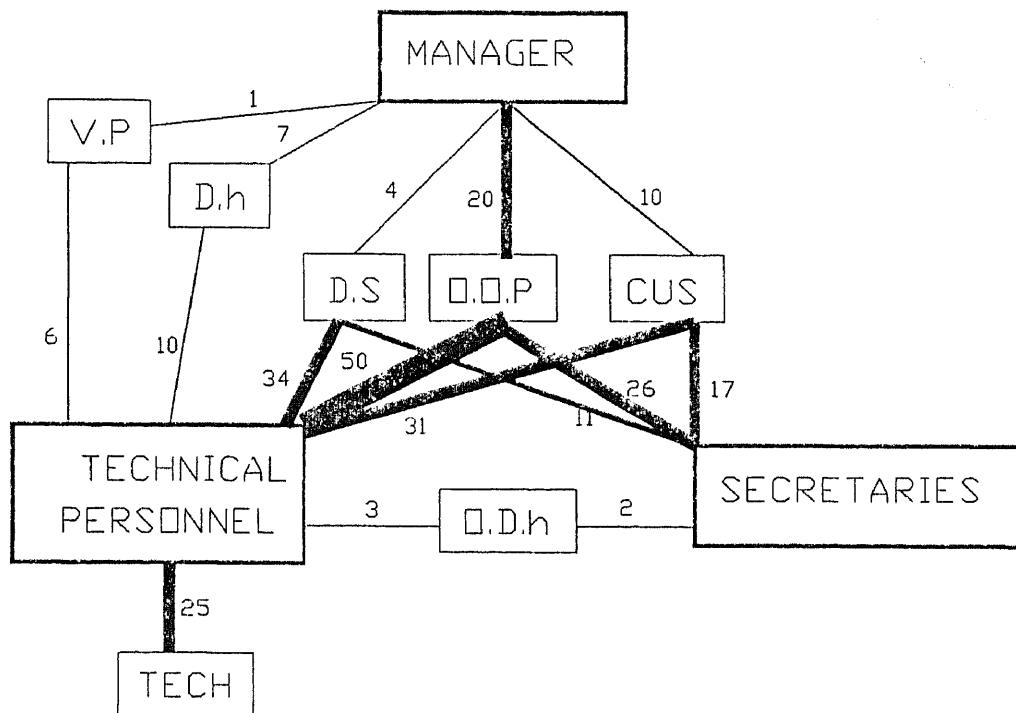

Figure 5 - 7. A comprehensive intra departmental organization

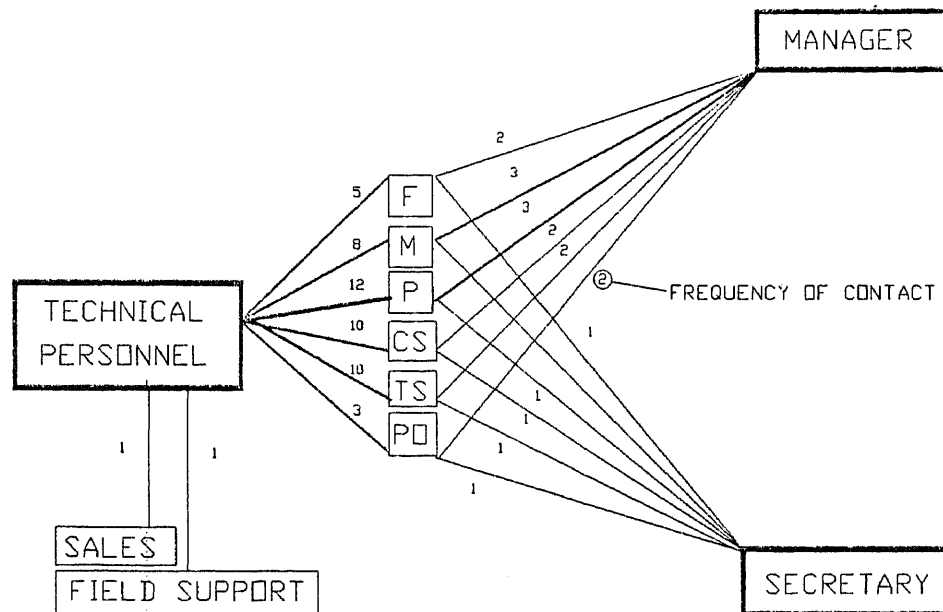

Figure 5 - 8. A comprehensive inter departmental organization

For communication, managers use the telephone the most and intercom and fax the next most. They seldom walk and personally contact people for communication. Technical personnel usually walk and directly contact co-workers for task performance.

They communicate with the outside by using the telephone, by mail or by using the fax machine. Secretaries mainly use telephone and intercom for communication inside the company and use telephone, fax machine and computer to communicate with the outside.

Futhermore, as we can see in figure 5 - 7 , managers,

technical personnel, and secretaries' interactions with their direct supervisor, their own office personnel, and customers, usually take place within the office. Therefore they simply use the intercom, or directly talk for communication.

During inter departmental communication, they contact purchasing departments, computer service departments, and technical service departments many times, which considerably affect their task performance (figure 5 - 8). They usually use telephone, intercom, and fax machine for inter departmental communication. They seldom contact directly. This indicates, for inter departmental communication, that they need a better automation system for communication.

The relationship and methods of communication are shown in the following figure.

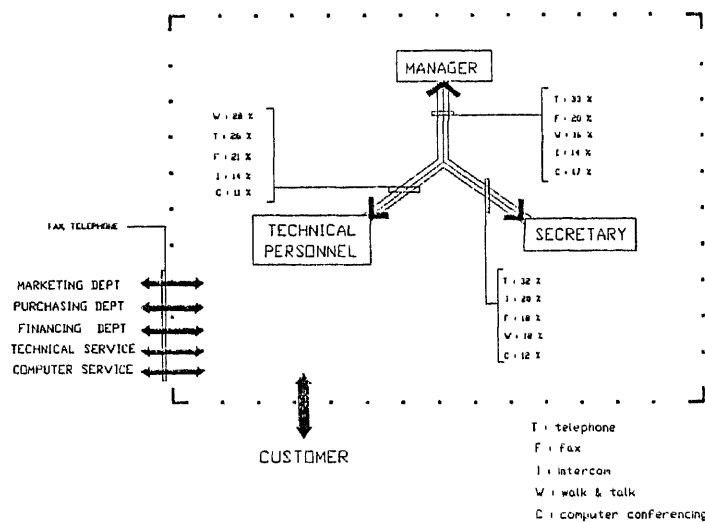

Figure 5 - 9. Methods of communication

The main characteristic of communication is that employees use technical services (computer conferencing, fax, etc.) if they are equipped. Unless they have technical services, the high-tech services are replaced by direct contact or telephoning.

5. Meetings per week

Only managers and technical personnel participate in meetings held 1 or 2 times per week. Secretaries do not attend these meetings. This is because meetings have direct correlation with the actual business attended. Currently, they use audio-visuals and conferencing calls as advanced technologies at these meetings.

C. Analysis of Technologies

Managers use the telephone the most and they simply have a personal computer, a personal printer, and share other facilities with employees. Technical personnel use equipment as follows:

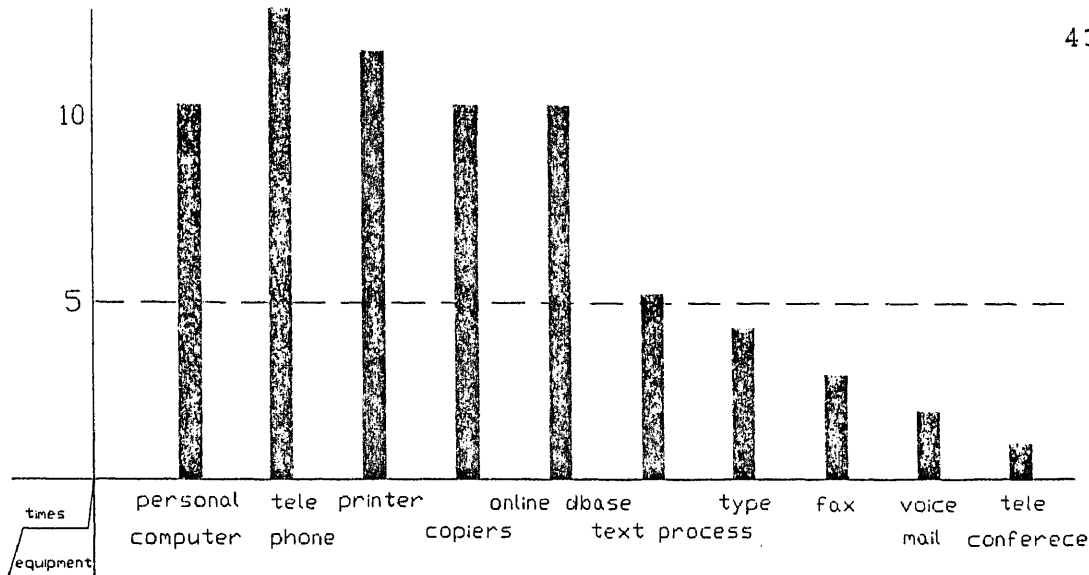

Figure 5 - 10. Equipment use per day (technical personnel)

Technical personnel raise the efficiency of work by using various equipments. In the above figure, the machines that are used continuously are those scaled above 5. The following figure shows the times of equipment which are used by secretaries.

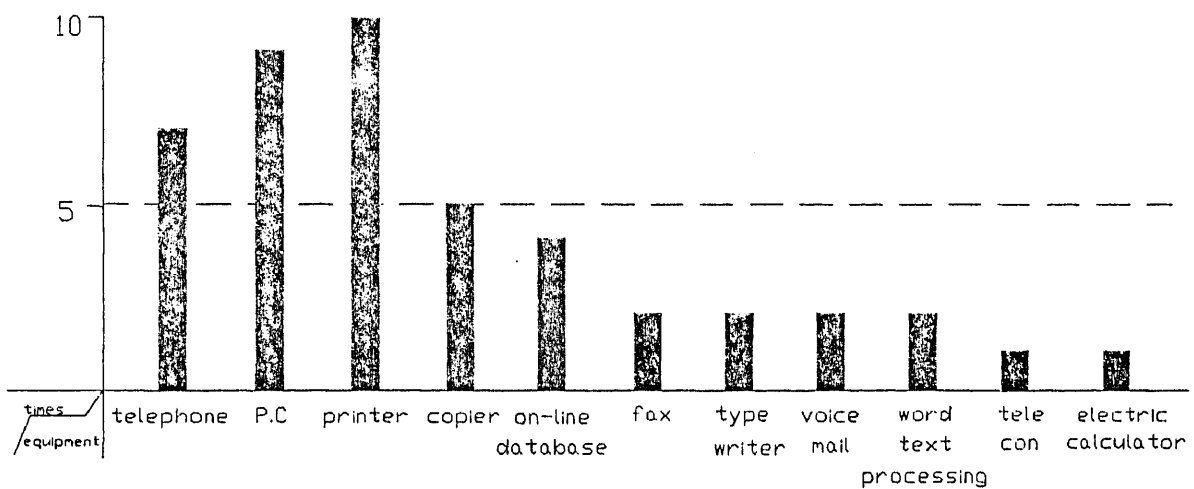

Figure 5 - 11. Equipment use per day (secretary)

They support the president and other employees by using telephone, personal computers, printer, on line database, and copiers. In the above figure, the equipments that have a frequency of usage of above 10 are accepted to be used continuously.

All equipment are shared by employees except personal computers and telephone. Most employees want to have the following equipments to raise productivity.

- *. Better computer
- *. File system (more software capabilities)
- *. Private printer/ plotter (to save time by
immediate access)

In the one sixth of survey answers those surveyed want printer for personal use. It is the item highest in demand and others want to have televised telephone and color printer.

Following table shows equipment distribution according to work space.

Space\ Equipment	Existing Equipment	Needed Equipment
Manager's space	telephone, P.C, printer, word & text processing, voice electronic mail, fax, copiers, teleconferencing facilities.	better computer data base
Technical personnel's space	co-ordinator: telephone, typewriter, P.C, printer, fax, copier, word & text processing, voice electronic mail, online database, teleconferencing facilities.	
	accounting worker: telephone, typewriter, P.C, printer, fax, copier, word & text processing, online database, electronic calculator.	
	engineer: telephone, P.C, printer, fax, copier, online database, word & text processing, voice electronic mail, teleconferencing facilities.	
	technician: telephone, P.C, copier, fax, printer, online database.	
	designer: telephone, P.C, copier, printer, fax.	
Secretary's space	telephone, typewriter, P.C, word & text processing, printer, copier, online dbase, voice & electronic mail, teleconferencing facilities.	televised telephone personal printer

Space\ Equipment	Existing Equipment	Needed Equipment
Common space	co-ordinator: telephone, typewriter, P.C, word & text processing, fax, copier.	P.C (more software capabilities
	accounting worker: typewriter, fax, printer, online dbase, copier.	large space
	engineer: printer, fax, copier, voice & electronic mail, online database, teleconferencing facilities.	private printer fixed rest time & place
	designer: telephone, copier, fax, printer.	
	secretaries: fax, copier, printer.	better computer

Table 5 - 1. Equipment distribution

2. Software

Managers mainly use word processing and DBASE. Technical personnel use various kinds of software according to their job. They use word processing, accounting program, DBASE, micro soft windows, DOS, Turbo Pascal, Lotus, Freelance, Switchlan, Noitor, Paradox, PC 5001S, Framework II, Lotus 1,2,3, etc.

Secretaries mainly use word processing.

3. Equipment support.

Managers are generally well equipped to perform their work and so does the technical personnel. Each person has his or her own telephone, computer, typewriter near by, but they share copiers, printers, fax machine which are usually placed in a distant common space.

D. Quality of Space

1. Space

Technical personnel think they have adequate space to support the required work load. But when the quantity of work is increased, they need larger space. However they think they need a little bigger space to be more productive.

Because secretaries' work spaces are located in open public space, they have good access to equipment, but it is generally noisy because of many visitors and machine generated noise (copiers, printers, etc.)

2. Privacy

Managers think their workspace support privacy pretty well both acoustically and visually. But most of technical personnel are not satisfied with their privacy, especially

acoustically.

Usually most of the noise is from people (other workers who are talking, working in near areas, or standing nearby and having a meeting). Other noise is from nearby printers or copy machines. Secretaries are not satisfied with their environment, because generally their workspaces are not surrounded by walls or have too many doors.

3. The most important feature

Managers choose ventilation, a comfortable temperature, and windows as important environmental features. Technical personnel want general improvements in all features such as window, light, noise, temperature, ventilation, and technology. Secretaries demand better technologies, noise reduction, and ventilation. The following are the generally demanded features of an office.

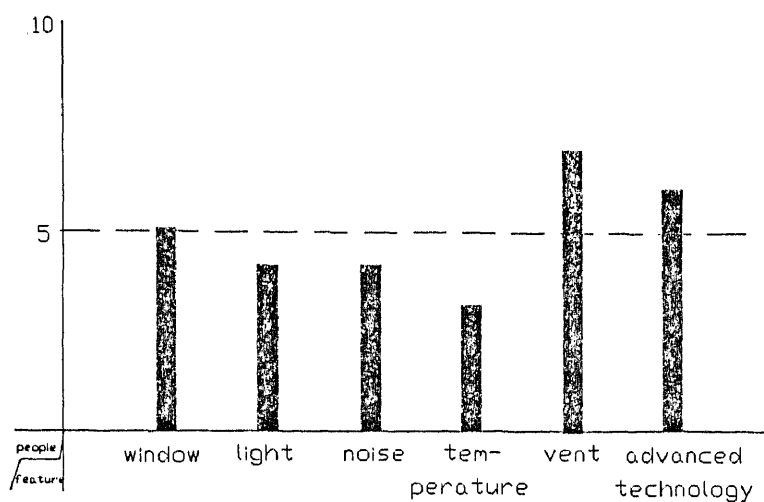

Figure 5 - 12. Demanded features of an office

Technical facilities are an important feature to have in an office when technologies are compared with other environmental features. In comparing technologies with ventilation and window, it can be seen that employees think better technological facilities are an important feature to have in an office.

4. Environmental characteristics of an office

General characteristics of three main jobs are shown in figure 5 - 13.

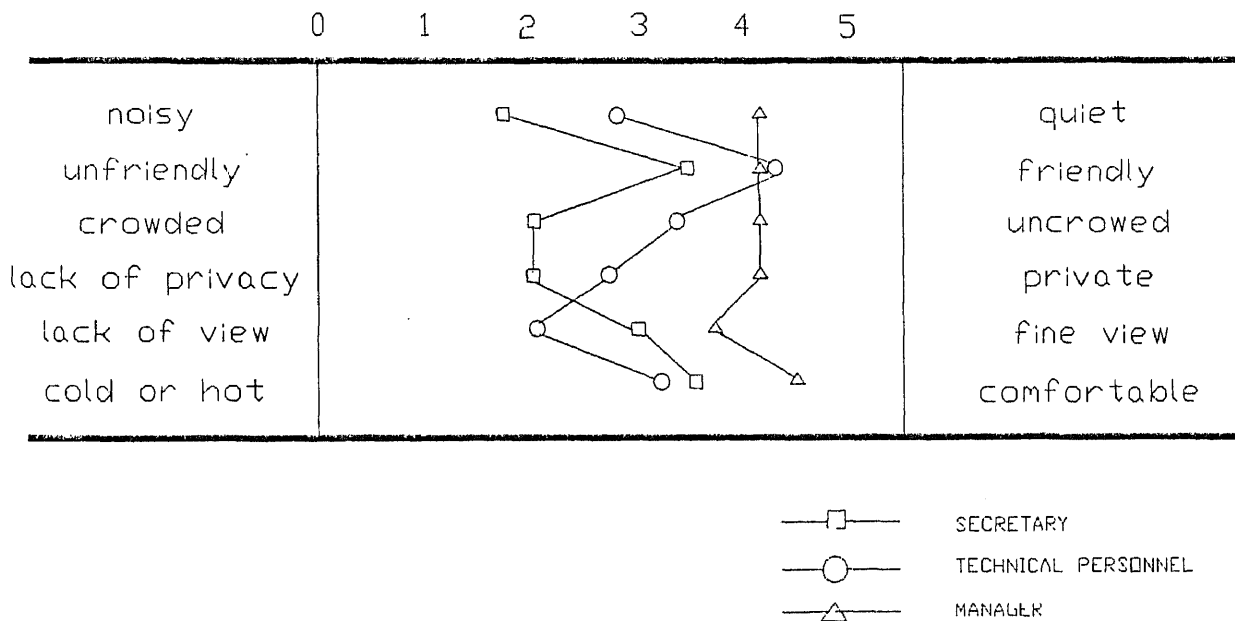

Figure 5 - 13. General characteristics in an office

Manager's satisfaction is higher than technical personnel's and secretary's. This is because he has his own office space which gives privacy from noise and other people.

Technical personnel and secretaries' environmental satisfaction are very similar except for noise and friendliness. Technical personnel's friendliness is highest because they share the space. Sharing a space gives people a chance to interact more and creates a better work atmosphere.

5. Lunch and rest

Employees have their lunch at a near by restaurant or at their own desk. But in a big company which has a company cafeteria, employees seldom eat out (eg, Carrier).

Employees spare their lunch time and rest after lunch. They make occasional quick trips to make a cup of tea or visit the rest room. They want a fixed rest time and place which has a coffee machine and light music to increase their work efficiency.

CHAPTER VI

GUIDELINES FOR ARCHITECTURAL DESIGN

A revolution in buildings is occurring as we are entering the age of the advanced technology. Also advanced technologies are a key for building efficiency and worker productivity. The future society will become a technology oriented society, mainly in new communication technologies. The office environment is changing by the second. Its size, location, and shape, its personnel structure, its spatial and building system requirements are influenced by developments in electronic technology.

The improvements of advanced technology systems are expected to supplement rather than radically change existing planning concepts and the shapes and configurations of

architectural design. With the advent of the micro computer came opportunity to change the way people do office work, and in turn, how buildings must be designed. Now there are new demands on building features and environmental services.

According to previous chapters, some points to consider will be suggested in this chapter when designing office buildings.

A. Work Space and Privacy

Managers usually have their own private space. They think their work space support privacy pretty well both visually and acoustically while technical personnel and secretaries do not. To do more work, technical personnel want larger space and secretaries need enclosed space with walls from noise because most of the noise is from people and nearby printers or copy machines.

Workstations and enclosed office entrances should not be directly across from one another, but staggered to avoid direct sound paths. Also a single loaded corridor tends to be quieter than almost any other layout shape, because people are not in close juxtaposition to one another (Cohen, 1983, pp 233).

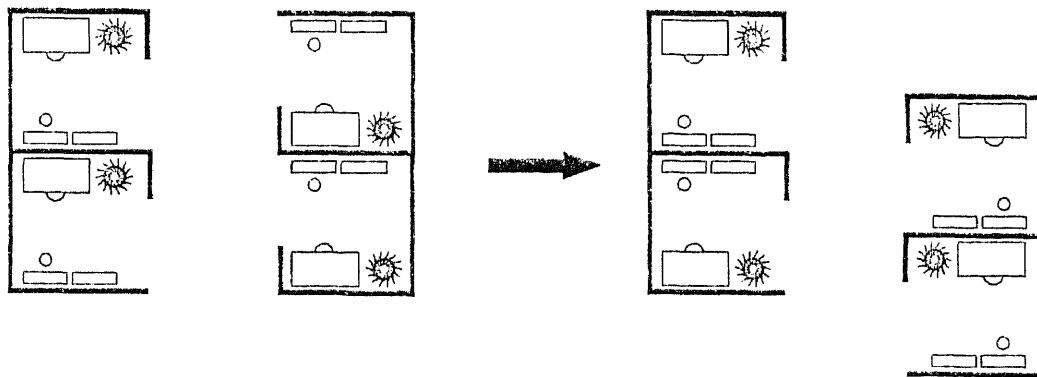

BEFORE

AFTER

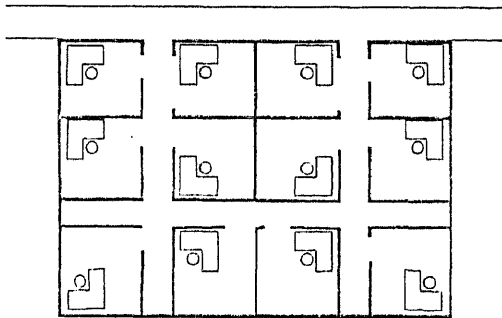

BEFORE

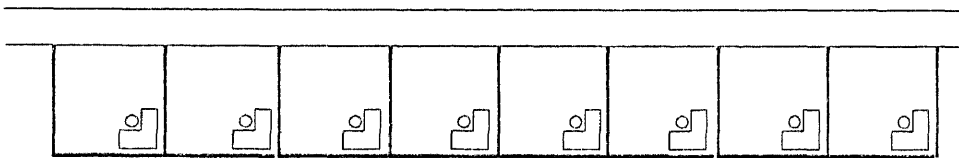

AFTER

Figure 6 - 1. Space layout

While keeping individual employee's space away from noise and other eyes, creating a more friendly work atmosphere is a major factor for raising productivity.

Typewriter, keyboard, or similar equipment are aggravated by the addition of disk drivers, impact printers, plotters, and various keying operation. These maybe controlled by the following procedures (William, 1988, pp 94).

- *. Acoustic hoods designed to fit around and over noise generating equipment.
- *. Locating extremely noise generating equipment in separate areas removed from general activity.
- *. Enclosing equipment in full height partitioned spaces that have been properly constructed and sealed to prevent sound transmission.

Until now, printers typically contain high-absorption, peak and valley acoustical foam, cooling fans, and clear plastic covers. This printer closet effectively and aesthetically controls the printer generated noise. Noisy impact printers may soon be forgotton with the advent of personal laser printers (Cohen, 1983, pp 178).

B. Task and Equipment Support to the Task

Manager does tasks directly related to decision making. Technical personnel do their specialized tasks by using various equipments. Although all workers have their

own equipment such as telephone, computer, typewriter nearby, they share copiers, printers, fax machines which are usually at a distance. Technical personnel and secretaries mainly share printers, copiers, and fax machines. Preparing an adequate space which supports this equipment nearby is required.

Following is the equipment distribution table.

Title of space	Equipment
Manager	telephone, P.C, personal printer
Technical personnel	
coordinator	share all equipment
accounting	share all except telephone & P.C.
engineer	share all except telephone & P.C.
technician	share all equipment
designer	share all except P.C.
Secretary	telephone, P.C, typewriter, text processor.
Public space	FAX, COPIER, PRINTER, telephone, typewriter, P.C, Dbase, word-text processor, voice-electronic mail, teleconferencing facilities.

Table 6 - 1. Existing equipment distribution

Accounting workers and engineers are equipped with only a telephone and a P.C. Designers are equipped with a P.C. only. Except for the telephone and the P.C, almost all equipment is shared by all employees.

Considering the frequency of using each equipment, the following equipment should be provided to each employee.

Employee	Private Equipments
coordinator	telephone, copier, fax, printer, typewriter (used more than 3 times a day)
accounting	telephone, P.C, printer, copier
engineer	telephone, P.C, printer, copier voice-electronic mail
designer	P.C

Table 6 - 2. Minimum desirable equipment

Other equipment should be located in a close-by place to share with technicians and secretaries.

The reason to have a personal printer is to reduce time and walking distance to a shared printer. Placing the printer in a nearby place or giving them a private printer is the best solution. Most of the employees want to have a better computer system, and software capabilities for

better productivity, private printer for immediate access.
(see chapter V).

The following is a comprehensive space relationship table according to the frequency of meeting during intra and inter departmental relationships.

	Intra department					Inter department					
	O.O.P	D.S	CUS	D.H	Tech	F	P	M	Cs	Ts	Po
Manager	7	2	5	5	1	1	2	2	1	1	1
Co-ordinator	10	10	3	5	.	3	2	2	1	1	1
Account worker	5	7	8	5	.	2	2	1	2	.	.
Engineer	6	2	3	.	2	.	3	1	2	2	.
Designer	2	1	1	.	1	2
Technician	3	2	4	.	9	.	2	2	2	2	.
Secretary	10	6	4	.	.	1	1	1	2	2	1

O.O.P : Own Office Personnel D.S : Direct Supervisor
 CUS : Customer D.H : Department Head Tech : Technician
 F : Financing P : Purchasing M : Marketing
 Cs : Computer Service Ts : Technical Service
 Po : Personal Office

Figure 6 - 2. Comprehensive space relationship

In intra- departmental relationships which require much direct contact, there is a need for a public space

which contains many kinds of rooms like service room, meeting room, conferencing room in a short walking distance. Especially technical personnel walk more than the manager or secretaries who use the telephone and the intercom comparatively more, therefore the rooms of technical personnel should be located near common technical space.

In the inter-departmental relationships, people seldom walk for correspondence. This indicates full automation in the inter departmental contacts.

C. Communications and Meetings

Suggested space relationship diagram is as follows considering the interactions and the equipment usage.

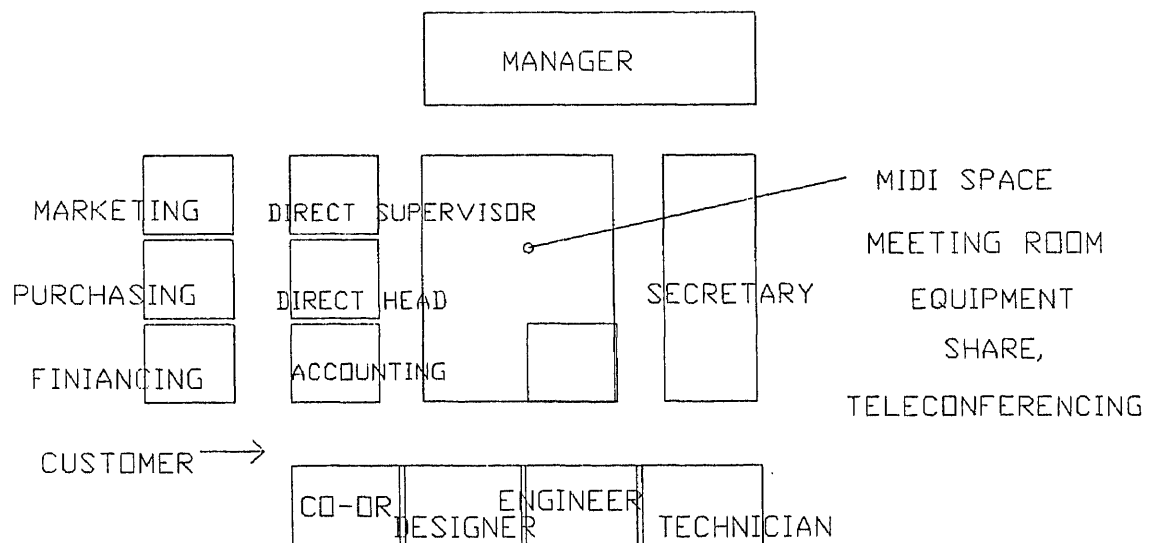

Figure 6 - 3. Space relationship

Micro spaces like each employee's working unit have to be grouped together according to their relationships, and public spaces offer needed facilities like meeting room, shared equipment room, teleconferencing room, etc.

In the teleconferencing room, instead of relying on audio communications and paper transmittals, organizations can apply two way visual contact to achieve a more personal and effective exchange of information and direction. They no longer sit facing each other around a table, but sit facing the wall watching the screen. The furniture layout need to be changed.

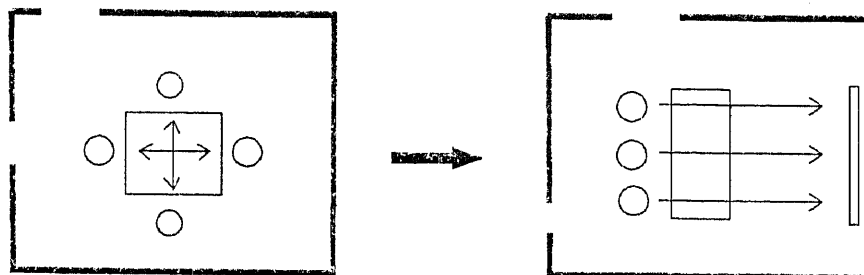

Figure 6 - 4 . A change of visual contact

D. Flexibility of Space

As automation is introduced into offices, movement of people and data are affected by it. Employees are now beginning to feel the necessity for more advanced

technologies, for they need more contact with other employees or departments, and they need more data and data exchange.

Therefore, it is hard to do current office work within old fashioned hierarchical or matrix system.

Managerial system and equipment network system are still based on hierarchy or matrix. The handling of information is not productive any more. This way of looking at things (which may have been appropriate in hierarchical and matrix system) persist in network system now.

By the nature of the work, almost all of today's work have to deal with network systems. If the office wants to be effective, the organization system must be effective.

As the most important thing in computer is the speed and the accuracy, when we design a building, like computer, making people's travel distance short is required. Because within a limited time, quick information exchange and a lot of communication are required, we need to think about the space which requires little movement. It means every space has flexibility to meet variable situation as well as its own function. Here the network system is strongly recommended. Also the best approach to anticipate change is to plan space with flexibility as much as possible.

E. A Virtual Office

As we saw in previous chapters, the improvement of productivity in offices depends largely on all the advanced technologies of network systems.

The nature of the office is transformed. There is no longer a need to assemble workers at the same place and at the same time. Portable terminals and computers, equipped with appropriate software and facilities for communication (including telephone) create a virtual office, a remote workstation which is anywhere the worker happens to be. This remote work station can communicate electronically with the central office, and so it extends the range of places where written and numerical material can be generated, stored, retrieved, manipulated, or communicated.

Now the work stations and electronic devices of an automated office can be linked to external terminals and personal computers. The job is tied to the worker himself. The individual can organize his own time and decide where and when he wants to do his work. Most of the messages can be generated outside of offices and outside of conventional working hours.

In this case, every office room does not need to be in the same building because of this flexibility to generate work outside the office space.

But we should not neglect the psychological and social changes which may be caused by less contact and more electronic equipments.

F. Other Considerations

Most technical personnel and secretaries wanted to have a fixed rest time and place. For convenience, paper reproduction rooms are also required. These are localized into convenient service areas for the occupant's use considering problems relating to odors, noise.

G. Summary of Properties

The following is a list of proposed properties of building systems which have been discussed earlier.

1. Privacy : Employee need enclosed space with walls from noise.
2. Acoustics and noise control :
 - *. entrances should staggered
 - *. a single loaded corridor (see figure 6 - 1)
 - *. locating noise generating equipment in a separate area
 - *. acoustic hoods or enclosing equipment (partitioned spaces)

3. Proximity to common equipment

Employee share main printer, copiers, and fax machines. The placing of common equipment at a near by location in an office is required (see pp 58).

In intra-departmental relationships, there is a need for a public space in a short walking distance. In inter-departmental relationships, full automation is needed because employee mainly use equipment for contact.

4. Distribution of private vs. common equipment and its effect on relationship of spaces.

The equipment that should be provided for each employee is seen in table 6 - 2, and common equipment is illustrated at table 6 - 1.

5. Flexibility in the use of space : All of today's work have to deal with network systems. Within a limited time, quick information exchange and a lot of communication are required. We need to think about the space which requires little movement. Making employee's travel distance short is required. In spatial system, network system which requires less movement to make more frequent contact to other departments is needed. Modern buildings depend on communication systems for normal functioning. For communication, employees use network systems and want more advanced technology systems inside and outside the office.

6. Interior space arrangement

Interior design issues for advanced technology need to be changed. In conferencing room, organizations can apply two way visual contact to achieve a more personal and effective exchange of information (see figure 6 - 4).

Micro spaces like each employee's working unit have to be grouped together for easy contact.

7. Impact of technologies on social and psychological aspects

Now spatial system designer has to be concerned with social and psychological aspects of human due to decreased contact and more electronic equipments.

More need for spaces to be used for social interaction like lobby, rest area. Separate spaces for remote office worker are needed. To raise productivity additional activities and organized activities are needed.

APPENDIX 1

Questionnaire

Personnel

Department _____ Job title _____

Work space _____ square feet

Behavior for Productivity

* What tasks do you perform? Please circle them.

reading writing mailing filing typing
using a telephone using a calculator
using a computer using a wordprocessor
reporting documenting storing meeting
sorting/collating thinking/conceptualizing
dictating into a transcriber drafting
other

* How many hours a day, on average, are spent at the workspace doing the following:

example) typing 3 hrs

Writing _____ Reading _____

Using a telephone _____ Using a calculator _____

Using a computer _____ Using a word processor _____

Mailing _____ Documenting _____

Reporting ----- Storing -----
 Filing ----- Typing -----
 Meeting/conferencing -----
 Dictating into a transcriber -----
 Thinking / conceptualizing -----
 Sorting/collating ----- Drafting -----
 Other -----
 Total hours per day at your workstation -----

* How many direct interactions or exchanges per day occur with the following people in your job?

Own office personnel (secretaries etc.)

 Direct supervisor ----- Custodians/Technicians
 Customers ----- Clients ----- Dept. Head
 President ----- Other Dept. Heads
 Other -----

* What other departments do you contact?

----- Finance ----- Purchasing ----- Marketing
 ----- Computer Services ----- Technical Support(repairs)
 ----- Personal Office
 ----- Other

* Please rank the following methods of communication in the order of frequency (1-most often 5-least often)

() by walking and talking () by using telephone
 () by using intercom () by facsimile
 () by computer conferencing
 () other -----

* How many meetings do you attend per week in your office?

1) 1 2) 2--5 3) 6--10 4) other -----

* Do you use any advanced technologies at the meeting? If yes, list them.

Relating to Technology

- * Please indicate how many times you use the following equipments next to each item. Place an "X" next to the number you specified if you share the equipment with others on a continuous basis. Leave blank if not used.

telephone, typewriter, personal computer
 ----- ----- -----
 word & text processing, voice or electronic mail
 ----- -----
 printer or plotter, online database access
 ----- -----
 teleconferencing facilities, facsimile
 ----- -----
 copiers, video tex
 ----- -----
 other -----

- * What other equipments would you like to have ? Why?

- * What kind of computer software do you use?

1) word processing 2) accounting 3) CAD
 4) DBASE (spread sheet) 5) other -----

* When and where do you have lunch and take rest ?

lunch; time _____ place _____

rest; time _____ place _____

* Additional comments ?

APPENDIX 2

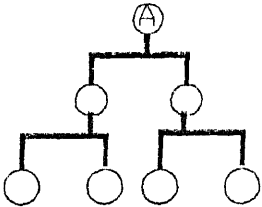
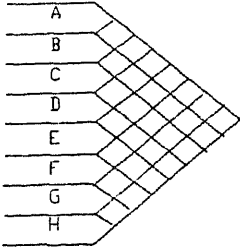
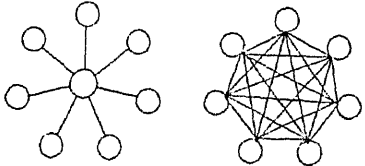
	Hierarchical	Matrix	Network
system characteristics			
variables	1 simple	2 or 3 simple-minded	n chaotic
technological characteristics	1 machine for 1 system	everything follows a series of flow	connected by network system
building system	traditional HVAC system		LAN system
technologies	thermometer humidifier pollution filter	telephone intercom	computer modem facsimile online database
example	traditional building	hospital laboratory	microprocessor equipped bldg

BIBLIOGRAPHY

- ANTHONY RADFORD AND GARRY STEVENS, CADD MADE EASY,
McGRAW HILL BOOK COMPANY. 1987.
- ARCHITECTURAL AND ENGINEERING SYSTEMS, VOLUME 5. NUMBER II,
MEDIACOM, INC., FORT COLLINS, CO. NOV.1989.
- ARCHITECTURAL TECHNOLOGY, SMART BUILDING, MAR/APR 1986
- ARTHUR H.ROSENFELT, SMART METERS AND SPOT PRICING:
EXPERIMENTS AND POTENTIAL, IEEE TECHNOLOGY AND
SOCIETY MAGAZINE . MARCH. 1986
- BUSINESS WEEK, A McGRAW-HILL PUBLICATION, JAN 8, 1990
- CaDalyst, CaDalyst PUBLICATIONS LTD, BELLINGHAM, WA, JAN, 1990
- CENTER, BUILDINGS AND REALITY; ARCHITECTURE IN THE AGE OF
INFORMATION, THE UNIVERSITY OF TEXAS AT AUSTIN, 1988.
- COLIN DAVIES, HIGH TECH ARCHITECTURE, RIZZOLI INTERNATIONAL
PUBLICATIONS, INC. 1988.
- DANIEL L. RYAN, COMPUTER - AIDED ARCHITECTURAL GRAPHICS,
NEW YORK , BASEL; MARCEL DEKKER, INC. 1983
- ELAINE COHEN & AARON COHEN, PLANNING THE ELECTRONIC OFFICE,
McGRAW HILL BOOK COMPANY. 1983.

- ELENA MARCHESO MORENO, COMPUTERIZED CONTROL SYSTEMS,
ARCHITECTURE, MAR. 1989.
- ENERGY USER NEWS, OWNERS, DEVELOPEERS URGED TO RETHINK
INTELLIGENT BUILDINGS, JUNE 8. 1987
- EZRA D. EHRENKRANTZ, ARCHITECTURAL SYSTEMS : A NEEDS,
RESOURCES, AND DESIGN APPROACH, MCGRAW HILL PUBLISHING
COMPANY, NEW YORK, 1989
- FORREST WILSON, A TIME OF RELENTLESS; TECHNOLOGICAL CHANGE,
ARCHITECTURE (p115-119), DECEMBER.1987.
- FRANCIS D.K. CHING, FORM. SPACE AND ORDER, VAN NOSTRAND
REINHOLD COMPANY INC, NEW YORK, 1979
- FRANK BLACKLER AND DAVID OBORNE, INFORMATION TECHNOLOGY &
PEOPLE : DESIGNING FOR THE FUTURE, THE BRITISH
PSYCHOLOGICAL SOCIETY, 1987
- FRANK CHING, ARCHITECTURAL GRAPHICS, VAN NOSTRAND REINHOLD
COMPANY INC. 1975
- GEOFF SIMONS, ECO-COMPUTER, THE IMPACT OF GLOBAL
INTELLIGENCE, JOHN WILEY & SONS LTD. 1987
- GERHARD SCHMITT, MICROCOMPUTER AIDED DESIGN, JOHN WILEY &
SONS, INC. NEW YORK, 1988

GLOBAL ARCHITECTURE DOCUMENT 16, THE HONGKONG AND SHANGHAI
BANKING CORPORATION, A.D.A.EDITA TOKYO CO., LTD.

NOV. 1986.

IANN BARRON AND RAY CURNOW, THE FUTURE WITH MICROELECTRONICS
NICHOLS PUBLISHING CO, NEW YORK, 1979

JEFFREY M.HAMMER, FACILITY MANAGEMENT SYSTEMS, VAN NOSTRAND
REINHOLD COMPANY INC. 1988.

JOHN PATERSON, ARCHITECTURE AND MICROPROCESSOR, JOHN WILEY
& SONS, 1980.

HERBERT A.SIMON, THE SCIENCES OF THE ARTIFICIAL, THE MIT
PRESS, 1985.

HERB BRODY, COMPANIES STRUGGLE TO AUTOMATE HOMES, HIGH
TECHNOLOGY BUSINESS, MARCH.1988

LINDA RAE MARKERT, CONTEMPORARY TECHNOLOGY, ILLINOIS.
THE GOOD HEART WILLCOX COMPANY, INC. 1989.

MANNEL CASTELLS, HIGH TECHNOLOGY, SPACE, AND SOCIETY,
SAGE PUBLICATIONS, 1985.

MARK LAUDEN CROSLY, THE ARCHITECT'S GUIDE TO COMPUTER
AIDED DESIGN, JOHN WILEY & SONS, INC, 1988.

MICHAEL ANDREWS, COMPUTER ORGANIZATION, COMPUTER SCIENCE
PRESS INC. 1987.

MICHAEL F. HORDESKY, CAD/ CAM TECHNIQUES, RESTON, VIRGINIA;
RESTON PUBLISHING COMPANY, INC. 1986.

MICHAEL WINN, ARCHITECTRONICS, MCGRAW HILL BOOK COMPANY, 1987

MICHELLE D. GOUIN, INTELLIGENT BUILDINGS, DOW JONES IRWIN,
1986.

NATIONAL AERONAUTICS AND SPACE ADMINISTRATION, LESSONS OF
THE HIGH TECH HOUSE, SCIENTIFIC & TECHNICAL
INFORMATION BRANCH, 1980.

NATALIE LANGUE LEIGHTON, COMPUTERS IN THE ARCHITECTURAL
OFFICE, VAN NOSTRAND REINHOLD COMPANY INC. 1984.

PIERRE GOUMAIN, HIGH-TECHNOLOGY WORKPLACES, VAN NOSTRAND
REINHOLD, 1989.

PROCESS 70, FOSTER TOWER; HONGKONG BANK, PROCESS
ARCHITECTURE PUBLISHING CO., LTD., TOKYO. APRIL 1989.

PROGRESSIVE ARCHITECTURE, HIGH-TECH ENVIRONMENTAL CONTROL
SYSTEMS, OCTOBER. 1985.

RANI LUEDER, THE ERGONOMICS PAYOFF, NICHOLS PUBLISHING
COMPANY, 1986.

RALPH LEE SMITH, SMART HOUSE, GP PUBLISHING, INC. MARYLAND,
1988.

- R.A. REYNOLDS, COMPUTING FOR ARCHITECTS, BUTTERWORTH & CO LTD, 1987.
- RICHARD D. RUSH, AIA EDITOR, THE BUILDING SYSTEMS INTEGRATION HANDBOOK, THE AMERICAN INSTITUTE OF ARCHITECTS, JOHN WILEY & SONS, NEW YORK, 1986
- ROB KRIER, ELEMENTS OF ARCHITECTURE, ARCHITECTURAL DESIGN PUBLICATIONS LTD, LONDON, 1983
- ROGER H. CLARK AND MICHAEL PAUSE, PRECEDENTS IN ARCHITECTURE, VAN NOSTRAND REINHOLD COMPANY, NEW YORK, 1985
- ROGER W. HAINES, CONTROL SYSTEMS FOR HEATING, VENTILATING AND AIR CONDITIONING, VANNOSTRAND REINHOLD COMPANY, 1983.
- ROY MASON, XANADU, ACROPOLIS BOOKS LTD. 1983.
- RUSSELL L. ACKOFF, THE ART OF PROBLEM SOLVING, JOHN WILEY & SONS, 1978
- STEVENS ANDERSON, OPEN OFFICE SYSTEMS GAIN FLEXIBILITY, ARCHITECTURE, JUNE. 1988.
- TOM FORESTER, HIGH-TECH SOCIETY, THE MIT PRESS, 1987.
- TOM FORESTER, THE INFORMATION TECHNOLOGY REVOLUTION, THE MIT PRESS, CAMBRIDGE, MA, 1985

UNICOM SEMINARS' MAGAZINE, INTELLIGENT BUILDINGS, 7,8,9
DECEMBER, 1987.

WEST CHURCHMAN, THE SYSTEMS APPROACH AND ITS ENEMIES,
NEW YORK, BASIC BOOKS. 1979.

WILLIAM L.PULGRAM, RICHARD E.STONIS, DESIGNING THE
AUTOMATED OFFICE, WHITNEY LIBRARY OF DESIGN, 1984.

WILLIAM W.AIRD, THE RADICAL IMPACT OF TELECOMMUNICATIONS,
ARCHITECTURE, FEBRUARY. 1988.

W.ROSS ASHBY, AN INTRODUCTION TO CYBERNETICS, LONDON. CHAPMAN
& HALL, LTD. 1961.

W.ROSS ASHBY, DESIGN FOR A BRAIN, LONDON.CHAPMAN & HALL, LTD.
1980.

YVON GARDEN, ARCHITECTURAL DESIGN AND CAD, LONDON, NICHOLS
PUBLISHING COMPANY. 1986.