

Copyright Warning & Restrictions

The copyright law of the United States (Title 17, United States Code) governs the making of photocopies or other reproductions of copyrighted material.

Under certain conditions specified in the law, libraries and archives are authorized to furnish a photocopy or other reproduction. One of these specified conditions is that the photocopy or reproduction is not to be “used for any purpose other than private study, scholarship, or research.” If a user makes a request for, or later uses, a photocopy or reproduction for purposes in excess of “fair use” that user may be liable for copyright infringement,

This institution reserves the right to refuse to accept a copying order if, in its judgment, fulfillment of the order would involve violation of copyright law.

Please Note: The author retains the copyright while the New Jersey Institute of Technology reserves the right to distribute this thesis or dissertation

Printing note: If you do not wish to print this page, then select “Pages from: first page # to: last page #” on the print dialog screen

The Van Houten library has removed some of the personal information and all signatures from the approval page and biographical sketches of theses and dissertations in order to protect the identity of NJIT graduates and faculty.

ABSTRACT

Title of Thesis: Bead Design For Biodegradation of
2-chlorophenol Using Microorganisms
Entrapped in Alginate Gel

Fayaz Lakhwala: Master of Science in Chemical Engineering,
1988

Thesis directed by: Sam S. Sofer, Professor
Sponsored Chair in Biotechnology

The performance of immobilized cell reactors varies with a number of parameters, one of which is proper bead design. A mixed microbial population from a waste water treatment plant was immobilized in calcium alginate gel. The viability of these organisms was studied in a microassay reactor by varying parameters such as concentration of calcium chloride, concentration of sodium alginate, temperature of operation, biomass concentration within the

beads and concentration of a model compound (2-chlorophenol). The effect of storage on viability over a period of three months was also investigated. It was found possible to have access to active biomass by drying the beads and storing at 4°C.

In addition, polyvinyl alcohol gel and diatomaceous earth beads were also tried as supports for microbe immobilization.

Rates of removal of the substrate (2-chlorophenol) were followed in an air sparged semibatch reactor of volume 300 ml, at 37°C. It was found that 40 percent of the removal was by stripping and about 60 percent was due to biooxidation.

BEAD DESIGN FOR BIODEGRADATION OF 2-CHLOROPHENOL
USING MICROORGANISMS ENTRAPPED IN ALGINATE GEL

by
Fayaz Lakhwala
=

Thesis submitted to the Faculty of the Graduate School of
New Jersey Institute of Technology in partial fulfillment
the requirements for the degree of
Master of Science in Chemical Engineering
1988

Blank Page

VITA

Name: Lakhwala Fayaz Saifuddin

Permanent Address: 258, Highland Ave., Kearny, N.J. 07032.

Degree and Date to be conferred: M.S., 1988

Date of Birth:

Place of Birth:

Secondary education:

----- Collegiate institutions attended -----	Dates	Degree	Date of Degree
New Jersey Institute of Technology. Newark, N.J.	Sept 1986 to May 1988	M.Sc.	May 1988
Siddaganga Institute of Technology. Tumkur, India.	Sept 1981 to Dec 1985	B.E.	Jan 1986

Major: Chemical Engineering

Publications: Fayaz S. Lakhwala, Mayur P. Lodaya, Yang Kai
Chung, Gordon A. Lewandowski and Sam S. Sofer.
"Design of Toxic Waste Treatment Bioreactor:
Viability Studies of Microorganisms Entrapped in
Alginate Gel". Presented at International
Conference on Physiochemical and Biological
Detoxification of Hazardous Wastes, Atlantic
City, N.J. May 1988.

ACKNOWLEDGEMENTS

I wish to express my sincere gratitude to my supervising professor Sam S. Sofer, for his guidance, friendship and moral support throughout this research.

Special thanks are also due to Professor Gordon Lewandowski and Professor Richard Trattner for being members on my Masters Committee.

I am also grateful to State of New Jersey for funding through the Sponsored Chair in Biotechnology monies in initiating this project.

My sincere thanks are also to Hazardous Substance Management Research Center in providing funds for further and continued research on this project.

Appreciation is also expressed to all members of the Detox Group for their timely help and suggestions in conducting this project.

Finally I would like to thank Emilia Rus, Dewon Pak, Bill Guzy and Mary Camp for their help.

TABLE OF CONTENTS

Chapter	Page
I. INTRODUCTION	1
1.1 Immobilization and its Advantages	1
1.2 Mass Transfer Charecteristics	3
1.3 Requirements of Dissolved Oxygen	4
1.4 Activated Sludge and Biodegradation	6
II. LITERATURE SURVEY.....	8
III. OBJECTIVE	13
IV. MATERIALS AND EXPERIMENTAL METHODS	14
4.1 Microorganisms	14
4.2 Defined medium	14
4.3 Immobilization	15
4.3(i) Attachment on inert supports	15
4.3(ii) Entrapment in calcium alginate gel...	15
4.3(iii) Entrapment in polyvinyl alcohol gel..	16
4.4 Viability Studies in a Microassay Reactor.....	17
4.4(i) Viability in alginate beads	19
4.4(ii) Viability in polvinyl gel	19
4.5 Biodegradation of 2, chlorophenol in an Air Sparged Reactor	20
4.5(i) Wet alginate beads	20
4.5(ii) Free microorganisms	23
4.5(iii) Dry alginate beads	23
4.6 Controls.....	23
V. RESULTS AND DISCUSSIONS	24
5.1 Immobilization and Bead Stability	24
5.2 Effect of Temperature on Oxygen Uptake	25
5.3 Effect of Calcium chloride Concentration on Oxygen Uptake	27

5.4	Effect of Biomass Concentration on Oxygen Uptake	29
5.5	Effect of 2, chlorophenol Concentration on Oxygen Uptake	29
5.6	Effect of Sodium alginate Concentration on Oxygen Uptake	32
5.7	Effect of Storage on Oxygen Uptake	32
5.8	Physical Removal of 2, chlorophenol in an Air Sparged Reactor	35
5.9	Biological Removal of 2, chlorophenol in an Air Sparged Reactor	37
	5.9(i) Wet alginate beads.....	37
	5.9(ii) Free microorganisms	41
	5.9(iii) Dry alginate beads	41
VI.	CONCLUSIONS AND SUGGESTIONS	43
6.1	Conclusions	43
6.2	Suggestions	44
	APPENDIX A	47
	BIBLIOGRAPHY.....	49

LIST OF TABLES

Table		Page
I.	Effect of Sodium Alginate concentration on Bead Stability and Oxygen Uptake.....	34
II.	Effect of Storage Medium and Time on Rate of Oxygen Uptake.....	36

LIST OF FIGURES

Figure	Page
I. Experimental Setup of Microassay Reactor.....	18
II. Comparison of Microbial Respiration within Alginate and Polvinyl Gel.....	21
III. Experimental Setup of Air Sparged Reactor.....	22
IV. Effect of Temperature on Rate of Oxygen Uptake....	26
V. Effect of Calcium Chloride concentration on Rate of Oxygen Uptake.....	28
VI. Effect of Biomass concentration on Rate of Oxygen Uptake.....	30
VII. Effect of 2-Chlorophenol concentration on Rate of Oxygen Uptake.....	31
VIII. First Order Plot for Physical removal of 2-chlorophenol in Air Sparged Reactor.....	36
IX. Total removal of 2-Chlorophenol in an Air Sparged Reactor.....	38
X. First Order Plot for Total removal of 2-Chlorophenol in an Air Sparged Reactor.....	39
XI. First Order Plot for Total removal of 2-Chlorophenol in an Air Sparged Reactor at Different spiking concentrations.....	40
XII. Comparison between Free and Immobilized.....	42
XIII. Experimental Setup of a Recirculation Reactor....	45

CHAPTER I

INTRODUCTION

1.1 IMMOBILIZATION AND ITS ADVANTAGES

Application of immobilized bacterial cells for biodegradation has been a subject of intensive study in recent years. The technique of immobilization has a lot of advantages over the conventional free system in treatment of aqueous wastes. Washout of biomass is one of the most common problems encountered in biological treatment of toxic organic chemicals. Furthermore, long residence times are required so that the organisms can become acclimated and evolve a population that is compatible with the feed. Many of these conditions can be significantly improved using immobilized microorganisms. The system facilitates separation and has a greater degree of operational flexibility as continuous or semicontinuous processes become practical. Immobilized cells can be much more resistant to high concentrations of toxic chemicals (1). In addition, the cell density of immobilized cells can be much higher than that of the free cells, resulting in higher rates of biodegradation per unit volume of the reactor. Moreover, immobilized cells can also be dried and stored as a convenient source of reproducible biomass.

Numerous methods have been developed for immobilized biocatalyst preparation (1). There is no universal carrier nor immobilization method for all living cells, and each application should be separately tested and optimized. The support material should be able to withstand substrate, product and reaction conditions and it should be suitable for continuous or repeated use in the scale desired. Moreover, the method should be sufficiently gentle for the living cells. For example, fungal mycelium may simply be dried and grown in a pellet form to be used as a biocatalyst (2). Microbial cells may be flocculated or aggregated; they may be attached to a suitable carrier by adsorption or ionic bonding, or they may be entrapped in a polymer matrix. Among the most used adsorption carriers are activated charcoal, porous ceramics and porous silica supports. Suitable polymers for entrapment of cells include alginate, K-carageenan, polyacrylamide and polyvinyl alcohol.

Attachment on the surface of solid support offers an advantage because the support is stronger than the gel matrices. Diffusion of oxygen and substrate is no longer a major problem, as growth is on the surface. The disadvantages are that the microorganism cannot take shock loadings of toxic compounds, as they are not protected, and the problem of washout still remains under severe operating conditions of flow.

In the present study, calcium alginate and polyvinyl alcohol gel were investigated for entrapment of cells while diatomaceous earth and Celite biocatalyst carrier R-630 (both obtained from Manville filtration and minerals) were studied as carriers for attachment.

1.2 MASS TRANSFER CHARACTERISTICS

One of the many critical parameters which affects the kinetics of immobilized microbes is the diffusional or mass transfer effect. Cell entrapment in alginate is a rather simple and non-toxic method for immobilization, but the gel may create a diffusional barrier for both substrate and oxygen. The average pore size of this gel (natural polysaccharide) is estimated to be larger than that of polyvinyl alcohol and other polymeric gels. Calcium alginate gel is therefore used mainly as a carrier for the immobilization of whole cells. On the other hand, large pore size can cause problems by allowing the entrapped enzymes or cells to leak out. Polymeric gels have smaller pore size and can be used to overcome leakage of cells and enzymes, but they offer more resistance to diffusion of substrates. It is reported that calcium alginate gel provides little barrier to diffusion of neutral substrates up to a molecular weight of 5,000 [3].

In the case of microorganisms entrapped within a matrix, the mass transfer resistance around the beads may

reduce the effectiveness of microbial activity per unit volume by limiting the availability of substrates, resulting in lower specific substrate utilization. According to some studies [4], mass transfer resistance around the beads is closely related to system parameters used in the reactor, such as flow rate, bead size and bead composition, but the mass transfer within the beads is still limited by intraparticle diffusional resistance.

1.3 REQUIREMENTS OF DISSOLVED OXYGEN

In a system utilizing aerobic microorganisms for biodegradation of organic compounds, dissolved oxygen requirements are of immense importance. Biodegradation of chlorinated organic compounds such as 2,4-dichlorophenoxy acetic acid requires molecular oxygen as a cosubstrate for metabolism [5]. Aerobic microorganisms also utilize oxygen primarily as the terminal electron acceptor for aerobic respiration. In general, bacterial respiration does not appear to be affected above a critical dissolved oxygen concentration. The critical dissolved oxygen concentration has been defined as the concentration at which the respiration rate of cells is one half of the maximum rate observed at saturation levels. It is generally lower for dispersed cultures than for flocculant cultures [6]. Relatively little is known about the influence of dissolved oxygen on the microbial degradation of organic chemicals. In

one of the studies it was found that the half life of biodegradation of nitrilotriacetic acid in natural water samples increased from 1.3 to 5.8 days as the dissolved oxygen concentration decreased from saturation level to about 0.3mg/liter [7]. In the case of microorganisms entrapped in alginate gel, diffusion can become a rate limiting factor for oxygen uptake and may further increase half life of biodegradation. The degradative pathways involve a number of enzymes. If one of them is oxygenase, then the degradative rate should also depend on oxygen concentration.

A disadvantage of immobilization is the increased diffusional resistance of substrates and products through immobilization matrices. Due to the low solubility of oxygen in water and high local cell density, oxygen transfer is often the rate limiting factor in the performance of aerobic immobilized cell systems [8]. Methods that have been used to increase the availability of oxygen to immobilized cells include decreasing the particle size of the immobilization matrix and increasing the oxygen holding capacity of the medium. Increasing the oxygen holding capacity of the medium has been attempted by the addition of hydrogen peroxide and perfluoro chemicals [8,9].

1.4 ACTIVATED SLUDGE AND BIODEGRADATION

Biological treatment, and the activated sludge process specifically, are used widely for treatment of municipal and industrial wastes. The large variety of microorganisms present in the activated sludge reactor and their interaction may hold the key to the effective treatment and removal of chlorinated compounds. The diversity of the microbial flora serves as a good environment for developing cultures that can biodegrade synthetic organics in general and chlorinated organics specifically.

Chlorinated phenols are among the organic chemical pollutants that are most toxic, and hence, resistant to biodegradation. It has been reported that phenol is degraded with first order or Monod kinetics using free microorganisms [10], but substrate inhibition may take place with chlorinated phenols. For microorganisms entrapped in alginate gel, the rate constants may not be the same as those for free microbes, and factors other than microbial activity may be rate limiting. Research over the past has indicated that acclimated cultures capable of utilizing chlorinated organic substrates can be derived from activated sludge, and are effective over a wide range of substrate concentrations [11].

In general, biological treatment systems involve three competing removal mechanisms: adsorption, stripping and biodegradation [12]. The stripping rate is a direct function

of the thermodynamic equilibrium between the liquid and gas phases. Many of the organic priority pollutants are hydrophobic compounds with large activity coefficients. As a result, these compounds tend to volatilize from the aerated reactor if the vapor pressure is sufficiently high. Hence, aerobic biological treatment becomes a system of two competing removal mechanisms : biodegradation and stripping (neglecting adsorption). It is therefore necessary to investigate which is the primary removal mechanism, since stripping is not a desirable mechanism. Moreover, if the microorganisms are not acclimated to the compounds, then aeration may cause significant release of these substances into the atmosphere.

CHAPTER II

LITERATURE SURVEY

The ultimate fate of halogen containing organic chemicals in the ecosystem and in particular in the aquatic environment has been a focus of extensive research. There has been a growing interest in obtaining more precise descriptions of biodegradation rates of specific chemicals in waste water treatment systems to characterize decay rates in the environment. Most of the literature on biodegradation of chlorinated organic chemicals deals with use of free microorganisms.

Shamat and Maier [13] reported that activated sludge biomass could be used to develop microbial populations capable of completely metabolizing chlorinated organic compounds. They also studied the kinetic parameters of these microorganisms in order to assess their feasibility of removing chlorinated organic wastes by the activated sludge process.

Lewandowski et al. [14] studied the microbial response of mixed liquors from two different treatment plants to industrial organic chemicals. Although the mixed liquors came from very different systems, their responses to the industrial chemicals, as well as the initial and final

microbial populations, were very similar. It was also found that the primary removal mechanism for the compounds tested (phenol, 2-chlorophenol) was biodegradation, and removal by stripping and adsorption were negligible under the conditions of operation.

Westmeier and Rehm [15] studied the biodegradation of 4-chlorophenol by calcium alginate entrapped Alcaligenes sp.A7-2. When they compared the degradation rates of free and immobilized cells, they found that calcium alginate protects the cells against high concentrations of 4-chlorophenol and allows a more rapid degradation. No degradation products could be determined by HPLC detection after complete mineralization. They showed that high frequency feeding of small amounts of 4-chlorophenol was more favorable than low frequency feeding of larger amounts. They found that repeated use of immobilized microorganisms strongly increased the degradation rates, but starvation for about three days caused a rapid decrease in degradation.

Macaskie et al. [16], investigated the ability of polyacrylamide gel-immobilized cells of Citrobacter sp. to remove cadmium. Metal uptake was mediated by the activity of a cell bound phosphatase, induced during the pre-growth of cells. They reported that polyacrylamide gel, though suitable for laboratory scale experiments, would not be applicable to a large scale process due to the economic considerations and toxicity of the gel precursors, and also

due to limited mechanical strength of the gel.

Klein et al. [17] investigated the kinetics of phenol degradation by free and immobilized Candida tropicalis. In both cases, the reaction was zero order with respect to phenol concentration over the range tested (< 1 gm/l). Oxygen concentration was a major factor controlling degradation rate. An attempt was made to model this effect within the beads. Bead radius, number of cells per bead, specific activity of each cell, the bulk oxygen concentration and the oxygen diffusivity within the matrix were the important variables.

Shaler and Klecka [18], studied the effects of dissolved oxygen concentration on biodegradation of 2,4-dichlorophenoxyacetic acid. The relationship between specific growth rate and concentrations of both the organic substrate and dissolved oxygen was found to follow Monod kinetics. They reported that dissolved oxygen concentrations below 1 mg/liter may be rate limiting for the biodegradation of chlorinated aromatic compounds such as 2,4-dichlorophenoxyacetic acid, which have a requirement for molecular oxygen as a cosubstrate for metabolism.

Tanaka et al. [19], studied diffusion characteristics of several substrates of varying molecular sizes into and from calcium alginate gel beads. It was found that diffusion of high molecular weight substrates was limited more strongly by the increase of calcium alginate concentration

in the gel beads than by the increase in calcium chloride concentration used in curing the beads. Substrates having molecular weight less than 20,000 were easily taken into the gel.

In another study Gosmann and Rehm [20] investigated oxygen uptake of three different microorganisms, Pseudomonas putida, Saccharomyces cerevisiae and Aspergillus niger, all immobilized in calcium alginate gel. The oxygen uptake was compared with respiration of free cells. It was shown that the specific oxygen uptake of free microorganisms decreased at lower cell concentration. On the other hand, by increasing cell concentration in the gel, oxygen was consumed faster than it could diffuse into the beads. At this point, the cells had to compete for oxygen, and diffusion became the limiting factor for oxygen uptake.

Lurker et al. [21], in their investigation for atmospheric release of chlorinated organic compounds from the activated sludge process, found that over half of the chlorinated hydrocarbons emitted were released by air stripping from the aeration basins.

A laboratory scale activated sludge unit, which allowed a comparison of biological and physical removal of hydrocarbons from acclimated biomass, was developed by Tischler et al. [22]. Studies of two industrial petrochemical wastewater samples showed that biological removal of the hydrocarbon was far more significant than

removal by air stripping, which was only 0.22 and 0.31% of the total organic carbon of the waste.

In another study, Lewandowski and Armenante [23] reported that physical removal of 2-chlorophenol is a first order process, with a rate constant of $5.5 \times 10^{-3} \text{ hr}^{-1}$. This value could also be predicted from thermodynamic consideration by assuming a 30% saturation of air leaving the reactor.

CHAPTER III

OBJECTIVES

The primary objective of this research has been to determine the feasibility of using immobilized microorganisms to treat hazardous and toxic wastes in aqueous solutions.

The first step has been the investigation of the performance of different immobilizing matrices, in order to have a system which is stable and viable. From among those investigated, one has been selected for detailed studies. In the next step, factors affecting the stability of the matrix, and the viability of microorganisms attached or entrapped are studied so effective beads with viable populations are obtained.

With a properly designed matrix, the resulting beads are then used in a batch reactor to treat a model toxin (2-chlorophenol), and the biokinetic rate constants for its biodegradation are obtained.

CHAPTER IV

MATERIALS AND EXPERIMENTAL METHODS

4.1 MICROORGANISMS

Activated sludge (mixed microbial population) from the Livingston (N.J.) waste water treatment plant was used in the present study. The microorganisms were acclimated at room temperature with phenol (100 ppm) and 2-chlorophenol (10 ppm) successively over a period of ten days, (approximately 10 spikes) with continuous aeration. The culture was then centrifuged (International portable refrigerated centrifuge, model PR-2) at 3000 rpm and 15°C to obtain concentrated pellets, which were then stored at 4°C.

4.2 DEFINED NUTRIENT MEDIUM

The composition of defined nutrient medium used was as follows [23].

Magnesium sulfate	100 mg
Manganese sulfate	10 mg
Ferric chloride	0.5 mg
Potassium phosphate (pH 7.2)	30 ml (0.1M)
Water	100 ml

The above solution was then diluted to 1000 ml by adding distilled water.

Fixed nitrogen was excluded from the defined medium in order to prevent biological growth within the beads.

4.3 IMMOBILIZATION

(i) Attachment on inert supports

Diatomaceous earth beads and Celite biocatalyst carrier R-635, both obtained from Manville Filtration and Minerals (approx 1/16" to 1/8" dia.) were used as inert supports. These are silica based porous spheres and are recommended for microbe immobilization. A glass tube (1" dia and 9" length) was used as a packed bed reactor. Forty grams of beads were packed and an ammonium-glucose solution was introduced at a rate of 20 ml/min. After one hour the medium was inoculated with bacteria from the sludge. The medium was aerated in an external reservoir and recirculated at 37°C. In both cases no attachment or growth was observed after a period of five days. Changes in flow rate and nutrient medium did not result in any significant attachment.

(ii) Entrapment in Calcium alginate gel

Distilled water and concentrated pellets (45 mg dry biomass/gm of pellet) were taken in a ratio of 5:2 by weight in a blender. Sodium alginate (0.75% w/w) was then added slowly to the mixture with continuous stirring to obtain a homogeneous cell suspension. With the help of a syringe pump

(Sage Instruments, Model 351) the homogeneous cell suspension was then extruded as discrete droplets in a slowly stirred solution of 0.1 M calcium chloride. On contact with calcium chloride, the droplets hardened to form beads about 3-3.5 mm in dia. The beads were then cured in calcium chloride for 24 hours at 4°C before use.

(iii) Entrapment in Polyvinyl alcohol gel

The gel was made by dissolving polyvinyl alcohol in distilled water at 70-80°C (10% gel w/w). The gel was then autoclaved at 120°C (New Brunswick Scientific Co., Model AE 15-10). Sterilized gel and concentrated pellets were taken in a ratio of 5:2 and mixed thoroughly to obtain a homogeneous cell suspension. Using a syringe pump, the cell suspension was then extruded as discrete droplets in a cold and saturated solution of boric acid. The beads (about 3-3.5 mm in dia.) were cured in boric acid for two days at 4°C and then washed thoroughly in distilled water.

Unlike alginate beads, these beads did not stay separate but formed clusters on slight agitation. This is probably because the reaction between boric acid and the gel is not spontaneous as in the case of calcium chloride and sodium alginate.

Further investigation on bead design was done on alginate and polyvinyl alcohol beads, as preliminary investigations indicated their superiority for microbial

immobilization out of the four methods investigated.

4.4 VIABILITY STUDIES IN A MICROASSAY REACTOR

Viability studies of free and entrapped microorganisms were done in a microassay bioreactor, the experimental setup of which is shown in Figure (1). Viability here is defined as the ability of microorganisms to consume dissolved oxygen from the medium for endogenous respiration. The microassay reactor consists of a 1.9 ml water jacketed reaction vessel with a small magnetic stirring bar. Concentration of dissolved oxygen was monitored using a Clarke-type dissolved oxygen probe. Water at required temperature was circulated in the jacket through a water bath (Haake, TYP F-4391). The reactor was mounted on a stirrer plate, and the magnetic bar maintained uniform oxygen concentration. The oxygen probe was connected through an amplifier to a chart recorder assembly (Schlumberger, Model EU-205-11) which recorded changes in dissolved oxygen concentration [24].

Before the start of each run, the reactor was sterilized in an autoclave at 120°C and then washed successively with methanol and distilled water. It was then rinsed several times with sterile defined medium. Sterile defined medium (1.6 ml) was then added to the reactor, and saturated with oxygen by bubbling air through it. The saturation concentration of oxygen from air in water at 37°C

Fig. 1 EXPERIMENTAL SETUP OF MICROASSAY REACTOR

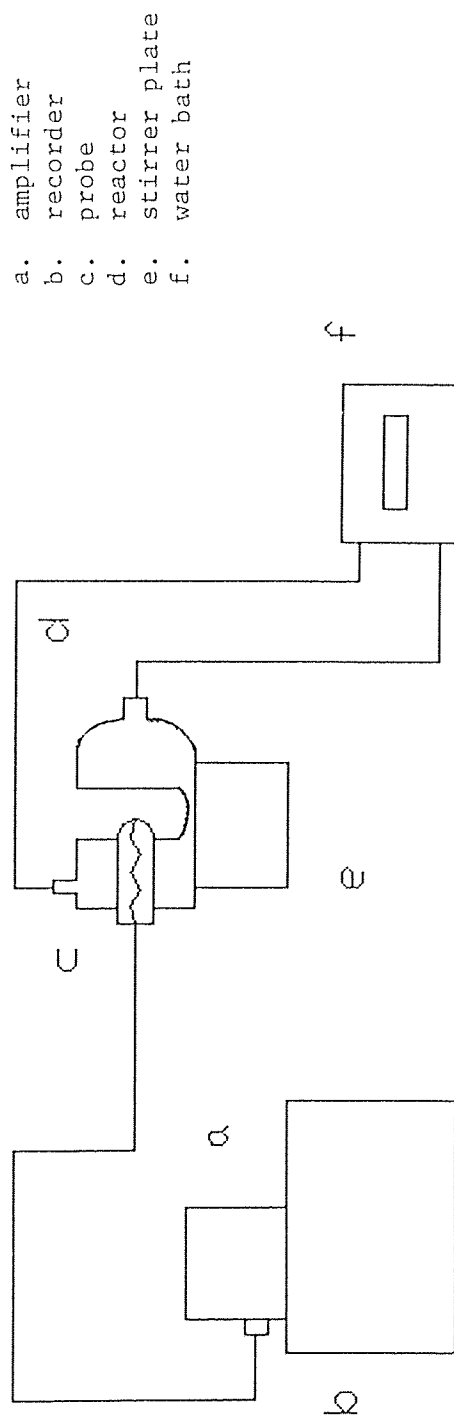

was estimated to be 200 nmoles/ml. After saturating with oxygen, 5 beads weighing a total of 0.05 gm (\pm 3.0 percent) were shocked at 42°C for 2-3 minutes in water and then put into the reactor. The shock treatment was carried out to revive the microorganisms from their dormant state, since they were stored at 4°C. The reactor was then sealed from the top, and concentration of dissolved oxygen was monitored on the strip chart recorder. Sufficient mixing was allowed to overcome any mass transfer resistance.

(i) Viability in alginate beads

Viability of microorganisms within alginate beads was studied by varying temperature, biomass concentration, concentration of calcium chloride, concentration of sodium alginate and concentration of 2-chlorophenol. Beads were also dried and stored at 4°C. Their activity was assayed over a period of three months and compared with beads stored in calcium chloride and buffer (Tris pH 7.4). The above parameters were all studied in the microassay reactor.

(ii) Viability in polyvinyl alcohol gel

Viability of microorganisms entrapped in 10% polyvinyl alcohol gel was studied and compared with that of alginate entrapped microorganisms. The procedure adopted for assay was identical to that followed for alginate beads using the microassay reactor. Activity of both dry and wet polyvinyl

alcohol beads was investigated.

Figure (2) shows the comparison of microbial respiration when free and immobilized in both alginate and polyvinyl alcohol gel.

4.5 BIODEGRADATION OF 2-CHLOROPHENOL IN AN AIR SPARGED REACTOR

(i) Wet alginate beads

The scale-up from microassay reactor to air sparged reactor was 600 times (0.05 g to 30 g). The experimental setup of the reactor is shown in Figure (3). The reactor is 2.5" in diameter and 8" in length. The total reaction volume is 300 ml, with 30 gm beads/ 300 ml of reaction volume. The reactor was immersed in a constant temperature water bath where temperature was maintained at 37°C. Filtered air was sparged into the reactor at the rate of 0.5 liters/min. Samples were taken periodically and analyzed on the gas chromatograph (Varian GC 3300) for concentration of 2-chlorophenol. The activity of beads was also tested periodically by running them on the microassay reactor. A starting concentration of 50 ppm 2-chlorophenol was used. After it had dropped to below 5 ppm, it was again spiked with 50 ppm, and so on. Similar runs were done with spiking concentrations of 75 ppm and 100 ppm.

Fig.2 Comparison of Microbial Respiration
within Alginate and Polyvinyl Alcohol Gel

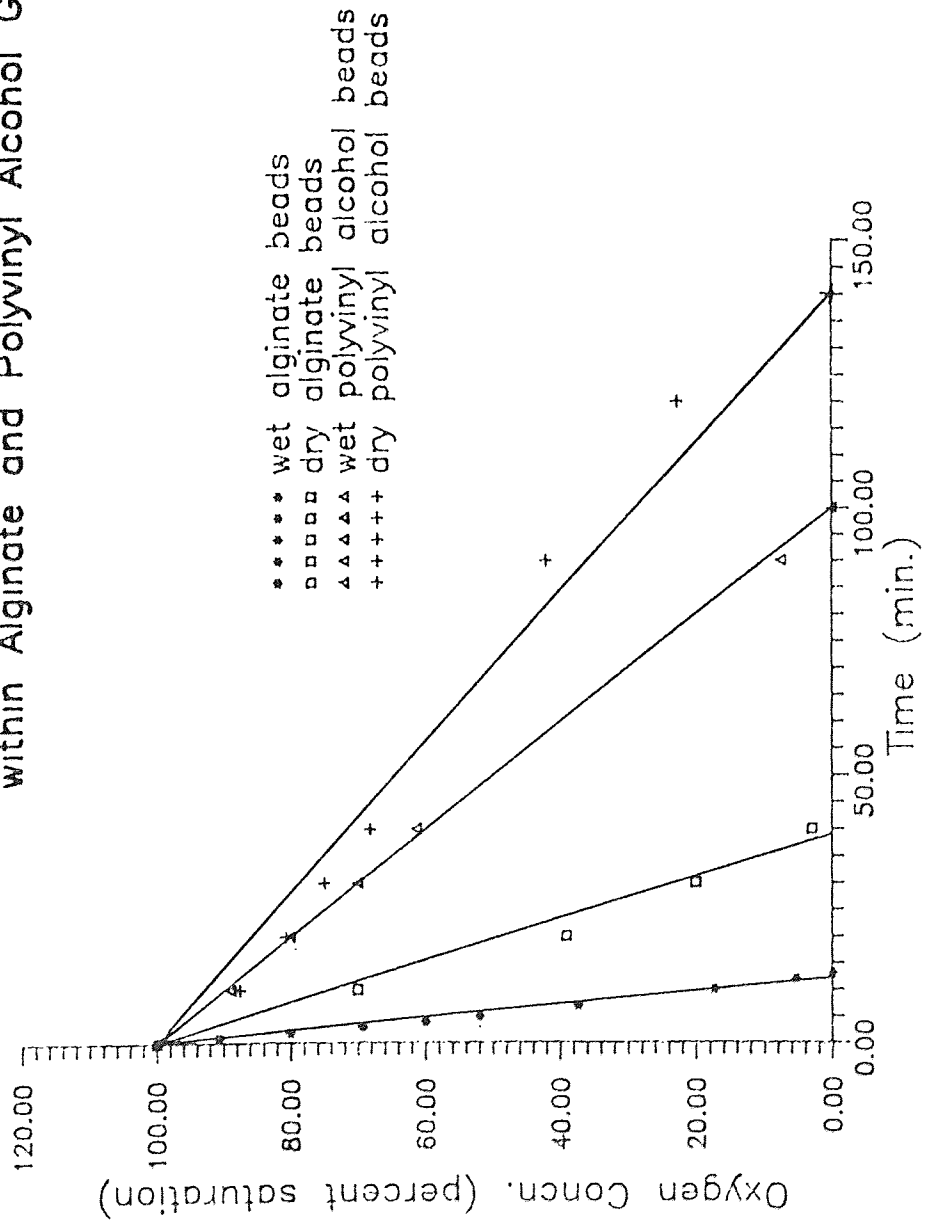

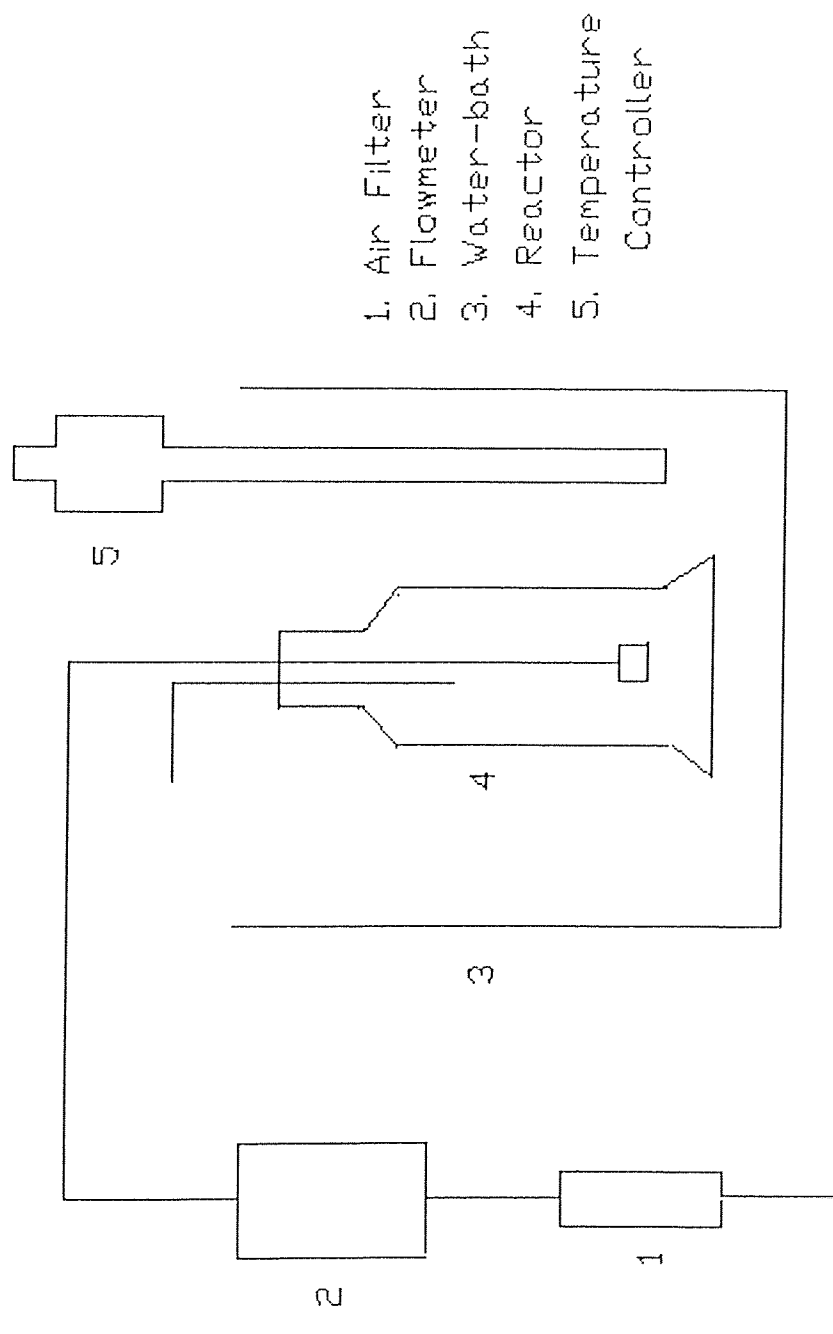

FIG. 3 AIR-SPARGED REACTOR

(ii) Free microorganisms

In a similar setup, 14 gm bacterial pellets (equivalent to 30 gm wet beads), of a concentration of 53 mg dry biomass per gm of pellets, were spiked with 50 ppm 2-chlorophenol. This experiment was done to compare the performance of free microbes over immobilized.

(iii) Dry alginate beads

The performance of dry beads in removing 2-chlorophenol was also compared with that of wet beads. Wet beads (60 gm) from the same pellets were taken, of which 30 gm were dried and stored at 4°C. After three days the two sets of beads were spiked with 50 ppm 2-chlorophenol. Rate of removal of 2-chlorophenol was observed in both cases, under identical conditions of temperature and air flow.

4.6 CONTROLS

Control runs were done under identical conditions of temperature and air flow (without biomass), to account for removal of 2-chlorophenol by physical processes, mainly due to stripping.

Alginate beads without any biomass were stirred in a solution of 50 ppm 2-chlorophenol to account for absorption by alginate gel. No absorption was seen over a period of 24 hours.

CHAPTER V

RESULTS AND DISCUSSION

5.1 IMMOBILIZATION AND BEAD STABILITY

Four different supports were investigated for microbe immobilization, of which only two gave positive results.

Diatomaceous earth beads and Celite carrier R-635, which were used for microbe immobilization by attachment on surface did not give positive results. No attachment was observed even after five days of continuous supply of nutrient media. Variations in flow rate of media and nutrient composition of the media were also done to induce attachment. It was found that these two materials were unsuitable for immobilization of a mixed population of bacteria, probably due to their small pore size.

Calcium alginate gel and polyvinyl alcohol gel, which were used as matrices for microbe immobilization by entrapment, gave good results. Out of the two, only calcium alginate gel seemed practical on a large scale. Polyvinyl alcohol gel was found unsuitable due to the following reasons:

(i) the beads could not be used at a temperature of 37°C which was found suitable for the microorganisms, since the gel matrix softened and dissolved at temperatures above 35°C,

(ii) the buffered medium was found unsuitable for the matrix, as the phosphate ions seemed to destroy the gel,

(iii) even on slight agitation the beads formed a cluster, and separate integral beads could not be obtained, and

(iv) the method of immobilization was not practical if beads were to be made on a large scale.

The only point in favor of polyvinyl alcohol gel was the bead stability. If used at lower temperatures (below 28°C) and in a medium not containing phosphate ions, the beads showed better stability.

Calcium alginate gel, on other hand, was stable at higher temperatures. Moreover, the method of immobilization is very easy and practical and gives well defined integral beads.

5.2 EFFECT OF TEMPERATURE ON OXYGEN UPTAKE

Temperature has a dual effect on the rate of oxygen uptake. First, it affects the activity of microorganisms; and second, it affects the solubility of oxygen. In the range of temperatures studied (30 - 45°C), the solubility of oxygen changes from 216.7 nmoles/ml to 183.3 nmoles/ml. Figure (4) shows rates of oxygen consumption as a function of temperature. A temperature of 37°C is found to be optimal with respect to rate of oxygen uptake. At temperatures lower

Fig.4 Effect of temperature on oxygen uptake.

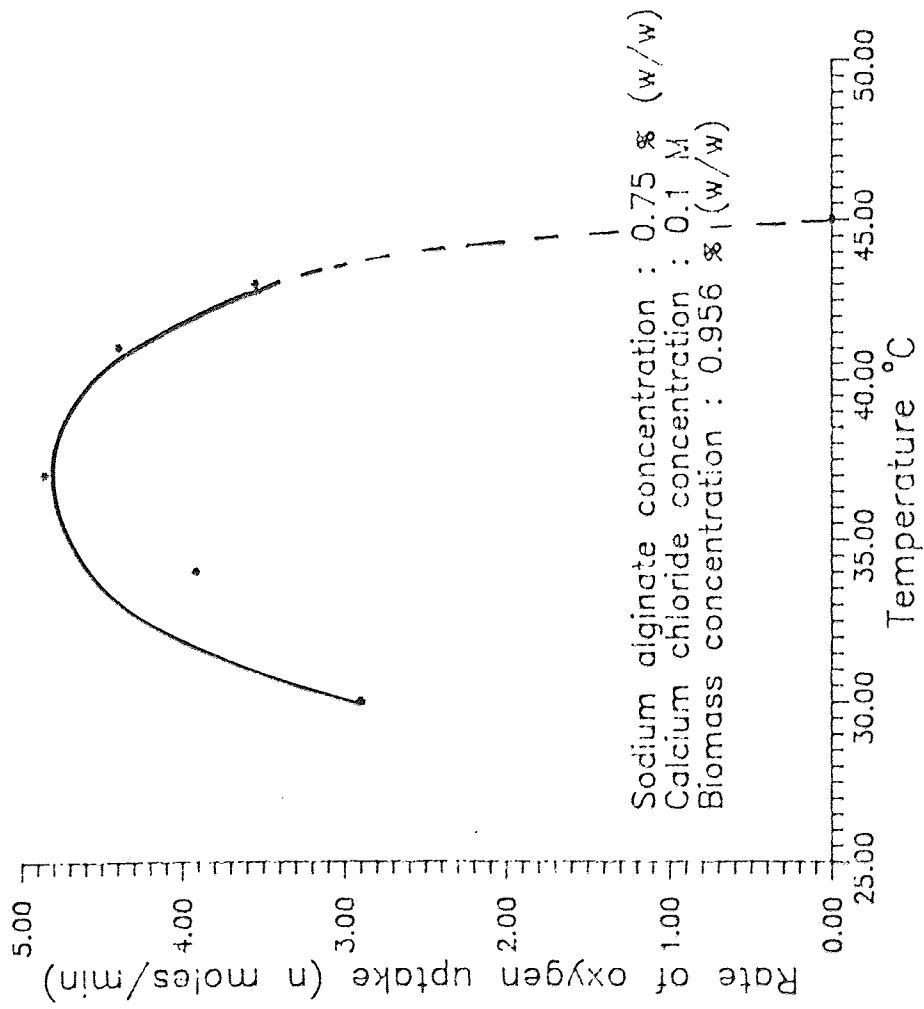

than 37°C, the rates are lower (although the saturation concentration of oxygen from air is higher at lower temperatures). At temperatures above 37°C, the rates drop again, probably due to thermal inactivation. At 45°C there was no observable oxygen consumption.

At a temperature of 37°C, the rate was almost twice as that at 30°C. Although biological reactions are not usually exposed to temperatures above room temperature, in some cases heating may prove advantageous.

Moreover, within the temperature range studied, the bead structure (alginate gel) was found to be stable unlike polyvinyl alcohol gel.

5.3 EFFECT OF CALCIUM CHLORIDE CONCENTRATION ON OXYGEN UPTAKE

The effect of calcium chloride concentration on oxygen uptake was studied with beads cured in 0.1, 0.2, 0.3, 0.5 and 1.0 M calcium chloride solution. Figure (5) shows the results, indicating that oxygen uptake rate when 1.0 M calcium chloride solution is used to cure the beads is about 70 percent of that when 0.1 M calcium chloride solution is used. Bead stability is unaffected by concentration of calcium chloride, and as a result most of the experiments in the present study were conducted with beads cured in a calcium chloride concentration of 0.2 M.

Fig.5 Effect of calcium chloride on oxygen uptake.

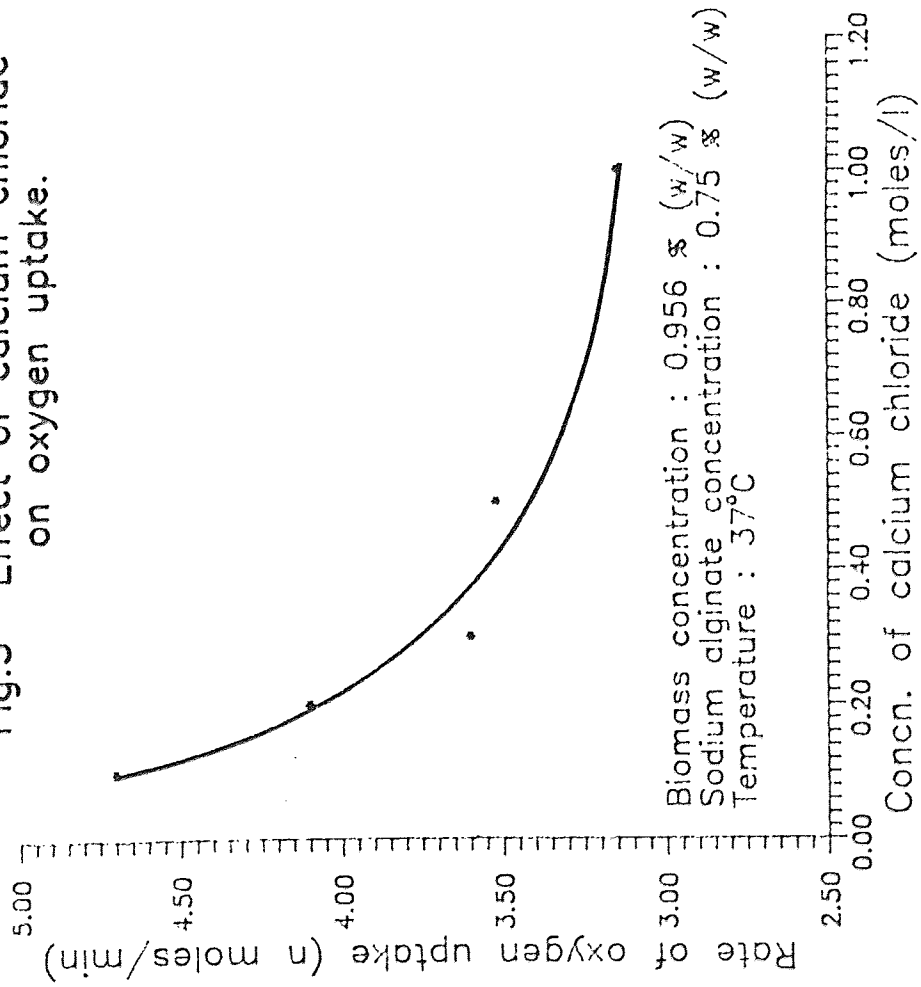

5.4 EFFECT OF BIOMASS CONCENTRATION ON OXYGEN UPTAKE

This study was performed in order to find the optimum biomass concentration in the alginate beads. The biomass concentration within the beads was changed by varying the ratio of water to bacterial pellets (see Methods section). The range of concentration studied was 5 to 40 mg biomass /gm of mixture.

Figure (6) shows changes in rates of oxygen consumption as a function of biomass concentration in the mixture. It is seen that the rates increase rapidly at lower concentration but at higher concentrations the curve levels off. In the present study, a concentration of 25 mg biomass/ gm of mixture was found to be optimal with respect to oxygen consumption and was used in most of the experiments.

5.5 EFFECT OF 2-CHLOROPHENOL CONCENTRATION ON OXYGEN UPTAKE

Figure (7) shows initial rates of oxygen consumption of acclimated microbes as a function of 2-chlorophenol concentration (ppm). The curve clearly shows an inhibitory effect at higher concentrations. At a concentration of about 13 ppm the maximum oxygen uptake rate was obtained. With further increase in 2-chlorophenol concentration, the oxygen uptake rate gradually fell, until at about 60 ppm the rate was almost the same as the endogenous rate.

Fig.6 Effect of biomass concentration on oxygen uptake

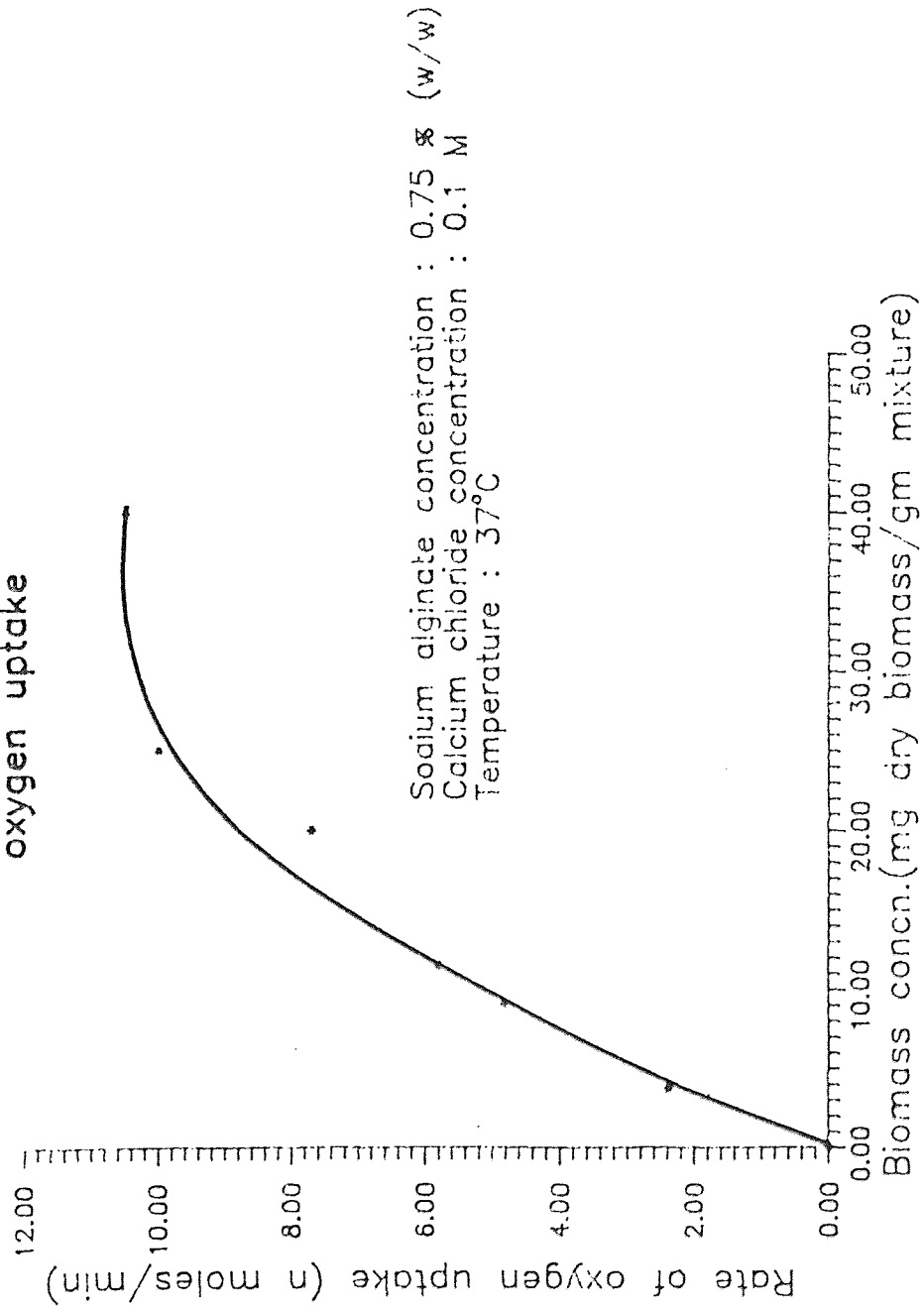
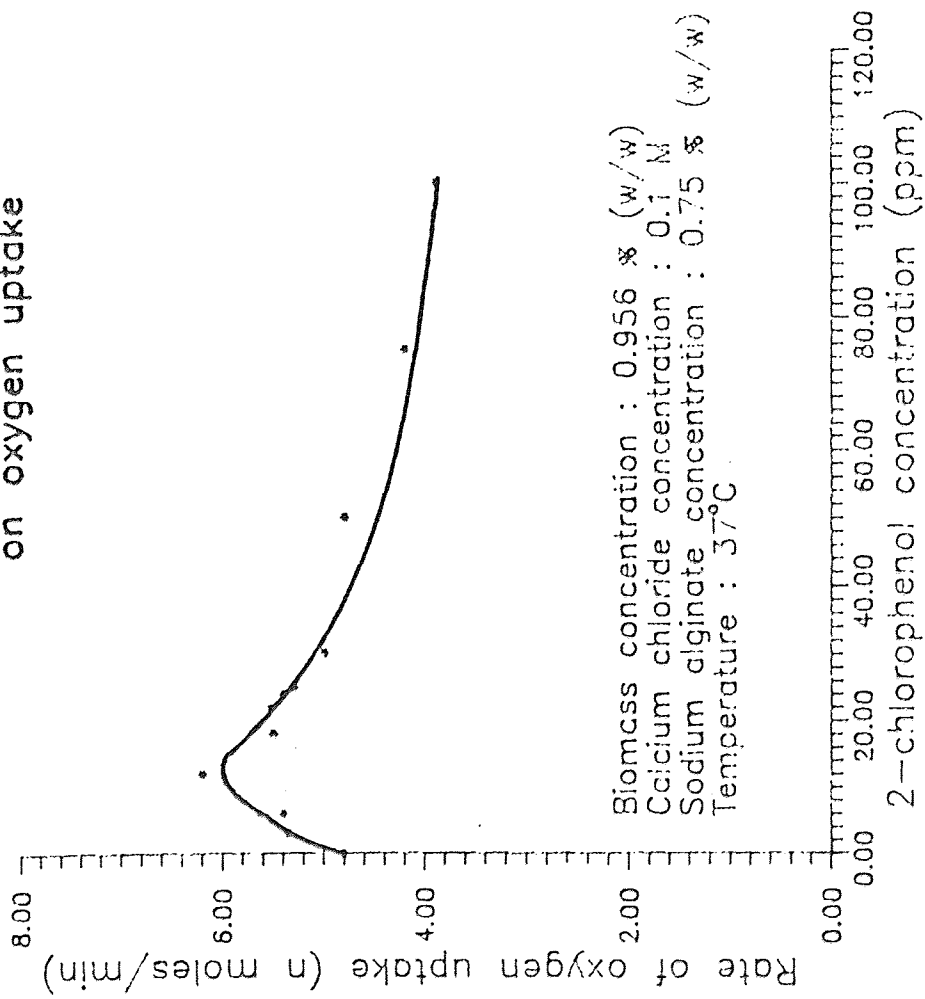

Fig.7 Effect of 2-chlorophenol concentration on oxygen uptake



Higher concentrations of 2-chlorophenol were spiked until it was found that a concentration of 5000 ppm inhibits the activity of microorganisms immediately. Similar runs with the same (acclimated) free bacteria showed immediate inhibition at a concentration of 750 ppm.

5.6 EFFECT OF SODIUM ALGINATE CONCENTRATION ON OXYGEN UPTAKE AND BEAD STABILITY

The concentration of sodium alginate is constrained at the lower end by the inability to produce an integral bead below 0.75 percent (w/w), and at the upper end by the difficulty of extruding beads above 1.5 percent (w/w).

As seen from Table (1), the oxygen uptake rate decreases with an increase in sodium alginate concentration. On the other hand, bead stability could be increased from 8 hours under high speed stirring for 0.75 percent alginate to 71 hours for 1.5 percent alginate. Hence the overall consumption of oxygen was high in the case of 1.5 percent alginate gel.

5.7 EFFECT OF STORAGE ON OXYGEN UPTAKE

This study was undertaken to find out the changes in the activity of microorganisms when stored in different media. The effect of storage was studied over a period of

Table 1: EFFECT OF SODIUM ALGINATE CONCENTRATION
ON BEAD STABILITY AND OXYGEN UPTAKE

Biomass concentration	0.956 % (w/w)
Calcium chloride concentration	0.1 moles/l
Temperature	37C.

<u>Sodium Alginate concentration % (w/w)</u>	<u>Rate of Oxygen Uptake (n moles/min)</u>	<u>Bead Stability (hours)</u>	<u>Total Oxygen Uptake (n moles)</u>
0.75	7.50	8.00	3600
1.00	5.70	24.00	8352
1.25	6.50	36.00	14,256
1.50	6.00	71.00	20,022

three months. Three batches of the same beads were taken, with one batch stored in 0.1M calcium chloride solution, another stored in buffer (pH 7.2) and the third batch dried. All the beads were stored at 4°C.

There was no appreciable change in activity over a period of ninety days in any given medium. However, there was a difference in activity from medium to medium. The average rates reported in Table (2) show that the activity is comparable in the case of calcium chloride solution and buffer, but is much lower for the dry beads reconstituted in defined medium.

5.8 PHYSICAL REMOVAL OF 2-CHLOROPHENOL IN AN AIR SPARGED REACTOR

Initial control runs on physical removal (stripping) showed that 2-chlorophenol was removed by first order kinetics with a "k" value of 0.085 hr^{-1} , at 37°C and an air flow rate of 0.5 liter/min. Figure (8) shows a typical first order plot for removal of 50 ppm 2-chlorophenol by stripping. This value of "k" compared with that obtained from thermodynamic consideration at 38.5 % saturation of the air bubbles leaving the reactor (Appendix A).

Runs on adsorption of 2-chlorophenol by alginate gel showed that alginate gel does not adsorb any 2-chlorophenol.

Table 2: EFFECT OF STORAGE MEDIUM AND TIME
ON RATE OF OXYGEN UPTAKE

<u>Time</u> <u>(days)</u>	<u>RATE OF OXYGEN UPTAKE</u> <u>(n moles/min)</u>		
	<u>Beads in</u> <u>0.1M CaCl</u>	<u>Beads in</u> <u>Buffer pH 7.2</u>	<u>Dry Beads</u>
1	5.82	-	-
2	-	6.21	-
15	8.85	6.60	2.42
25	7.35	8.72	2.89
40	6.17	6.08	2.33
60	6.54	6.45	1.73
90	8.72	4.00	2.22

Fig.8 First order plot for physical removal of 2-chlorophenol in air sparged reactor at 37°C and air flow of 0.5 l/min

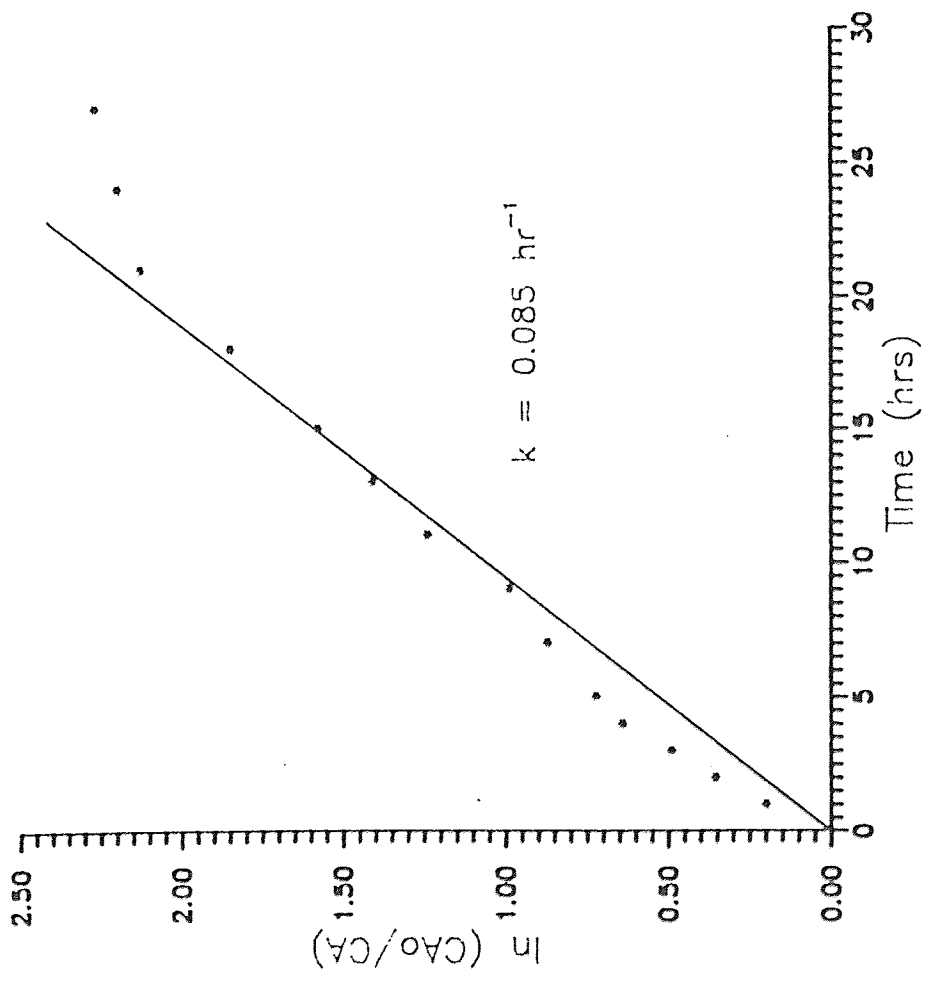

5.9 BIOLOGICAL REMOVAL OF 2-CHLOROPHENOL IN AN AIR SPARGED REACTOR

(i) Wet alginate beads

Total removal of 2-chlorophenol (physical and biological) was also found to follow first order kinetics. Figure (9) shows total removal of 2-chlorophenol from an initial concentration of 50 ppm 2-chlorophenol, using immobilized microorganisms. The overall "k" value was found to be 0.278 hr^{-1} . Figure (10) shows a typical first order plot for total removal of 2-chlorophenol. Comparing the "k" values of physical removal and total removal (at 50 ppm spiking concentration) shows that the primary removal mechanism is biodegradation, accounting for almost 60% of the total removal. The remaining 40% was removed by stripping.

By increasing the spiking concentration to 75 ppm and 100 ppm, it is observed that the "k" value decreases. As can be seen in Figure (11), the "k" value drops from 0.278 hr^{-1} to 0.14 hr^{-1} to 0.12 hr^{-1} as the spiking concentration increases from 50 ppm to 75 ppm to 100 ppm.

Although the overall rate is apparent first order, the removal by biodegradation may not essentially be a first order reaction.

Fig.9 Removal of 2-chlorophenol in air sparged reactor at 37°C and air flow of 0.5 l/min

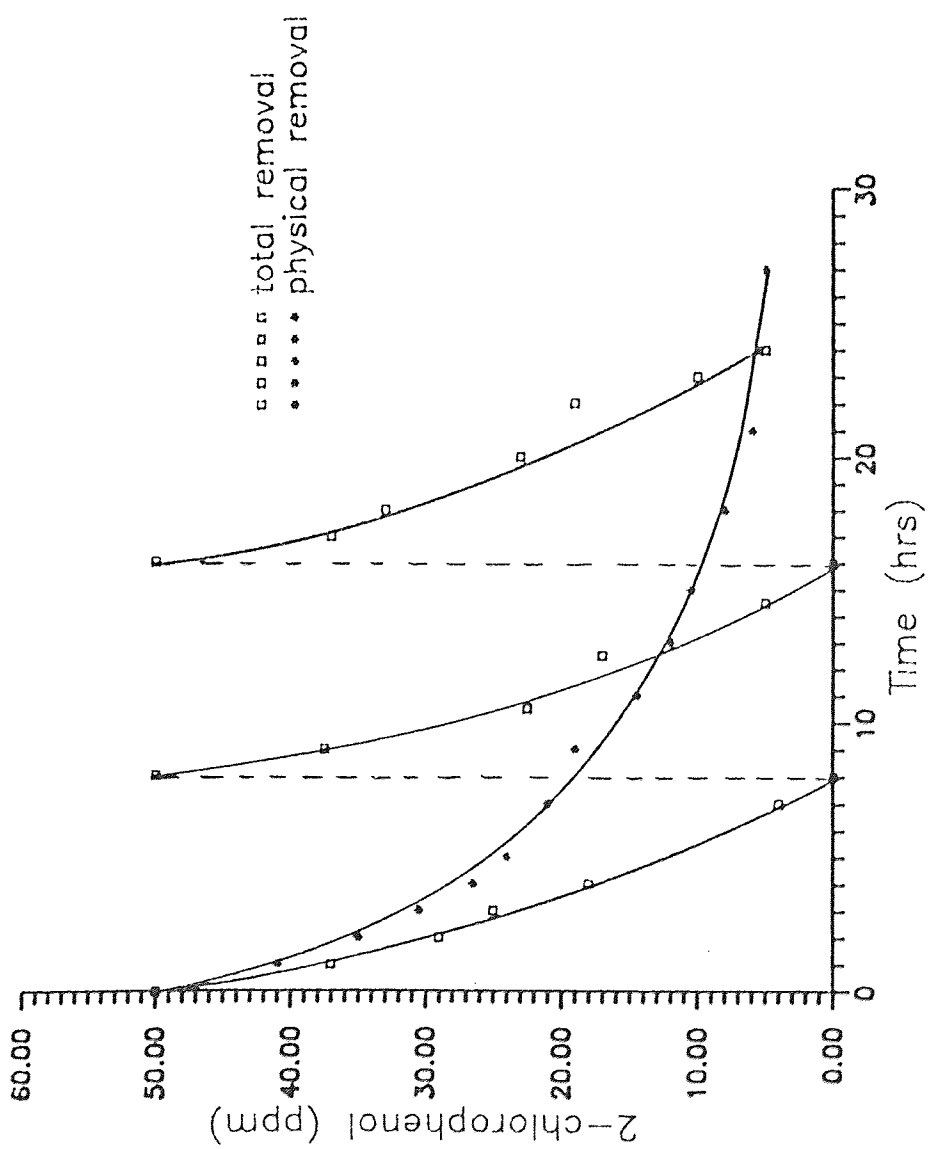

Fig.10 First order plot for total removal of 2-chlorophenol in air sparged reactor at 37°C and air flow of 0.5 l/min

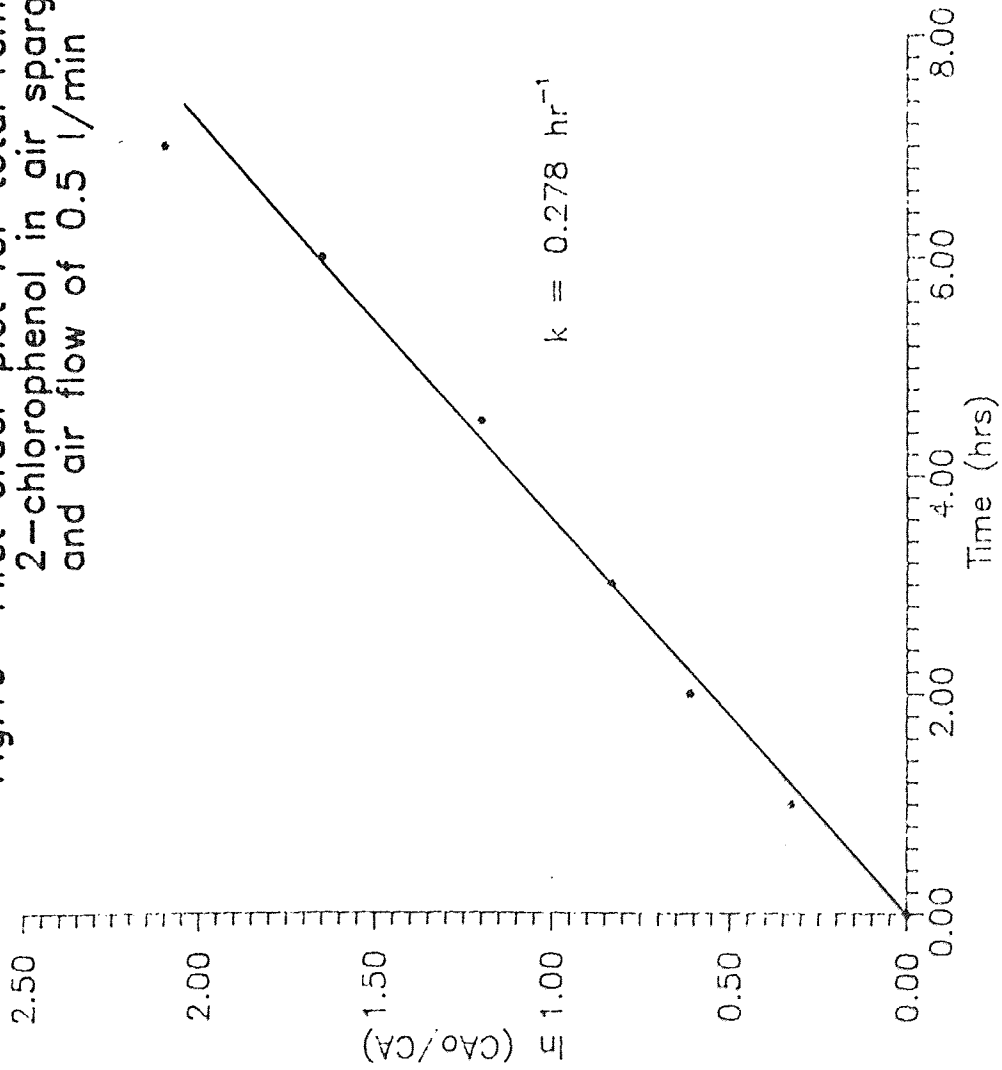
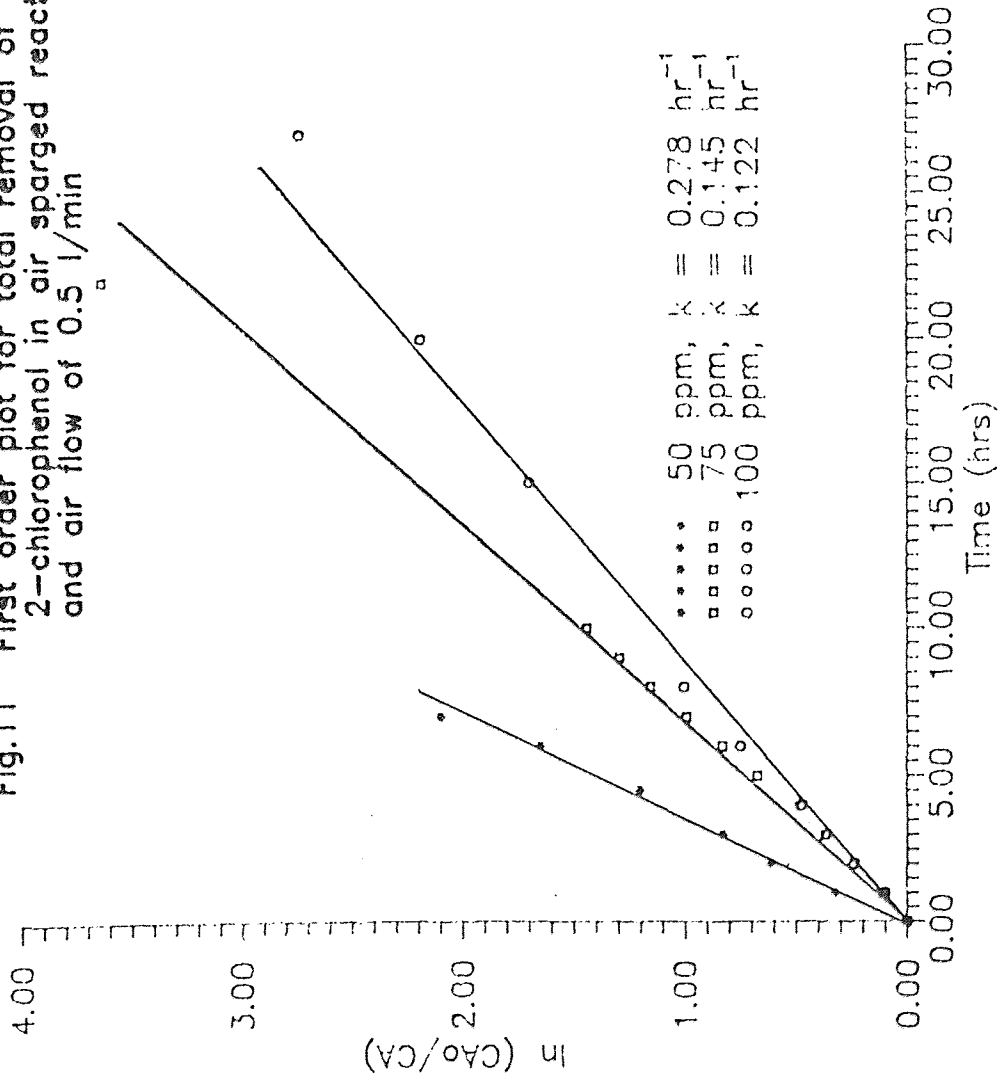

Fig.11 First order plot for total removal of 2-chlorophenol in air sparged reactor at 37°C and air flow of 0.5 l/min



(ii) Free microorganisms

The ability of immobilized microorganisms to withstand higher concentrations of 2-chlorophenol than the free microorganisms was also demonstrated. As can be seen in Figure (12), when exposed to 50 ppm 2-chlorophenol, the free microorganisms were unable to utilize 2-chlorophenol. On the other hand, with immobilized microorganisms the concentration of 2-chlorophenol was reduced to less than 5 ppm within 8 hours.

(iii) Dry alginate beads

From the initial experiments on microassay reactor, we knew that immobilized dry microorganisms can be reconstituted to have a viable population with about 30 % less activity. Biodegradation runs with dry beads showed that these microorganisms were unable to utilize 2-chlorophenol and the toxin was removed by a trend which closely followed stripping. The beads were reconstituted and the microassay test done during the run showed the presence of viable population inside the beads.

One of the reasons may be that upon drying the gel structure may change extensively hence preventing the diffusion of 2-chlorophenol.

Fig.12 Removal of 2-chlorophenol : A comparison of physical removal with biodegradation using free and immobilized microorganisms

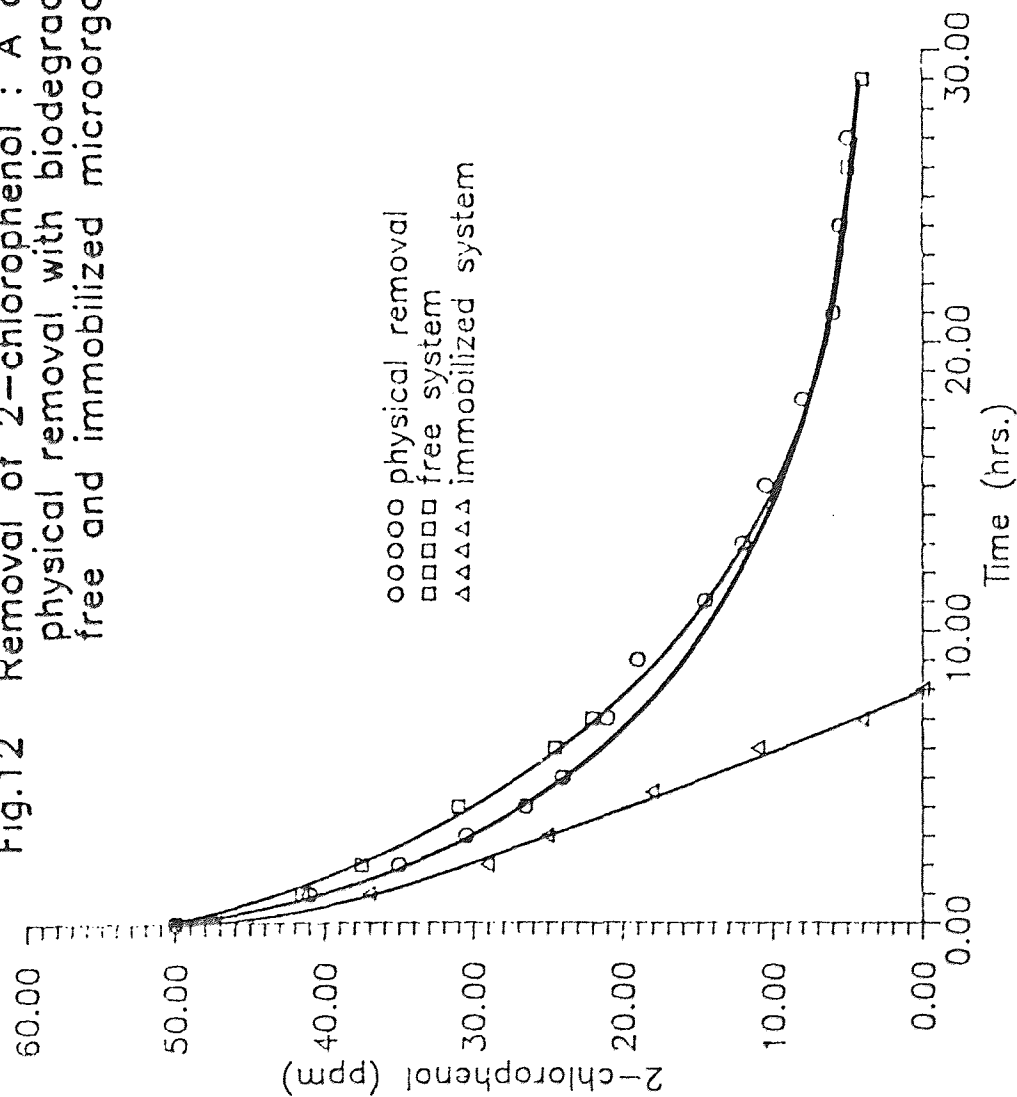

CHAPTER VI

CONCLUSIONS AND SUGGESTIONS

6.1 CONCLUSIONS

Preliminary studies have shown that microorganisms immobilized in calcium alginate gel can be effectively used for biodegradation of a model toxin at much higher initial concentrations, as with the use of "free" microorganisms. A study with acclimated free microorganisms showed that a concentration of 750 ppm 2-chlorophenol was fatal for the microorganisms. However, immobilized microbes could withstand a concentration of 5000 ppm 2-chlorophenol.

In the range of biomass concentrations studied, the optimum oxygen consumption rate was observed at a concentration of 25 mg dry biomass/gm of immobilizing mixture. Increasing the alginate concentration had a more pronounced effect on bead stability than did an increase in calcium chloride concentration.

The beads could be dried and stored for a long period to provide a reservoir of preacclimated active biomass, although 60% activity was lost on drying

Immobilized microorganisms degraded 50 ppm 2-chlorophenol in 8 hrs unlike the free microorganisms which

could not mineralize the same concentration.

Immobilized cell bioreactors should be applicable to the biodegradation of other compounds. Many xenobiotics have been found susceptible to biodegradation. It should be possible to customize bioreactors which degrade a specific chemical or a mixture of chemicals by the use of preacclimated bacteria immobilized in a suitable matrix.

6.2 SUGGESTIONS

In the present work, preliminary experiments in a batch reactor were conducted to assess the feasibility of immobilized mixed microbial population to biodegrade a model toxic compound (2-chlorophenol).

Further studies on the kinetic behavior of calcium alginate immobilized microbial cells should be conducted in a batch recirculation flow reactor as shown in Figure (13). The batch recirculation flow reactor is an effective tool to study both kinetic and process parameters. The system consists of a packed bed reactor with an externally aerated reservoir. The setup also has an online oxygen probe and pH electrode to continuously monitor levels of dissolved oxygen and pH.

With this system, the effects of mass transfer limitations on the reaction rate can be investigated by varying bead size, loading density of beads and flow rate of

Fig. 13 EXPERIMENTAL SETUP OF RECIRCULATION REACTOR

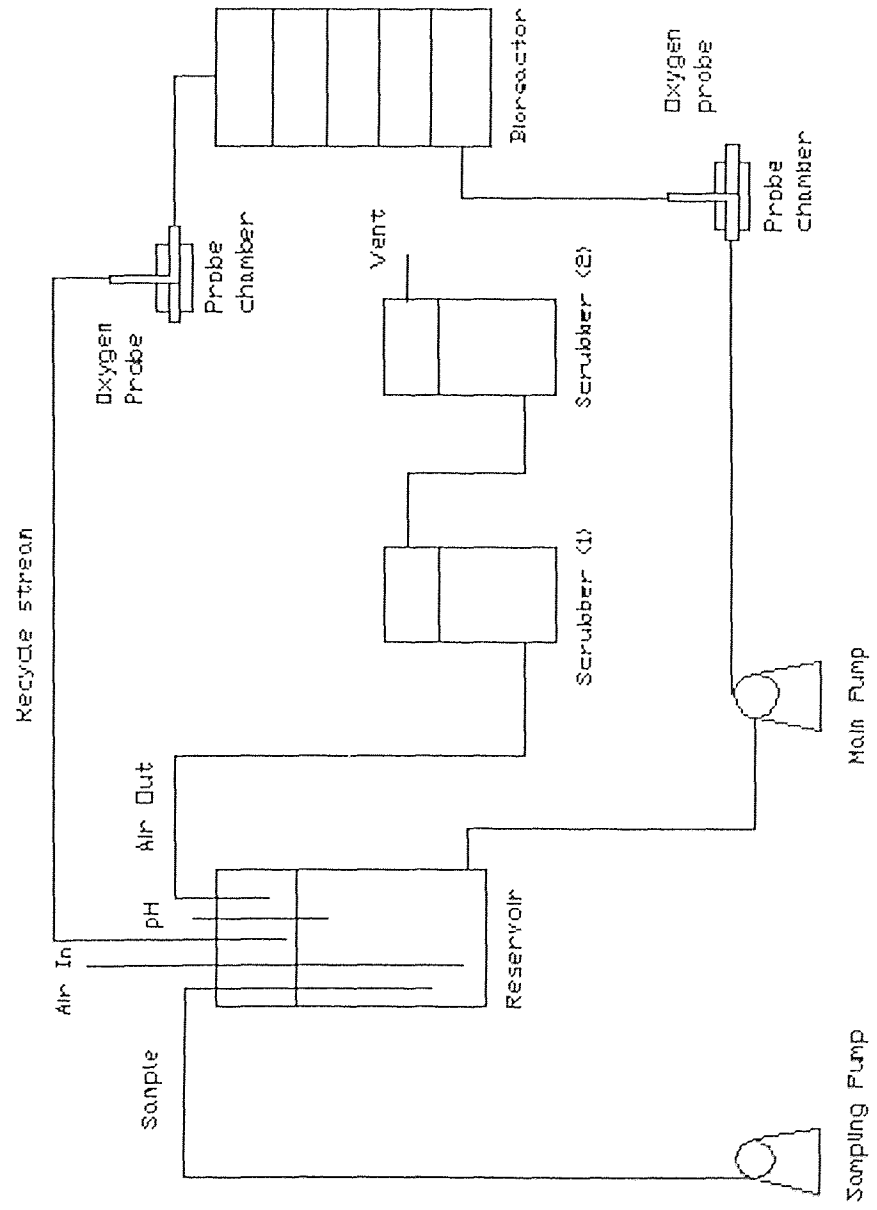

the medium. Other parameters which may have significant influence on activity of immobilized microorganisms, such as temperature, pH, concentration of dissolved oxygen and concentration of toxins, can also be studied. The system facilitates the determination of inherent rate parameters by minimizing internal and external mass transfer resistances, which are of importance in bioreactor design.

Moreover, the system facilitates continuous monitoring of the rate of oxygen consumption, the importance of which has been realized as a co-substrate in aerobic biodegradation.

APPENDIX A

CALCULATION FOR PERCENTAGE SATURATION OF AIR BUBBLES LEAVING
THE REACTOR BY THERMODYNAMIC CONSIDERATIONS.

Reaction volume (V): 300 ml
 Air flow (A): 0.5 l/min
 Temperature (T): 37°C
 Activity coefficient of 2-chlorophenol
 @ 37°C (a_i): 350
 Initial concentration of 2-Chlorophenol (X_o): ..50 ppm
 Final concentration of 2-Chlorophenol (X_f): ... 5 ppm
 Time required to go from 50 to 5 ppm (t_e): ...24 hrs
 Pressure of operation (P): 760 mm Hg
 Vapor pressure of 2-chlorophenol
 @ 37°C (P^o): 4.7 mm Hg
 Density of air @ 37°C (D_a): 1.1438 Kg/m³
 Density of water @ 37°C (D_l): 993.36 Kg/m³

For a non-biological batch system:

$$\frac{d(X \cdot V \cdot D_l)}{d(t)} = - \frac{A \cdot X \cdot P^o \cdot a_i}{P} \dots \dots \dots (1)$$

Assuming Equilibrium:

$$\ln (X_o/X_f) = \frac{A \cdot P^o \cdot a_i \cdot D_g}{P \cdot V \cdot D_l} t \dots\dots\dots(2)$$

where "t" is theoretical time required assuming equilibrium

$$\ln (50/5) = \frac{(0.5 \times 4.7 \times 350 \times 1.1438)}{(0.3 \times 993.36 \times 760)} \times t$$

$$t = 9.24 \text{ hrs}$$

$$\% \text{ Saturation} = \frac{t}{t_e} \times 100$$

$$= \frac{9.24}{24.00} \times 100$$

$$\text{Saturation} = 38.5 \%$$

BIBLIOGRAPHY

1. Dwyer, D.F., Krumme, M.L., Boyd, S.A., and Tiedje, J.M., 1986. "Kinetics of Phenol Degradation by an Immobilized Methanogenic Consortium". *Appl. Environ. Microbiol.*, 52, 345-351.
2. Kennedy, J.F. and Cabral, J.M.S., 1983. "Immobilized Living Cells and their Applications". *Appl. Biochem. Bioeng.*, 4, 189-280.
3. Linko, Y.Y. and Linko, P., 1985. "Immobilized Living Cell Biotechnology". *Proceedings of the 16th FEBS Congress, Part C*, 191-196.
4. Nan K. Chien and Sam S. Sofer, 1985. "Flowrate and Bead Size as Critical Parameters for Immobilized Yeast Reactors". *Enzyme. Microb. Technol.*, 7, 538-542.
5. Kierstan, M. and Buckle, C., 1977. "The Immobilization of Microbial Cells, Subcellular Organelles and Enzymes in Calcium Alginate Gels". *Biotech. Bioeng.*, 19, 387-397.
6. Gaudy, A.F. (Jr) and Gaudy, E.T., 1980. "Microbiology for Environmental Scientists and Engineers". McGraw Hill Book Co., New York, NY.
7. Enfors, S.O. and Mattiason, B., 1983. "Oxygenation of Processes Involving Immobilized Cells", in

Immobilized Cells and Organelles, Vol. II, B. Mattiason, Ed.. CRC Press, Boca Raton, FL. Chap. 3, 41-60.

8. Adlercreutz, P. and Mattiason, B., 1982. "Oxygen Supply to Immobilized Cells. 3 Oxygen supply by Hemoglobin or Emulsions of Perfluorochemicals", *European Journal of Applied Microbiology and Biotechnology*, 16, 165-170.
9. Larson, R.J., Clinckemaille, G.G. and Van Belle, L., 1981. "Effects of Temperature and Dissolved Oxygen on Biodegradation of Nitrilotriacetate". *Water. Res.*, 15, 615-620.
10. Pak, D., "The Biodegradation of Phenolics using Mixed Liquors from Passaic Valley Sewerage Commission Plant, Newark, N.J." M.S. Thesis, New Jersey Institute of Technology, Newark, N.J. 07102, 1985.
11. Chung J. Kim and Walter J. Maier, 1986. "Acclimation and Biodegradation of Chlorinated Organic Compounds in the Presence of Alternate Substrates". *Journal WPCF.*, 58, 157-164.
12. Lewandowski, G., Knox, D. and Pai, P. "The Implications of Vapor-Liquid Equilibrium in the Biodegradation of Hazardous Wastes", 1987. Dept. of Chemical Eng., Chemistry and Environmental Science. N.J. Institute of Technology, Newark, NJ. 07102.

Unpublished Work.

13. Shamat, N.A. and Maier, W.J., 1980. "Kinetics of Biodegradation of Chlorinated Organics". Journal WPCF. 52, 2158-2166.
14. Lewandowski, G., Adamowitz, D., Boyle, P., Gneiding, L., Kim, K., McMullen, N., Pak, D. and Salerno, S.A "Comparison of the Microbial Response of Mixed Liquors from different Treatment Plants to Industrial Organic Chemicals". Presented at the International Conference on Innovative Biological Treatment of Toxic Wastewaters, June 25, 1986, Arlington, VA.
15. Westmeier, F. and Rehm, H.J., 1985. " Biodegradation of 4-Chlorophenol by Entrapped Alcaligenes sp. A7-2". Appl. Microbiol. Biotechnol. 22, 301-308.
16. Klein, J., Hackel, U., and Wagner, F., 1979. "Phenol Degradation by Candida tropicalis whole cells Entrapped in Polymeric Ionic Networks", in Immobilized Microbial Cells, K. Venkatsubramanian Ed.. Acs Symposium Series 106, 101-118.
17. Macaskie, L.E., Wates, J.M. and Dean, A.C.R., 1987. "Cadmium Accumulation by a Citrobacter sp. Immobilized on Gel and Solid Supports: Applicability to the Treatment of Liquid Wastes containing Heavy Metal Cations". Biotech. Bioeng., 30, 66-73.
18. Shaler, T.A. and Klecka, G.M., 1986. "Effects of Dissolved Oxygen Concentrations on Biodegradation of

- 2,4-dichlorophenoxyacetic acid". Applied and Environmental Microbiology, 51, 950-955.
19. Tanaka, H., Matsumura, M. and Veliky, I., 1984. "Diffusion Characteristics of Substrates in Calcium Alginate Gel Beads". Biotech. Bioeng., 26, 53-58.
 20. Gosmann, B. and Rehm, H.J., 1986. "Oxygen Uptake of Microorganisms Entrapped in Calcium Alginate Gel". Appl. Microbiol. Biotechnol., 23, 163-167.
 21. Lurker, P.A., Clark, C.S. and Elia, V.J., 1982. "Atmospheric Release of Chlorinated Organic Compounds from the Activated Sludge Process". Journal WPCF, 54, 1566-1573.
 22. Tischler, L.F. et al., 1979. "Evaluation of the Potential for Air Stripping of Hydrocarbons During the Activated Sludge Wastewater Treatment". Paper presented at WPCF, 52nd Annual Conference, Houston, TX.
 23. Lewandowski, G.A. and Armenante, P.M. "Reactor Design using a White Rot Fungus for Hazardous Waste Treatment". Paper presented at the Workshop on Detoxification of Recalcitrant Organics by Naturally occurring and Genetically Engineered Microorganisms, October 19, 1987, Newark, NJ.
 24. Camp, C.E., "Preliminary Systems and Process Design of a Microsomal Bioreactor", M.S. Thesis, University of Oklahoma, 1985.