

## **Copyright Warning & Restrictions**

The copyright law of the United States (Title 17, United States Code) governs the making of photocopies or other reproductions of copyrighted material.

Under certain conditions specified in the law, libraries and archives are authorized to furnish a photocopy or other reproduction. One of these specified conditions is that the photocopy or reproduction is not to be “used for any purpose other than private study, scholarship, or research.” If a user makes a request for, or later uses, a photocopy or reproduction for purposes in excess of “fair use” that user may be liable for copyright infringement,

This institution reserves the right to refuse to accept a copying order if, in its judgment, fulfillment of the order would involve violation of copyright law.

**Please Note: The author retains the copyright while the New Jersey Institute of Technology reserves the right to distribute this thesis or dissertation**

Printing note: If you do not wish to print this page, then select “Pages from: first page # to: last page #” on the print dialog screen

The Van Houten library has removed some of the personal information and all signatures from the approval page and biographical sketches of theses and dissertations in order to protect the identity of NJIT graduates and faculty.

## **ABSTRACT**

Title of Thesis: "The Architecture of Automobile and Building Design:  
Learning from 100 Years of Parallel Processes"

Vojislav Ristic, Master of Architecture, 1988  
Thesis Directed by: Professor David L. Hawk

The industrial revolution has had a critical impact on society in general and architecture in particular. How we design, build and use buildings is different due to industrial changes in materials, processes and techniques. A key manifestation of the industrial revolution has been the automobile. Since the automobile is a more direct result of application of technique, it is helpful to examine its design to better understand the less direct influences of technique in architecture. This is especially important at a time when the role of technology in architecture is becoming both more significant and more difficult to define and evaluate.

Looking at how various design concepts and objectives have been used in parallel between automobile and building designers is interesting and helpful to designers of both. Each can learn a great deal from the other. This end is aided by examining four noteworthy architects of the past one hundred years that were actively involved in building and automobile design.

Not all of the technological objectives of automobile design have been achieved in its contemporary design. Some of these same objectives appear to have been better realized in building design. Work by some contemporary architects illustrates how this has occurred and how it might be furthered in the interest of improving the quality of future architecture.

**THE ARCHITECTURE OF AUTOMOBILE AND BUILDING DESIGN:  
LEARNING FROM 100 YEARS OF PARALLEL PROCESSES**

by

Vojislav Ristic

Thesis submitted to the Faculty of the Graduate School of the New Jersey Institute  
of Technology in partial fulfillment of the requirements for the degree of Master of Architecture.

1988

APPROVAL SHEET

Title of Thesis: THE ARCHITECTURE OF  
AUTOMOBILE AND BUILDING DESIGN  
LEARNING FROM 100 YEARS OF  
PARALLEL PROCESSES

Name of Candidate: Vojislav Ristic  
Master of Architecture, 1988

Thesis of Abstract Approved: \_\_\_\_\_  
prof. David Hawk Date  
School Of Architecture

Signature of other \_\_\_\_\_  
members of the thesis prof. Michael Mostoller Date  
committee

\_\_\_\_\_ Date  
ass.prof. Bharat Gami

## VITA

Name: Vojislav Ristic  
Permanent Address:

Degree and Date to be Conferred: M.Arch., 1988

Date of Birth:  
Place of Birth:  
Secondary Education: High School D, Tucovic, 1974

Collegiate Institutions Attended:	Dates:	Degree:	Date of Degree:
Belgrade University School of Architecture	1974-80	B.Arch.	1980
New Jersey Institute of Technology, School of Architecture	1986-88	M.Arch	1988

## TABLE OF CONTENTS

I. INTRODUCTION.....	2
II. INDUSTRIAL REVOLUTION-ARCHITECTURE.....	4
III. THE CENTRAL MANIFESTATION OF INDUSTRIALIZATION: THE AUTOMOBILE.....	8
A. Theoretical base	
B. Automobile-development of the constituents	
C. Birth of the automobile	
D. Creating the automobiles place in the society	
IV. LANGUAGE OF ARCHITECTURE-AUTOMOBILE.....	29
A. Listing as design methodology	
B. Asymmetry and Dissonance	
C. Antiperspective Three dimensionality	
D. The Syntax of Four Dimensional Decomposition	
E. Cantilever, Shell and Membrane Structures	
F. Space in Time	
G. Reintegration of Building, City, Landscape	
V. IMPLICATIONS FOR DESIGN.....	45
A. Classical, Traditional, Question of Ornament	
B. Question of Ideology	
C. Can There be a Vernacular Motor Car?	
D. Aesthetic Origins	
VI. ARCHITECTURE - AUTOMOBILE COMPARISON.....	53
A. Basis for Comparison	
B. Comparison	
VII. ARCHITECTS - CAR DESIGNERS.....	74
VIII. THE FUTURE.....	92
BIBLIOGRAPHY.....	98

## I. INTRODUCTION

Two centuries after thoughts on how architecture should adapt to a surrounding technical revolution were first committed to paper there is still doubt as to what such an adaptation means. Has it been achieved? Can it be achieved? Should it be achieved? What would it look like? Debate continues as to the proper role of architecture in today's complex, technologically based world. Debate also continues as to the role of technology in architecture. This paper deals with the issues involved in both debates, since, from inside architecture, the debates are two sides of the same coin. Jacques Ellul set the stage for the debates over two decades ago in his discussion on the role of technique in society.

"Today, technique has taken over the whole of civilization. Certainly, technique is no longer the simple machine substitute for human labor. It has come to be the intervention into the very substance not only of the inorganic but also of the organic. (Ellul, 1964, p. 128)

...technique pursues its own course more and more independently of man...Man is reduced to the level of a catalyst...he resembles a slug inserted into a slot machine: he starts the operation without participating in it...man's covert spiritual activities as well as his own overt actions...must be compelled toward the new integration, thanks to which there is to be no more social maladjustment or neurosis. Man is to be smoothed out, like a pair of pants under a steam iron." (Ellul, 1964, p. 135 & 477)

This frightening scenario of relationships between man and technique, in which man is cast as an inevitable loser, looks real today to many parts of society. Spiritual life and artistic sensitivities, even human mystery, seem hard hit in today's world governed by technique. The role of the artist in this situation is especially interesting. Ellul describes the artist of our day as "...the most impressive witnesses to the fact that a true aesthetic is an impossibility for men whose only alternatives are madness, or pure technique; and this in spite of the existence of powers of artistic invention such as past



civilizations have seldom seen." (Ellul, 1964, p. 404) Kenneth Frampton seems to join in Ellul's discourse by suggesting that architecture and urban planning are very much part of the same contemporary reality.

"Modern building is now so universally conditioned by optimized technology that the possibility of creating significant urban form has become extremely limited. The restrictions jointly imposed by automotive distribution and the volatile play of land speculation serves to limit the scope of urban design to such a degree that any intervention tends to be reduced either to the manipulation of elements predetermined by the imperatives of production, or to a kind of superficial masking which modern development requires for facilitation of marketing and the maintenance of social control. Today the practice of architecture seems to be increasingly polarized between, on the one hand, a so called "high tech" approach predicted exclusively upon production and, on the other hand, the provision of a "compensatory facade" to cover up the harsh realities of this universal system. (Frampton, 1983, p. 17)

Or as Piano outlines his view of the consequences of this situation for architecture and technology:

"...architecture is on the decline, at least in terms of which its work has hitherto been conceived. It is no longer sufficient to update the catalogue of expressive tricks or renew the style code; it is the architect himself that needs to be redesigned. At the most delicate moment, on the brink or entering the microelectronic village, he finds the ground removed from beneath him. He is no longer able to build or invent... Art, though mannered, becomes his refuge and often deteriorates into pure slight of hand, formal arabesques lacking substance...the architects role today is of no use to anyone or anything. He may just as well bow out." (Piano, 1987, p. 7)

The steep pessimism suggested by these words imposes logical questions about the future; not the least of which would be: Is there any real chance for architecture in the world of technique? Although often marked as the universal profession that spans the world of technical and spiritual, architecture is too often caught up in a parochial monologue with itself. Frampton believes this monologue offers only one of two equally unsatisfactory choices:

"Architecture can only be sustained today as a critical practice if it assumes a position which distances itself equally from the Enlightenment myth of progress and from a reactionary, unrealistic impulse to return to the architectonic forms of the preindustrial past." (Frampton, 1983, p. 20)

By feeling insecure outside their own narrow circle or agreement, architects are thus depriving themselves of possible alternatives that lie just outside the profession. Initiating dialogues with professions near and just outside the frontiers of architecture may help us to better understand the architectural side of the frontier. This presents the argument for the thesis - that studying the automobile will help us to know a great deal more about architecture than simply trying to speculate on architecture and its technology.

The automobile, with its gigantic industrial complex of design, production and support has an enormous impact upon the society that relies on it, including design and production of the built environment. I believe that architecture and the automobile have been changing in parallel for the last hundred years. They may even have occasionally crossed each others' paths. The automobile industry has become like a gigantic umbrella that covers a wide range of technologies and aspects of society. It requires the education, talents and efforts of mechanical engineers, physicists, chemists, technologists, architects, artists, economists, electrical engineers, craftsman, advertisers and salespeople. They have all come to center on the object of the automobile.

The process behind this emergence may be interesting and beneficial for architecture to examine. Many of the same disciplines may be important to the future of architecture.

## II. INDUSTRIAL REVOLUTION ARCHITECTURE:

The industrial revolution involved all facets of society. Although it is most often referred to as the era of machine development, it involved many phases beyond simple machines. It required the efforts of production process, economic principles, political structures, family life and public support, value systems, aesthetic ideas and the organization of all of the above.

"...the industrial revolution which was to throw first Britain then the whole world into upheaval, was never at any stage in its career a neatly-definable phenomenon, a combination of given problems occurring in a given area at a given time." (Braudel, 1979, Volume 3, p. 557)

The industrial revolution was a phenomena which occurred while not being a consciously pursued objective. Neither was it a phenomena of individual growth coming from particular sectors of society. It was a simultaneous process including all relevant sectors of society at about the same time. Jacques Ellul, the French sociologist, suggests that the industrial revolution was only one aspect of an all encompassing technical revolution. It systemized and unified society at all levels including fiscal organization and judicial procedures, and even the design and planning of infrastructures.

"...the translation into action of men's concern to master things by means of reason, to account for what is subconscious, to make quantitative what is qualitative, to make clear and precise the outlines of nature, to take hold to chaos and put order into it." (Ellul, 1964, p. 43)

Many thinkers were active participants in eighteenth century efforts to rationalize and lay a conceptual foundation for industrialization. This paved the way for progressive theories and descriptions of what was occurring, and for the possibilities of the automobile as we now know it.

The philosophical seemed to center on humans seen "...as a group of potentially innocent and rational beings." (Trachtenberg, 1986, p. 388) The power of rationality emerged as a principal tool for their discovery of the world around them. There was a philosophical basis in the eighteenth century that provided for intellectual development favoring practical applications of science, where application meant: "...not only to know but also to exploit nature." (Ellul, 1964, p. 46)

Eighteenth-century philosophy also allowed for and may have even nurtured the concept of change. This concept was based on "...a sense of history as something which moves forward through different 'epochs,' each with a spiritual core manifesting itself directly in the facts of the culture." (Curtis, 1985, p. 14)

Out from this came an expectation of a new and original impulse, which in time would become the cultural mainstream of the twentieth century. Confidence in the Renaissance tradition was being gradually lost through growth of an empiricist attitude. Study of archaeology and history reinforced the erosion of the power of Renaissance attitudes. Greater discrimination was encouraged against ideas of tradition. A relativist view was beginning to be adopted to deal with former dictates of what was and was not.

Industrialization brought to architecture a new program with new materials and processes. Alternative methods of construction were possible. As the diversity of life and living styles increased, demand was created for new types of buildings. Factories, railway stations, museums and exhibition pavilions were built with few historical precedents. Iron and glass structures opened up new frontiers in building size and form. New materials and new forms of traditional materials were becoming available at an increasing pace. Changes began to occur in the profession itself. New patrons were found in the emerging middle class for whom architecture became a means of self-expression of new wealth. New ideas were being experimented with to weave together these new structures, materials and client needs.

This technical progress and mechanization changed the world of crafts and caused the collapse of vernacular architecture. A new, more brutal, world seemed to be emerging. This, in turn, raised serious questions about the direction of architectural form and style. "...the problem of architectural style did not exist in isolation, but was related to deeper currents of thought concerning the possibility of creating forms which were not pastiches of past styles but genuine expression of the present." (Curtis, 1985, p. 16)

Leading theorists of the nineteenth century felt that architecture must find its own direction through forms more appropriate to the new social and economic possibilities and conditions. But there was not agreement as to which forms were most appropriate.

Some believed in imitation, while others tried alternative logical frameworks. A suggestion was made to collect the best of all styles. The counter suggestion was to return architecture to its beginning, to the primitive roots of it all. At least some noted that "Within the confused pluralism of the 'battle of styles,' it tended to be forgotten that lasting qualities of architectural excellence were liable to rely, as ever, on characteristics which transcended superficial issues of stylistic clothing." (Curtis, 1985, p. 16) We can now see where machine design, design of technical artifacts, may have been the best representative of this approach.

The emergence of rationalism in the early nineteenth century led J.N.L. Durand to propose that problems should be analyzed not by precedent but on their own merits because beautiful and appropriate forms would necessarily follow from this rationality. Durand's philosophy championed architecture as the servant of public and private utility, and as a major factor for the preservation of individual well-being. Durand formed a system of simple forms, regular and symmetrical schemes of organization and building types, to fit these rules. His selection was unfortunately limited to very basic tradition forms and thus the visualization did not measure up to the potentials implied in the ideas.

Viollet le Duc offered another alternative. He proposed the creation of forms that would be "true to the program and true to the structure." He based his new vision on an understanding of the principles of stylistic development. He accorded Gothic principles the position as the most profound. He analyzed Gothic procedures in detail. But, once again, the results, in terms of buildings and drawings left behind, were a weak answer to the needs to achieve authentic architecture and carry out the ideas of the emerging social agenda. Even though his imagination seemed to not be as strong as his intellect, the theoretical work he accomplished had a great impact on the next generation of architects. In general, architecture was not at the cutting edge of articulating actual

manifestations of the industrial agenda. "When something really new was built in the nineteenth century, it was thought to be 'engineering' and not 'architecture'..."

(Trachtenberg, 1986)

### III. THE CENTRAL MANIFESTATION OF INDUSTRIALIZATION: THE AUTOMOBILE

#### A. Theoretical Basis

Viollet le Duc observed that:

"...naval architects and mechanical engineers do not, when building a steamship or a locomotive, seek to recall the forms of sailing ships or harnessed stage coaches of the Louis XIV period. They obey without question the new principles which are given them and produce their own character and proper style." ( ? )

An issue which builds on le Duc's observation is that "Every invention has its roots in a preceding technical period, and every period bears itself, not only in the trivial residue but in the valuable survivals of past technologies, and the nuclei of new ones."

(Ellul, 1964, p. 47) The idea of a technological complex is a genuinely new formation which consists of a whole set of partial inventions organized around some purpose.

"This unit begins to function when the greatest number of its constituents have been assembled, and its trend is toward continuous self perfection." (Ellul, 1964, p. 47)

This suggests that the long-dormant period of more than ten centuries, with little or no technical development, may have actually been a period of evolution of ideas and parts. At the end of the period the enormous number of inventions was put to use to transmit the technical legacy of one civilization to the next. Since social conditions do not always favor technical progress, the efficient application of technology waits "...to be called on, sometimes several times, to meet a precise and persistent demand." (Braudel, 1979, Vol. 3, p. 567)

Mumford does not believe that technical progress is ever dormant in any real sense, "...it is ripening underground, it is self perpetuating even while it is dormant..." (Ellul, 1964, p. 48). This logic would argue that, although steamships and locomotives were built without obvious precedents, they were not built out of thin air. They came from some basis.

Le Duc looked at technical applications, but even this approach presents shortcomings for explanations. Keeping in mind that technique preceded science, where even in the most primitive societies certain techniques were used in daily life, this still does not account for the emergence of the industrial era. "...technique began to develop itself only after science appeared; to progress technique has to wait for science." (Ellul, 1964, p. 18) Science, on the other hand, is limited to the availability of data known scientifically.

In order to avoid subjective, arbitrary judgment, scientists consider something true if it can be predicted and proven empirically or statistically. "However, an entire realm of effects of technique - indeed, the largest - is not reducible to numbers." Although the problems of machines and steamships can be resolved numerically, the far reaching effects of technique development is not reducible to statistics. There are gaps for creative leaps (used in the scientific sense of Khun) and symbiotic occurrences throughout the process.

Conscious reasoning is a major factor that guides the inventor, scientists and engineer to choose the best option of those known. "It is really a question of finding the best means in the absolute sense, on the basis of numerical calculation." (Ellul, 1964, p. 18), or so it seemed. Accordingly, the specialist is one who chooses the means and demonstrates the superiority of the choice. Technically speaking, there is no room for aesthetic preoccupations in the development of machine design. This provided the

underlying rationale for the emergence of: "A style ... based on the idea that the line best adapted to use is the most beautiful." (Ellul, 1964, p. 73)

This conclusion implies an ascendancy of science and technique in design method, but can architecture exist only as a form of technique? How can numeric calculations account for form in any absolute sense? What about the dilemma hidden in science between cardinal and ordinal measures: Which precedes the other? Is there one line best adapted to use in architecture?

Can architecture live with constantly accelerating change? Obsession with machines continued long after le Duc and inspired a whole generation of architects. The machine age was the motivation of that generation and their theories of design. For some theoreticians, the international movement built around the idea of machine failed to understand the real principles and consequences of the machine age and technical progress of the society.

"...the theory and aesthetics of the International Style were evolved between Futurism and Academism, but their perfection was only achieved by drawing away from Futurism and drawing nearer to the Academic tradition, whether derived from Blanc or Guadet, and by justifying this tendency by Rationalist and Determinist theories of a pre-Futurist type."(Banham, 1960, p. 227)

Some hard-core functionalists, like Buckminster Fuller, who well understood the developing world of technique, suggested it as an "...unhaltable trend to constantly accelerating change."(Fuller, 1960, p. 327) He sharply criticized modernists because he thought that they:

"...demonstrated fashion inoculation without necessary knowledge of the scientific fundamentals of structural mechanics and chemistry. The International Style of 'simplification' was then seen as only superficial. It was seen to only peel off yesterday's exterior embellishments, and instead put on formalized novelties of quasi-symplicity as permitted by the same hidden structural elements of modern alloys that had permitted the discarded Beaux-Arts ornamentation...The new International Stylist hung 'stark motif walls' of vast super meticulous brick assemblage, which had no tensile cohesiveness within it's own bonds, but was, in fact, locked within hidden steel frames supported by steel without visible means of support...the Bauhaus and International Style used standard plumbing fixtures



and only ventured so far as to persuade manufacturers to modify the surface of the valve handles and spigots, and the color, size and arrangements of the tiles...they only looked at problems of modifications of the surface of end products as inherent sub functions of a technically obsolete world."(Banham, 1960, p. 326)

Recent examinations of that period are not very favorable for Fuller. William Curtis accepts Fuller's belief in the honest use and assemblage of technique and function without the impact of aesthetic and symbolic filters, but stops there:

"...as a critique of plumbing and structural veracity of modern architecture, Fuller's criticism may have had a point. But as a structural criticism, his remarks were frankly beside the point. They remind one that, for all the rhetoric used in the twenties concerning the honest expression of function, structure and technology, the game had to go once removed, as it were, in the field of symbolic forms, if the pragmatic was to be translated into art."(Curtis, 1985, p. 187)

In 1960 Reyner Banham observed that if an architect decided to not go along with the technological culture he may find that it has decided to go on without him. But he then ends this comment with a rather ambiguous conclusion:

"It is a choice that the masters of the Twenties failed to observe until they made it by accident, but it is the kind accident that architecture may not survive a second time - we may believe that the architects of the First Machine Age were wrong, but we in the Second Machine Age have no reason yet to be superior about them." (Banham, 1960, p. 530)

Where do we stand today, nearly thirty years after Banham's cautioning remarks? Technical development has accelerated at an ever increasing rate but the actual machine never again really got the attention it deserved. Nearly all the admired objects of the machine age (ships, airplanes and automobiles) are part of our everyday life, some more than ever before. Technically these objects are now much more sophisticated, but can they play the same role when they are used as a source of architectural inspiration? Is Reyner Banham correct when he says that today's designers, whose enthusiasm was fired by the machine age, are without the "wide-eyed" innocence of the architects at work in the Twenties and Thirties?

In today's world the extreme complexities of production in industry distance the designer from the machine as a source of creativity. Technique, and machine as its major exponent, are still sources of inspiration, but as complexity is ever increasing we know less and less about more and more techniques and machines. Surely we know less than Le Corbusier did in his time. Among the many products of the machine age the automobile is probably the most interesting. Owning a car has always been a personal matter, which may be a strong reason for its success, and, although trains, ships and airplanes had a huge impact on society, they never came to be established as an ordinary household possession.

Personal appeal, technical complexity, aesthetic images, and the whole set of new values that came to surround the automobile have made it the symbol of our time. For these same reasons automobile design ought to concern architecture. It certainly can inform architecture.

#### B. Automobile - development of the constituents

The automobile, like all technical formations began to function well "...when the greatest number of its constituents have been assembled..."(Ellul, 1964, p. 47) Its response to the human need to move from one place to another was probably the first necessary constituent for its success.

Primitive society's first venture was to build sleds to accomplish the same end, but they had limited potential. The development of the wheel helped progress beyond these beginnings. The oldest known wheel found in Mesopotamia, dating from the fourth millennium B.C. The Sumerians were first to utilize the wheel, their two-wheeled chariot was a clumsy vehicle but remained the standard model until the Romans improved on it. The Romans constructed more than twenty different varieties of chariots having two or four wheels. They could be used for anything from racing to transportation of goods and

people. Their technique did not develop much beyond that stage; for example, they never engineered forward wheels pivoted on a central axis to help ease turning.

Further development of the wheel did not occur until the fifteenth century. In 1470 a movable front axle, first invented by the Celts, was employed in Europe. Coaches appearing in the second half of the sixteenth century illustrated the emergence of glass windows. Coaches and carriages continued to be improved and developed throughout the seventeenth and eighteenth century. For example, lightness of calash was an alternative for heavy carriages, and the cabriolet (no roof) version was so light it required only two horses to pull it. Frederic William invented the berlin. The berlin cut in half become a coupe. In the eighteenth and nineteenth century the structure of the cabin and suspension enabled carriages to be built with structural lightness and elegance.

Coaches, carriages and carts introduced a new comfortable and attractive mode of personal transportation. At first it was only the privileged classes who benefited. In 1550 Paris had only three carriages. After that carriage mania took hold and by the eighteenth century it spread to the aristocrats, lords and clergy, and then to the bourgeoisie, but development awaiting adequate systems of roads. These were slow in coming. Ocean travel was a great triumph which created a global network of communications but its speed was desperately slow. "Up to the eighteenth century, sea journeys were interminable and overland transport went at a small pace." (Braudel, 1979, Volume I, p. 416)

Nothing or very little would have changed in these matters between the time of Richelieu or Charles V and China under the Sung Dynasty or the Roman Empire.

"...Napoleon moved no faster than Julius Caesar." (Braudel, 1979, Vol. 1, p. 429) Poor

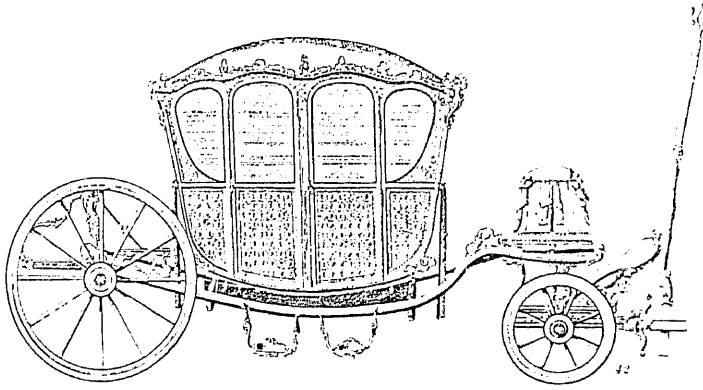

four door berlin

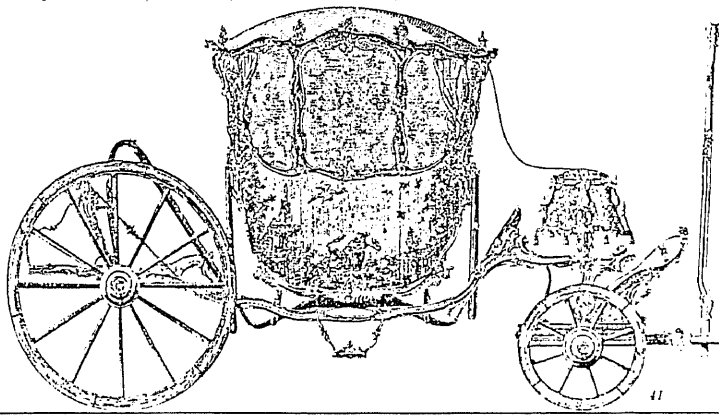

light berlin

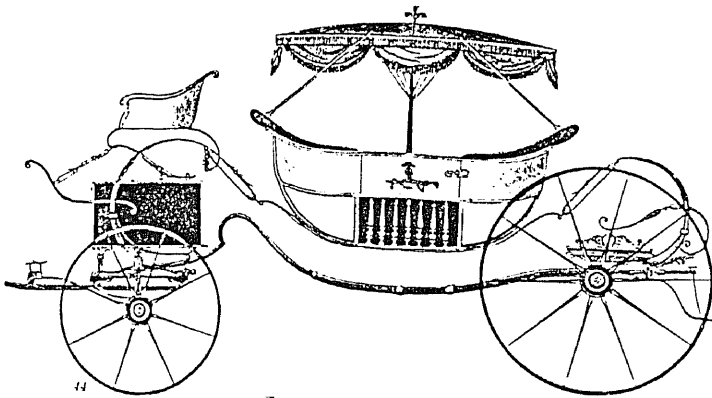

calash

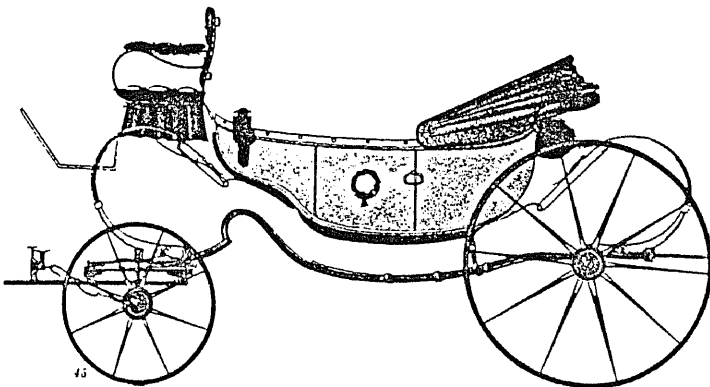

calash

transportation conditions were a burden for economic exchange as well as communication and personal travel. The first system of paved roads appeared in France in the eighteenth century. "The first revolution in road travel was sketched out between 1745 and 1760." (Braudel, 1979, Volume 1, p. 425)

The horse was symbol of speed and almost the only means of traversing great distances and although horse drawn traffic was greatly improved the problem of a stable, potent, movable source of energy was not solved. Man found out very early that his muscles alone didn't provide enough energy to the requirements of most jobs. "...his strength measured in horse-power (seventy-five kilograms to a height of one meter in one second) is derisory: between three and four hundredths of one horsepower against twenty seven to fifty seven hundredths for a cart horse." (Braudel, 1979, Vol. p. 337) The nature of the human mechanics was a serious obstacle.

"The human hand is a comprehensive tool, a grasping instrument. It can seize, hold, press, pull, mold with ease. It can search and feel. Flexibility and articulation are its' key words...Muscles and tendons determine how it will seize and hold an object. It's sensitive skin feels and recognizes materials. The eye steers it's movement. But vital to all this integrating work is the mind that governs and the feelings that lend it life...For all the complicated tasks to which this organic tool may rise, to one thing it is poorly suited: automation...It cannot continue a movement in endless rotation. That is precisely what mechanization entails: endless rotation. The difference between walking and rolling, between the legs and the wheel, is basic to all mechanization." (Giedion, 1968, p. 46)

But man had few options available. At the end of the eighteenth century Europe had, according to Braudel, limited available sources of energy: 10 million horse power from 14 million horses and 2.5 million oxen; 4-5 million horse power from wood; 1.5-3 million horse power from water mills; 900,000 horse power from 50 million workers and 233,000 horse power from sails without counting the war fleets. By the end of eighteenth century the stage was set for the coming of the industrial revolution. It was the result of

the growth based on a very slow increase in power, strength and a practical understanding of scientific inventions that laid the foundation for it.

Lack of a sufficient sources of energy was not always the cause of stagnation in a society. Sometimes it was a problem in putting available sources of energy to work. For example, steam as a source of energy was not utilized until long after its discovery. Steam was first harnessed in Ptolemaic Alexandria between 100 and 50 B.C. as a method for opening and closing heavy temple doors. But in general nobody seemed to need more powerful sources of energy than those already being used. Thus, steam had to wait for need needs and new times. Seventeen centuries later, in 1698, Thomas Savery patented a simple steam pump. In 1712 Thomas Newcomen built the first stationary steam engine, a viable steam pumping engine for the coal mines. Newcomen developed his engine from an understanding of the forces involved, as based on long experience, and, although some believe that he must have used a model to develop his machine, no drawings were ever found and no calculations were left behind.

Newcomen had no formal education and was far removed socially from the world of scholars. In fact, he was disqualified and almost deprived of his invention. His genius was discredited as explained in the following except from an article on steam engines: "...after a great many laborious attempts, they did make the engine work; but not being either philosophers to understanding the reason, or mathematicians enough to calculate the powers, and to proportion the parts, very luckily by accident found what they sought for." (Baynes and Pugh, 1984, p. 34)

This was actually a rather typical example of science preceded by technique. The invention helped explain the thermodynamic phenomenon on which engine work relied. From this basis more efficient engines could be invented.

Newcomens engine was a big and sturdy affair, built in brick with a wooded beam, a copper boiler, a tin cylinder and lead piping. James Watt revolutionized

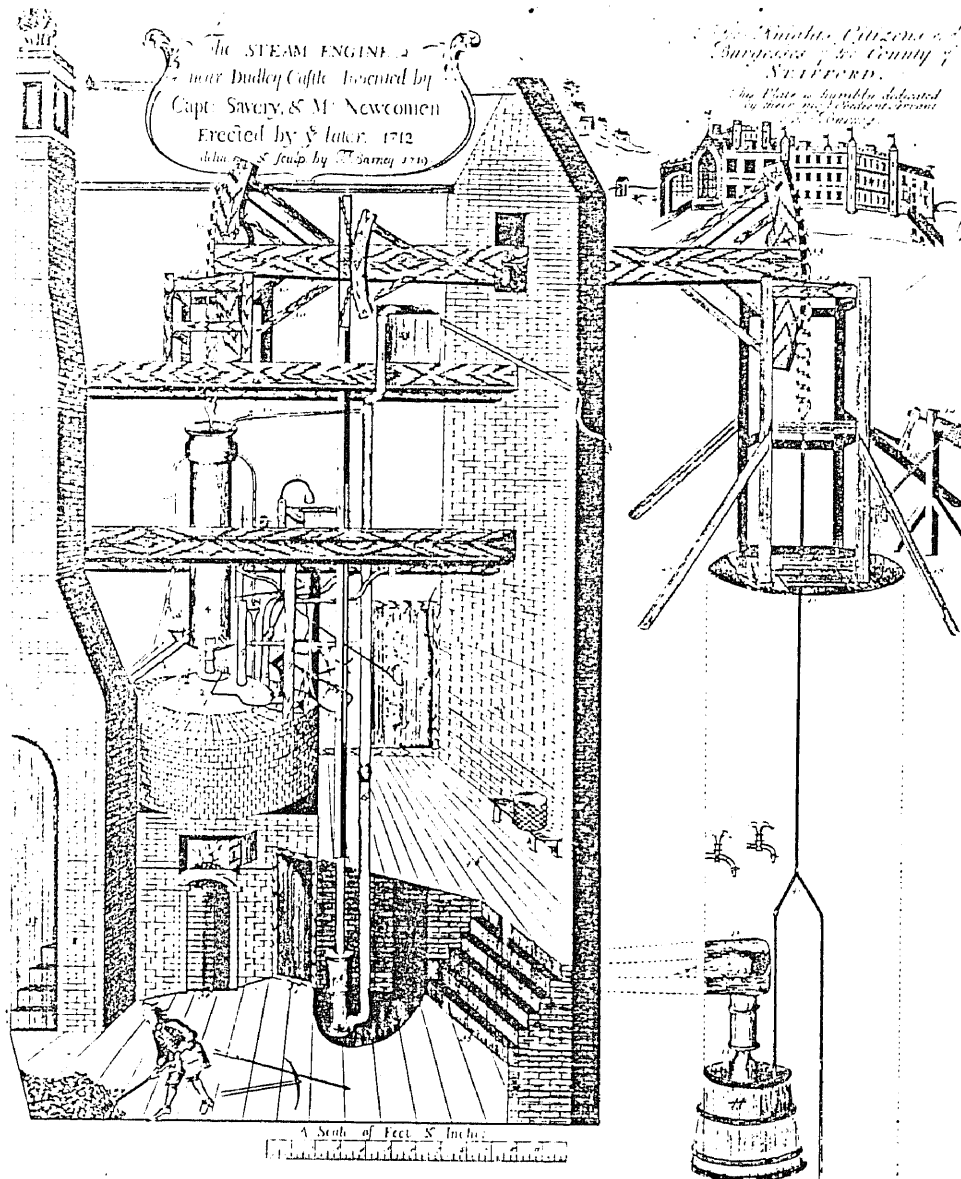

52  
The Newcomen engine at Dudley Castle  
engraved by Thomas Barneij, 1719.  
Crown Copyright, Science Museum, London

Newcomen's engine by the application of a separate condenser, thus reducing fuel consumption and making the steam engine commercially interesting. Further improvements made it smaller, lighter and more powerful but perhaps not yet powerful enough. In the early nineteenth century Philippe Lebon took a revolutionary step, planning to move a piston by exploding a mixture of air and lightning gas. Numerous experiments followed, more or less unsuccessful, until 1860 when the first stationary engines were fired by explosive fuel, as designed by the Frenchman Jean Joseph Etienne Lenoir. The Scientific American wrote in 1860 that, "The age of steam is ended - Watt and Fulton will soon be forgotten. This is the way they do such things in France." (Georgano, 1983, p. 9)

However, it was too early to predict the success of the internal combustion engine. Until this point it was a failure. Even so, it was a great inspiration for young engineers who saw something new on the horizon. In the mid-1860s, another Frenchman, Alphonse Beau de Rochas patented a four stroke internal combustion engine, but as history often writes strange stories, another man, Gottlieb Daimler (with Wilhelm Maybach as a contributor) received the credit. The owner of the firm for which Daimler and Maybach worked, Nikolaus August Otto, patented the four-stroke internal combustion engine in 1876. This engine is today known as the Otto engine.

### C. Birth of the Automobile

Even before the steam and internal combustion engines were invented there were numerous attempts to produce a carriage powered by something other than raw animal power. Mechanical chariots moved by the efforts of men hidden inside turning cranks were popular in the parades of the early sixteenth century. An Englishman, George Pocock, made a so called "flying chariot" in 1826, pulled by a train of kites, of course without horses. It became almost an obsession to produce a carriage driven without



horses. The power of wind was explored by using sails, kites or other strange devices mounted on carriages but they were insufficiently powered and impractical. The first steam carriage built in 1769 was large, clumsy and could go no faster than five miles per hour. Watt's assistant, William Murdock, made a lighter, smaller steam carriage in 1784. In 1804 Oliver Evans made a huge amphibious vehicle equipped with a wheel for land travel and paddle wheels for the water.

The steam engine was heavy, complicated to use and not sufficiently powerful to operate anything more than very simple devices. Electricity seemed to be a probably solution and although the vehicles were fast and strong enough, the batteries needed were quite heavy, and had to be recharged frequently. In 1860 Lenoir made yet another attempt by installing his gas engine to a three wheeled carriage. One of these vehicles was sold to Alexander II, Tsar of Russia. Internal combustion engines in the late nineteenth century were used mostly as stationary engines. Despite the fact that there was very prosperous business interests in having vehicles powered by internal combustion engines, they seemed not to take off just yet. After experiments made in the late summer of 1886, Gottlieb Daimler and Karl Benz, independent of each other, made trials with a carriage powered by an internal combustion engine. Thus, the automobile was born.

It was not widely accepted at the onset, and no one realized at first how significant this development might become. The early, funny, noisy vehicles were a source of amazement for most people. Even engineers were not optimistic about the prospects. Karl Benz's partners feared that his obsession with the automobile was a pointless experiment. He didn't give up. Encouragement often came from unexpected sides. For example, Benz's wife, Bertha, without Karl's knowledge, persuaded their fifteen year old son to drive their car to visit relatives in Pforzheim 50 miles away from their home in

First automobiles with internal combustion engines

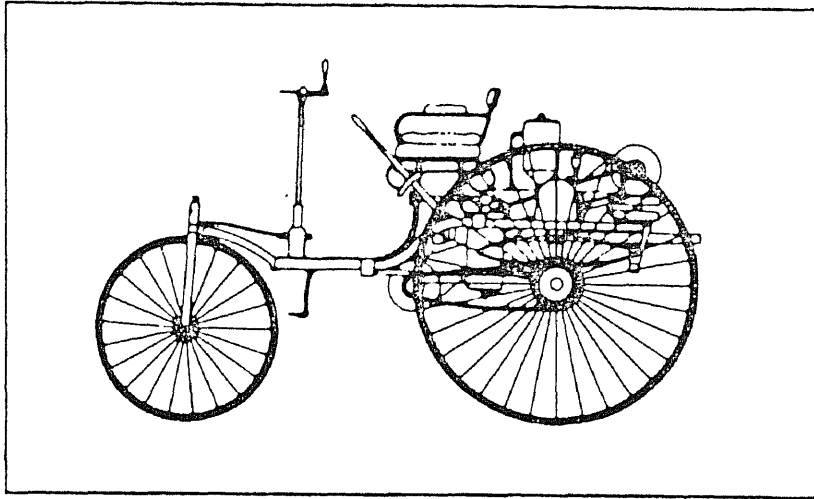

Benz three wheeler

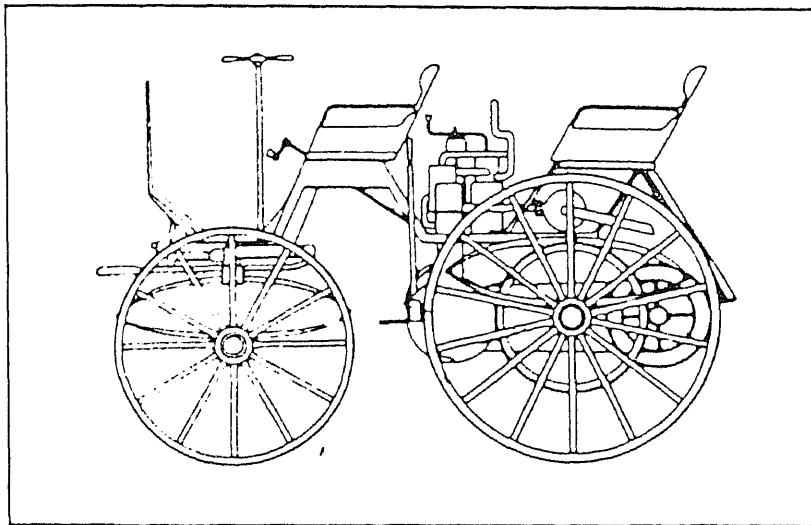

Daimler a converted horse drawn carriage

Manheim. She was a well educated woman and capable of attending to all mechanical problems which might occur during the trip. This was the first long distance journey made by car rather than by conventional trains.

These few isolated experiments grew into a world wide phenomena whose complex and diverse effects have proven to touch on almost all facets of human life. No other means of transportation in this century has had the same impact on human society and the individual.

#### D. Creating A Place for Automobiles in Society

Engineering and technology were the foundation for the development of the motor vehicle. Further engine, transmission, brakes and suspension design were needed in order for the car to operate properly. A whole generation of technically educated innovative individuals would become responsible for perfecting the first meager ventures. During the pioneering days car owners had to be mechanics and engineers, and their fascination with the car's technical and mechanical aspects proved helpful to solve a lost list of problems that arose.

As the number of cars increased the attitude towards cars in society changed. Their influence in society proved to be important far beyond the significant technical accomplishments. It became a market item that was produced by different companies in competition for a growing body of customers.

Advertisement helped to create a market for the image and fact of the car. According to the sociologist Ellul, advertising became a "...phenomenon of involuntary psychological collectivization." (Ellul, 1964, p. 406) It became a force in adopting man to the mass. Ellul refers to the purpose of advertising as "...the creation of a certain way of life. And here it is much less important to convince the individual rationally than to implant in him certain conceptions of life." (Ellul, 1964, p.406) One of the great designs of advertising is to create needs; but this is possible only if these needs correspond to an

ideal of life that man accepts. The general need for transportation within a society is part of human nature, but the more specific need for an automobile is part of a larger and more complex picture that may well characterize the global society. In the eighteenth century the myth of progress was created around beliefs that happiness and justice would result from scientific investigations and technical applications. This myth became the fertile ground for transformations of civilization in the nineteenth century. Transformation of civilization was explained by Ellul as the conjunction in time of five phenomena: "The fruition of a long technical experience; population expansion; the suitability of the economic environment; the plasticity of the social milieu; and the appearance of a clear technical intention." (Ellul, 1964, p. 47)

Still, for the success of the automobile to become more specific, it had to offer personal issues that could be considered as a "... way of life. This was made all the more easy in marketing the automobile in that it corresponded to certain easy and simple tendencies of man, and referenced a world in which there were not spiritual values to form and inform life." (Ellul, 1964, p. 407)

The car became a very complex and inspirational object that could change its role to fit a changing society. Analysis of advertisement illustrates the car's changing role in society. In the first years, advertising focused on what is today described as the nuts and bolts approach. The intent was to reassure the customer that the car was easy to handle and would not explode or rush away. For the Rambler of 1905 there was a slogan "A mechanism so simple so that the boy of the family can operate it." (Georgano, 1985, p. 207) For the Oldsmobile of 1903 the advertising stated that "Ladies and children can readily understand it's mechanism." (Georgano, 1985, p. 207)

Another strategy was to compare the automobile with the object that was well-know - the horse. In 1910 Oldsmobile announced: "This graceful and practical automobile will do the work of six horses at an average cost of thirty-five dollars a year

(for 10,000 miles). Board alone for one horse would cost \$180 a year, so the economy is obvious. The Oldsmobile owner has the additional satisfaction of knowing that his machine is always ready." (Georgano, 1985, p. 207)

Advertising also reflected a fascination with the cars technical features like in a Cadillac commercial from 1910 there was the comment: "There are 112 parts of the Cadillac, 30 of which are accurate to one thousandth of an inch." (Georgano, 1985, p. 207)(This offered a "high-tech" image.) Speed and racing become favorite themes with which to capture peoples attention; especially prospective buyers.

In 1912 the Pierce Arrow started a new trend with advertising through "atmospheric" posters. These emphasized, without words, the car's all-around cosmopolitan abilities. They put cars within elegant settings at the opera, at an aviation meet, or in European Nurenberg. In 1915 Cadillac produced their philosophical advertising paper called "The Penalty of Leadership," and Packard offered quotations of John Ruskin. Jordon relied on a series of commercials which put emphasis on romance and escapism. The most famous of these was, "Somewhere West of Laramie." Many others followed that offered other destinations for escapism and outdoor romance. One popular ad ran: "I am sick of four walls and a ceiling. I have business with the sunshine and the summer wind. I am weary of dishes and doctors. I am tired of going to stores and helping with meals. I am going somewhere if it is the last thing I ever do in my life. Give me a Blue Silhouette Jordan, summer days, uncluttered hours, mountains, landscape, far silhouette plains, freedom, relaxation, moonlight on the open road..." (Georgano, 1985, p. 212)

A variation of this approach is still in practice today. For example, a song from the latest Mazda commercial says, "Go where you want to go, do what you want to do." and is followed by a red convertible, cruising around picturesque hills and rocky and wild ocean coast. Pleasures and escapism are central.

Patentirt in allen Industriestaaten!

Neu! Praktisch!

## Patent-Motorwagen

mit Gasbetrieb durch Petroleum, Benzin, Naphta etc.

Immer sogleich betriebsfähig! — Bequem und absolut gefahrlos!

Vollständiger Ersatz für Wagen mit Pferden.  
Erspart ein Kütcher, ein hüner Ausattung, Wartung und Unter-  
haltung von Pferden.



Leichter, Halter und Bremsen leichter und schneller.  
Kein besonderer Bedienung nötig.  
Sehr geringer Verbrauch.

Patent-Motorwagen mit abnehmbarem Halbverdeck und Spritzleder.

# BENZ & Co.

Rheinische Gasmotoren-Fabrik  
MANNHEIM.  
Neue Fabrik Waldhofstrasse.

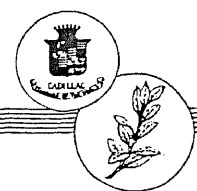

## The Penalty of Leadership

**I**N EVERY field of human endeavor, he that is first must perpetually live in the white light of publicity.

Whether the leadership be vested in a man or in a manufactured product, emulation and envy are ever at work.

In art, in literature, in music, in industry, the reward and the punishment are always the same.

The reward is widespread recognition; the punishment, fierce denial and detraction.

When a man's work becomes a standard for the whole world, it also becomes a target for the shafts of the envious few.

If his work be merely mediocre, he will be left severely alone—if he achieves a masterpiece, it will set a million tongues a-wagging.

Jalousy does not protrude its forked tongue at the artist who produces a commonplace painting.

Whoever you write, or paint, or play, or sing, or build, no one will strive to surpass or to slander you unless your work be stamped with the seal of genius.

Long, long after a great work or a good work has been done, those who are disappointed or envious, continue to cry out that it cannot be done.

Spiteful little voices in the domain of art were raised against our own Whistler as a mountebank, long after the big world had acclaimed him its greatest artistic genius.

Multitudes flocked to Bayreuth to worship at the musical shrine of Wagner, while the little group of those whom he had dethroned and displaced argued angrily that he was no musician at all.

The little world continued to protest that Fulton could never build a steam-boat, while the big world flocked to the river banks to see his boat steam by.

The leader is assailed because he is a leader, and the effort to equal him is merely added proof of that leadership.

Failing to equal or to excel, the follower seeks to depreciate and to destroy—but only confirms once more the superiority of that which he strives to supplant.

There is nothing new in this.

It is as old as the world and as old as the human passions—envy, fear, greed, ambition, and the desire to surpass.

And it all avails nothing.

If the leader truly leads, he remains—the leader.

Master-poet, master-painter, master-workman, each in his turn is assailed, and each holds his laurels through the ages.

That which is good or great makes itself known, no matter how loud the clamor of denial.

That which deserves to live—lives.



## Somewhere West of Laramie

**S**OMEWHERE west of Laramie there's a broncho-busting, steer roping girl who knows what I'm talking about. She can tell what a sassy pony, that's a cross between greased lightning and the place where it hits, can do with eleven hundred pounds of steel and action when he's going high, wide and handsome.

The truth is—the Playboy was built for her.

Built for the lass whose face is brown with the sun when the day is done of revel and romp and race.

She loves the cross of the wild and the tame.

There's a savor of links about that car—of laughter and lilt and light—a hint of old loves—and saddle and quirt. It's a brassy thing—yet a grateful thing for the sweep o' the Avenue.

Step into the Playboy when the hour grows dull with things gone dead and stale.

Then start for the land of real living with the spirit of the lass who rides, lean and rangy, into the red horizon of a Wyoming twilight.



# JORDAN

JORDAN MOTOR CAR COMPANY, Grand Rapids, Michigan

*ALL works of taste must bear a price in proportion to the skill, time, expense and risk attending their invention and manufacture. Those things called dear are, when justly estimated, the cheapest. They are attended with much less profit to the artist than those which everybody calls cheap. A disposition for cheapness and not for excellence of workmanship is the most frequent and certain cause of the decay and destruction of arts and manufactures.*

—RUSKIN

Packard  
2-38 Coupe

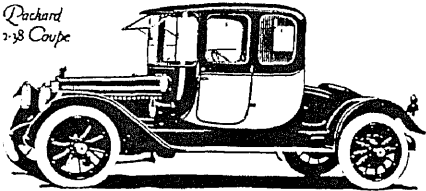

*Ask the man who owns one*  
PACKARD · MOTOR · CAR · COMPANY · DETROIT

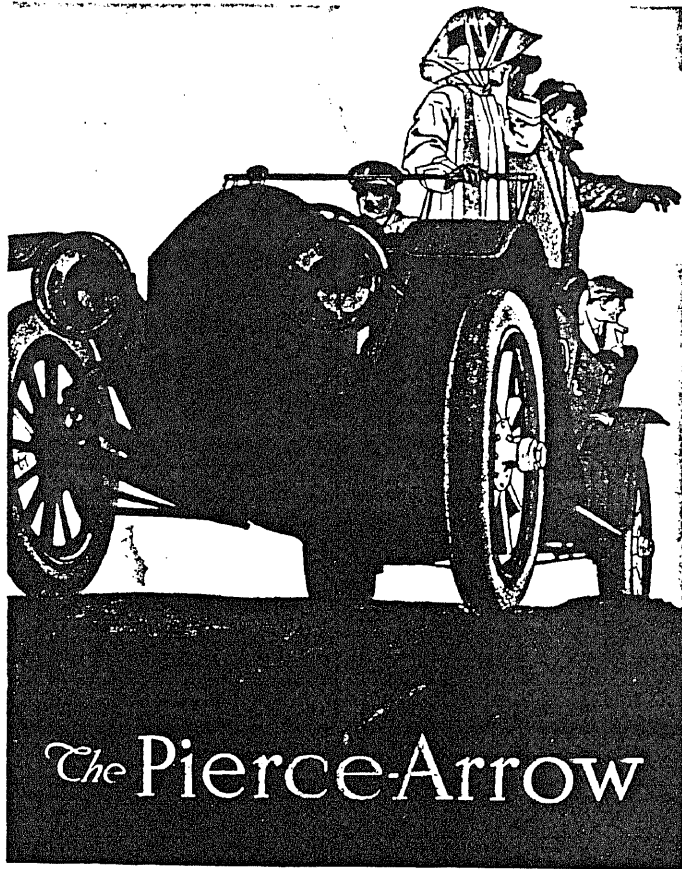

The Pierce-Arrow at the Aviation Meet

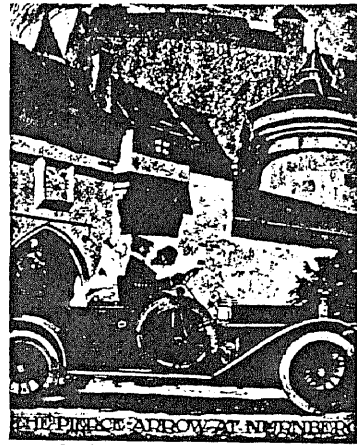

# Pierce-Arrow

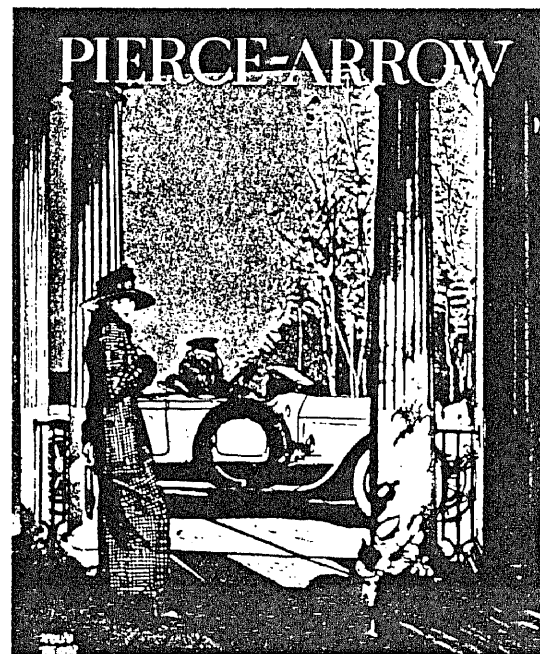
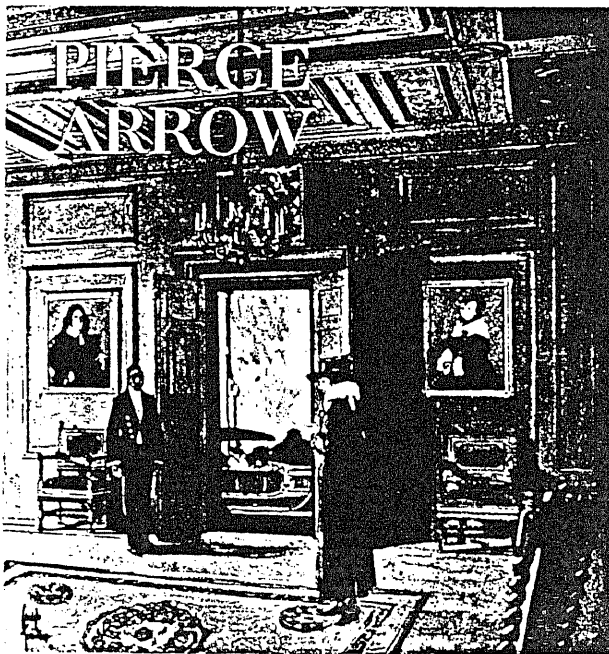
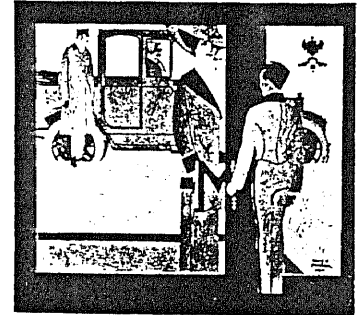

Advertising superior technological achievements is characteristic of BMW and Mercedes. One of their commercials is skillfully arranged with a potential collision on a mountain road, but with luck and thanks to the BMW's ALS (anti-lock-system) brakes, state of the art technology, it is avoided. In the case of Mercedes, a series of computerized drawings lead us through the multilink suspension system illustrating traction and stability on road views.

Both BMW and Mercedes are very successful in upholding the image of luxury and high society involvement of their cars. BMW commercials show their car as a discrete element in a large picture dominated by elegance, luxury and splendor. Porsche builds on this and goes on to depict their car flying along a curved road and performing impossible turnarounds that ignore the basic laws of physics. Porsche capitalizes on a restless nature and the promise of high-speed adventure.

The image of the Corvette is a legend seemingly implanted in the human psyche, and inherited in generation after generation. The slogan: "Corvette from Hell, 380 horsepower, six-speed gearbox. We drive it. You should!" is coupled with an image of a yellow car standing on a red hot lava like substance.

Numerous four wheel drive, off-the-road vehicles are creating and perhaps responding to a macho image. Ready to conquer, wild, rough and heading for nature provides the image material. Although for many the wilderness ends on main street, it is a fantasy that persists.

"Volvo" takes another approach in its advertising campaign. They explain evolution and the nature of the human body through that evolution, concluding that the only protection offered to the human species is intelligence and "intelligent people that help themselves by driving Volvos." The commercial presents driving as a natural development of the evolutionary chain, just after walking. It modestly suggest that the car is the missing link in evolution which left humans without firm physical protection. The Volvo is sold as a kind of exoskeleton.



Time after time the automobile is offered as capable of being everywhere and doing everything. It is not only part of everyday human life, but is life itself. Automobiles have become an inevitable part of our lives. As Giedion remarked, automobiles entered "into intimate living and became a movable part of the household." (Giedion, 1948, p. 43) Moreover, people have developed special relationships with their automobiles as with no other household possession.

What is then the nature of this relationship? It has been explained as a "...special, spiritual relationship that exists between people and between people. For that matter, people are just about everything that people purposefully create existed from the time when people started to make things." (Jacobs, 1981, p. 9) Sociologists have recognized that the world in which we live is "not only a material but also a spiritual world, that forces us actions in it which are unknown and perhaps unknowable; that there are phenomena in it which man interprets as magical; that there are relations are correspondences between things and beings in which material connections are of little consequence." The automobile is a product of technical means and efforts and therefore has autonomy which doesn't recognize the sacred or mysterious in nature, but "...man cannot live without the sacred. He therefore transfers his sense of the sacred to the very things which has destroyed its former object: the technique itself." (Ellul, 1964, p. 143)

"The sacred that man experiences in the face of technique is the care he takes to treat it with familiarity...but for all men the feeling of the sacred is expressed in this marvelous instrument of the power instinct which is always joined to mystery and magic." (Ellul, 1964, p. 145) For the young man speeding along at 100 mPH in the Porsche "...technique is in every way sacred; it is the common expression of human power without which he would find himself poor, alone, naked, and stripped of all pretensions.

He would no longer be the hero, genius, or archangel which a motor permits him to be at little expense." (Ellul, 1964, p. 145)

Although the automobile fits easily enough into the object of the power myth, it has one feature that is inconsistent - that of the aesthetic.

#### IV. THE LANGUAGE OF ARCHITECTURE-AUTOMOBILE

"Without a language, we cannot speak. What is more, it is language that 'speaks for us', in the sense that it provides the instruments of communication without which it would be impossible even to work out our thoughts. Yet in the course of centuries only one architectural language has been codified, that of classicism." (Zevi, 1978, p. 3)

Architecture in this century is still dominated by the movement we commonly call Modernism. It is the movement largely based on avant gard culture which assumed different roles over the period of almost two centuries.

"...at times facilitating the process of modernization and thereby acting, in part, as a progressive, liberative form, and at times being verulently opposed to the positivism of bourgeois culture. Architectural avant gard largely played positive role...with regard to the progressive trajectory of the Enlightenment." (Frampton, 1985, p.18)

Different theoreticians have characterized the movement differently. Zevi puts strong emphasis on it's opposition to classicism, based on Greek Classical architecture, Juger Habermas points out a different phenomenon of the modern.

"...The emphatically modern document no longer borrows this power of being classic from the authority of a past epoch; instead a modern work becomes a classic because it has once been authentically modern... The relation between "modern" and "classical has definitely lost a fixed historical reference." (Habermas, 1983, p. 4)

Even Post Modernism is part of the Modernism despite a sharp anti orientation towards it. Some explain it as "the end game of avant gardism" and the decline of "critical adversary culture". (Huyssens, 1983, p. 19) Frampton describes their orientation as gravitation towards pure technique or pure scenography. Jenks, spokesperson for the movement describes it as: "the style is hybrid, double-coated, based on fundamental dualities..highly developed taste for paradox is characteristic of our time and sensibility" (Jencks, 1976, p.5)

In "Complexity and Contradiction in Architecture" Venturi points out eternal architectural values in a new light. It is a language that doesn't recognize "Movements" or ideologies and although he modestly suggests that it is "A Gentle Manifesto", the book presents a thoughtful analysis that opens the eyes and mind, too often obscured by ideological nonsense.

Indeed how should we define modern building? Zevi, an outspoken modernist advocate, rejects The International Style as a dictatorial. He accepts only masterworks of the movement which are often founded on very different principles. Zevi recognizes more than one language within the movement, and although they have common ground in their revolt against classicism the revolt of each one is expressed differently. It is for this reason that Zevi's codification of the language of the modern architecture is considered flexible. Zevi called it "A Guide to the Anticlassical Code." It is difficult to clearly differentiate between Zevi, Venturi and Jencks because they often take a similar stand and even use the same buildings in order to prove their beliefs.

The automobile, as an object, is based on certain principles. While it is relatively easy to explain a cars technical aspect, the formal appearance is not so simple a story.

The ambition of this work is not to define the exclusive language of car design, rather the automobile will be analyzed according to architectural criteria, by examining ideas of by leading theoreticians like: Zevi, Venturi, Jencks. By applying their architectural principles to the automobile I will explore the possible connections between the automobile and architecture. Zevi's seven invariables will serve as the starting points for this analysis.

#### A. Listing as Design Methodology

"The list, or inventory, of functions is the generating principle of the modern language in architecture, and it subsumes all other principles...Implicit in listing, or compiling an inventory of functions, is the dismantling and critical rejection of classical rules, "orders", and kind... it demands a new beginning, as if no linguistic system had ever existed before, as if were the first time in history that we had to build a house or a city." (Zevi, 1978, p. 7)

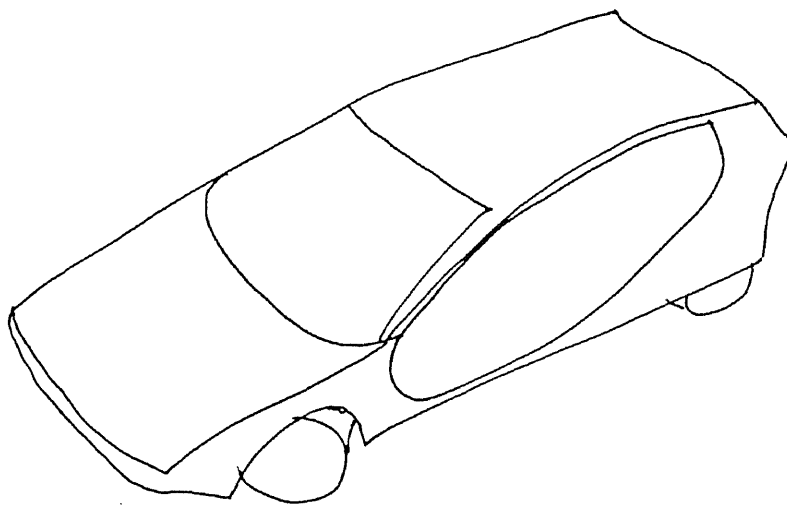
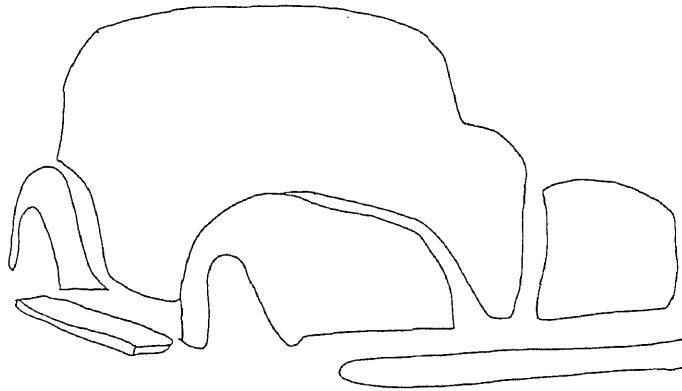
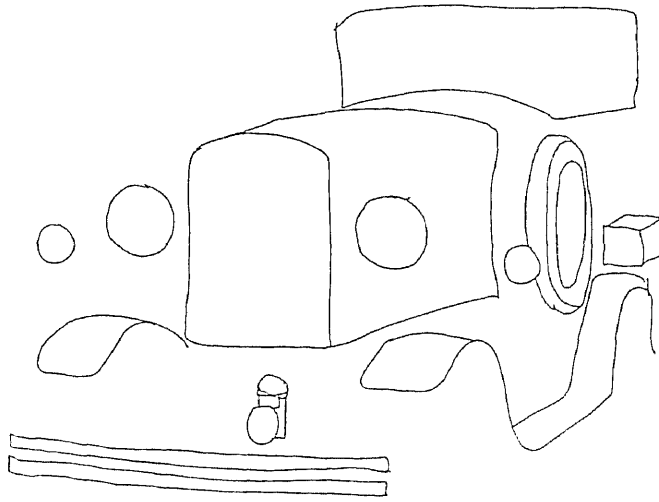

Development of  
form  
from elementary  
unitary

This principle, as described by Zevi, is applied to every aspect of design, on any scale "...volumes and spaces, their interrelationship, urban complexes, and regional planning." (Zevi, 1978, p.12) The functional list is in contrast to the general notion of geometry such as straight lines and right angles.

Venturi wrote with a slightly different viewpoint about the same issue.

"I like elements which are hybrid rather than "pure", compromising rather than "clean", distorted rather than "straightforward", ambiguous rather than "articulated", perverse as well as impersonal, boring as well as interesting, ...I am for messy vitality over obvious unity." (Venturi, 1967, p. 16)

Automobiles are essentially an assembly of various functional elements: cabin, fenders, bumpers, headlamps, trunk and wheels. Historically the overall form of car design has depended very much upon the treatment of these elements. Until the 1930's the various elements were treated separately and were aesthetically independent of each other. Further development brought greater unification of elements, first by inserting transitional elements at connecting points and then by merging elements into larger elements until their separateness became nearly indistinguishable. The car became one unified form, carved and notched, within which earlier elements remained present only as symbolic lines. The automobile was, from the beginning, a curvilinear entity, with little room for straight lines or right angles.

Zevi's principle quite clearly suggests that the form of the automobile, in architectural terms, went from modern to classical. Venturi's principle of contradiction is interesting but in and of itself doesn't apply very well to design evaluation. It is certainly true that many elements can contribute to a successful form, but this gives no guarantee of success. Venturi's principle "More is not Less." doesn't amount to much of aesthetic value.

According to Jencks, the car as a unified form still retains its metaphoric values. Probably it does, but automobiles may have lost their formal complexity and informality of meaning over the years. Greater uniformity has resulted in so many similar forms, thus individuality and complexity have been greatly reduced. Automobiles have not however lost their technical and structural complexity, which is increasing all the time. Although the construction of the overall simplistic form and technical complexity is interesting it has not had favorable results for the automobile in general.

## B. Asymmetry and Dissonance

Zevi was very concerned about the aspect of symmetry. Although he admits that not all symmetrical buildings are rhetorical, he makes the observation that most classical buildings are symmetrical along one axis.

"Antigeometry and free form, and therefore asymmetry and antiparallelism, are invariables of the modern language of architecture. They mark emancipation through dissonance." (Zevi, 1978, p. 22)

The automobile is a dynamic object which moves through space. It moves in a straight or curved path, resists the wind (front, side, back) and stops efficiently whenever necessary. Balance of all technical aspects is important feature that all automobiles must have. Symmetry is very closely related to all previously mentioned features and nature is our teacher, giving useful examples of symmetrical dynamic form. Birds cannot fly with one wing nor can animals animals with three legs run. But the automobile is not a creature of nature and its need for balance must be proved through calculations. That brings us back to symmetry and its problems.

One aspect of symmetry in automobiles is weight distribution which must be balanced as much as possible. But this does not necessarily mean symmetry of

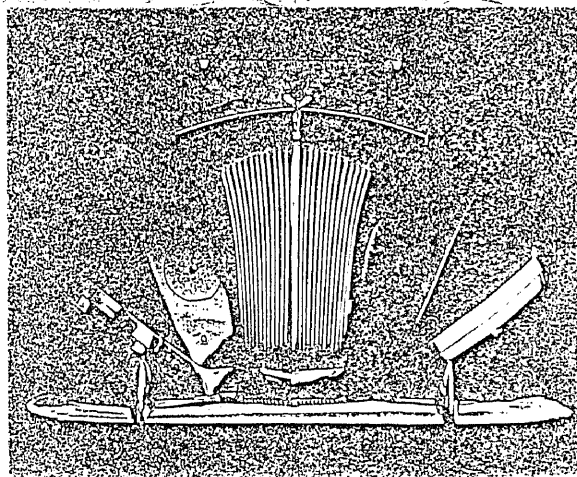
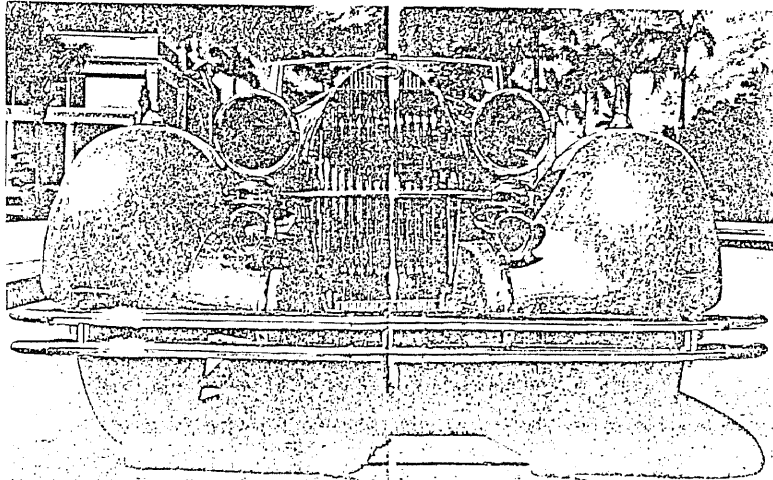
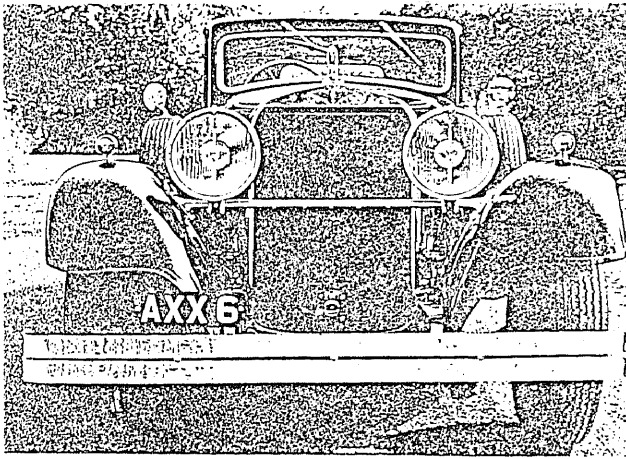

Symbolism  
very strong  
on the front  
elevation



resultant form. Typically the automobile is symmetrical along its lengthwise axis and according to Zevi's criteria it is classified automobile as less of a rhetoric and degenerate object than one which is totally symmetrical. But even so, the classification is still not favorable to the problem. Can we have an automobile that is asymmetrical in both directions?

The common wisdom of the car's mechanical system (engine, transmission, radiator) does not require symmetry but the overall form has remained almost totally symmetrical. The only asymmetry we can find on automobiles today is that of minor intervention. Venturi would call this kind of asymmetry "the contradiction adapter", in other words, a tolerant and pliable asymmetry which admits improvisation. It involves the disintegration of a prototype-and it ends in "approximation and qualification". No one has attempted to apply greater asymmetry to car design. It has been treated within certain limits because the automobile is closely connected with the twin problems of friction and balance. Although, automobiles that operate at slower speeds can certainly pay less attention to air resistance than very fast sports cars.

The automobile has a very strong symbolic character. Its symmetry closely relates to body images and man's continuity with the natural and animal kingdoms. In Jung's terms:

"The animal motif is usually symbolic of man's primitive and instinctual nature. In religion and religious art of practically every culture, animal attributes are ascribed to the supreme gods, or the gods are represented as animals. The boundless profusion of animal symbolism in the religion and art of all times does not merely emphasize the importance of the symbol; it shows how vital it is for men to integrate into their lives the symbol's psychic content - instinct. In itself an animal is neither good or evil; it is a piece of nature. It cannot desire anything that is not in its nature...it obeys its instincts. These instincts often seem mysterious to us, but they have their parallel in human life: The foundation of human nature is instinct." (Jung, 1964, p. 265)

So, it is possible to say that symmetry plays an important role for the automobile not only in the area of technical criteria? The question of symmetry is not so simple. Besides static symmetry there is dynamic symmetry, first used by the Egyptians and then by the Greeks.

"Dynamic symmetry in nature is the type of orderly arrangement of members of an organism such as we find in a shell or the adjustment of leaves on a plant. There is a great difference between this and the static type. The dynamic is a symmetry suggestive of life and movement. It's great value to design lies in it's power of transition or movement from one form to another in the system". (Hambridge, 1961, p.10)

Existing stereotypes about how a certain object should look become strong obstacles for any kind of change. We have a hard time accepting something that doesn't fit our aesthetic preconceptions. The stereotype of the automobile has a strong influence on its design and design in general. Here we don't have a psychic/spiritual stereotype, but rather a mass market stereotype. We can hardly mistake the identity of a fast sports car for an ordinary one, or a luxurious for a less luxurious model. Thanks to stereotypes we can be fooled. Many times we are the object of manipulation. Stereotypes about the automobile are usually a product of the manufacturing monopoly and advertising industry which seeks to control mass society but mass society does not reduce human consciousness to a herd of cows. Individuality and variety are still very important issues for the modern consumer and hunger for symbolism is strong enough to create a need for a great variety in the types of available symbols.

Automobile stereotypes can be recreated if more varieties of form are present. Asymmetry can play an important role in the creation of these forms for the future.

### C. Antiperspective Three-Dimensionality

"Perspective is a drawing technique for representing three-dimensional objects on a two-dimensional surface. To make the job easier, buildings were broken down into squared parts and reduced to regular prisms. An immense visual heritage of curves, asymmetric forms, swerving lines, modulations, and angles other than 90 degree was obliterated in one fell swoop. The world was turned into boxes, and

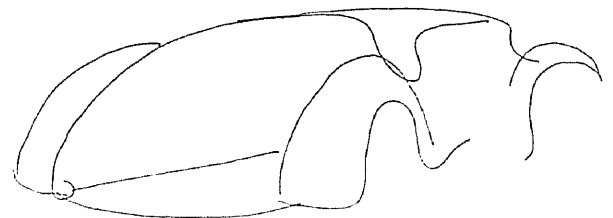
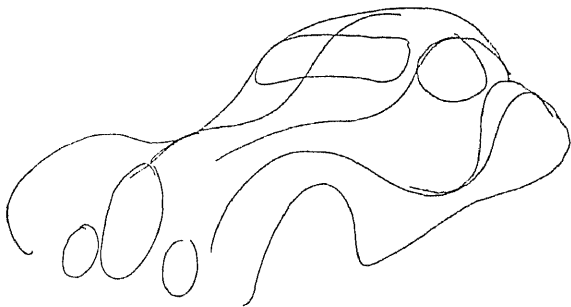
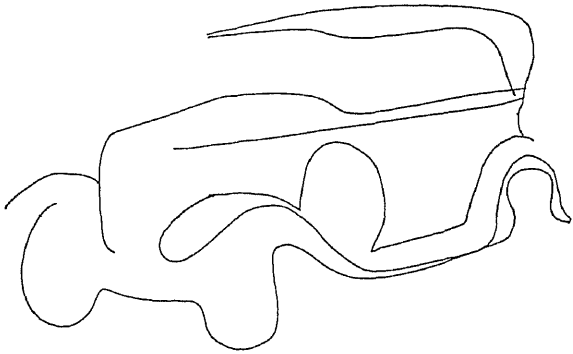
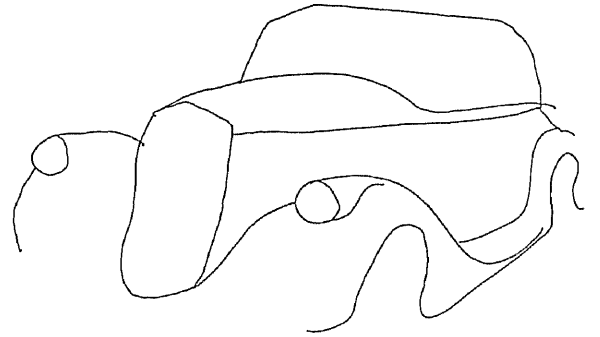
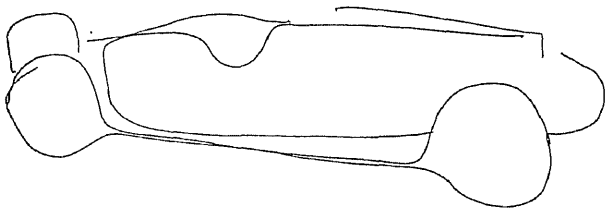
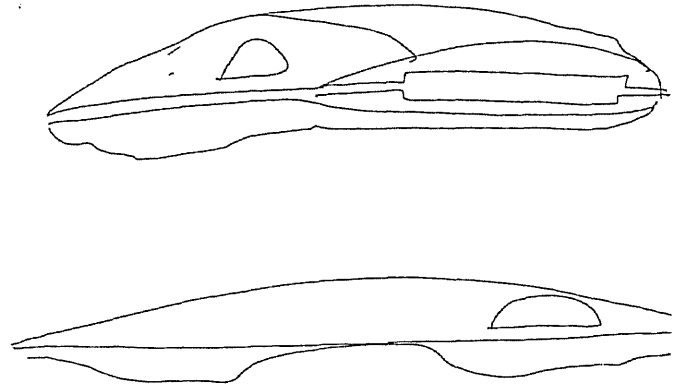
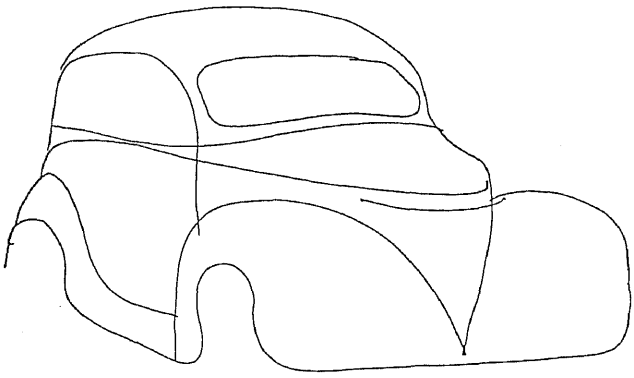

Curvilinear three dimensionality

the architectural "orders" were used to distinguish superimposed or juxtaposed parts of the box. Instead of providing a means of acquiring greater awareness of three dimensionality ...it rigidified three dimensionality to such a degree that drawing it has become something mechanical and almost useless." (Zevi, 1978, p. 23)

There is no question about the Zevi's point as to the importance of perspective in emphasizing the three-dimensional aspects of the building but the negative role of perspective is debatable. It is simple to draw boxes in perspective but it is hard to believe that boxes were designed just because the architect was too lazy to draw curves.

Venturi takes a different position, analyzing the building with the distinction between the duck and the decorated shed. The duck is a building "Where the architectural system of space, structure and program are submerged and distorted by an overall symbolic form" (Venturi, 1972) and decorated shed is a building "Where system of space and structure are directly at the service of program, and ornament is applied independently of them." (Venturi, 1972) For Venturi both kinds of architecture are valid but he prefers "...the decorated shed with a rhetorical front and conventional behind." (Venturi, 1972) Although he doesn't explicitly discuss three-dimensionality, he obviously gives it secondary importance. Venturi was sharply criticized by Jencks for suggesting in the name of rationality such an exclusive and simplistic path.

Humans can observe the automobile easily from virtually all sides and from many different angles with rich perceptual abilities widening and sharpening the aesthetic criteria. As our ability to enjoy aesthetics of lines and overall form improves if we are able to improve our powers of observation.

In the design process the front, side and back elevations are not the only matters of consideration, the meeting points and corners are even more important. Very often the front, side and back elevations are the least pleasing elements of the car. They reveal something that the human eye can't observe because we receive the aesthetic

impression of an automobile while watching it in motion, from different angles, always having its three-dimensional contour in sight.

The automobile's curvilinear aesthetics make it a very complex object visually. Historically, as the car's form changed from an assemblage of different aesthetic, almost independent, elements, to a unitary form shaped and carved from one piece, the problem of three dimensionality became quite complex. Speed is perhaps the most important element influencing form. To move faster a car needs power but also a form which provides less air resistance. A smooth surface is preferable to a rough, a soft line is better than a box.

In architecture, Mendelsohn's early conceptual sketches, his visions of future forms, reveal the automobile's spirit as we know it today.

"Mendelsohn's images do not use the Cubist four dimensionality, but they exalt the principle of movement through corner visions and dynamic materials. His expressionism is so violent that the three dimensional perspective block destroys any static solemnity and explodes, electrifies, and magnetizes the landscape."  
(Zevi, 1978, p. 29)

#### D. The Syntax of Four dimensional Decomposition

"If the problem is to get rid of the perspective block, the first thing to do is eliminate the third dimension by decomposing the box, breaking it up into panels. No more closed volumes. What happens to a room? It is no longer a cubic void."  
(Zevi, 1978, p. 31)

Applying this principle to the evolution of the automobile it is easy to conclude that it experienced a retrograde process of development. Form went from more to less varied, from a decomposed box to a cubic void, then ...by the year 1930 the range of available body types was probably wider than at any time before or since." (Beattie, 1977) Economic crises and very strong mass production ideas undermined and diluted the multiformity of body types. The advantage of mass production was the low retail price, and greater affordability meant more people could afford to buy a car of which fewer models were available.

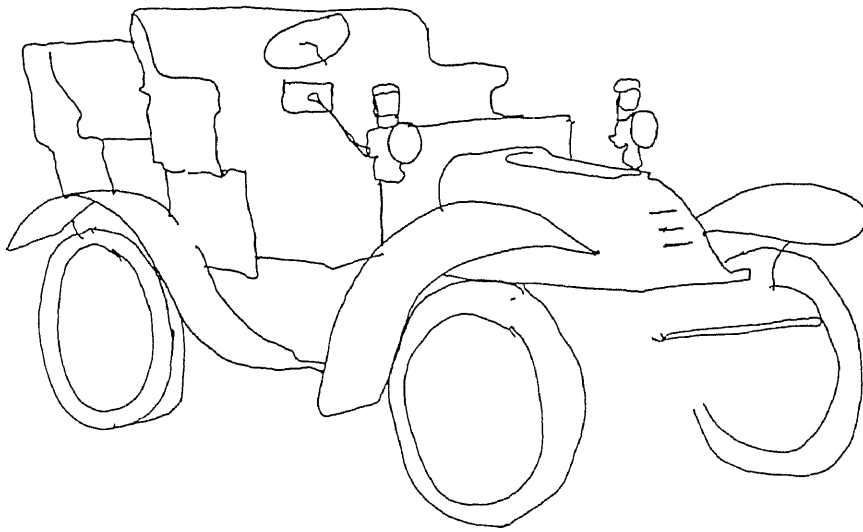

Old automobile versus new one - very contrast compositions

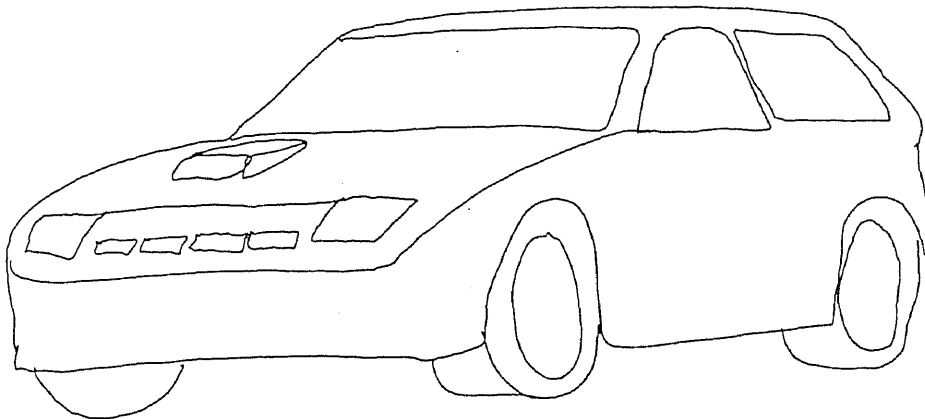

The development of design was moving continually toward compositional unity and abstraction. Can we have a decomposed automobile? Yes, but there is an interesting parallel that must first be made. During 1920's the automobile was very frequently singled out and compared with architecture. Reyner Banham believed that at that time "...automobiles were visibly comparable to the Parthenon." (Banham, 1960, 328) During 1930's "streamline" fever shook the whole area of design. It was based on the laws of hydrodynamics concerning forms that can penetrate air and water with the least resistance. Forms are:

"...simplified by the design principle of absorption, the merging of one sub-form into another with transitional curves, and reductivism, the elimination of extraneous details." (Busch, 1975, p.1)

Much of modern design was effected by this trend, especially automobiles. Sharp lines were replaced with soft lines and the overall form resembled organic forms in nature. Banham saw that: "As soon as performance made it necessary to pack the components of a vehicle into a compact streamlined shell, the visual link between the International Style and technology was broken."

The question raised at that time and still pertinent today is whether architecture should take note of technological development more closely and more seriously. As far as automobile streamlining is concerned very few models managed to reach a desirable form. It became a rather naive effort on the part of many designers who failed to understand aerodynamics, thus the streamlining issue eventually vanished. Automobile forms, for a long period of time, remained essentially static. Even the avantgardism as manifested in streamline form was abandoned.

## E. Cantilever, Shell and Member Structures

"..the outer angles of a box were not where its most economical support would be...a certain distance in each way from each corner is where the economic support of a box building is invariably to be found...When you put support at those points you have created a short cantileverage to the corners that lessens actual spans and sets the corner free or open for whatever distance you choose. The corners disappear altogether if you choose to let space come in there, or let it go out...in this simple change of thought lies the essence of the architectural change from box to free plan and the new reality that is space instead of matter..." (Zevi, 1978, p. 39)

Automobile shell structure development went through different phases. The wood frame was replaced with a steel chassis bearing first wood and then a steel cabin and finally the shell became self supportive.

The self supportive shell, made according to the principle of unit construction, is a complicated assembly of steel pressings that become the base structure for attachment of exterior panels. The whole shell is built section by section "...in high power presses by stamping flat sheet steel into shape between a pair of heavy steel dies with corresponding contours." (Norbye, 1984, p. 114) When well-formed, sheet metal becomes strong and stiff relative to its weight. Its thickness is less than 1/20 of an inch in most cases. At crucial points the unit body is reinforced with light steel pressing, boxed or U profile, providing great bending stiffness in one or more planes for a modest increase in weight. This description of today's automobile structure corresponds well with Zevi's position.

"The codification of the modern language of architecture implies that engineers as well as architects must shuck the chains of classicism and bring to an end the long conflict between technique and expression, which must be used together in creative fashion. The structural invariable of the modern idiom is less concerned with cantilevers, membranes, and shells than it is with involving all the architectural elements in a symphony of static forces." (Zevi, 1978, pp. 40-3)

## F. Space in Time

"The sixth invariable of the modern language is space in time, space that is truly lived in, ready to act and be acted on... Space in time is the summary of the problem in a nutshell... Einstein says that an event is localized not only in time but also in space... What it means is the following invariable: open design that is constantly in process, invested with time consciousness, and unfinished." (Zevi, 1978, p. 53)



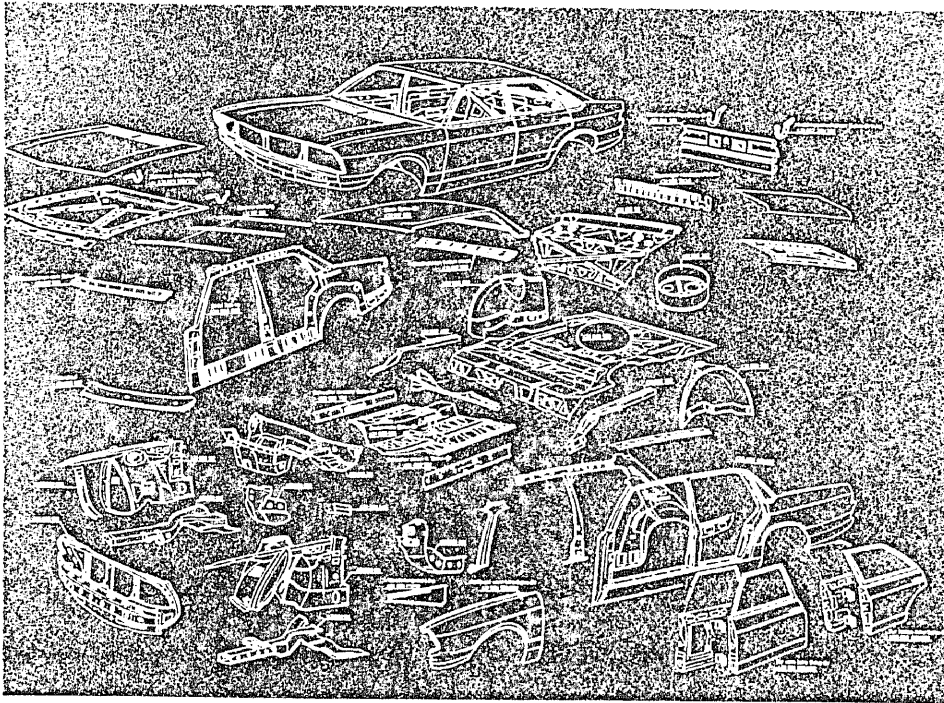

Fig 7-3. The separate pressings that go into making an Audi body shell.

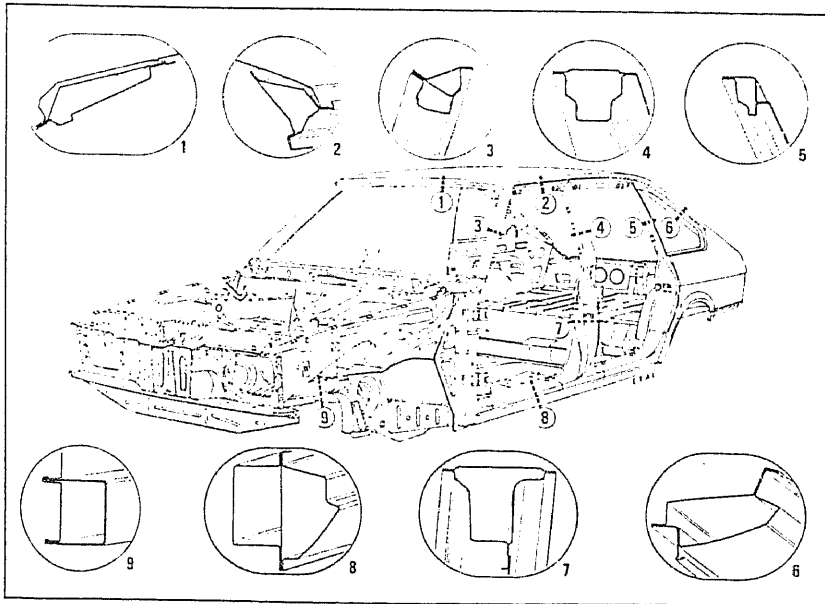

Fig. 7-4. How reinforcements are made without adding massive steel parts.

In the sense of form, the automobile's antiperspective three dimensionality corresponds to the Space in Time invariable. "Antiperspective is another consequence of space in time, because it means constantly changing the viewing point." (Zevi, 1978, p. 50) The automobile is exactly this kind of object, constantly changing while moving through space. Our experience within the automobile's interior is static, since the interior is designed to seat two to six persons, usually in parallel rows, facing forward. Active experience is present during interaction with the environment when the automobile is in motion. Speed is the crucial factor that allows us to actively experience the surrounding space. Einstein's theory of relativity explains what changes occur when movement through space approaches the speed of light. While we wait to live through that experience, available land vehicles provide us with speed excitement.

Speed is not unique to automobiles. It is a unique experience when compared to the less personal aspects of speed on a train or bus, and less direct when compared to a motorcycle. Speed is by definition a relative value dependent on the length of road and the time on it. In every life, these terms depend on the conditions of road, traffic, weather etc. We can have a very picturesque, relaxing visual experience on a deserted mountain road and a very mechanical, close to madness experience, on a high-speed highway. As we move through the environment the picture is constantly changing.

At the beginning of this century, even before the automobile was established as a ordinary personal possession, Futurists emphasized speed in their fourth proposal.

"We declare that the splendor of the world has been enriched by a new beauty, beauty of speed. A racing car with its bonnet draped with exhaust pipes like fire-breathing serpents-a roaring racing car, rattling along like a machine gun, is more beautiful than the winged victory of Samothrace." (Zevi, 1978, p.51)

Speed is that special invariable of the automobile language that adds new dimension to the movement of space through time. It is a metaphor of the mechanized world we live in.

## G. Reintegration of Building, City, Landscape

"Reintegration of city and region implies a dialogue between architecture and it's natural environment." (Zevi, 1978, 60) On this point automobile can be analyzed en masse, as a movable object, a phenomenon of movement. Automobiles are everywhere, they are an inseparable part of our everyday life and their influence on the urban scene is tremendous. Streets, boulevards, parking lots, garages, freeways parkways, bridges, tunnels are all built to accommodate the movement of traffic. Urban standards, themselves, have altered to accommodate the automobile and parking space is in many instances the utmost priority. The architecture of buildings is definitely defeated in suburban business districts and shopping centers. The result of the pressure created by the presence of the automobile is isolation and the disintegration of cities but it is not only the city that suffers, the automobile is also losing. The appeal of freedom created by the open road is lost in heavy traffic jams or when there are no parking places available.

Urban space and the automobile could peacefully coexist if some concept of urban design could be found to deal more successfully with automobiles. Reintegration of the automobile is threatened by its negative features, mainly noise pollution and parking, and ultimately the question of reintegration is also the question of the future of the automobile.

## V. IMPLICATIONS FOR DESIGN

### A. Classical, Traditional, Question of Ornament

The idea of classical design doesn't have the same meaning for automobiles as it does for architecture. After all, the automobile is only a hundred years old. Automobile historians define four stylistic periods in the history of the motor car: -

- Veteran (until 1904)
- Edwardian (1905-1917)
- Vintage (1918-1930)
- Post-War (1945-forward)

The categories are peculiar to automobiles but the overall taste, and preferences of society in the field of art, craft and architecture during those periods obviously had an influence on the development of the automobile.

The influence is most obvious with regard to interior decoration and ornamentation on both the exterior and interior. Style was never strictly obeyed, instead a mixture of styles emerged, neo-classical, neo-baroque and various mixtures of these and other styles.

Most of the exterior parts were stacked onto a projected front end. Buckminster Fuller used to ridicule the Rolls Royce by saying "who could respect a car that attempted to gain prestige by stuffing a chrome miniature of a Greek temple through the air?" (Automobile, July, 1988, p. 109) Ridiculous or not, the Rolls Royce still has its temple-front grill, although somewhat modified.

Sophisticated materials that were used in home decoration have also been used in the construction of automobiles. Fine wood, cashmere, silk, leather, brass and chrome were inevitably part of the image and they remain a symbol of luxury to the present day.

It is difficult to pinpoint the use of ornamentation in automobile design, because there is a wide range of treatments to consider, from eclectic to clean modernist. Taste and style changed over the years and many ornaments developed into a more abstract version or their original form. Different design philosophies employed ornaments differently. The European style is clean and elegant, with less chrome. Americans love to pile on chrome anywhere they can find a place for it. Plastic leathers often cover the solid metal body, faking a convertible, and posing for luxury. The Japanese are flexible, and follow closely the taste of consumers around the globe.

Many natural materials have been replaced with plastic imitation. Today, plastic imitations abound and the automobile has incorporated the use of many plastics in its construction. Most recent of these is plastic leather which has all the advantages of leather without the disadvantages. Specialized automobile magazines have assimilated improvements made in the development of plastics with an interesting linguistic switch. Plastic began by with implications of cheapness, but as it seemed to inevitably take over, it is changing. Quality is now being measured by the level of success of the imitation, not by the material used to imitate.

#### B. Question of Ideology

Automobile design has had few if any problems with ideology since it was never consciously defined as part of any traditional ideological system. Automobile became an ideology in and of itself. This seems to be different in architecture. The ideological ping-pong that existed within the modern movement of architecture has been reiterated in the post modern era. The argument that there is no such thing as an ideological architecture is too often lost in heated and not very thoughtful discussion based on ideologies. Perhaps a close look at automobiles and comparison with the ideas behind them could help in clarifying this. The two central questions would be:

Is there ideological architecture?

Is there an ideological automobile?

The automobile has been in some sense removed from the arena of ideological battles. For example the Volkswagan "beetle" was literally supervised and even drawn by Hitler yet it went on to become the most popular automobile on the planet. Its ideological associations were forgotten or forgiven.

An example of there being a design logic peculiar to automobiles is seen in the fact that today's political officials (presidents, ministers, senators,...) are without exception, always seen being driven in black automobiles. The size is big, the color is

black, and the brand is not terribly important.

Why black? It is another part of the motor car mystique. After all, kings and queens used to have coaches as colorful and kitschy as they could be, so how did "modern royalty" come to select black?

### C. Can There be a Vernacular Motor Car?

A vernacular motor car, why not? The definition of it would be a vehicle used in the countryside, rough, tough and durable with four-wheel drive, and many make shift elements. It requires only basic industrial output and good dry pine boards in the back yard.

The pick up truck and station wagon could be raw models for vernacular cars. Old pickup trucks were actually constructed with back sides made of wood boards, clearly stating it's origins. Station wagons also had wood used in exterior construction but wood was gradually replaced by wood decoration attached to a metal body. Today we can see ugly wood imitations attached to the metal body of the car. Today's pickup trucks can be listed as "neo-vernacular". Jencks explained in architectural terms that "...vernacular wasn't straight revivalist, not accurate reproduction but "quasi"..." (Jencks, 1976, p. 96)

Renzo Piano designed a kind of vernacular car named the "Flying Carpet". It had a ferro cement platform with attached wheels and engine. Only the construction of the wheels and engine required special facilities, everything else could be built at home with no special skill necessary. Piano proposed this as a method for the motorization of the African nations.

### D. Aesthetic origins

In order to compete in the animal world humans have had to recognize and make up for their own physical vulnerability. Compared to animals, humans are not fast

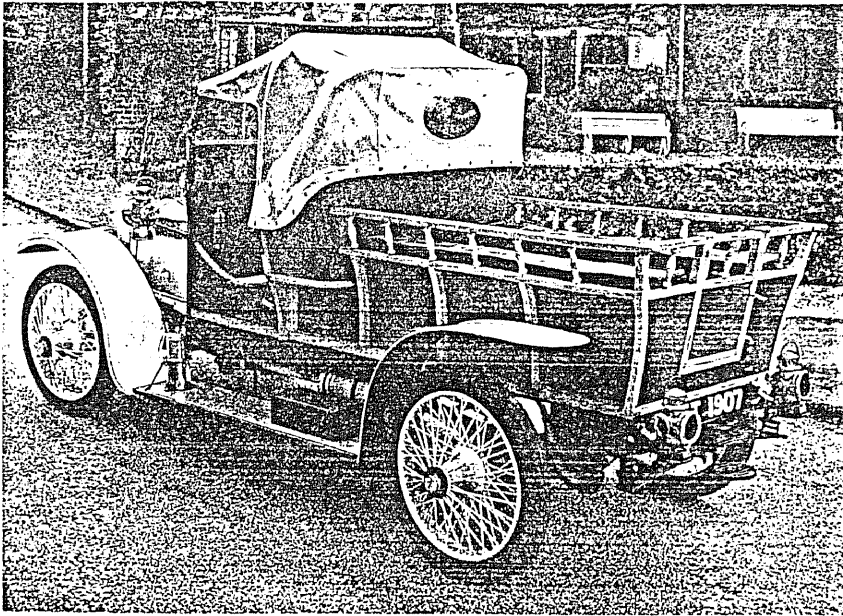

1913 Napier

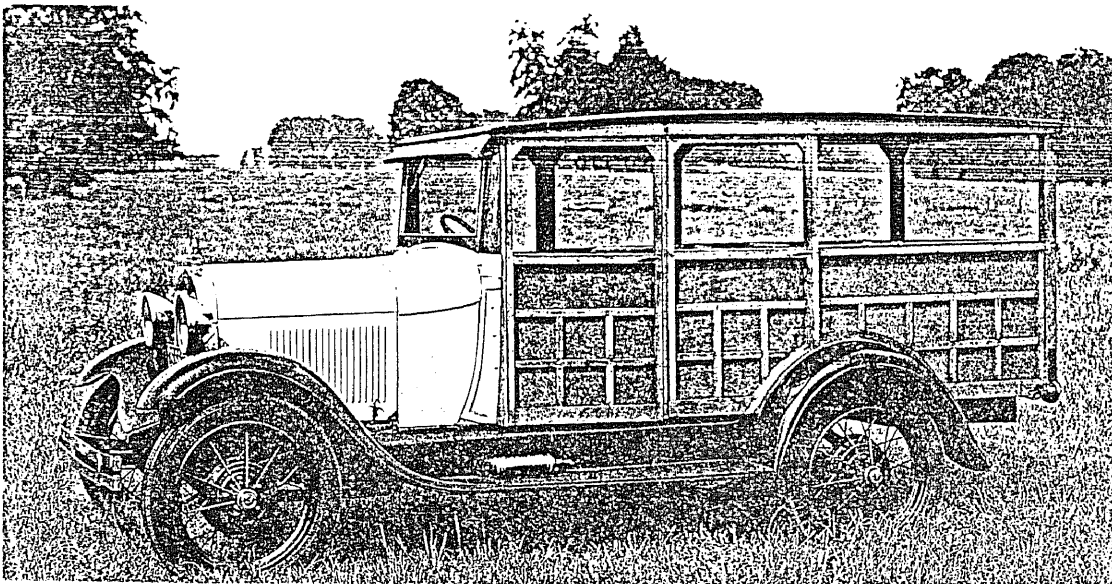

Ford  
Model A  
station wagon

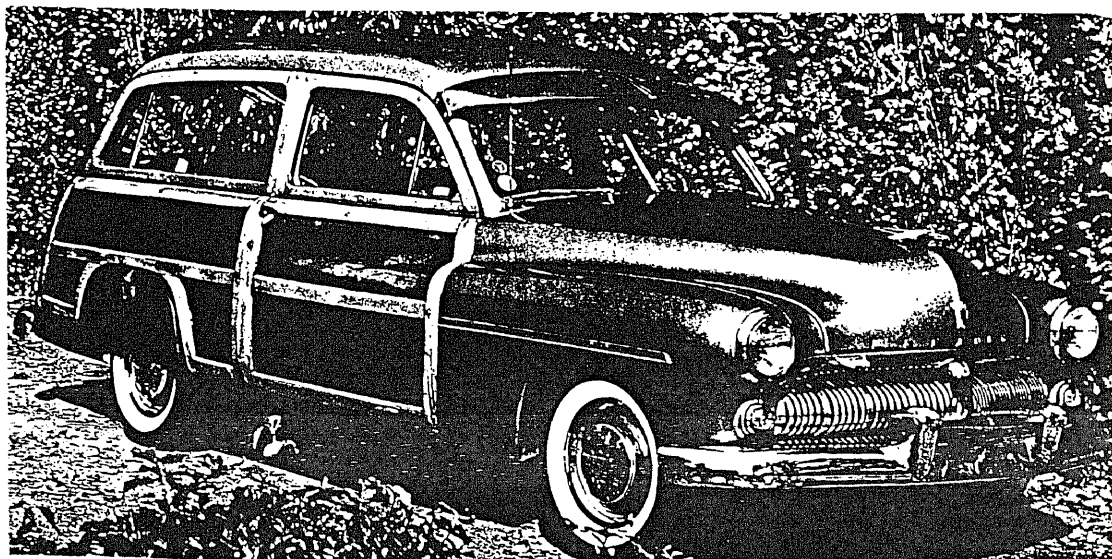

1956 Mercury  
station Wagon

enough to get away, badly camouflaged, not agile enough to climb trees and most importantly they don't have natural physical protection. Humans had to use their intelligence in order to choose from the beginning, suitable natural protection and, later on, to create protection on their own by constructing shelter, both homes, and armor. The Bronze Age witnessed the first basic armor . Bronze not only provided for the construction of efficient armour but also heralded the artistry of bronze metal working which lasts even to the present day.

The design of armor became, not only a question of protection, but also a method of visual recognition. It demanded extensive knowledge of human proportion and anatomy and became a means of emphasizing a warrior's strength. Symbolically armor draws importance from its function but the idea was carried far beyond the utilitarian level. For example, "Lorica segmenta", a very effective and easily recognizable armor of the Roman Legion, was the basis of identification in its day. From the 13th to the 17th century, craftsman managed to enclose the whole body in iron and it was a great step forward because they managed to enclose the body with metal plates, each with a unique shape, instead of the universal Roman armor. The later medieval armor was so designed that the various pieces were connected in a flexible system which protected the body and yet allowed motion. Medieval craftsmen learned how to make lightweight armour by reinforced it with tiny metal plates, creating thoughtful and artistically shaped wrinkles and a whole set of forms and shapes was developed to fit certain parts of the body. Each section of armor was custom designed, organically shaped and molded, but the result was not a pure copy of the human body. In addition to protection it created, by exaggerating muscles, breasts, legs, arms and head, a kind of supernatural image. Shiny iron, shaped organically and reflecting light, gave to the warrior an element of grandeur and strength. It presented warriors, not as they are but as they wanted to



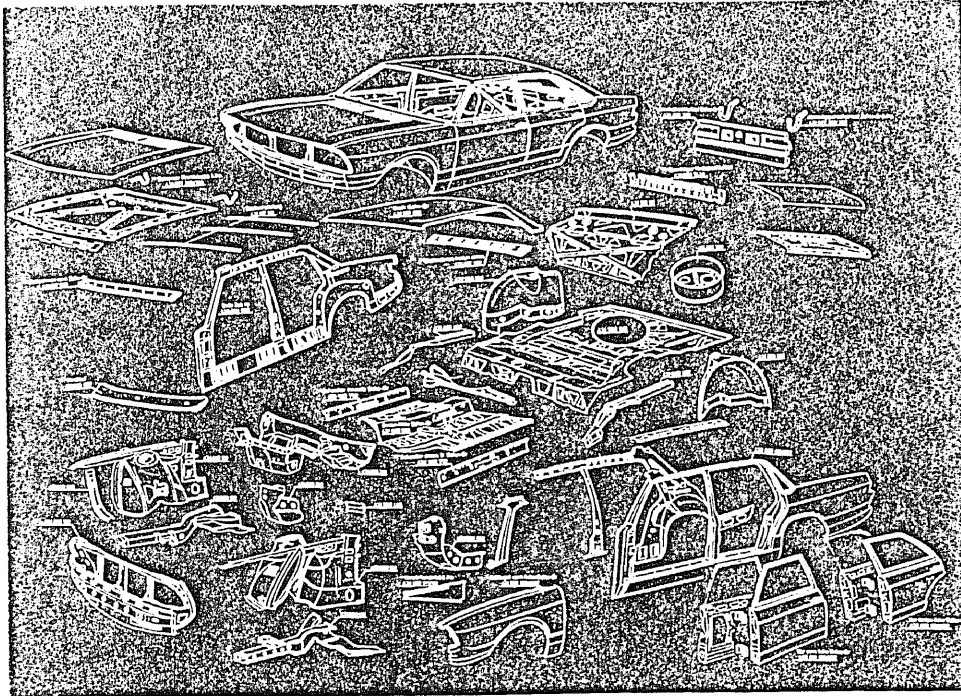
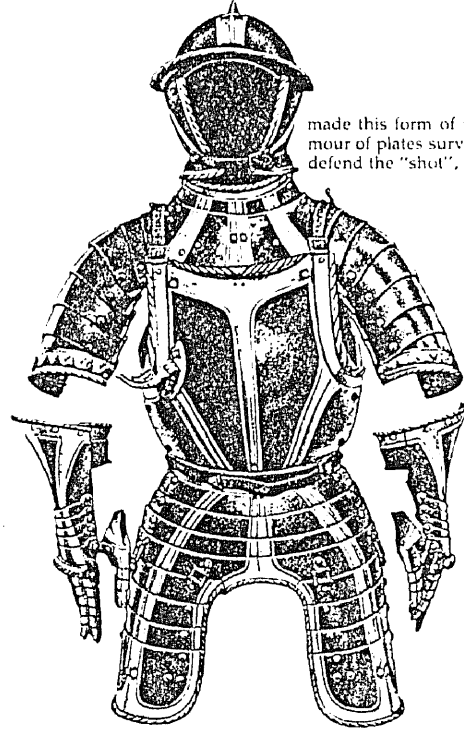
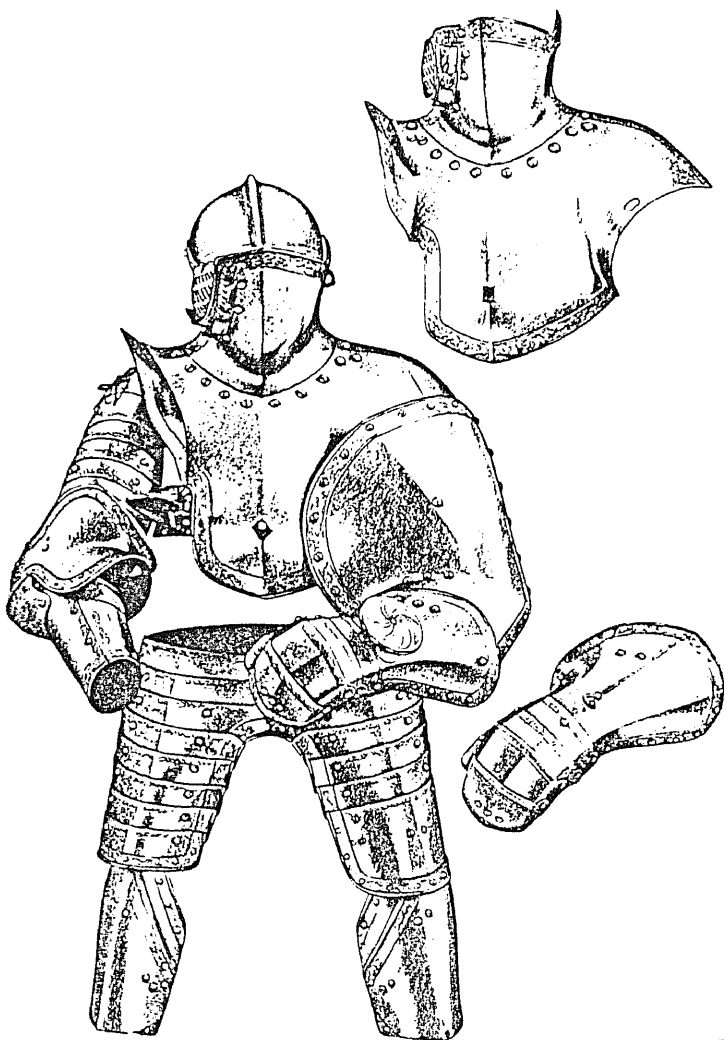
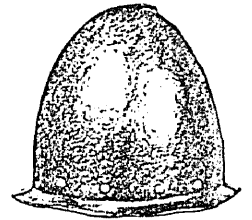

Fig 7-3 The separate pressings that go into making an Audi body shell.



made this form of protection obsolete. The true foot armour of plates survived with pikemen, often deployed to defend the "shot", for another century.



Above. The ubiquitous morion, again in a typical militia version with little skull in production, but essentially good protection.  
Below. A typical 17th-century "jack".

Armour for the standard infantryman was not of very high quality but some troops such as the Landsknechts, still wore distinctive armour. The "jack" and the morion were the usual form of "cheap" armour for the soldier.

Above. Black and white half-armor with burgonet, gorget, tassets and front- and backplate. The armour is roughly made by earlier standards and intended for the rank and file. German, c. 1570.



appear; as mechanical, unbreakable, untouchable creatures. Armor forged the way to an image of man as a mechanical object. Medieval craftsman succeeded, but only symbolically. Beneath the armor was an ordinary human body. The mistake they made was to attempt to generate a mechanical system by copying organic form.

Never-the-less, they mastered the technique of sheet metal plate, and the idea of a rigid, protective, structure surrounding the human body was oddly enough, to become part of the foundation for the concept of the automobile.

## ARCHITECTURE-AUTOMOBILE COMPARISON

### A. Basis for Comparison

Architecture and the automobile can be compared on many different levels. The abundance of archetypes that both share can be one point of comparison, similarities in compositional structure another. A contrast can be made between architecture and automobiles on the basis of technology and art and how that relationship influences both disciplines.

An ambiguous interaction between technical and aesthetic aspects has occurred throughout the different phases of the automobile's development. Although the technical aspect grows increasingly important, aesthetics has remained as a key but largely neglected issue. Even the direct invasion of technique into aesthetics through aerodynamics (with the help of computers and calculations) could not supersede primary aesthetics and for all the technological emphasis, human cares remained for several hundred years.

From the beginning Futurists admired a stripped down automobile left only with its mechanics. Although the automobile grew to be as important as they predicted, their aesthetic preferences did not win. The essential mechanics were covered up with various forms, shapes, textures and colors. This situation has persisted since the beginning of motoring.

How has the automobile resisted much of the pressure of the image of its own mechanics? The automobile is a very strong symbol, which symbolically plays a crucially important role for humankind. That strong symbolic value gives the automobile meaning and also helps make the technical aspect more acceptable in human terms.

The size of the automobile plays an important role in relation to human scale. Whether large or small automobiles are designed for seating with interior dimensions accommodating human dimensions. It functions as an extension of human organic functions. It serves more as a suit than a living space.

The automobiles' symbolic aspect is open to interpretation and adjustment, which gives it plenty of space for change but in today's world the automobile is almost entirely dependent on industrial constraints. Architecture is less resistant to individual interpretation because it involves a less sophisticated production complex. It is quite possible to design and build from scratch, or nearly so, where no one can make their own car in a similar manner.

Architectural leeway, allowing for imperfection and experimentation is an advantage that may or may not exist in both disciplines. It may give a good lead, or testing ground for exploration and comparative research. It may even encourage a probing into what is beyond the technical.

## B. Comparisons

On the level of direct compositional comparison, almost everything that Aalto designed can be compared with the automobile. Aalto's way of contrasting masses of the building is typical in his "House of Culture" built in 1955-58 in Helsinki. The auditorium and concert hall are rounded, irregular in shape and made of brick red. The administrative part is a pure rectangle, and dark grey in color. The two masses are united by a free standing shed which is straight forward and yet intriguing in form.

This composition of Aalto's can be compared with many automobiles produced in the first decade of the century. I choose Rochet Schneider, a French car built about 1906 because it demonstrates a clean design combined with excellent details. The Rochet cabin is curvilinear and the engine compartment is shaped like a boxy rectangle with a

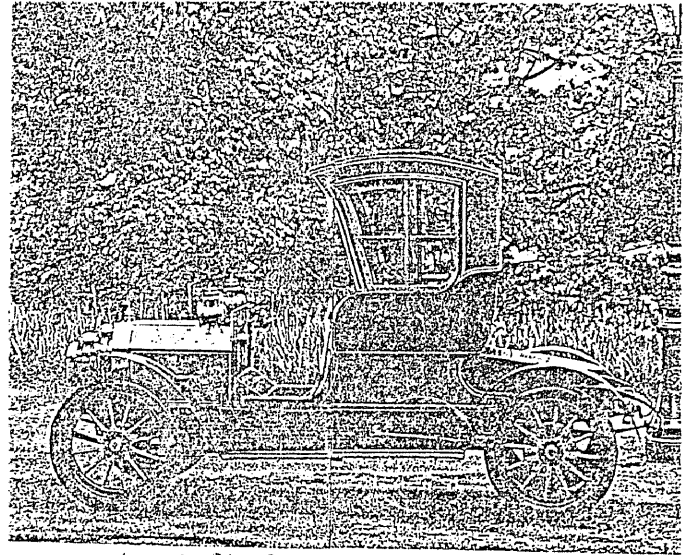
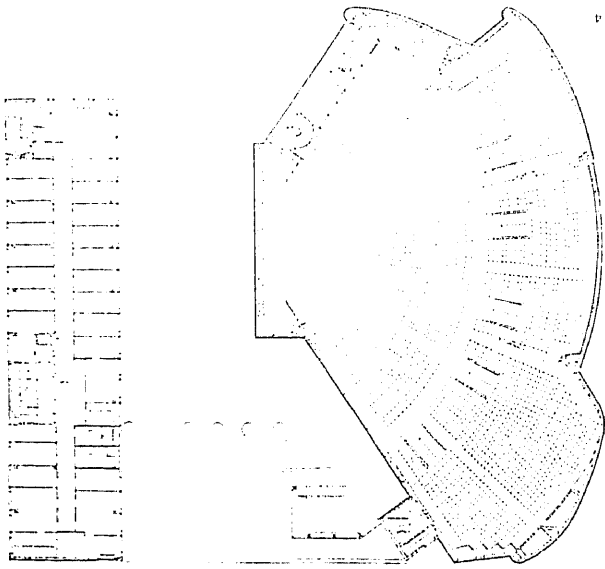

*photographs by Gianni Belli*

Alvar Aalto House of Culture Helsinki

Rochet Schneider

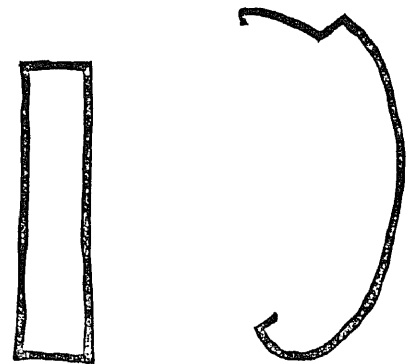
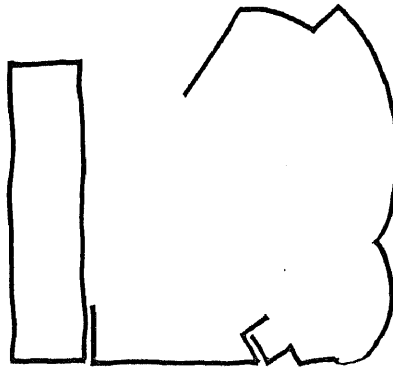
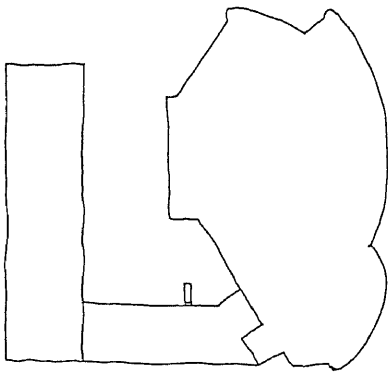
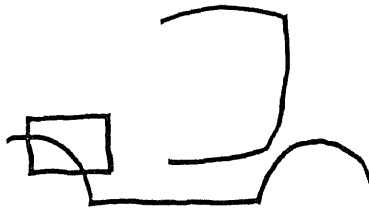
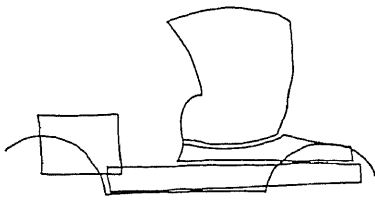

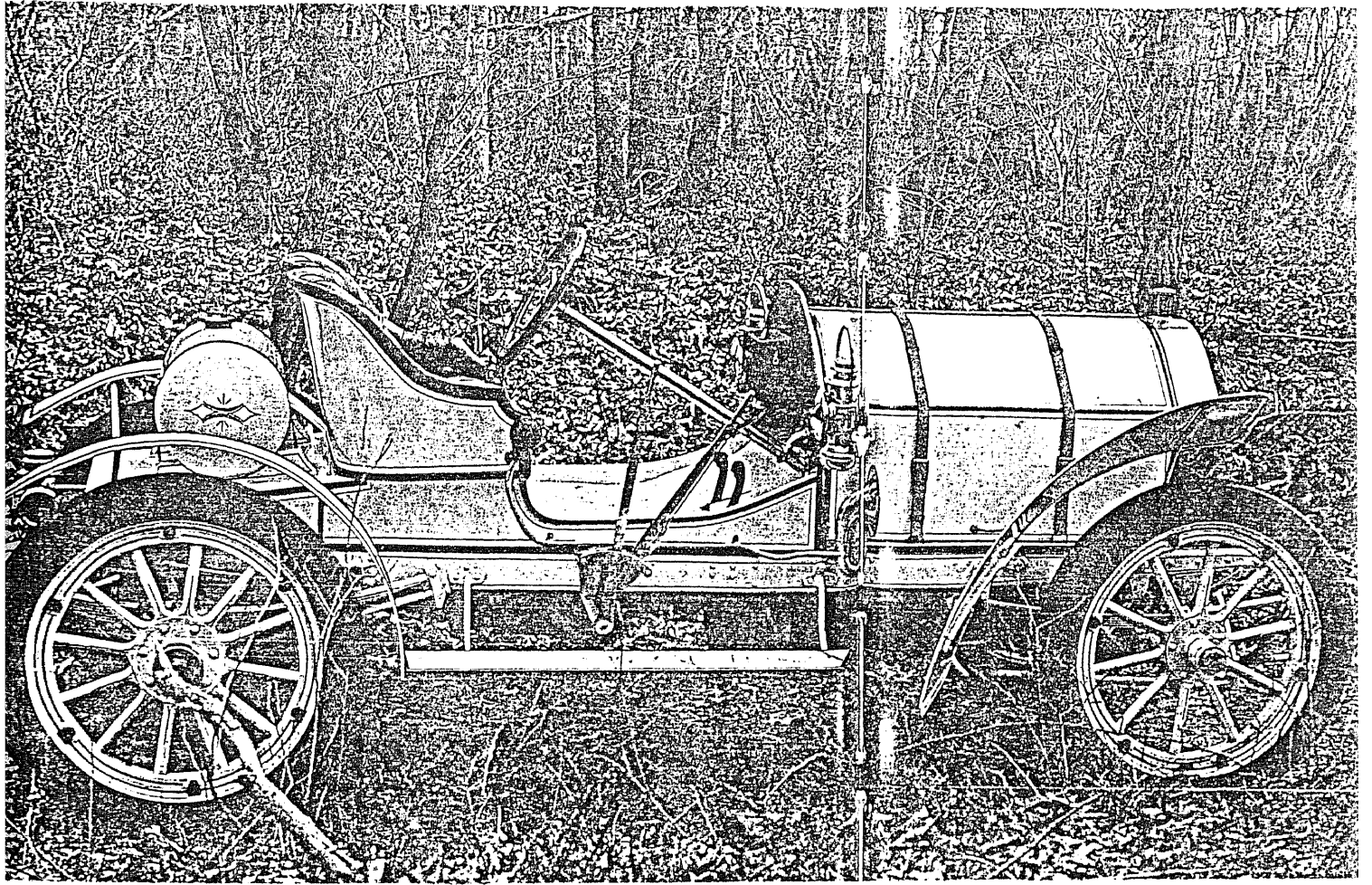

Yungo Finch

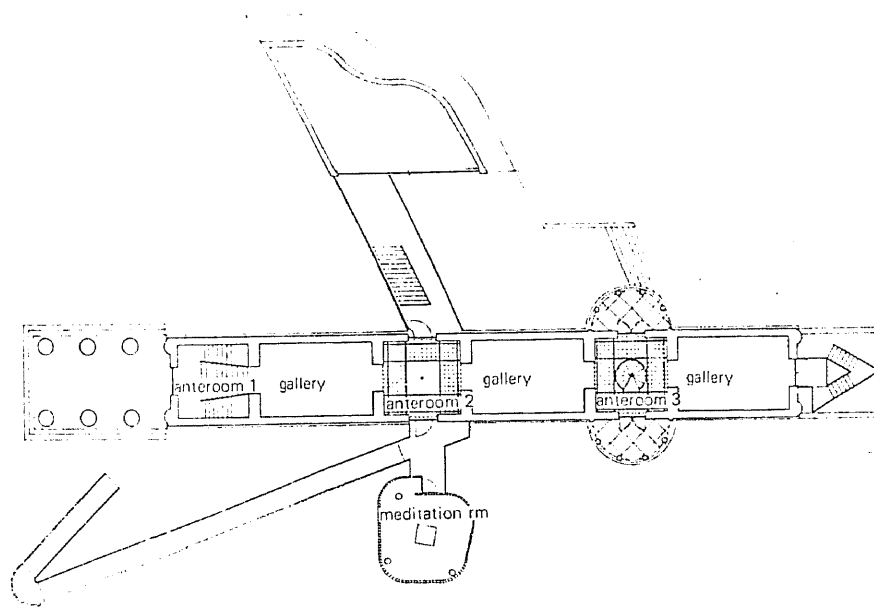

Okanoyama Graphic Art Museum

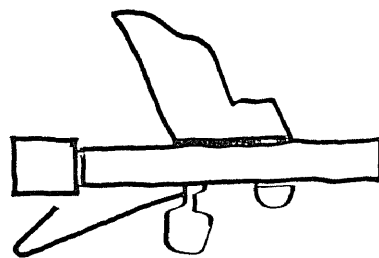
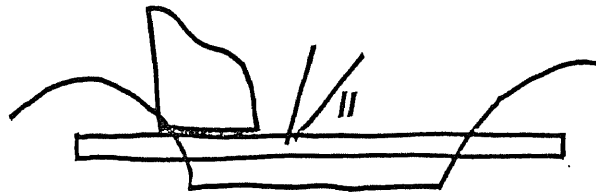
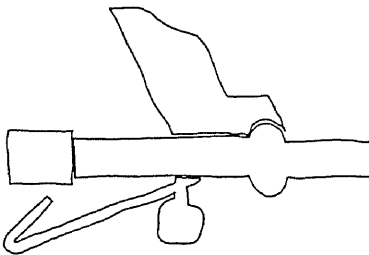
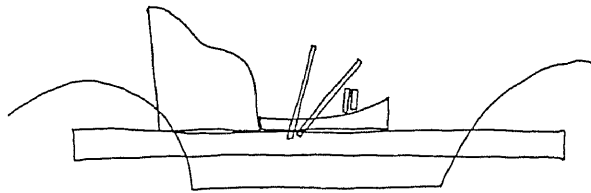
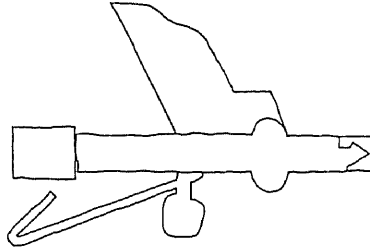
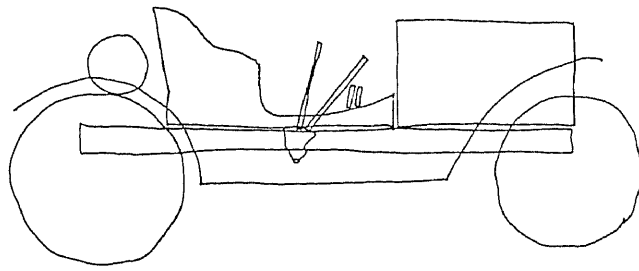

pitch roof top. The curvilinear cabin is sharply divided by the platform and vertical board, but it is also aesthetically united by the fenders making it one piece for both wheels.

The symbolic structure of both is similar to that of the Aalto concert hall, organic and noble, and correspond to the cabin in the design of the Rochet. For Aalto the administration building is a grey box, rigid and cold, for Rochet the engine is in the box. In both examples, noble, humane meaning is represented by curves and a rigid, technical presence is defined in terms of the rectilinear. The Finlandia music hall, Helsinki Studio House, Villa Mairea and the Finnish Pavilion at the World Exhibition in New York, 1938, are also fine examples of Aalto's method.

Building mass in Aalto's case is never sedate but never too dynamic. Broken lines and mild curves provide a simple rectangle on the interior to counterbalance a double curved ceiling within the dynamic space. (Juvaskyla museum)

An interesting comparison can be drawn between Pung's Finch and the Arata Isozaki Okanoyama Graphic Art Museum. The comparison in this case is more abstract than the previous one and the mechanical aspect is more strongly emphasized through ramps and stairways in the Museum and through hand levers on the Pungs. Curves are two-dimensional in both designs.

During the 1930's "streamlining produced considerable commotion. The term was used to describe form which speeds through air and fluids with least resistance and is based on the science and laws of hydrodynamics.

"...the motion of fluids takes place under two forms, laminar and turbulent flow. Laminar flow can be envisioned as a series of parallel layers in a moving fluid, each having its own velocity and direction without disturbances in its forward motion. Turbulent flow is characterized by eddy currents or vortices, a tumbling of the fluid caused by an alien form. This turbulence creates a partial vacuum behind the form, which retards its forward progress."(Bush, 1975, p.5)



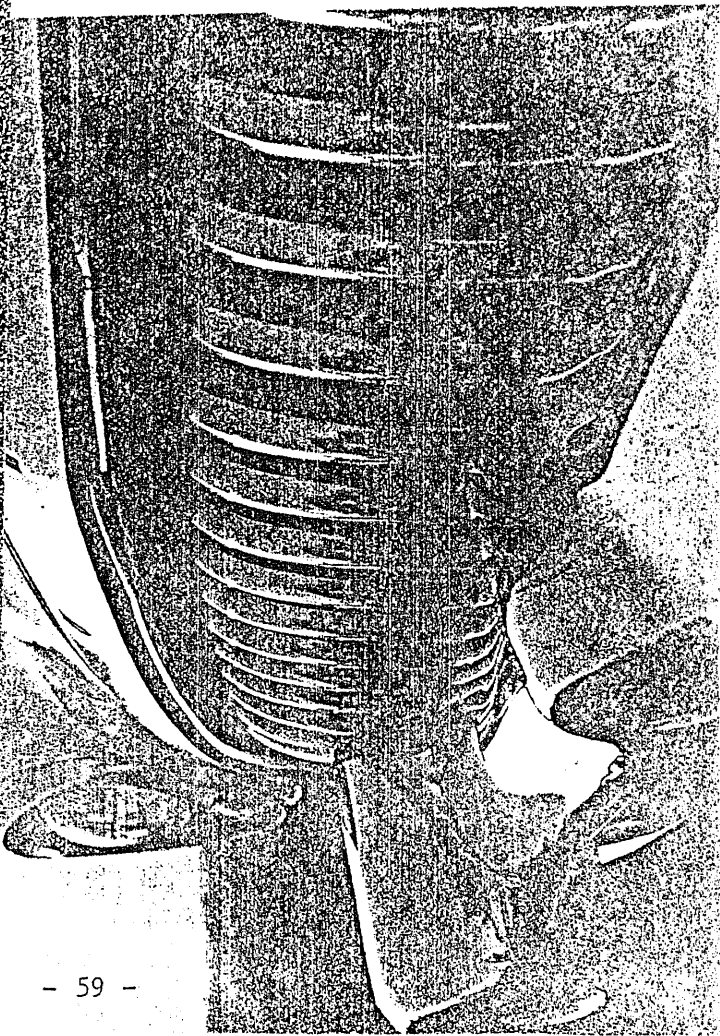
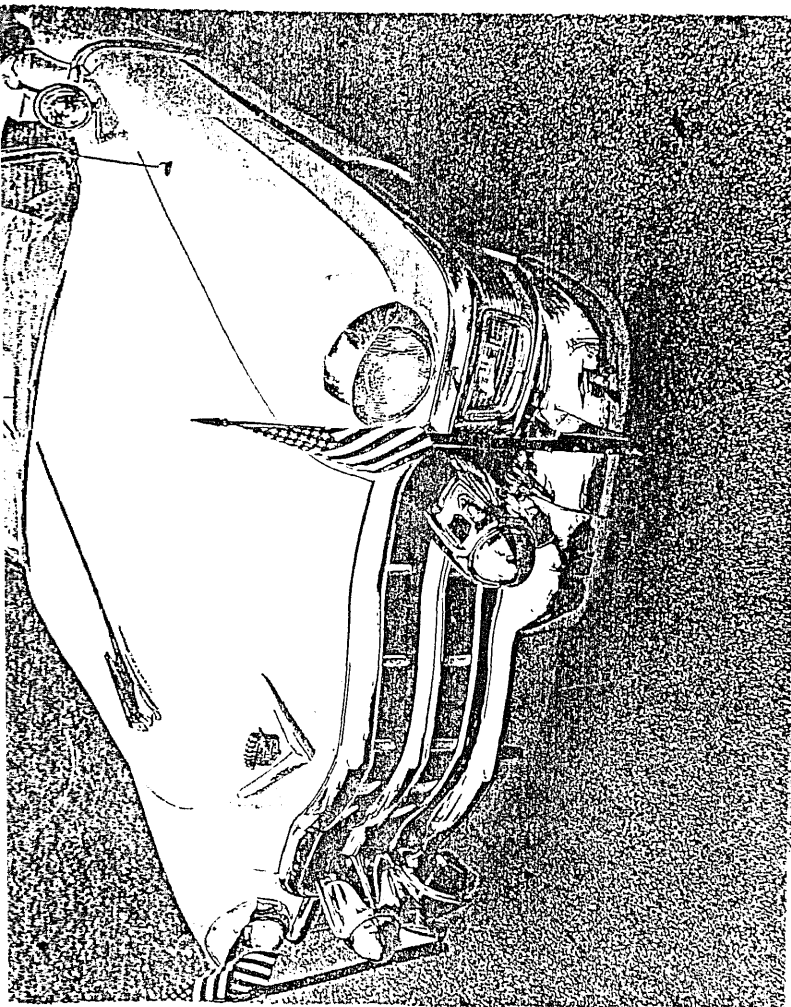
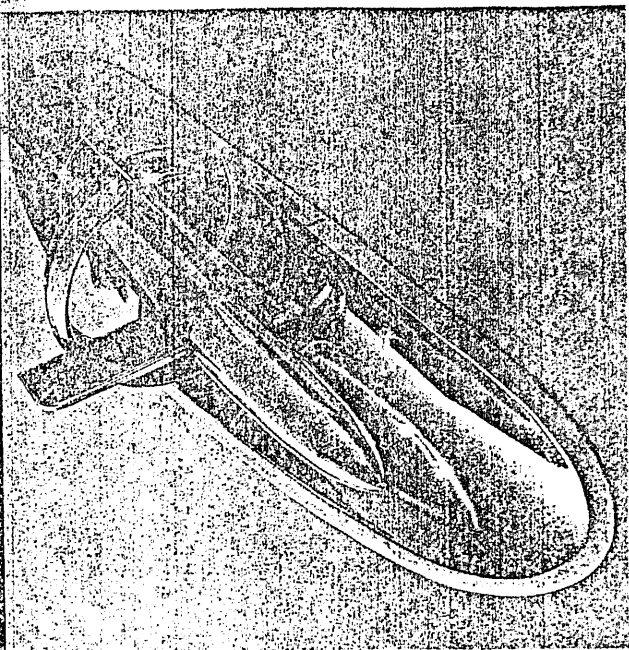
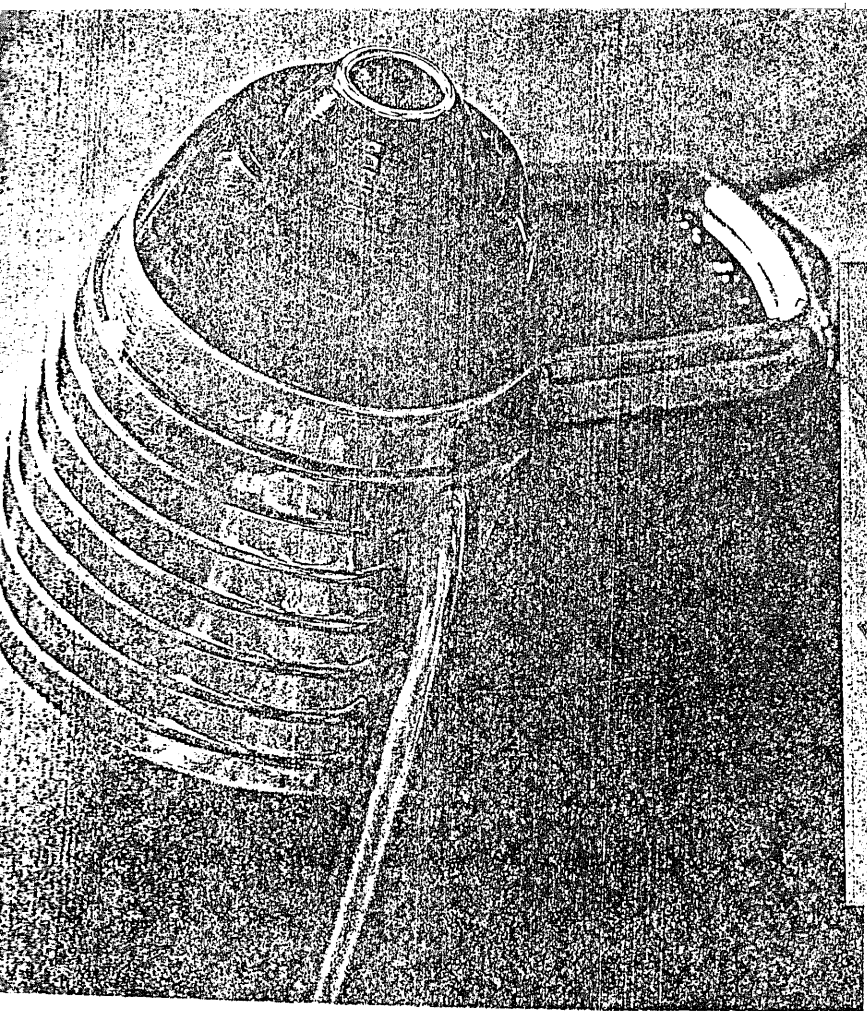

The rear style of the Alfa Romeo B.A.T. 8 was slightly altered and the Alfa Romeo badge incorporated below the central spine.

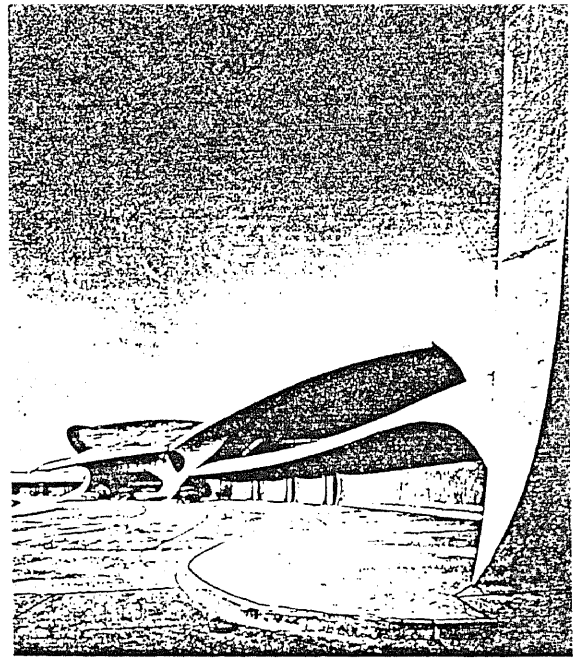
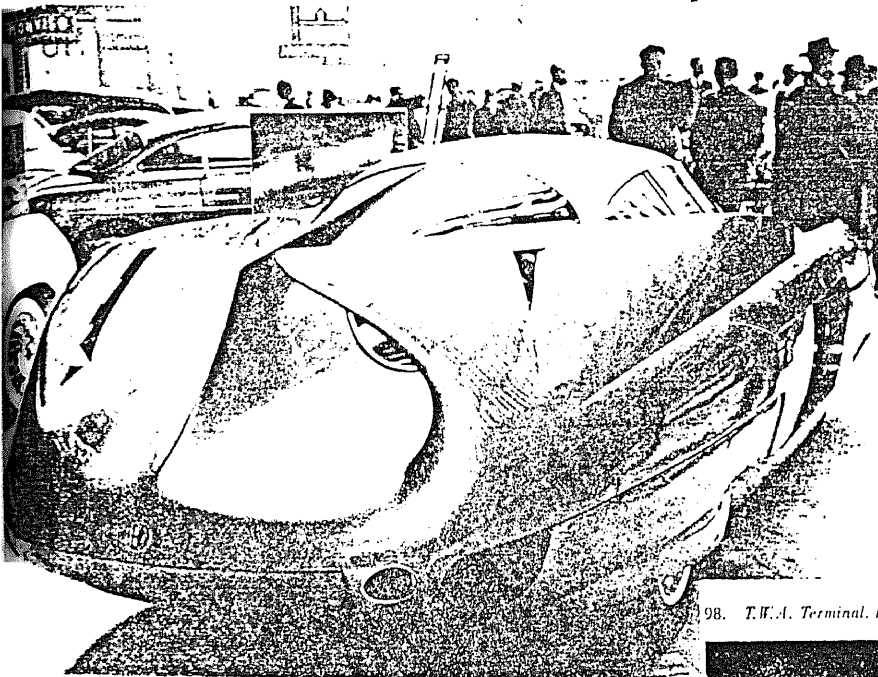

102. TWA Terminal Under construction. Exterior. (Photo: Ezra Stoller)

198. TWA Terminal. Interior. (Photo: Ezra Stoller)

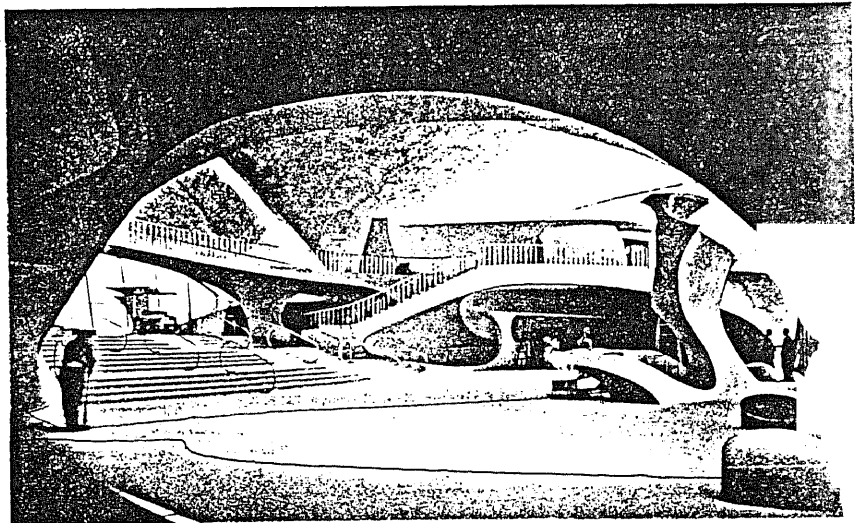

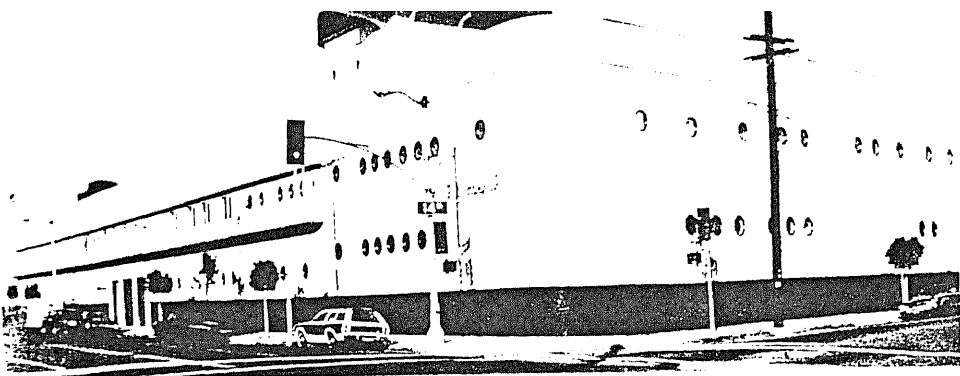

Streamlined images  
in architecture

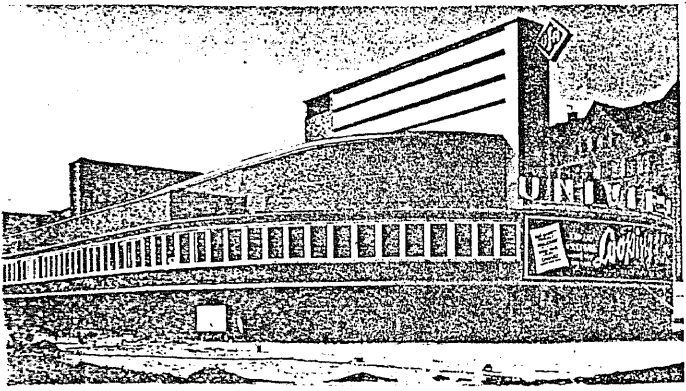
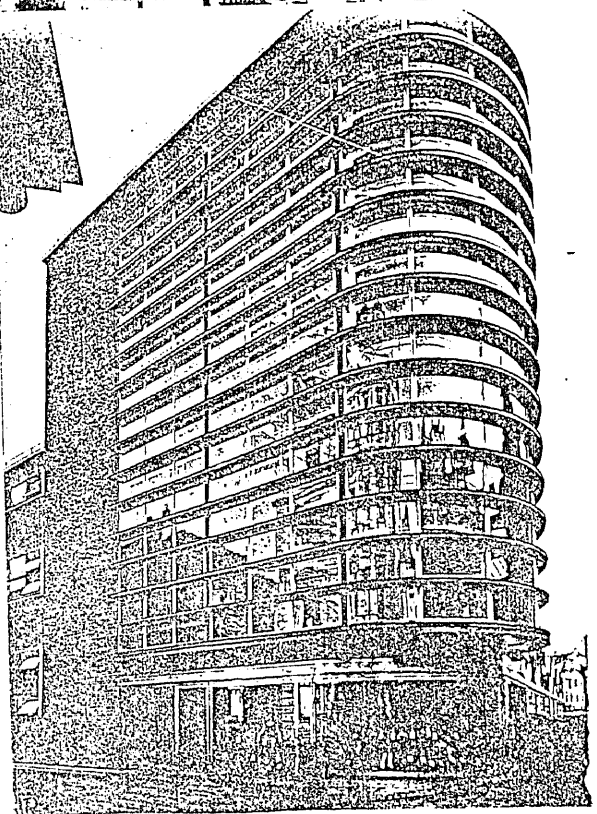
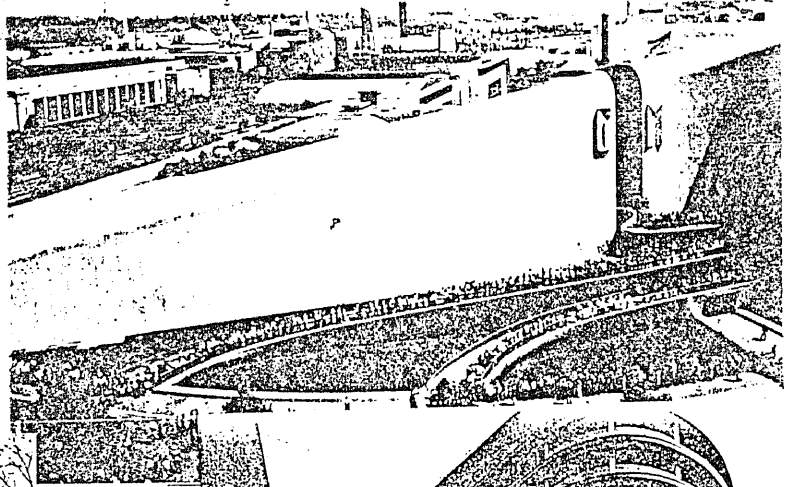
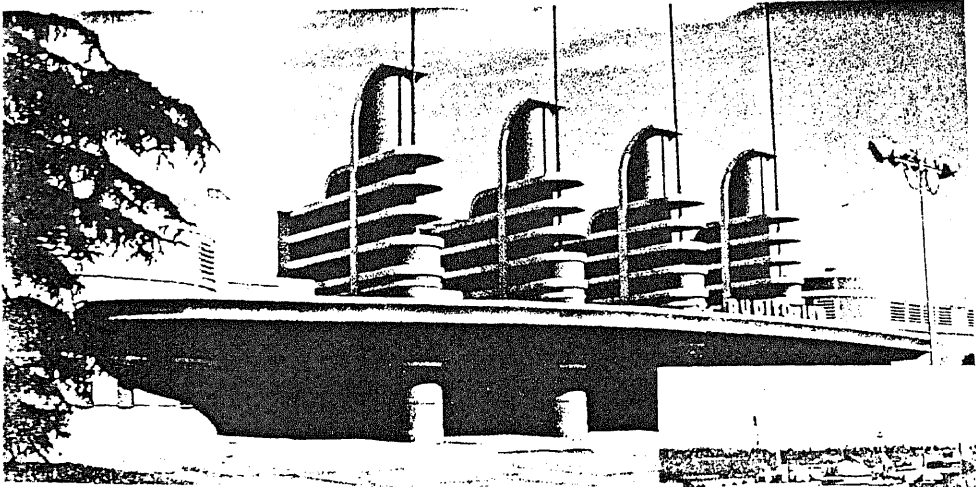

The idea of streamlining is to reduce turbulence and it became synonymous with saving time and energy. Forms that are produced on that principle are characterized by:

"...rounded edges, smooth surfaces and low horizontal profiles. All are simplified by the design principle of absorption, the merging of sub-form into another with transitional curves, and reductivism, the elimination of extraneous details." (Bush, 1975, p. 7)

Organic natural forms, like fish and birds, became a model for streamlining.

Streamlining affected everything from airplanes to coffee mugs. It was the only period in history in which architecture and automobiles shared the same philosophy of form.

Results were mixed in both areas, in architecture the results were not as significant as in automobile design but the automobile designed according to the principles of streamlining did not reach the market. Thirty years later streamlining became important again, but this time car form didn't become streamlined as initially intended. Instead, it adopted symbols of streamlining from airplanes; the very fast aerodynamic airplanes that had captured the original attention.

The jet airplane became the symbol of its time. The vision of that speed and agility inspired designers to transfer the image into automobile design. Fins, headlights, stoplights, decoration and details were shaped to fit the jet image and attached to car bodies. It was mostly a fantasy of intervention because overall design remained bulky and heavy, just as it had been in the 1930's. But jets were not the only influence. It was a period of post war enthusiasm and optimism. The slogan of "Peace and Prosperity" infected the era. The prosperity following the war brought the United States car industry into new vigor and enthusiasm. Demand for automobiles was greater than production capacity. During this period cars took on a significance in society which far outweighed the need. Wings were the ideal symbol of the era.

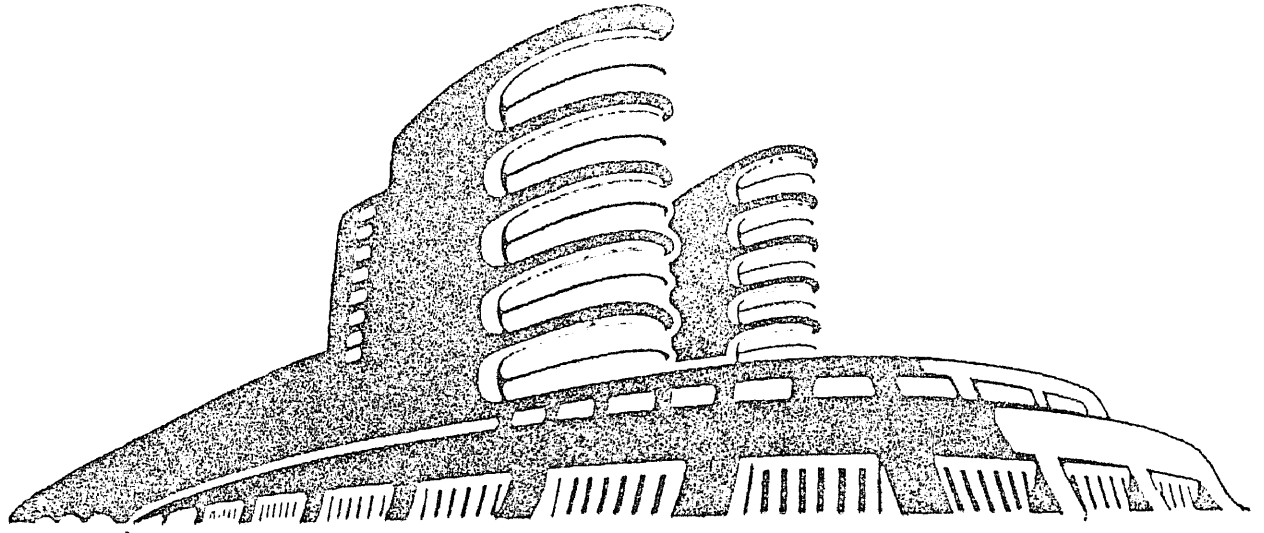

Factory for optical instruments

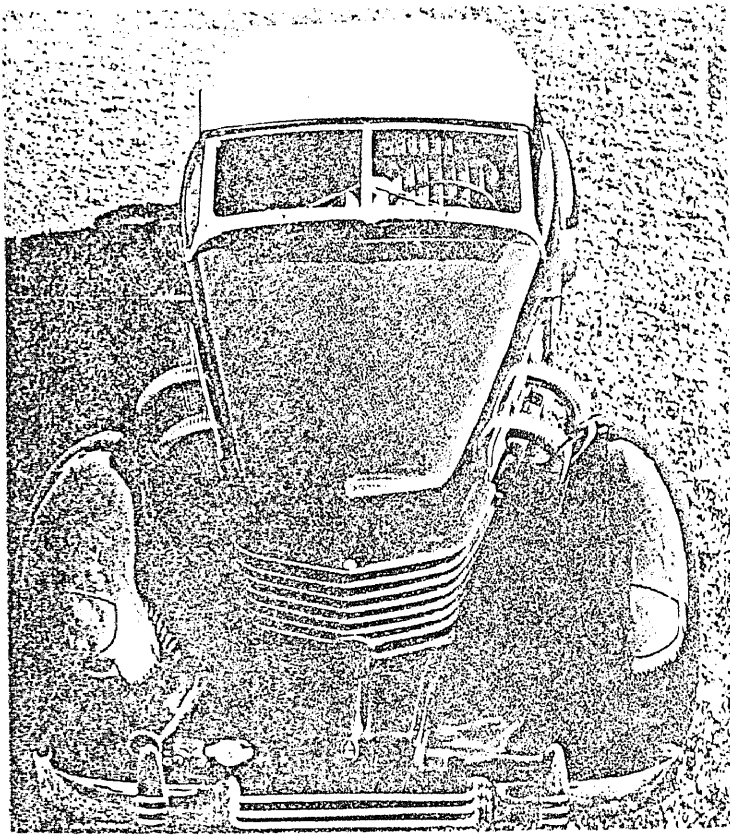

810 Cord from 1936

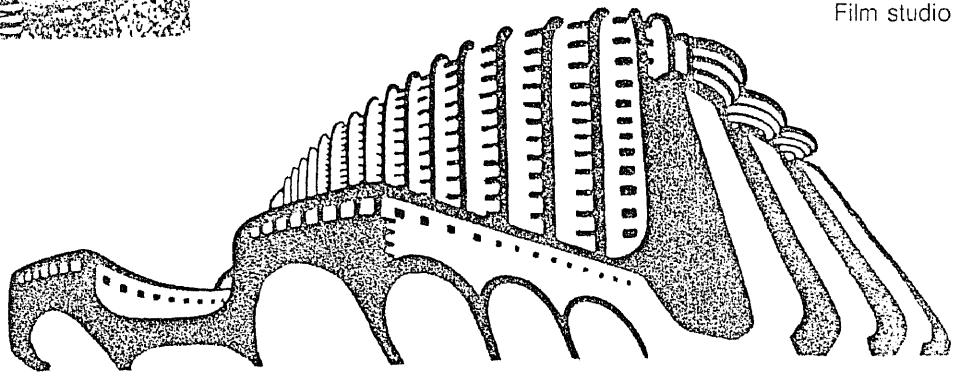
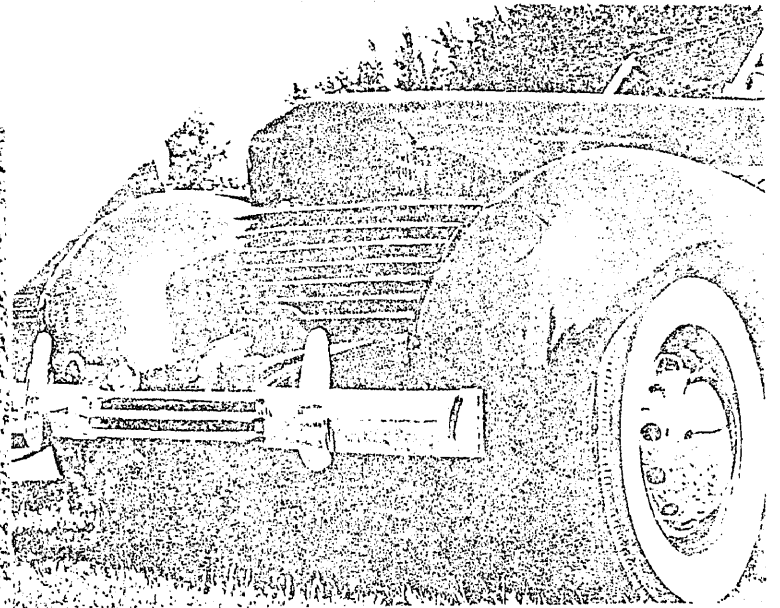

Film studio

Tail light and front hood decoration of the 1953 Oldsmobile 88, front hood and side chrome decoration on the 1953 Hudson Hornet, front hood chrome decoration on the 1953 Buick Skylark and fins of the 1959 Ford Skyliner are a few of many characteristic details typical of the excitement which prevailed, especially in the United States.

Symbolic, organic form has some parallels in architectural design. One fairly recent and outstanding examples is the TWA building at JFK airport designed in 1960 by Eero Saarinen. Inspired by the Utzons Sidney Opera House, Saarinen arrived at a wing like structure for the main building. It was the personification of a bird of flight and, ultimately, an airplane. Motion and dynamism were reinforced in many details on the exterior and interior. Saarinen basic inspiration is an actual bird rather than a machine for flying. Car designers use the opposite approach when they find inspiration in the machine for flying. Before the streamlined automobile was born, Mendelsohn brought to the architectural world dynamic sketches of factories, observatories, film studios, railway stations and airports.

His sketches were unrestricted images of an expressionist imagination and the forms he explored were organic and fresh. "The buildings of Mendelsohn are 'in motion' in ways that go beyond Neoplastic decompositional devices." (Zevi. 1976, p. 31) He evokes the building "...as one mass swollen with lava and jet plasma." Buildings are stretched along the longer axis, executed in the drawing with somewhat exaggerated perspective. Mendelsohn called that effect dynamism and although he did not have a consistent explanation it appears that he stressed the expression of internal forces. He explains his method in a description of his car:body factory:

" This sketch of a bodywork factory derives it's dynamism fully from the forces in it's steel construction. The row of gantries, indicated as lattice trusses, draws the forms together sharply at the highest level, while at the same time the corner blocks the nod forward. That is, the loads transmitted through the gantries are absorbed by the tie-girder structures in the corner-towers."

After the war Mendelsohn tried to work as a member of the Amsterdam school but he found no future in their trend. He wrote:

"Certainly the primary element is function, but function without sensibility remains mere construction. More than ever I stand by my program of reconciliation... Rotterdam will pursue (Oud) the way of pure construction with the deathly chill in its veins, and Amsterdam will be destroyed by the fire of its own dynamics. Function plus dynamics is the challenge."

In 1936 G. Buehrig designed the 810 Cord which resembles in some ways Mendelsohn's form of dynamism, especially in its front portion. The grill that extends on both sides has a horizontal division with subtle architectonic values.

Another example of expressionist architecture can be seen in the work of Michael De Klerk, an important figure of the Amsterdam school. His simple and pure forms, combined with elements filled with joy and imagination brought to his buildings a sense of lyricism. In his buildings imagination doesn't stop but continues over and over again to surprise and puzzle. When there are no plastic elements at work he begins to play with windows. The monochromatic effect adds a sense of elegance and peaceful strength. His buildings are part of the dream of Amsterdam, its ocean going past; but they are ships caught on the ground. Roots of that dream are in Dutch history of a time when they were superb navigators and ship builders, but while the buildings are spiritually connected with history their expression is abstract, sometimes mechanical and futuristic. It seems that they are ready to take off in another dream. De Klerk's buildings can be compared with some recent futuristic design proposals.

The automobile's futuristic proposal is trying to catch today's cosmic dreams, pretending they can fly while firmly standing on the ground. The image of flying is portrayed by elements usually associated with space ships. For example Giugiaro's "Aztec" design has buttons and instruments on the exterior panels which brings to mind

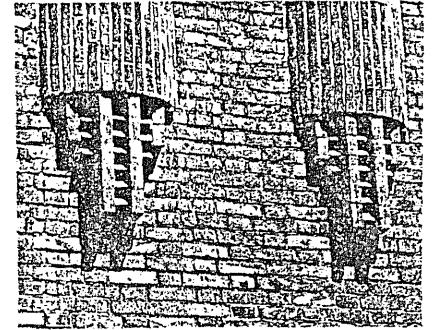
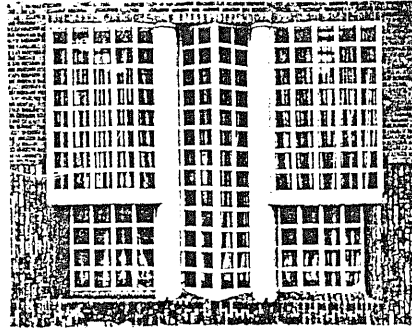
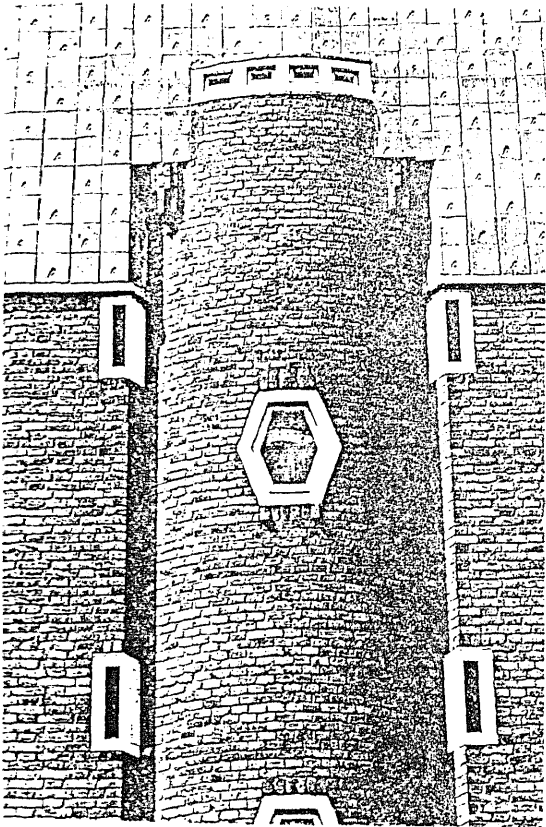

**Roadster-Studie  
von Giugiaro**

man ihn für Mister Future auf dem Weg nach Metropolis gebaut

Images of Michael De Klerk's architecture

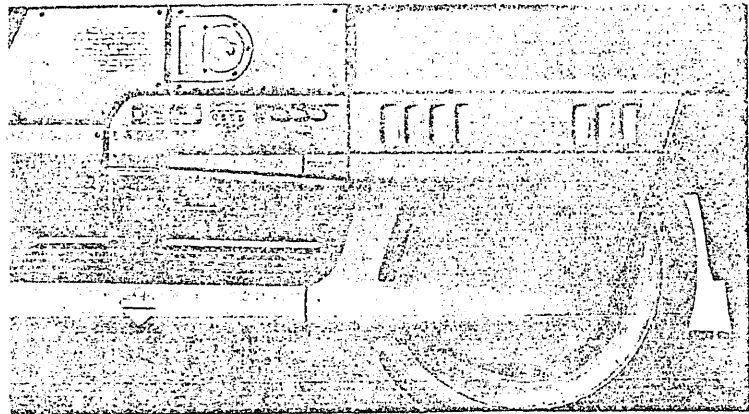
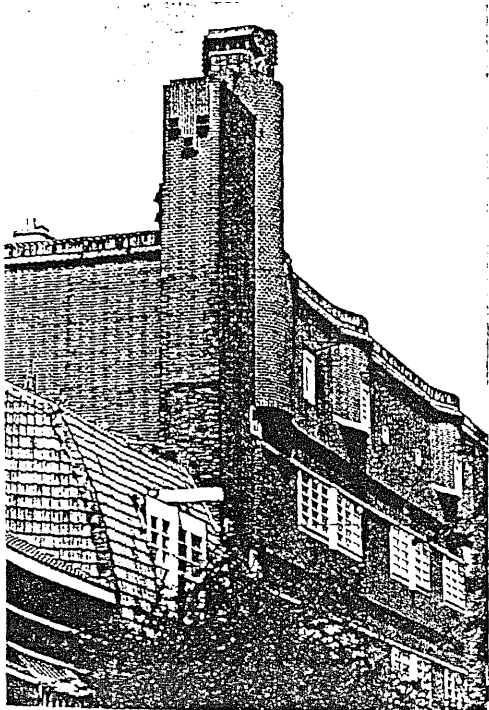
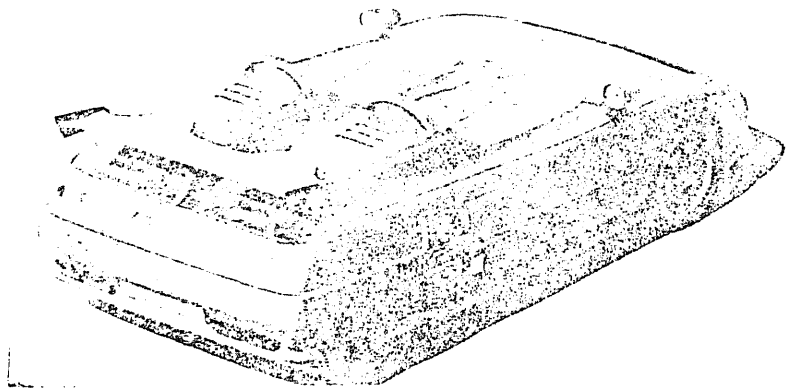

Fotos: H.D. Scuteri

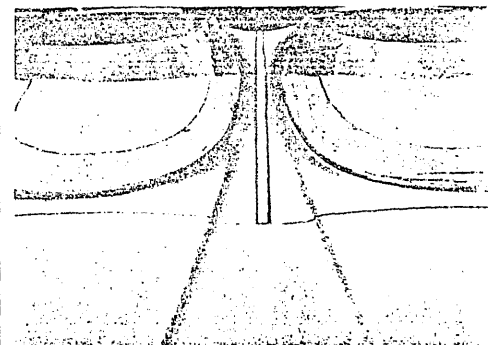
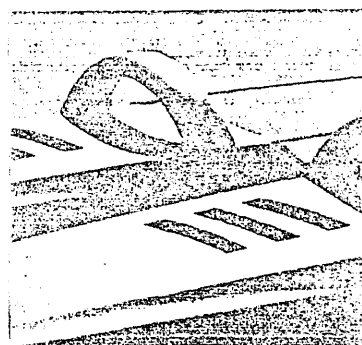

AZTEK



science fiction and its portrayal of space ships with complex exteriors covered with buttons and instruments. But space ships sail through a vacuum and they don't have to fight air resistance. The rationale of using the same elements used for car design as in space ships is trivial, the space dream is what counts. Although automobiles don't have the ground their spirit is ready to sail.

Giugiaro's "Aztek" aesthetically resembles the image of a machine. We don't see fins and wings as the late fifties. This is a different time, but the instruments of the panels modestly suggests a machine aesthetic.

It is strange that the automobile never acquired the look of a machine except in its formative years when mechanical magic was an equal participant in the overall look. Since that time the mechanics had equal participant in making the overall look. Since that time the mechanics have been, for the most part, covered up. For this reason Giugiaro's design appears as something daring and new.

Quite contrary to the automobile, buildings have persistently tried in this century to project the image and look of the machine. Machine aesthetics was a major inspiration for many leaders of the modern movement. The way they understood the machine through efficiency and function. Speaking in terms of geometry and aesthetics, straight lines and simple geometric forms were adopted as a symbol of efficiency. For Zevi that approach led to the International Style, a modern version of the Beaux Arts tradition.

Although the principle of efficiency and repetition was understood well enough, something obviously went wrong in the transfer of that understanding to architecture. The architecture of machines was never meant to be a geometry of straight lines, it is bizarre but its form and structure is organic.

Despite the failure of the International Style, machines remained a source of inspiration for architects. For the young Japanese architect Shin Takamatsu, machines

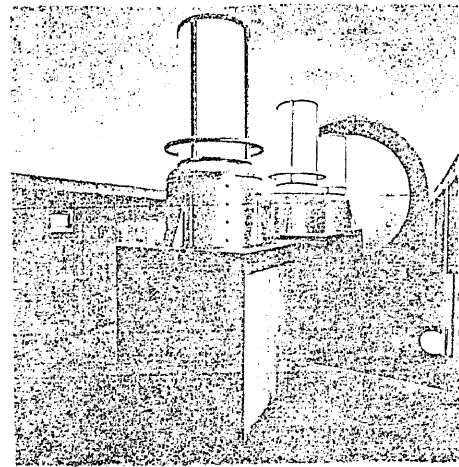
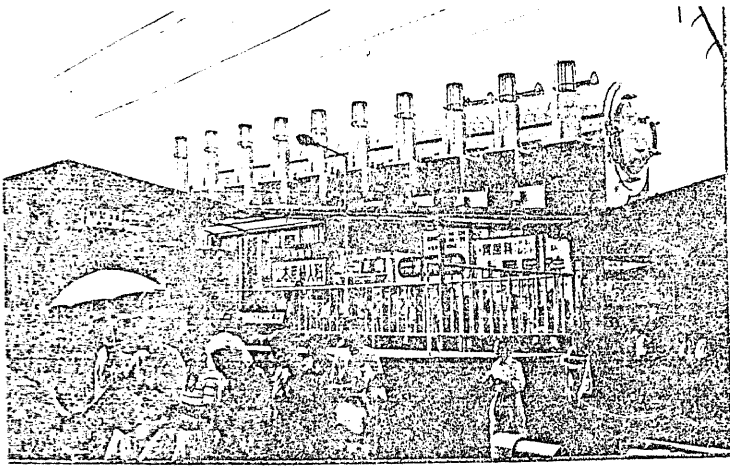

Shin Takamatsu's dental clinics

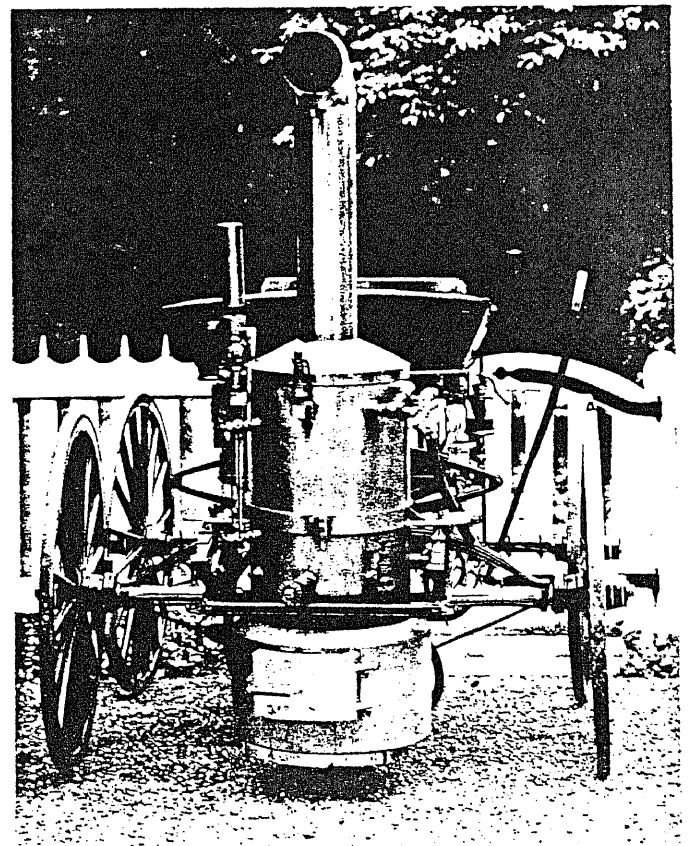
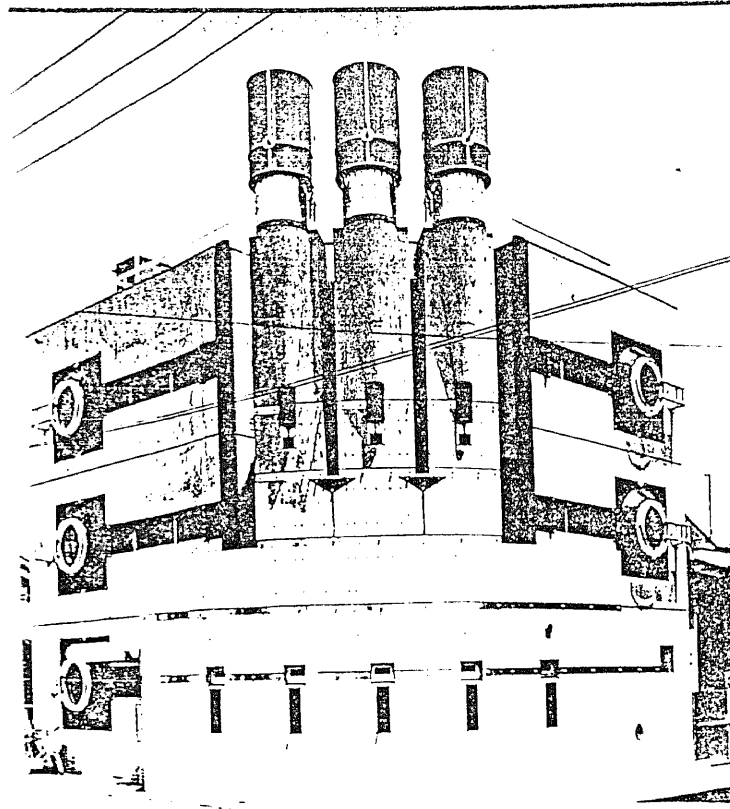

Taylor - 1867  
Canada's first horseless carriage

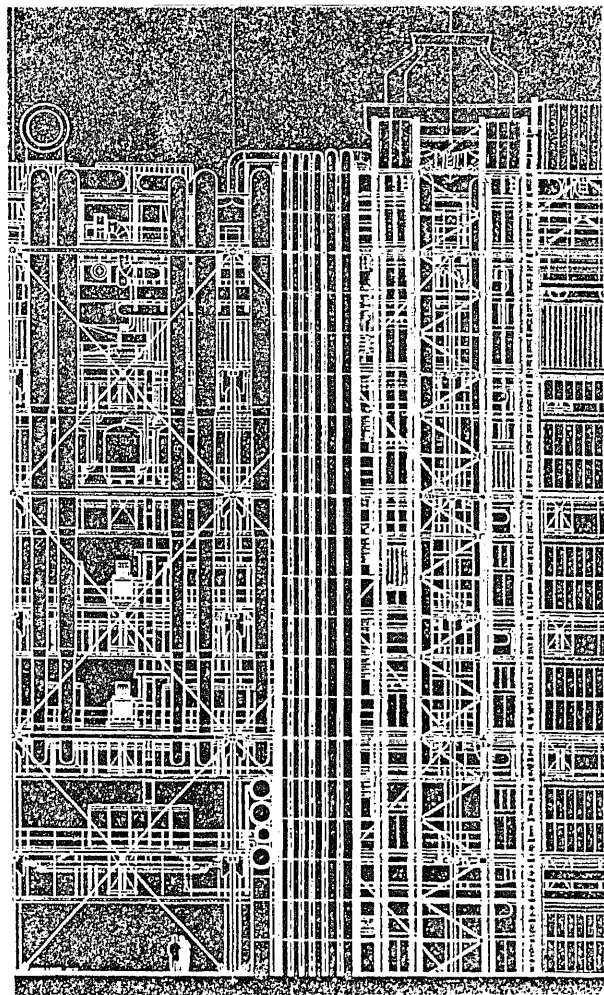

Pompidou Centre

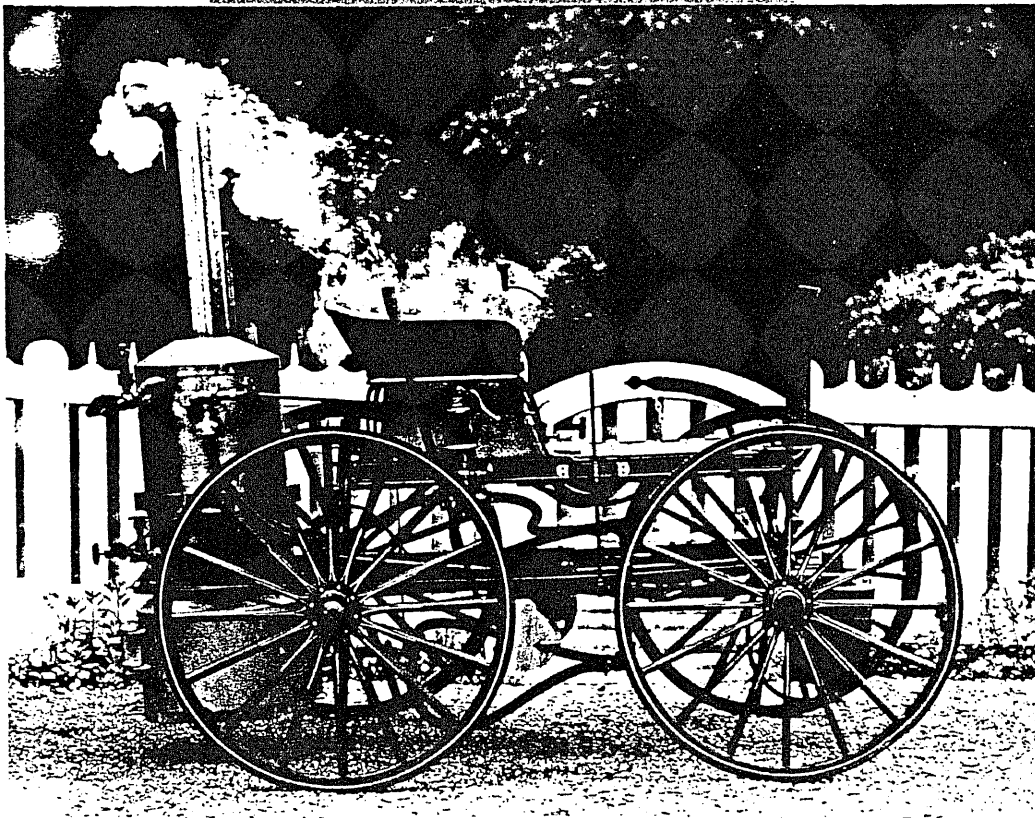

Taylor - 1867  
Canada's first horseless carriage

are also a source of inspiration but he doesn't subvert the image as a function or philosophy of the machine. His approach is much more direct, his buildings actually are meant to look like machines. They are not the machines that we know, they are dream machines. A noisy, heavy, steaming but very existing dream that makes his architecture. In Takamatsu's buildings details are mechanized to the extreme with doors, windows and chimneys sealing the building rather than opening it in order to enhance the inner tension and energy that is ready to explode. Steel and concrete are the principal materials. Concrete is treated in a pure Japanese fashion, perfectly crafted with precise edges and a clean surface having little round holes. Machine aesthetics is, for Takamatsu, merely the reflection of content.

Piano-Roger's Pompidou Centre stirred up the public with its industrial, appliance approach. Piano explained the building as

"...not a triumphant building. In fact I would say it displays a certain sense of humor: one might even call it a joke. Far from being a triumph of technology, the Beaubourgh is not even an industrial building. If anything, it is a gigantic piece of craftsmanship, made by hand, bit by bit, a great prototype... We designed everything right down to the smallest screw." ( )

Should Beaubourgh become the subject of imitation for architects wishing to express technique? Pianos responds:

"That is the most negative side of it... The fact that it is becoming a functional or even a formal architectural model is tragic and absurd. If anything is worth copying, it is design procedure, the scientific approach, the technical research..." (?)

Frank Gehry offers a different approach, especially in his family houses. His sculptural use of different cheap unorthodox materials, in strange new ways, is possibly an opening into new frontiers. His metal fences, chains and wavy sheet metal are pure

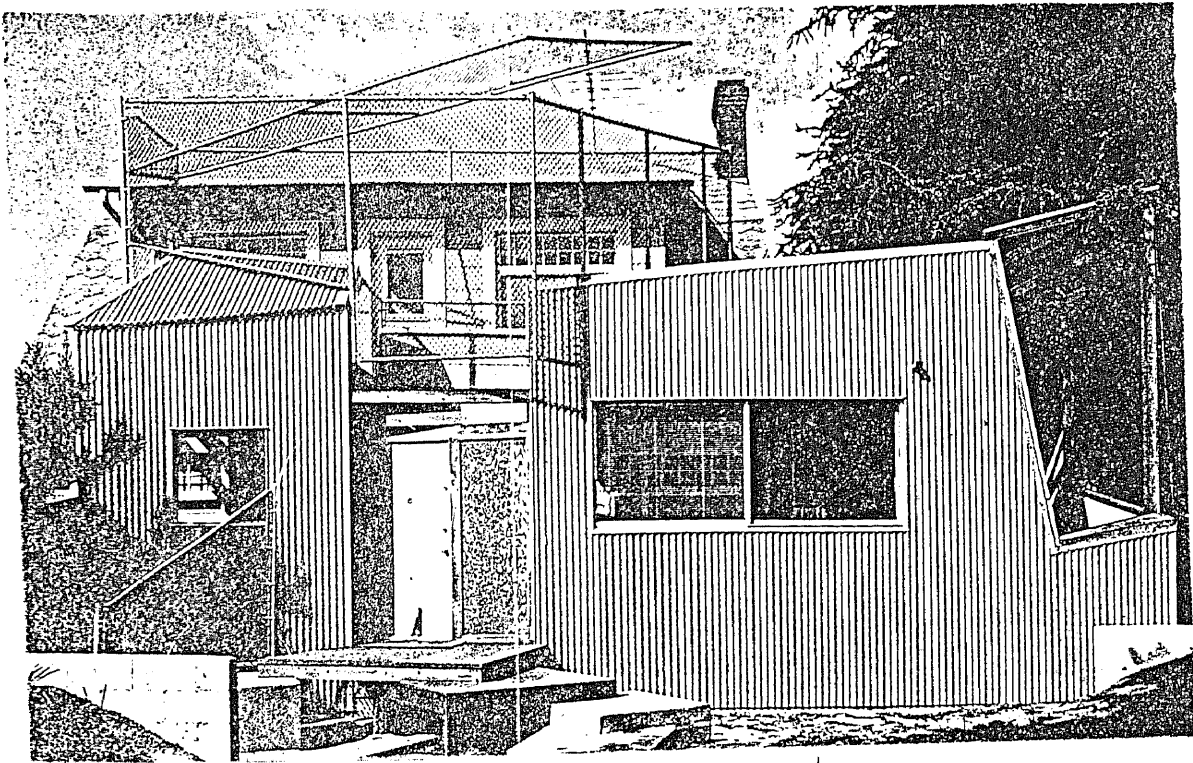

Frank Gehry's house

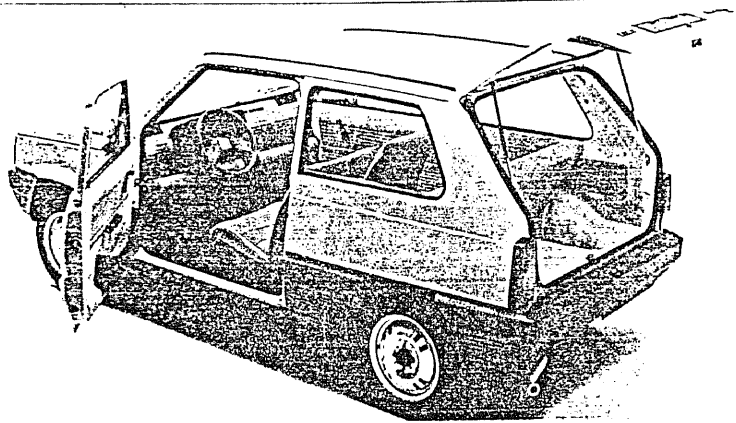
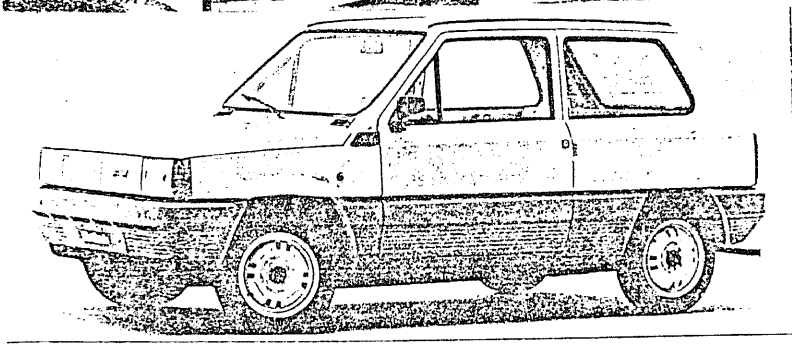

FIAT Panda

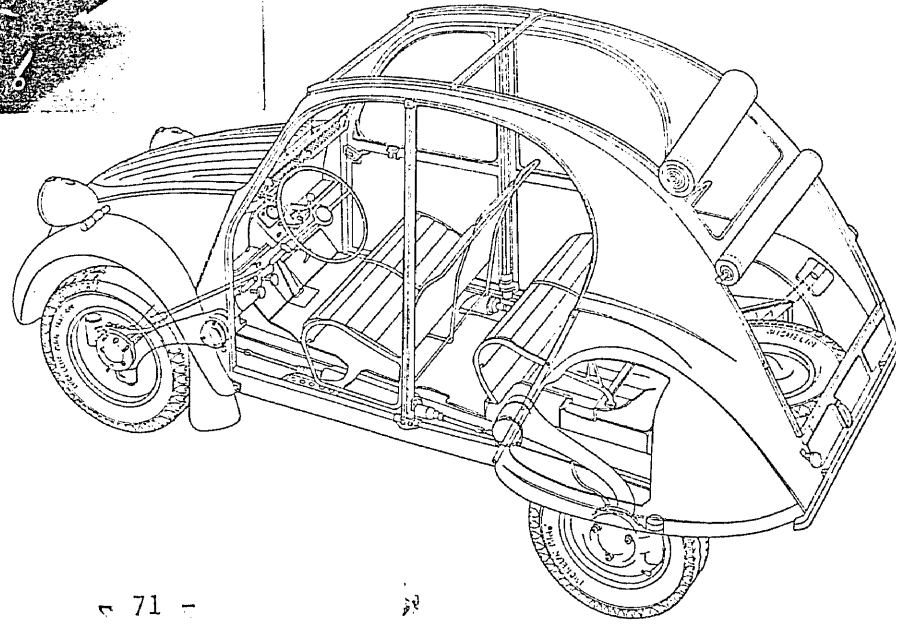
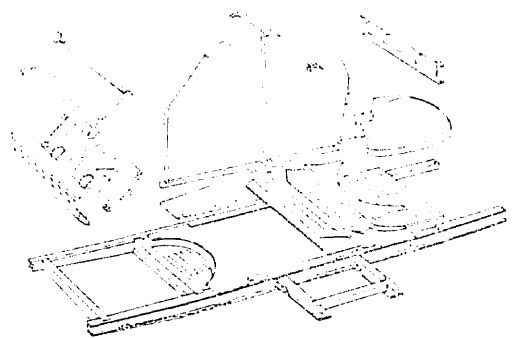

Citroen 2CV4

technical output, not used according to intended applications. They are also the depersonalized technical output known to us for years as simple, plain and ugly. In the context of design as proposed by Gehry they become miraculously transformed. Gehry also touches the frontier beyond technology. How long, after all, can technology continue to fascinate us?

The automobile is in the same situation with technical fascination and the accompanying dilemma. There are only a few attempts in history to produce an automobile based on the anti-principles of ordinary and ugly. One almost perfect example that matches the principle and probably Gehry's convictions, is the Citroen 2CV4, designed in the 1930's which appeared on the market in 1948. It is still in production. Simplicity and a practical spirit are the key features of that car. Body elements can be made with the minimum of press tools because there are very few curved panels. The door and hood use interlocking flanges instead of hinges and seats are spanned canvas on a metal frame, which are quickly detachable. It is a very roomy car, with a removable roof top, a long trunk, innovative comfortable suspension and front wheel drive. The first model had hand-operated wipers.

In the late fifties Renault presented its version of the same concept, Renault 4. Renault is more fashionable and closer to the "main stream". In the late seventies Giugiaro tried to recapture part of that spirit in FIAT Panda. It is a boxy little car mostly sheathed in very simple panels and simplicity maintained throughout whole car, but the aesthetics of ugliness and charm were consciously pursued. He treated ugliness by using criteria of beauty, controlling every line rigorously. Panda is a cute car but that's all, it lacks the free spirit that reaches from within.

No one has since tried to produce such an anti-symbol of the automobile. In the 1930's 2CV4 was the anti-establishment automobile of its day and it remains to the present day. The vitality of concept kept the car alive despite the effort of the manufactures to cease production. Appreciation by the public shows that the most advanced technology is not all that matters.

## VII. ARCHITECTS AS CAR DESIGNERS

In 1935 The French Society of Automobile Engineers announced a contest for the design of an automobile and Le Corbusier's submission was one among 102 entries. The purpose of the contest was to propose a peoples car for the future. It was the only contest of it's kind ever held. The motif behind the contest was relatively simple, French society and economy felt a desperate need for social and welfare reforms. With higher wages, shorter working hours and paid vacations large numbers of people could afford to have a car. But, cars were a great luxury in France at that time and a small, serviceable, low-cost car was seen as an important potential contribution. Regulations for the contest were spelled out with economy as the main goal. Design specifications were:

Type:	Sedan, very comfortable, two seats
Selling price:	8000 franc's (\$528), based on the average
Production:	twenty cars per day
Top speed:	Minimum of 75kmh (46,5 mph)
Fuel consumption:	5 liters per 100 km (%^mpg)
Acceleration:	Fully loaded, in top gear, on level, not less than 1.5/sec. at 22.5mph
Operating costs:	300 franc's per month of 1000 km traveled (approx.. 3.3 cents per mile)
Luggage capacity:	Two sheltered locations each able to hold a suitcase weighing 20 kg (approx. 45 pounds) and measuring 20/40/71 (approx. 8/16/28 inches)

It is important to point out that goals of the contest were specific to the French market. For example target price of \$528, one half the price of the average for the least expensive French car, was \$33 more expensive than a brand new Ford V8 coupe in the United States, even the Fiat Topolino introduced in 1936 was cheaper.



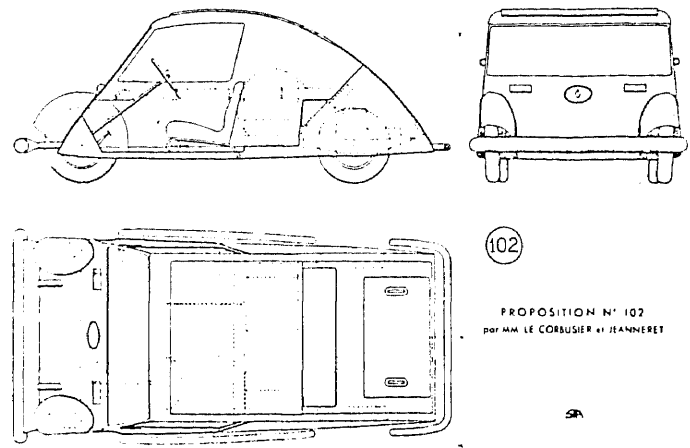
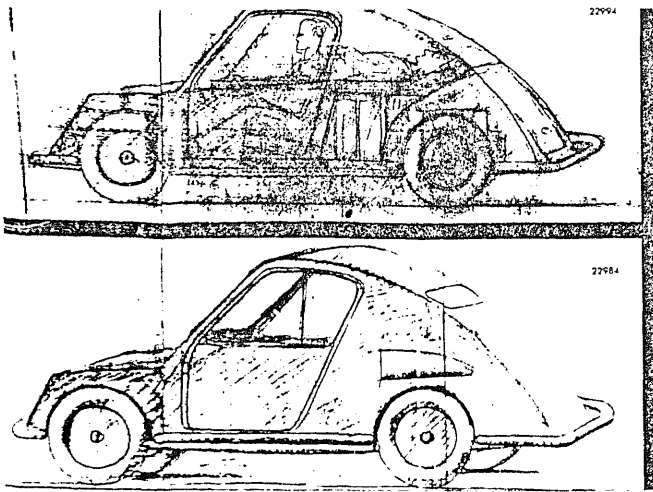

Le Corbusier  
Maximum car

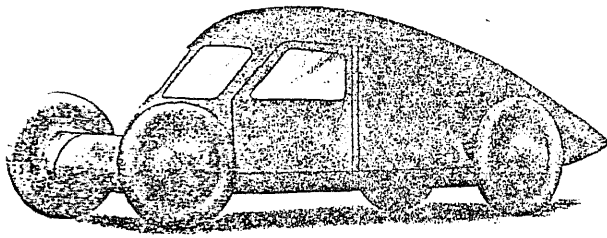

CLAVEAU

1923 Claveau

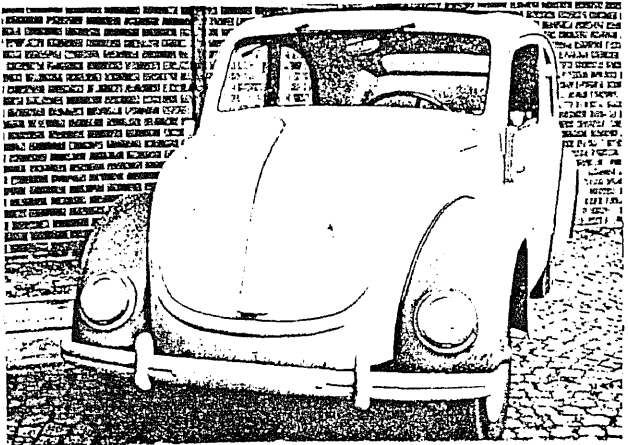
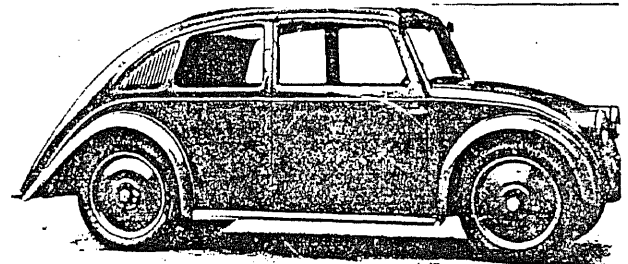
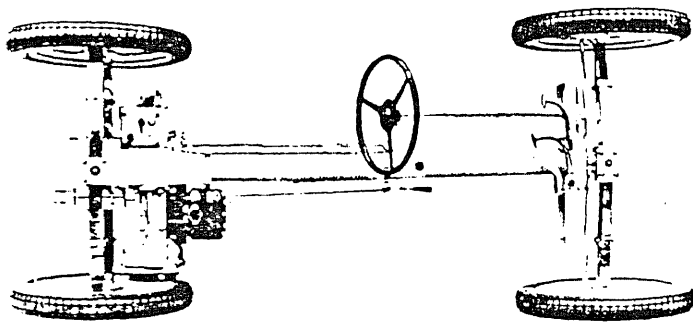

1930 Tatra

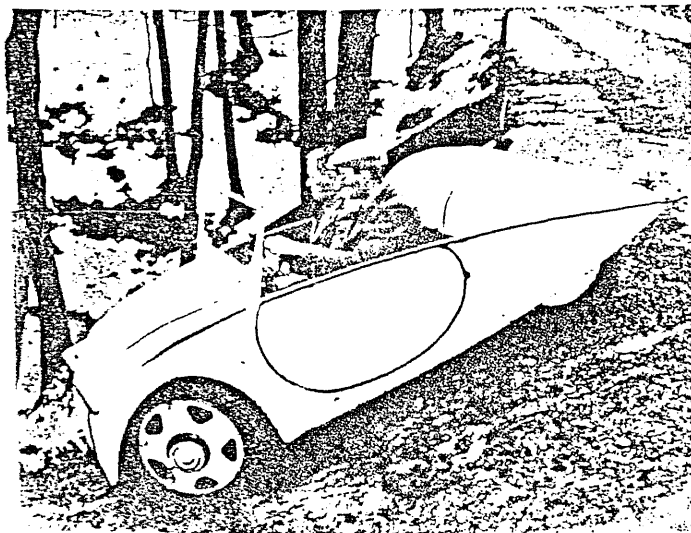

1934 Ganz

Corbu designed his proposal in 1928 and the contest was a good opportunity for presentation. He considered his design too different from the accepted ideas for car design in 1928. His main idea was to provide maximum comfort for passengers putting mechanical and structural concerns in second place. Passengers are shown in a roomy open setting not unlike a bay window at the front of the car. The engine was to be at the rear, to provide for less noise, fuel and oil odors. Coachwork was simple, consisting of a segment of a circle cut sharply in the front. In order to provide more interior space he used full track with no running boards and no fenders. Fenders appeared only partially on the front. Corbu provided forward visibility of 180 degrees for the passengers but rearward visibility was rather poor. Comparing his "Maximum car" with his architecture we can find similarities in concept and in philosophy.

Corbu's automobile has simple, plan forms and structure much like his architecture. There were no car ornaments, and the design emerged according to internal function. The semi-open cabin, by providing forward visibility symbolically represented his philosophy and his belief in the future and in technological superiority. On the other hand, by neglecting mechanics, he has created a static rather than a dynamic object.

Consequently his car is almost undrivable, which corresponds to the fact that many of his buildings are not comfortable to live in. This is true for his housing projects of that time, such as Villa Savoy or the housing development near Bordeaux. Comparing Corbu's design to other car design of the 1920's it is evident that he was not the first to introduce the idea of coachwork. Hanomag Kommissbrot presented it in 1925 with a similar concept. His version, a two seater, was quite unconventional. It is even simpler than Corbu's car, with very subtle details.

In 1923 a Frenchman, Emil Claveau, introduced his project: a streamlined car. Again, a similar concept, but aerodynamic, with smoother lines and edges. On the other side of the Europe in Rumania, in 1923, Aurel Persu designed his version of the streamline car, highly unconventional, with no bumpers, and with futuristic ergonomics and other interesting features. The contest produced many similar schemes and although airflow was a major issue Corbu's design dealt with airflow superficially.

In fact, concerning basic form and concept, Corbus "Maximum car" is not very original. Nevertheless there is originality in his treatment of simple lines and forms, slightly curved body surfaces, and the providing large interior space relative to overall size was a point which should be emphasized. Many of these ideas have appeared in car design since that time, attesting to the fact that Corbu seemed to have a good sense of what was emerging at the time.

In 1933, Richard Buckminster Fuller hired a well-known naval architect and aeronautical engineer, along with a crew of expert machinists, sheetmetal workers, woodworkers and coach builders, and in Bridgeport Connecticut he set up facilities for the design and production of Dymaxion Car Number One.

The main focus for Fuller was airflow and the vehicles driving capability. He intended to design coachwork through wind tunnel tests and mathematical calculations. The Dymaxion Car was a continuation of his experiments with Dymaxion House and his perception of the house as a dynamic rather than a static object. The car was actually one aspect of his philosophy and illustrated his views regarding the new era of transportation.

His ideal vehicle for that new era was originally the Zoomobile. It was a combined land and air vehicle capable of taking flight. The idea of a land/air vehicle was not new one and the mechanical system he proposed was known to engineers of that time.

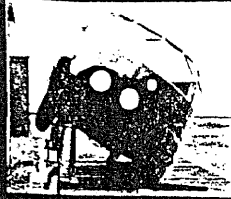
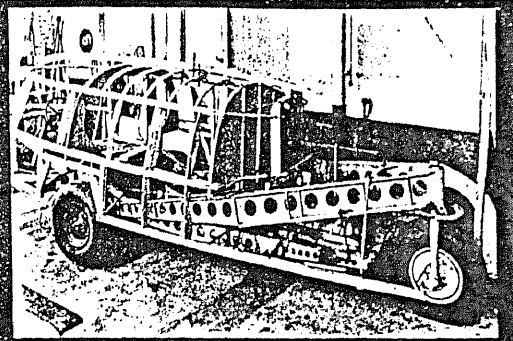

Top left for conductor Leopold Stokowski. In left and front Dymomon car covered the cost of the 1934 Chicago World's Fair. Its glass windows, twin rear-view mirrors, and cruise bumper. Hollow tail is raked out but engine room air and trapped it into the under to reduce drag. Also This suspension and cruise bar-up of left and a track scale was used to obtain the wheel loadings of the second Dymomon. Center of gravity was 23 inches, but for that time. Yes, there were additional vapor problems. Right: View of the front and rear car shows the complex five-frame chassis. Interconnection between front and rear suspension gave the car a road-holding position comparable to today.

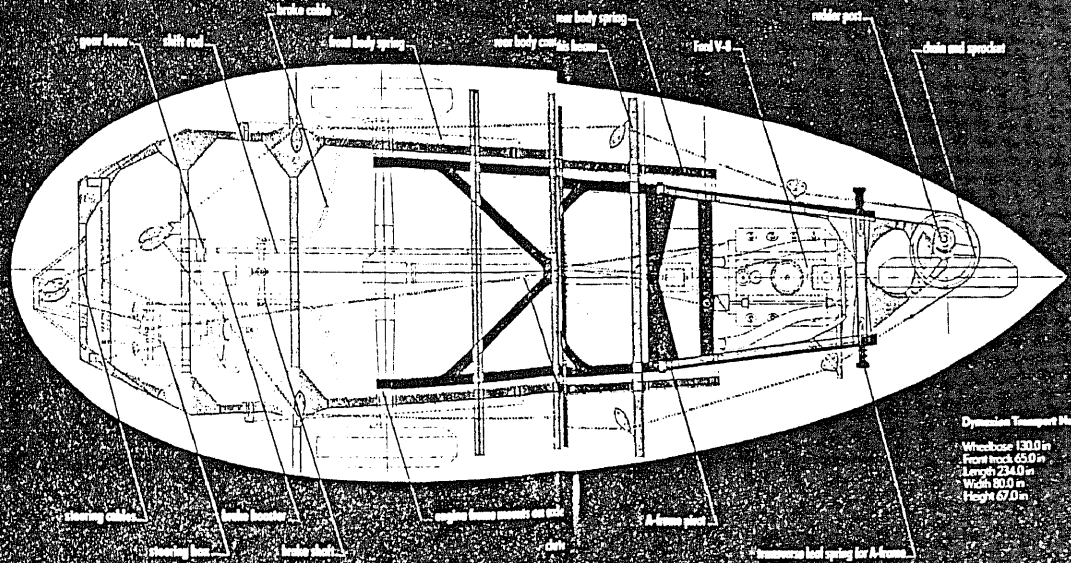

Dymomon Transport Number  
 Wheelbase 120.0 in  
 Front track 45.0 in  
 Length 234.0 in  
 Width 80.0 in  
 Height 67.0 in

KEY  
 Solid lines Body frame  
 Dashed lines Engine frame  
 Stippled lines Rear suspension frame

The earlier Stout Scarab had a steel body on a steel hoop chassis and boasted exceptional interior space

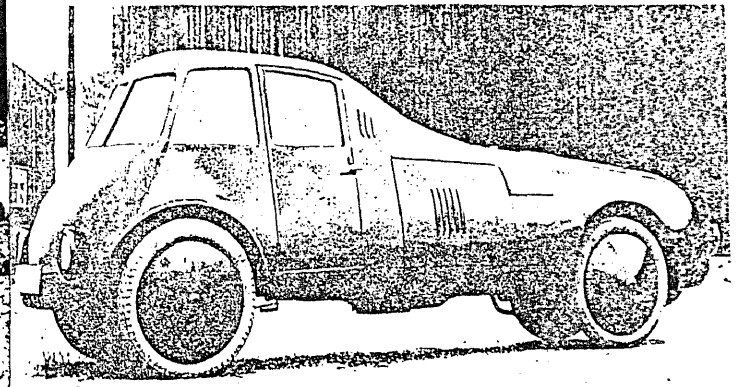
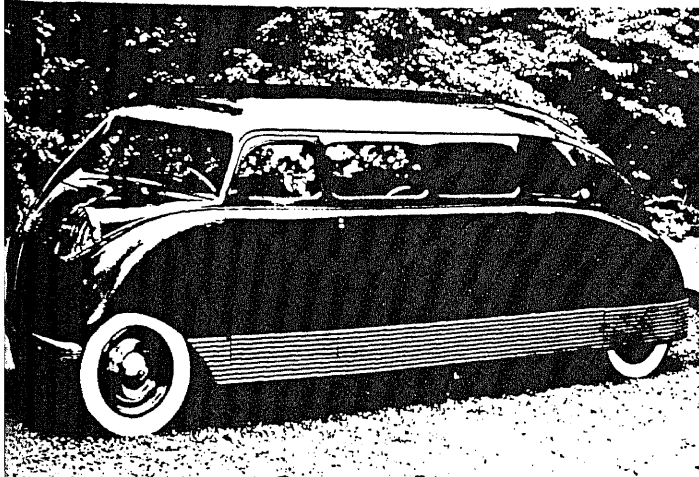

Von der Seite gesehen.

Stout Scarab 1931

Aurel Persu's aerodynamic automobile 1923

Aircraft- and yacht-building technique—aluminum skin on bent wood framing—resulted in a nineteen-foot, eleven-passenger car weighing only 2300 pounds. The huge rear suspension A-frame pivoted directly on the front axle, reducing gyroscopic reactions by keeping all wheels perpendicular to the road at all times. With 75 percent of the weight on the front axle, no rear brake was fitted. Note the lever shock and tension rods connecting the A-frame to the main chassis.

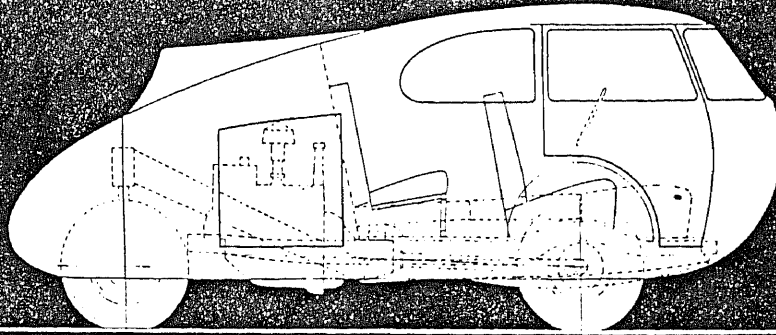

Fuller himself drew this Tudor Sportster version of the Dymaxion Transport; it was never built. The design clearly presages the 1943 Henry J proposal.

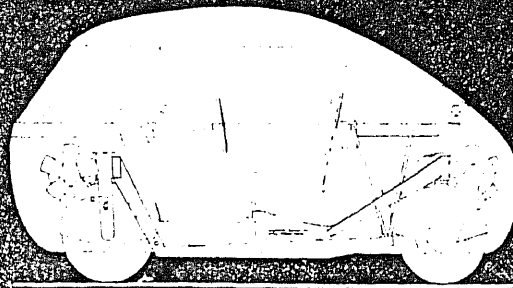

The last Dymaxion designed was this 1943 proposal for a 960-pound Kaiser Henry J. It featured a traffic-friendly nine-foot length, four-above seating, and a tiny five-cylinder radial engine in each wheel. Front-wheel steering was augmented by a crank-operated swiveling rear wheel for tight spots. Another version of the car had three little gas turbines in dual-tandem-wheel; the rear one on a telescopic boom that extended the wheelbase at high speeds. Both versions used Citroën-esque hydropneumatic suspension.

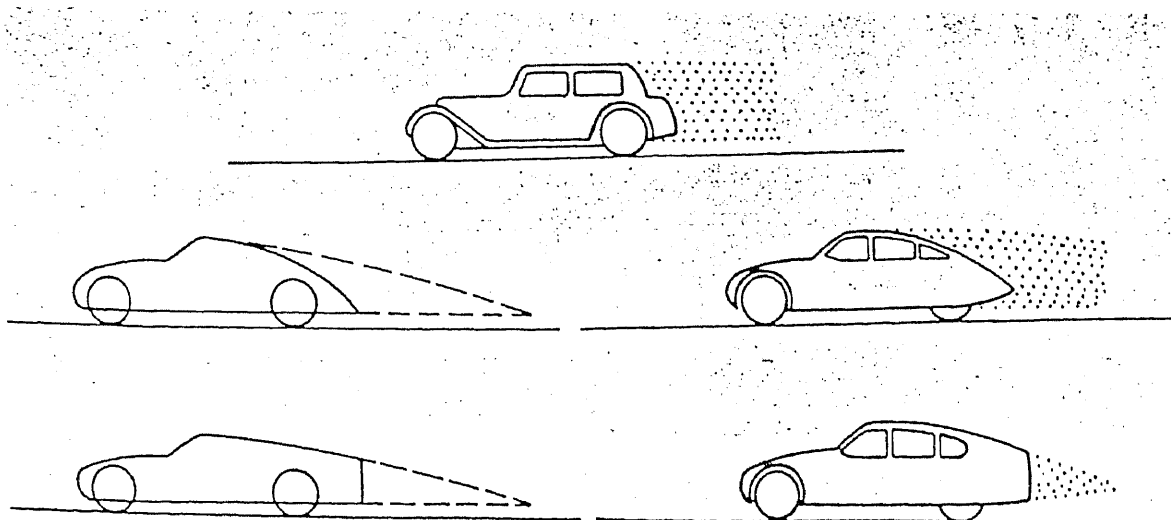

Kamm's aerodynamic's

Eventually, practical considerations forced him to abandon the idea and concentrate on the less ambitious Dymaxion Car.

The Dymaxion Car had a three-wheeler teardrop shape with a V-shaped channel at the back. It had a single steering wheel in the back with the engine beside it. The vehicle was supposed to be very fast and a fuel saver, but there were many unsolved problems of mechanical nature. The Stability and balance of the car were not adequate for the projected speed. Also, the interior space would seat only four people and the front seats were too much in front of the front axle.

Plans for the mass production of Dymaxion car were abandoned after a tragic accident at the "Century of Progress" exhibition in Chicago. Although the accident was not a direct result of the car's questionable construction it determined the fate of Fuller's dream car. In 1943, Fuller designed two smaller versions of Dymaxion car but they were never built.

The Dymaxion Car was only one piece in his architectural philosophy, as a hard-line functionalist he believed that functionalism cannot be pursued without a knowledge of structural mechanics and chemistry. He criticized the "International Style" for peeling off:

"...yesterday's exterior embellishment to put on, instead formalized novelties of quasi-simplicity, permitted by the same hidden structural elements of modern alloys that had permitted the discarded Beaux-Arts garbmentation.." (Curtis, 1985, p. 180)

In keeping with his functionalist theory, Fuller's goal in car design was to achieve proper airflow, but this could only be the result of a form minimizing air resistance. Good aerodynamic form needed structure as a support but that meant a departure from

53. Alder Cabriolet. Interior, showing reclining sea

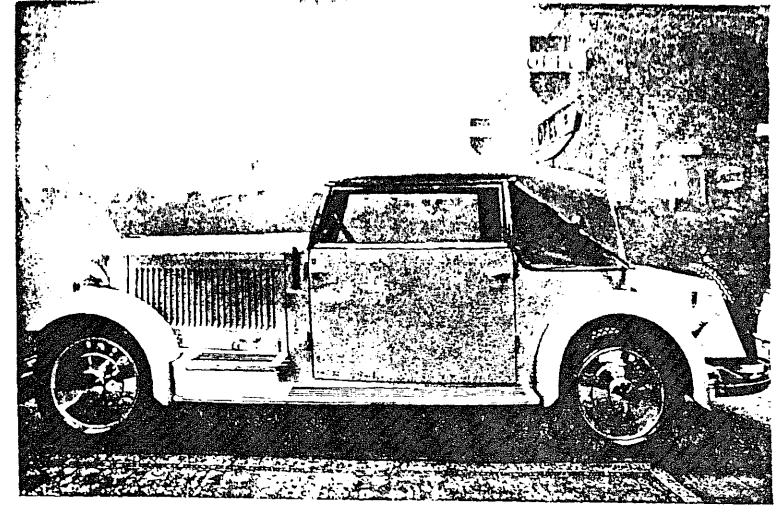
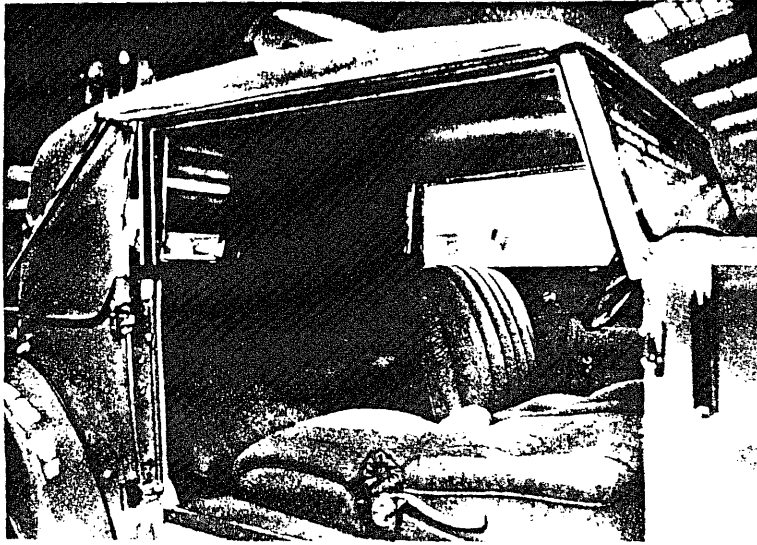

2. Alder Cabriolet, 1930.

Adler design by Gropius in 1930

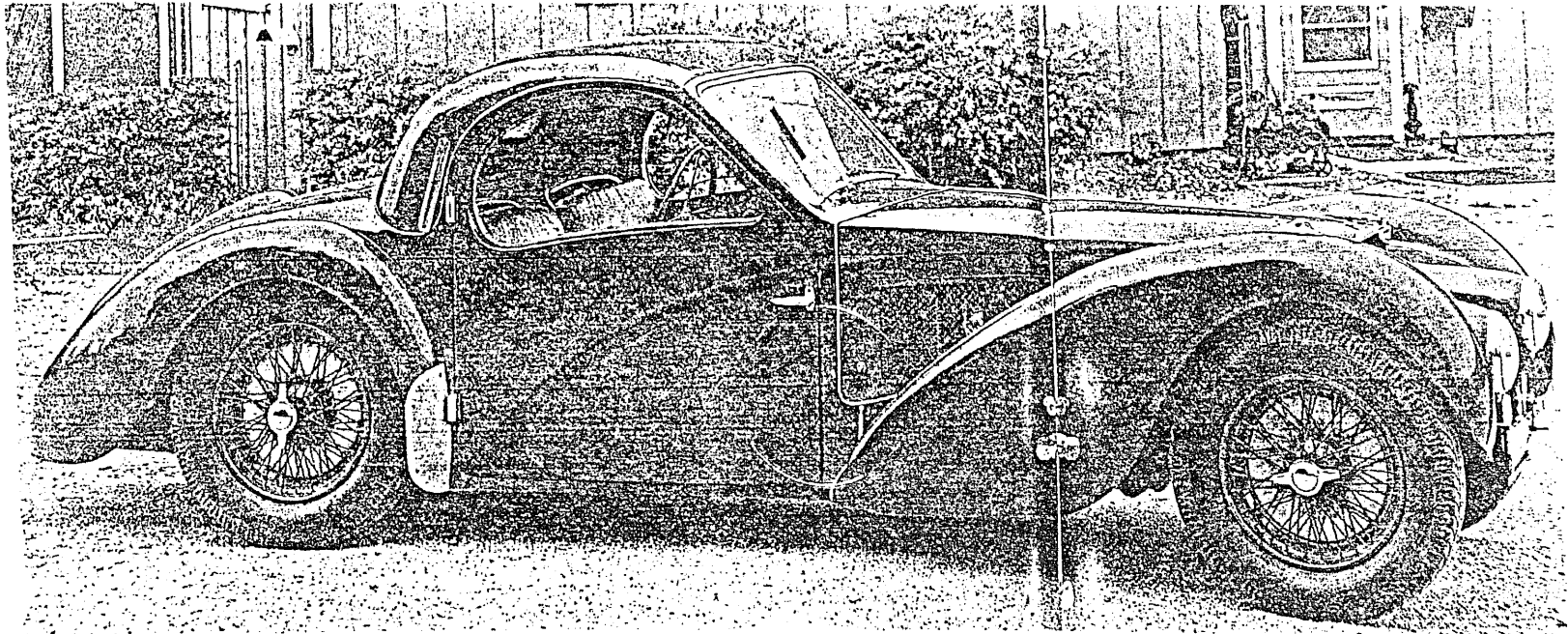

Bugatti from 1929

Fullers' basic beliefs, on account of the hidden structure that would be required. Furthermore aerodynamic form is most honest when it can be proved to stand the test of wind tunnels and calculations, as based on wind resistance. Dymaxion car was aerodynamic but not among the best. The mechanical system was more exotic than reliable. The frog-like appearance was unfinished and rather ugly.

In the 1930's Walter Gropius was engaged by the Adler automobile factory to design several variations of an automobile. He presented a sedan coupe and a convertible. The convertible won the award at the Paris Auto Show for successful design. It was a typical design of that time, with a front axle and a long hood extending into the cabin, continuing with the rear axle and trunk. The fenders were visible, and designed in a simple circular manner. The front hood and cabin were integrated, but the trunk was simply attached to the back of the cabin. Panels were curved slightly but remained simple. Elegance and luxury were emphasized in terms of the fashion of the time.

The Adler did not champion any revolutionary form or structure. In fact, the car was not distinctive in any single detail. In comparison with his theoretical thoughts and statements, often considered very radical at that time, the Adler design was not very innovative or challenging. The theory of design according to the Bauhaus school can be summed up in five basic statements:

- 1."The Bauhaus believes the machine to be our modern medium of design and seeks to come to terms with it."
2. All design must recognize this fact of life and distill a new set of esthetic criteria from it. Such processes would, for architecture, lead to "clear, organic (form) whose inner logic will be radiant and naked, unencumbered by lying facades and trickeries."
3. The Bauhaus teaches "the common citizenship of all forms of creative work and their logical independence upon one another."
4. The scale and complexity of modern problems necessitates collaborative design. "Any industrially produced object is the result of countless experiments, of



long systematic research." The design school must recognize this and equip the student with the common basis on which many individuals are able to create together, and a basis on which many individuals are able to create together a superior unit of work."

5. The education of the designer "must include a thorough, practical manual training in workshops and be actively engaged in production, coupled with sound theoretical understanding of the laws of design."

These five principles show clearly what Gropius had in mind and they demonstrate his ability to anticipate problems. For him the designer was removed from any control over, or real understanding of, science and technology. Processes of design consequently deteriorate into mere cosmetics, they become a prisoner of fad and fashion. Adler automobile was created with the fashion of the time.

In the summer of 1978 Renzo Piano and Peter Rice were called by Fiat's managing director to design a car of the nineties. It was an ambitious proposal and went beyond simple restyling. The ultimate goal was to alter basic ideas about what a car is, not only in the sphere of styling but in concept as well.

In order to meet this challenge, the Institute of Development in Automotive Engineering (IDEA) was formed in Turin and with the budget of 3 billion lire. For the period of three years Piano worked with a team of specialists. The collaboration was crucial for the success of design. It was a multidisciplinary achievement, emphasizing innovation and an anti- parochial design process.

The basic design objectives were separation of the function of the mechanisms and protection of the passengers, which led to a car structured of separable and interchangeable elements. The process was partially experienced in architecture by Piano on Beaubourg, and was already widely used in the field of electronics.

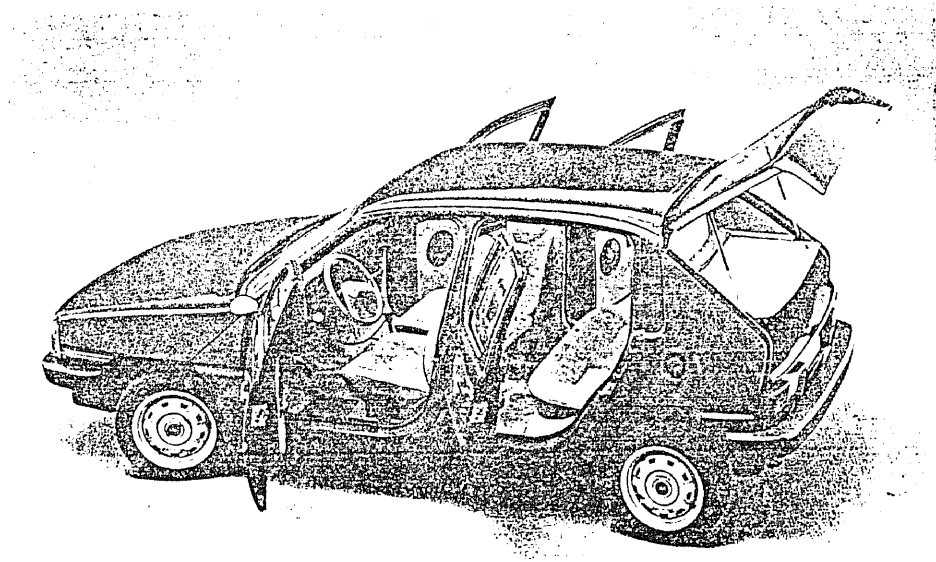

Piano's VSS car designed for FIAT

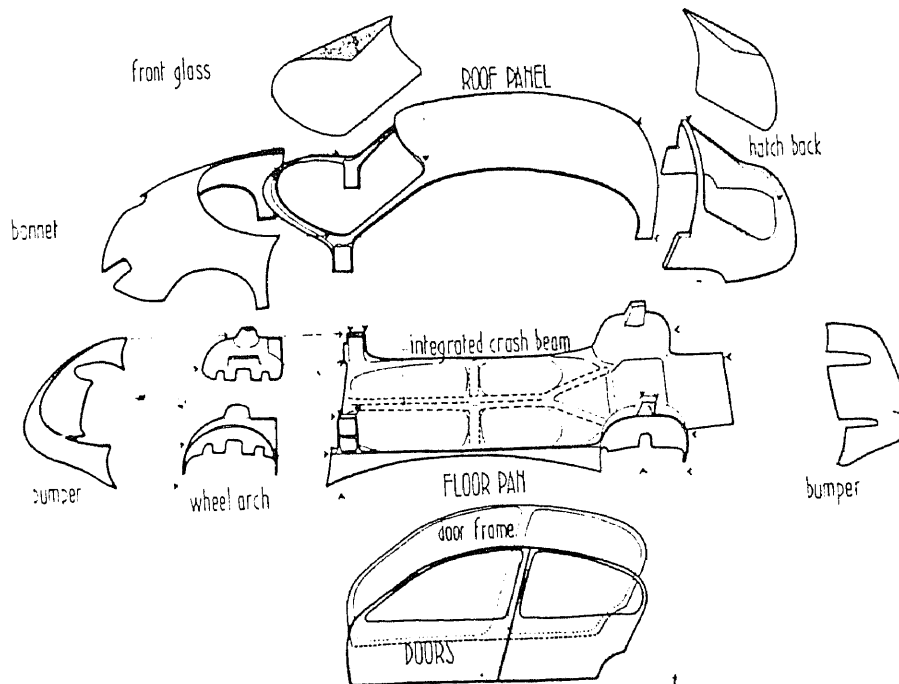

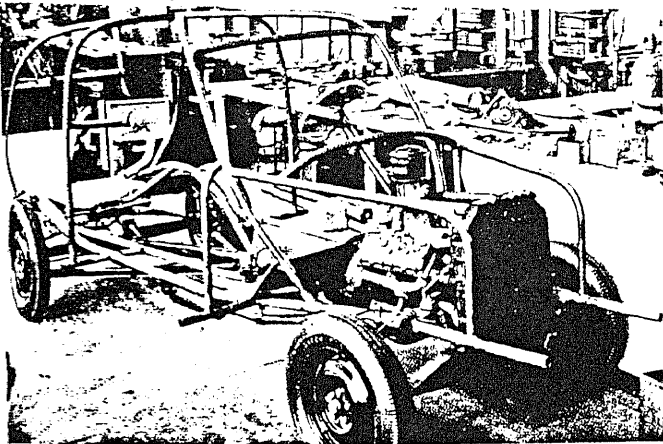
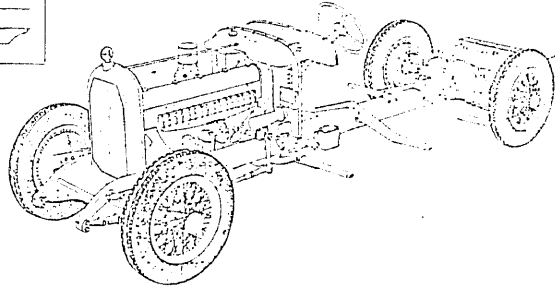
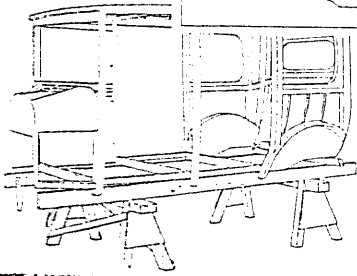
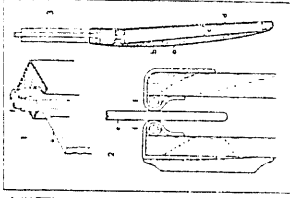
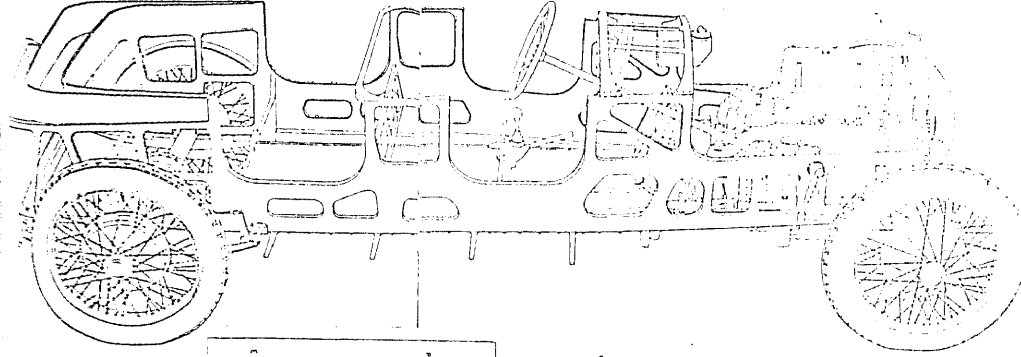

different bearing structures developed through the history

Had's soybean car had tubular frame and fourteen surface  
steel. He bought acreage in Dearborn to grow the beans for it.

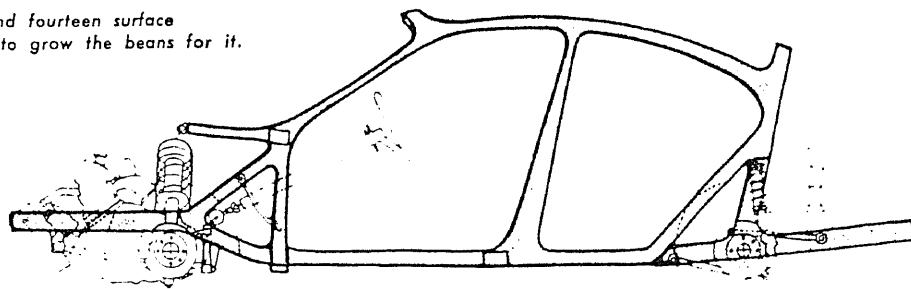

ELEVATION

Bearing frame  
for VSS car

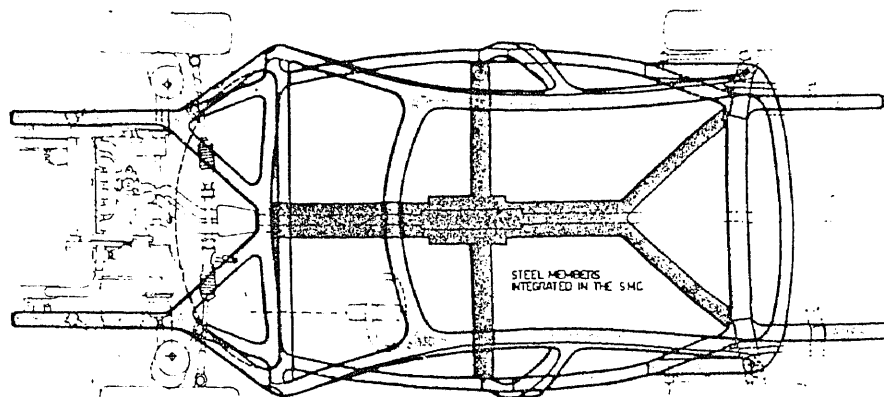

PLAN

STEEL MEMBERS  
INTEGRATED IN THE SMC

The goals they sought to achieve were in terms of weight, durability, safety and comfort. Weight was very important because they wanted to keep it as low as possible and yet the structure had to provide for safety and durability. Certain plastics and their compounds were suggested as replacements for steel but they suffered from a lack of torsional rigidity and insufficient safety in case of an accident. The final solution was a bearing galvanized steel frame, capable of absorbing shocks through progressive collapse of the material. The structure was lighter by 20% than the standard structure made of sheet metal. The number of welding points on the steel frame was greatly reduced and, because the whole frame had relatively small parts, giant hydraulic presses could be eliminated. An open frame provided easier mounting of the power train, suspension systems and other components. The skin was built of polycarbonates which are rust proof and durable providing a longer life for the car (twenty years) and decreased noise due to its resonating on lower frequencies. There were fewer elements. For example, each door had only two parts, the engine compartment had one instead of four.

After a long and detailed study in which each component and the whole product were tested at an experimental and mathematical-analytical level, several interesting conclusions emerged. Separation of structure and form was very good solution because it decentralized the production cycle and made it possible for numerous components to be manufactured in numerous production facilities and assembled on a large scale in one place. By retaining the central frame unchanged, it was possible to produce a wide array of forms with minimal investment. The design was open-ended, producing an unfinished product which could be adapted according to the users' requirements. The effect of this method of production was evident in both a practical and theoretical sense. The idea of a finished and perfected object was changed in favor of adaptability.

Production feasibility was a different issue. There were many pros and cons as to whether the car was ready for mass production or not. Although it was a car that could be built with less labor and without huge machines, with fewer parts and fewer maintenance problems, a car that would last longer and serve better, its production required a complete change of the existing main and subcontractors production capacities. Significant difficulties were encountered in attempts to work with the new materials, primarily plastics, and their compounds. Plastic is derived from oil and its price and availability can be subject to sudden change, bringing instability into the world of production.

But Piano saw another even greater problem to overcome in the marketing of a automobile: Unfortunately, the cultural breakthrough was followed by a certain cultural regression. Fiat felt the need to concretely include the research into a prototype. But its prototype had its problems. While it did weigh 20% less than the "Ritmo" model, it did not manifest design innovations that provided a domesticated image in keeping with current criteria.

In 1978 Piano worked on another, radically different vehicle. This was a platform for transport of people and material to North African countries, a suggestion proposed by the IDEA's managing director. They called it the "Flying Carpet", and began by exploring ferrocement technology and its potential use for vehicle production. The final product was a simple flat bed truck with a platform made of ferrocement and mechanical components. The base model could be converted into several other options. The engine would be produced in Italy but all other components wherever there was a need for the vehicle. It was a simple answer to the not so simple question of how a transportation vehicle could serve Third World needs. The answer has far-reaching consequences for the rest of the world as well.

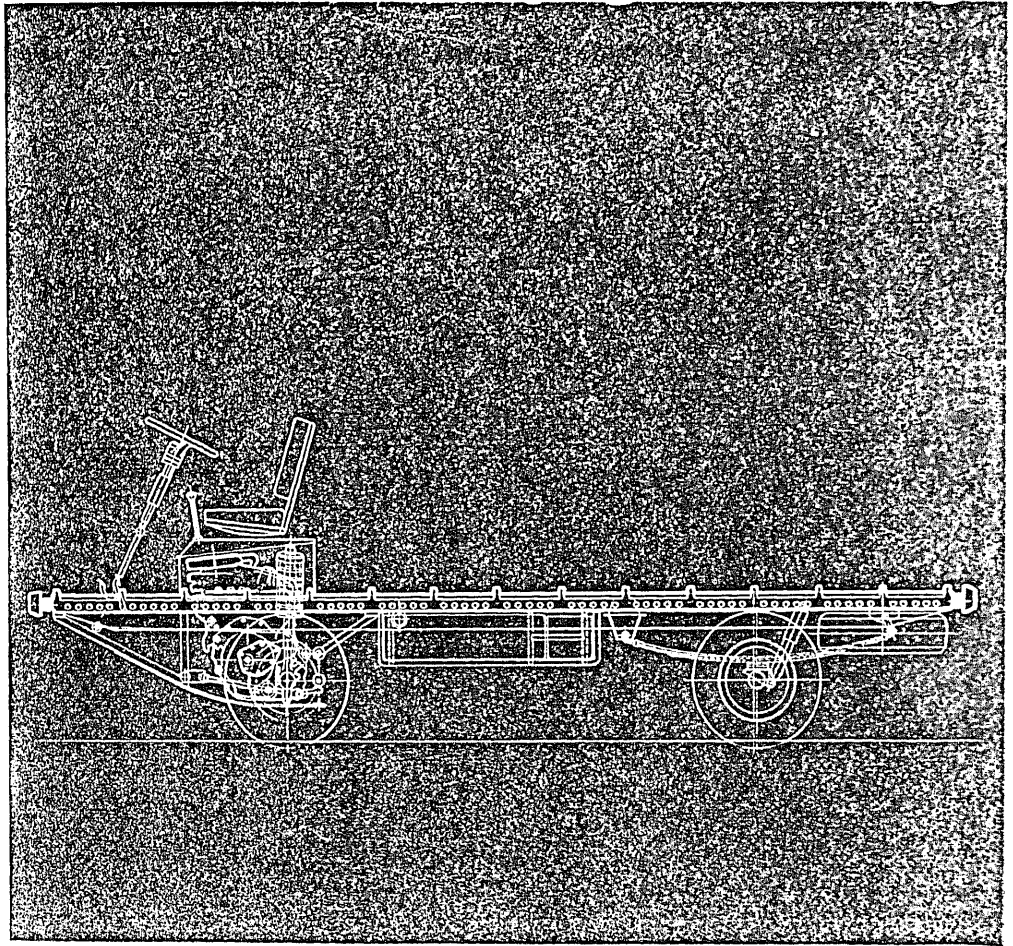
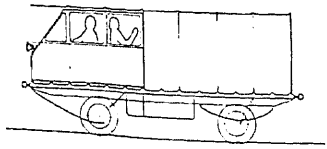
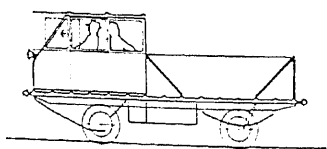
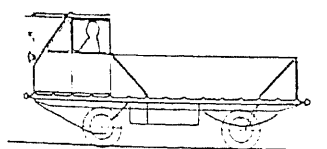
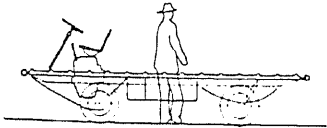
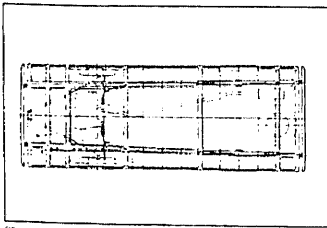

Flying Carpet designed by Piano in 1979

This concludes a survey of four giants in the field of architecture, who presented design schemes for automobiles. Three of them worked on the problem in the 1930's one in modern times. Each experience is unique and leads to a different conclusion.

For Corbusier the car was an important part of his urban philosophy: his city plans could not function without automobiles. Consequently the car had to be affordable for as many people as possible. The "Maximum car" was his answer to the problem. Since he was not curbed with any industry requirements, he did not have to think about mechanical details, and was free to say whatever he wanted. Simplicity and functionality were goals he intended to reach, and in part did so. In other regards the car was a less interesting object for him. Although he admires cars and a whole chapter in his book "Toward A New Architecture", is devoted to cars, he never worked on a car design again. Maybe he believed that Maximum Car was already perfected. It would be hard to know. Regardless of his motivating thoughts, he achieved functionality and simplicity in an original, aesthetic solution, and formed a new trend which was to become active thirty years later.

Gropius's experience in car design is more interesting for his own sake than for the sake of his results. It is difficult to find in his work examples of the interesting new features which he explains in his statement about the role of the industrial product in daily life. His social statements are even further afield. There are no signs of the radical mind that was clearly at work in his proposals for and artifacts of building design. On the other hand, it is important to recognize that he worked for a well-known factory of that time, and was probably not able to make an independent or original statement independently. The approach of no hassle and least effort tends to produce conservative results. That was, and still is, a feature of the car industry. Forty years later, Renzo Piano will come to the same conclusion.

Although Adler's proposal was not superior it was also not inferior when compared to the best achievements of the time.

Fuller's experience is interesting because of his exotic goals (Zoomobil), his theories and in some ways the results. He adopted the most progressive and exotic solution of his day but he was not the only daring designer. Three wheelers had already been invented and even the Zoomobil idea was not entirely new. His knowledge of aerodynamics was actually insufficient (Kamm had already found good aerodynamic form for the land vehicles), and none of these ideas he explored in depth. Nevertheless, Fullers' efforts were impressive and the Dymaxion Car was an ambitious project. In spite of great difficulties, he persisted for a significant length of time, during which three variations of the Dymaxion car was produced. Each improved on the previous model. Fuller was one of a small group of enthusiasts who explored new frontiers and although his Dymaxion car did not initiate a revolutionary period in the car industry, his enthusiastic approach was highly commendable.

Pianos experience is the most recent of the four. It came about because of an assignment from a complex and contemporary automobile company. Conceptual ideas developed during that time were far reaching and concerned the redesign and restructuring of the automobile. It was an attempt to redesign cars from outside the forces of the car industry establishment and overwhelming influence of the commercial production. The idea of deconstructing the car was not entirely new. In fact, an integrated body structure was introduced as early as in 1930's when cars had a chassis as a base on which everything else was to be mounted. A wide range of coachwork could be mounted on the same chassis. As the speed of travel increased, the structure was no longer strong enough and an integrated body was developed to solve the problem. Bearing frame was a combination of both, and used the advantages of both.



The issue of creativity's place in a big industry was also at stake during this project. According to Piano it was a question of "...whether the automobile industry wants to treat the user as an adult or not. In the long run, faith in the public, confidence in their ability to understand innovations, even in automobile forms, is likely to pay off." Although the project was abandoned, and unfortunately the idea unfinished, the experience remains and the future will probably confirm even more of its value.

## VIII. THE FUTURE

In previous chapters I analyzed different aspects of the relationship between architecture and the automobile. Now I will attempt to consider the future. Future options will not be analyzed on the basis of questionable predictions from the realm of technical and aesthetic fantasies, rather they will be reviewed in terms of today's problems and potential solutions.

A research study conducted by the MIT on the future of automobile concluded :

"The evidence cited indicated that automobility faces no serious threats over the next 20 years from energy shortages, environmental crises, social unacceptability, or rival modes of travel, provided that auto technologists continue to improve the product and to address changing operating conditions." (The Future of the Automobile, 1983, p.63)

Their conclusion addresses the social and economical realm, taking for granted that the automobile will be sufficiently improved. The process of car design is truly a complicated process, involves thousands of people of all disciplines, a process which takes, from start to finish about 4-6 years, hundreds of variables, and great uncertainty about problems and potentials. Unfortunately the complications are not resolved in the final product as one look in any engine compartment will confirm. It has the look of a decomposed deconstructivist composition. Zevi would be proud to see that, and Corbu probably very disappointed. After so many years of planning and designing it seems that the engine compartment, where it all comes together, has been sorely neglected.

Automobiles of today are poorly systematized objects because of the philosophy of design on which today's automobile companies rely. This is absurd. In an article entitled "The decline of Western civilization" which appears in "Automobile" magazine, an interesting comparison is drawn between "Hyundai" and the "Bugatti Royale":

"You could quite accurately replicate a Bugatti Royale for a lot less than the six or eight million recently paid for a couple of them,... Curiously, it would cost you a lot

more to build a mass-produced popular car from scratch, because it would be realized by physical means requiring extensive investment. I'm talking of really making a car from raw materials, not building up a fake from similar pieces... Today's Hyundai has standard features you couldn't have bought on a Cadillac not too terribly long ago, but it and most of the other cars on the market pay for their luxurious features in one way or another. There are not very accurately assembled, not terribly well painted, and they're made with materials that won't stand the test of time. As cheap grades of plastics took over from metals, longevity diminished. Replacement parts cannot readily be made, not without incredibly costly molds and dies that only a major manufacturer can afford. So it is a lot easier and cheaper to build a perfect Bugatti replica than it is to copy a "simple modern car like the Hyundai." (Automobile, July, 1988, p. 46)

The author continues with a projection into the year 2018:

"...when wealthy car lovers are nostalgic about Porsche 959s or Mazda RX7 or BMW 750iLs, they're going to have to content themselves with finding the real thing and rebuilding it to their modern standards or doing without. They'll never be able to re-create all the little molded plastic pieces that contemporary cars have in them, nor will they find anyone who can cook up batches of antique silicon chips for the period electronics." (Automobile, July, 1988, p. 47)

Today car production is based on a "waste philosophy". It is an absurd cycle in which enormous energy and resources are invested in an automobile's development and then, after "economic" goals are accomplished, everything starts from scratch. An exaggerated belief in the power of technical means is making previously accumulated experience irrelevant.

It is not unusual to see that in overall value, a less advanced car supersedes a more advanced one. Car weight is a good example. There is a great enthusiasm in the car industry for light weight materials such as plastic, alloys, magnesium, titan, kevlar, composites, etc, but despite that fact, today's cars are becoming heavier and heavier. VW Beetle weighed approximately 750 kg, where as today's Golf weighs 950 kg, for about the same volume.

The MIT study relies heavily on new technologies and methods available now and in the future but the car industry is not so quick to assimilate technologies. It is basically

a conservative and cautious industry which is reluctant to adopt novelties and, as for actual technical advances, they are very infrequent. In fact, most of the technical solutions date from the period between WWI and WWII.

The VW Beetle is more systematized than any VW produced today. It is true that today automobiles are faster and stronger, the bodywork more rigid and aerodynamic but it is also true that they have not developed the technical aspects in a similar fashion.

The bodywork of today's automobile is a system unsuited to change and adaptation. Elements of the unitary body structure are so interrelated that changing only one element can necessitate changes on many other elements as well as the overall structure of the car. This forces producers to choose a risk-free approach as far as form is concerned and the decision making process as to size, shape and type of body trim becomes a very delicate process. Allegedly public opinion is tested as part of the process in order to entice the public without greatly increasing design risks. That's how we get such typical designs from many different manufacturers. Try to distinguish the front end of today's Honda from a BMW or a Ford. This similarity does not result from the use of a standard element. In fact each model is slightly different, not only in size but also in shape. Differences in shape are sometimes so minimum that only close examination can determine it.

In contrast to automobile design, architecture is technically diversified. So much so that it's difficult to make a consistent analysis regarding systematization. The average building is less technically complex than an automobile which makes it possible for architecture to operate on a low level of technology without a deep dependence on today's high-tech world. Despite this independence, or even because of it, there are many chaotic buildings which are anything but systematized.

Generally speaking architecture has more individual achievement in experimental areas and although the solutions may be controversial they are very valuable in opening the way to the future. The automobile should in the sphere of pure technique be truly technical, but in the sphere of aesthetics it should be open to adaptation and change. This is actually the reverse of the situation as it exist today. Technical aspect should rely for its part on simplicity. We cannot choose between technique and something else but we can certainly pursue simplicity whether it be in structural or organizational areas. I don't believe that we are forced, because of the nature of technique, to choose more complicated solutions. On the contrary, we have an obligation to find simple technical solutions for technical applications that surround us. Switches, levers, doors, windows, engines and other functions, that are part of our everyday life, should not become an obstacle for normal living nor should they need to depend on other technical systems. The modular design of computers is a good example of this what this facility means, since we don't have to be computer experts to put together a personal computer. A little enthusiasm and the job can be done. We also do not have to know how a computer functions in order to operate it. How many people know how shoes are made, yet they manage to tie their shoelaces.

Structure, on the other hand, involves aesthetics and should be designed to provide for variety. The car industry has built a veil of mystery around the question of aesthetics, always trying to present us a dream of the future with incoming models, but it is usually their dream. Interestingly enough, we do have a notion as to which car form is old and which one is new, this issue was already discussed, but again, the question of old and new form is relative and flexible. I and certainly some others, would not mind owning a car with a visual image of the thirties and yet having today's mechanics. I can't state a single aesthetic advantage of today's Mazda RX over the Jaguar E type, or

today's Ford Thunderbird over the Thunderbird of 1956. The choice between them is simply a question of taste.

What, then, is the point of the enormous energy spent in trying to choose the car of the nineties? Manufacturers should respond with an open system of production that can bear a variety of forms which can be replaced as need be. The demystification of the system could be accomplished by making technical applications simpler and form more open to style. The result would be a kind of technology which doesn't pose itself as a mechanical beast.

I will return back to Frank Gehry and Renzo Piano at this point in order to discuss their approach to technology. Both Gehry and Piano share a specific view in regard to technology. Their expressions are different but the lessons we can learn from their work are, on some points, surprisingly similar.

Piano's deepest conviction:

"...is that the architect should first design his own working instruments, his technical and disciplinary equipment. This is a sort of return to one's origins which is further justified today in the light of conventionalism and mass production of the conceptual process. If one does not intervene in the making of instruments, in its processes, we risk having our work relegated to the periphery where there is only space for ineffective and nostalgic operations." (Piano, 1984, p. 7)

Piano goes on to speculate about the future of technology in architecture:

"Reappropriation of the work instruments; mastery in handling the materials and techniques of construction; the reformation of the professional role is the goal of a torturous journey back through the mythical countries of craftsmanship, the craft of building before anything else. This may well be the only formula which can heal the schizophrenia syndrome of contemporary architecture, close the ever-widening gap between humanistic and scientific culture, between thought and action, conceptual and manual work... We cannot free ourselves from the feeling of non-fulfillment simply by traveling back through time. Hurtling forward as we are towards the wonderland of data processing." (Piano, 1984, p. 7)

Piano finally defines technology as implicit in all building processes:

"The choice of technology is implicit in the choice to build. Even the use of stone corresponds to a precise technological option. It is simply that in an advanced period like our own, materials are available with high level of cohesion and durability that are easily worked and handled. It is culturally a mistake to reject the opportunity to mould the architectural language using all this potential. It is questionable even to make an issue of it. An architect, a builder cannot help but use technological methods when it meets the design requirements...to progress beyond one of the classic conflicts of modern art, the clash between creativity and science. Without the support of scientific developments, the aspiration of new architectural frontiers is destined to remain in the limbo of manifestoes and declarations." (Piano, 1984, p. 7)

Gehry also doesn't hide from technology, he is not a slave to stone or actually any other material but employs a wide range of building materials turning everything into a poetic element. He seems able to make a graceful structural element of a garbage can. His approach is artistic and sculptural and he does not hesitate to use different materials, one after the other, in creating his buildings.

Piano explores structural aspects of the technology available by spanning the whole process, from design to execution. He also creates building elements himself, on the basis of scientific knowledge that is available.

Where as Piano designs his own elements, and then experiments with them in his designs, Gehry experiments by exploring the unexpected relationship between materials.

They are both exploring and testing new possibilities without hesitation in the face of the "technological monster." This can be a valuable lesson for automobile designers. Glamour, splendor and clumsy dreams of well-being, along with the mysterious search for futuristic form are not the only possible destinies for today's automobile.

## BIBLIOGRAPHY

- Alexander, Christopher, Notes on the Synthesis of Form, Harvard University Press: Cambridge, Mass., 1970.
- Alexander, Christopher, The Anti-Aesthetic, MIT Press:Massachussets, 1970.
- Alexander, Christopher, Essays on Postmodern Culture, Bay Press: Port Townsend, Washington, 1983.
- Anderson, Atshuler, Jones, Roos, Womack, The Future of the Automobile, The MIT Press: Cambridge, 1984.
- Arnheim, Rudolf, The Dynamic of Architectural Forms, University of California Press, Berkley, 1977.
- Automobile Quarterly, Volumes: 10/2, 14/8, 15/8, 16/2, 19/4, 20/2, & 21/3, & The Automobile Quarterly World of Cars.
- Banham, Rayner, Theory and Design in the First Machine Age, MIT Press: Cambridge, Ma., 1980.
- Banevolo, Leonardo, History of Modern Architecture, Volume One, The MIT Press: Cambridge, 1985.
- Bayner and Pugh, The Art of Engineer, The Overlook Press: Woodstok, New York, 1981.
- Beattie, Ian, The Complete Book of Automobile Body Design, Haynes: London, 1977.
- Blackvel, William, Geometry in Architecture, John Wiley & Sons: New York, 1984.
- Box, Rob de la Rive, & and Crump, Richard, The Automotive Art of Bertone Haynes, 1984.
- Braudel, Fernard, The Wheels of Commerce, Harper & Row, Publishing: New York, 1982.
- Braudel, Fernand, The Structure of Everyday Life, Harper & Row, Publishers: New York, 1982.
- Braudel, Fernand, The Perspective of the World, Harper & Row, Publishers: New York, 1982.
- Bush, Donald J., The Streamlined Decade, George Braziller: New York, 1975.
- Car Styling, "Giugiaro & Italian Design", New York, 1981.
- Churchman, West, The Design of Inquiring Systems, Basic Books, Inc. Publishers: New York, 1971.



- Cirlot, J.E., A Dictionary of Symbols, Philosophical Library: New York, 1971.
- Curtis, William, J.R., Modern Architecture Since 1900, Phaidon-Oxford: London, 1982.
- Dean, Andrea Oppenheimer, Bruno Zevi On Modern Architecture, Rizzoli: New York, 1983.
- de Wit, Wim, The Amsterdam School, MIT Press: Cambridge, 1983.
- Dini, Massimo, Renzo Piano, Electra-Rizzoli: New York, 1984
- Ellul, Jacques, The Technological Society, Vintage Books: New York, 1964.
- Fabre, Maurice, A History of Land Transportation, Hawton Books Inc.: New York, 1963.
- Fitch, James, Martson, Walter Gropius, George Braziller: New York, 1960.
- Friedman, Yona, Toward Scientific Architecture, The MIT Press: Cambridge, Ma. 1980.
- Georgano G.N., Cars 1886-1930, Nordbok: 1985.
- Giedion, Siegfried, Mechanization Takes Command, W.W. Norton & Company: New York, 1975.
- Hambidge, Jay, The Elements of Dynamic Symmetry, Dover Publications, INC:New York, 1967.
- Rasmussen, Henry, Decade of Dazzle, Motorbooks Internation: Osceola, Wisconsin, 1987.
- Haylor, Gillian, The Bauhaus Reassessed: Sources and Design Theory, E.P. Dutton: New York, 1985.
- Hess, Alan, Google: Fifties Coffee Shop Architecture, Cronicle Books: San Francisco, 1985.
- Jencks, Charles, The Language of Postmodern Architecture, Rizzoli: New York, 1983.
- Jung, Carl G., Man and His Symbols, Modern Press:Laurel, New York, 1964.
- Kieselback, Ralf, Stromlinienautos in Europe and USA, Kohlhammer Edition Auti & Verkehr: Stuttgart, 1982.
- Le Corbusier, Towards a New Architecture, Dower Publications, Inc.: New York, 1986.
- Mumford, Lewis, The Myth of the Machine: Technics and Human Development, Harcourt, Brace, Jovanovich, Inc.: New York, 1967.
- Norbye, Jan, Car Design Structure & Architecture, TAB Books Inc.: Blue Ridge Summit, 1984.

Pearce, Peater, Structure in Nature is a Strategy for Design, The MIT Press: Cambridge, Ma., 1978.

Read, Herbert, Art and Industry, Horizon Press: New York, 1961.

Sedgwick, Michael, Cars of the Fifties and Sixties, Temple Press: Philadelphia, 1983.

Summerson, John, Heavenly Mansions and Other Essays on Architecture, The Norton Library: New York, 1963.

Summerson, John, The Classical Language of Architecture, MIT Press: Cambridge, Ma., 1963.

Trachtenberg, Marvin, and Myman, Isabelle, Architecture From Prehistory to Post-Modernism: The Western Tradition, Prentice Hall: Englewood Cliffs, 1986.

Vann, Peter, & Asaria, Gerald, Extraordinary Automobiles, Motorbooks International, Osceola, Wisconsin, 1985.

Venturi, Robert, Brown, Dennies Scott, and Izenour, Steven, Complexity and Contradiction in Architecture, The Museum of Modern Art: New York, 1966.

Von Eskardt, Wolf, Eric Mendelsohn, George Braziller: New York, 1960.

Wilkinson-Latham, Robert, Phaidon Guide: Antique Weapons and Armour, Prentice-Hall: Englewood Cliffs, 1981.

Windsor, Alan, Peter Behrens: Architect and Designer 1868-1940, Whitney Library of Design: New York, 1981.

Wisse, David Burgess, GHIA: Ford's Carrozzeria, Osprey Books, 1985.

Zevi, Bruno, Erich Mendelsohn, Rizzoli: New York, 1982.

Zevi, Bruno, The Modern Language of Architecture, University of Washington Press: Seattle, Wa., 1978.