

Copyright Warning & Restrictions

The copyright law of the United States (Title 17, United States Code) governs the making of photocopies or other reproductions of copyrighted material.

Under certain conditions specified in the law, libraries and archives are authorized to furnish a photocopy or other reproduction. One of these specified conditions is that the photocopy or reproduction is not to be “used for any purpose other than private study, scholarship, or research.” If a user makes a request for, or later uses, a photocopy or reproduction for purposes in excess of “fair use” that user may be liable for copyright infringement,

This institution reserves the right to refuse to accept a copying order if, in its judgment, fulfillment of the order would involve violation of copyright law.

Please Note: The author retains the copyright while the New Jersey Institute of Technology reserves the right to distribute this thesis or dissertation

Printing note: If you do not wish to print this page, then select “Pages from: first page # to: last page #” on the print dialog screen

The Van Houten library has removed some of the personal information and all signatures from the approval page and biographical sketches of theses and dissertations in order to protect the identity of NJIT graduates and faculty.

THE ACQUISITION OF
DIRECT SEQUENCE
SPREAD SPECTRUM COMMUNICATION
SYSTEMS

BY ^{Donald}
ANTHONY D. DEMERI

A THESIS PRESENTED IN PARTIAL FULFILLMENT OF THE REQUIREMENTS FOR THE
DEGREE OF MASTER OF SCIENCE IN ELECTRICAL ENGINEERING AT NEW JERSEY
INSTITUTE OF TECHNOLOGY

Newark, New Jersey
May, 1986

APPROVAL OF THESIS
THE ACQUISITION OF
DIRECT SEQUENCE
SPREAD SPECTRUM COMMUNICATION
SYSTEMS

BY

ANTHONY D. DEMERI

FOR

DEPARTMENT OF ELECTRICAL ENGINEERING
NEW JERSEY INSTITUTE OF TECHNOLOGY

BY

FACULTY COMMITTEE

APPROVED: _____

NEWARK, NEW JERSEY

MAY, 1986

VITA

Name: Anthony Donald Demeri

Permanent address:

Degree and date to be conferred: MSEE May, 1986

Date of birth:

Place of birth:

Secondary education: DePaul Diocesan High School, June, 1980

| Collegiate institutions attended | Dates | Degree | Date of Degree |
|------------------------------------|-----------|--------|----------------|
| New Jersey Institute of Technology | 9/80-5/84 | BSEE | May, 1984 |
| New Jersey Institute of Technology | 9/84-5/86 | MSEE | May, 1986 |

Major: Electrical Engineering

Positions held: Engineer, Singer Kearfott, Wayne, New Jersey 07470

Title of Thesis: The Acquisition of Direct Sequence Spread Spectrum
Communication Systems

Anthony D. Demeri, Master of Science, 1986

Thesis directed by: Dr. Joseph Frank

ABSTRACT

This Paper surveys different techniques of acquiring Direct Sequence Spread Spectrum Systems.

It classifies different systems, indicates the strongpoints and weakness of each, along with some applications.

One method, The Single Dwell Serial PN Acquisition System is then focused on in detail. The detail includes analysis of standard version, derivation of the mean time to acquire, the variance, the probability of detection and the probability of a false alarm.

In the last section of the paper the analytical results of the Single Dwell Serial PN Acquisition System shall be confirmed by computer simulation.

Blank Page

| TABLE OF CONTENTS | PAGE |
|---|------|
| BACKGROUND | 1 |
| DIRECT SEQUENCE SYSTEMS | 7 |
| INTRODUCTION TO ACQUISITION | 13 |
| SURVEY OF ACQUISITION TECHNIQUES | 16 |
| SLIDING CORRELATOR | 16 |
| SEQUENTIAL ESTIMATION | 20 |
| THE SINGLE DWELL SERIAL PN ACQUISITION SYSTEM | 22 |
| MATCHED FILTER SYNCHRONIZERS | 24 |
| UNIVERSAL TIMING | 26 |
| SPECIAL CODES | 27 |
| TRANSMITTED REFERENCES | 28 |
| THE MULTIPLE DWELL SERIAL PN ACQUISITION SYSTEM | 29 |
| ANALYSIS OF THE SINGLE DWELL SERIAL PN ACQUISITION SYSTEM | 34 |
| CALCULATION OF THE MEAN AND VARIANCE OF THE ACQUISITION TIME | 34 |
| CALCULATION OF MEAN ACQUISITION TIME FOR $P_{FA}=0$ and $P_D=CONSTANT$ | 34 |
| CALCULATION OF THE VARIANCE OF THE ACQUISITION TIME FOR $P_{FA}=0$ AND $P_D=CONSTANT$ | 39 |
| EFFECT OF NON ZERO FALSE ALARM PROBABILITY | 44 |
| EVALUATION OF P_D AND P_{FA} | 50 |
| COMPUTER SIMULATION | 52 |
| GENERAL COMPUTER SIMULATION REQUIREMENTS | 52 |
| SPECIFIC COMPUTER SIMULATION REQUIREMENTS | 52 |
| CODE LENGTH | 52 |
| GAUSSIAN NOISE | 54 |
| CORRELATION | 54 |
| THRESHOLD | 56 |

| | PAGE |
|--|------|
| FALSE ALARMS | 56 |
| MISSED DETECTIONS | 57 |
| FLOW DIAGRAM | 57 |
| SYNCHRONIZATION | 57 |
| RESULTS OF SIMULATION | 57 |
| COMPUTER PROGRAM | 62 |
| CONCLUSIONS AND RECOMMENDATIONS | 64 |
| APPENDIX I EVALUATION OF PROBABILITY DENSITY FUNCTION OF Y | |
| APPENDIX II | |
| SECTION 1 FALSE ALARM PRINTOUT | |
| SECTION 2 MISSED DETECTION PRINTOUT | |
| SECTION 3 SYNCHRONIZATION PRINTOUT | |
| SECTION 4 COMPUTER PRINTOUT FOR ALL S/N | |
| SECTION 5 PROGRAM LISTING | |
| LIST OF REFERENCES | |

LIST OF FIGURES

| <u>FIGURE</u> | | <u>PAGE</u> |
|---------------|---|-------------|
| 1. | IDEAL FREQUENCY SPECTRA FOR A DIRECT SEQUENCE SYSTEM..... | 2 |
| 2. | A TYPICAL SPECTRUM OF A 180° BIPHASE MODULATED CARRIER..... | 8 |
| 3. | BLOCK DIAGRAM OF A DIRECT SEQUENCE SPREAD SPECTRUM SYSTEM.. | 10 |
| 4. | TYPICAL FLOW DIAGRAM OF SLIDING CORRELATOR PROCESS..... | 17 |
| 5. | COMPARISON OF CROSS-CORRELATION OF SHORT AND LONG CODE SEQUENCES WITH A CW SIGNAL..... | 19 |
| 6. | BLOCK DIAGRAM OF SEQUENTIAL ESTIMATOR SYSTEM..... | 21 |
| 7. | BLOCK DIAGRAM OF A SINGLE DWELL PN ACQUISITION SYSTEM..... | 23 |
| 8. | A TYPICAL DELAY LINE MATCHED FILTER..... | 25 |
| 9. | TRANSMITTED REFERENCE SYNCHRONIZATION METHOD..... | 30 |
| 10. | BLOCK DIAGRAM OF N-DWELL PN ACQUISITION SYSTEM..... | 32 |
| 11. | 7 BIT FEEDBACK GENERATOR CONFIGURATION..... | 53 |
| 12. | CORRELATION PROCESS..... | 55 |
| 13. | FLOW DIAGRAM FOR SINGLE DWELL SERIAL ACQUISITION SYSTEM SIMULATOR..... | 58-60 |
| 14. | CURVE OF THE MEAN ACQUISITION TIME FOR A SINGLE DWELL SERIAL ACQUISITION SYSTEM..... | 63 |

LIST OF TABLES

| <u>TABLE</u> | | <u>PAGE</u> |
|--------------|--|-------------|
| 1. | PROCESS GAINS..... | 5 |
| 2. | COMPARISON OF DIRECT SEQUENCE WAVEFORMS..... | 11 |
| 3. | SUMMARY OF SIMULATION DATA..... | 61 |

BACKGROUND

A basic definition of a Spread Spectrum System is one in which the transmitted signal is spread over a much wider frequency band than the minimum bandwidth required for transmission.

A typical Spread Spectrum System takes a base band signal (with a relatively small bandwidth; for example a few kilohertz) and distributes the signal over a bandwidth of many megahertz.

The bandwidth spreading is accomplished by modulating the information to be sent with a pseudorandom code which is independent of the information.

When the Spread information reaches the receiver, it must be despread. The information recovery is accomplished by a synchronized reception with the pseudorandom code at the receiver.

The general types of Spread Spectrum Systems in use today employ Direct Sequence, Frequency Hopping, and Chirp Techniques.

A "Direct Sequence" Spread Spectrum communications system modulates the information by a digital code sequence whose bit rate is much higher than the information.

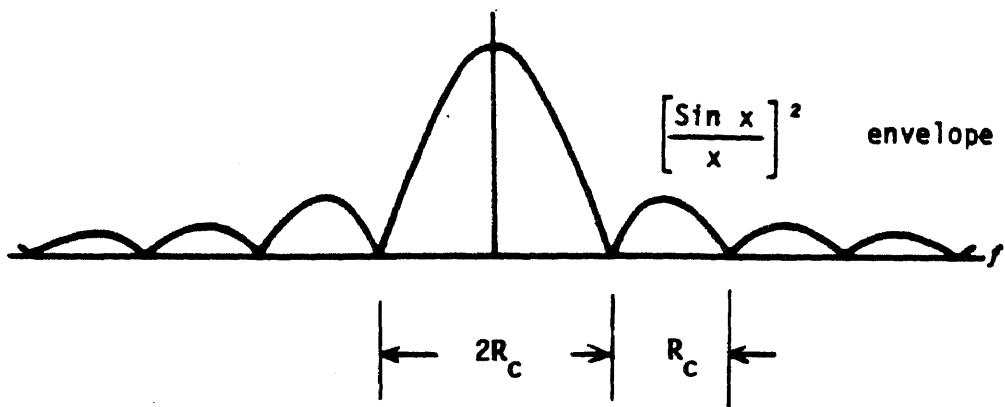

Where R_c equals the chip rate.

Figure 1 Ideal Frequency Spectra for a Direct Sequence System

Figure 1 shows a typical frequency spectrum for this type of system.

Next in types are the Frequency Hopping Systems. These systems shift the carrier frequency in discrete increments in a predetermined pattern, which is determined by the pseudorandom code.

In the Pulse Type Systems, the carrier frequency is swept through a wide band of frequencies during a pulse interval.

After understanding what Spread Spectrum Systems are, one would like to know why these systems are used, who uses them, and when they are used.

A simple example using an expression by C. E. Shannon will illustrate one reason why Spread Spectrum Systems are used. For the purpose of this discussion (and of particular interest in Spread Spectrum Systems) the noise power is due to narrowband jamming.

$$C = 1.44W \log_e (1 + S/N)$$

Where C = Capacity in bits per second

W = bandwidth in hertz

N = Noise Power due to narrowband jamming or narrowband interference.

S = Signal Power

for small S/N ratio 0.1

$$C = 1.44W (S/N)$$

rearranging

$$(C/1.44) (N/S) = W$$

[1]

For a typical system with an information rate of 4KBPS, and an environment where noise is 100 times greater than the signal, the information must be transmitted in a BW of

$$W = \frac{4 \times 10^3 \times 100}{1.44} = 2.78 \times 10^5 \text{HZ}$$

As can be seen from Equation [1], that for a low information rate for a given N/S, the bandwidth W must be increased.

This increase in bandwidth is obviously, the spreading we've been talking about.

If the noise power was due to white noise with a Power Spectral Density (PSD) of N_0 then one would have $N = N_0 W$ and for small S/N

$$C = 1.44 (S/N_0)$$

which is the limiting factor and one cannot expect to do better than this by increasing the bandwidth.

Some important advantages are enabled by Spread Spectrum Systems. The order of preference would be dependent on the user and application. See Table 1.

The properties in Table 1 are a result of the large bandwidth and of the pseudorandom code used to modulate the information.

The area that Spread Spectrum Systems encompasses is so vast, exciting, and filled with numerous applications. The application of selective addressing is described by the following scenario.

A military environment consisting of a ground base, air fleet of some bombers, helicopters, fighters, naval fleet of carriers, destroyers, escorts, etc.

The fighters want to talk to the carriers about landing while the bombers are receiving information from the ground base on a target. Using selective addressing this is easily accomplished.

| SPREAD SPECTRUM SYSTEM | PROCESS GAIN |
|------------------------|--|
| DIRECT SEQUENCE | $\frac{BW_{RF}}{R_{info}} = TW$ |
| FREQUENCY HOPPING | $\frac{BW_{RF}}{R_{info}} = TW = \text{NUMBER OF FREQUENCY CHOICES}$ |
| CHIRP | $\text{COMPRESSION RATIO} = tdF = TW$ |

Table 1 Process Gains

Of course, most of the advantages are seen to be important to the military; they are becoming more and more useful to Industry.

Code division is possible for multiple access by many users. An office systems might use this type of set-up.

Interference rejection may be needed due to natural or man made disturbances, due to buildings, mountains, etc.

Since the signal power is spread over a wide band, the low-density power spectra in any small bandwidth is small. Therefore, Spread Spectrum Signals are perfect for signal hiding or low probability of intercept (LPI) communications. Again, a very important aspect in military communication systems.

In concluding the what, why, when and who's of Spread Spectrum Systems we leave knowing that a Spread Spectrum Systems expands the bandwidth of a signal, transmits the expanded signal and recovers the desired signal by remapping the received Spread Spectrum Systems into its original spectrum. We also note that there has been a trade of increased bandwidth for the purpose of error-free information in an environment where narrowband jamming is present.

When designing Spread Spectrum Systems for use in a noisy or jamming environment it is necessary to take into consideration the losses of the system, and a useful system output signal to noise ratio.

Jamming margin is the term in a systems specification that relates the above to the processing gain of the system.

$$\text{Jamming Margin} = \text{Processing Gain} - [L_{\text{system}} + (S/N)_{\text{output}}]$$

In a Spread Spectrum Receiver, if the received signal is in phase with the local reference signal the desired signal shall collapse to its original bandwidth before spreading. Any unmatched signals such as jamming is spread by the local reference to its bandwidth or more. A filter then rejects all but the desired narrowband signal. Hence the Spread Spectrum Receiver enhances the desired signal while suppressing the unmatched signals (jamming, noise). This enhancing is known as the "Process Gain".

The processing gain which is developed from a sequential signal bandwidth spreading and despreading process can be estimated by the simple rule of thumb.

$$\text{Processing Gain} = \frac{BW_{RF}}{R_{info}}$$

Where the BW_{RF} is the bandwidth of the transmitted Spread Spectrum Systems and R_{info} is the information rate of the baseband signal.

DIRECT SEQUENCE SYSTEMS

Of the Spread Spectrum Systems in use, the best known and most widely used is the Direct Sequence Systems.

The reason Direct Sequence Systems are in such wide use is due to their relative simplicity. They are simple in the sense of their hardware requirement.

Specifically, these systems do not require a high speed, fast-settling frequency synthesizer. The latter being required in Frequency Hopped Systems.

As a result of the above, it is likely that Direct Sequence Systems will continue to be very popular and commercial applications of such systems will also be evident in the foreseeable future.

The intent of this Thesis is not to give an in-depth look at every aspect of Direct Sequence Systems, but for the purpose of background information, it shall briefly mention some aspects or characteristics of Direct Sequence Systems.

A Direct Sequence Systems as mentioned earlier is modulation of a carrier by a code sequence. In general, the format may be any type of amplitude or angle modulation, but 180° biphase shift keying is very common. Figure 2 shows a typical Spectrum for a 180° biphase modulated carrier.

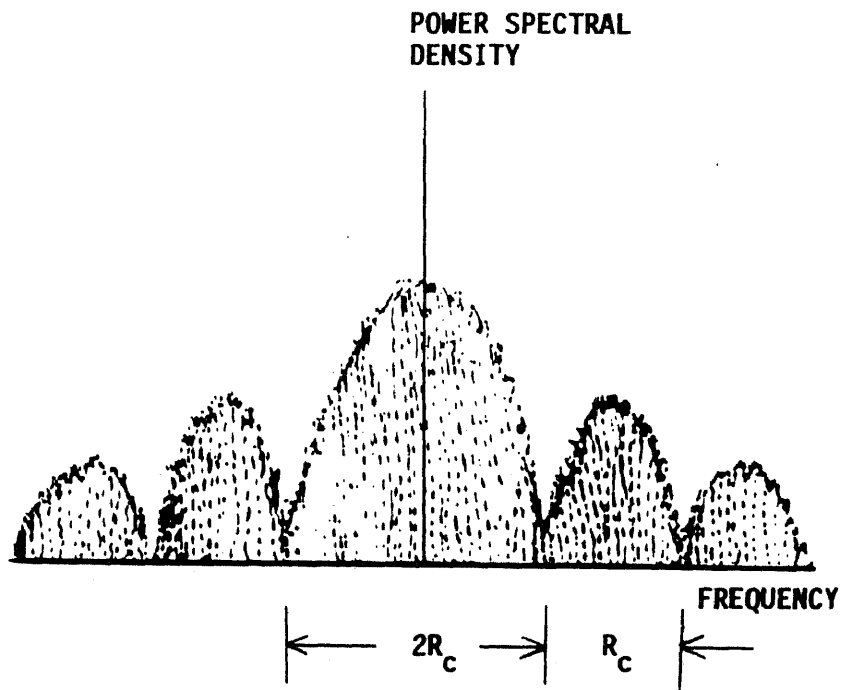

Where R_c equals the chip rate.

**Figure 2 A Typical Spectrum of a
180° Biphase Modulated Carrier**

As seen in the figure, the mainlobe null to null bandwidth is equal to twice the clock rate of the code sequence, and the sidelobe null to null bandwidth is equal to the clock rate of the code sequence.

The suppressed carrier which is a result of 180° biphase modulation and the constant envelope level (so that the transmitted power efficiency is maximized for the bandwidth used) are some reasons why this type of modulation is the most common form of modulation in Direct Sequence Systems.

The Block diagram in Figure 3 illustrates a typical direct sequence Spread Spectrum System. In the receiver, the received signal plus noise (intentional or non-intentional) enters the mixer and the following processes happen, assuming synchronization between the received signal and the local code generator.

The received Direct Sequence Signal is remapped into its original spectrum (carrier bandwidth) while the unsynchronized signal (noise) is spread into a bandwidth equal to its own bandwidth, plus the bandwidth of the code reference.

The system information bandwidth shall determine the postcorrelation filter bandwidth, thereby determining the amount of power from any unsynchronized signals. Hence the processing gain mentioned previously is realized.

Due to the nature of Spread Spectrum Systems requiring wide RF bandwidths, some statements shall be made in regard to this topic.

The obvious reasons for desiring a large RF bandwidth are to reduce the amount of power transmitted per hertz, and for maximum process gain for the purpose of interference rejection.

A not-so desirable effect is the sidelobe energy, which may be high. In Direct Sequence Systems, where other systems operate in the same or adjacent channels, the sidelobe energy can contribute interference.

To combat this problem, different types of modulation schemes may be used, a comparison of Direct Sequence Waveforms is shown in Table 2 . It can be readily seen that in Direct Sequence Systems, the mainlobe bandwidth is a function of the waveform and code rate used.

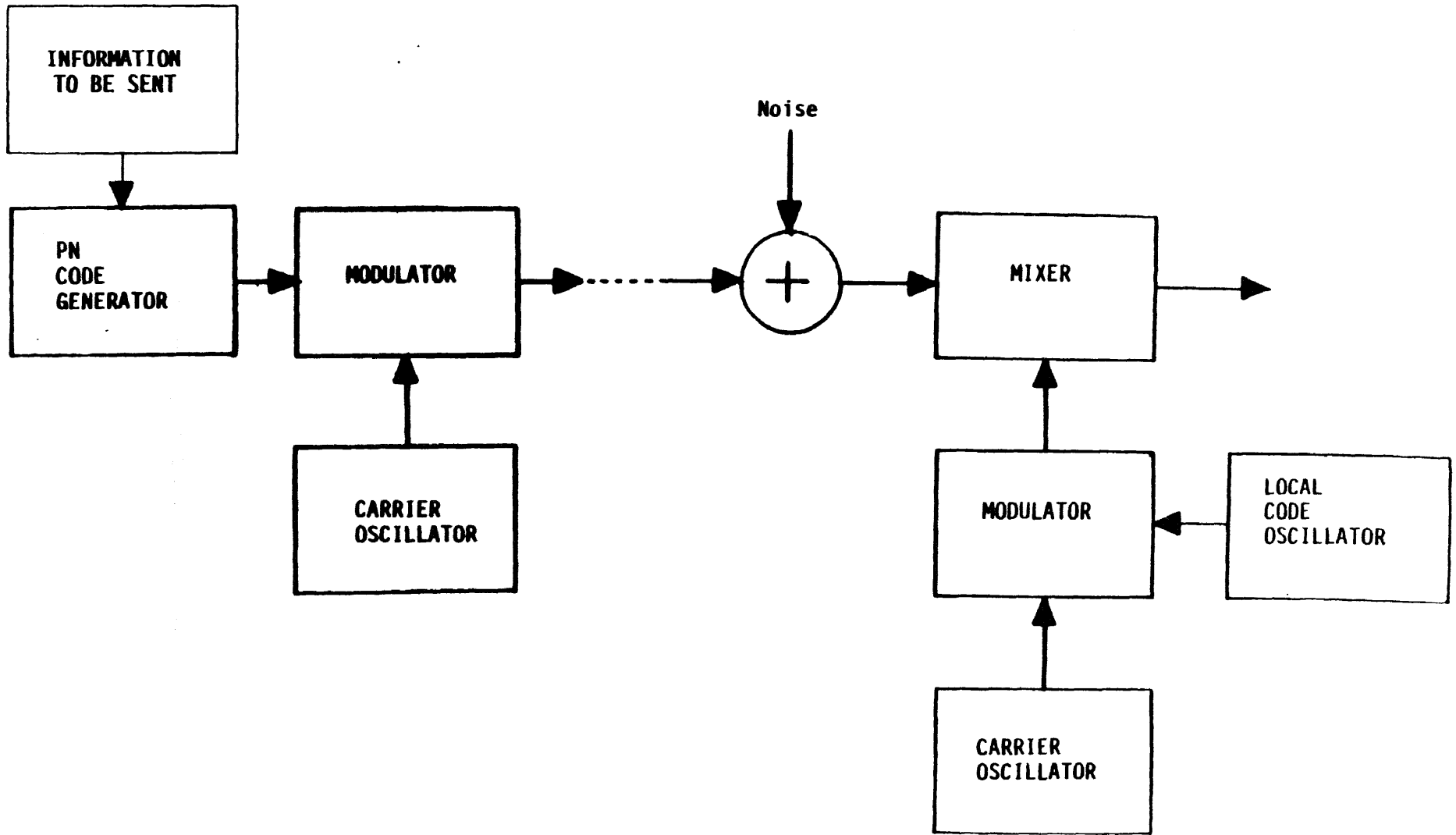

Figure 3 Block Diagram of a Direct Sequence Spread Spectrum System

| WAVEFORM | MAIN LOBE BW | 3-dB BW | SIDELOBE | ROLLOFF RATE |
|----------|------------------|-------------------|----------|--------------|
| BPSK | 2 x code clock | 0.88 x code clock | -13 dB | 6dB/octave |
| PAM | 2 x code clock | 0.88 x code clock | -13 dB | 6dB/octave |
| QPSK | 2 x code clock | 0.88 x code clock | -13 dB | 6dB/octave |
| MSK | 1.5 x code clock | 0.66 x code clock | -23 dB | 12dB/octave |

Note: The bit rate is to be kept the same.

Table 2 Comparison of Direct Sequence Waveforms

It should be mentioned that although 10% of the signal power is lost due to rejecting the sidelobe energy, much of the harmonic power is contained in the sidelobes.

By restricting the sidelobes, the rise and fall times of the modulating code are also restricted, and the effect is rounding of the waveform.

In turn the triangle correlation function of the coded signal becomes rounded. In ranging systems this would have an effect on the range resolution, due to the inability to measure timing precisely.

As mentioned previously, the process gain is dependent on the RF bandwidth. If the RF bandwidth is increased, by increasing the code rate, the process gain shall increase. Another method of increasing the process gain is to reduce the data rate.

At a first glance it might seem that the process gain can be increased indefinitely. However, there are practical limits and some problems that bound the process gain.

The data rate can be slowed down to the extent that the user is willing to transfer data and by the stability of the transmission link. The code rate is limited by the technology of circuits that can generate high speed codes and operate error free for hours, and even days.

A typical process gain limit might be 69dB^1 for Direct Sequence Spread Spectrum communication systems.

As seen in previous figures, the spectrum of a Direct Sequence Spread Spectrum Signal is of a $\left[\frac{\sin x}{x}\right]^2$ form.

A linear maximal sequence is a code sequence which is the longest sequence that can be generated by a linear feedback generator. The pseudonoise code is actually a series of variable duration pulses ranging from one code clock chip to n chips for a linear maximal sequence of $2^n - 1$ bits.

1. "Spread Spectrum Systems", 2nd edition, Robert C. Dixon;
A. Wiley Interscience Publication.

For linear maximal sequence, the number of pulses with a duration of one code clock chip is generally one fourth the total number of pulses.

Since the code sequence that is used to modulate a Direct Sequence System is made up of pulses and the fourier transform of a pulse is a

$$\left[\frac{\sin x}{x} \right]$$

function. Therefore, it can be seen why the power spectrum is of the

$$\left[\frac{\sin x}{x} \right]^2 \text{ form.}$$

Also since one code clock chip is the shortest duration pulse, it is equal in length to the code sequence clock period. Hence the width of the mainlobe corresponds to twice the code clock rate.

INTRODUCTION TO ACQUISITION

In my opinion the process of Acquisition has been and will most likely continue to be the area of Spread Spectrum Systems that government and industry spend the most time and money researching and developing.

There are many reasons why in my opinion the above statement is true, but I will touch on some key factors. Since communication systems of this type are usually for military communication systems, and the government needs better and better systems, (by this I mean faster, more secure, harder to jam, less chance of errors) they continue to invest time and money into researching and developing methods of acquisition.

In industry, as different applications for Direct Sequence Spread Spectrum Communication Systems develop, the need will also develop for different acquisition systems. This need may be due to efficiency, cost effectiveness, time, etc.

Acquisition is a process that searches through a region of time-frequency uncertainty and determines whether the locally generated code and the incoming code are closely enough aligned (usually within 1/2 chip).

Without successful acquisition, the information that is being transmitted cannot be successfully received. Therefore acquisition of a system is vital to the system.

Take for example the following two systems. In System One, the transmitter and receiver are said to be fixed in location, and no multipath propagation occurs. Assuming the receiver has knowledge of the code sequence only, here is what would happen in the receiver.

The received signal is multiplied by the locally generated code sequence which is out of phase with the incoming code sequence. This being the case, the output of the multiplier is actually another spreading process. The received signal is spread further by the local code generator.

If the conditions of the second system were the same as those of the first except that the local code generator is in phase (or aligned) with the received signal, the Spread Spectrum Signal will collapse back to the original spectrum signal. Hence the importance of the acquisition process.

It is not enough that a system be able to acquire, but once it acquires synchronization, it must be able to maintain synchronization. The process of maintaining synchronization is called tracking.

Another area of importance in acquisition is the methods of evaluating or comparing different acquisition systems. The methods used for evaluation are the performance characteristics. One of the most important of these characteristics is the mean time to acquire, \overline{T}_{ACQ} .

This time depends on the type of acquisition system used, and also the application. Generally it is desirable that the mean acquisition time be as small as possible.

One reason, and an important one at that, for having the mean time to acquire be as small as possible is the obvious. The more time that passes, the more information that is "lost", assuming the system transmits information without knowledge that the system receiving is not synchronized. Also, and more importantly, is that tactical communication systems are comprised of systems that are bursty, and must synchronize instantly, or they can miss a transmission.

Many applications of Direct Sequence Spread Spectrum Systems are in use today. The following describe some systems that are in use:

SPACE SYSTEMS

Spread Spectrum methods have been proven effective in space systems, especially communication satellites. The main purpose for using Spread Spectrum Systems is for reducing interference.

AVIONIC SYSTEMS

By far the most interesting to me, has a major unique consideration. This unique element is the large and unpredictable range of doppler frequency offsets. Avionic Systems have received heavy Spread Spectrum emphasis. Several systems have been in use or are currently under development. Some examples are the ARC-50, the oldest, produced in early 1960's, Have Quick, and JTIDS.

Other applications include test systems, test equipment, and also position location systems.

Due to the wide range in applications, there is a need for a range in systems, and performance parameters, and criteria for optimum results. Hence many methods of acquisition systems have been, and are being developed. Some acquisition methods may be combined, or modified, again, depending on the particular application.

Acquisition systems may work well in one environment and possibly not at all in another. To illustrate how different applications require different acquisition schemes, the following example shall be used:

A specification requires that the Spread Spectrum System operates in a SNR of -30dB. A sequential estimation system would be a terrible choice for this SNR, yet for a SNR of -5dB, a sequential estimation system may be fine.

This Thesis investigates a number of acquisition systems and compares, characterizes, and discusses the advantages and disadvantages associated with them. It also investigates useful parameters and models of some of the systems.

In the second major section, one of the previous methods will be investigated in detail. Analytic results shall be derived.

In the third major section, the systems described in section two will be simulated, and analyzed on a computer. The results shall confirm the analytical results of section two.

SURVEY OF ACQUISITION TECHNIQUES

SLIDING CORRELATOR

As the name indicates, a received code and the local reference code slide into phase with one another.

A typical flow diagram of this process is shown in Figure 4. With no aprior information, the code clock of the receiver starts out at a predetermined rate, and an unknown area of the uncertainty region. The searching rate or the rate of sliding through all of the possible code-phase offset positions is upper bounded by the ability of the receiver to recognize Sync. This is limited in response time by the bandwidth of the systems postcorrelation

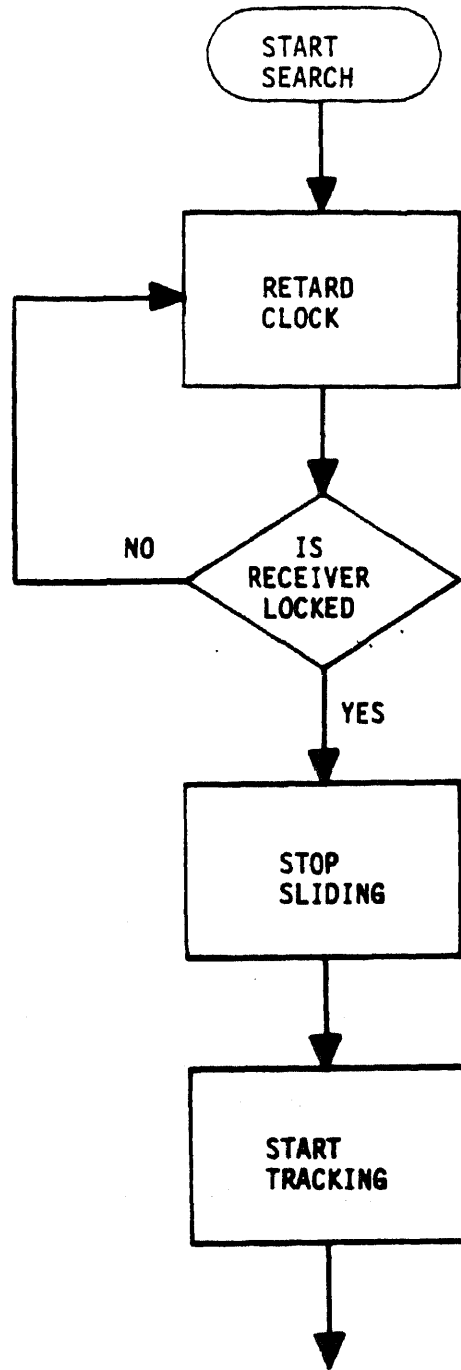

Figure 4 Typical Flow Diagram of Sliding Correlator Process

receiver. By the rise time BW rule and since the correlation function is two chips in width, it is easily seen that the maximum search rate is $2/T_r$

$$\text{where } T_r = .35/BW$$

Spread Spectrum Systems employ long codes, so that the PN principles hold; shorter codes, when multiplied by interference, tend to produce correlations which are not noise-like at all. See Figure 5.

The longer these codes are the greater the uncertainty region. Consider as an example, a 32 register length, Direct Sequence Spread Spectrum System, employing maximal sequences, $2^{32}-1$ chips.

It is therefore possible for a receiving code sequence to be offset by about 4.29 billion chips. We can see that it is possible that hours, days, or even years, might be consumed in initial sync.

This brings us to the disadvantages of the sliding correlator: 1) when a large degree of uncertainty is encountered, examination of all the possible code phase positions is impractical, because of the time involved. It is for this reason that sliding correlators are usually implemented with other schemes. The primary advantage of this system is its simplicity. All that is required is in some way on command, of shifting the code clock of the receiver to a different phase.

When compared to a maximum likelihood technique, the sliding correlator exhibits shorter acquisition time. This can intuitively be realized, remembering that in a maximum likelihood system, a definite decision will be made after examination of all the code phase positions. However, in the sliding correlator, synchronization is determined by the crossing of a threshold by the output of the detector. Therefore the search can terminate at any point within the uncertainty region when the threshold becomes exceeded.

Another interesting comparison is with WARD'S² Sequential Estimation Technique. The serial search (sliding correlator) will yield shorter acquisition times for input S/N less than approximately -15dB.

2. "Acquisition of Pseudonoise Signals by Sequential Estimation", R. B. Ward; IEEE Trans. Commun., Com-13, pp. 475-483, Dec., 1965.



SHORT CODE



LONG CODE

Figure 5 Comparison of Cross-Correlation of Short and Long Code Sequences with a CW Signal

SEQUENTIAL ESTIMATION

The basic principle of this type of system is estimating the present state of an incoming PN stream by examining a small number of input bits. (See Figure 6.)

The incoming coded signal is demodulated (coherently) and the data (code) is inserted into the receiver's own sequence generator, thus defining an initial condition.

One of the properties of a PN sequence is that the next combination of register states depends only on the present combination of states.

Suppose one has a five bit register and attempted to load the registers with the received code, and then tried to acquire the signal. (See Figure 6). When the first code bit is received it is loaded into register 1. Then the second code bit received is loaded into register 1, and register 1 shifts into Register 2, and so on until all 5 registers are loaded.

At this point, it is noted that the first bit received is in register 5 and the fifth bit received is in register 1. In order for the local and received signal to be in sync, the local code generator must stop the loading, and race ahead by $5 + K$ bits. Where K equals the processing delay time in seconds times the code clock rate in bits/sec. For an N register system one has:

$$N + T_p f_k \text{ bits}$$

$$\begin{aligned} T_p &= \text{Processing delay time} \\ f_k &= \text{code clock rate} \end{aligned}$$

After looking at the processes of the system, one can see that this method would expect to yield rapid acquisition with an T_{Acq} close to $N/f_k + T_p$. Of course, this all depends on the ability to make accurate estimations of the initial states of the registers which depend strongly on the SNR among other things. WARD³ has shown a time improvement of a factor of 23 for replacing a sliding correlator with a sequential estimator. This method offers an improvement over the serial search for SNR's down to -15dB.

3. "Acquisition of Pseudonoise Signals by Sequential Estimation", R. B. Ward; IEEE Trans. Commun., Com-13, pp. 475-483, Dec., 1965.

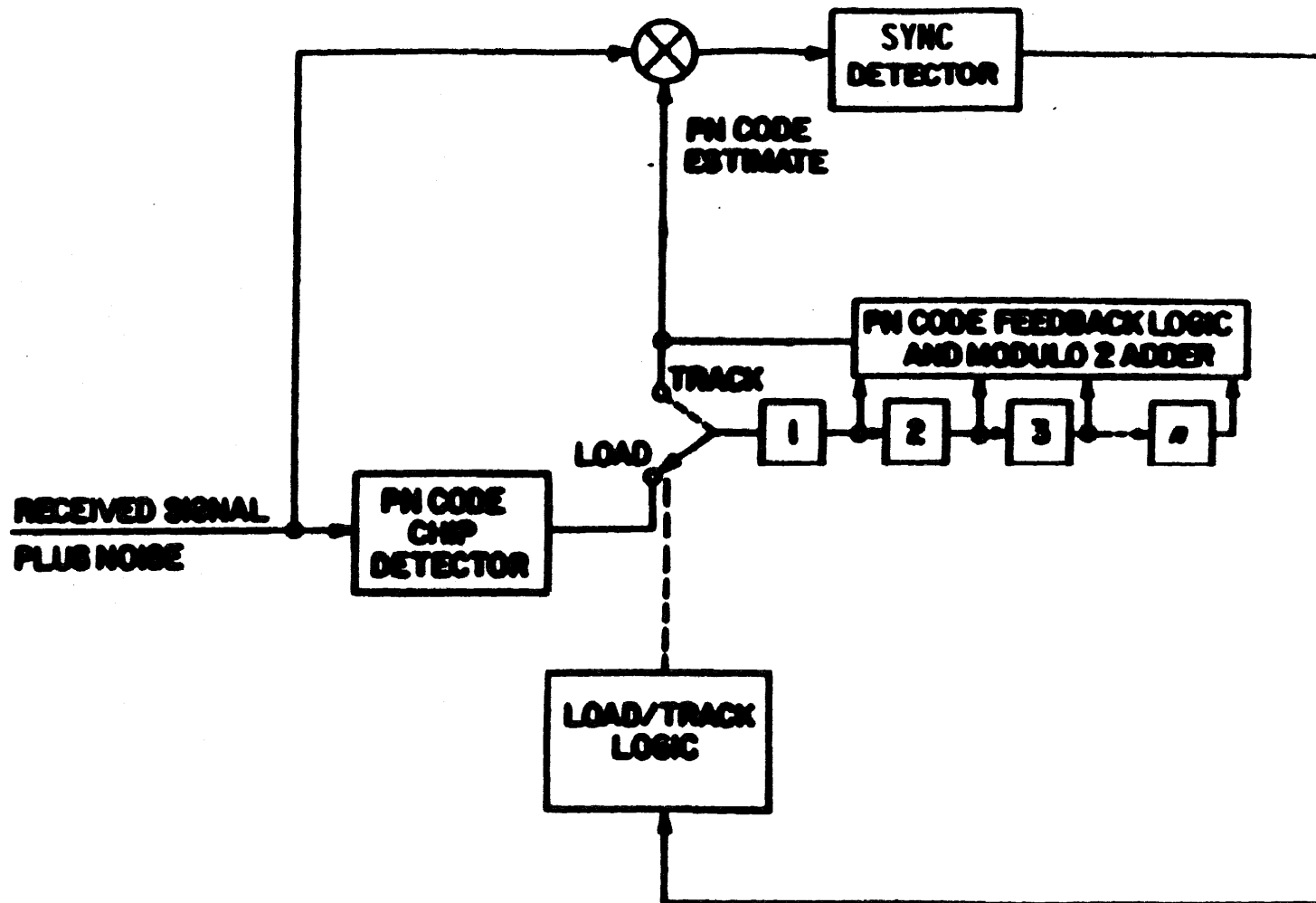

Figure 6 Block Diagram of Sequential Estimator System

The major draw back of Sequential Estimation is its vulnerability to interference, since the demodulator demodulates the code received without the benefit of the processing gain.

When the interference is strong, the receiver will try to acquire the interference. Thus sequential estimation is not useful for multiple access, or in tactical radio environments characterized by bursty communications or severe jamming.

However, sequential estimators find use in precision ranging or continuously operating strategic links. Sequential estimation is also attractive in systems that deal only with natural disturbances.

THE SINGLE DWELL SERIAL PN ACQUISITION SYSTEM

This method of acquisition is based on a variation of time difference between the incoming and local PN waveforms. The local PN code is advanced (or retarded) by a fixed amount (usually a fraction of a chip) at uniform increments in time. In effect, a sweep of the uncertainty region from one end to the other shall be performed.

Take a look at Figure 7. Here is what happens:

- A) The timing epoch of the local PN code is set, and the locally generated PN signal is correlated with the received signal plus noise.
- B) At this point, one of two events can take place:
 - 1. The two signals are not in alignment and the output of the correlator would actually spread the signal.
 - 2. The two signals are in alignment. If this is the case, one would have the despread spectrum.

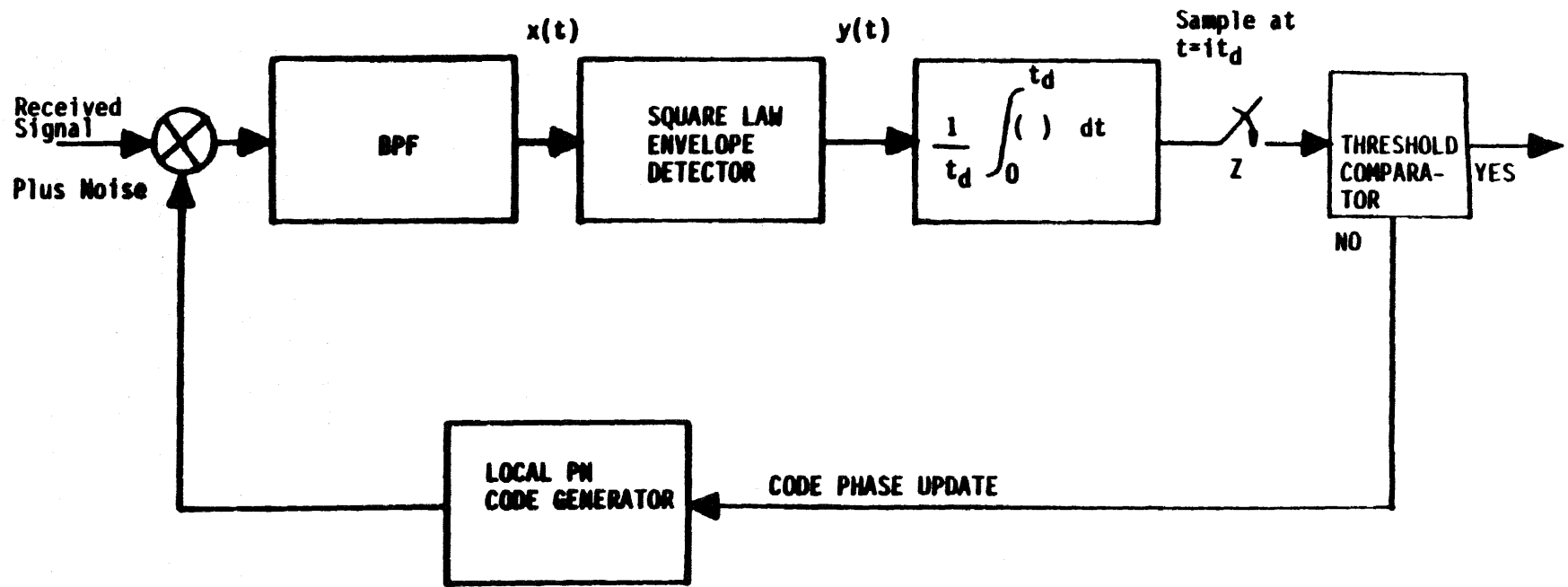

Figure 7 Block Diagram of a Single Dwell PN Acquisition System

The envelope is extracted and integrated for a time t_d , the dwell time. At fixed examination intervals, which are long compared to a chip duration, the integrator output is compared to a threshold. Based on the level, a decision is made to whether the two codes are in synchronization.

If the threshold is not exceeded, the search control inhibits a clock pulse to the PN generator, so that the local code phase slips to the next cell (usually one-half chip) and the process is repeated.

When the incoming and local PN sequences are in course alignment, the threshold will be exceeded with high probability, and the local PN code will not be slipped. It will remain in the same phase relative to the incoming signal. The search will then be stopped, and tracking will be initiated.

MATCHED FILTER SYNCHRONIZERS

A matched filter is a device that generates a time reversed replica of the desired signal when its input is an impulse. As TURIN⁴ states, "The transfer function of a matched filter is the complex conjugate of the signal to which it is matched."

Matched filters that are used on the front end of receivers tend to be surface acoustical wave (saw) type. Saw matched filters are passive devices, generally made up of delay elements. The longest acoustical matched filter consists of a series of short lines that reach a total of 4000 chips.

A typical delay line matched filter is illustrated in Figure 8.

The matched filter is designed to recognize a particular sequence, or for that matter, a part of the sequence. Each delay element is required to have a delay that is equal to the period of the expected code clock.

Due to the above requirement, each element will contain the energy corresponding to one code chip at any one time.

4. "An Introduction to Matched Filters", G. L. Turin; IRE Trans. Info. Th., June, 1960.

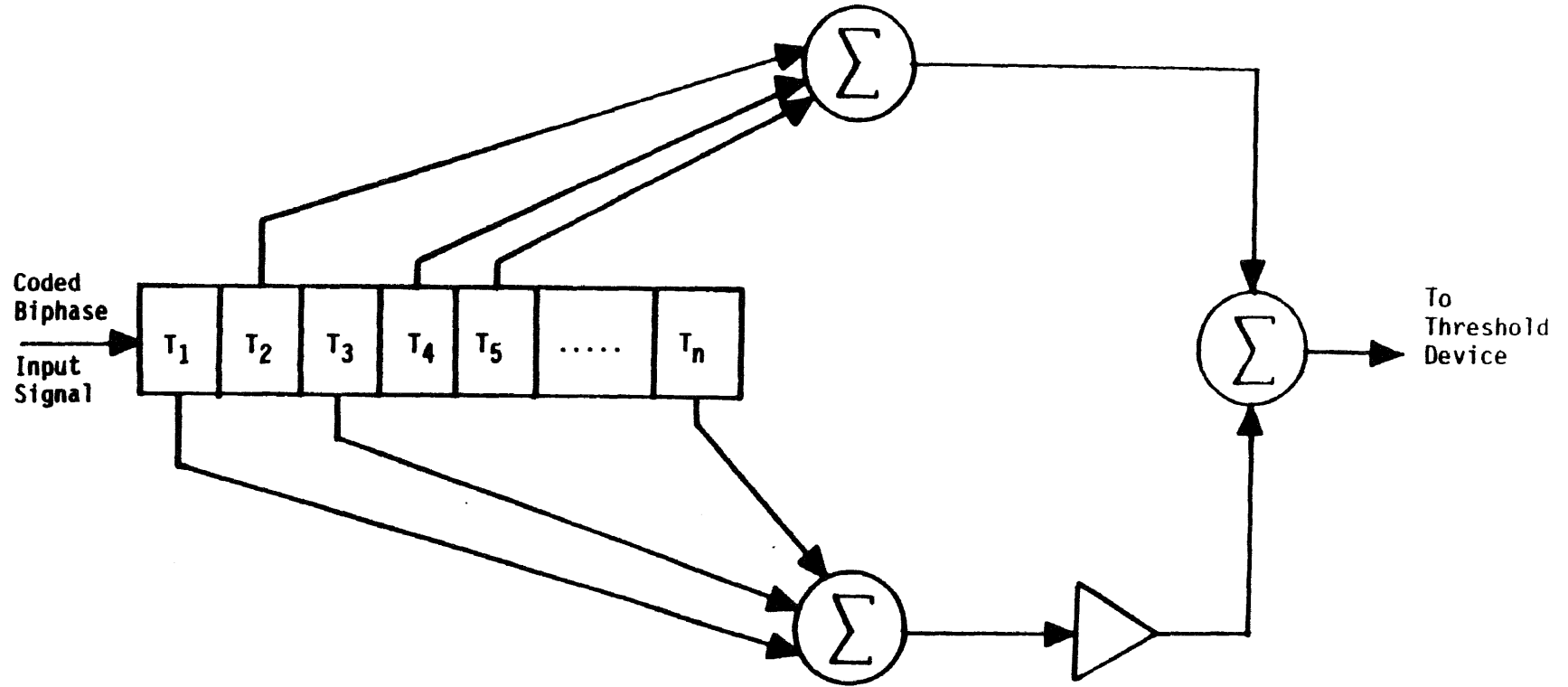

Figure 8 A Typical Delay Line Matched Filter

The total output is n times greater than the unprocessed output. This output is then put into a threshold device and if threshold is exceeded, a predetermined code generator state can be started, and correlation can follow.

As one increases the number of delay elements n , the signal enhancement offered by this technique also increases, G_p (delay line matched filter) = $10 \log n$. However, for 100 MCPS codes, G_p is limited to approximately 36dB for production length range of 20- 40msec.

When designing the delay elements of the matched filter it is very important that the delays accurately represent the clock period of the code sequence to be detected. When accurate representation is present, the signal summation is perfect. On the other hand, when the signals are mismatched, there is overlapping into adjacent elements.

UNIVERSAL TIMING

An interesting technique in use primarily in satellite communications, is that of Universal Timing. The idea is when accurate, dependable universally known time is available it can use that information to set all code generators to predetermined states. Of course, it is possible due to propagation delays, for the received signal and locally generated signal to be offset, therefore some sort of Search-and-Track capability is needed.

The use of the Universal Timing concept is used often in satellite communication systems, since accurate distance information is known and therefore the search process can be minimized.

The future looks very bright for this concept employed in mobile use, especially as more accurate and stable frequency sources and computerized position estimation methods are developed. The computerized position estimation methods can provide more accurate information for range compensation.

As one can see, there are many ways of acquiring synchronization in Direct Sequence Spread Spectrum Systems. Each of these methods have strong points and weak points. The following two methods are grouped together because they are basically similar. The first makes use of a special coding for sync acquisition, and the second uses synchronization preambles, which are primarily short special codes.

SPECIAL CODES

The ever so important need for rapid acquisition of Spread Spectrum Systems brought about the use of special codes for the specific purpose of more rapid sync acquisition.

As stated previously, the types of acquisition processes along with their performance characteristics, etc., depend on the application. With this in mind, let's talk about the Jet Propulsion Lab (JPL) component code.

The JPL component code is the best-known easily acquirable type. The component code is composed of several shorter codes, each of different length. These shorter codes, when combined, result in a code with a length $(2^m-1)(2^n-1)\dots(2^r-1)$, where $m \neq n \neq r$ and a special correlation property.

The special correlation property is different from the correlation property of a maximal linear sequence. In an m -sequence, there is only one point of autocorrelation, where as the component codes have one more correlation property than there are components in the code.

As an example of the synchronization process in a system employing a JPL code consisting of 3 component codes with say $(2^m-1) = 300$, $(2^n-1) = 700$, $(2^r-1) = 1000$ chips. (From this m , n , and r are approximately eight, nine, and ten respectively). The following can be seen.

Synchronization is accomplished by cross-correlation of one of the component codes with the composite code. A partial correlation will occur when the component code reaches synchronization with its partner, within the composite code. The partial correlation is the signal to start the next component code cross-correlation. The above process is repeated until all component codes are synchronized with their respective counterparts within the composite.

When this occurs, the correlation is the same as if the process had simply synchronized the composite code. The main advantage is that this process provides rapid acquisition without the use of a preamble or anything besides the composite code. With component codes of the above, a search totaling 2000 chips can be accomplished much quicker than that of $2^{m+n+r} = 1.34 \times 10^8$ chips.

It should go without saying that there are disadvantages also. The major disadvantage is there is a decrease in SNR in the correlator output, when all code components are not locked. Therefore this would not likely be used in an environment where there is substantial interference.

One of the most effective methods that make use of a sliding correlator are synchronization preambles. They are special code sequences short enough to allow search through all possible code positions in some reasonable time, but they are limited to how short they may be by correlation properties. Another factor which influences length of the preamble, are interference rejection requirements.

One idea on the use of synchronization preambles is to send one at the beginning of each transmission (for example push-to-talk operation). This would allow operation when knowledge of range, speed and/or direction is unavailable.

The major disadvantages come about from the major advantage of the preambles being short. The disadvantages stated simply are: the acquisition process is more vulnerable to false correlations and to possible reproduction by a would-be interferer.

TRANSMITTED REFERENCES

When reflecting on the different methods of sync acquisition, one notices similarities and/or modifications of methods. The systems that follow are similar in the sense that they use information that is transmitted, to acquire sync.

In the event that the receiver must be the simplest possible, a good choice is to utilize the transmitted reference system. This system minimizes the hardware needed in the receiver, since a local code generator, search or tracking circuits or any code related mechanisms are not required. Thereby reducing complexity, cost, weight and size of the receiver.

Operation of a transmitted reference receiver is quite simple. (See Figure 9 .) The local reference generated in the transmitter is sent to the receiver along with the signal to be demodulated. The carrier frequencies are offset by an amount equal to the 1st IF in the receiver. When the two signals are mixed, a correlated IF is produced.

If the system is to be used in an environment of active jamming or interference, precautions must be taken since any two frequencies that differ by the frequency of the IF will cause false synchronization.

Another disadvantage is that noise is introduced in the transmission process, which degrades the performance of the receiving system.

When simplicity of the receiver isn't a big factor, a system that provides rapid access to a direct sequence signal is a process called burst synchronization.

The concept of burst synchronization is to transmit a short, high speed message. The message contains only code and/or carrier sync. The information that is to be transmitted follows a switch to direct sequence.

The high peak power available to a low duty cycle burst transmitter would cause a would-be jammer to require an inordinately large amount of continuous RF power to jam. Therefore, this system is also useful when there is interference or jamming.

THE MULTIPLE DWELL SERIAL PN ACQUISITION SYSTEM

The Multiple Dwell System is a generalized single dwell system. The Multiple Dwell System offers additional threshold testing, each with its own dwell

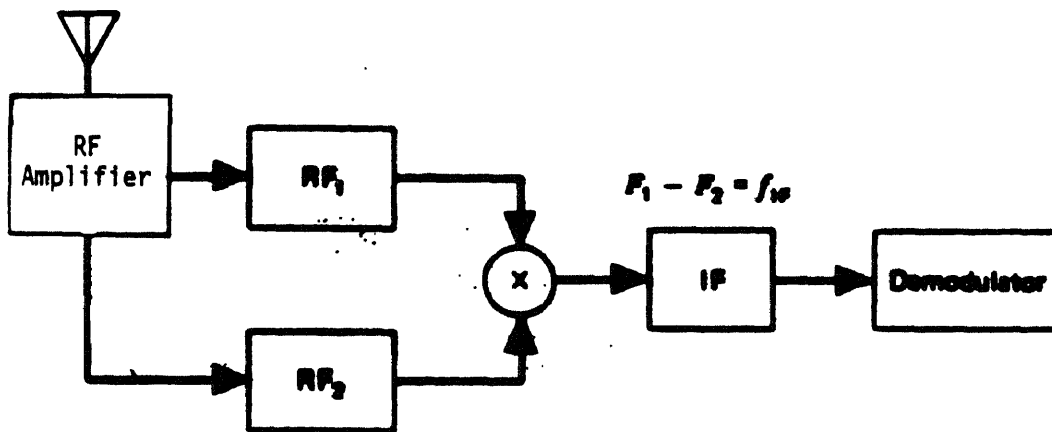
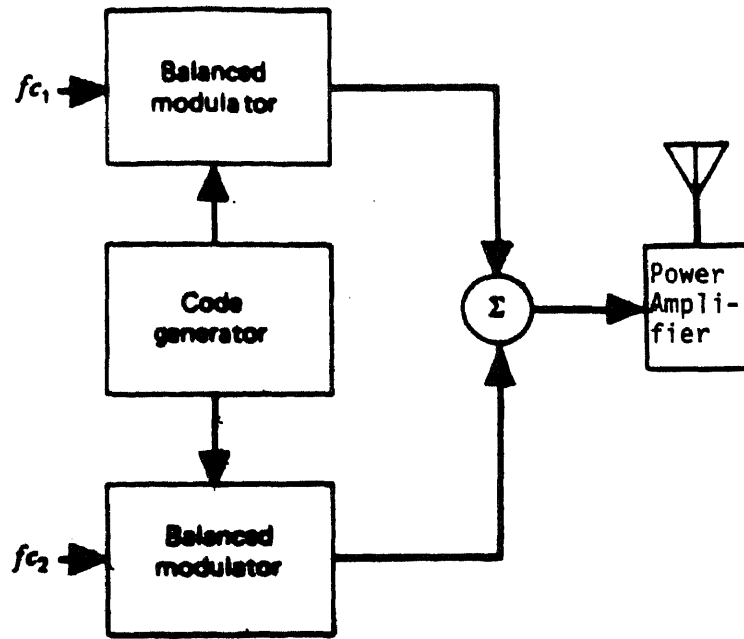

FIGURE 9 TRANSMITTED REFERENCE SYNCHRONIZATION METHOD

time, over the examination interval. After each dwell time, a decision is made whether to continue with the next integration (dwell time) or to update the code phase.

Many Spread Spectrum Systems employ long codes, and therefore most cells searched correspond to incorrect alignments. Using a Multiple Dwell System, a misalignment will quickly be identified and dismissed, compared to the single dwell, which must wait until the entire dwell period has been examined.

A block diagram of an N-dwell time PN acquisition is shown in Figure 10.

All N integrate and dump circuits start at the same time, and begin integrating for their individual dwell periods. The dwell periods are such that:

$$t_{d1} < t_{d2} < t_{d3} \dots < t_{dn}$$

At $t = t_{d1}$, the first dwell period is completed, and the output of the integrate-and-dump circuit is sampled.

A threshold comparison is made, and if it is exceeded, it will initiate the 2nd integrate-and-dump circuit to be sampled at time = t_{d2} . The process is repeated as necessary, until either all thresholds are exceeded, this meaning verification of alignment, or until a threshold is not exceeded.

In the latter case, a signal will cause the local PN code generator to update the phase, and reset all integrate dump circuits.

In reality all the individual integrate-and-dump circuits would be replaced by a single continuous time integrator whose output is sequentially sampled, not dumped, at $t = t_{d1}, t_{d1} + t_{d2}, \dots, t_{d1} + t_{d2} \dots t_{di}$ depending on the outcomes of the first $i-1$ threshold comparisons. The integrator will be reset only after a decision has been made to update the code phase.

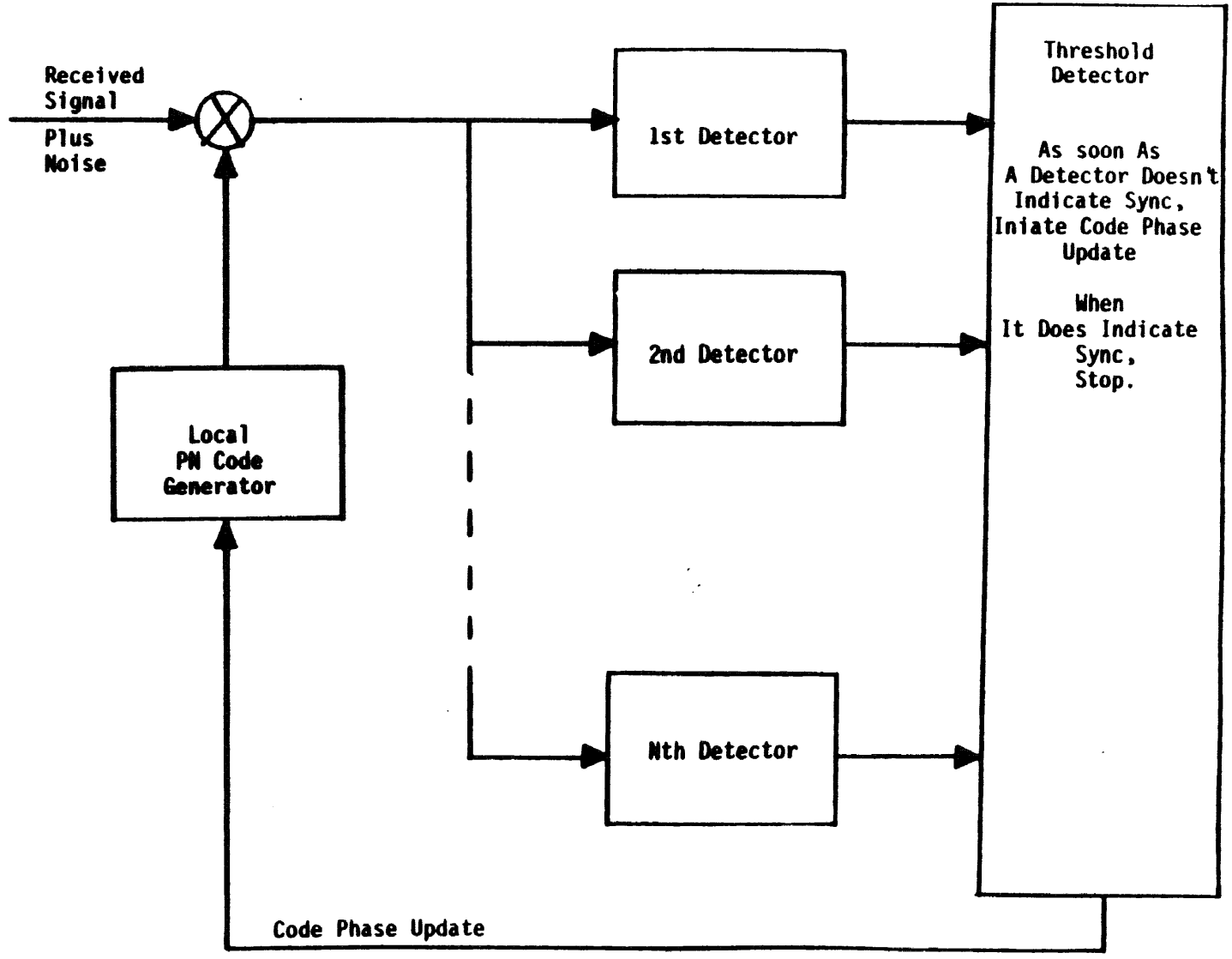

FIGURE 10 BLOCK DIAGRAM OF N-DWELL PN ACQUISITION SYSTEM

If for some reason all thresholds are exceeded, and verification is initiated when in fact the incoming signal and the local code replica are not in phase, one must characterize the penalty time T_p for false alarm.

It is convenient to model T_p as an integer multiple of the additional time required by the N-th dwell,

$$T_p = K_N (t_{dN} - t_{d,N-1})$$

ANALYSIS OF SINGLE DWELL SERIAL PN ACQUISITION SYSTEM

I prefer to use the following method for determining the mean and variance of the acquisition time because it allows one the benefit of seeing how false alarms effect the mean and variance of the acquisition time.

The following assumptions are made for this derivation:

1. No aprior knowledge of the correct cell's location within the total uncertainty region is available.
2. A cell by cell search of the entire uncertainty region is repeated until the correct cell is detected.

Calculation of the mean and variance of the acquisition time

Calculation of mean acquisition time for $P_{FA}=0$ and P_D = constant.

Definitions: P_D = Probability of Detection
 $1-P_D$ = Probability of no detection has occurred
 P_{FA} = Probability of a false alarm
 K = The particular search of the uncertainty region during which the correct cell is first detected.

The probability density function of K can be seen to be the geometric probability density function

$$P(K) = P_D (1-P_D)^{K-1} ; K = 1, 2, 3 \dots$$

As a result of the $P_{FA} = 0$, the detection probability for each complete search of the entire uncertainty region is equal to the detection probability for the correct cell, that is P_D .

To calculate N_u' , the number of cells searched without success of detection prior to the K th search during which the correct cell will be detected, simply multiply the number of unsuccessful searches through the uncertainty region by the number of cells passed per search. Thus,

$$N_u' = q (K-1)$$

$$T_u' = N_u' t_d = q t_d (K-1) \quad [2]$$

Equation [2] represents the time expired in passing through the above unsuccessful series of searches.

The mean time, $\overline{T_u'}$, is

$$\overline{T_u'} = E [T_u'] = \sum_{K=1}^{\infty} T_u' P(K) = qt_d \sum_{K=1}^{\infty} (K-1) P_D (1-P_D)^{K-1}$$

PROOF

By making use of the definition of

$$\sum_{K=1}^{\infty} P_D (1-P_D)^{K-1} = 1 \quad [3]$$

and after differentiating Equation [3] one obtains

$$\sum_{K=1}^{\infty} \left[-P_D (1-P_D)^{K-1-1} (K-1) + (1-P_D)^{K-1} (1) \right] = 0$$

$$\sum_{K=1}^{\infty} (1-P_D)^{K-1} = \sum_{K=1}^{\infty} P_D (1-P_D)^{K-1} (1-P_D)^{-1} (K-1)$$

$$\frac{\sum_{K=1}^{\infty} (1-P_D)^{K-1}}{(1-P_D)^{-1}} = \sum_{K=1}^{\infty} KP_D (1-P_D)^{K-1} - \sum_{K=1}^{\infty} P_D (1-P_D)^{K-1}$$

$$\sum_{K=1}^{\infty} KP_D (1-P_D)^{K-1} = \sum_{K=1}^{\infty} (1-P_D)^{K-1} (1-P_D) + \sum_{K=1}^{\infty} P_D (1-P_D)^{K-1}$$

$$= \sum_{K=1}^{\infty} (1-P_D)^{K-1} [1-P_D+P_D]$$

$$\sum_{K=1}^{\infty} KP_D (1-P_D)^{K-1} = \sum_{K=1}^{\infty} (1-P_D)^{K-1} = \frac{1}{P_D} \quad [4]$$

After combining Equations [3] and [4] one obtains

$$\overline{T_u} = qt_d \sum_{k=1}^{\infty} (K-1) P_D (1-P_D)^{K-1} = qt_d \left[\frac{1}{P_D} - 1 \right] \quad [5]$$

The mean time of Equation [5] represents the mean time of the unsuccessful series of searches. To calculate the mean time to acquire it is necessary to account for the successful search, the k th search, during which the acquisition process will terminate at the location of the correct cell.

Letting m denote the correct cell location ($m = 1, 2, 3, \dots, q$) the time required to reach the correct cell once the k th search is initiated is thus,

$$T_S = mt_d$$

The probability density function of m is

$P(m) = 1/q$, $m = 1, 2, 3, \dots, q$ since it is equally likely for the correct cell to be found any of the q cells.

The mean of m , \bar{m} , is readily seen to be

$$\begin{aligned}\bar{m} &= \sum mP(m) = \sum_{m=1}^q m \frac{1}{q} = \frac{1}{q} \sum_{m=1}^q m \\ &= \frac{1}{q} [1+2+3+ \dots +q] = \frac{1}{q} \left[\frac{q(q+1)}{2} \right] = \frac{q+1}{2}\end{aligned}$$

The mean time of a successful search is

$$\bar{T}_S = \bar{m}t_d = \left(\frac{q+1}{2}\right)t_d \quad [6]$$

Finally to obtain an expression for the total acquisition time, T_{acqo} , simply add the time of unsuccessful searches to the time of the successful search, T_u' and T_S respectively.

For the mean we have

$$\bar{T}_{acqo} = \bar{T}_u' + \bar{T}_S$$

and combining Equations [5] and [6] gives the final result

$$\bar{T}_{acqo} = qt_d \left[\frac{1}{P_D} - 1 \right] + \left(\frac{q+1}{2}\right)t_d = t_d \left[q \left(\frac{1}{P_D} - 1 \right) + \frac{q+1}{2} \right]$$

$$\begin{aligned}
&= t_d \left[\frac{(2-2P_D)q + P_D q + P_D}{2P_D} \right] \\
\overline{T}_{acq0} &= \left[\frac{(2-P_D)q + P_D}{2P_D} \right] t_d \quad [7]
\end{aligned}$$

Equation [7] represents the mean acquisition time assuming $P_{FA} = 0$.

Calculation of the variance of the acquisition time for $P_{FA}=0$ and $P_D=Constant$

The variance of the acquisition time will be calculated in a similar manner as the mean of the acquisition time. First the variance of the unsuccessful searches will be calculated and then the variance of the successful search will be calculated.

The variance, σ^2_u , is

$$\sigma^2_u = E \left[(T_u' - \overline{T_u}')^2 \right] = E \left[T_u'^2 \right] - (\overline{T_u}')^2$$

from Equations [2] and [5]

$$\sigma^2_u = E \left[q^2 t_d^2 (K-1)^2 \right] - q^2 t_d^2 \left[1/P_D - 1 \right]^2$$

$$= q^2 t_d^2 E \left[(K-1)^2 \right] - q^2 t_d^2 \left[1/P_D - 1 \right]^2$$

$$\sigma^2_u = q^2 t_d^2 \sum_{K=1}^{\infty} (K-1)^2 P_D (1-P_D)^{K-1} - q^2 t_d^2 \left[1/P_D - 1 \right]^2$$

PROOF

By making use of Equation [4] repeated below for convenience:

$$\sum_{K=1}^{\infty} K P_D (1-P_D)^{K-1} = \frac{1}{P_D}$$

and after differentiating the above one obtains

$$\sum_{K=1}^{\infty} K \left[-P_D (1-P_D)^{K-1-1} (K-1) + (1-P_D)^{K-1} \right] = -\frac{1}{P_D^2}$$

$$\sum_{K=1}^{\infty} -K P_D (1-P_D)^{K-1} (1-P_D)^{-1} (K-1) + \sum_{K=1}^{\infty} K (1-P_D)^{K-1} = \frac{-1}{P_D^2}$$

$$\sum_{K=1}^{\infty} K P_D (1-P_D)^{K-1} (K-1) = \frac{1}{(1-P_D)^{-1} P_D^2} + \frac{\sum_{K=1}^{\infty} K (1-P_D)^{K-1}}{(1-P_D)^{-1}}$$

$$\sum_{K=1}^{\infty} K^2 P_D (1-P_D)^{K-1} - \sum_{K=1}^{\infty} K P_D (1-P_D)^{K-1} = \frac{1}{P_D^2 (1-P_D)^{-1}} + \frac{\sum_{K=1}^{\infty} K (1-P_D)^{K-1}}{(1-P_D)^{-1}}$$

$$\sum_{K=1}^{\infty} K^2 P_D (1-P_D)^{K-1} = \frac{1-P_D}{P_D^2} + \sum_{K=1}^{\infty} K P_D (1-P_D)^{K-1} + \sum_{K=1}^{\infty} K (1-P_D)^{K-1} (1-P_D)$$

$$\begin{aligned}
&= \frac{1}{P_D^2} - \frac{1}{P_D} + \frac{1}{P_D} + \sum_{K=1}^{\infty} K (1-P_D)^{K-1} - \sum_{K=1}^{\infty} K P_D (1-P_D)^{K-1} \\
&= \frac{1}{P_D^2} - \sum_{K=1}^{\infty} K (1-P_D)^{K-1} - \frac{1}{P_D} \\
&\sum_{K=1}^{\infty} K^2 P_D (1-P_D)^{K-1} = \frac{1}{P_D^2} - \frac{1}{P_D^2} - \frac{1}{P_D} = \frac{2}{P_D^2} - \frac{1}{P_D}
\end{aligned}$$

After combining equations one obtains

$$\begin{aligned}
\sigma_u^2 &= q^2 t_d^2 \left[\sum_{K=1}^{\infty} (K^2 - 2K + 1) P_D (1-P_D)^{K-1} - \left(\frac{1}{P_D^2} - \frac{2}{P_D} + 1 \right) \right] \\
&= q^2 t_d^2 \left[\sum_{K=1}^{\infty} K^2 P_D (1-P_D)^{K-1} - \sum_{K=1}^{\infty} 2K P_D (1-P_D)^{K-1} + \sum_{K=1}^{\infty} P_D (1-P_D)^{K-1} \right. \\
&\quad \left. - \frac{1}{P_D^2} + \frac{2}{P_D} - 1 \right] \\
&= q^2 t_d^2 \left[\frac{2}{P_D^2} - \frac{1}{P_D} - \frac{2}{P_D} + 1 - \frac{1}{P_D^2} + \frac{2}{P_D} - 1 \right] \\
\sigma_u^2 &= q^2 t_d^2 \left[\frac{1}{P_D^2} - \frac{1}{P_D} \right]
\end{aligned} \tag{8}$$

The variance of the acquisition time of Equation [8] represents the variance of the acquisition time of the unsuccessful series of searches. To calculate the variance of the acquisition time again it is necessary to account for the successful search, the Kth search, during which the acquisition process will terminate at the location of the correct cell.

The variance of m is as follows:

$$\begin{aligned}
 \sigma_m^2 &= \sum m^2 P(m) - (\bar{m})^2 = \sum_{m=1}^q m^2 \frac{1}{q} - (\bar{m})^2 \\
 &= \frac{1}{q} \sum_{m=1}^q m^2 - (\bar{m})^2 \\
 &= \frac{1}{q} (1^2 + 2^2 + 3^2 + \dots + q^2) - (\bar{m})^2 = \\
 &= \frac{1}{q} \left(\frac{q(q+1)(2q+1)}{6} \right) - \left(\frac{q+1}{2} \right)^2 \\
 &= \frac{(q+1)(2q+1)}{6} - \left(\frac{q+1}{2} \right)^2 = \frac{2q^2+3q+1}{6} - \frac{(q^2+2q+1)}{4} \\
 &= \frac{4q^2+6q+2-3q^2-6q-3}{12}
 \end{aligned}$$

$$\sigma_m^2 = \frac{q^2-1}{12} \quad [9]$$

The variance of the acquisition time of a successful search is:

$$\sigma_s^2 - \sigma_m^2 t_d^2 = \left(\frac{q^2-1}{12} \right) t_d^2$$

The addition of the variance of the acquisition time for unsuccessful and successful searches, Equations [8] and [9] yield the total variance of the acquisition time σ_{acq}^2 ,

$$\begin{aligned}
\sigma^2_{\text{acqo}} &= \sigma^2_u + \sigma^2_s \\
&= q^2 t_d^2 \left[\frac{1}{P_D^2} - \frac{1}{P_D} \right] + \left[\frac{q^2 - 1}{12} \right] t_d^2 \\
&= t_d^2 \left[q^2 \left(\frac{1}{P_D^2} - \frac{1}{P_D} \right) + \frac{q^2 - 1}{12} \right]
\end{aligned}$$

and for $q \gg 1$

$$\sigma^2_{\text{acqo}} = q^2 t_d^2 \left[\frac{1}{12} + \frac{1}{P_D^2} - \frac{1}{P_D} \right] \quad [10]$$

Equation [10] represents the variance of the acquisition time assuming $P_{FA} = 0$.

Effect of Non-Zero False Alarm Probability

The previous results, Equations [7] and [10], assumed a false alarm probability, $P_{FA} = 0$. In the following section, the previous equations shall be modified to incorporate a non-zero false alarm probability.

After K searches the total number of cells searched is equal to $N_u' + m$. One shall note however that during each search of the uncertainty region at most one cell is correct. Therefore K cells are correct for K searches and there is a possibility of a false alarm only on any of the

$$N_{FA} = N_u' + m - K = q(K-1) + m - K$$

remaining cells.

It can be seen that N_{FA} is the maximum number of false alarms that may occur. Letting n equal the actual number of false alarms that occur, each with a probability P_{FA} of occurrence, then conditioned on N_{FA} , n has the binomial probability density function

$$P\{n|N_{FA}\} = \binom{N_{FA}}{n} P_{FA}^n (1-P_{FA})^{N_{FA}-n}$$

$$= \frac{N_{FA}!}{n! (N_{FA}-n)!} P_{FA}^n (1-P_{FA})^{N_{FA}-n} \quad \text{for } n=0, 1, 2 \dots N_{FA}$$

The expected value is calculated as follows

$$E[n|N_{FA}] = \sum_{n=0}^{N_{FA}} n \frac{N_{FA}!}{n! (N_{FA}-n)!} P_{FA}^n (1-P_{FA})^{N_{FA}-n}$$

$$= \sum_{n=1}^{N_{FA}} n \frac{N_{FA}!}{n! (N_{FA}-n)!} P_{FA}^n (1-P_{FA})^{N_{FA}-n}$$

$$= \sum_{n=1}^{N_{FA}} \frac{N_{FA}!}{(n-1)! (N_{FA}-n)!} P_{FA}^n (1-P_{FA})^{N_{FA}-n}$$

After factoring out N_{FA} and P_{FA} one obtains

$$E[n|N_{FA}] = N_{FA} P_{FA} \sum_{n=1}^{N_{FA}} \frac{(N_{FA}-1)!}{(n-1)! (N_{FA}-n)!} P_{FA}^{n-1} (1-P_{FA})^{N_{FA}-n}$$

To further simplify, let $y = n-1$. The result yields

$$E[n|N_{FA}] = N_{FA} P_{FA} \sum_{y=0}^{N_{FA}-1} \frac{(N_{FA}-1)!}{y! (N_{FA}-1-y)!} P_{FA}^y (1-P_{FA})^{N_{FA}-1-y}$$

The quantity being summed is the binomial probability of y false alarms in $N_{FA}-1$ trials. Since the sum over all possible values of y equals one, then

$$E \left[n | N_{FA} \right] = N_{FA} P_{FA} \quad [11]$$

Since for each of the n false alarms a penalty time of Kt_d seconds is assessed, then the penalty time due to false alarms is

$$T_p = nKt_d$$

The total acquisition time is the sum of $T_{acq} + T_p$

$$T_{acq} = T_{acq0} + T_p = \left[N_u' + m + nK \right] t_d \quad [12]$$

The mean acquisition time is obtained by averaging T_{acq}

$$\begin{aligned} \overline{T_{acq}} &= \left[\frac{(2-P_D)q + P_D}{2P_D} + \overline{N_{FA}} P_{FA} K \right] t_d \\ \overline{N_{FA}} &= \overline{N_u' + m - k} = \frac{(2-P_D)q + P_D}{2P_D} - \frac{1}{P_D} = \frac{(2-P_D)q + P_D - 2}{2P_D} \\ \overline{T_{acq}} &= \left[\frac{(2-P_D)q + P_D}{2P_D} + \left[\frac{(2-P_D)q + P_D - 2}{2P_D} \right] K P_{FA} \right] t_d \\ &= \left[\frac{2q - P_D q + P_D - 2K P_{FA} + P_D K P_{FA} + 2q K P_{FA} - P_D q K P_{FA}}{2P_D} \right] t_d \\ \overline{T_{acq}} &= \left[\frac{2 + (2 - P_D)(q - 1)(1 + K P_{FA})}{2P_D} \right] t_d \quad [13] \end{aligned}$$

Using Equation [11], along with the following

$$E \left[n^2 \mid N_{FA} \right] = \bar{n}^2$$

$$\sigma^2 n \mid N_{FA} = \overline{n^2} - \bar{n}^2$$

$$\overline{n^2} = \sigma^2 n \mid N_{FA} + \bar{n}^2 = N_{FA} P_{FA} (1 - P_{FA}) + (N_{FA} P_{FA})^2$$

yields

$$E \left[T_{acq}^2 \mid N_{FA} \right] = t_d^2 \left[N_{FA}^2 + 2KN_{FA} (N_{FA} P_{FA}) + K^2 \left[N_{FA} P_{FA} (1 - P_{FA}) + N_{FA}^2 P_{FA}^2 \right] \right]$$

$$E \left[T_{acq}^2 \mid N_{FA} \right] = \left[N_{FA}^2 (1 + KP_{FA})^2 + N_{FA} K^2 P_{FA} (1 - P_{FA}) \right] t_d^2 \quad [14]$$

Similarly using Equation [11] one has

$$E \left[T_{acq} \mid N_{FA} \right] = E \left[(N_{FA} + nK) \mid N_{FA} \right] t_d \quad [15]$$

$$= (N_{FA} + KN_{FA} P_{FA}) t_d$$

$$= N_{FA} (1 + KP_{FA}) t_d$$

By averaging Equations [14] and [15] over the distribution N_{FA} , one arrives at the

unconditional second and first moments of T_{acq} . Thus

$$E \left[T_{acq}^2 \right] = \left[\overline{N_{FA}^2} (1 + KP_{FA})^2 + \overline{N_{FA}} K^2 P_{FA} (1 - P_{FA}) \right] t_d^2$$

$$E \left[T_{acq} \right] = \overline{N_{FA}} (1 + KP_{FA}) t_d$$

Equation [13] represents the mean time to acquire a single dwell direct sequence spread spectrum system having a non zero false alarm probability.

To obtain the variance of T_{acq} , one has from the basic definition

$$\sigma^2_{acq} = \overline{T^2_{acq}} - (\overline{T_{acq}})^2$$

from before, one knows that $N_{FA} = q(K-1) + m - k = (q-1)K - q + m$
for $q \gg 1$

one obtains $N_{FA} = qK - q + m = q(K-1) + m = N_u' + m$

Using Equation [12] one can calculate the expected value of the acquisition time (conditioned on N_{FA}) squared.

$$\begin{aligned} E \left[T^2_{acq} | N_{FA} \right] &= E \left[(N_u' + m + nK)^2 t_d^2 | N_{FA} \right] \\ &= E \left[(N_{FA} + nK)^2 | N_{FA} \right] t_d^2 \\ &= E \left[(N_{FA}^2 + 2N_{FA}nK + n^2K^2) | N_{FA} \right] t_d^2 \\ &= t_d^2 \left[E \left[N_{FA}^2 | N_{FA} \right] + E \left[(2N_{FA}nK) | N_{FA} \right] + E \left[(n^2K^2) | N_{FA} \right] \right] \end{aligned}$$

which yields

$$E \left[T^2_{acq} | N_{FA} \right] = T_d^2 \left[N_{FA}^2 + 2K E \left[nN_{FA} | N_{FA} \right] + K^2 E \left[n^2 | N_{FA} \right] \right]$$

and finally the variance of T_{acq} is

$$\begin{aligned}\sigma^2_{acq} &= \overline{T^2_{acq}} - (\overline{T_{acq}})^2 \\ &= t_d^2 \overline{N_{FA}^2} (1 + KP_{FA})^2 + \overline{N_{FA}} K^2 P_{FA} (1 - P_{FA}) t_d^2 - (\overline{N_{FA}})^2 (1 + KP_{FA})^2 t_d^2 \\ &= \left[\sigma^2_{N_{FA}} (1 + KP_{FA})^2 + \overline{N_{FA}} K^2 P_{FA} (1 - P_{FA}) \right] t_d^2\end{aligned}\quad [16]$$

It can be seen that $\sigma^2_{acq0} = \sigma^2_{N_{FA}} t_d^2$ and $\overline{T_{acq0}} = \overline{N_{FA}} t_d$ by the approxima

that $N_{FA} = N_u' + m$ for $q \gg 1$.

Thus after substituting the above into Equation [16] and rearranging, one obtains

$$\begin{aligned}\sigma^2_{acq} &= \left[\frac{\sigma^2_{acq0}}{t_d^2} (1 + KP_{FA})^2 + \frac{\overline{T_{acq0}}}{t_d} K^2 P_{FA} (1 - P_{FA}) \right] t_d^2 \\ \sigma^2_{acq} &= t_d^2 \left[\frac{q^2 t_d^2}{t_d^2} \left[\frac{1}{12} + \frac{1}{P_D^2} - \frac{1}{P_D} \right] (1 + KP_{FA})^2 + \frac{t_d}{t_d} \left[\frac{(2 - P_D)q + P_D}{2P_D} \right] K^2 P_{FA} (1 - P_{FA}) \right] \\ &= t_d^2 (1 + KP_{FA})^2 q^2 \left[\frac{1}{12} + \frac{1}{P_D^2} - \frac{1}{P_D} \right] + \\ &\quad t_d^2 \left[\frac{(2 - P_D)q + P_D}{2P_D} \right] K^2 P_{FA} (1 - P_{FA})\end{aligned}$$

If $K \ll q$ one obtains

$$\sigma^2_{acq} = t_d^2 (1 + KP_{FA})^2 q^2 \left[\frac{1}{12} + \frac{1}{P_D^2} - \frac{1}{P_D} \right] \quad [17]$$

Equation [17] represents the variance of a single dwell direct sequence spread

spectrum system having a non zero false alarm probability.

EVALUATION OF P_D AND P_{FA}

The general philosophy for determining the detection probability, P_D and the false alarm probability, P_{FA} , in terms of PN acquisition system parameters, is as follows. (Refer to Figure 7)

$$\begin{aligned} X(t) &= S(t) + n(t) \\ y(t) &= X^2(t) \end{aligned}$$

First the probability density function for X or equivalently R is determined. Then by transformation of random variables the probability density function for y is also determined (See Appendix I for derivation of the above)

As can be seen in figure 7, $y(t)$ is the input to the integrator. If $y(t)$ were sampled at intervals $T = 1/B$, then these samples are approximately independent and the integrator can be approximated by a summation. From this the probability density function of the output Z can be determined.

The probability of a false alarm is the probability that Z exceeds the threshold when the signal is absent.

$$P_{FA} = Q\left(\frac{\eta^* - N_B}{\sqrt{N_B}}\right) \quad [18]$$

Where $Q(X)$ = the gaussian probability integral

$$N_B = Bt_d$$

$$\eta^* = \text{the normalized threshold of the comparator} = \eta N_B / 2\sigma^2$$

The probability of detection is

$$P_D = Q\left[\frac{Q^{-1}(P_{FA}) - \sqrt{Bt_d} (A^2/N_0B)}{\sqrt{1 + 2\left(\frac{A^2}{N_0B}\right)}}\right] \quad [19]$$

Equations [18] and [19] show the interrelation of P_D , P_{FA} , S/N, bandwidth and dwell time.

The reader is requested to refer to Reference 15 for additional insight to Equations [18] and [19].

COMPUTER SIMULATION

The system that was simulated was a single dwell serial PN acquisition system. Figure 7 is a block diagram of such a system.

The purpose of the simulation was to investigate, show and verify how the level of noise affects the mean time to acquire, the number of false alarms and the number of missed detections for a single dwell serial PN acquisition system.

GENERAL COMPUTER SIMULATION REQUIREMENTS

1. Generate received code
2. Generate local code
3. Generate gaussian noise
4. Correlate the received code plus noise with the local code
5. Integrate the correlator output for a period of time
6. Compare integrator output with a threshold
7. Shift the local code on command.

The above requirements form a baseline for the program.

SPECIFIC COMPUTER SIMULATION REQUIREMENTS

CODE LENGTH

For the purpose of restricting the actual computer time while still obtaining worthwhile results, I chose to use a seven bit feedback generator as the code generator.

The seven bit feedback generator is set up as in figure 11. The generator has bit number one and seven combined in an exclusive or configuration and then fed back into bit one, when the generator shifts to the right. This configuration yields a linear maximal sequence of

$$2^7 - 1 = 127 \text{ bits in length}$$

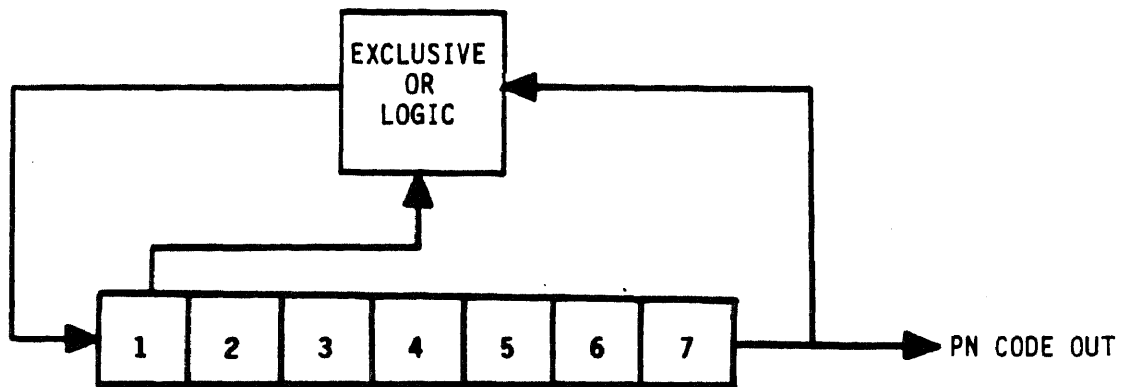

FIGURE 11 7 BIT FEEDBACK GENERATOR CONFIGURATION

GAUSSIAN NOISE

The noise used in the simulation is gaussian noise. The level of the noise is changed for each set of runs. The gaussian noise is generated by the following program lines⁵

```
R1 = RND (1)
R2 = RND (1)
X1 = SQR (-2* LOG (R1))
X1 = X1* COS (2*3.14159*R2)
NO = X1* VAR
```

To change the noise power the variable VAR is changed.

CORRELATION

The process of correlation consists of multiplying the received signal plus the gaussian noise by the local code generator.

Figure 12 shows the correlation process.

The computer program correlates the signals and integrates the correlator output over a period of five chips. During each chip five different values of noise are added to the received code and correlated with the local code.

5. "Understanding Computer Science - Volume II", R. S. Walker; Texas Instruments, Inc., Dallas, 1985.

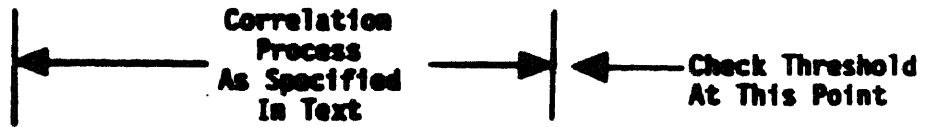
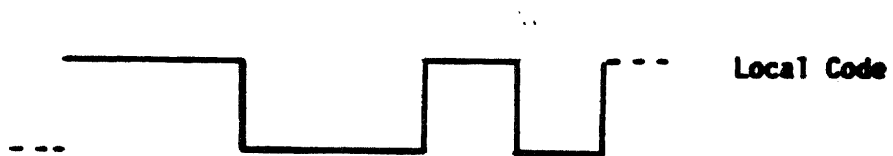
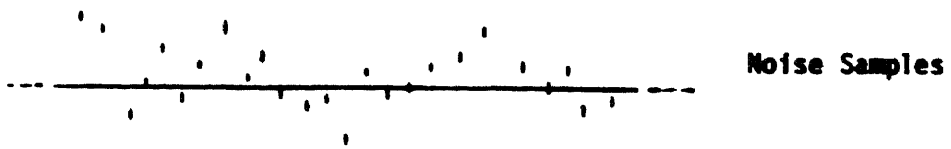

FIGURE 12 CORRELATION PROCESS

THRESHOLD

The value of threshold used in the program was

$$9 < \text{threshold} < 11$$

Since known values for correlation over the partial code length weren't readily available, the threshold was determined by observing partial correlation values and from the following.

If the local and received codes are in phase, and the value of noise added to the received code was zero, the threshold value would be

$$5[(1*1) + (1*1) + (1*1) + (1*1) + (1*1)] = 25$$

Where 5 is the dwell time in chips

The program divides the threshold by a factor of 2.5 thus setting a value of 10 for a sync threshold level for no noise present. After observation over many runs the threshold was set as stated above.

FALSE ALARMS

A false alarm means the simulated system thought the codes were in phase. A false alarm is recorded when the following events occur.

- A. The integrator output exceeds the threshold and proceeds to confirm synchronization.

During confirmation the local code phase is kept as is and the next five chips are processed.

- B. The integrator output is then compared with the threshold and found to be less than the threshold. Appendix II, Section 1 shows a computer printout of this process.

MISSED DETECTIONS

A missed detection means that during a complete search through the entire uncertainty region, the threshold was not exceeded three consecutive times. A missed detection is recorded by the program after the local code generator shifts 128 times. The program is capable of recording up to five missed detections before obtaining synchronization. Appendix II, Section 2 shows a computer printout of this process.

FLOW DIAGRAM

A simplified diagram for the simulated Single Dwell Serial Acquisition System is shown in figure 13.

SYNCHRONIZATION

Synchronization means that the received code and local code generator are in phase with each other.

The decision that the simulated system has obtained synchronization is made after confirming that the threshold has been exceeded three consecutive times.

Appendix II, Section 3 shows a computer printout of this process.

RESULTS OF SIMULATION

The simulation was performed for a number of different S/N ratios, and averaged over 32 runs for each S/N ratio. Table 3 shows a summary of the mean acquisition time, the mean number of false alarms, and the mean number of missed detections for each S/N ratio. Appendix II, Section 4 shows the computer printouts for each S/N ratio. The mean time to acquire versus the S/N ratio for the simulated single dwell serial acquisition system is shown in figure 14.

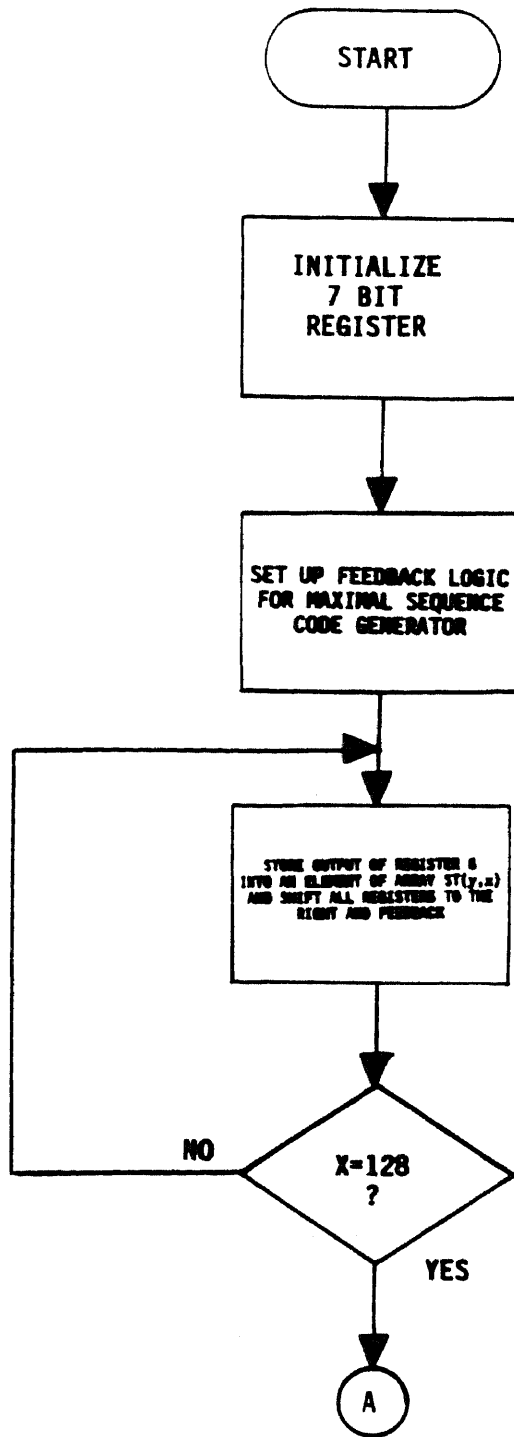

FIGURE 13 FLOW DIAGRAM FOR SINGLE DWELL SERIAL ACQUISITION SYSTEM SIMULATOR

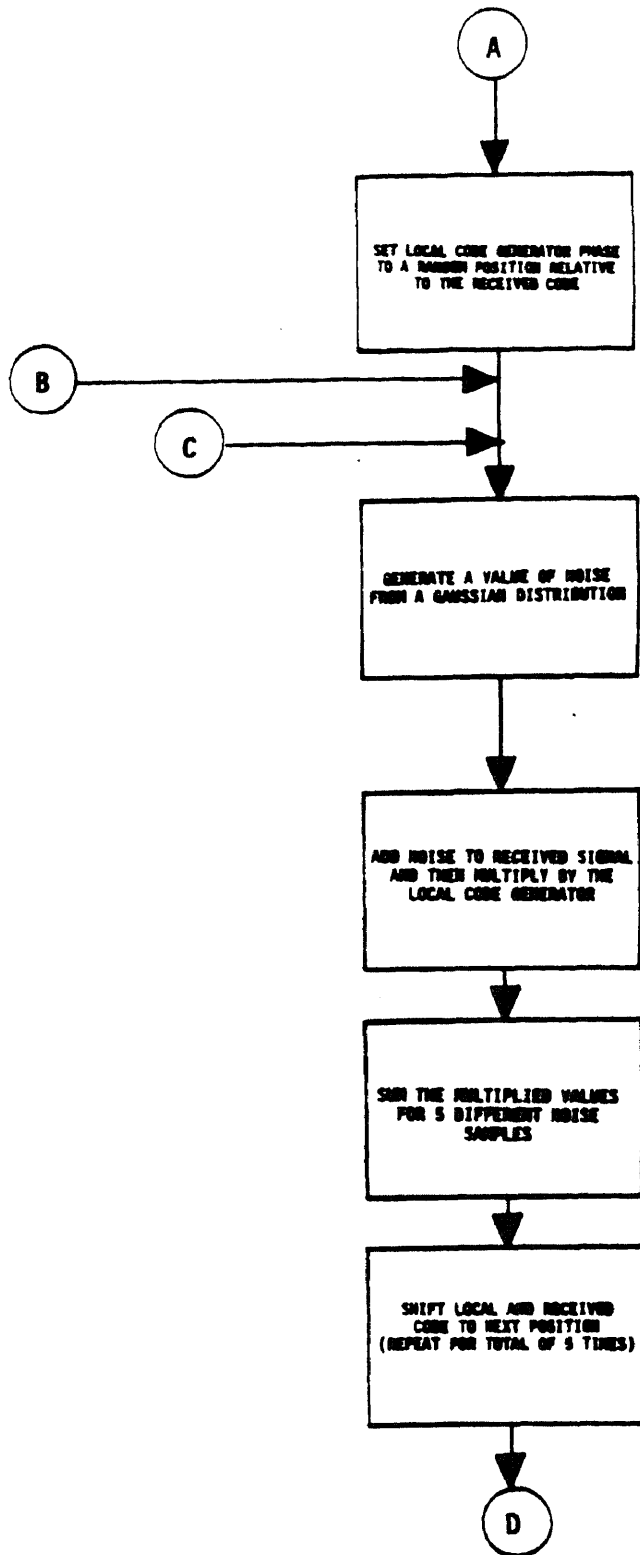

FIGURE 13 CONTINUED

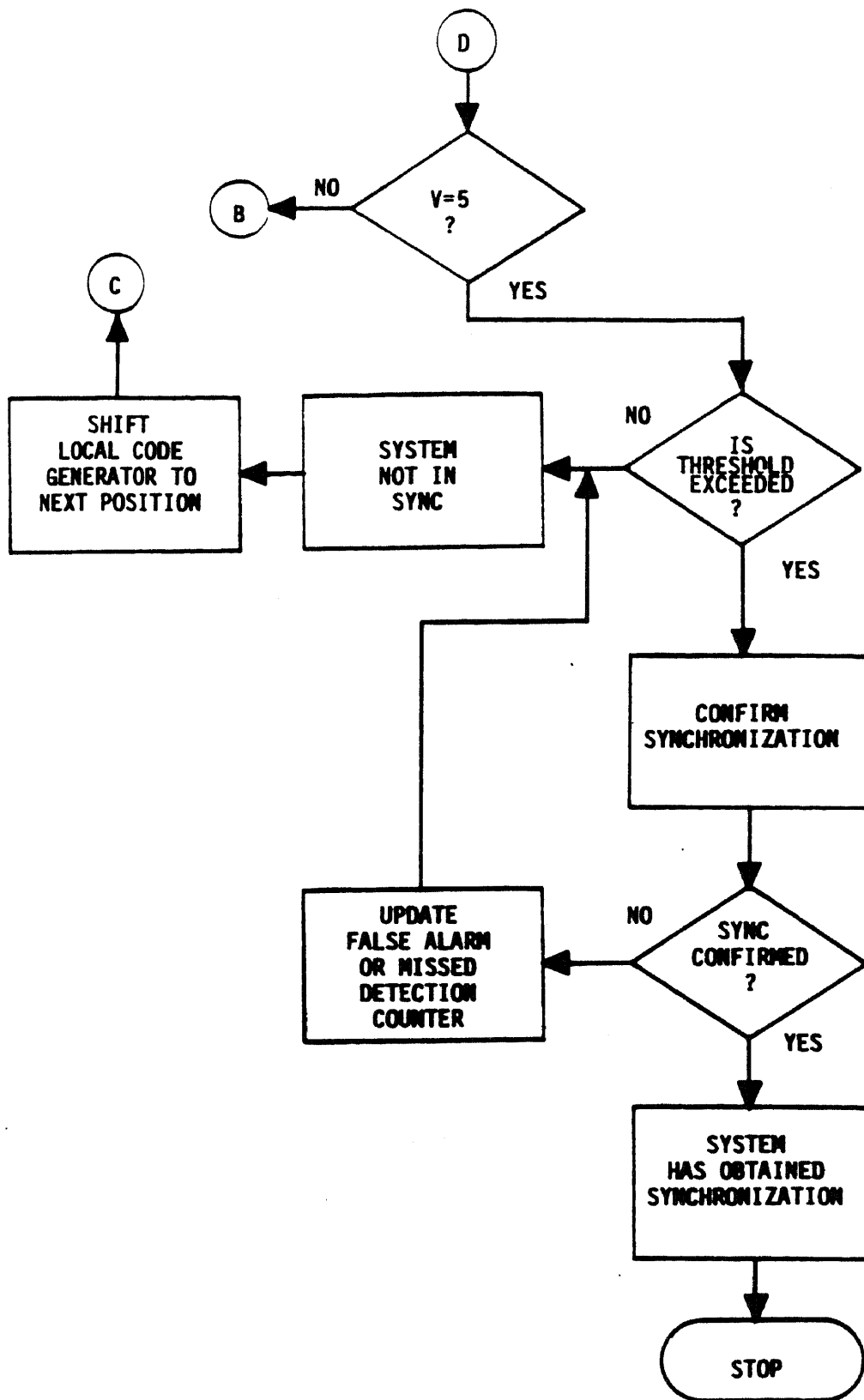

FIGURE 13 CONTINUED

| σ^2 | S/N | T_{acq} | False Alarms | Missed Detections |
|------------|----------|-----------|--------------|-------------------|
| .05 | -14dB | 77.35 | 6.7 | .1875 |
| .10 | -17dB | 80.4375 | 5.4375 | .15625 |
| .15 | -18.75dB | 84.7 | 4.25 | .09375 |
| .20 | -20dB | 87.3125 | 5.6875 | .15625 |
| .25 | -21dB | 100.375 | 10.625 | .3125 |
| .30 | -21.75dB | 117.25 | 9.75 | .40625 |

$$\frac{S}{N} = \frac{A^2}{N_0 B} = \frac{A^2}{2\sigma^2}$$

$$N_{in}(\text{Process Gain}) = N_{out} = 2\sigma^2$$

$$\sigma^2 = \frac{N_{in}(\text{Process Gain})}{2} \quad \text{Assume Process Gain} = 1000 = 30\text{dB}$$

$$S/N = -10\log(\sigma^2 (500)) \quad \text{Where } \sigma^2 = \text{variance of noise in simulator}$$

S/N in Table are relative to a process gain of 30dB.

The numbers listed in the Table above are the mean numbers per run.

Table 3 Summary of Simulation Data

COMPUTER PROGRAM

The computer program used to simulate a Single Dwell Serial PN Acquisition System was written in Basic. The program is shown in Appendix II, Section 5.

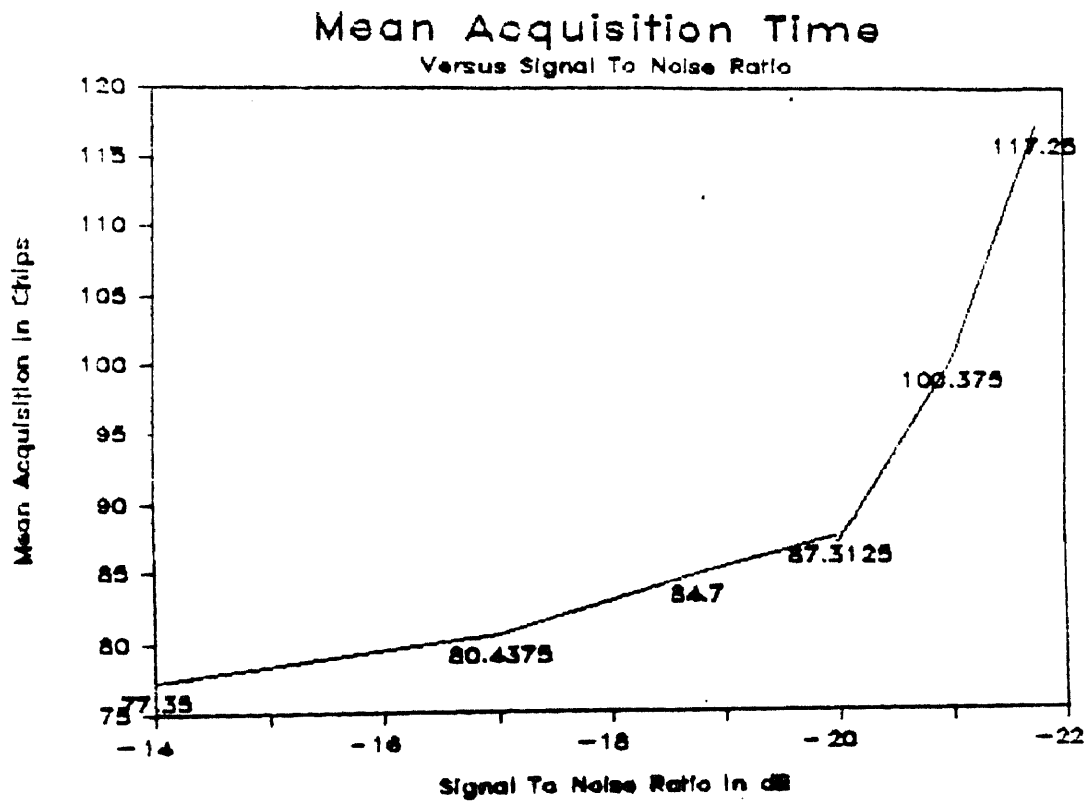

Figure 14 Curve of the Mean Acquisition Time for a Single Dwell Serial Acquisition System

CONCLUSIONS AND RECOMMENDATIONS

After examining the data in Table 3; the following conclusions and recommendations were determined.

As can be seen in the Table, as the S/N is decreased, (greater noise power) the mean acquisition time, \overline{T}_{acq} , increases. This is evident in particular by observing the \overline{T}_{acq} and the mean number of missed detections in Table 3, for S/N of -20dB, -21dB, and -21.75dB. It is seen that the mean number of missed detections are the main contributors to the increase in the mean acquisition time. The contribution to an increase in the mean acquisition time due to a false alarm is much less than that due to a missed detection (i.e., 3 chips per false alarm and 128 per missed detection).

It is also noticed that for the S/N of -17dB and -20dB the mean number of missed detections are equal, yet the mean acquisition times differ. This is probably caused by the random initial code phase between the received and local code.

For future recommendations I would keep the initial code phase between the received and local code generators constant and then study the affects of S/N on the change in mean acquisition time, from the expected (the expected can be determined from the known initial starting position) acquisition time. This would give a better understanding of how the false alarms and missed detections affect the mean acquisition time.

Blank Page

APPENDIX I

CALCULATION OF THE PROBABILITY DENSITY FUNCTION OF Y

For the following analysis refer to Figure 7.

$$\begin{aligned} X(t) &= S(t) + n(t) = \sqrt{2} A \cos(\omega_0 t + \psi) \\ &\quad + \sqrt{2} n_c(t) \cos(\omega_0 t + \psi) \\ &\quad - \sqrt{2} n_s(t) \sin(\omega_0 t + \psi) \\ &= \sqrt{2} R(t) \cos(\omega_0 t + \psi + \theta(t)) \end{aligned}$$

where

$$R(t) = \sqrt{(A + n_c(t))^2 + n_s^2(t)}$$
$$\theta(t) = \tan^{-1} \left(\frac{n_s(t)}{A + n_c(t)} \right)$$

A = rms signal amplitude

ω_0 = the radian carrier frequency

$n_c(t)$, $n_s(t)$ are band limited, independent, low pass, zero mean

Gaussian noise processes with a variance, $\sigma^2 = N_0 B/2$;

where N_0 is the single sided noise spectral density and B is the noise bandwidth of the predetection band-pass filter.

The output of the square law envelope detector is

$$y(t) = X^2(t) = R^2(t) = (A + n_c(t))^2 + n_s^2(t)$$

Let

$$W = A + n_c(t) \rightarrow \begin{cases} \sigma^2 = \text{variance} = N_0 B/2 \\ \mu = \text{mean} = A \end{cases}$$

$$n_s(t) \rightarrow \begin{cases} \sigma^2 = \text{variance} = N_0 B/2 \\ \mu = \text{mean} = 0 \end{cases}$$

$$f_2(W, n_s) = f(W)f(n_s)$$

$$= \frac{1}{2\pi\left(\frac{N_0B}{2}\right)} e^{-\frac{1}{2\left(\frac{N_0B}{2}\right)}\left[(W-A)^2 + n_s^2\right]}$$

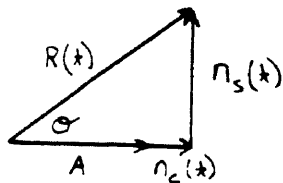

$$W = A + n_c(t)$$

$$\text{Let } W = R(t) \cos \theta$$

$$n_s = R(t) \sin \theta$$

transforming variables yields

$$g_2(R, \theta) = f_2(W, n_s) \frac{\partial(W, n_s)}{\partial(R, \theta)} = f_2(W, n_s) \begin{vmatrix} \frac{\partial W}{\partial R} & \frac{\partial W}{\partial \theta} \\ \frac{\partial n_s}{\partial R} & \frac{\partial n_s}{\partial \theta} \end{vmatrix}$$

$$\begin{vmatrix} \frac{\partial W}{\partial R} & \frac{\partial W}{\partial \theta} \\ \frac{\partial n_s}{\partial R} & \frac{\partial n_s}{\partial \theta} \end{vmatrix} = \begin{vmatrix} \cos \theta & -R \sin \theta \\ \sin \theta & R \cos \theta \end{vmatrix} = R \cos^2 \theta - (-R \sin^2 \theta) = R$$

$$g_2(R, \theta) = R \frac{1}{2\pi \left(\frac{N_0 B}{2}\right)} e^{-\frac{1}{2\left(\frac{N_0 B}{2}\right)} \left[(R \cos \theta - A)^2 + (R \sin \theta)^2 \right]}$$

$$= \frac{R}{2\pi \left(\frac{N_0 B}{2}\right)} e^{-\frac{1}{2\left(\frac{N_0 B}{2}\right)} \left[R^2 + A^2 - 2RA \cos \theta \right]} \quad \text{for } \begin{cases} R \geq 0 \\ |\theta| < \pi \end{cases}$$

R and θ are not statistically independent because of the term $2RA \cos \theta$ in the above equation. Therefore to obtain $P(R)$ we integrate over θ .

$$P(R) = \int_{-\pi}^{\pi} g_2(R, \theta) d\theta = \frac{R}{2\pi \left(\frac{N_0 B}{2}\right)} e^{-\frac{1}{2\left(\frac{N_0 B}{2}\right)} \left[R^2 + A^2 \right]} \int_{-\pi}^{\pi} e^{-\frac{1}{2\left(\frac{N_0 B}{2}\right)} (-2RA \cos \theta)} d\theta$$

$$P(R) = \frac{R}{2\pi \left(\frac{N_0 B}{2}\right)} e^{-\left[\frac{1}{N_0 B} \left[R^2 + A^2 \right] \right]} \int_{-\pi}^{\pi} e^{\frac{2RA}{N_0 B} \cos \theta} d\theta$$

$$\int_{-\pi}^{\pi} e^{-\frac{2AR}{N_0 B} \cos \theta} d\theta = \int_0^{2\pi} e^{V \cos \theta} d\theta = 2\pi I_0(V)$$

Where $I_0(V)$ is the modified Bessel function of the first kind and zero order.

$$\gamma = \text{Predetection signal-to-noise ratio} = \frac{A^2}{N_0 B} = \frac{A^2}{2\sigma^2}$$

$$A = \sqrt{\gamma N_0 B}$$

By transformation of random variables

$$P(Y) = P(R) \left| \frac{\partial R}{\partial Y} \right|$$

$$Y(t) = R^2(t) \quad \frac{\partial Y}{\partial R} = 2R$$

$$R(t) = \sqrt{Y(t)}$$

$$P(Y) = \frac{R}{2\pi \left(\frac{N_0 B}{2}\right)} e^{-\frac{1}{2\left(\frac{N_0 B}{2}\right)} [R^2 + A^2]} \cdot 2\pi I_0\left(\frac{2AR}{N_0 B}\right) \frac{1}{2R}$$

$$= \frac{e^{-\left[\frac{R^2}{N_0 B} + \frac{A^2}{N_0 B}\right]}}{N_0 B} I_0\left(\frac{2AR}{N_0 B}\right)$$

$$= \frac{e^{-\left[\frac{Y}{2\sigma^2} + \delta\right]}}{2\sigma^2} I_0\left(\frac{2\sqrt{\delta N_0 B}\sqrt{Y}}{\sqrt{N_0 B}\sqrt{N_0 B}}\right)$$

$$P(Y) = \frac{1}{2\sigma^2} e^{-\left[\frac{Y}{2\sigma^2} + \delta\right]} I_0\left(2\sqrt{\frac{\delta Y}{2\sigma^2}}\right)$$

APPENDIX II

SECTION 1
FALSE ALARM PRINTOUT

#648 #636 SUM = -6.04300043
#636 #644
#644 NUMBER OF FALSE ALARMS = 4
#644 #648
#648 #648 75
#648 #636 SUM = 2.20190902
#636 #644
#644 NUMBER OF FALSE ALARMS = 4
#644 #648
#648 #648 76
#648 #636 SUM = 2.08630668
#636 #644
#644 NUMBER OF FALSE ALARMS = 4
#644 #648
#648 #648 77
#648 #636 SUM = -1.97423452
#636 #644
#644 NUMBER OF FALSE ALARMS = 4
#644 #648
#648 #648 78
#648 #636 SUM = -1.71352786
#636 #644
#644 NUMBER OF FALSE ALARMS = 4
#644 #648
#648 #648 79
#648 #636 SUM = 9.95925479
#636 #647 ---- CONFIRMING SYNCHRONIZATION ----
#647 #648
#648 #648 80
#648 #636 SUM = -6.03810784
#636 #647 ---- CONFIRMING SYNCHRONIZATION ----
#647 #648
#648 #648 81
#648 #636 SUM = 5.7818521
#636 #644
#644 NUMBER OF FALSE ALARMS = 5
#644 #648
#648 #648 82
#648 #636 SUM = 2.23969242
#636 #644
#644 NUMBER OF FALSE ALARMS = 5
#644 #648
#648 #648 83
#648 #636 SUM = 1.91437272
#636 #644
#644 NUMBER OF FALSE ALARMS = 5
#644 #648
#648 #648 84
#648 #636 SUM = -1.73699189
#636 #644
#644 NUMBER OF FALSE ALARMS = 5
#644 #648
#648 #648 85
#648 #636 SUM = -.0645484611
#636 #644
#644 NUMBER OF FALSE ALARMS = 5
#644 #648
#648 #648 86
#648 #636 SUM = 1.63963919
#636 #644
#644 NUMBER OF FALSE ALARMS = 5
#644 #648
#648 #648 87
#648 #636 SUM = 2.03270724
#636 #644
#644 NUMBER OF FALSE ALARMS = 5

SECTION 2
MISSED DETECTION PRINTOUT

0077 0070
#648 #648 122
#648 #636 SUM = 2.10805396
#636 #644
#644 NUMBER OF FALSE ALARMS = 2
#644 #648
#648 #648 123
#648 #636 SUM = 1.73848092
#636 #644
#644 NUMBER OF FALSE ALARMS = 2
#644 #648
#648 #648 124
#648 #636 SUM = -2.30440017
#636 #644
#644 NUMBER OF FALSE ALARMS = 2
#644 #648
#648 #648 125
#648 #636 SUM = 5.87142063
#636 #644
#644 NUMBER OF FALSE ALARMS = 2
#644 #648
#648 #648 126
#648 #636 SUM = -2.294652
#636 #644
#644 NUMBER OF FALSE ALARMS = 2
#644 #648
#648 #648 127
#648 #636 SUM = -6.16611263
#636 #644
#644 NUMBER OF FALSE ALARMS = 2
#644 #648
#648 #648 128
#648 #636 SUM = 9.96371233
#636 #647 ---- CONFIRMING SYNCHRONIZATION ----
#647 #648
#648 #648 129
#648 #636 SUM = 10.250311
#636 #647 ---- CONFIRMING SYNCHRONIZATION ----
#647 #648
#648 #648 130
#648 #636 SUM = 10.4574008
#636 #1013 NUMBER OF MISSED DETECTIONS = 1
#1013 #1013 #1014 #1045
#1045 NUMBER OF RUNS =5
#1045
#1047 #636 SUM = 2.38320634
#636 #644
#644 NUMBER OF FALSE ALARMS = 0
#644 #648
#648 #648 1
#648 #636 SUM = -2.18175753
#636 #644
#644 NUMBER OF FALSE ALARMS = 0
#644 #648
#648 #648 2
#648 #636 SUM = -5.92451687
#636 #644
#644 NUMBER OF FALSE ALARMS = 0
#644 #648
#648 #648 3
#648 #636 SUM = 2.0078642
#636 #644
#644 NUMBER OF FALSE ALARMS = 0
#644 #648
#648 #648 4
#648 #636 SUM = 0.00000000

SECTION 3
SYNCHRONIZATION PRINTOUT

#644 #648
#648 #648 97
#648 #636 SUM = -3.86966571
#636 #644
#644 NUMBER OF FALSE ALARMS = 1
#644 #648
#648 #648 98
#648 #636 SUM = -5.83232082
#636 #644
#644 NUMBER OF FALSE ALARMS = 1
#644 #648
#648 #648 99
#648 #636 SUM = 2.19369754
#636 #644
#644 NUMBER OF FALSE ALARMS = 1
#644 #648
#648 #648 100
#648 #636 SUM = 1.96427331
#636 #644
#644 NUMBER OF FALSE ALARMS = 1
#644 #648
#648 #648 101
#648 #636 SUM = 5.78420285
#636 #644
#644 NUMBER OF FALSE ALARMS = 1
#644 #648
#648 #648 102
#648 #636 SUM = -1.60429801
#636 #644
#644 NUMBER OF FALSE ALARMS = 1
#644 #648
#648 #648 103
#648 #636 SUM = -1.9426496
#636 #644
#644 NUMBER OF FALSE ALARMS = 1
#644 #648
#648 #648 104
#648 #636 SUM = 1.83829439
#636 #644
#644 NUMBER OF FALSE ALARMS = 1
#644 #648
#648 #648 105
#648 #636 SUM = 10.0370826
#636 #647 ---- CONFIRMING SYNCHRONIZATION ----
#647 #648
#648 #648 106
#648 #636 SUM = 10.271374
#636 #647 ---- CONFIRMING SYNCHRONIZATION ----
#647 #648
#648 #648 107
#648 #636 SUM = 9.73614647
#636 #1013 NUMBER OF MISSED DETECTIONS = 0
#1013 #1013 #1014 #1045
#1045 NUMBER OF RUNS =4
#1045
#1047 #636 SUM = 1.86940072
#636 #644
#644 NUMBER OF FALSE ALARMS = 0
#644 #648
#648 #648 1
#648 #636 SUM = -2.02467978
#636 #644
#644 NUMBER OF FALSE ALARMS = 0
#644 #648

SECTION 4

COMPUTER PRINTOUT FOR ALL S/N

#2001

#2001 ***THE MEAN ACQUISITION TIME FOR 32 RUNS IS 77.34375***

#2008

#2008 THE MEAN NUMBER OF FALSE ALARMS OVER

#2010 THE SAME NUMBER OF RUNS EQUALS 6.71875

#2020

#2020 THE MEAN NUMBER OF MISSED DETECTIONS

#2022 OVER THE SAME NUMBER OF RUNS EQUALS .1875

#2001

#2001 ****THE MEAN ACQUISITION TIME FOR 32 RUNS IS 80.4375****

#2010

#2010 THE MEAN NUMBER OF FALSE ALARMS OVER THE SAME NUMBER OF RUNS EQUALS 5.4375

#2020

#2020 THE MEAN NUMBER OF MISSED DETECTIONS OVER THE SAME NUMBER OF RUNS EQUALS .

15625

#2001

#2001 ****THE MEAN ACQUISITION TIME FOR 32 RUNS IS 84.71875****

#2008

#2008 THE MEAN NUMBER OF FALSE ALARMS OVER

#2010 THE SAME NUMBER OF RUNS EQUALS 4.25

#2020

#2020 THE MEAN NUMBER OF MISSED DETECTIONS

#2022 OVER THE SAME NUMBER OF RUNS EQUALS .09375

#2030 #2001

#2001 ****THE MEAN ACQUISITION TIME FOR 32 RUNS IS 87.3125****

#2008

#2008 THE MEAN NUMBER OF FALSE ALARMS OVER

#2010 THE SAME NUMBER OF RUNS EQUALS 5.6875

#2020

#2020 THE MEAN NUMBER OF MISSED DETECTIONS

#2022 OVER THE SAME NUMBER OF RUNS EQUALS .15625

#2030 #2001

#2001 ****THE MEAN ACQUISITION TIME FOR 32 RUNS IS 100.375****

#2008

#2008 THE MEAN NUMBER OF FALSE ALARMS OVER

#2010 THE SAME NUMBER OF RUNS EQUALS 10.625

#2020

#2020 THE MEAN NUMBER OF MISSED DETECTIONS

#2022 OVER THE SAME NUMBER OF RUNS EQUALS .3125

#2030 #2001

#2001 ****THE MEAN ACQUISITION TIME FOR 32 RUNS IS 117.25****

#2008

#2008 THE MEAN NUMBER OF FALSE ALARMS OVER

#2010 THE SAME NUMBER OF RUNS EQUALS 9.75

#2020

#2020 THE MEAN NUMBER OF MISSED DETECTIONS

#2022 OVER THE SAME NUMBER OF RUNS EQUALS .40625

SECTION 5
PROGRAM LISTING

#2030

JLIST

```
5 DIM ST(5,140)
10 A = 1:B = 1:C = 1:D = 1:E = 1:F = 1:G = 1
20 OUT = G
100 IF A + OUT < > 1 THEN 150
110 IN = 1
120 GOTO 190
150 IN = 0
190 IF OUT = 1 THEN 200
192 POUT = - 1
195 GOTO 209
200 POUT = OUT
209 X = X + 1:ST(Y,X) = POUT
210 G = F
220 OUT = F
230 F = E
231 E = D
232 D = C
233 C = B
234 B = A
235 A = IN
270 W = W + 1: IF W = 127 THEN 300
275 GOTO 100
300 Y = Y + 1:X = 0
310 W = 0:SH = 0
315 IF Y < 3 THEN GOTO 10
440 FOR O = 1 TO INT (127 * RND (1))
450 PRINT O
500 TEMP = ST(1,1)
520 FOR X = 1 TO 126
530 ST(1,X) = ST(1,X + 1)
540 NEXT X
550 ST(1,127) = TEMP
551 IF FLAG = 1 THEN 600
552 NEXT O
555 IF FLAG = 1 THEN 600
600 FOR V = 1 TO 5
605 CT = CT + 1
606 IF CT = 128 THEN CT = 0: GOTO 608
608 FOR VJ = 1 TO 5
609 R1 = RND (1)
610 R2 = RND (1)
611 X1 = SQR ( - 2 * LOG (R1))
612 X1 = X1 * COS (2 * 3.1459 * R2)
613 W0 = X1 * .25
617 THR = (ST(0,CT) + W0) * ST(1,CT)
620 S2UM = S2UM + THR
628 NEXT VJ
629 SUM = SUM + S2UM:S2UM = 0
630 NEXT V
635 SUM = SUM / 2.5
636 PRINT "SUM = ";SUM
640 IF (SUM > 9) AND (SUM < 11) THEN 1000
641 IF (GD = 1) AND (FF = 1) THEN FA = FA + 1:MFA = MFA + FA: GOTO 647
643 PRINT "SYSTEM NOT IN SYNC SUM = ";SUM
644 PRINT : PRINT "NUMBER OF FALSE ALARMS = ";FA
645 FF = 0
646 IF CK < > 1 THEN GOTO 648
647 PRINT "---- CONFIRMING SYNCHRONIZATION ----"
```

```

652 IF ACQ > 258 THEN MD = 2: GOTO 654
653 IF ACQ > 129 THEN MD = 1: GOTO 654
654 FLAG = 1
655 SUM = 0
656 IF CK = 1 THEN GOTO 661
657 GD = 0
660 GOTO 500
661 CK = 0
662 GOTO 600
1000 GD = GD + 1
1001 FF = 1
1002 IF GD > 2 THEN 1008
1004 CK = 1
1006 GOTO 646
1008 PRINT "SYSTEM HAS OBTAINED SYNCHRONIZATION"
1011 FA = 0
1013 PRINT "NUMBER OF MISSED DETECTIONS = ";MD:MMD = MMD + MD:MD = 0
1016 GD = 0
1020 FLAG = 0
1030 A2CQ = A2CQ + ACQ
1040 AV = AV + 1
1045 PRINT : PRINT "NUMBER OF RUNS =";AV: PRINT
1050 ACQ = 0
1055 IF AV = 32 THEN 64
1060 PRINT : PRINT A2CQ / AV: PRINT
1070 FOR T = 1 TO 127
1080 ST(1,T) = ST(0,T)
1090 NEXT T
1100 GOTO 440
2000 PR# 1
2001 PRINT : PRINT "+++THE MEAN ACQUISITION TIME FOR ";AV;" RUNS IS ";
A2CQ / AV;"+++"
2008 PRINT : PRINT " THE MEAN NUMBER OF FALSE ALARMS OVER"
2010 PRINT " THE SAME NUMBER OF RUNS EQUALS ";MFA / AV
2020 PRINT : PRINT " THE MEAN NUMBER OF MISSED DETECTIONS"
2022 PRINT " OVER THE SAME NUMBER OF RUNS EQUALS ";MMD / AV
2030 PR# 0

```

JPR#0

LIST OF REFERENCES

1. S. Davidovici, L. B. Milstein, and D. L. Schilling, "A New Rapid Acquisition Technique for Direct Sequence Spread Spectrum Communications", IEEE Trans. Commun., vol. com-32, pp. 1161-1168, Nov., 1984.
2. R. A. Iltis and L. B. Milstein, "Performance Analysis of Narrow-Band Interference Rejection Techniques in DS Spread Spectrum Systems", IEEE Trans. Commun., vol. com-32, pp. 1169-1177, Nov., 1984.
3. M. Moeneclaey, "Two Maximum-Likelihood Symbol Synchronizers with Superior Tracking Performance", IEEE Trans. Commun., vol. com-32, pp. 1978-1985, Nov., 1984.
4. G. J. Saulnier, P. Das, and L. B. Milstein, "Suppression of Narrow-Band Interference in a PN Spread Spectrum Receiver using a CTD-Based Adaptive Filter", IEEE Trans. Commun., vol. com-32, pp. 1227-1232, Nov., 1984.
5. G. Cherubini and S. Pupolin, "Performance Analysis of an All-Digital Acquisition Circuit", IEEE Trans. Commun., vol. com-33, pp. 862-868, Aug., 1985.
6. A. Polydorus and C. L. Weber, "A Unified Approach to Serial Search Spread Spectrum Code Acquisition - Part I: General Theory", IEEE Trans. Commun., vol. com-32, pp. 542-549, May, 1984.
7. A. Polydorus and C. L. Weber, "A Unified Approach to Serial Search Spread Spectrum Code Acquisition - Part II: A Matched Filter-Receiver", IEEE Trans. Commun., vol. com-32, pp. 550-560, May, 1984.
8. D. V. Sarwate, M. B. Pursley, and T. U. Basar, "Partial Correlation Effects in Direct Sequence Spread Spectrum Multiple-Access Communication Systems", IEEE Trans. Commun., vol. com-32, pp. 567-573, May, 1984.
9. A. Polydorus and M. K. Simon, "Generalized Serial Search Code Acquisition: The Equivalent Circular State Diagram Approach", IEEE Trans. Commun., vol. com-32, pp. 1260-1268, Dec., 1984.
10. S. S. Rappaport and D. M. Grieco, "Spread Spectrum Signal Acquisition: Methods and Technology", IEEE Communications Magazine, vol. 22, pp. 6-21, June, 1984.
11. L. B. Milstein, J. Gievargiz, and P. K. Das, "Rapid Acquisition for Direct Sequence Spread Spectrum Communications Using Parallel Saw Convolvers", IEEE Trans. Commun., vol. Com-33, pp. 593-600, July, 1985.

12. Ziemer, R. H. and Tranter, W. H.: Principles of Communications - Systems, Modulation, and Noise, Houghton Mifflin Company, Boston, 1976.
13. Papoulis, A.: Probability, Random Variables, and Stochastic Processes, McGraw-Hill Book Company, New York, 1984.
14. Hoel, P. G.: Introduction to Mathematical Statistics, Fifth Edition, John Wiley & Sons, New York, 1984.
15. Simon, M. K.; Omura, J. K.; Scholtz, R. A.; Levitt, B. K.: Spread Spectrum Communications, Computer Science Press, Inc., 1985. (I, III)
16. Walter, R. S.: Understanding Computer Science - Volume II, Texas Instruments, Inc., Dallas, 1985.
17. Dixon, R. C.: Spread Spectrum Systems - Second Edition, John Wiley & Sons, New York, 1984.