

Copyright Warning & Restrictions

The copyright law of the United States (Title 17, United States Code) governs the making of photocopies or other reproductions of copyrighted material.

Under certain conditions specified in the law, libraries and archives are authorized to furnish a photocopy or other reproduction. One of these specified conditions is that the photocopy or reproduction is not to be “used for any purpose other than private study, scholarship, or research.” If a user makes a request for, or later uses, a photocopy or reproduction for purposes in excess of “fair use” that user may be liable for copyright infringement,

This institution reserves the right to refuse to accept a copying order if, in its judgment, fulfillment of the order would involve violation of copyright law.

Please Note: The author retains the copyright while the New Jersey Institute of Technology reserves the right to distribute this thesis or dissertation

Printing note: If you do not wish to print this page, then select “Pages from: first page # to: last page #” on the print dialog screen

The Van Houten library has removed some of the personal information and all signatures from the approval page and biographical sketches of theses and dissertations in order to protect the identity of NJIT graduates and faculty.

INFORMATION TO USERS

This reproduction was made from a copy of a document sent to us for microfilming. While the most advanced technology has been used to photograph and reproduce this document, the quality of the reproduction is heavily dependent upon the quality of the material submitted.

The following explanation of techniques is provided to help clarify markings or notations which may appear on this reproduction.

1. The sign or "target" for pages apparently lacking from the document photographed is "Missing Page(s)". If it was possible to obtain the missing page(s) or section, they are spliced into the film along with adjacent pages. This may have necessitated cutting through an image and duplicating adjacent pages to assure complete continuity.
2. When an image on the film is obliterated with a round black mark, it is an indication of either blurred copy because of movement during exposure, duplicate copy, or copyrighted materials that should not have been filmed. For blurred pages, a good image of the page can be found in the adjacent frame. If copyrighted materials were deleted, a target note will appear listing the pages in the adjacent frame.
3. When a map, drawing or chart, etc., is part of the material being photographed, a definite method of "sectioning" the material has been followed. It is customary to begin filming at the upper left hand corner of a large sheet and to continue from left to right in equal sections with small overlaps. If necessary, sectioning is continued again—beginning below the first row and continuing on until complete.
4. For illustrations that cannot be satisfactorily reproduced by xerographic means, photographic prints can be purchased at additional cost and inserted into your xerographic copy. These prints are available upon request from the Dissertations Customer Services Department.
5. Some pages in any document may have indistinct print. In all cases the best available copy has been filmed.

**University
Microfilms
International**
300 N. Zeeb Road
Ann Arbor, MI 48106

8416157

Chu, Thomas Tai-Pai

**USE OF AN OPTICAL PROBE TO MEASURE BUBBLE CHARACTERISTICS IN
GAS FLUIDIZED BEDS**

New Jersey Institute of Technology

D.ENG.SC.

1984

**University
Microfilms
International** 300 N. Zeeb Road, Ann Arbor, MI 48106

PLEASE NOTE:

In all cases this material has been filmed in the best possible way from the available copy. Problems encountered with this document have been identified here with a check mark .

1. Glossy photographs or pages
2. Colored illustrations, paper or print
3. Photographs with dark background
4. Illustrations are poor copy _____
5. Pages with black marks, not original copy _____
6. Print shows through as there is text on both sides of page _____
7. Indistinct, broken or small print on several pages
8. Print exceeds margin requirements _____
9. Tightly bound copy with print lost in spine _____
10. Computer printout pages with indistinct print
11. Page(s) _____ lacking when material received, and not available from school or author.
12. Page(s) _____ seem to be missing in numbering only as text follows.
13. Two pages numbered _____. Text follows.
14. Curling and wrinkled pages _____
15. Other _____

University
Microfilms
International

USE OF AN OPTICAL PROBE TO MEASURE
BUBBLE CHARACTERISTICS IN GAS FLUIDIZED BEDS

BY
THOMAS T. CHU

A DISSERTATION
SUBMITTED TO THE FACULTY OF THE GRADUATE SCHOOL
OF THE NEW JERSEY INSTITUTE OF TECHNOLOGY
IN PARTIAL FULFILLMENT OF THE REQUIREMENTS
FOR THE DEGREE OF
DOCTOR OF ENGINEERING SCIENCE
1984

VITA

Name: Thomas Tai-Pai Chu

Degree and date to be conferred: D. Eng. Sc., 1984

Secondary education: Taiwan Provincial Hsing-Chu
High School, 1969

Collegiate education:

B.S. CHE, Chung Yuang University, 1974

M.S. CHE, Tennessee Technological University, 1979

Sc.D. CHE, New Jersey Institute of Technology, 1984

Master Thesis: Determination of Surface Emittance of
Radiant Energy.

Paper presentation: With S. Dutta, "Measurement of
Bubble Characteristics By Optical
Probes", AIChE 73rd Annual Meeting,
1980.

Position held: Instructor of Department of Chemical
Engineering and Chemistry, New Jersey
Institute of Technology.

ABSTRACT

A novel optical probe has been developed and used for on-line monitoring of the bubble characteristics in a three-dimensional gas fluidized bed. The probe sensor has a major dimension of 1.8 cm, and contains an LED and a photo-cell separated by a gap of 2.5 mm. Coupled with a non-inverting comparator circuit with hysteresis as a noise filter, the probe has been very effective in characterizing the size distribution, shape and velocity of gas bubbles.

A 96 liter rectangular fluidized bed was used, containing glass beads with a size fraction of 355μ to 250μ . Air was the fluidizing medium, with gas velocities ranging from $1.2 U_{mf}$ to $2 U_{mf}$. The probe position was varied from 35 to 55 cm above the distributor, and 0 to 8 cm from the bed centerline. The bubble size distribution was fit to a truncated gamma function. It was also found that the Davies-Taylor Equation for bubble velocity was inadequate to fit the data, since the velocity varied significantly with the position in the bed.

Motion pictures were also taken in a two-dimensional bed to obtain qualitative information on bubble characteristics.

ACKNOWLEDGMENTS

The author wishes to express his deepest appreciation to all of the people who have provided advice and support in his research and in the preparation of this dissertation. To the Chairman of the Graduate Committee, Dr. Angelo Perna, a very special acknowledgment is extended for his personal interest, advice and support in the author's research. For this the author is deeply indebted. To Dr. Ching-Rong Huang, a member of the Graduate Committee, who has provided useful suggestions in the preparation of this dissertation, the author is sincerely grateful. While the author greatly appreciates the assistance of Dr. Jay Kappraff, Dr. Gordon Lewandowski and Dr. Wing Wong for their contributions and serving on the Graduate Committee, he also wishes to thank Mr. Gregory Ciurpita for his assistance with the fabrication of the electronic apparatus. Finally, the author wants to express his gratitude to his fiancée, without her inspiration and assistance the author's graduate study would never have been a success.

TABLE OF CONTENTS

	Page
LIST OF TABLES	v
LIST OF FIGURES	vi
NOMENCLATURE	ix
Chapter	
I INTRODUCTION	1
II INSTRUMENTATION AND PROBING TECHNIQUE	9
Instrumentation	9
Probing Technique	13
Bubble Velocity	17
Bubble Size and Shape	19
Bubble Frequency	34
III EXPERIMENTAL FACILITY	35
Two-Dimensional Fluidized Bed	35
Three-Dimensional Fluidized Bed	38
Bed Material	38
Probe Positioning Mechanism	42
Air Supply and Humidification System	42
Photographic Equipment and Supplies	44
Power Supply System	44
IV EXPERIMENTAL PROCEDURES	46
Qualitative Investigation	46
Quantitative Investigation	46

Chapter	Page
V	RESULTS AND DISCUSSION 48
	Qualitative Investigation 48
	Quantitative Investigation 52
	Bubble Shapes 52
	Bubble Velocity 52
	Bubble Size Distribution 54
	Bubble Frequency Distribution. 63
VI	CONCLUSION 70
VII	RECOMMENDATIONS 72
	REFERENCES 73
	APPENDIX
	A. COMPUTER AIDED CALCULATION OF BUBBLE CHARACTERISTICS 77
	B. SOFTWARE SIGNAL DISCRIMINATOR AND PROCESSOR 83
	C. DESCRIPTION OF CALIBRATION PROCEDURE FOR COMPARATOR CIRCUIT 90
	D. DATA COLLECTED FOR BUBBLE CHARACTERISTICS ANALYSIS 96

LIST OF TABLES

<u>Table</u>	<u>Page</u>
1. Logical voltage sequence generated by probe when a bubble center rising along the probe vertical axis	18
2. The glass bead sizes used in the 2-D fluidized bed	41

LIST OF FIGURES

<u>Figure</u>	<u>Page</u>
1. Schematic representation of the bulk gas-flow pattern in bubble-region and grid-region of fluidized beds	3
2. Photograph of a two-dimensional bubble	5
3. Schematic diagram of 3-D probe	10
4. The comparator circuit for signal processing	12
5. Schematic diagram of timer circuitry	14
6. Block diagram of the set-up for on-line monitoring of bubble characteristics	15
7. An ideal signal sequence generated by a bubble whose center rising along the probe vertical axis	16
8. An ideal 3-D bubble rising through a 3-D probe	20
9. A spherical cap bubble with its axial length greater than its superficial radius and an indented bottom	23
10. A spherical cap bubble with its axial length greater than its superficial radius and a flat bottom	25
11. A spherical cap bubble with its axial length less than its superficial radius and an indented bottom	26
12. A spherical cap bubble with its axial length less than its superficial radius and a flat bottom	28
13. A semi-spherical bubble with a flat bottom	29
14. A semi-spherical bubble with an indented bottom	31
15. A paraboloid bubble with a flat bottom	32

<u>Figure</u>	<u>Page</u>
16. A paraboloid bubble with an indented bottom	33
17. Schematic diagram of the 2-D fluidized bed .	36
18. Photograph of the 2-D fluidized bed set-up .	37
19. Photograph of the 3-D fluidized bed set-up .	39
20. Schematic diagram of the gas distributor of the 3-D fluidized bed	40
21. Flow diagram of the air supply and humidification system	21
22. A cine sequence of bubbles coalescence phenomenon	50
23. A cine sequence of a bubble splitting . . .	51
24. Typical measured bubble shapes	53
25. Variation of bubble velocity with equivalent spherical diameter for individual bubbles in the fluidized bed	55
26. Variation of mean bubble velocity with bubble size and level in the bed on the bed centreline	56
27. Variation of mean bubble velocity with size and lateral position at the top of the fluidized bed	57
28. Typical measured bubble size distribution with gamma-function distribution analytical fit	58
29. Typical bubble size distribution reported by the probe together with gamma function distribution fit	60
30. Variation of the gamma function bubble size distribution with vertical level in the fluidized bed on the bed centreline	61

<u>Figure</u>	<u>Page</u>
31 Variation of the gamma function bubble size distribution with vertical level in the fluidized bed at 8cm distance from bed centerline	62
32. Variation of size distribution with lateral position at the top of the fluidized bed . .	64
33. Variation of size distribution with lateral position at the middle of the fluidized bed	65
34. Variation of mean bubble size distribution in the bed at different position	66
35. The changes in the size distribution variance with position in the fluidized bed	67
36. Variation of bubble frequency with superficial gas velocity and lateral position in the fluidized bed.	68
37. Variation of bubble frequency with position in the fluidized bed	69
38. Schematic diagram of the non-inverting comparator with hysteresis	91
38A An actual amplifier output recorded on a chart	91A
38B An actual comparator output without the hysteresis effect.	91B
39. An actual comparator output with the hysteresis effect.	92
40. Input-output characteristic with hysteresis effect	94

NOMENCLATURE

<u>Symbol</u>	<u>Definition</u>
A_L	Bubble Central Vertical Axial Length (cm)
D_B	Superficial Bubble Diameter (cm)
D_E	Bubble Spherical Equivalent Diameter (cm)
d	Distance Between Sensors on Probe Vertical Axis (cm)
d_e	Truncated Bubble Spherical Equivalent Diameter (cm)
\bar{d}_e	Mean of Bubble Size Distribution Function
d_r	Distance Between Sensors on Probe Transverse Axis (cm)
F_D	Distance to Bubble Frontal Surface at Radial Distance d_r (cm)
H	Height of Indentation (cm)
H_W	Height of Wake (cm)
k	Parabolic Constant
L_2	Bubble Vertical Chord Length at Radial Distance d_r (cm)
R_B	Superficial Bubble Radius (cm)
R_F	Radius of Curvature of Bubble Frontal Surface (cm)
R_W	Radius of Curvature of Bubble Wake Surface (cm)
r	Radius of Bubble Base (cm)
T_1	Pulse #1 Duration Time (Number of Time Intervals)
T_2	Pulse #2 Duration Time (Number of Time Intervals)

<u>Symbol</u>	<u>Definition</u>
T_3	Pulse #3 Duration Time (Number of Time Intervals)
T_4	Pulse #4 Duration Time (Number of Time Intervals)
T_{D1}	Delay Time Between Pulse #2 and Pulse #4 (Number of Time Intervals)
T_{D2}	Delay Time Between Pulse #2 and Pulse #3 (Number of Time Intervals)
t	Time (sec)
U_B	Bubble Velocity (cm/sec)
\bar{U}_B	Mean Bubble Velocity (cm/sec)
U_g	Superficial Gas Velocity (cm/sec)
U_{mf}	Minimum Fluidization Velocity (cm/sec)
V_B	Bubble Volume (cm ³)
V	Signal Voltage (volt)
V_H	Signal Voltage at High
V_L	Signal Voltage at Low
V_R	Reference Voltage of Comparator
Z_v	Vertical Distance Above Gas Distributor (cm)
Z_1	Lateral Distance From Bed Centerline (cm)
$\Gamma(x)$	Gamma Function of x
α	Scale Parameter of Gamma Function Distribution
β	Shape Parameter of Gamma Function Distribution
δ	Truncate Error (cm)
σ_{de}^2	Variance of Bubble Size Distribution

<u>Symbol</u>	<u>Definition</u>
	Standard Deviation of Mean Bubble Velocity
R_a	Adjustable Attenuator Resistance
R_b	Bias Resistance
R_f	Feed Back Resistance
R_i	Input Resistance
R_{ref}	Adjustable Reference Resistance
V_{H1}	High Limit of Hysteresis Window Width
V_{H2}	Low Limit of Hysteresis Window Width
V_i	Input Voltage Before Attenuator
V_i'	Input Voltage After Attenuator
V_i''	Feed Back Voltage
V_{ref}	Reference Voltage

Chapter I

INTRODUCTION

The beginning of the fluidized bed can be traced back to the Winkler gas generator nearly sixty years ago. It is the first patented large-scale fluidized-bed coal gasifier¹ although the nomenclature is hardly recognizable. At present there is a tremendous amount of literature covering the fluidization theory, bubble phenomena and heat and mass transfer. It has not only been applied to chemical and petroleum industries but also has found application in energy and environmental industries, and in many other fields requiring various solid-handling techniques.

In spite of this long history, the enormous research and development effort and extensive application of fluidization technique, many fluidized beds have been rather less than successful. Only in the last few years have some of the reasons for earlier failures become apparent with one of the most common causes being the lack of complete understanding of the complex hydrodynamics of solids and fluids within the fluidized beds.

Almost all gas solid fluidized beds operate with bubbles in the bed. Only under one circumstance, the ratio of bed solid density to fluidizing medium density

is less than about 10, there will be no bubble appearance². The position, size, shape and velocity of bubbles in the bed determine how both solid and gas will move. The bubbles also determine the heat transfer properties at the walls and gas-solid exchange coefficients. Thus the design of a gas fluidized bed for most industrial purposes requires the knowledge of the bubble characteristics, although the bubble cannot normally be seen deep in the interior.

The first appearance of gas in a fluidized bed is not in the form of bubbles, but in the form of jets as shown in Figure 1. Then, bubbles erupt from the jets formed at the distributor which supports the fluidized bed. In the study of fluidized bed characteristics, the region near the distributor called the distributor-region or grid-region is sometimes treated separately from the higher position of the bed called bubble-region, since these two regions have distinct differences in characteristics in many respects³. For example, bubbles are rather uniform in size at the grid-region and as they rise higher along the bed the size variation becomes greater. Since bubble size in the grid-region is much smaller than the size higher up in the bed, gas exchange between bubble phase and emulsion phase is vigorous, resulting in a high gas-solid contact efficiency.

Various methods have been adopted by investigators for measuring the bubble size, shape, frequency and velocity

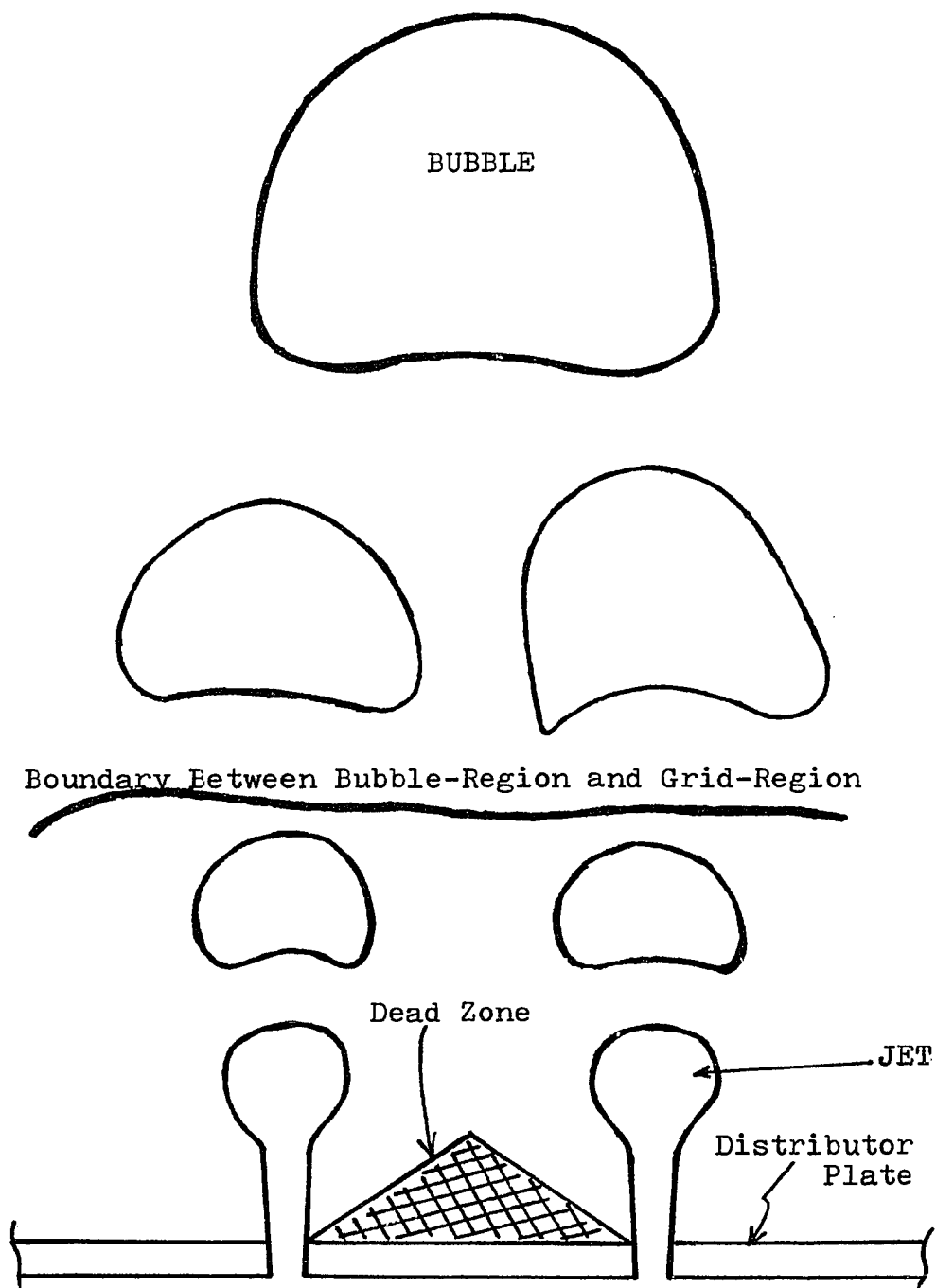

Figure 1. Schematic representation of the bulk gas-flow pattern in bubble-region and grid-region of fluidized beds.

in the bubble region of fluidized beds. Practically all of the methods for bubble characteristics measurement in fluidized beds have fallen into one of the following categories:

- (a) Photography
- (b) X-ray and γ -ray techniques
- (c) The use of probes.

Photography is essentially limited to two-dimensional (2-D) beds in which the bubbles span the thickness of the beds and are therefore clearly visible^{4,5,6,7}. Figure 2, a photograph of a 2-D bubble, shows the size and shape of the bubble. When studying three-dimensional (3-D) beds photographic methods are severely limited. Another limitation is the shape of a two-dimensional bubble may not be the same as a three-dimensional bubble under the same bed operating conditions.

X-ray cine photography probably gives the most direct and unambiguous information of actual bubble characteristics. Some successful observations have been made of the behavior of the bubbles in the interior of 3-D beds by the use of X-ray photography^{8,9,10}. A method based upon the absorption of γ -rays has also been used^{11,12}. However, the use of both X-rays and γ -rays involves complex equipment and shielding and are confined to relatively small beds under laboratory conditions. A large bed would have resulted in an extremely long detection path for external X- and γ -ray

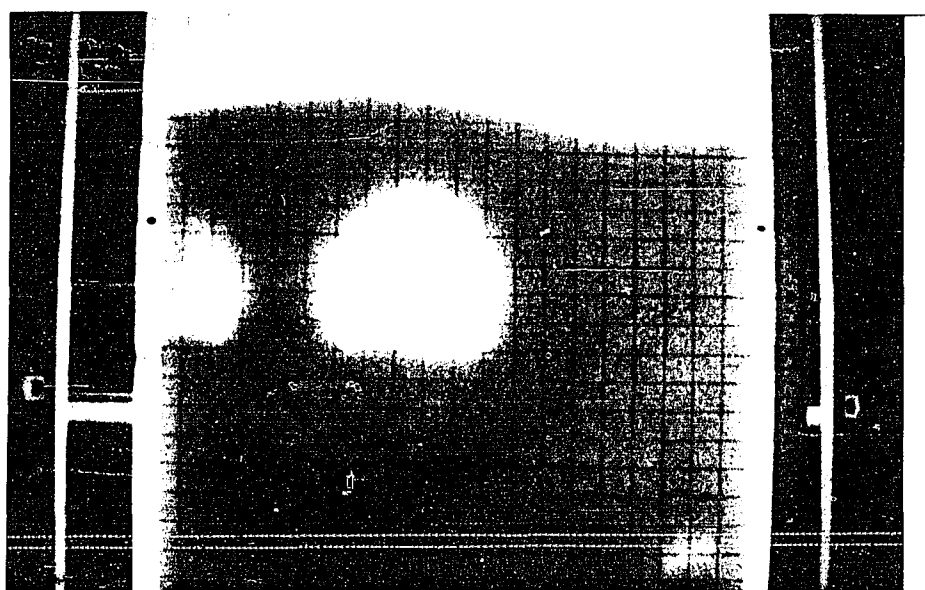

Figure 2. A photograph of a two-dimensional bubble.

techniques and absorption probably would have been too high. Under certain circumstances the number of overlapping bubbles in such a bed could also be unacceptably large.

For large beds and those operating under industrial conditions the only practical means of observation is by probes. Thus, the most popular technique for the study of the bubble is probably the probing technique.

There are four kinds of probes usually used to study bubble characteristics in gas fluidized beds, namely, (a) conductance probe, (b) inductance probe, (c) capacitance probe, and (d) optical probe. The signals they generate can be processed and interpreted in a variety of ways but they also have their own limitations. A common uncertainty exists in these probes in deciding the bubble size and velocity distribution at a point in the bed due to the unpredictable positions at which the probe contacts the bubble frontal surfaces.

In general, conductance probes are limited in their applicability to liquids and relatively more conductive solids. Fluidized coke particles conduct electricity well thus allowing electrical resistivity to be used to indicate the presence of bubbles in a fluidized coke bed^{13,14,15,16}.

Capacitance probes have been used by more investigators than the other kinds, presumably because they work well with nonconducting materials such as sand and glass beads which are commonly used in laboratory fluidized

beds. However, capacitance probes have four major disadvantages. The wires that are connected to the capacitor need to be limited in length in order to avoid the unusually high noise in the probe response^{17,18,19,20}, this restricts their applicability in large or deep fluidized beds. The second disadvantage is the need for an extremely sophisticated and expensive instrumentation^{21,22,23}. Exhaustive calibrations of the probe for each solid-fluid system and possible for every operating condition, particularly temperature and pressure, is the third disadvantage. The fourth disadvantage is the probe may be too large in dimensions for undisturbed measurements in a fluidized bed^{24,25,26,27}.

An inductance probe requires the bed materials to be susceptible to a magnetic field. Cranfield devised a small probe with a tip that functions rather like a head on a magnetic tape recorder²⁸. The probe can be used to detect the presence of ferromagnetic articles. When the bed consists of particles with ferromagnetic properties, the signal at the probe is a direct indication of whether a bubble or the emulsion phase is present.

Optical probes suffer very little from previous probes mentioned shortcomings and are thus the most versatile in application. Yasui and Johanson²⁹, Winter³⁰ and Yoshida³¹ measured the presence of bubbles by light transmission. The articles from Winter made use of fiber optics bundles and the work Yasui and Johanson used quartz rods.

With all this, there is a need for a more exhaustive collection and analysis of data on the bubble characteristics of fluidized beds for a more precise understanding of many fluidization phenomena. Our current knowledge on bubble characteristics is mostly based on a limited number of data collected in small laboratory units. In addition to this, it is also necessary to continuously or periodically monitor the bubble behaviors of many industrial fluidized bed reactors for a better control and operation of such units.

An optical probe, derived from S. Dutta and C. Y. Wen's design³², is devised and a new probing technique and instrumentation are developed from this investigation. This new probing system which overcomes most of the previously mentioned disadvantages and permits on-line monitoring of all major bubble characteristics continuously and simultaneously.

Chapter II

INSTRUMENTATION AND PROBING TECHNIQUE

INSTRUMENTATION

To remove some uncertainties and disadvantages associated with existing techniques and develop a device which gives accurate bubble sizes, shapes, velocities and frequencies in a fluidized bed the following conditions must be satisfied:

1. The probes must be capable of telling whether the center of a striking bubble is rising up along the probe's vertical axis.
2. The timing of the bubble reaching and leaving the probe must be accurately determined.

In order to achieve the first goal, a three-dimensional optical probe is designed. The construction details of the 3-D probe are shown in Figure 3. There are four tiny lights emitting diodes (Motorola LED-50) on the probe which acts as a light source. The four sensing elements are LS-400 photo-cells of about 1 mm in diameter and 8 mm in length. One LED matches one photo-cell to form a sensor. For all sensors, LED and photo-cells are separated from each other by a distance of about 2.5 mm. The distance between

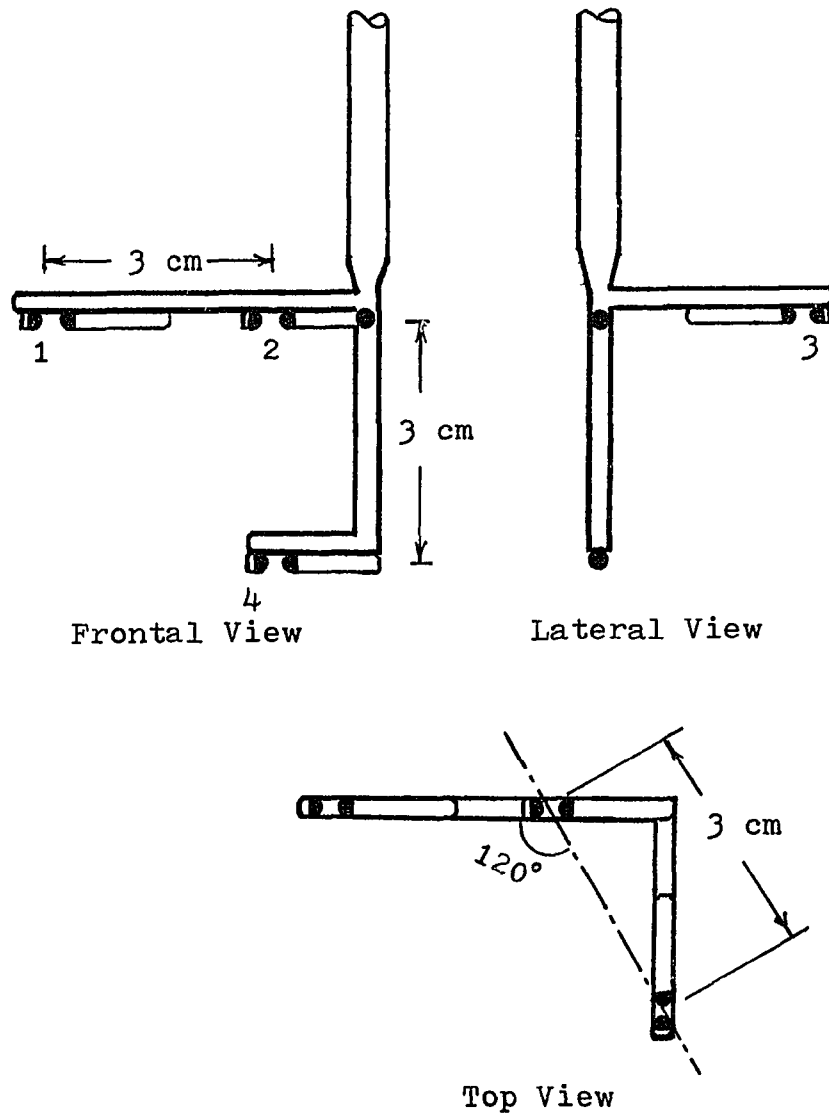

Figure 3. Schematic diagram of 3-D probe.

each sensor is 3 cm. LED and photo-cells are glued on the stainless steel frame and coated with epoxy to increase its strength. The probe is connected so that each sensor forms part of an electrical circuit whereby current flows from an external D.C. power supply. While a sensor resides in the transparent phase it will develop a voltage across the photo-cell and thus generate a signal.

The two sensors which are not lined up on the probe's vertical axis are used to judge whether the striking bubble is rising up along the probe's vertical axis. If a bubble is rising along the probe's vertical axis, the signals generated by those two sensors which are not lined up on the probe's axis should be the same.

To achieve the second goal, a comparator circuit with an adjustable reference level as shown in Figure 4 is developed. LM339 quad comparator has four independent voltage comparators in a single package. This is merely a coincidence with the four channel probe. The comparator circuit is used to obtain an almost perfectly square wave form. Generation of square waves is necessary for on-line analysis of the data by a microprocessor. Square waves are also much easier to analyze manually.

The probe assembly is the combination of the probe and the comparator circuits. This device has been coupled to an INTEL 8085 microprocessor with timer circuitry for fast, accurate conversion of analog voltage signals to binary digits and with software to discriminate the signals

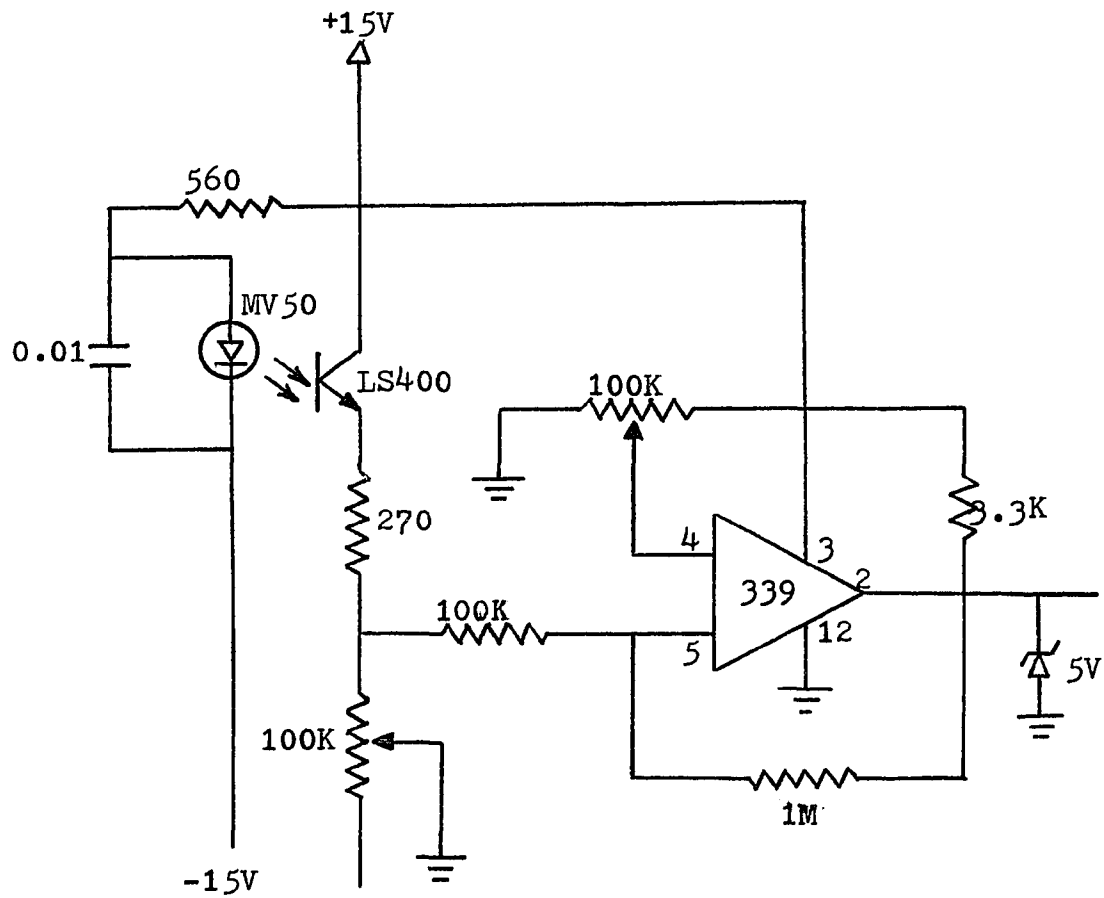

Figure 4. The comparator circuit for signal processing.

generated by the bubbles whose rising path is not coincident with the probe's axis. The software discriminator selects only those bubbles whose centers are rising along the probe's axis and displays all of the information deemed necessary for calculations of bubble size, shape, velocity and frequency. Then, the Univac 90/80-4 computer is programmed to do all of the calculations. The timer circuitry is shown in Figure 5. It is a combination of four 8253 programmable interval timers with some logic gates and resistors. The interval is set to be 2 milliseconds. The Figure 6 shows a block diagram of this whole system, and further details are given in Appendix A, B and C.

Probing Technique

The probing technique may be illustrated by considering the voltage pulse sequence which is generated by a bubble which is rising through the probe. An arbitrary reference voltage for comparator circuits is defined as

$$V_L < V_R < V_H \quad (1)$$

If all sensors enter a bubble and thus develop a voltage across the photo-cells which is higher than the reference voltage V_R , the signals should be at a high and vice versa. An ideal sequence generated by the probe when a bubble center is rising along the probe's vertical axis is shown in Figure 7, where the pulses are numbered with

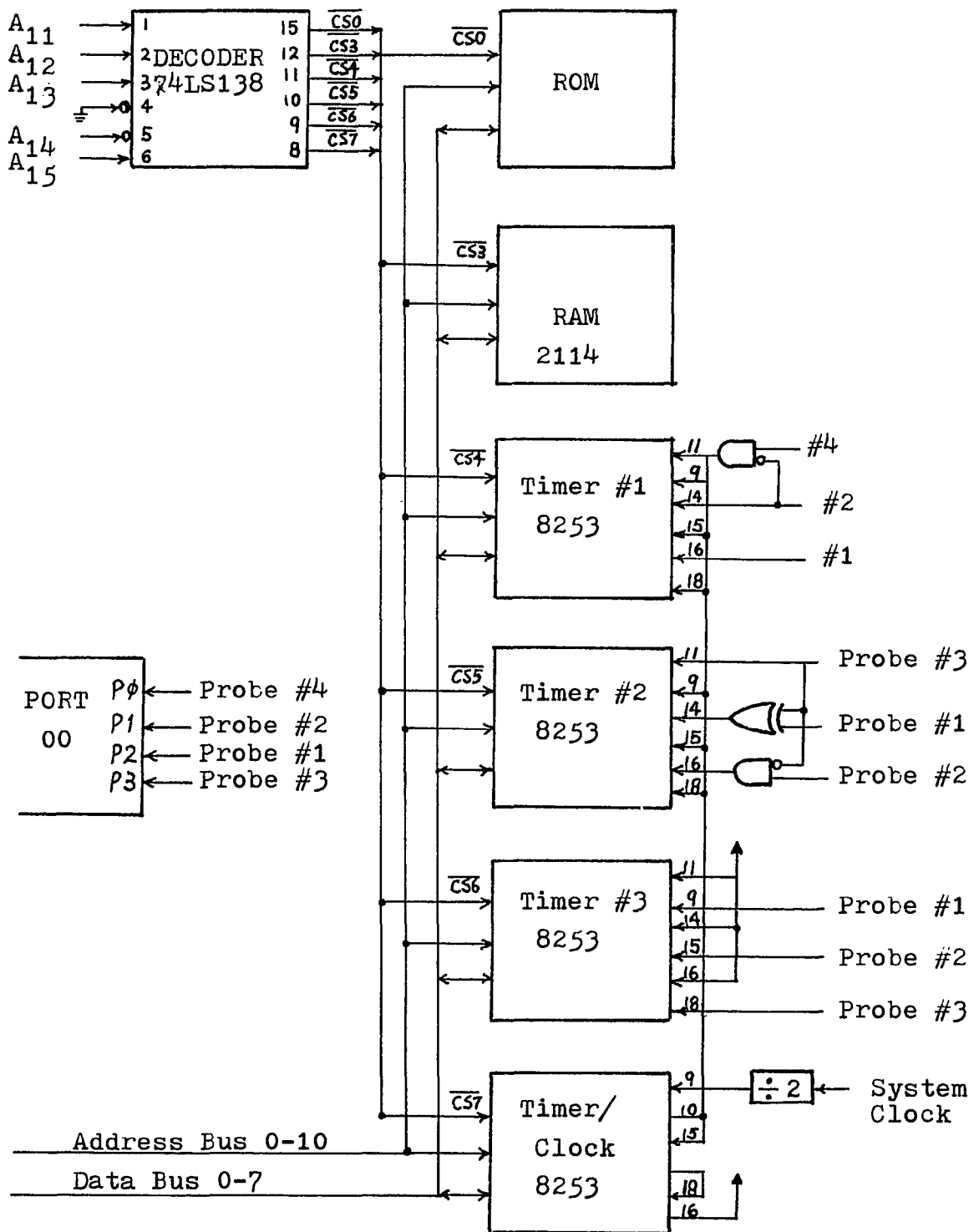

Figure 5. Schematic diagram of timer circuitry.

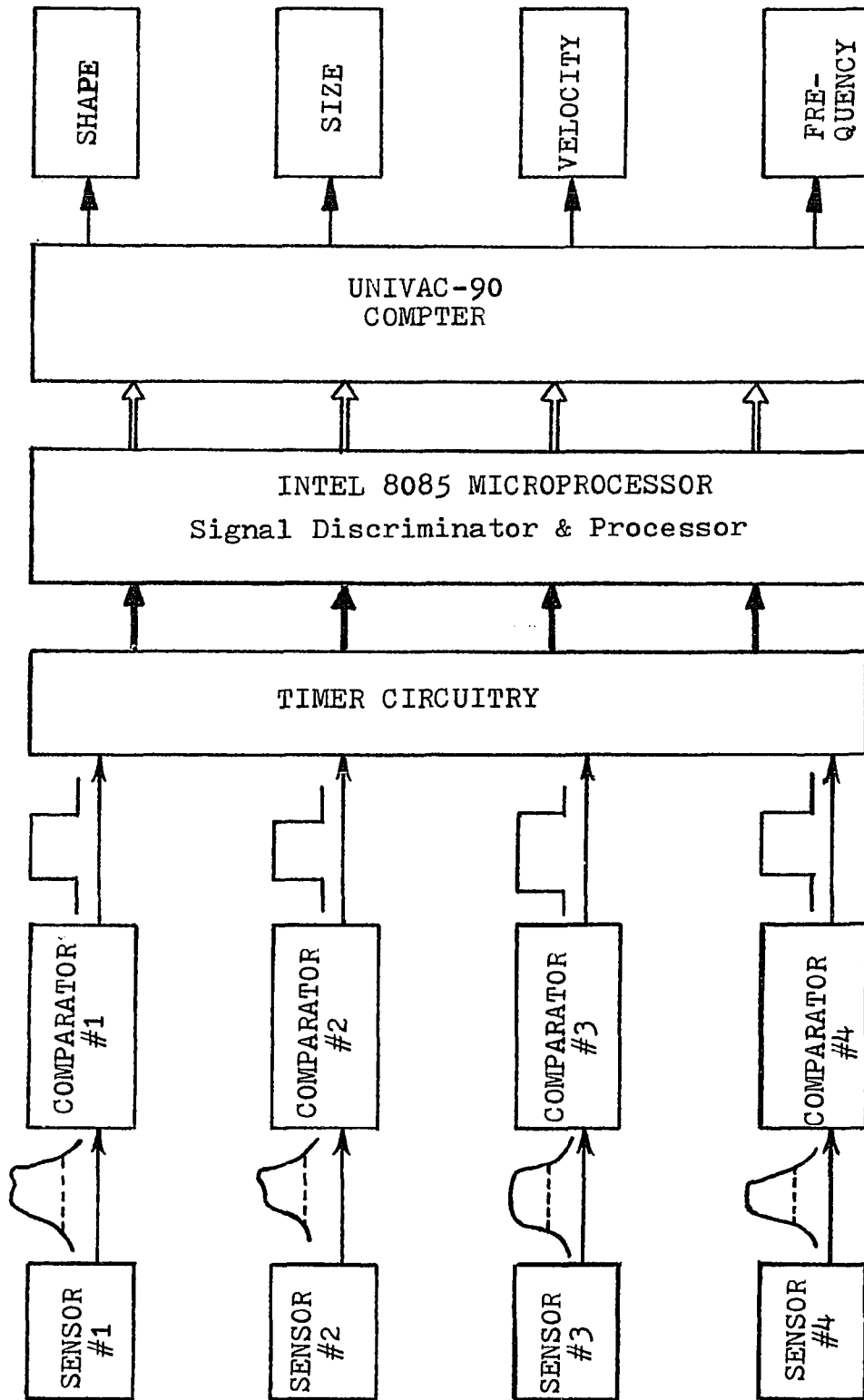

Figure 6. Block diagram of the set-up for on-line monitoring of bubble characteristics.

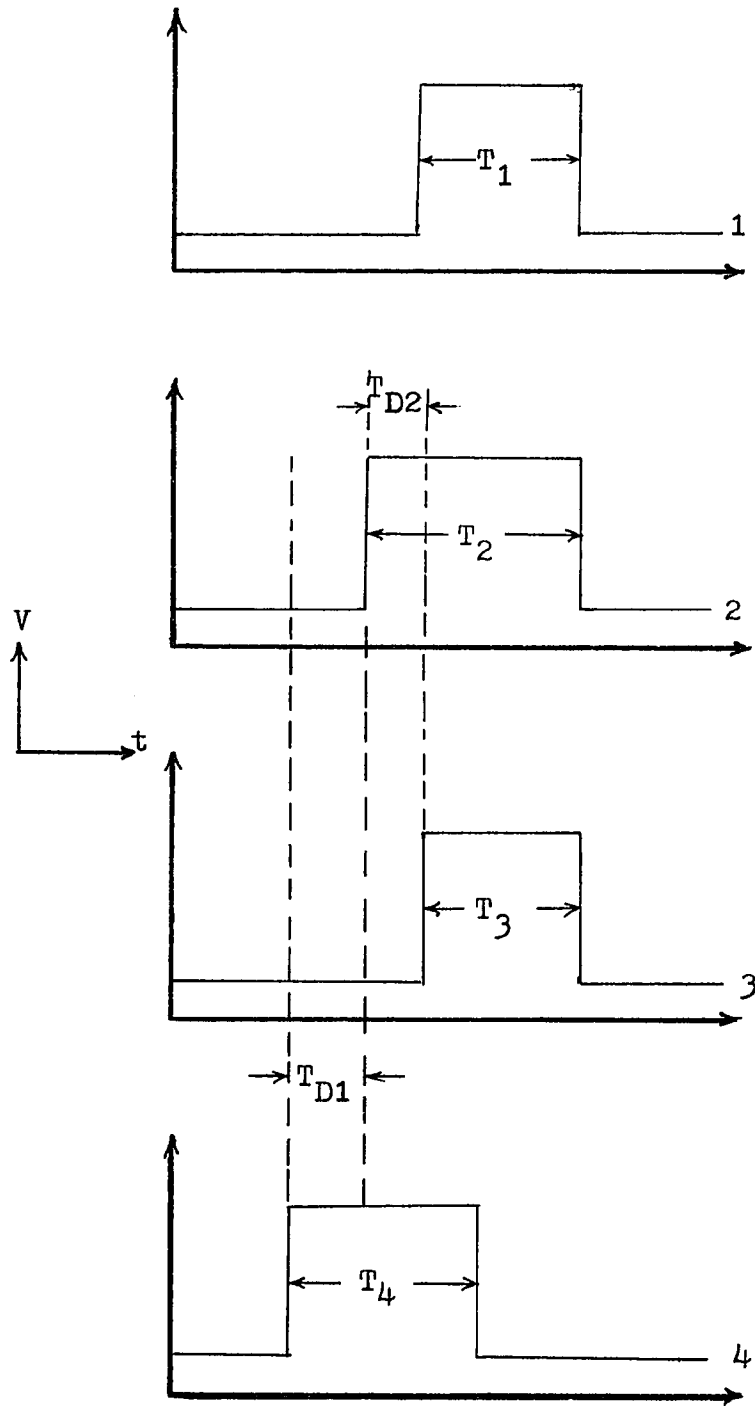

Figure 7. An ideal signal sequence generated by a bubble whose center rising along the probe vertical axis.

reference to the number of the sensors shown in Figure 3. Figure 8 shows that an ideal 3-D bubble is rising through a probe. The voltage sequence generated by the probe should follow the eight steps which are shown in Table 1. Based on these logical steps shown in Table 1, the software signal discriminator has been developed and shown in Appendix B. If the signal sequence is not following the eight logical steps, the signals will be deleted. Thus all the timers will be reset and ready for the next sequence coming in. If the signal sequence follows the eight steps in Table 1, the last thing needed to be checked is whether the signal sequence has been generated by a single bubble. Only the center of a single bubble rising along the probe's axis will show

$$T_1 < T_2 \quad (2)$$

and

$$T_3 < T_2 \quad (3)$$

where T_1 , T_2 and T_3 are defined in Figure 7.

Bubble Velocity

The time delay T_{D1} is defined in Figure 7. For an accurately known distance (d) between sensor #2 and sensor #4, defined in Figure 3, the bubble velocity is given by

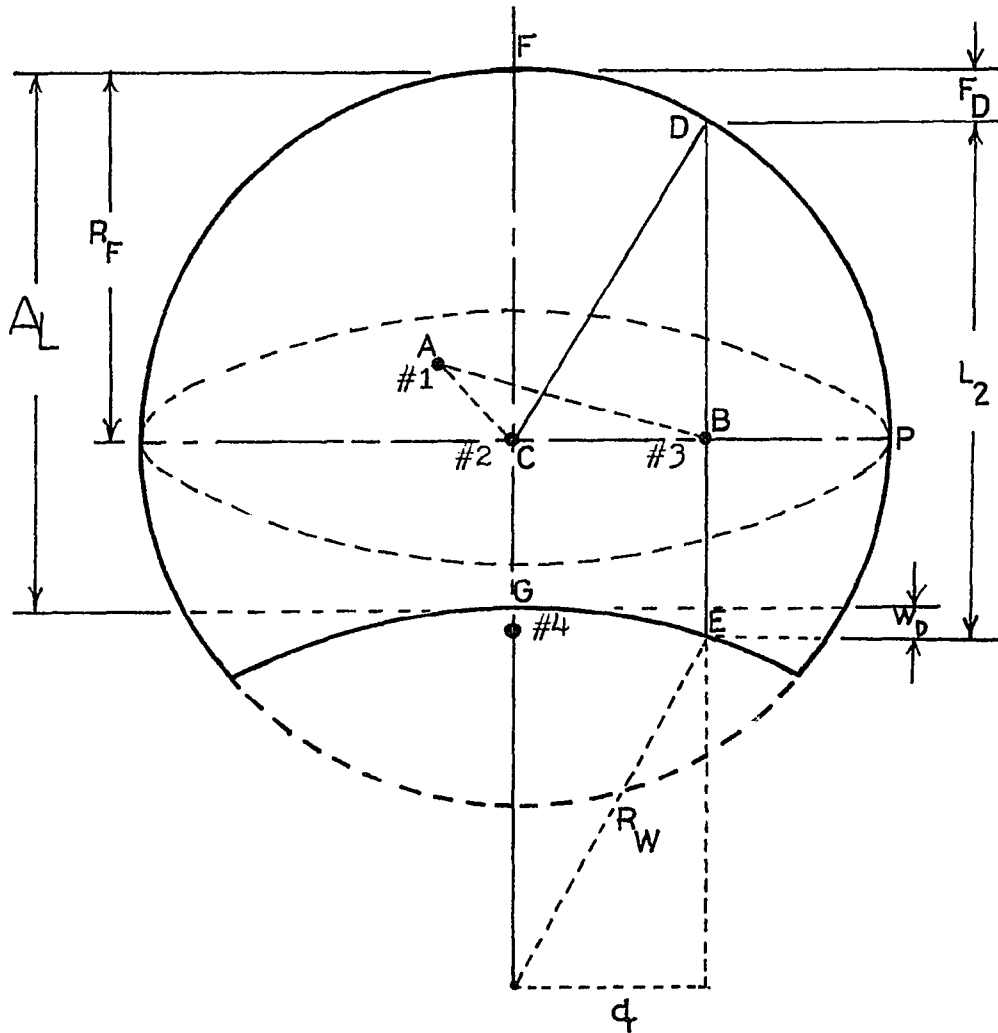

Figure 8. An ideal 3-D bubble rising through a 3-D probe.

Table 1

Probe Signal Sequence Generated by a Single
Bubble Whose Center Rising Along the Probe Axis

Step	Channel 1	Channel 2	Channel 3	Channel 4
1	V_L	V_L	V_L	V_L
2	V_L	V_L	V_L	V_H
3	V_L	V_H	V_L	V_H
4*	V_L	V_H	V_H	V_H
5	V_H	V_H	V_H	V_H
6	V_L	V_H	V_H	V_L
7	**	**	**	**
8	V_L	V_L	V_L	V_L

Notes: * Either Channel 1 at V_L and Channel 3 at V_H
or Channel 1 at V_H and Channel 3 at V_L
** Either V_H or V_L

$$U_B = \frac{d}{T_{D1}} \quad (4)$$

Bubble Size and Shape

The central vertical length of a bubble is given by

$$A_L = U_B \cdot T_2 \quad (5)$$

where T_2 is defined in Figure 7. The time delay T_{D2} is also defined in Figure 7. Thus, the elevation difference between the center of the bubble frontal surface and the bubble surface point at a lateral distance d_r from the bubble vertical axis is given by

$$F_D = U_B \cdot T_{D2} \quad (6)$$

The bubble vertical chord length at a lateral distance d_r from bubble vertical axis is then given by

$$L_2 = U_B \cdot T_3 \quad (7)$$

The frontal surface of the bubbles are essentially spherical but with an indented base of greater or lesser degree as seen in Figure 2. This is the idealized or perhaps stable shape of an isolated bubble and can often be observed. Then a spherical radius R_F is largely defined from the ideal bubble. According to Figure 8

$$CF = CD = R_F \quad (8)$$

$$CB = d_r \quad (9)$$

$$BD = R_F - F_D \quad (10)$$

and

$$CD^2 = CB^2 + BD^2 \quad (11)$$

or

$$R_F = \sqrt{(R_F - F_D)^2 + d_r^2}. \quad (12)$$

By iteration, R_F can be determined. If the wake surface is also spherical, the radius of the wake surface R_W can be determined by the same method as solving for R_F .

In order to process the data further, a bubble shape determination procedure is developed to select between eight shapes to secure the best fit to the calculated coordinates, A_L , F_D and L_2 .

For a spherical cap bubble

$$A_L < 2R_F \quad (13)$$

and

$$R_B = R_F \quad (14)$$

where R_B is the superficial radius.

A spherical cap bubble with $R_B < (A_L + H_W) < 2R_B$ and a dented bottom is shown in Figure 9. Thus

$$H = 2R_B - A_L \quad (15)$$

$$R_W^2 - (R_W - H_W)^2 = r^2 \quad (16)$$

and

$$R_B^2 - [R_B - (H - H_W)]^2 = r^2 \quad (17)$$

By solving Eq. (16) and (17) the value of r and H_W can be determined. The volume of a sphere is

$$V_1 = \frac{4}{3}\pi R_B^3. \quad (18)$$

The volume occupied by wake in Figure 9 may be calculated by

$$V_2 = \frac{\pi}{6} H_W (3r^2 + H_W^2) + \frac{\pi}{6} (H - H_W) [3r^2 + (H - H_W)^2]. \quad (19)$$

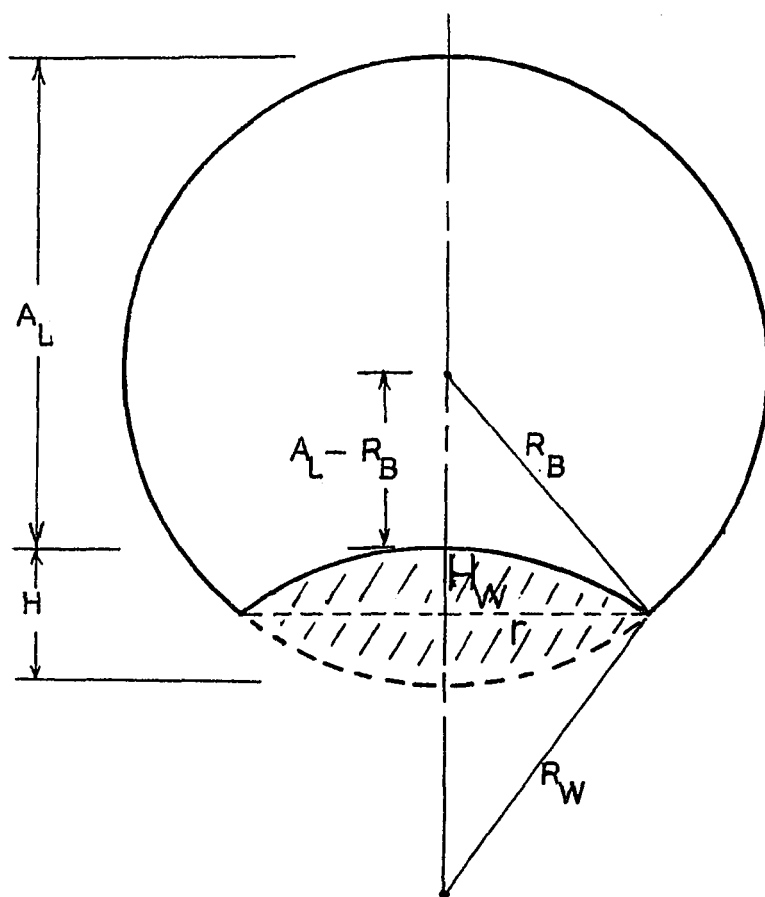

Figure 9. A spherical cap bubble with its axial length greater than its superficial radius and an indented bottom.

Hence, the bubble volume is

$$V_B = V_1 - V_2 \quad (20)$$

For a spherical cap bubble with $R_B < (A_L + H_W) < 2R_B$ and flat bottom, the shape is shown in Figure 10. The volume of the bubble wake is

$$V_3 = \frac{\pi}{6} H_W (3r^2 + H_W^2). \quad (21)$$

Thus, the bubble volume can be determined by equations (18) and (21).

A spherical segment bubble with $(A_L + H_W) < R_B$ and dented bottom is shown in Figure 11. By solving

$$R_B^2 - (R_B - A_L - H_W)^2 = r^2 \quad (22)$$

and

$$R_W^2 - (R_W - H_W)^2 = r^2 \quad (23)$$

simultaneously, the r and H_W can be determined.

The volume occupied by the shaded area becomes

$$V_4 = \frac{\pi}{6} H_W (3r^2 + H_W^2). \quad (24)$$

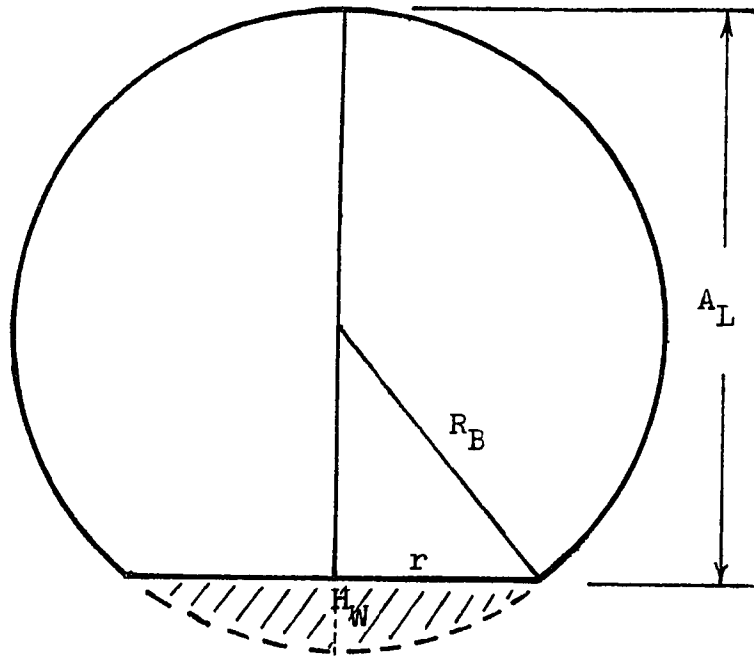

Figure 10. A spherical cap bubble with its axial length greater than its superficial radius and a flat bottom

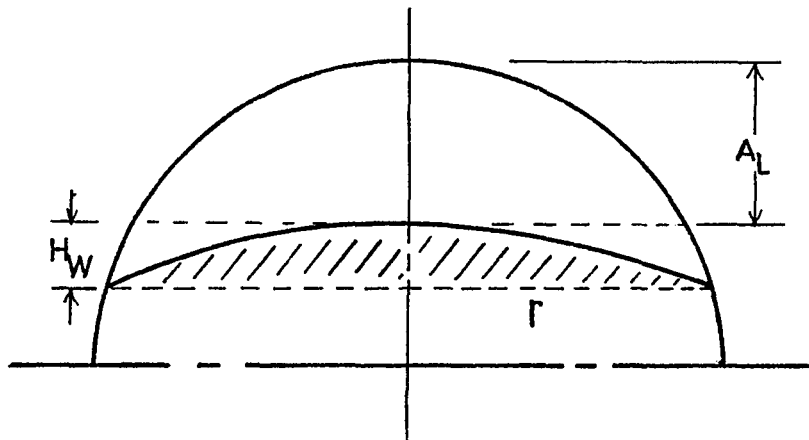

Figure 11. A spherical cap bubble with its axial length less than its superficial radius and an indented bottom.

The volume of the whole spherical segment in the Figure 11 is

$$V_5 = \frac{\pi}{6} (A_L + H_W) [3r^2 + (A_L + H_W)^2]. \quad (25)$$

Thus, the volume of the Bubble is

$$V_B = V_5 - V_4 \quad (26)$$

Figure 12 shows the shape of a spherical segment bubble with a flat bottom and A_L R_B . Where r value can be solved by

$$R_B^2 - (R_B - A_L)^2 = r^2 \quad (27)$$

Then, the bubble volume is

$$V_B = \frac{\pi}{6} A_L (3r^2 + A_L^2) \quad (28)$$

A semi-spherical bubble is shown in Figure 13 where $A_L = R_B$. The volume of this bubble is

$$V_B = \frac{4}{6} \pi A_L^3 \quad (29)$$

Another semi-spherical bubble with a dented bottom

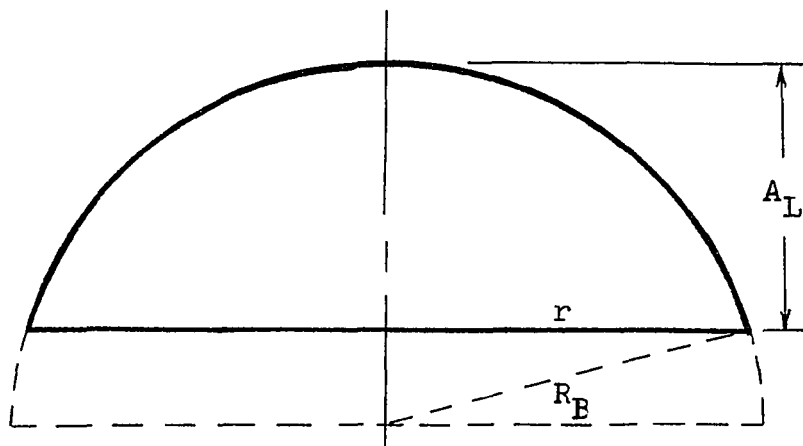

Figure 12. A spherical cap bubble with its axial length less than its superficial radius and a flat bottom.

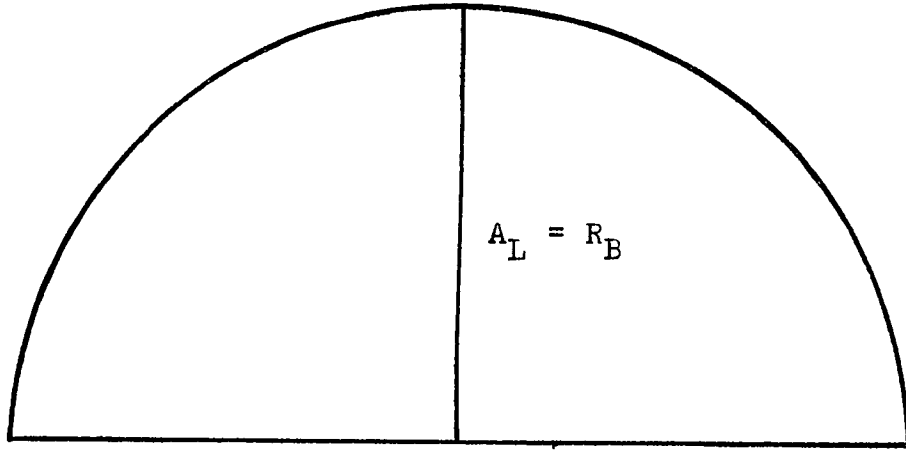

Figure 13. A semi-spherical bubble with a flat bottom.

is shown in Figure 14. The volume of wake becomes

$$V_6 = \frac{\pi}{6} H_W (3R_B^2 + H_W^2) \quad (30)$$

Thus, the volume of this bubble is

$$V_B = \frac{4}{6} \pi R_B^3 - \frac{\pi}{6} H_W (3R_B^2 + H_W^2) \quad (31)$$

When A_L is greater than $2R_F$, the shape of the bubble is like a parabolic body. The Figure 15 shows a parabolic bubble. The bubble volume is

$$\begin{aligned} V_B &= \int_0^{A_L} \pi r^2 \cdot dA_L \\ &= \int_0^{A_L} \pi (kA_L) dA_L \\ &= \frac{k\pi}{2} A_L^2 \end{aligned} \quad (32)$$

A parabolic bubble with a dented bottom is shown in Figure 16. By solving

$$k(A_L + H_W) = r^2 \quad (33)$$

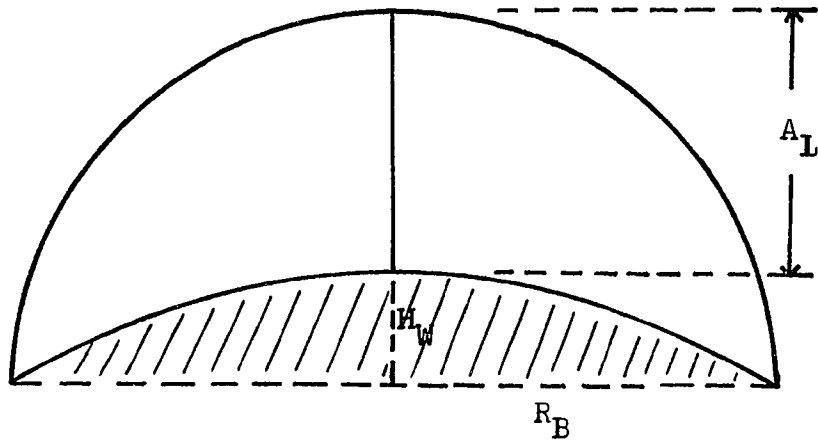

Figure 14. A semi-spherical bubble with an indented bottom.

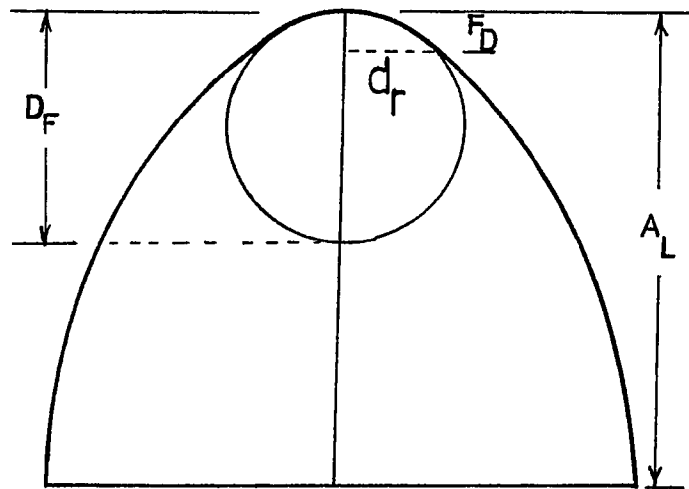

Figure 15. A paraboloid bubble with a flat bottom.

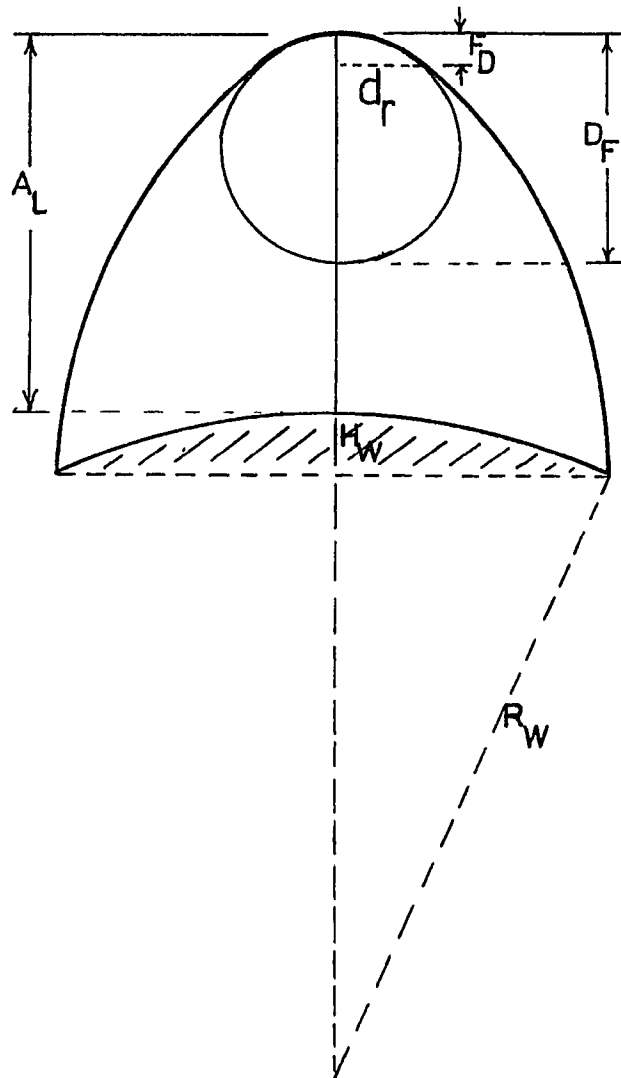

Figure 16. A paraboloid bubble with an indented bottom.

and

$$R_W^2 - (R_W - H_W)^2 = r^2 \quad (34)$$

simultaneously, the H_W and r can be calculated. Thus, the volume of this bubble becomes

$$V_B = \frac{k\pi}{2} (A_L + H_W)^2 - \frac{\pi}{6} H_W(3r^2 + H_W^2) \quad (35)$$

Once the bubble volume is determined, the equivalent spherical bubble diameter can be calculated by

$$D_E = \left[\frac{6V_B}{\pi} \right]^{1/3}. \quad (36)$$

Bubble Frequency

Bubble frequency is defined in terms of the number of bubbles passing through the #2 sensor per second at certain positions within a fluidized bed.

The system can examine all four channels of analogic signals at a rate of 1.1 KH_z which is sufficient to resolve bubble velocity up to 2 m/s with a 3 cm distance between sensor #2 and #4. The bubble characteristics calculation program is shown in Appendix A. The assembly language signal discriminator with frequency counter program and signal processing program are all shown in Appendix B.

Chapter III

EXPERIMENTAL FACILITY

The experimental facility used in this investigation consists of eight primary components, namely, (1) probe assembly and signal processing device, (2) two-dimensional fluidized bed, (3) three-dimensional fluidized bed, (4) bed materials, (5) probe positioning mechanism, (6) air supply and humidification system, (7) photographic equipment and supplies, and (8) power supply systems. Detailed design of the probe assembly, timer circuitry and signal discriminator have been given in Chapter II precisely. In this chapter the remaining seven components are being described.

Two - Dimensional Fluidized Bed

For the qualitative investigation of bubble characteristics by cine photography a transparent 2-D bed is used. The 2-D bed is made of 1.27 cm thick plexiglas plates. The exact dimensions of a bed are given in Figure 17. Figure 18 shows a photograph of 2-D fluidized bed. The gas distributor is a 1.905 cm thick aluminum plate with a single row of 0.3175 cm-diameter holes at a 1.5 cm center to center spacing.

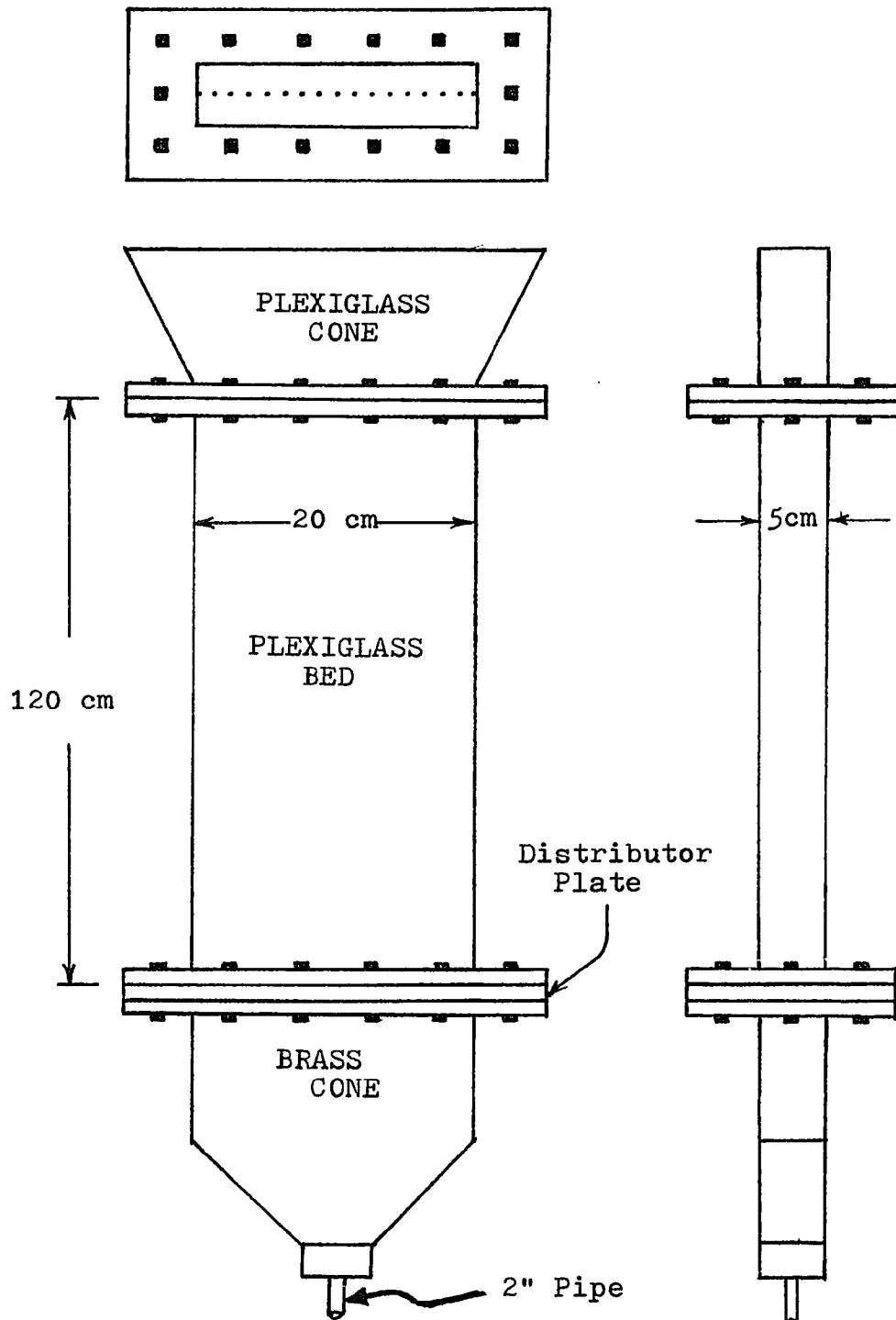

Figure 17. Schematic diagram of the 2-D fluidized bed.

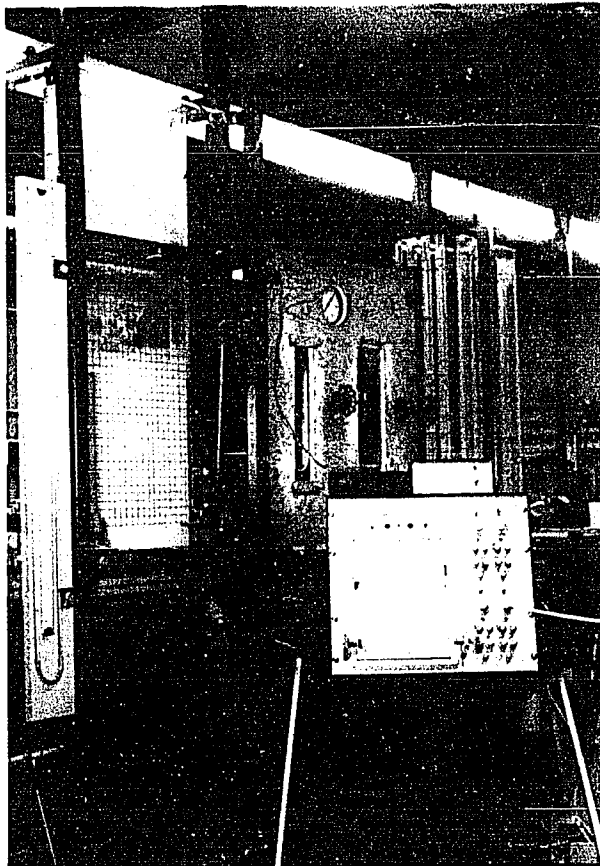

Figure 18. A photograph of the 2-D fluidized bed set-up.

Three-Dimensional Fluidized Bed

A 3-D bed is used for the quantitative study of the bubble characteristics by probe. Figure 19 shows the 3-D fluidized bed with 40 cm x 20 cm x 120 cm in dimensions and made of 1.27 cm thick plexiglass plates. The gas distributor is a perforated and 1.905 cm thick aluminum plate. Its detailed design is shown in Figure 20.

Bed Material

The solid used in this research is Potter Industries Inc., P series glass beads. The sizes of the glass beads used in 2-D bed are given in Table 2.

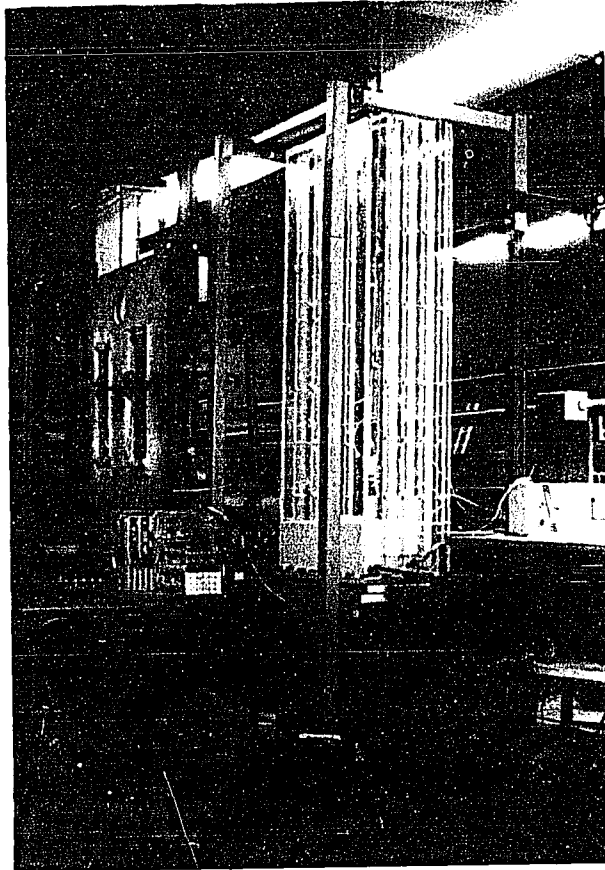

Figure 19. A photograph of the 3-D fluidized bed set-up.

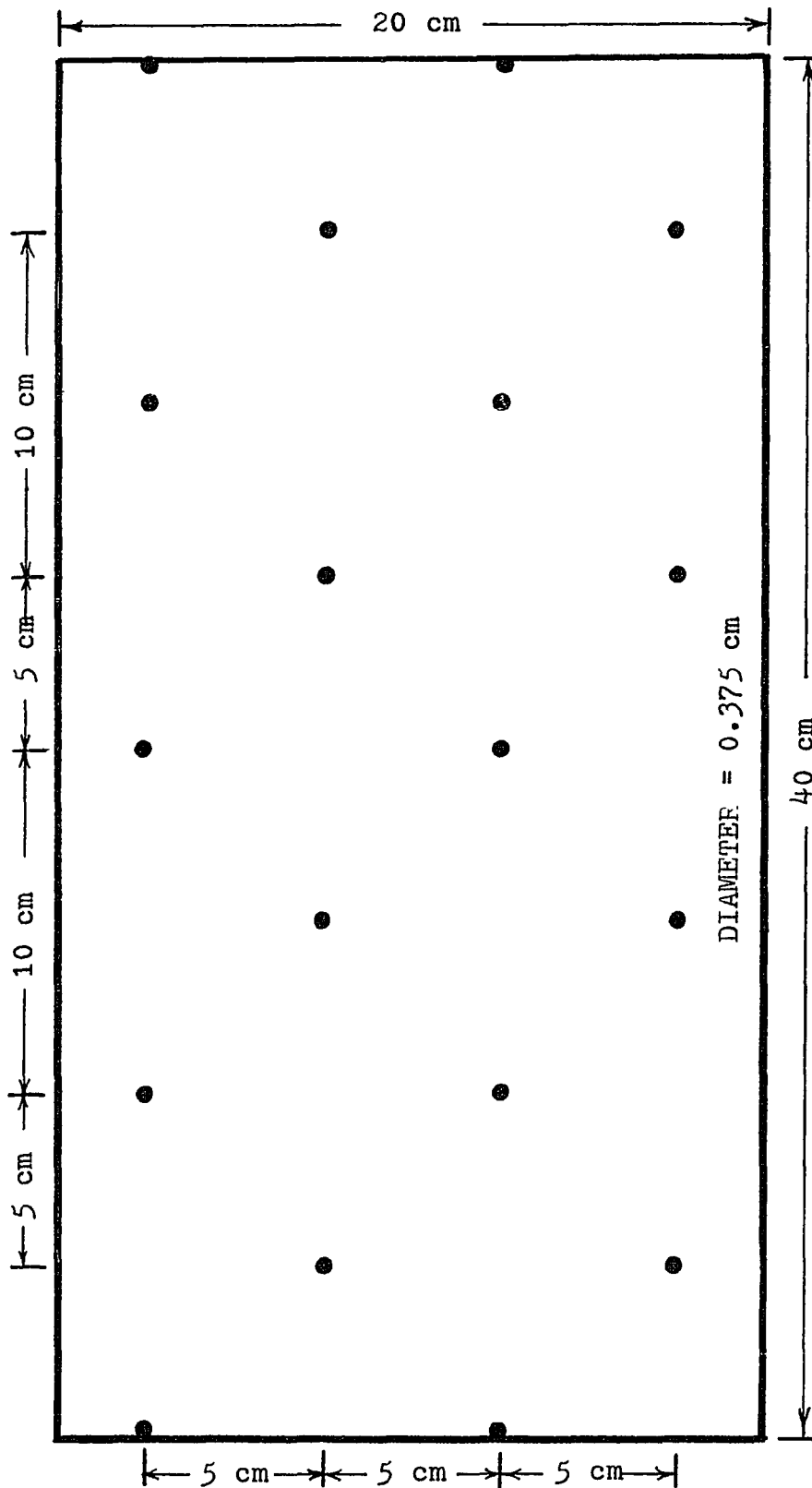

Figure 20. Schematic diagram of the gas distributor of the 3-D fluidized bed.

Table 2

The Glass Bead Sizes Used
in 2-D Fluidized Bed

Solid	Size (μm)
P - 047	1180 - 710
P - 033	850 - 500
P - 0230	600 - 425
P - 0140	355 - 250
P - 004	106 - finer

Only the glass beads with one size of 355 - 250 μm are used in 3-D fluidized bed.

Probe Positioning Mechanisms

The positioning mechanism is employed to anchor the probe in any specific position within the bed precisely. It consists of a 120 cm long stainless steel rod with a diameter of 1.27 cm. The probe is securely mounted on one end of this rod. A shorter rod, 60 cm in length and 1.27 cm in diameter, is perpendicularly and adjustably connected to the longer rod by a Fisher strut connector. The shorter rod is fastened horizontally on top of the 3-D fluidized bed to any desired position.

Air Supply and Humidification System

The air flow for the 2-D and 3-D fluidized beds is supplied by the central compressed air system. Figure 21 shows a schematic diagram of the air supply and humidification system. An oil filter and a dust filter are used to clean the air. The air flow rate is controlled with a gate valve and measured by a rotameter. The pressure of the air is regulated by a pressure regulator and measured by a pressure gauge. The air is moistened by passing it through a humidifier. By controlling the mixing ratio of dry air and moistened air, the optimized air humidity can be reached and maintained. Sticking of the solid particles

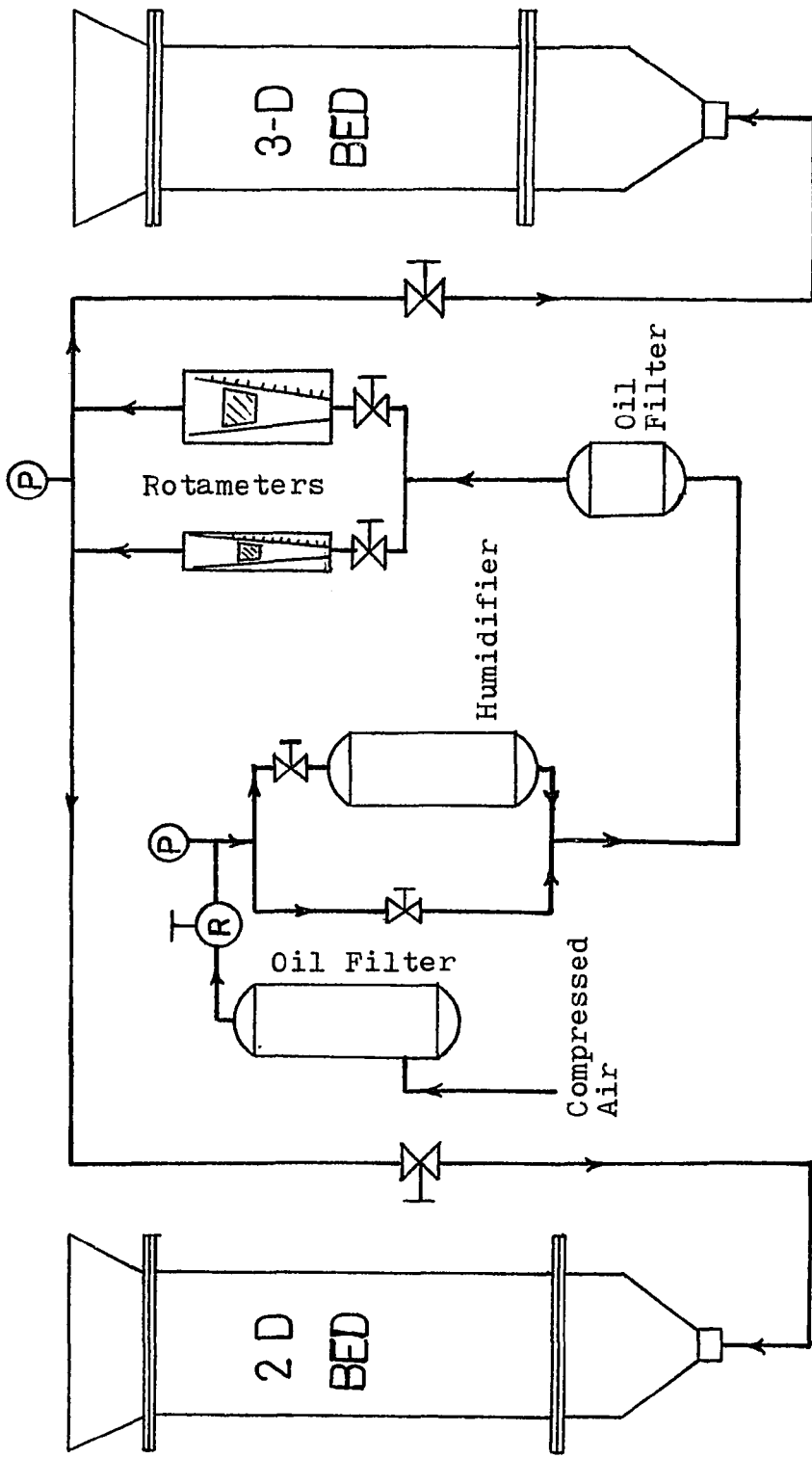

Figure 21. Flow diagram of the air supply and humidification system.

on the wall, due to static electricity, is eliminated by using humidified air. This helps in taking clearer pictures of bubbles by cine camera.

Photographic Equipment and Supplies

The cine camera used is a Kodak model K-100 which is capable of taking pictures up to 64 frames per second. The incident light and the reflected light intensities are measured by a Sekonic model L-398 exposure meter. After combining ASA film sensitivity and shutter speed the exposure meter can directly determine the aperture value. ACME-LITE Model 220 Duolite is used as a photographic light. It is directly on the back of 2-D fluidized bed in order to get a bright bubble image. Kodak Tri-X reversal film 7278 is used in this investigation. The films are analyzed by a L-W 224-ATHENA MKV Photo-Optical Data Analyzer which has automatic frame rates of 1 - 2 - 4 - 6 - 8 - 12 - 18 - 24 frames per seconds, plus stop for still picture viewing and unlimited hold time without loss of light or damage to film.

Power Supply System

A Radio Shack 15 volts DC power supply is used to supply the power which is needed by both LED's and photo-cells. The power needed for operating the Intel 8085

Microprocessor and the timer circuitry are supplied by a Power/Mate Corp. 5 volts regulated DC power supply.

Chapter 4

EXPERIMENTAL PROCEDURES

An experimental run is begun with filling a bed material in either the 2-D or 3-D fluidized bed to the 50 cm level height above the distributor. Before the air is turned on the water level inside the humidifier was checked. The air supply is then turned on, while the dry air and the moistened air flow rates are regulated at the same time to optimize the moisture content in the air.

Qualitative Investigation

The two-dimensional fluidized bed is used for qualitative investigation. While the photographic light is turned on, the light intensity is measured and the aperture value is determined. The camera frame rate is set to be 24 frames per second. The experiment is conducted at different fluidization velocity and with different bed material. The cine photographs are taken during the experiment. The bubble shape, drifting, splitting and coalescence are then analyzed by film observation.

Quantitative Investigation

For quantitatively investigating bubble characteristics

the 3-D fluidized bed is used. This investigation employs the newly developed probing technique which has been discussed in the previous chapter. First of all, the probe is inserted at a certain location within the bed, and the power supplies are then activated to maintain the operation of all the electronic devices. T_1 , T_2 , T_3 , T_{d1} , and T_{d2} are recorded and sent to main frame computer for bubble characteristics calculation. The bubble frequency distribution inside the bed and bubble size distribution at certain locations within the bed can be analyzed statistically. The bubble velocity can also be correlated with the bubble size.

Chapter V

RESULTS AND DISCUSSION

Qualitative Investigation

The general nature of bubbles in gas-fluidized bed are in some respects remarkably like large gas bubbles in a liquid. A typical two-dimensional bubble in a gas-fluidized bed has already been shown in Figure 2. The bubbles are essentially spherical but with an indented base of greater or lesser degrees as seen in Figure 8. This is the idealized or perhaps stable shape of the bubbles.

Large distortions of shape occur as bubbles come closer to one another and to the walls. It is not possible to describe the distortions caused by the walls but the general effect can usually be imagined by analogy with liquid bubbles³³.

The major effect of bubbles coming closer together is to promote coalescence during which considerable distortion can occur. This phenomena is more likely to happen at a higher position. Thus, no consistent pattern and basic shape may be found in the higher region of the fluidized beds. However, for all fluidized systems, basic shapes do exist. The basic shapes observed in the 2-D fluidized bed have been described in Figure 9 through Figure 16.

Based on these eight basic shapes, the shape fitting process has been developed for the probing technique.

The average bubble size increases quite rapidly with height mainly as a result of coalescence. It also increases as a result of overall gas expansion as the pressure decreases with height but this is a small effect except with very dense material or in beds operated at a very low overhead pressure. The coalescence of two originally independent bubbles always occurs in a particular way. Figure 22 shows a cine sequence of the bubbles coalescence phenomenon, a larger bubble overtaking and capturing a smaller one. When the captured bubble moves into the rising drift behind the other, it rises rapidly until it gets into the captor. The previous phenomenon occurs very rapidly and the captured bubble elongates considerably in the final stages. The captor distorts very little but may pause slightly at the moment of mergence.

A simple theory has been proposed concerning the stability of bubbles which predicts that there is a maximum stable bubble size³⁴. When the size of a bubble is larger than the stable bubble size the bubble splits. Figure 23 is a cine sequence showing a bubble splitting. The upper boundary of the bubble develops a downward pointing cusp which grows rapidly into a knife like shape. The cusp tends to originate near the forward stagnation

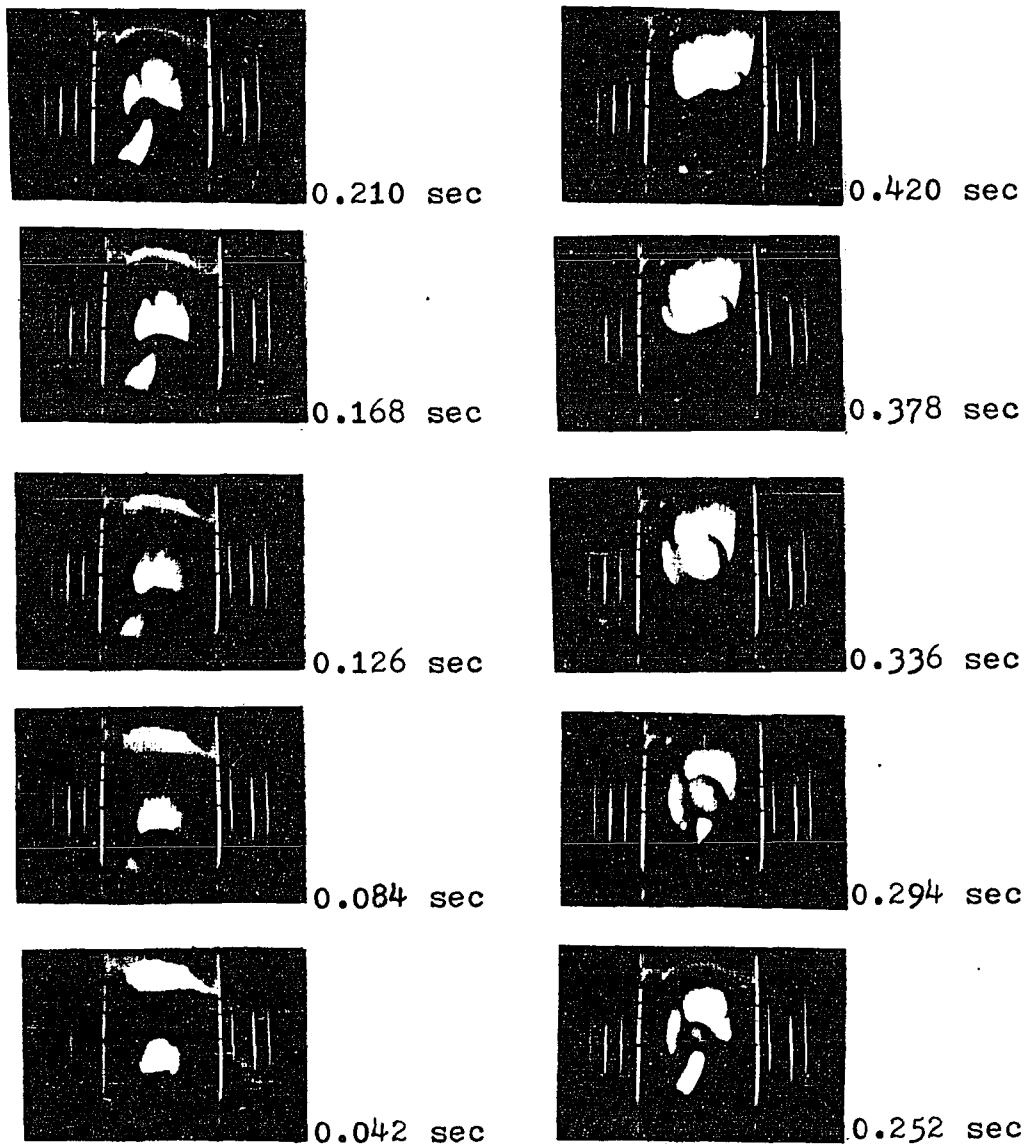

Figure 22. A sequence of bubble coalescence phenomenon.

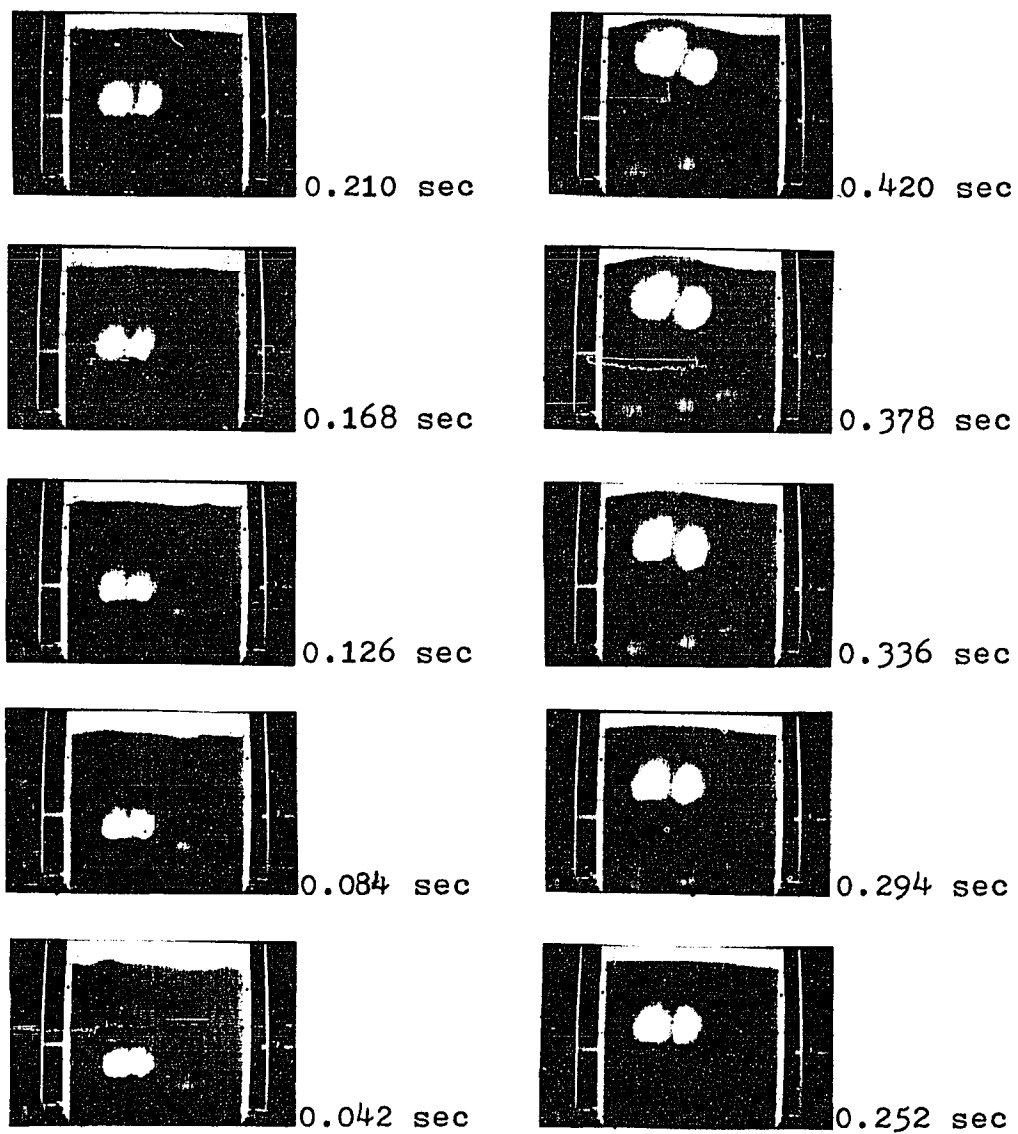

Figure 23. A cine sequence of a bubble splitting.

point and run down to divide the bubble. This vertical splitting is a common phenomenon and few bubble survive long before bifurcating.

Fluidized bed bubbles rise at velocities some tens of centimeters a second and the bigger they are the faster they rise. Velocity also depends on the concentration of bubbles and increases with bed porosity. In other words, the bubble velocity also increases with the gas flow rate.

Quantitative Investigation

Bubble Shapes

The bubble shapes usually are determined by the values of bubble axial length (A_L), frontal surface radius (R_F) and wake surface radius (R_W). Figure 24 shows typical measured bubble shapes. These are very similar to those reported by Rowe and Partridge⁸ for single bubbles using X-ray photography. Some bubbles have a flat bottom shape while others have marked concave indentation of the rear surface. When considerable elongation from the spherical shape occurs, it becomes a paraboloid shape.

Bubble Velocities

The measured bubble velocity in the bed and its variation with their computed bubble equivalent spherical

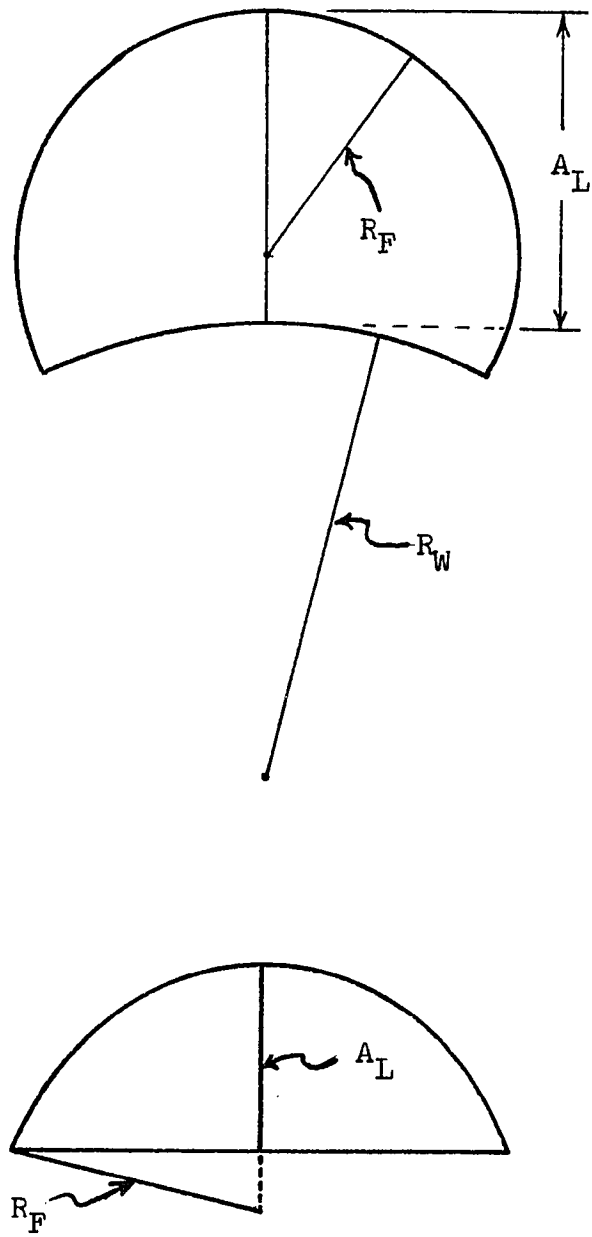

Figure 24. Typical measured bubble shapes.

diameter is shown in Figure 25, where the bubble velocity is calculated from Equation (4). The data represent a sequential sample of about 100 bubbles on the bed centreline and 35 cm above the distributor.

Figures 25 to 27 also indicate the applicability of the Davies-Taylor relationship for spherical cap bubbles³⁵. Clearly, this equation was inadequate to explain the variation in mean bubble velocity with position in the bed. The mean bubble velocity increased with the height above the distributor, and decreased with lateral distance from the centreline, which leads one to suppose that macroscopic bed mixing and circulation are influential. The mean bubble velocity is defined in terms of an average bubble velocity of a group of bubbles within certain bubble size range, while the Z_v and Z_l are defined as the height of the probe above the distributor and the distance between the probe and the bed centreline respectively.

Bubble Size Distribution

A typical bubble size distribution measured by the probe for the fluidized bed is shown in Figure 28, where the characteristic bubble size is the equivalent spherical diameter computed by the shape determination process. These distributions give the bubble number fraction for a particular bubble size at a certain position within the fluidized bed, where the bubble number fraction is

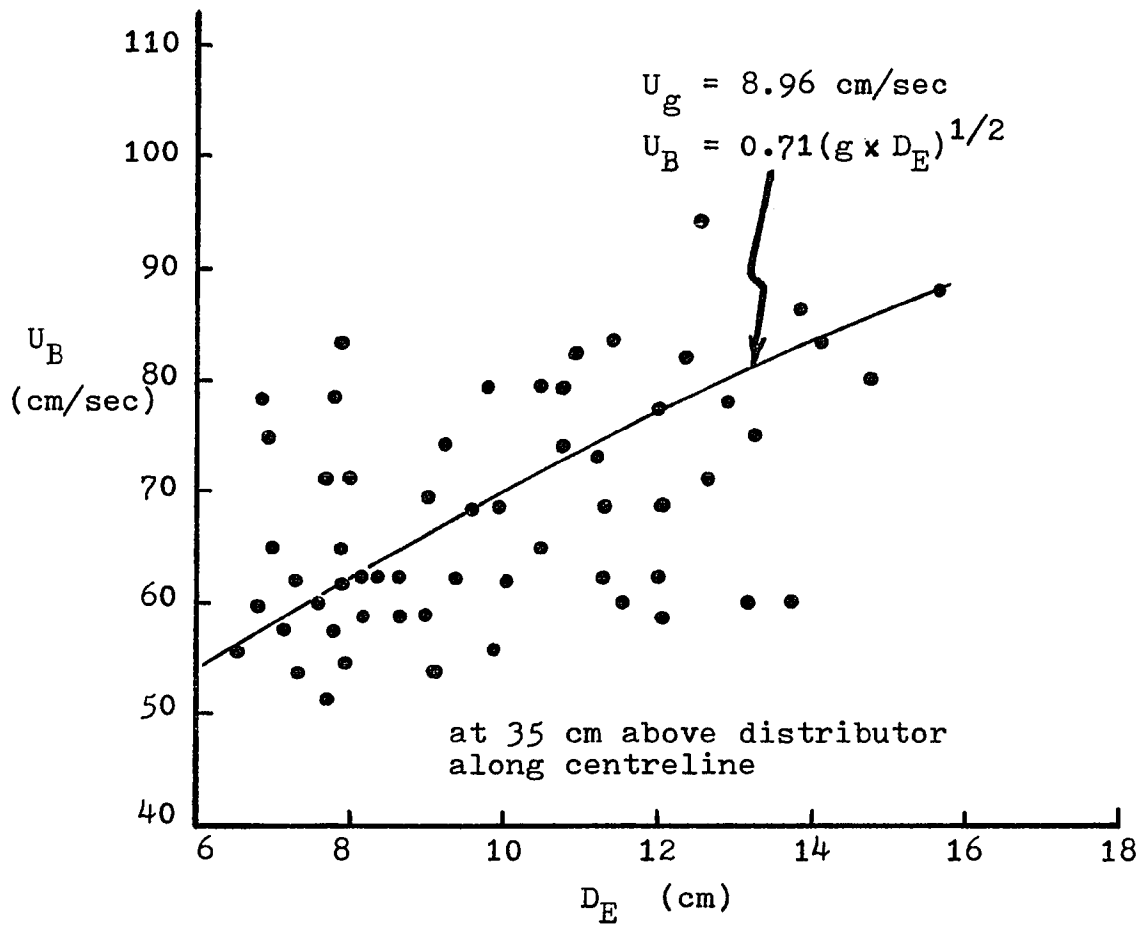

Figure 25. Variation of bubble velocity with equivalent spherical diameter for individual bubbles in the fluidized bed.

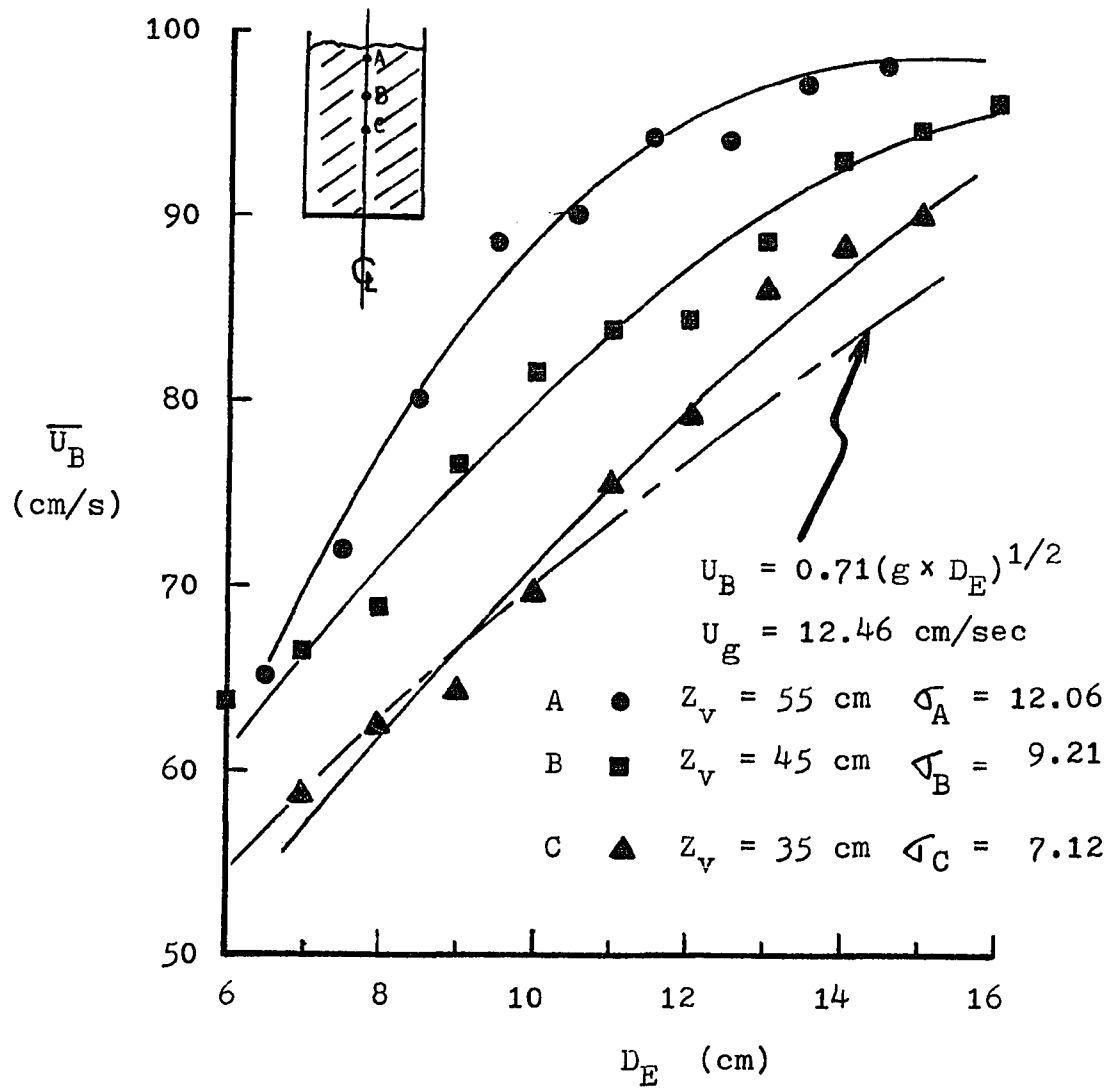

Figure 26. Variation of mean bubble velocity with bubble size and level in the bed on the bed centreline.

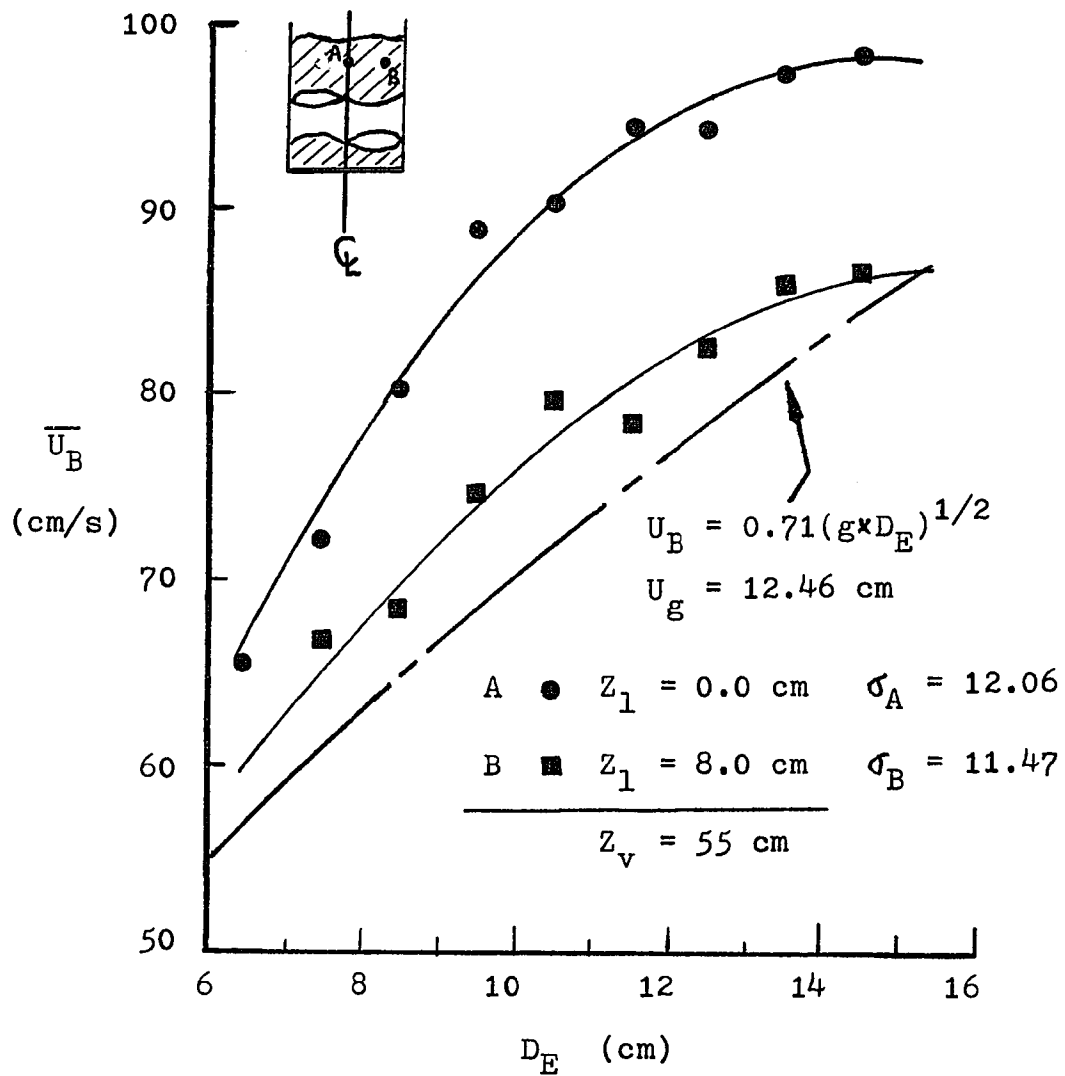

Figure 27. Variation of mean bubble velocity with size and position at the top of the fluidized bed.

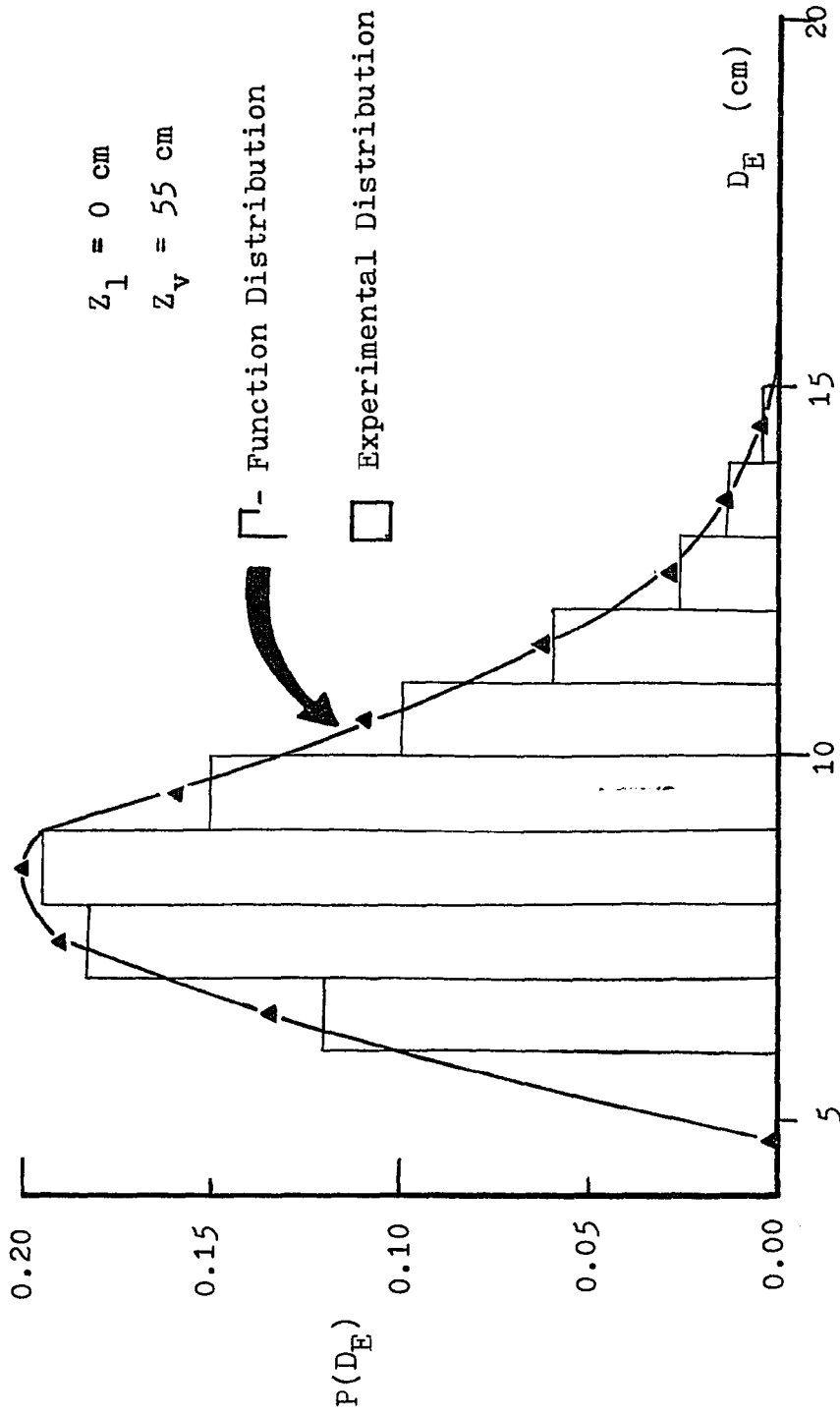

Figure 28. Typical measured bubble size distribution with gamma-function distribution analytical fit.

defined in terms of the number of bubbles for a particular size divided by the total number of measured bubbles. The probe is only capable to detect the bubbles with its traverse axes longer than 6 cm. Thus, the size distribution for bubbles in the bed is naturally truncated. In order to adjust the mean of the truncated bubble size distribution, the truncated error δ is introduced. The truncated gamma function distribution,

$$P(d_e) = \frac{\beta^\alpha}{\Gamma(\alpha)} \text{EXP}(-\beta d_e) \cdot (d_e)^{\alpha-1} \quad (37)$$

where

$$\alpha = \frac{(\bar{d}_e)^2}{\sigma_{d_e}^2} \quad (38)$$

$$\beta = \frac{\bar{d}_e}{\sigma_{d_e}^2} \quad (39)$$

$$d_e = D_E - \delta \quad (40)$$

provides an excellent fit to the data, as shown in Figure 28 and Figure 29.

Figure 30 and Figure 31 show the variation of size distribution with the vertical level above the gas distributor. The bubble size increasing with the level in the

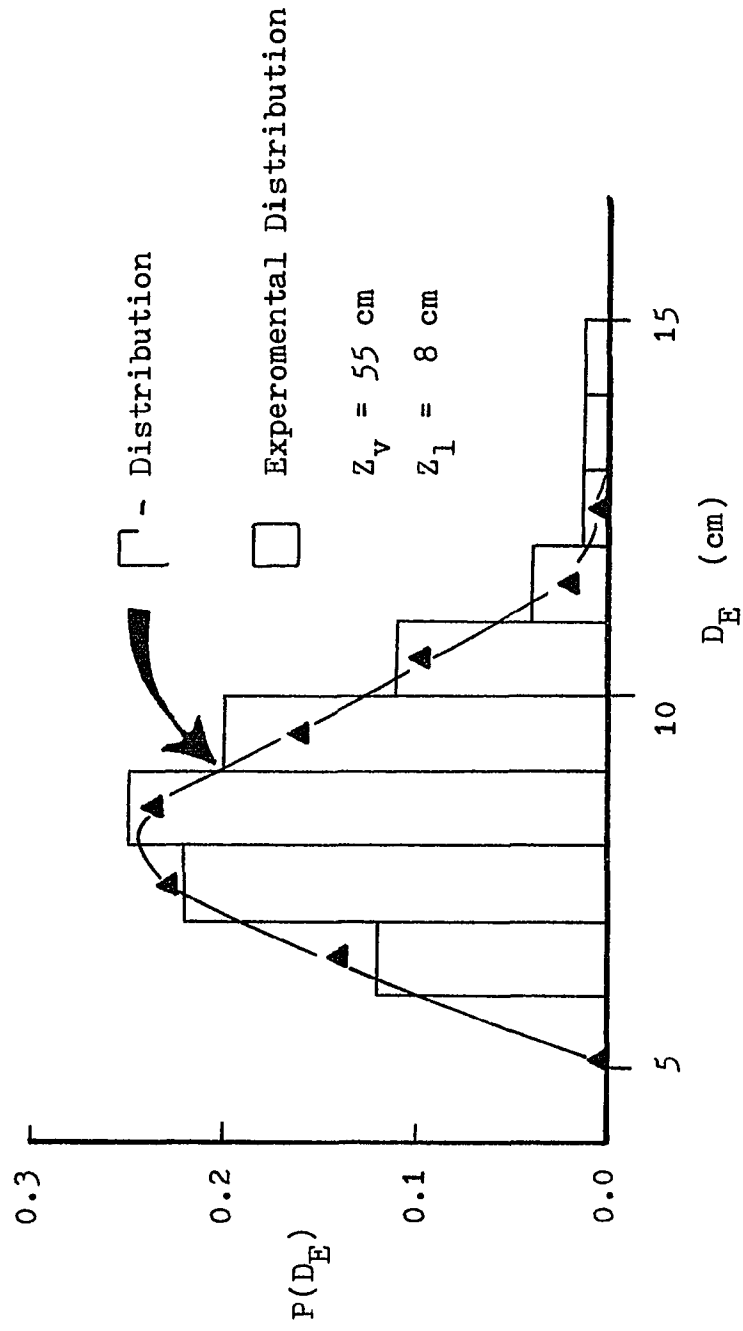

Figure 29. Typical bubble size distribution reported by the probe together with gamma function distribution fit.

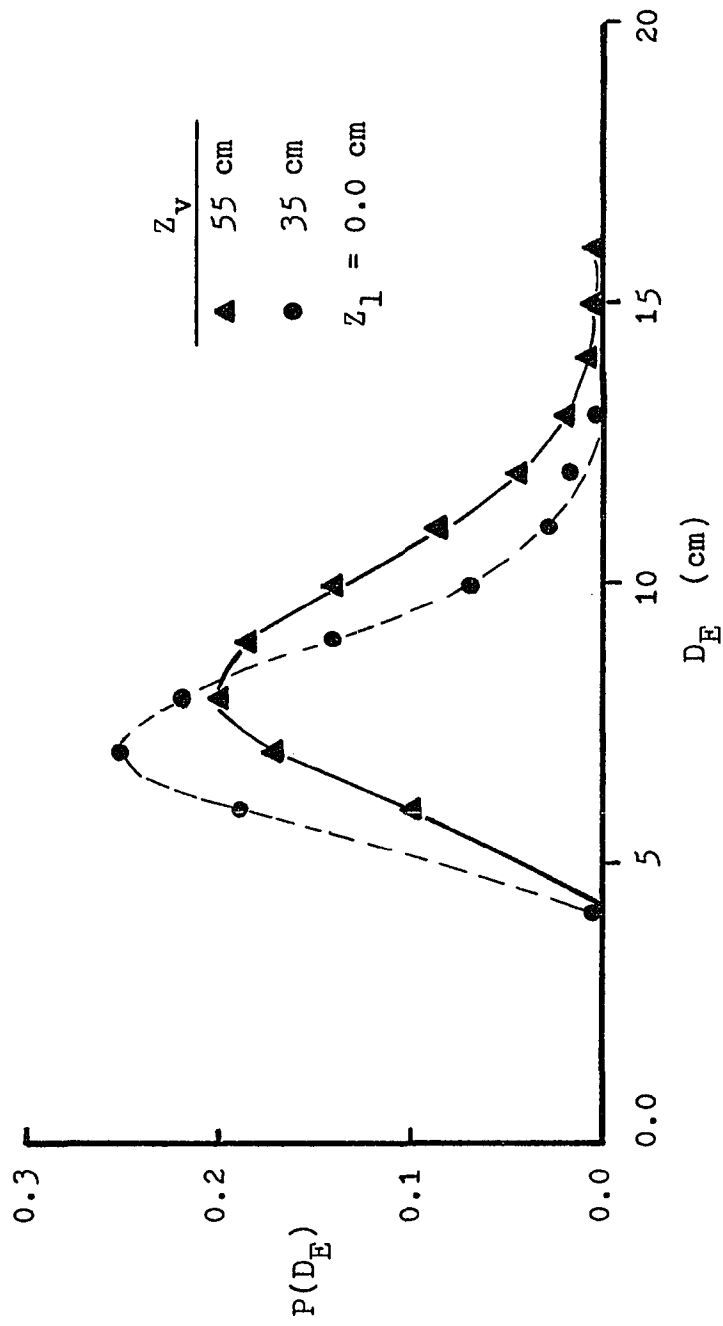

Figure 30. Variation of the gamma function bubble size distribution with vertical level in the fluidized bed on the bed centreline.

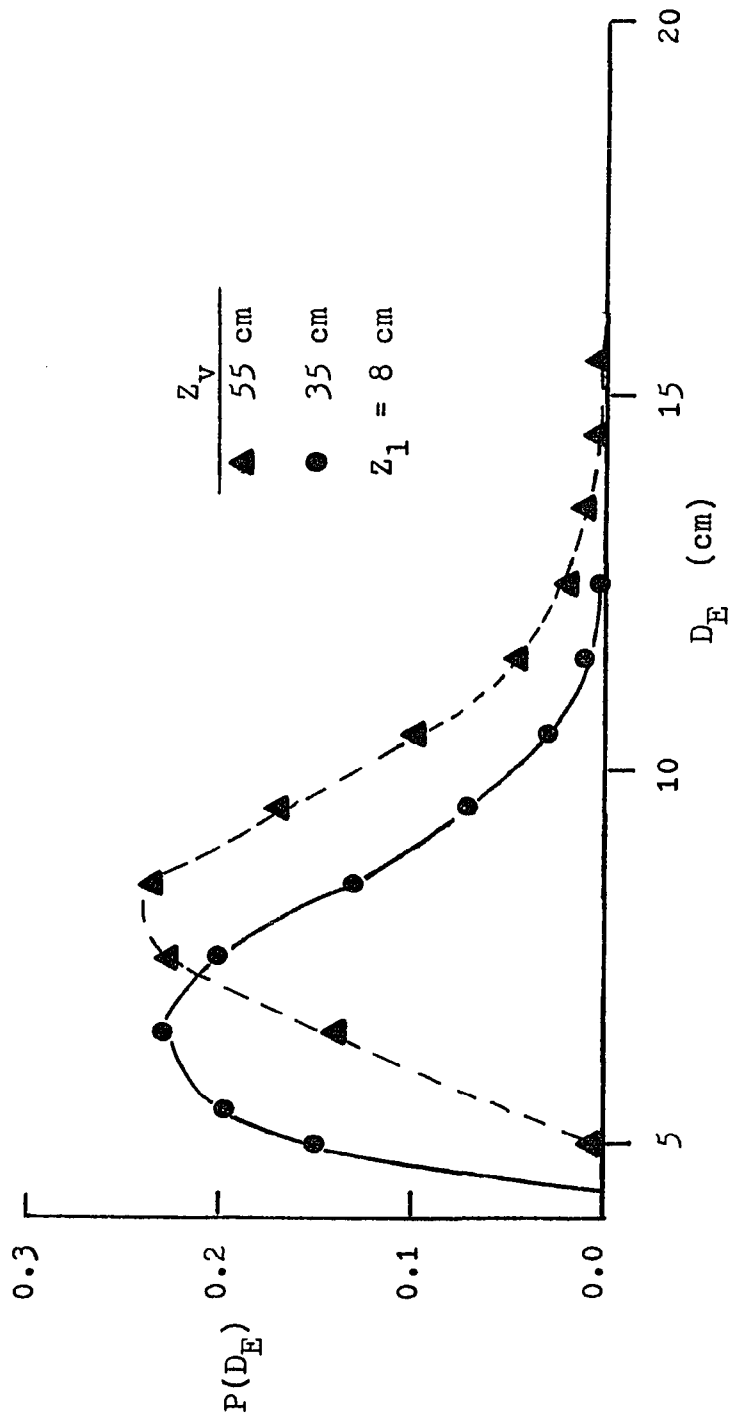

Figure 31. Variation of the gamma function bubble size distribution with vertical level in the fluidized bed at 8 cm distance from bed centreline.

bed is clearly seen. Figure 32 and 33 show the variation of size distribution with lateral position at the top and the middle of the bed respectively.

Figure 34 shows the variation of the mean bubble size distribution in the bed at different positions. The influence of bubble coalescence is obvious.

The changes in the size distribution variance with position in the bed is shown in Figure 35.

Bubble Frequency Distribution

Figure 36 shows the variation of bubble frequency distribution with the position in the bed. The sawtooth type of bubble frequency distribution at the lower part of the bed indicates that the design of the gas distributor plays a major role here. However, the bubbles rise more uniformly at lower level of the bed. The observed non-uniformity and decrement of the bubble development at greater heights is due to the bubble coalescence. The variation of bubble frequency with gas flow rate is shown in Figure 37. These data also show gas bubbles do increase their frequency with gas flow rate as a result of the increment of the formation of bubbles. The result of the different conditions of friction within the fluidized media and between the media and the wall might favor the bubble formation in the zone near the wall.

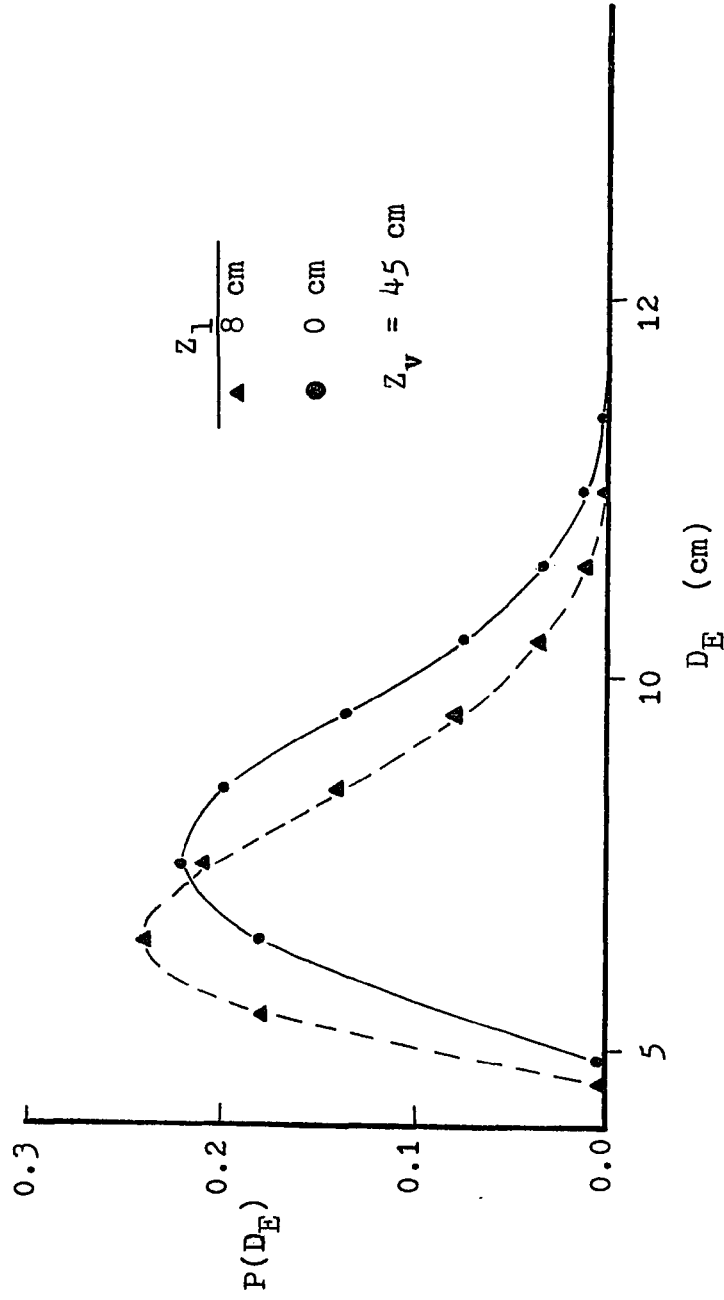

Figure 32. Variation of size distribution with lateral position at the top of the fluidized bed.

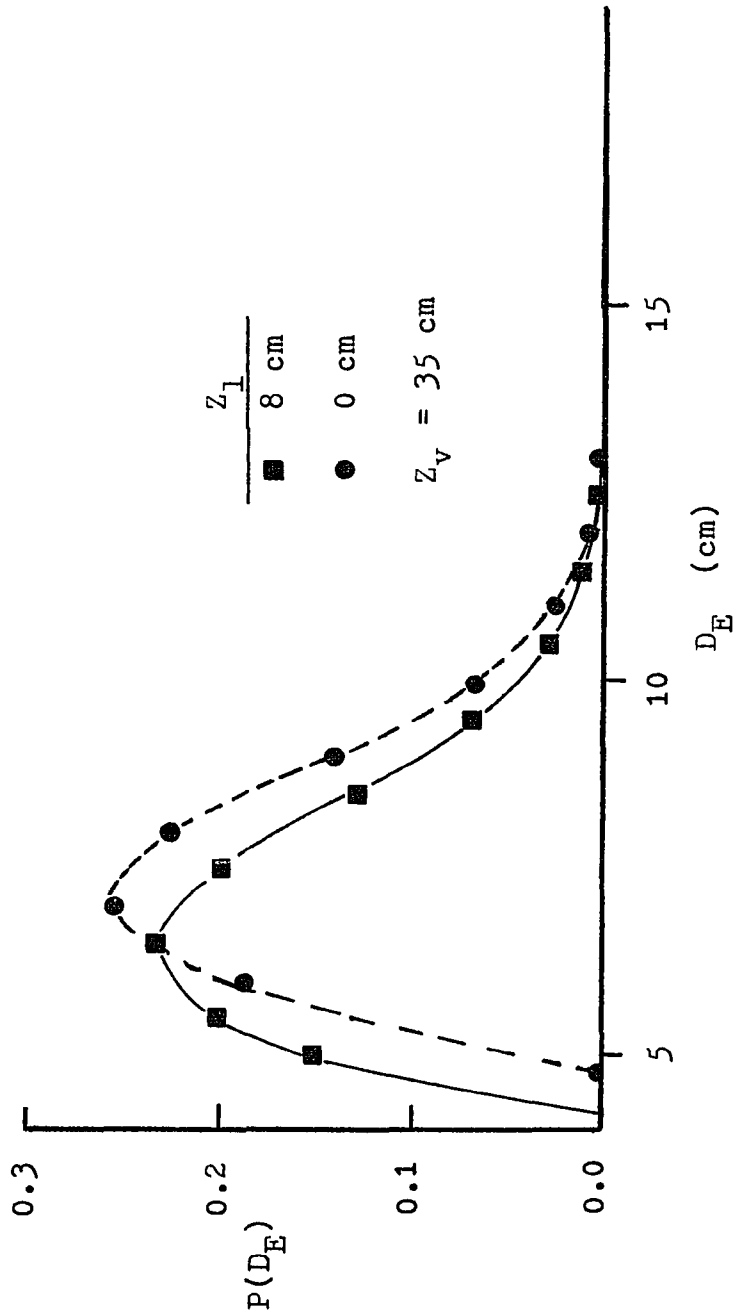

Figure 33. Variation of size distribution with lateral position at the middle of the fluidized bed.

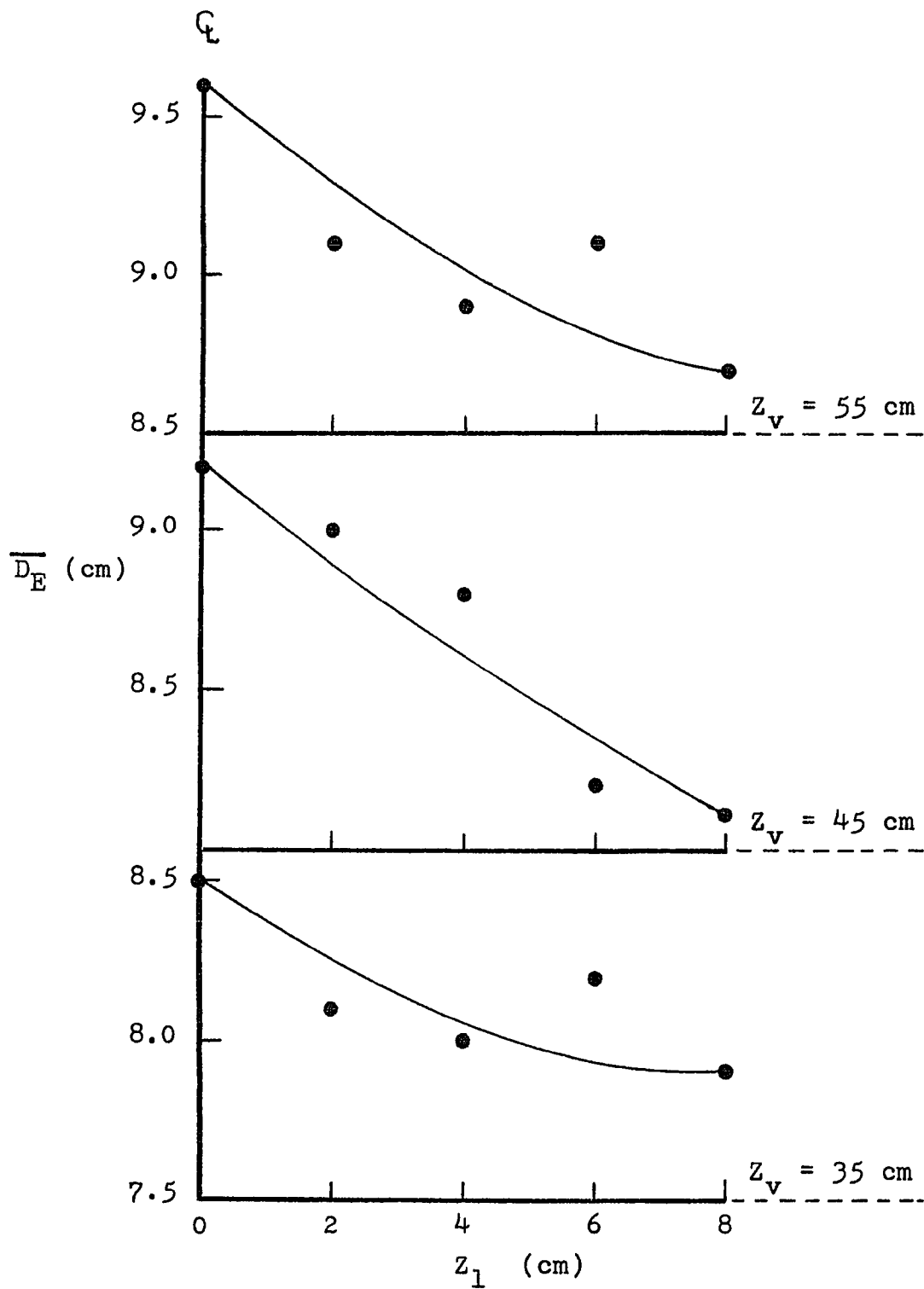

Figure 34. Variation of mean bubble size distribution in the bed at different position.

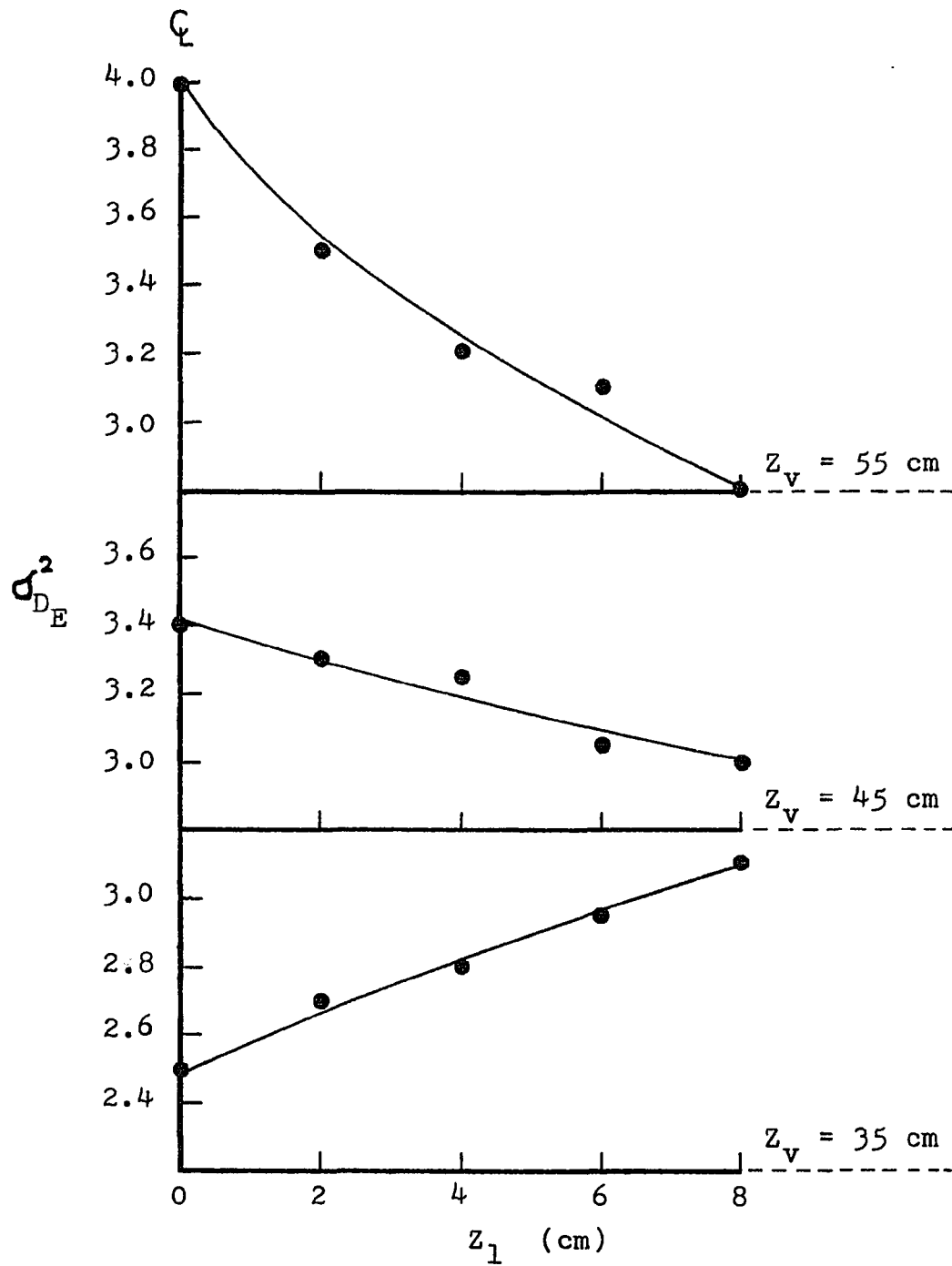

Figure 35. The changes in the size distribution variance with position in the fluidized bed.

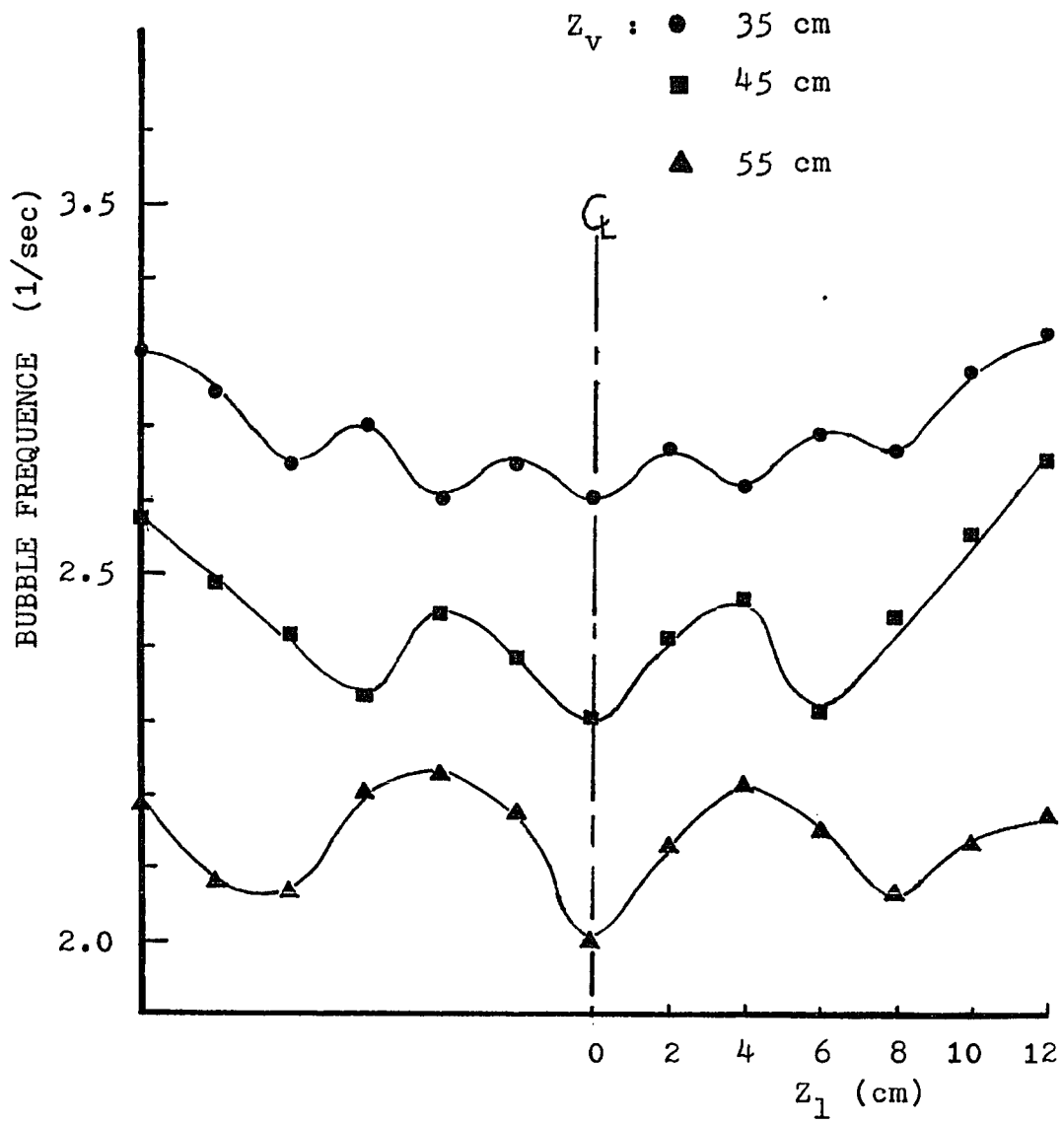

Figure 36. Variation of bubble frequency with position in the fluidized bed.

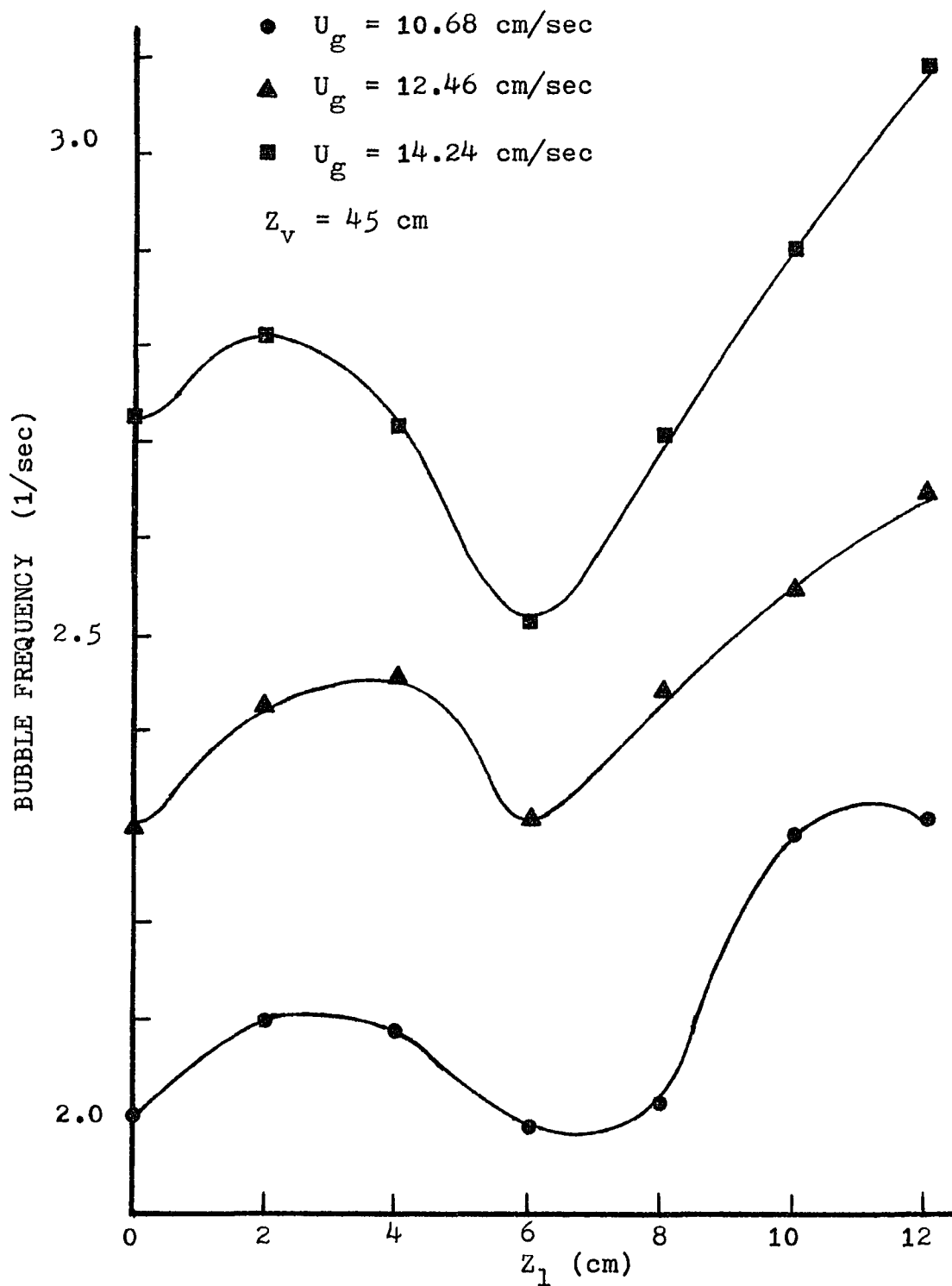

Figure 37. Variation of bubble frequency with superficial gas velocity and lateral position in the fluidized bed.

Chapter VI

CONCLUSIONS

A novel optical probe system has been developed and used for on-line monitoring of bubble characteristics in a three-dimensional gas fluidized bed. The optical probe system which measures the local bubble characteristics and accepts for measurement only those bubbles whose central axes are coincident with the vertical probe axis is capable of resolving fine details of bubble flows in freely bubbling fluidized beds. Four non-inverting comparators with hysteresis has been used to improve the noise immunity of the system. By means of these experiments and application of statistical evaluation methods, the bubble size distribution, shape, and velocity can be determined.

A 96 liter rectangular fluidized bed was used, containing glass beads with a size fraction of 355μ - 250μ . Air was the fluidizing medium with gas velocities ranging from $1.2 U_{mf}$ to $2.0 U_{mf}$. The probe position was varied from 35 cm to 55 cm above the distributor, and 0 to 8 cm from the bed centreline. At moderate gas velocities, the bubble size distribution can be approximated by gamma function distribution. The bubble size distributions vary not only with vertical position

in the fluidized bed but also vary with lateral position in the bed. It was also found that the Davies-Taylor Equation for bubble velocity was inadequate to fit the data, since the velocity varied significantly with position in the bed.

Motion pictures were also taken for a two-dimensional bed to obtain qualitative information on bubble characteristics. In agreement with the limited available results of other authors, this information shows that the basic bubble shapes and bubbles do increase in size with particle size, position height, and gas velocity. The bubble increases its size with the height in the bed by coalescence and maintains a maximum stable size by splitting.

Chapter VII

RECOMMENDATIONS

Further effort should be devoted to study the phenomena of high gas velocity fluidization with fine particles. Thus the continuous operation of a 3-D bed should be set up in order to recycle the particles.

As indicated in the qualitative observation section, the probe would be too large in dimension for small bubble measurement in a fluidized bed with fine particles. Thus, an immediate task would be the further miniaturization of the probe. This may also be necessary for minimizing local disturbance in the bed as pointed out in a recent paper by Rowe and Masson³⁶. Optical fiber would be suggested to replace LED and photo-cell to further reduce the probe dimension.

Also the Intel 8085 microprocessor has the capability of communicating with a teletype. If the interface between Intel 8085 microprocessor and Univac 90/80-4 and a teletype are added, the data processing system will be improved to be a fast real-time data processing system.

REFERENCES

1. Kunii, Daizo and Levenspiel, Octave, Fluidization Engineering, John Wiley, New York, 1968, p. 16.
2. Fitzgerald, Thomas, "Review of Instrumentation for Fluidized Beds", Proceedings of the NSF Workshop on Fluidization and Fluid-Particle Systems/Research Needs and Priorities, Troy, New York, Oct. 1979, p. 291.
3. Wen, C. Y. and Dutta, S., "Research Needs for the Analysis, Design, and Scale-Up of Fluidized Beds", AICHE Symposium, 1977, p. 161, 73, 3.
4. Wace, P. F. and Burnett, S. J., "Flow Patterns in Gas-Fluidized Beds", Institution of Chemical Engineers Transactions, 1961, 39, p. 168.
5. Rowe, P. N. and Stapleton, W. M., "The Behaviour of 12 inch Diameter Gas-Fluidized Beds", Institution of Chemical Engineers Transactions, 1961, 39, p. 181.
6. Rowe, P. N., "The Effect of Bubbles on Gas-Solids Contacting in Fluidized Beds", Chemical Engineering Progress Symposium, 1962, 58, p. 42.
7. Chiba, T. Terashima, K. and Kobayashi, H., "Behaviour of Bubbles in Gas-Solid Fluidized Beds: Initial Formation of Bubbles", Chemical Engineering Science, 1972, 27, p. 965.
8. Rowe, P. N. and Partridge, B. A., "An X-Ray Study of Bubbles in Fluidized Beds", Institution of Chemical Engineers Transactions, 1965, 43, p. T157.
9. Rowe, P. N. and Matsumo, "Single Bubble Injected into a Gas Fluidized Bed and Observed by X-Rays", Chemical Engineering Science, 1971, 26, p. 923.
10. Rowe, P. N., Fluidization, Academic Press, New York, 1971, p. 121.
11. Baumgarten, P. K. and Pigford, R. L., "Density Fluctuations in Fluidized Beds", AICHE Journal, 1960, 6, p. 115.

12. Ocrutt, J. C. and Carpenter, B. H., "Bubble Coalescence and the Simulation of Mass Transport and Chemical Reaction in Gas Fluidized Beds", Chemical Engineering Science, 1971, 26, p. 1049.
13. Park, W. H., Kang, W. K., Capes, C. E. and Osberg, G. L., "The Properties of Bubbles in Fluidized Beds of Conducting Particles as Measured by an Electroresistivity Probe", Chemical Engineering Science, 1969, 24, p. 851.
14. Rigby, G. R., Van Blockland, G. P., Park, W. H., and Capes, C. E., "Properties of Bubbles in Three Phase Fluidized Beds as Measured by an Electroresistivity Probe", Chemical Engineering Science, 1970, 25, p. 1729.
15. Burgess, J. M., and Calderbank, P. H., "The Measurement of Bubble Properties in Two-Phase Dispersions - III", Chemical Engineering Science, 1975, 30, p. 1511.
16. Calderbank, P. H., Periera, J. and Burgess, J. M., Fluidization Technology - Volume I, McGraw Hill, 1976, p. 115.
17. Geldert, D. and Kelsey, J. R., "The Use of Capacitance Probes in Gas Fluidized Beds", Powder Technology, 1972, 6, p. 45.
18. Werther, J. and Molerus, O., "The Local Structure of Gas Fluidized Beds - I. A Statistically Based Measuring System", International Journal of Multiphase Flow, 1973, 1, p. 103.
19. Watkins, S. P. and Creasy, D. E., "The Stability of Bubbles Injected into Particulate Gas-Fluidized Beds", Powder Technology, 1974, 9, p. 241.
20. Otake, T., Tone, S., Kawashima, M. and Shibata, T. J., "Behavior of Rising Bubbles in a Gas-Fluidized Bed at Elevated Temperature", Journal of Chemical Engineering - Japan, 1975, 8, p. 388.
21. Thiel, W. J. and Potter, O. E., "Slugging in Fluidized Beds", Industry and Engineering Chemistry Fundamentals, 1977, 16, p. 242.

22. Ozkaynak, T. F. and Chen, J. C., "Average Residence Time of Emulsion and Void Phases at the Surface of Heat Transfer Tubes in Fluidized Beds", AICHE Symposium, 1978, 174, p. 334.
23. Rooney, N. M. and Harrison, D., Fluidization Technology - Volume II, McGraw Hill, 1976, p. 3.
24. Matson, J. M., "Evidence of Maximum Stable Bubble Size in a Fluidized Bed", AICHE Symposium, 1973, 128, V.69, p. 31.
25. Ormiston, R. M., Mitchell, F. R. G. and Davison, J. F., "The Velocities of Slugs in Fluidized Beds", Institution of Chemical Engineers Transactions, 1965, 43, p. T209.
26. Angelino, H., Charzat, C. and Williams, R., "Evolution de bulles de gaz dans des liquides et des system fluidises", Chemical Engineering Science, 1964, 19, p. 289.
27. Baskakov, A. P., Berg, V. B., Vitt, O. K., Filippovsky, N. F., Kirakosyan, V. A., Goldobin, J. M., and Maskaev, V. K., "Heat Transfer to Objects Immersed in Fluidized Beds", Powder Technology, 1973, 8, p. 273.
28. Cranfield, R. R., "A Probe for Bubble Detection and Measurement in Large Particle Fluidized Beds", Chemical Engineering Science, 1972, 27, p. 239.
29. Yasui, George and Johanson, L. N., "Characteristics of Gas Pockets in Fluidized Beds", AICHE Journal, 1958, 4, p. 446.
30. Winter, Olaf, "Density and Pressure Fluctuation in Gas Fluidized Beds", AICHE Journal, 1968, 14, p. 426.
31. Yoshida, K., Nakajima, K., Hamatini, N. and Shimizu, F., Fluidization, Cambridge University Press, 1978, p. 13.
32. Dutta, S., and Wen, C. Y., "A Simple Probe for Fluidized Bed Measurements", Canadian Journal of Chemical Engineering, 1979, 57, p. 115.

33. Rowe, P. N., Fluidization, Cambridge University Press, New York, 1978, p. 137.
34. Davison, J.F. and Harrison D., Fluidized Particles, Cambridge University Press, New York, 1963.
35. Kunii, Daizo and Levenspiel, Octave, Fluidization Engineering, John Wiley, New York, 1979, p. 101.
36. Rowe, P. N. and Masson, H., "Interaction of Bubbles with Probes in Gas Fluidized Beds", Institution of Chemical Engineers Transactions, 1981, 59, p. 177.

APPENDIX A

COMPUTER AIDED CALCULATION OF
BUBBLE CHARACTERISTICS

```

C THOMAS TAI-PAI CHU
C CHE 790 DOCTORAL RESEARCH AND DISSERTATION
C
C BUBBLE CHARACTERISTICS CALCULATION
C
C PS1:LOWER LIMIT OF PARTICLE SIZE RANGE
C PS2:UPPER LIMIT OF PARTICLE SIZE RANGE
C CT1:NUMBER OF TIME INTERVALS MEASURED
  A   FOR AXIAL LENGTH CALCULATION
C CT2:NUMBER OF TIME INTERVALS MEASURED
C PS1:LOWER LIMIT OF PARTICLE SIZE RANGE
C PS2:UPPER LIMIT OF PARTICLE SIZE RANGE
C CT1:NUMBER OF TIME INTERVALS MEASURED
  A   FOR AXIAL LENGTH CALCULATION
C CT2:NUMBER OF TIME INTERVALS MEASURED
  A   FOR CHORD LENGTH CALCULATION
C CDT1:NUMBER OF TIME INTERVALS MEASURED
  A   FOR VELOCITY CALCULATION
C CDT2:NUMBER OF TIME INTERVALS MEASURED
  A   FOR FRONTAL CURVATURE CALCULATION
C NDB:NUMBER OF DIMENSION OF FLUIDIZED BED
C LP:LATERAL POSITION OF PROBE WITHIN FLUIDIZED BED
C H:VERTICAL POSITION OF PROBE WITHIN FLUIDIZED BED
C FR:SUPERFICIAL GAS VELOCITY
C NDATA:NUMBER OF MEASUREMENTS
C UB:BUBBLE VELOCITY
C AL:BUBBLE VERTICAL AXIAL LENGTH
C B:BUBBLE VERTICAL CHORD LENGTH
C FD:HEIGHT DIFFERENCE BETWEEN TWO POINTS ON
  A   BUBBLE FRONTAL SURFACE DETECTED BY PROBES
C RF:RADIUS OF BUBBLE FRONTAL SURFACE
C DF:DIAMETER OF BUBBLE FRONTAL SURFACE
C WD:HEIGHT DIFFERENCE BETWEEN TWO POINTS ON
  A   BUBBLE WAKE SURFACE DETECTED BY PROBES
C RW:RADIUS OF BUBBLE WAKE SURFACE
C HW:HEIGHT OF BUBBLE WAKE
C RR:RADIUS OF HORIZONTAL BUBBLE CUTTING SURFACE
C VB:BUBBLE VOLUME
C DE:EQUIVALENT BUBBLE DIAMETER
C
  INTEGER PS1,PS2,CT1,CT2,CDT1,CDT2,H
  READ(1,*)NDB,LP,H,FR,PS1,PS2,NDATA
  WRITE(2,101)NDB,LP,H
101  FORMAT(14X,I1,'-D.BED',5X,'PROBE POSITION=(',I2,
  A'CM,',',I2,'CM)')
  WRITE(2,102)FR,PS1,PS2
102  *FORMAT(/,3X,'SUPERFICIAL GAS VELOCITY=',F5.2,
  A'CM/SEC',3X,'PARTICLE SIZE:',I3,'-',I3)
  WRITE(2,103)
103  FORMAT(/,5X,'UB',7X,'AL',6X,'RF',6X,'RR',6X,'RW',

```

```

A5X,'VB',7X,'DE',4X,'SHAPE',/)
DO 19 II=1,NDATA
  READ(1,*)CT1,CT2,CDT1,CDT2
C  T:TIME INTERVAL(SEC)
  T=0.002
  UB=3.0/CDT1/T
  AL=CT1*T*UB
  B=CT2*T*UB
  FD=CDT2*T*UB
C  FD:HEIGHT DIFFERENCE BETWEEN TWO POINTS
  A  ON FRONTAL CURVE DETECTED BY PROBES
C  ...BY TRIAL AND ERROR METHOD TO DETERMINE
  A  THE SUPERFICIAL BUBBLE RADIUS...
C  R1:INITIAL TRIAL VALUE FOR BUBBLE FRONTAL
  A  SURFACE RADIUS
C  DR1:LARGER INCREMENT
C  DR2:SMALL INCREMENT
  R1=((3.0-FD)**2+3*3)**0.5
  DR1=R1*0.1
  DR2=R1*0.01
C  ...USING LARGER INCREMENT TO SEARCH RF...
  DO 1 I=1,30
    RF=R1+DR1*I
    RF1=(RF**2-3*3)**0.5+FD
    X=ABS(RF1-RF)
    IF(X,LE,0.001)GO TO 4
C  ...CHECKING FOR CONVERGENCE...
    IF(RF1.GT,RF)GO TO 2
  1 CONTINUE
  2 RF2=RF-DR1
C  ...USING SMALL INCREMENT TO SEARCH RF...
  DO 3 J=1,10
    RF=RF2+DR2*J
    RF1=(RF**2-3*3)**0.5+FD
    X=ABS(RF1-RF)
    IF(X,LE,0.001)GO TO 4
  3 CONTINUE
  4 DF=RF*2
C  ...BY TRIAL AND ERROR METHOD TO DETERMINE
  A  THE WAKE SURFACE RADIUS.....
C  WD:HEIGHT DIFFERENCE BETWEEN TWO POINTS
  A  ON WAKE SURFACE DETECTED BY PROBES
C  R2:INITIAL TRIAL VALUE FOR WAKE SURFACE
  A  RADIUS DETERMINATION
  WD=ABS(FD+B-AL)
  IF(WD,LE,0.001)GO TO 12
  R2=((3.0-WD)**2+3*3)**0.5
  DR3=R2*0.1
  DR4=R2*0.01
C  ...USING LARGER INCREMENT TO SEARCH RW...

```

```

      DO 5 K=1,30
      RW=R2+DR3*K
      RW1=(RW**2-3*3)**0.5+WD
      Y=ABS(RW1-RW)
      IF(Y.LE.0.001)GO TO 8
C    ...CHECKING FOR CONVERGENCE...
      IF(RW1.GT.RW)GO TO 6
5     CONTINUE
6     RW2=RW-DR3
C    ...USING SMALL INCREMENT TO SEARCH RW...
      DO 7 L=1,10
      RW=RW2+DR4*L
      RW1=(RW**2-3*3)**0.5+WD
      Y=ABS(RW1-RW)
      IF(Y.LE.0.001)GO TO 8
7     CONTINUE
8     IF(AL.GE.DF)GO TO 16
      RB=RF
C    DB: SUPERFICIAL BUBBLE DIAMETER
      DB=DF
      IF(AL-RB)9,10,11
C    ...IF BUBBLE AXIAL LENGTH IS LESS THAN
A    THE SUPERFICIAL BUBBLE RADIUS.....
C    HW: HEIGHT OF BUBBLE WAKE
C    SS: HEIGHT OF BUBBLE
9     HW=(2*RB*AL-AL**2)/2/(RW-RB+AL)
      RR=(2*RW*HW-HW**2)**0.5
      SS=AL+HW
C    ...IF BUBBLE HEIGHT LESS THAN BUBBLE RADIUS
A    AND WITH DENTED BOTTOM.....
      IF(SS.GT.RB)GO TO 10
      VB1=3.1416*(AL+HW)*(3*RR**2+(AL+HW)**2)/6
      VB2=3.1416*HW*(3*RR**2+HW**2)/6
      VB=VB1-VB2
      DE=(6*VB/3.1416)**(1./3)
      WRITE(2,105)UB,AL,RF,RR,RW,VB,DE
105    FORMAT(1X,5F8.2,F8.1,F8.2,3X,'S.L.D.')
```

```

      GO TO 19
C    ...IF BUBBLE HEIGHT EQUALS TO BUBBLE RADIUS
A    AND AXIAL LENGTH LESS THAN BUBBLE RADIUS....
10    V1=3.1416*DB**3/6
      V2=3.1416*HW*(3*RR**2+HW**2)/6
      VB=V1-V2
      DE=(6*VB/3.1416)**(1./3)
      WRITE(2,106)UB,AL,RF,RR,RW,VB,DE
106    FORMAT(1X,5F8.2,F8.1,F8.2,3X,'H.S.D.')
```

```

      GO TO 19
C    ...IF BOTH BUBBLE HEIGHT AND AXIAL
A    LENGTH ARE GREATER THAN BUBBLE RADIUS....
11    V1=3.1416*(DB**3)/6
```

```

S=(RB+RW+(AL-RB+RW))/2
F=((S-RB)*(S-RW)*(S-AL+RB-RW)/S)**0.5
A1=ATAN(F/(S-RW))*2
RR=RB*SIN(A1)
H1=RB*COS(A1)-AL+RB
V2=3.1416*H1*(3*RR*RR+H1**2)/6
H2=RB*(1-COS(A1))
V3=3.1416*H2*(3*RR*RR+H2**2)/6
VB=V1-V2-V3
DE=(6*VB/3.1416)**(1./3)
WRITE(2,107)UB,AL,RF,RR,RW,VB,DE
107 FORMAT(1X,5F8.2,F8.1,F8.2,3X,'S.G.D.')
GO TO 19
C ...FOR FLAT BOTTOM BUBBLE AND AXIAL LENGTH
A EQUALS TO BUBBLE HEIGHT.....
12 IF(AL.GE.DF)GO TO 17
DB=DF
RB=RF
C ...FOR BUBBLE HEIGHT LESS THAN SUPERFICIAL
A BUBBLE RADIUS.....
IF(AL-RB)13,14,15
13 RR=(RB**2-(RB-AL)**2)**0.5
VB=3.1416*AL*(3*RR**2+AL**2)/6
DE=(6*VB/3.1416)**(1./3)
WRITE(2,108)UB,AL,RF,RR,VB,DE
108 FORMAT(1X,4F8.2,5X,'---',1X,F8.1,F8.2,3X,'S.L.')
GO TO 19
C ...IF BUBBLE HEIGHT EQUALS TO SUPERFICIAL
A BUBBLE RADIUS.....
14 RR=RF
VB=3.1416*DB**3/12
DE=(6*VB/3.1416)**(1./3)
WRITE(2,109)UB,AL,RF,RR,VB,DE
109 FORMAT(1X,4F8.2,5X,'---',1X,F8.1,F8.2,3X,'H.S.')
GO TO 19
C ...IF BUBBLE HEIGHT IS GREATER THAN
A THE SUPERFICIAL BUBBLE RADIUS.....
15 RR=(RB**2-(AL-RB)**2)**0.5
VB1=3.1416*DB**3/6
VB2=3.1416*(DB-AL)*(3*RR**2+(DB-AL)**2)/6
VB=VB1-VB2
DE=(6*VB/3.1416)**(1./3)
WRITE(2,110)UB,AL,RF,RR,VB,DE
110 FORMAT(1X,4F8.2,5X,'---',1X,F8.1,F8.2,3X,'S.G.')
GO TO 19
C ...FOR PARABOLIC BUBBLE...
C ...PARABOLIC BUBBLE WITH DENTED WAKE...
16 C=3*3/FO
C1=(C-2*RW)**2-4*C*AL
IF(C1.LT.0.0)GO TO 18

```

```

HW=(RW*2-C-((C-RW*2)**2-4*C*AL)**0.5)/2
RR=(C*(AL+HW)**0.5
V4=3.1416*HW*(3*RR*RR+HW**2)/6
V5=C*3.1416*(AL+HW)**2/2
VB=V5-V4
DE=(6*VB/3.1416)**(1./3)
WRITE(2,111)UB,AL,RF,RR,RW,VB,DE
111 FORMAT(1X,5F8.2,F8.1,F8.2,3X,'P.C.')
```

GO TO 19

```

C ...PARABOLIC BUBBLE WITH FLAT BOTTOM...
17 C=3*3/FO
RR=(C*AL)**0.5
VB=C*3.1416*AL**2/2
DE=(6*VB/3.1416)**(1./3)
WRITE(2,112)UB,AL,RF,RR,VB,DE
112 FORMAT(1X,4F8.2,5X,'--',1X,F8.1,F8.2,3X,'PAR.')
```

GO TO 19

```

C ...PARABOLIC BUBBLE WITH A PARTIAL DENTED WAKE...
18 RR=(RW+3.)/2
HW=RW-(RW**2-RR**2)**0.5
V6=3.1416*HW*(3*RR*RR+HW**2)/6
V7=3.1416*C*(AL+HW)**2/2
VB=V7-V6
DE=(6*VB/3.1416)**(1./3)
WRITE(2,113)UB,AL,RF,RR,RW,VB,DE
113 FORMAT(1X,5F8.2,F8.1,F8.2,3X,'P.C.')
```

19 CONTINUE

```

STOP
END
```

APPENDIX B

SOFTWARE SIGNAL DISCRIMINATOR AND PROCESSOR

FILE: FLUID:GCJ

HEWLETT-PACKARD: 8085 Assembler

LOCATION	OBJECT	CODE	LINE	SOURCE	LINE
			1	"8085"	
			2		
	<2000>		3	EPSILLON	EQU 2000H
	<2001>		4	DISPCNT	EQU 2001H
	<2002>		5	DATA	EQU 2002H
	<2004>		6	FREQDAT	EQU 2004H
	<20CF>		7	INTER	EQU 20CFH
	<9800>		8	RAM	EQU 9800H
	<A003>		9	STA1	EQU 0A003H
	<A803>		10	STA2	EQU 0A803H
	<B003>		11	STA3	EQU 0B003H
	<B803>		12	STA4	EQU 0B803H
	<A000>		13	VEL	EQU 0A000H
	<A001>		14	DIA	EQU 0A001H
	<A002>		15	PRB1	EQU 0A002H
	<A800>		16	PRB3	EQU 0A800H
	<A801>		17	OFFSET	EQU 0A801H
	<A802>		18	CURVE	EQU 0A802H
	<B000>		19	FREQCNT	EQU 0B000H
	<B800>		20	TIMER1	EQU 0B800H
	<B802>		21	CLOCK	EQU 0B802H
			22		
0000	AF		23	XRA A	;SET A TO 0
			24		
0001	21A003		25	LXI H,STA1	;PROG TIMER#1
0004	3E11		26	MVI A,11H	
0006	77		27	MOV M,A	
0007	3E71		28	MVI A,71H	;DOUBLE BYTE
0009	77		29	MOV M,A	
000A	3EB1		30	MVI A,0B1H	;DOUBLE BYTE
000C	77		31	MOV M,A	
			32		
000D	21A803		33	LXI H,STA2	;PROG TIMER#2
0010	3E31		34	MVI A,31H	;DOUBLE BYTE
0012	77		35	MOV M,A	
0013	3E51		36	MVI A,51H	
0015	77		37	MOV M,A	
0016	3E91		38	MVI A,91H	
0018	77		39	MOV M,A	
			40		
0019	21B003		41	LXI H,STA3	;PROG FREQ CNTR
001C	3E31		42	MVI A,31H	;DOUBLE BYTE
001E	77		43	MOV M,A	
001F	3E71		44	MVI A,71H	;DOUBLE BYTE
0021	77		45	MOV M,A	
0022	3EB1		46	MVI A,0B1H	;DOUBLE BYTE
0024	77		47	MOV M,A	

		48			
0025	21B803	49		LXI H,STA4	;PROG TIMERS
0028	3E37	50		MVI A,37H	;DOUBLE BYTE
002A	77	51		MOV M,A	
002B	3E77	52		MVI A,77H	;DOUBLE BYTE
002D	77	53		MOV M,A	
002E	3EB1	54		MVI A,0B1H	;DOUBLE BYTE
0030	77	55		MOV M,A	
		56			
0031	21B800	57		LXI H,TIMER1	;PROG CLK TIMER
0034	113072	58		LXI D,3072H	;2 MSEC. CLK
0037	73	59		MOV M,E	
0038	72	60		MOV M,D	
0039	23	61		INX H	
003A	110500	62		LXI D,500H	;1 SEC. CLK
003D	73	63		MOV M,E	
003E	72	64		MOV M,D	
		65			
003F	219800	66		LXI H,RAM	;CLR MEMORY
0042	AF	67		XRA A	;SET A TO 0
0043	2D	68	ERASE	DCR L	
0044	77	69		MOV M,A	
0045	C20043	70		JNZ ERASE	
		71			
0048	222002	72		SHLD DATA	;LD DATA VECT
004B	AF	73		XRA A	;SET A TO 0
004C	322001	74		STA DISPCNT	
		75			
004F	3EC3	76		MVI A,0C3H	;LD INTR VECT
0051	3220CE	77		STA 20CEH	
0054	210064	78		LXI H,START	
0057	2220CF	79		SHLD INTER	
		80			
005A	3120C2	81		LXI SP,20C2H	;SET STK PNTR
		82			
005D	3E1B	83		MVI A,1BH	;DIS 5.5 & 6.5
005F	30	84		SIM	
0060	FB	85		EI	
		86			
0061	C30061	87	WAIT	JMP WAIT	
		88			
0064	AF	89	START	XRA A	;SET A TO 0
0065	CD036E	90		CALL 36EH	;DISP '00'
		91			
0068	11FFFF	92		LXI D,0FFFFH	;DELAY FOR INTR
006B	CD05F1	93		CALL 5F1H	
		94			
006E	3E99	95		MVI A,99H	;RES FREQ CNTRS
0070	21B000	96		LXI H,FREQCNT	
0073	77	97		MOV M,A	

0074	77	98		MOV M,A	
0075	23	99		INX H	
0076	77	100		MOV M,A	
0077	77	101		MOV M,A	
0078	23	102		INX H	
0079	77	103		MOV M,A	
007A	77	104		MOV M,A	
		105			
007B	21B802	106		LXI H,CLOCK	;RES SEC CLK
007E	77	107		MOV M,A	
007F	77	108		MOV M,A	
		109			
0080	210145	110		LXI H,EXIT	;SET INTR VECT
0083	2220CF	111		SHLD INTER	
		112			
0086	3E1B	113		MVI A,1BH	;DIS 5.5 & 6.5
0088	30	114		SIM	
0089	FB	115		EI	
		116			
008A	3E99	117	RESTART	MVI A,99H	;RES TIMER #1
008C	21A000	118		LXI H,VEL	
008F	77	119		MOV M,A	
0090	23	120		INX H	
0091	77	121		MOV M,A	
0092	77	122		MOV M,A	
0093	23	123		INX H	
0094	77	124		MOV M,A	
0095	77	125		MOV M,A	
		126			
0096	21A800	127		LXI H,PRB3	;RES TIMER#2
0099	77	128		MOV M,A	
009A	77	129		MOV M,A	
009B	23	130		INX H	
009C	77	131		MOV M,A	
009D	23	132		INX H	
009E	77	133		MOV M,A	
		134			
009F	21008A	135		LXI H,RESTART	;LD RESTART PNTR
		136			
00A2	DB00	137	CHK1	IN 00H	;CHK FOR 4
00A4	E60F	138		ANI 0FH	
00A6	FE00	139		CPI 00H	
00A8	CA00A2	140		JZ CHK1	
00AB	FE01	141		CPI 01	
00AD	CA00B1	142		JZ CHK2	
00B0	E9	143		PCHL	
		144			
00B1	DB00	145	CHK2	IN 00H	;CHK FOR 4 & 2
00B3	E60F	146		ANI 0FH	
00B5	FE01	147		CPI 01H	
00B7	CA00B1	148		JZ CHK2	
00BA	FE03	149		CPI 03H	
00BC	CA00C0	150		JZ CHK3	

00BF E9	151	PCHL	
	152		
00C0 DB00	153	CHK3	IN 00H ;CHK FOR ALL
00C2 E60F	154		ANI 0FH
00C4 FE0F	155		CPI 0FH
00C6 CA00D1	156		JZ CHK4
00C9 E603	157		ANI 03H
00CB FE03	158		CPI 03H
00CD CA00C0	159		JZ CHK3
00D0 E9	160		PCHL
	161		
00D1 DB00	162	CHK4	IN 00H ;CHK FOR 1,2 & 3
00D3 E60F	163		ANI 0FH
00D5 FE0F	164		CPI 0FH
00D7 CA00D1	165		JZ CHK4
00DA FE0E	166		CPI 0EH
00DC CA00E0	167		JZ CHK5
00DF E9	168		PCHL
	169		
00E0 DB00	170	CHK5	IN 00H ;CHK FOR 1,2,3
00E2 E60F	171		ANI 0FH ;OR NONE.
00E4 FE00	172		CPI 00H
00E6 CA00EF	173		JZ OK
00E9 E601	174		ANI 01H
00EB CA00E0	175		JZ CHK5
00EE E9	176		PCHL
	177		
00EF 21A001	178	OK	LXI H,DIA ;LOAD DIA
00F2 4E	179		MOV C,M
00F3 46	180		MOV B,M
	181		
00F4 21A002	182		LXI H,PRB1 ;COMP WITH #1
00F7 7E	183		MOV A,M
00F8 91	184		SUB C
00F9 7E	185		MOV A,M
00FA 98	186		SBB B
00FB DA008A	187		JC RESTART
	188		
00FE 21A800	189		LXI H,PRB3 ;COMP WITH #3
0101 7E	190		MOV A,M
0102 91	191		SUB C
0103 7E	192		MOV A,M
0104 98	193		SBB B
0105 DA008A	194		JC RESTART
	195		
0108 CD0174	196		CALL BCD ;CALC MAX OFFSET
010B CD015B	197		CALL MULT
010E 3AA801	198		LDA OFFSET ;COMP W/ OFFSET
0111 5F	199		MOV E,A
0112 3E99	200		MVI A,99H
0114 93	201		SUB E
0115 BC	202		CMP H ;CY=1 IF A<H
0116 D2008A	203		JNC RESTART
	204		
0119 2A2002	205		LHLD DATA ;LD DATA ADDR

011C	CD017D	206		CALL STORE1	;STORE DIA
		207			
011F	EB	208		XCHG	;DE<DATA
0120	21A800	209		LXI H,PRB3	;LOAD #3
0123	CD0182	210		CALL STORE2	
0126	EB	211		XCHG	;HL<DATA
		212			
0127	3AA000	213		LDA VEL	;LOAD VEL
012A	47	214		MOV B,A	
012B	3AA802	215		LDA CURVE	;LOAD CURVE
012E	4F	216		MOV C,A	
012F	CD0174	217		CALL BCD	
0132	CD017D	218		CALL STORE1	;SAVE BOTH
		219			
0135	222002	220		SHLD DATA	;SAVE DATA PTR
		221			
0138	3A2001	222		LDA DISPCNT	;DISP DATA CNT
013B	3C	223		INR A	
013C	322001	224		STA DISPCNT	
013F	CD036E	225		CALL 36EH	
		226			
0142	C3008A	227		JMP RESTART	
		228			
0145	21B000	229	EXIT	LXI H,FREQCNT	;SAVE FREQ
0148	112004	230		LXI D,FREQDAT	;IN 2004.
014B	CD0182	231		CALL STORE2	
014E	CD0182	232		CALL STORE2	
0151	CD0182	233		CALL STORE2	
		234			
0154	21B802	235		LXI H,CLOCK	;SAVE TIME
0157	CD0182	236		CALL STORE2	;IN 200A.
		237			
015A	CF	238		RST 1	;WARM START
		239			
015B	3A2000	240	MULT	LDA EPSILLON	;INIT A,E,H&L
015E	5F	241		MOV E,A	;BC X .E = H.L
015F	210000	242		LXI H,00H	
0162	AF	243		XRA A	
		244			
0163	7D	245	MULTO	MOV A,L	;ADD LOW BYTE
0164	81	246		ADD C	
0165	27	247		DAA	
0166	6F	248		MOV L,A	
		249			
0167	7C	250		MOV A,H	;ADD HIGH BYTE
0168	88	251		ADC B	
0169	27	252		DAA	
016A	67	253		MOV H,A	
		254			

016B	3E99	255	MVI A,99H	;A=E-1
016D	83	256	ADD E	
016E	27	257	DAA	
016F	5F	258	MOV E,A	
		259		
0170	C20163	260	JNZ MULT0	;CHK IF DONE
0173	C9	261	RET	
		262		
		263		
0174	3E99	264	MVI A,99H	;MAKE CNTR
0176	90	265	SUB B	;VALUES BCD.
0177	47	266	MOV B,A	
0178	3E99	267	MVI A,99H	
017A	91	268	SUB C	
017B	4F	269	MOV C,A	
017C	C9	270	RET	
		271		
017D	70	272	MOV M,B	
017E	23	273	INX H	
017F	71	274	MOV M,C	
0180	23	275	INX H	
0181	C9	276	RET	
		277		
0182	4E	278	MOV C,M	;GET DATA
0183	46	279	MOV B,M	;FROM CNTR
0184	CD0174	280	CALL BCD	
0187	EB	281	XCHG	;HL<DATA
0188	70	282	MOV M,B	;PUT DATA
0189	23	283	INX H	;IN MEMORY
018A	71	284	MOV M,C	
018B	23	285	INX H	
018C	EB	286	XCHG	;DE<DATA
018D	23	287	INX H	
018E	C9	288	RET	

Errors= 0

Appendix C

DESCRIPTION OF CALIBRATION PROCEDURE
FOR COMPARATOR CIRCUIT

The circuit shown in Figure 38 is a non-inverting comparator with hysteresis. The actual outputs from a signal amplifier circuit and a comparator without hysteresis are shown in Figure 38A and Figure 38B respectively. Clearly, the amplifier has failed to accurately determine the timing of bubbles reaching and leaving the probe, and the comparator without hysteresis has failed to prevent the oscillation caused by the raining inside the bubbles. Only the non-inverting comparator with hysteresis can preprocess the four probe sensor signals to make it well defined and digital compatible for use by an Intel 8085 data-logger. An actual recorder output from this comparator circuit is given in Figure 39.

The sensor signal is a function of both the LED/photo-cell sensor and the density of the bed at the sensor sight, it is therefore necessary to tune each of the four comparator circuits to its associated sensor. Two set points are used to determine the output of the comparator. The first point (V_{H1}) is set near the upper limit of the sensor signal range. This set point is used to set the comparator output (V_0) at 5 volts for

$$V_i \left(\frac{R_f}{R_i + R_f} \right) > V_{ref} \quad (41)$$

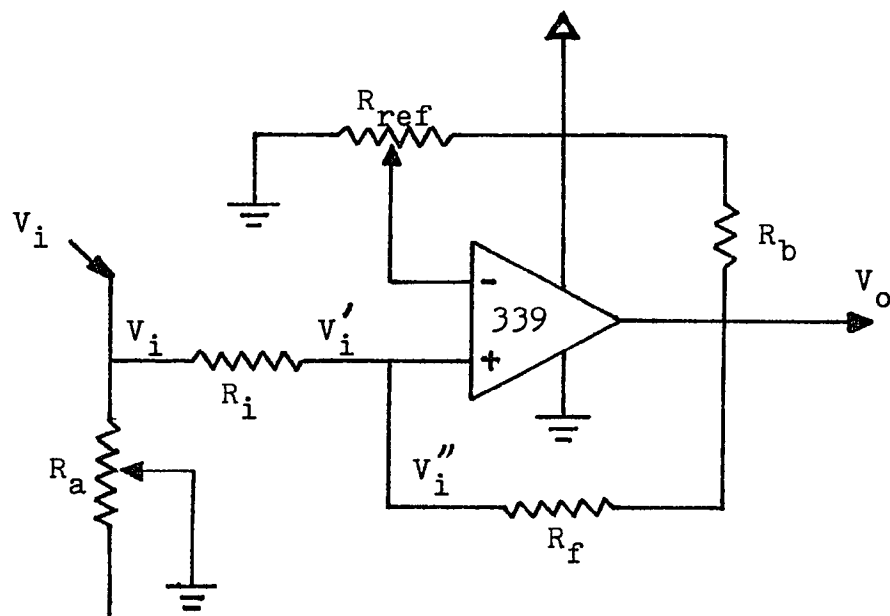

Figure 38. Schematic diagram of a non-inverting comparator with hysteresis.

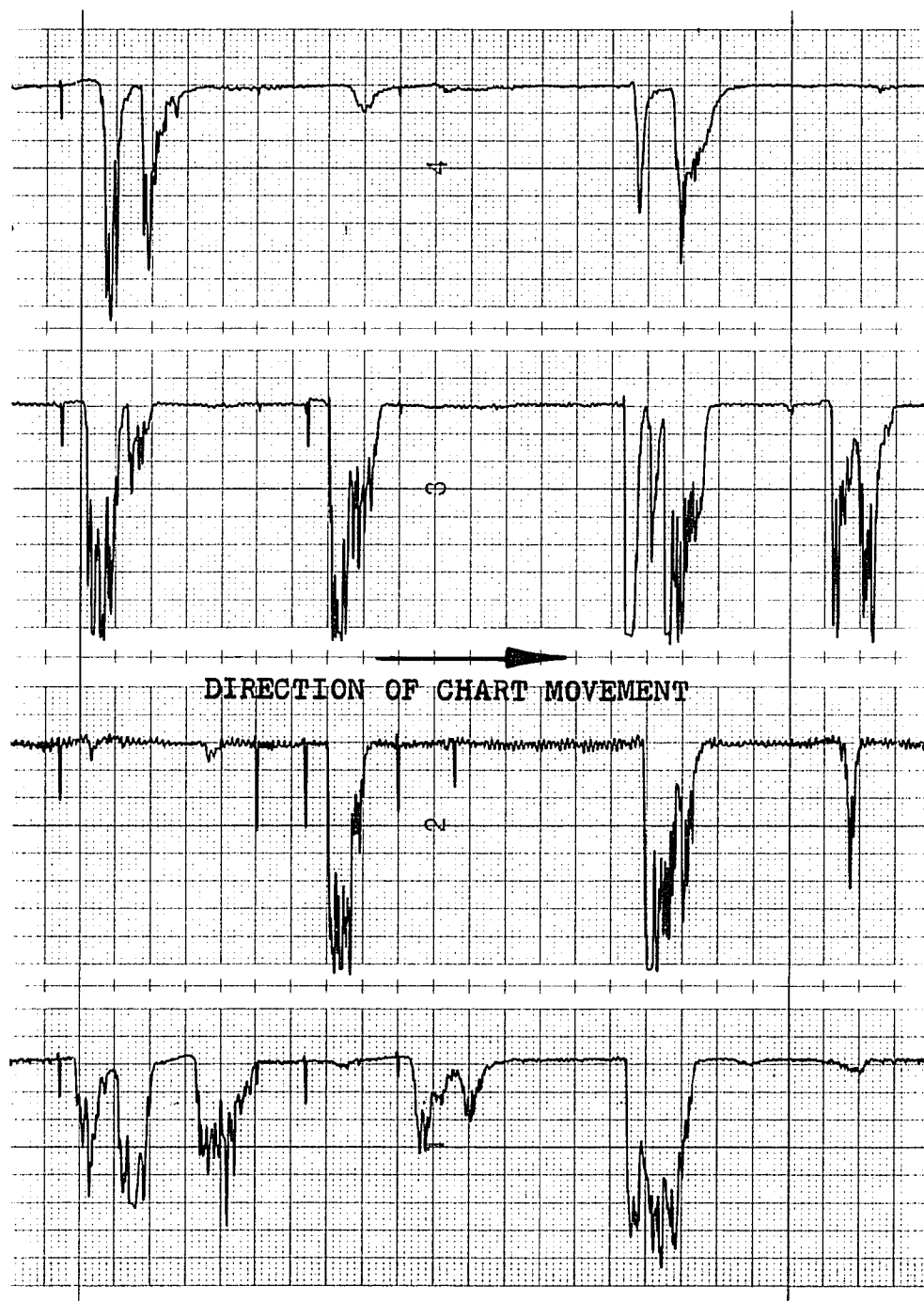

Figure 38A. An actual amplifier circuit output activated by the probe.

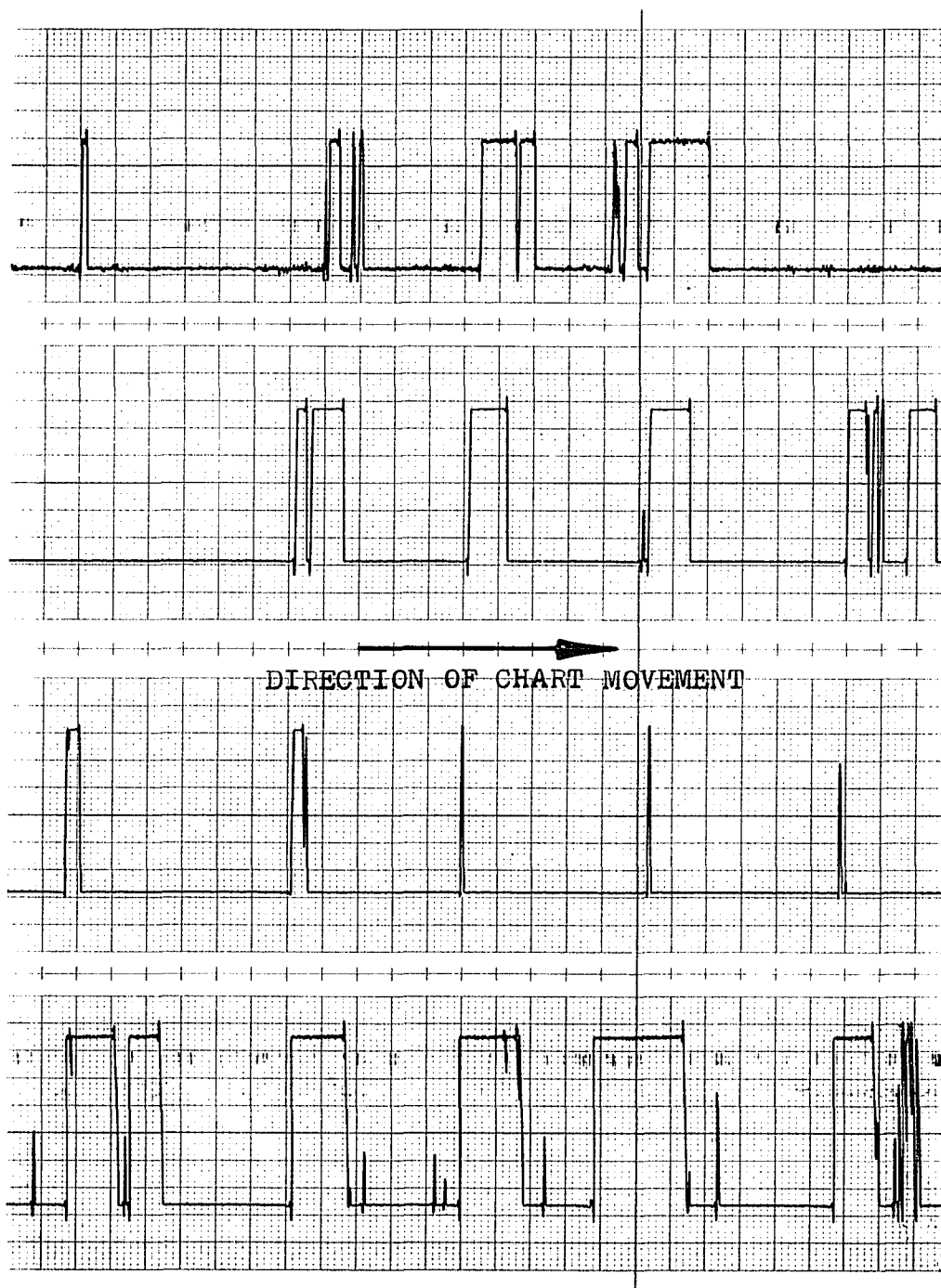

Figure 38B. An actual comparator output without the hysteresis effect.

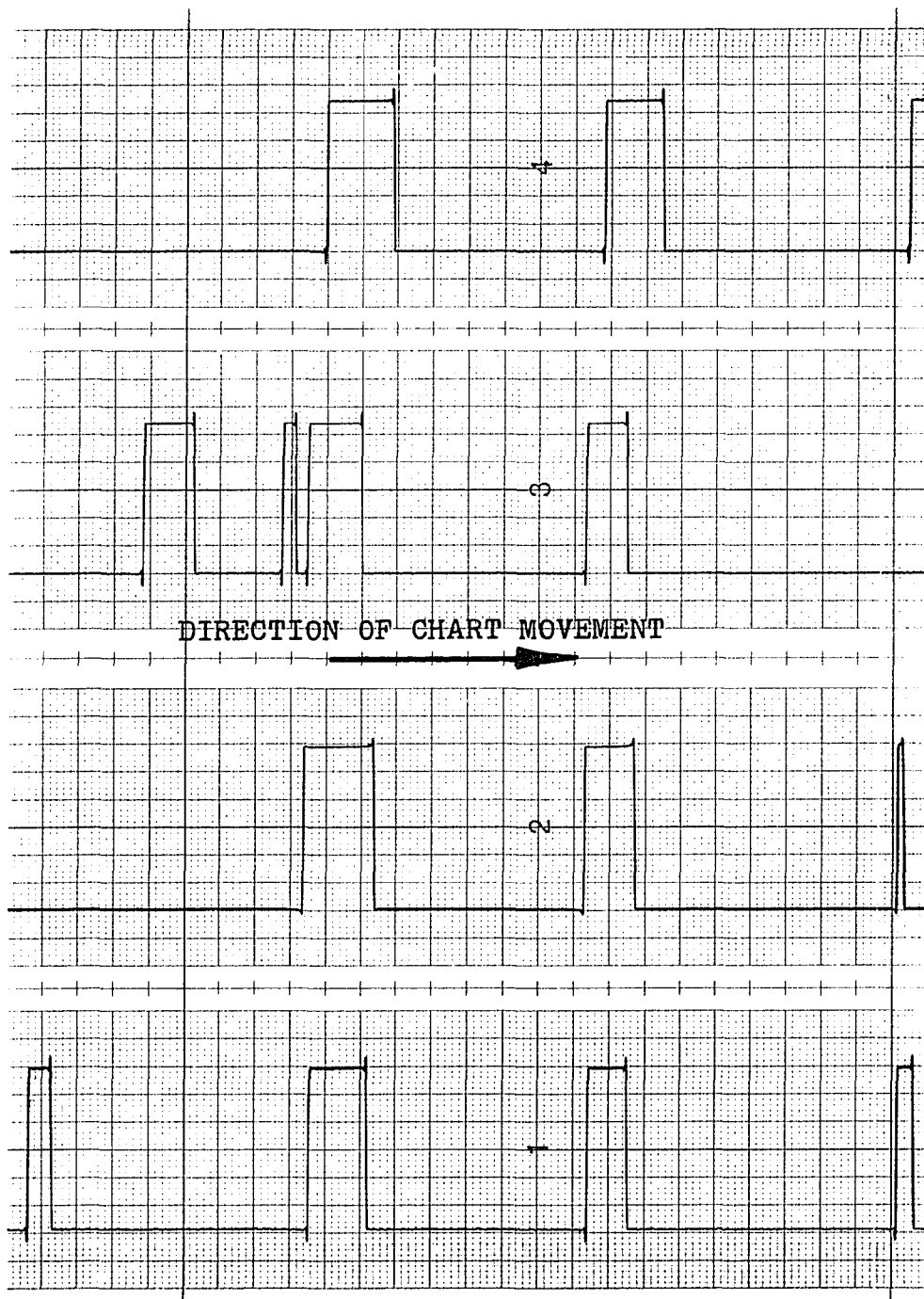

Figure 39. An actual comparator output recorded on a chart with the hysteresis effect.

The voltage of V_{H1} is

$$V_{H1} = V_{ref} \left(\frac{R_i + R_f}{R_f} \right). \quad (42)$$

The second set point (V_{H2}) is set near the lower sensor signal limit. For the signal voltage below V_{H2} ,

$$V_i + (V_0 - V_i) \left(\frac{R_i}{R_i + R_f} \right) < V_{ref} \quad (43)$$

the comparator output will be reset. The second set point value is

$$V_{H2} = \left[V_{ref} - V_0 \left(\frac{R_i}{R_i + R_f} \right) \right] \left(\frac{R_i + R_f}{R_f} \right) \quad (44)$$

This method of switching the comparator output provides hysteresis by incorporating positive feed back in the comparator circuit, where the width of the hysteresis window (ΔV) is

$$V_{H1} - V_{H2} = V_0 \frac{R_i}{R_f} \quad (45)$$

Figure 40 shows this kind of input-output characteristic. The noise immunity of the circuit is greatly improved because of the hysteresis.

Once the signal width, hysteresis window width, and signal bias becomes known, V_{H1} and V_{H2} can be set

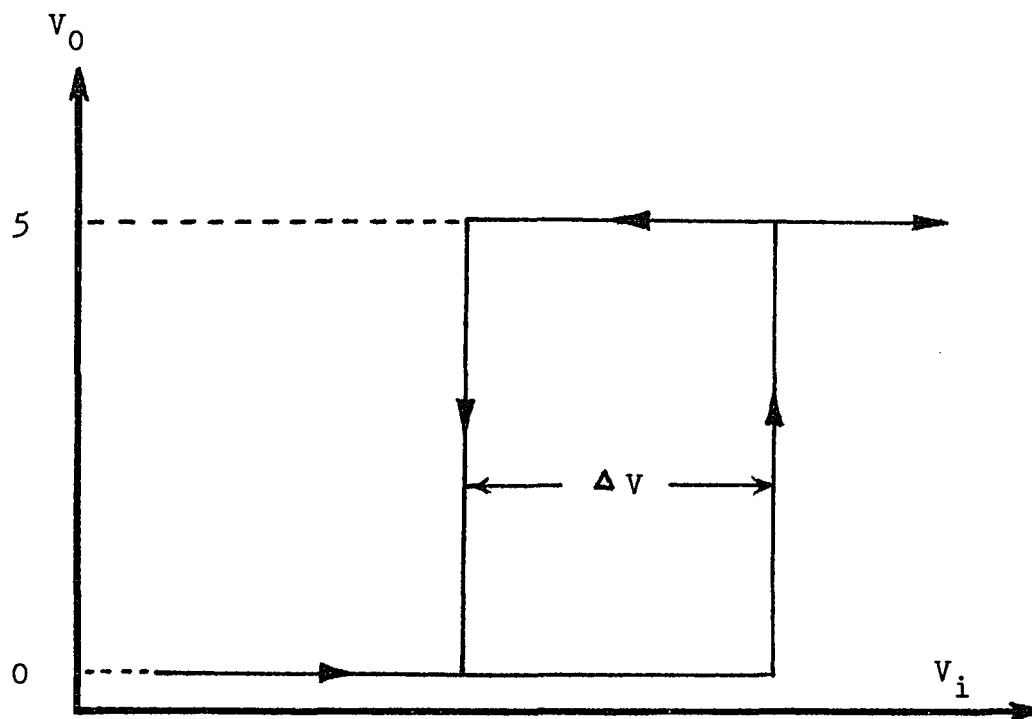

Figure 40. Input-output characteristic of a comparator with hysteresis.

indirectly by using V_{ref} . The detailed procedure is as follows:

1. Measure the V_i at high and at low to determine the signal width.
2. Calculate the hysteresis window width by Equation (45).
3. Adjust the attenuator to bring the ratio of the signal width to the hysteresis window width below 1.25 in order to get a better result.
4. Set V_{ref} value in between V_i at high and V_i at low by adjusting R_{ref} .
5. Determine V_{H1} and V_{H2} by Equation (42) and Equation (44) respectively.

APPENDIX D

DATA COLLECTED FOR
BUBBLE CHARACTERISTICS ANALYSIS

3-D BED PROBE POSITION=(8CM,55CM)

SUPERFICIAL GAS VELOCITY=12.46CM/SEC PARTICLE SIZE:250-355

UB	AL	RF	RR	RW	VB	DE	SHAPE
68.18	6.68	3.42	0.78	4.53	167.5	6.84	S.G.D.
83.33	7.33	4.02	2.09	16.51	268.1	8.00	S.G.D.
65.22	4.57	4.57	4.52	16.61	219.9	7.49	S.G.D.
78.95	7.42	4.07	2.30	--	275.9	8.08	S.G.
75.00	6.60	4.02	2.43	5.01	259.2	7.91	S.G.D.
65.22	5.35	3.49	2.80	16.61	157.0	6.69	S.G.D.
88.24	6.35	6.72	6.64	16.48	682.8	10.93	S.G.D.
75.00	7.35	3.32	5.26	15.14	318.7	8.47	P.C.
93.75	5.62	12.16	10.25	--	1022.2	12.53	S.L.
71.43	6.71	3.48	1.28	--	175.7	6.95	S.G.
83.33	7.67	4.02	1.55	16.51	271.7	8.04	S.G.D.
83.33	8.17	4.02	7.00	--	628.6	10.63	PAR.
55.56	1.56	13.65	13.62	13.65	909.2	12.02	S.G.D.
83.33	9.17	3.32	5.56	--	445.5	9.48	PAR.
62.50	6.50	3.48	1.58	16.62	174.5	6.93	S.G.D.
71.43	5.57	4.06	3.59	16.57	224.0	7.54	S.G.D.
71.43	6.57	3.59	2.00	--	189.9	7.13	S.G.
88.24	8.29	3.50	6.20	--	501.0	9.85	PAR.
75.00	5.85	4.55	4.16	16.55	295.2	8.26	S.G.D.
83.33	8.33	4.02	7.07	--	654.5	10.77	PAR.
100.00	8.40	3.64	6.87	--	623.4	10.60	PAR.
83.33	7.83	4.02	1.30	--	272.5	8.04	S.G.
78.95	10.11	5.45	2.84	--	668.6	10.85	S.G.
88.24	8.12	3.44	5.87	--	439.9	9.44	PAR.
93.75	8.06	3.36	5.96	12.16	448.0	9.49	P.C.
83.33	7.50	4.02	2.03	--	269.5	8.01	S.G.
71.43	5.43	4.06	3.66	16.57	218.1	7.47	S.G.D.
68.18	6.14	3.51	2.33	--	173.4	6.92	S.G.
78.95	6.63	3.30	4.55	16.53	215.7	7.44	P.C.
88.24	7.94	3.44	6.24	16.48	485.1	9.75	P.C.
75.00	6.60	7.80	7.71	--	766.2	11.38	S.L.
75.00	7.35	3.32	5.23	16.55	315.1	8.44	P.C.
55.56	1.56	13.65	11.47	16.35	395.2	9.10	S.L.D.
88.24	5.29	6.72	6.72	16.48	533.7	10.06	S.G.D.
68.18	4.77	4.53	4.45	16.59	229.9	7.60	S.G.D.
78.95	7.26	4.07	2.30	16.53	274.6	8.06	S.G.D.
107.14	13.07	3.33	7.18	16.38	1056.1	12.63	P.C.

65.22	6.39	4.10	3.17	16.61	258.4	7.90	S.G.D.
88.24	8.12	3.44	6.31	16.48	507.0	9.89	P.C.
83.33	8.00	4.02	0.63	---	273.1	8.05	S.G.
62.50	6.50	3.48	1.58	16.28	174.5	6.93	S.G.D.
78.95	8.68	3.41	5.95	---	482.3	9.73	PAR.
75.00	6.90	4.02	2.30	6.37	263.3	7.95	S.G.D.
93.75	10.69	5.46	1.38	16.45	681.4	10.92	S.G.D.
83.33	7.83	4.02	1.17	16.51	272.7	8.05	S.G.D.
65.22	5.87	3.41	2.20	16.61	158.6	6.72	S.G.D.
88.24	6.35	6.72	6.71	---	583.9	10.40	S.L.
71.43	3.57	6.79	5.98	---	224.3	7.56	S.L.
88.24	6.00	6.72	6.69	16.48	633.6	10.66	S.G.D.
78.95	8.84	3.41	6.00	---	500.0	9.85	PAR.
78.95	6.32	4.19	3.62	---	261.8	7.94	S.G.
83.33	6.83	4.57	3.64	13.65	348.6	8.73	S.G.D.
78.95	7.58	4.07	2.06	---	278.2	8.10	S.G.
65.22	5.87	3.54	2.49	16.25	173.9	6.93	S.G.D.
88.24	5.82	6.72	6.66	---	509.4	9.94	S.L.
65.22	4.57	4.57	4.52	16.61	219.9	7.49	S.G.D.
93.75	9.37	3.36	6.26	16.45	576.1	10.32	P.C.
100.00	11.40	7.80	3.55	3.55	1884.1	15.32	S.G.D.
65.22	6.26	3.49	1.97	16.61	174.1	6.93	S.G.D.
107.14	13.07	3.33	7.18	16.38	1056.1	12.63	P.C.
71.43	3.43	8.49	7.93	16.57	418.8	9.28	S.L.D.
88.24	5.65	6.72	6.71	16.48	583.8	10.37	S.G.D.
100.00	9.20	7.80	7.18	16.41	1411.1	13.92	S.G.D.
78.95	8.68	7.64	3.76	4.07	1631.2	14.60	S.G.D.
83.33	7.67	4.02	1.71	---	271.3	8.03	S.G.
71.43	3.57	8.49	6.92	---	292.6	8.26	S.L.
83.33	8.17	4.02	7.79	16.51	775.2	11.40	P.C.
93.75	6.00	12.16	10.48	---	1148.9	13.03	S.L.
83.33	8.33	4.02	7.07	---	654.5	10.77	PAR.
100.00	9.40	7.80	7.63	---	1295.2	13.52	S.G.
100.00	11.60	6.03	2.29	---	913.1	12.04	S.G.
93.75	7.87	3.36	6.32	8.27	480.4	9.72	P.C.
88.24	6.18	6.72	6.67	16.48	658.3	10.79	S.G.D.
93.75	11.44	3.46	7.06	---	896.7	11.96	PAR.
75.00	7.50	3.32	5.00	---	294.5	8.25	PAR.
83.33	7.50	4.12	2.35	---	286.0	8.17	S.G.
71.43	3.57	5.68	5.27	---	179.8	7.02	S.L.
78.95	5.53	4.19	3.80	16.53	236.7	7.67	S.G.D.
93.75	8.44	3.36	5.58	---	412.9	9.24	PAR.
100.00	8.60	4.08	7.44	---	746.8	11.26	PAR.
75.00	7.35	3.32	4.95	---	282.9	8.14	PAR.
88.24	6.18	4.52	3.99	16.48	309.2	8.39	S.G.D.
55.56	1.78	10.33	5.79	---	96.6	5.71	S.L.
75.00	5.55	4.11	3.67	16.55	228.1	7.58	S.G.D.
88.24	7.94	3.50	6.57	16.48	536.9	10.08	P.C.
62.50	6.50	3.48	1.49	9.26	174.7	6.94	S.G.D.
78.95	8.05	3.65	6.77	---	580.6	10.35	PAR.

68.18	6.68	3.62	1.95	---	196.0	7.21	S.G.
93.75	6.37	8.27	8.05	---	784.8	11.48	S.L.
83.33	7.67	4.02	1.55	16.51	271.7	8.04	S.G.D.
71.43	6.43	3.59	2.20	---	187.9	7.11	S.G.
88.24	6.18	4.52	3.99	16.48	309.2	8.39	S.G.D.
68.18	6.55	3.46	1.58	---	172.4	6.91	S.G.
88.24	7.94	3.39	5.58	---	388.6	9.05	PAR.
88.24	5.65	6.72	6.64	---	484.9	9.77	S.L.
71.43	5.57	4.06	3.77	---	215.2	7.44	S.G.
88.24	7.94	3.44	6.24	16.48	485.1	9.75	P.C.
65.22	6.26	3.49	2.13	---	173.3	6.92	S.G.
75.00	10.50	3.50	6.96	---	799.3	11.51	PAR.
93.75	9.37	3.36	5.88	---	509.8	9.91	PAR.

3-D BED PROBE POSITION=(0CM,55CM)

SUPERFICIAL GAS VELOCITY=12.46CM/SEC PARTICLE SIZE:250-355

UB	AL	RF	RR	RW	VB	DE	SHAPE
75.00	5.55	4.11	3.67	16.55	228.1	7.58	S.G.D.
83.33	6.83	4.57	3.64	13.65	348.6	8.73	S.G.D.
107.14	5.79	7.33	7.16	---	567.5	10.30	S.L.
68.18	6.82	3.62	1.72	---	197.5	7.23	S.G.
93.75	10.69	5.46	1.38	16.45	681.4	10.92	S.G.D.
55.56	1.89	10.33	5.95	---	108.7	5.94	S.L.
93.75	11.06	3.46	6.95	---	838.8	11.70	PAR.
75.00	7.35	3.32	4.95	---	282.9	8.14	PAR.
71.43	3.57	5.68	5.27	---	179.8	7.02	S.L.
93.75	8.44	3.36	5.58	---	412.9	9.24	PAR.
100.00	11.60	3.33	6.72	16.41	820.8	11.62	P.C.
78.95	5.53	4.19	3.80	16.53	236.7	7.67	S.G.D.
68.18	6.14	3.51	2.33	---	173.4	6.92	S.G.
78.95	8.53	3.41	6.31	16.53	532.2	10.05	P.C.
78.95	8.05	3.65	6.77	---	580.6	10.35	PAR.
88.24	9.71	3.39	4.86	---	359.4	8.82	PAR.
88.24	7.94	3.50	6.57	16.48	536.9	10.08	P.C.
100.00	8.60	4.08	7.44	---	746.8	11.26	PAR.
78.95	7.26	4.07	2.52	---	273.0	8.05	S.G.
88.24	5.65	6.72	6.71	16.48	583.8	10.37	S.G.D.
88.24	9.71	3.44	6.91	16.48	725.4	11.15	P.C.
93.75	5.25	12.16	10.00	---	901.3	12.02	S.L.
88.24	5.29	6.72	6.72	16.48	533.7	10.06	S.G.D.
93.75	10.50	3.52	7.10	---	831.3	11.67	PAR.
100.00	11.80	6.03	1.73	---	915.7	12.05	S.G.
65.22	6.78	3.54	1.23	8.87	185.7	7.08	S.G.D.
78.95	7.42	4.07	2.30	---	275.9	8.08	S.G.
93.75	8.25	3.36	5.87	16.45	445.9	9.48	P.C.
55.56	1.78	10.33	8.04	16.66	205.6	7.32	S.L.D.
78.95	8.68	3.41	6.37	16.53	552.1	10.18	P.C.
107.14	6.00	7.33	7.20	---	602.3	10.51	S.L.
65.22	6.39	4.10	3.17	16.61	258.4	7.90	S.G.D.
83.33	8.00	4.02	0.63	---	273.1	8.05	S.G.
88.24	8.29	3.44	5.94	---	459.3	9.57	PAR.
78.95	10.11	5.45	2.84	---	668.6	10.85	S.G.
68.18	6.55	3.46	1.58	---	172.4	6.91	S.G.
93.75	10.87	5.46	0.71	---	682.1	10.92	S.G.

83.33	10.83	4.18	4.39	16.51	328.1	8.56	P.C.
88.24	8.29	3.50	6.20	--	501.0	9.85	PAR.
115.38	12.23	3.39	6.91	--	916.4	12.05	PAR.
75.00	6.90	4.02	2.30	6.37	263.3	7.95	S.G.D.
88.24	5.29	6.72	6.72	16.48	533.7	10.06	S.G.D.
88.24	6.00	6.72	6.69	16.48	633.6	10.66	S.G.D.
62.50	6.50	3.48	1.58	16.62	174.5	6.93	S.G.D.
78.95	7.26	4.07	2.52	--	273.0	8.05	S.G.
75.00	10.50	3.45	6.71	--	742.2	11.23	PAR.
93.75	11.06	3.46	6.95	--	838.8	11.70	PAR.
107.14	13.07	3.33	7.18	16.38	1056.1	12.63	P.C.
107.14	15.21	3.50	5.16	7.33	2110.6	15.91	P.C.
107.14	5.79	10.71	9.51	--	923.3	12.11	S.L.
83.33	7.33	4.02	2.09	16.51	268.1	8.00	S.G.D.
93.75	8.06	3.36	5.96	12.16	448.0	9.49	P.C.
93.75	10.69	5.46	1.58	--	681.2	10.92	S.G.
62.50	6.50	3.48	1.49	9.26	174.7	6.94	S.G.D.
75.00	7.35	3.32	5.23	16.55	315.1	8.44	P.C.
88.24	7.94	3.44	6.24	16.48	485.1	9.75	P.C.
71.43	3.57	5.68	5.27	--	179.8	7.02	S.L.
93.75	10.69	4.56	9.25	--	1435.4	14.00	PAR.
88.24	7.94	3.50	6.57	16.48	536.9	10.08	P.C.
93.75	10.69	3.52	7.16	--	861.2	11.80	PAR.
78.95	5.53	4.19	3.80	16.53	236.7	7.67	S.G.D.
68.18	6.68	3.62	1.95	--	196.0	7.21	S.G.
88.24	5.29	6.72	6.72	16.48	533.7	10.06	S.G.D.
65.22	5.87	3.54	2.49	16.25	173.9	6.93	S.G.D.
93.75	10.69	5.46	1.38	16.45	681.4	10.92	S.G.D.
83.33	10.50	3.54	7.18	--	850.2	11.75	PAR.
71.43	6.43	3.59	2.20	--	187.9	7.11	S.G.
88.24	5.47	6.72	6.72	16.48	558.7	10.22	S.G.D.
83.33	7.83	4.02	1.17	16.51	272.7	8.05	S.G.D.
88.24	9.71	3.44	6.91	16.48	725.4	11.15	P.C.
83.33	4.83	5.92	5.92	16.51	374.8	8.95	S.G.D.
88.24	6.18	6.72	6.70	--	558.9	10.25	S.L.
71.43	6.71	3.48	1.16	15.86	175.8	6.95	S.G.D.
107.14	6.43	10.71	9.82	--	1112.0	12.89	S.L.
93.75	10.31	8.27	5.84	6.37	2000.6	15.63	S.G.D.
75.00	6.60	3.55	1.43	5.01	186.2	7.09	S.G.D.
83.33	7.50	4.12	2.35	--	286.0	8.17	S.G.
93.75	11.44	3.46	7.06	--	896.7	11.96	PAR.
93.75	7.87	3.36	6.32	8.27	480.4	9.72	P.C.
107.14	7.07	5.68	5.50	--	521.6	9.99	S.G.
93.75	11.06	3.46	6.95	--	838.8	11.70	PAR.
88.24	7.94	3.39	5.58	--	388.6	9.05	PAR.
71.43	6.29	3.59	2.19	16.57	186.9	7.09	S.G.D.
83.33	7.67	4.02	1.71	--	271.3	8.03	S.G.
78.95	8.84	3.41	6.00	--	500.0	9.85	PAR.

75.00	7.05	3.55	0.57	16.55	187.8	7.11	S.G.D.
78.95	6.63	3.30	4.55	16.53	215.7	7.44	F.C.
83.33	4.83	5.92	5.92	16.51	374.8	8.95	S.G.D.
88.24	8.12	3.44	5.87	--	439.9	9.44	FAR.
78.95	7.58	4.07	1.86	16.53	278.9	8.11	S.G.D.
65.22	5.87	3.41	2.20	16.61	158.6	6.72	S.G.D.
78.95	9.95	5.45	3.09	--	664.2	10.83	S.G.
71.43	5.57	4.06	3.77	--	215.2	7.44	S.G.
88.24	6.18	6.72	6.70	--	558.9	10.25	S.L.
78.95	7.26	3.34	5.09	--	295.2	8.26	FAR.
88.24	5.12	6.72	6.53	--	412.8	9.26	S.L.
93.75	9.37	3.36	6.44	12.16	606.7	10.50	F.C.
88.24	8.47	3.57	4.27	5.54	818.1	11.60	F.C.
93.75	13.50	3.36	7.06	--	1057.0	12.64	FAR.
83.33	13.17	3.54	4.02	5.05	1718.8	14.86	F.C.

3-D BED PROBE POSITION=(2CM,55CM)

SUPERFICIAL GAS VELOCITY=12.46CM/SEC PARTICLE SIZE:250-355

UB	AL	RF	RR	RW	VB	DE	SHAPE
93.75	11.81	3.60	4.97	---	457.4	9.56	PAR.
88.24	6.88	8.94	8.70	---	988.8	12.39	S.L.
65.22	5.22	4.57	4.39	16.61	260.7	7.93	S.G.D.
88.24	5.65	3.44	2.64	---	156.0	6.68	S.G.
83.33	8.50	7.22	6.70	16.51	1108.6	12.84	S.G.D.
55.56	1.78	10.33	5.79	---	96.6	5.71	S.L.
83.33	6.83	4.57	3.64	13.65	348.6	8.73	S.G.D.
83.33	7.33	4.02	2.09	16.51	268.1	8.00	S.G.D.
93.75	6.00	5.46	5.43	---	391.4	9.08	S.G.
65.22	6.00	7.24	7.13	---	592.4	10.45	S.L.
65.22	6.26	3.49	1.97	16.61	174.1	6.93	S.G.D.
68.18	4.50	4.53	4.53	---	192.8	7.19	S.L.
88.24	6.18	6.72	6.67	16.48	658.3	10.79	S.G.D.
60.00	5.04	4.99	4.99	---	263.9	7.96	S.G.
78.95	8.05	9.73	9.58	---	1434.7	14.03	S.L.
68.18	4.91	4.02	3.73	11.18	196.3	7.21	S.G.D.
83.33	6.50	4.02	3.17	---	246.7	7.78	S.G.
83.33	7.00	3.42	5.39	---	319.7	8.48	PAR.
51.72	9.21	3.46	7.18	11.09	735.4	11.20	P.C.
71.43	3.57	5.68	5.27	---	179.8	7.02	S.L.
83.33	4.83	4.12	4.06	---	184.0	7.06	S.G.
75.00	7.35	3.32	5.23	16.55	315.1	8.44	P.C.
93.75	7.87	3.36	6.32	8.27	480.4	9.72	P.C.
78.95	7.74	3.58	6.33	---	487.2	9.76	PAR.
100.00	9.20	3.42	6.13	---	543.9	10.13	PAR.
75.00	7.50	3.32	5.00	---	294.5	8.25	PAR.
50.00	5.90	5.49	5.34	16.69	427.0	9.34	S.G.D.
100.00	10.00	3.55	7.07	---	785.4	11.45	PAR.
83.33	10.83	4.18	4.39	16.51	328.1	8.56	P.C.
68.18	5.18	8.53	8.47	16.59	798.1	11.51	S.L.D.
88.24	9.71	3.39	4.86	---	359.4	8.82	PAR.
78.95	7.11	5.45	4.66	9.73	539.5	10.10	S.G.D.
93.75	8.25	3.30	4.69	6.38	424.9	9.33	P.C.
78.95	7.26	4.07	2.52	---	273.0	8.05	S.G.
88.24	8.12	3.44	5.87	---	439.9	9.44	PAR.
83.33	4.83	5.92	5.82	---	316.3	8.48	S.L.
78.95	7.26	3.37	5.25	---	314.9	8.44	PAR.
65.22	6.26	7.24	7.17	---	634.3	10.69	S.L.
88.24	7.94	3.39	5.58	---	388.6	9.05	PAR.
93.75	10.12	3.36	6.11	---	594.6	10.43	PAR.

55.56	1.78	10.33	8.04	16.66	205.6	7.32	S.L.D.
60.00	6.24	3.99	3.30	--	234.0	7.65	S.G.
115.38	9.69	3.34	4.93	6.85	688.6	10.96	P.C.
78.95	6.32	4.19	3.62	--	261.8	7.94	S.G.
83.33	11.00	4.18	4.31	--	320.7	8.49	PAR.
78.95	12.47	3.46	7.40	--	1071.6	12.70	PAR.
107.14	9.21	3.43	6.22	--	560.1	10.23	PAR.
50.00	4.60	4.08	4.05	--	169.3	6.86	S.G.
60.00	6.00	5.44	5.26	16.63	428.5	9.35	S.G.D.
57.69	2.88	9.98	7.02	--	235.8	7.69	S.L.
78.95	7.26	4.07	2.30	16.53	274.6	8.06	S.G.D.
78.95	8.68	3.41	5.95	--	482.3	9.73	PAR.
93.75	5.25	4.56	4.51	--	243.6	7.75	S.G.
93.75	8.06	3.36	5.96	12.16	448.0	9.49	P.C.
93.75	6.00	12.16	10.48	--	1148.9	13.03	S.L.
107.14	7.71	4.02	1.61	--	271.7	8.04	S.G.
100.00	7.40	6.03	5.87	--	612.5	10.54	S.G.
55.56	8.78	3.33	7.01	16.66	676.5	10.89	P.C.
88.24	5.29	6.72	6.57	--	436.5	9.44	S.L.
78.95	4.26	3.58	3.51	--	123.3	6.18	S.G.
75.00	5.25	5.01	5.00	--	282.2	8.14	S.G.
62.50	6.12	3.57	2.33	16.62	182.3	7.04	S.G.D.
75.00	7.50	3.32	5.00	--	294.5	8.25	PAR.
88.24	8.12	3.44	6.31	16.48	507.0	9.89	P.C.
60.00	4.20	7.80	7.61	16.31	496.3	9.82	S.L.D.
53.57	5.46	4.02	3.76	--	206.7	7.34	S.G.
88.24	7.94	3.39	5.58	--	388.6	9.05	PAR.
88.24	5.12	6.72	6.53	--	412.8	9.26	S.L.
75.00	3.00	5.01	4.59	--	113.4	6.02	S.L.
65.22	5.87	3.41	2.20	16.25	158.7	6.72	S.G.D.
78.95	5.37	3.58	3.10	--	162.2	6.77	S.G.
115.38	9.69	3.34	6.56	9.98	648.3	10.74	P.C.
51.72	3.52	6.78	5.94	--	217.9	7.49	S.L.
83.33	11.17	3.48	6.13	9.26	1142.2	12.97	P.C.
78.95	10.42	3.58	7.35	--	883.9	11.91	PAR.
75.00	8.40	3.30	4.90	--	316.7	8.46	PAR.
65.22	4.04	8.87	7.44	--	386.5	9.06	S.L.
75.00	7.65	3.32	5.05	--	306.4	8.36	PAR.
75.00	8.25	3.55	7.00	16.55	633.3	10.65	P.C.
100.00	9.20	7.80	7.18	16.41	1411.1	13.92	S.G.D.
68.18	6.27	3.46	2.02	--	169.6	6.87	S.G.
93.75	7.50	4.13	2.11	12.16	289.8	8.21	S.G.D.
100.00	11.20	3.64	8.80	16.41	1352.6	13.72	P.C.
62.50	5.62	4.52	4.20	16.62	278.7	8.10	S.G.D.
93.75	4.50	12.16	9.44	--	678.0	10.93	S.L.
88.24	15.18	3.32	6.38	--	971.1	12.29	PAR.
62.50	8.50	3.35	4.87	16.62	316.7	8.46	P.C.
71.43	6.86	5.05	4.43	16.57	429.1	9.36	S.G.D.

65.22	6.39	3.54	1.94	16.25	182.2	7.03	S.G.D.
88.24	6.00	3.65	2.36	6.72	191.5	7.15	S.G.D.
71.43	7.29	3.36	5.20	--	309.0	8.39	PAR.
83.33	4.83	5.92	5.92	16.51	374.8	8.95	S.G.D.
57.69	4.62	8.10	7.97	16.65	609.4	10.52	S.L.D.
88.24	5.82	6.72	6.66	--	509.4	9.94	S.L.
71.43	6.43	3.59	2.20	--	187.9	7.11	S.G.
53.57	2.68	4.99	4.42	--	92.4	5.62	S.L.
75.00	7.35	3.30	5.07	16.55	296.7	8.28	P.C.
78.95	8.05	6.33	6.10	--	743.7	11.24	S.G.
115.38	13.38	3.31	6.40	16.33	859.2	11.79	P.C.
55.56	6.22	3.36	1.61	16.66	156.3	6.68	S.G.D.

3-D BED PROBE POSITION=(4CM,55CM)

SUPERFICIAL GAS VELOCITY=12.46CM/SEC PARTICLE SIZE:250-355

UB	AL	RF	RR	RW	VB	DE	SHAPE
45.45	4.64	7.64	7.55	16.22	556.1	10.20	S.L.D.
57.69	6.46	6.85	6.84	--	616.1	10.59	S.L.
62.50	6.87	5.05	4.71	--	409.3	9.21	S.G.
55.56	1.78	10.33	5.79	--	96.6	5.71	S.L.
93.75	7.12	4.56	3.78	--	349.1	8.74	S.G.
75.00	7.65	3.45	5.73	--	394.0	9.10	FAR.
78.95	5.53	4.19	3.80	16.53	236.7	7.67	S.G.D.
115.38	11.54	3.45	4.24	5.47	600.4	10.47	F.C.
60.00	4.68	5.44	5.39	--	267.1	8.01	S.L.
78.95	6.63	3.30	4.55	16.53	215.7	7.44	F.C.
83.33	10.83	4.18	4.39	16.51	328.1	8.56	F.C.
78.95	7.26	3.34	5.09	--	295.2	8.26	FAR.
68.18	6.82	3.35	5.00	--	267.7	8.00	FAR.
88.24	7.94	3.39	5.58	--	388.6	9.05	FAR.
71.43	8.43	3.59	3.79	4.59	848.7	11.75	F.C.
115.38	10.85	3.63	6.49	9.98	1369.3	13.78	F.C.
88.24	10.06	3.30	5.49	--	476.8	9.69	FAR.
88.24	6.35	6.72	6.64	16.48	682.8	10.93	S.G.D.
88.24	8.12	3.44	5.87	--	439.9	9.44	FAR.
88.24	9.71	3.30	5.67	16.48	489.4	9.78	F.C.
75.00	6.90	3.40	5.25	--	299.1	8.30	FAR.
65.22	6.26	3.60	2.24	16.61	187.5	7.10	S.G.D.
78.95	8.53	3.41	6.31	16.53	532.2	10.05	F.C.
62.50	4.62	3.52	3.35	--	133.2	6.34	S.G.
93.75	7.87	3.36	6.32	8.27	480.4	9.72	F.C.
88.24	5.65	6.72	6.71	16.48	583.8	10.37	S.G.D.
88.24	5.12	6.72	6.72	16.48	508.6	9.90	S.L.D.
62.50	6.12	3.33	1.80	--	151.3	6.61	S.G.
57.69	7.27	4.09	2.57	--	276.5	8.08	S.G.
107.14	18.43	4.67	5.26	--	800.2	11.52	FAR.
100.00	7.80	3.33	4.54	--	253.0	7.85	FAR.
71.43	5.29	4.59	4.53	--	247.9	7.79	S.G.
62.50	5.50	4.09	3.67	16.62	224.4	7.54	S.G.D.
57.69	4.96	9.98	8.63	--	644.1	10.74	S.L.
83.33	11.00	4.18	4.31	--	320.7	8.49	FAR.
78.95	5.68	7.64	7.10	7.64	995.5	12.39	S.G.D.
57.69	6.92	3.54	1.01	--	184.9	7.07	S.G.
57.69	6.23	3.39	1.70	16.65	160.2	6.74	S.G.D.
78.95	7.26	4.07	2.52	--	273.0	8.05	S.G.

71.43	4.29	8.49	7.38	--	407.6	9.22	S.L.
65.22	6.78	5.48	5.07	16.61	500.8	9.85	S.G.D.
60.00	5.52	5.44	5.44	--	344.8	8.70	S.G.
50.00	3.20	6.80	6.39	16.69	251.2	7.83	S.L.D.
55.56	4.33	10.33	8.41	--	523.9	10.03	S.L.
65.22	5.35	16.25	16.15	16.61	4202.8	20.02	S.G.D.
57.69	5.54	3.45	2.75	--	154.8	6.66	S.G.
65.22	9.78	3.49	6.71	--	691.5	10.97	FAR.
53.57	2.68	4.56	4.16	--	82.7	5.42	S.L.
88.24	8.29	3.44	5.94	--	459.3	9.57	FAR.
57.69	7.15	3.58	0.27	16.65	192.7	7.17	S.G.D.
100.00	9.20	3.55	4.44	--	284.9	8.16	FAR.
60.00	4.20	4.55	4.54	16.63	194.9	7.19	S.G.D.
68.18	6.82	4.02	2.90	--	255.9	7.88	S.G.
53.57	2.68	4.56	4.16	--	82.7	5.42	S.L.
78.95	8.53	3.41	6.31	16.53	532.2	10.05	P.C.
100.00	8.00	3.33	4.60	--	266.1	7.98	FAR.
65.22	4.83	4.84	4.19	4.84	325.0	8.53	S.G.D.
88.24	8.12	3.50	6.64	16.48	561.1	10.23	P.C.
57.69	5.77	3.54	2.74	--	168.6	6.85	S.G.
83.33	8.17	4.02	7.79	16.51	775.2	11.40	P.C.
78.95	8.05	3.65	6.77	--	580.6	10.35	FAR.
107.14	9.00	3.59	6.87	--	668.0	10.85	FAR.
78.95	8.84	3.34	5.61	--	437.5	9.42	FAR.
78.95	5.37	4.97	4.58	7.64	346.4	8.71	S.G.D.
65.22	6.39	3.54	1.94	16.25	182.2	7.03	S.G.D.
65.22	8.87	3.41	6.00	--	501.6	9.86	FAR.
100.00	10.40	3.33	5.25	--	449.7	9.51	FAR.
83.33	9.67	4.57	10.04	16.51	1510.6	14.24	P.C.
53.57	2.57	4.99	4.37	--	85.9	5.49	S.L.
88.24	6.00	3.65	2.36	6.72	191.5	7.15	S.G.D.
75.00	7.35	3.32	4.95	--	282.9	8.14	FAR.
83.33	7.67	3.32	5.09	--	311.6	8.41	FAR.
115.38	7.85	6.85	5.62	6.85	1030.4	12.53	S.G.D.
78.95	6.63	3.30	4.46	--	207.2	7.34	FAR.
53.57	6.11	4.02	3.44	--	233.1	7.64	S.G.
65.22	4.57	3.66	3.54	--	139.9	6.44	S.G.
71.43	5.86	4.59	4.41	--	283.9	8.15	S.G.
93.75	6.19	8.27	8.01	--	746.9	11.29	S.L.
71.43	5.86	3.59	2.60	16.57	179.0	6.99	S.G.D.
44.12	4.24	8.94	8.64	16.72	642.3	10.70	S.L.D.
71.43	7.43	5.68	5.06	15.86	592.9	10.42	S.G.D.
68.18	7.36	3.35	5.52	16.59	351.9	8.76	P.C.
62.50	6.37	7.65	7.63	16.62	871.7	11.85	S.G.D.
107.14	9.43	3.59	7.04	--	733.1	11.19	FAR.
71.43	7.43	3.48	5.78	--	390.1	9.07	FAR.
62.50	4.37	9.26	9.23	12.16	881.5	11.90	S.L.D.
88.24	8.29	3.65	4.27	5.54	883.3	11.90	P.C.

78.95	6.63	3.37	0.87	---	160.5	6.74	S.G.
88.24	5.29	3.35	2.57	16.48	142.0	6.47	S.G.D.
68.18	5.18	4.10	3.81	16.59	211.1	7.39	S.G.D.
71.43	5.29	4.15	3.99	---	209.3	7.37	S.G.
78.95	7.26	4.19	2.62	16.53	296.6	8.27	S.G.D.
93.75	9.37	3.36	4.69	6.38	682.2	10.92	P.C.
57.69	4.50	4.58	4.55	16.65	216.7	7.45	S.G.D.
51.72	4.34	4.52	4.50	16.68	202.0	7.28	S.G.D.
65.22	5.22	3.66	3.08	11.69	171.2	6.89	S.G.D.
65.22	6.13	5.48	5.27	16.61	445.9	9.48	S.G.D.
88.24	6.18	8.94	8.50	---	824.5	11.67	S.L.
68.18	5.45	4.02	3.58	16.22	215.2	7.43	S.G.D.
78.95	7.42	3.34	5.14	---	308.2	8.38	PAR.

3-D BED PROBE POSITION=(6CM,55CM)

SUPERFICIAL GAS VELOCITY=12.46CM/SEC PARTICLE SIZE:250-355

UB	AL	RF	RR	RW	VB	DE	SHAPE
93.75	10.50	5.46	2.10	--	679.2	10.91	S.G.
93.75	8.25	3.36	5.87	16.45	445.9	9.48	P.C.
83.33	7.00	3.42	5.78	16.51	366.9	8.88	P.C.
75.00	10.05	3.34	6.32	16.55	628.7	10.63	P.C.
78.95	6.79	3.37	5.41	16.53	311.6	8.41	P.C.
51.72	5.17	6.78	6.59	--	424.8	9.35	S.L.
88.24	7.94	3.39	5.58	--	388.6	9.05	PAR.
78.95	8.84	3.41	6.00	--	500.0	9.85	PAR.
60.00	5.28	12.67	10.29	--	955.3	12.25	S.L.
71.43	6.00	6.79	6.76	16.57	644.5	10.72	S.G.D.
78.95	6.95	7.64	7.61	--	808.0	11.59	S.L.
75.00	5.40	5.01	4.63	7.80	353.7	8.77	S.G.D.
60.00	5.28	4.13	3.96	--	207.2	7.34	S.G.
83.33	7.67	4.02	1.71	--	271.3	8.03	S.G.
83.33	7.17	3.42	5.46	--	335.1	8.62	PAR.
75.00	7.65	7.80	7.61	16.55	1142.1	12.97	S.G.D.
71.43	5.71	4.15	3.84	--	229.9	7.60	S.G.
51.72	4.97	4.11	4.02	--	190.3	7.14	S.G.
42.86	4.63	5.46	5.46	16.73	305.2	8.35	S.G.D.
88.24	8.12	3.44	5.87	--	439.9	9.44	PAR.
88.24	5.82	6.72	6.66	--	509.4	9.94	S.L.
107.14	6.86	5.68	5.29	16.38	543.6	10.13	S.G.D.
62.50	6.50	3.48	1.58	16.62	174.5	6.93	S.G.D.
60.00	5.52	5.91	5.90	--	390.1	9.09	S.L.
75.00	7.20	6.37	6.06	16.55	719.5	11.12	S.G.D.
78.95	7.42	4.07	2.30	--	275.9	8.08	S.G.
60.00	5.04	4.13	4.02	--	195.2	7.20	S.G.
53.57	6.11	4.02	3.44	--	233.1	7.64	S.G.
93.75	12.37	3.40	7.04	--	962.2	12.25	PAR.
83.33	7.50	4.02	2.03	--	269.5	8.01	S.G.
65.22	6.26	3.49	1.85	8.87	174.7	6.94	S.G.D.
71.43	3.57	6.79	5.98	--	224.3	7.56	S.L.
65.22	5.22	3.49	2.88	16.25	153.8	6.65	S.G.D.
88.24	6.35	6.72	6.71	--	583.9	10.40	S.L.
65.22	5.48	3.41	2.71	--	149.4	6.58	S.G.
60.00	6.00	4.06	3.56	--	232.7	7.63	S.G.
78.95	8.05	3.65	6.77	--	580.6	10.35	PAR.
107.14	9.00	3.59	6.87	--	668.0	10.85	PAR.
78.95	8.84	3.34	5.61	--	437.5	9.42	PAR.

78.95	5.37	4.97	4.58	7.64	346.4	8.71	S.G.D.
78.95	12.32	3.81	4.99	16.53	480.8	9.72	P.C.
65.22	8.87	3.41	6.00	--	501.6	9.86	PAR.
100.00	10.40	3.33	5.25	--	449.7	9.51	PAR.
83.33	9.67	4.57	10.04	16.51	1510.6	14.24	P.C.
83.33	8.17	4.02	7.79	16.51	775.2	11.40	P.C.
88.24	6.00	3.65	2.36	6.72	191.5	7.15	S.G.D.
46.87	3.84	16.45	16.42	16.71	3091.6	18.07	S.G.D.
83.33	7.67	3.32	5.09	--	311.6	8.41	PAR.
51.72	3.72	5.02	4.85	--	164.7	6.82	S.L.
78.95	6.63	3.30	4.46	--	207.2	7.34	PAR.
83.33	8.50	3.54	8.04	9.26	810.0	11.57	P.C.
78.95	8.68	3.41	6.37	16.53	552.1	10.18	P.C.
57.69	4.62	8.10	7.97	16.65	609.4	10.52	S.L.D.
88.24	5.82	6.72	6.66	--	509.4	9.94	S.L.
71.43	6.43	3.59	2.20	--	187.9	7.11	S.G.
44.12	4.85	6.07	6.07	16.72	392.7	9.09	S.L.D.
75.00	7.35	3.30	5.07	16.55	296.7	8.28	P.C.
78.95	8.05	6.33	6.10	--	743.7	11.24	S.G.
75.00	5.55	4.11	3.67	16.55	228.1	7.58	S.G.D.
60.00	7.20	6.78	6.77	--	713.7	11.09	S.G.
42.86	3.86	10.71	10.15	16.73	805.0	11.54	S.L.D.
71.43	5.00	4.59	4.47	16.57	249.5	7.81	S.G.D.
68.18	5.73	3.42	2.53	--	155.8	6.68	S.G.
62.50	4.37	5.88	5.69	--	266.0	8.00	S.L.
78.95	9.79	4.97	1.19	--	513.1	9.93	S.G.
78.95	10.11	5.45	2.84	--	668.6	10.85	S.G.
88.24	8.12	3.50	6.64	16.48	561.1	10.23	P.C.
50.00	4.10	5.49	5.31	--	217.9	7.49	S.L.
88.24	5.47	6.72	6.60	--	460.6	9.61	S.L.
53.57	5.36	5.68	5.67	--	350.9	8.77	S.L.
71.43	4.86	5.05	5.01	15.86	286.6	8.18	S.G.D.
107.14	10.50	3.31	5.82	--	559.5	10.22	PAR.
57.69	4.73	5.47	5.42	--	273.9	8.08	S.L.
62.50	7.00	5.88	5.77	--	546.3	10.14	S.G.
100.00	9.20	7.80	7.67	--	1258.4	13.39	S.G.
68.18	6.14	3.51	2.09	11.18	175.1	6.94	S.G.D.
71.43	7.14	4.59	3.81	--	353.6	8.77	S.G.
55.56	1.78	10.33	8.04	16.66	205.6	7.32	S.L.D.
48.39	3.39	6.98	6.97	8.09	434.8	9.40	S.G.D.
71.43	3.57	8.49	8.46	10.71	603.9	10.49	S.L.D.
62.50	6.50	3.48	1.49	9.26	174.7	6.94	S.G.D.
88.24	5.12	6.72	6.72	16.48	508.6	9.90	S.L.D.
65.22	3.91	5.48	5.45	16.25	241.7	7.73	S.L.D.
68.18	5.59	5.94	5.46	6.94	546.6	10.14	S.G.D.
44.12	2.74	16.72	9.17	--	371.6	8.94	S.L.
100.00	7.60	3.37	5.34	--	340.2	8.66	PAR.
65.22	5.09	7.24	7.10	8.87	717.2	11.11	S.G.D.

78.95	5.68	5.45	5.34	16.53	402.4	9.16	S.G.D.
107.14	5.79	7.33	7.16	--	567.5	10.30	S.L.
60.00	5.16	4.55	4.51	--	236.6	7.67	S.G.
55.56	4.00	10.33	10.17	13.65	927.8	12.10	S.L.D.
88.24	8.12	3.50	3.54	4.07	708.4	11.06	F.C.
60.00	4.44	5.91	5.90	16.63	330.4	8.58	S.L.D.
107.14	11.79	3.43	5.24	--	509.1	9.91	FAR.
75.00	4.80	5.49	5.49	16.55	325.4	8.53	S.G.D.
83.33	6.33	4.57	4.22	--	309.9	8.40	S.G.
53.57	2.68	4.56	4.16	--	82.7	5.42	S.L.
88.24	7.06	5.00	4.26	16.48	433.1	9.39	S.G.D.
57.69	6.23	4.02	3.37	--	237.6	7.68	S.G.
51.72	4.76	5.02	5.01	--	244.4	7.78	S.L.

3-D BED PROBE POSITION=(0CM,45CM)

SUPERFICIAL GAS VELOCITY=12.46CM/SEC PARTICLE SIZE:250-355

UB	AL	RF	RR	RW	VB	DE	SHAPE
88.24	10.41	3.44	7.16	16.48	835.0	11.68	P.C.
68.18	7.36	3.35	5.53	16.22	353.0	8.77	P.C.
53.57	2.68	4.99	4.42	---	92.4	5.62	S.L.
78.95	5.37	6.33	6.21	9.73	549.3	10.16	S.G.D.
75.00	6.75	3.37	5.35	16.55	303.4	8.34	P.C.
88.24	12.35	3.44	5.28	7.55	1304.8	13.56	P.C.
62.50	6.50	3.48	1.49	9.26	174.7	6.94	S.G.D.
71.43	6.43	4.15	3.22	15.86	266.3	7.98	S.G.D.
78.95	4.26	9.73	9.39	16.53	771.8	11.38	S.L.D.
71.43	5.71	4.15	3.84	---	229.9	7.60	S.G.
75.00	7.95	3.45	6.27	16.55	490.6	9.79	P.C.
71.43	10.14	3.53	4.86	16.57	376.1	8.96	P.C.
65.22	5.22	4.10	3.49	6.34	227.5	7.57	S.G.D.
75.00	4.65	6.37	6.37	15.14	410.8	9.22	S.L.D.
88.24	10.24	3.44	7.28	12.92	847.1	11.74	P.C.
83.33	8.67	4.12	8.67	16.51	1014.5	12.47	P.C.
68.18	6.68	4.10	3.19	---	262.8	7.95	S.G.
93.75	8.06	8.27	8.05	16.45	1366.6	13.77	S.G.D.
62.50	6.50	3.48	1.58	16.62	174.5	6.93	S.G.D.
88.24	7.76	8.94	8.83	16.48	1519.2	14.26	S.G.D.
83.33	11.17	3.48	6.13	9.26	1142.2	12.97	P.C.
88.24	9.00	8.94	8.94	---	1511.2	14.24	S.G.
83.33	8.50	4.12	8.58	16.51	975.5	12.30	P.C.
83.33	7.83	3.48	6.41	16.51	504.3	9.88	P.C.
65.22	3.91	5.48	5.45	16.25	241.7	7.73	S.L.D.
78.95	5.53	6.33	6.32	16.53	508.9	9.91	S.G.D.
68.18	4.09	5.19	5.19	16.59	234.9	7.66	S.L.D.
78.95	10.42	3.52	7.04	---	810.3	11.57	PAR.
68.18	6.55	3.46	1.58	---	172.4	6.91	S.G.
88.24	12.71	3.44	7.35	---	1077.8	12.72	PAR.
71.43	4.71	6.79	6.76	16.57	458.9	9.57	S.L.D.
78.95	9.00	3.34	6.07	14.37	519.7	9.98	P.C.
68.18	5.18	4.10	3.46	5.94	227.6	7.58	S.G.D.
78.95	5.37	6.33	6.33	16.53	489.1	9.78	S.G.D.
75.00	6.75	3.45	0.88	15.14	171.1	6.89	S.G.D.
75.00	7.95	3.45	6.33	15.14	498.2	9.84	P.C.
53.57	2.46	4.99	4.63	16.67	98.7	5.73	S.L.D.
78.95	8.68	3.41	6.37	16.53	552.1	10.18	P.C.
68.18	4.91	5.94	5.93	16.22	385.8	9.03	S.G.D.
93.75	7.87	8.27	7.27	8.27	1565.0	14.40	S.G.D.

75.00	7.80	3.45	6.26	15.14	479.5	9.71	P.C.
68.18	3.95	5.19	5.18	16.59	223.4	7.53	S.L.D.
88.24	12.35	3.44	8.02	12.92	1237.6	13.32	P.C.
68.18	5.73	3.62	2.95	--	176.8	6.96	S.G.
78.95	4.26	9.73	9.39	16.53	771.8	11.38	S.L.D.
71.43	6.29	5.05	4.67	16.57	391.8	9.08	S.G.D.
78.95	8.53	3.52	6.36	--	542.4	10.12	PAR.
88.24	10.24	3.44	7.09	16.48	806.9	11.55	P.C.
93.75	9.56	8.27	8.17	--	1460.6	14.08	S.G.
57.69	5.19	3.49	3.05	--	149.2	6.58	S.G.
71.43	9.14	3.39	6.00	--	517.0	9.96	PAR.
71.43	4.86	5.68	5.62	--	300.8	8.34	S.L.
78.95	4.74	9.73	8.35	--	574.3	10.34	S.L.
62.50	6.25	3.40	1.67	12.16	162.4	6.77	S.G.D.
83.33	7.83	3.42	5.11	7.22	554.4	10.19	P.C.
60.00	5.28	4.13	3.81	16.63	218.1	7.47	S.G.D.
83.33	8.50	3.54	8.04	9.26	810.0	11.57	P.C.
71.43	5.00	5.68	5.67	16.57	364.9	8.87	S.G.D.
78.95	8.84	3.41	6.00	--	500.0	9.85	PAR.
68.18	3.95	5.19	5.18	16.59	223.4	7.53	S.L.D.
83.33	9.00	3.48	6.87	16.51	666.2	10.84	P.C.
75.00	7.50	3.30	4.85	16.55	276.7	8.08	P.C.
78.95	7.58	3.58	6.97	14.37	575.8	10.32	P.C.
65.22	5.61	4.06	3.49	11.69	228.3	7.58	S.G.D.
78.95	4.26	9.73	9.39	16.53	771.8	11.38	S.L.D.
68.18	7.36	3.35	5.52	16.59	351.9	8.76	P.C.
78.95	9.63	3.37	6.45	16.53	627.8	10.62	P.C.
88.24	9.71	3.57	7.04	--	754.7	11.30	PAR.
71.43	7.29	3.36	5.20	--	309.0	8.39	PAR.
62.50	4.62	3.52	3.35	--	133.2	6.34	S.G.
78.95	8.05	6.33	5.71	16.53	803.2	11.53	S.G.D.
71.43	4.71	5.68	5.68	15.86	338.4	8.65	S.G.D.
93.75	5.62	12.16	12.10	16.45	1897.8	15.36	S.L.D.
71.43	10.29	3.53	4.73	--	361.0	8.83	PAR.
75.00	6.15	3.55	2.23	15.14	180.1	7.01	S.G.D.
65.22	5.22	4.10	3.49	6.34	227.5	7.57	S.G.D.
78.95	4.74	5.45	5.41	--	273.0	8.07	S.L.
71.43	4.71	5.68	5.60	--	286.7	8.20	S.L.
75.00	7.20	3.55	6.89	16.55	535.0	10.07	P.C.
57.69	4.38	4.09	4.08	--	158.7	6.72	S.G.
78.95	5.37	6.33	6.21	9.73	549.3	10.16	S.G.D.
68.18	6.55	4.02	2.91	16.59	252.1	7.84	S.G.D.
88.24	9.18	3.44	6.24	--	562.2	10.24	PAR.
65.22	4.83	4.84	4.73	11.69	272.8	8.05	S.G.D.
68.18	5.73	3.62	2.95	--	176.8	6.96	S.G.
78.95	9.63	3.34	6.22	16.53	583.6	10.37	P.C.

83.33	9.83	3.38	6.68	13.65	687.2	10.95	F.C.
78.95	4.74	6.33	6.13	--	335.3	8.64	S.L.
68.18	4.50	6.94	6.87	16.59	444.8	9.47	S.L.D.
83.33	7.83	3.48	7.07	9.26	597.2	10.45	F.C.
62.50	6.00	3.52	2.16	7.65	175.5	6.95	S.G.D.
78.95	9.00	3.34	5.66	--	453.3	9.53	PAR.
68.18	6.14	4.02	3.21	16.59	240.0	7.71	S.G.D.
65.22	4.83	4.84	4.19	4.84	325.0	8.53	S.G.D.
78.95	9.79	4.97	1.19	--	513.1	9.93	S.G.
78.95	4.89	9.73	9.56	16.53	950.2	12.20	S.L.D.
60.00	6.96	3.55	1.02	--	187.8	7.11	S.G.
71.43	6.29	4.59	4.02	15.86	324.0	8.52	S.G.D.
78.95	4.89	9.73	9.66	14.37	1027.4	12.52	S.L.D.
88.24	8.12	3.50	3.54	4.07	708.4	11.06	F.C.

3-D BED PROBE POSITION=(2CM,45CM)

SUPERFICIAL GAS VELOCITY=12.46CM/SEC PARTICLE SIZE:250-355

UB	AL	RF	RR	RW	VB	DE	SHAPE
83.33	8.00	3.38	5.55	---	387.8	9.05	FAR.
71.43	4.86	5.68	5.62	---	300.8	8.34	S.L.
62.50	6.75	7.65	7.60	---	773.3	11.42	S.L.
71.43	10.43	4.15	3.15	3.30	1742.7	14.93	P.C.
68.18	6.00	3.46	2.36	---	165.5	6.81	S.G.
62.50	6.12	4.56	4.06	16.28	312.1	8.42	S.G.D.
65.22	7.17	5.48	5.21	---	499.7	9.85	S.G.
55.56	4.44	4.61	4.58	16.66	215.5	7.44	S.G.D.
78.95	7.58	3.58	6.27	---	467.5	9.63	FAR.
68.18	2.32	6.94	5.99	16.59	151.2	6.61	S.L.D.
75.00	11.40	3.55	5.40	7.80	1341.8	13.68	P.C.
71.43	10.29	4.15	3.15	3.30	1702.9	14.82	P.C.
65.22	4.17	7.24	7.21	8.87	570.0	10.29	S.G.D.
65.22	5.61	4.06	3.75	---	216.5	7.45	S.G.
65.22	5.48	3.49	2.57	8.87	162.2	6.77	S.G.D.
78.95	5.68	3.52	2.60	16.53	167.1	6.83	S.G.D.
83.33	6.83	3.61	1.49	16.51	195.9	7.21	S.G.D.
46.87	3.66	4.54	4.45	---	139.3	6.45	S.L.
53.57	4.29	10.71	10.35	16.38	960.7	12.24	S.L.D.
83.33	2.33	4.57	4.25	16.51	78.8	5.32	S.L.D.
53.57	2.68	4.56	4.16	---	82.7	5.42	S.L.
62.50	5.00	9.26	8.22	---	596.0	10.47	S.L.
40.54	5.03	5.50	5.48	---	303.6	8.36	S.L.
57.69	5.77	6.32	6.29	---	459.4	9.60	S.L.
71.43	5.57	4.06	3.77	---	215.2	7.44	S.G.
68.18	6.68	4.02	2.80	16.59	255.6	7.87	S.G.D.
53.57	3.21	16.67	16.59	16.67	2797.5	17.48	S.G.D.
71.43	5.86	4.59	4.41	---	283.9	8.15	S.G.
60.00	4.92	5.91	5.83	---	325.1	8.55	S.L.
68.18	5.59	4.53	4.23	16.59	278.6	8.10	S.G.D.
44.12	3.79	6.72	6.53	16.72	323.2	8.51	S.L.D.
68.18	3.95	5.19	5.18	16.59	223.4	7.53	S.L.D.
75.00	6.75	4.11	2.89	15.14	270.4	8.02	S.G.D.
78.95	4.26	9.73	8.05	---	474.2	9.70	S.L.
60.00	5.40	4.06	3.83	---	206.8	7.34	S.G.
68.18	6.68	4.10	3.19	---	262.8	7.95	S.G.
78.95	7.74	3.58	6.33	---	487.2	9.76	FAR.
55.56	3.56	4.61	4.49	---	136.0	6.40	S.L.
78.95	4.74	4.07	4.01	---	175.5	6.95	S.G.
93.75	8.06	3.52	6.22	---	490.1	9.78	FAR.

50.00	5.30	6.80	6.27	6.80	731.9	11.18	S.G.D.
42.86	3.51	9.00	8.42	16.49	488.6	9.77	S.L.D.
71.43	4.71	5.68	5.60	--	286.7	8.20	S.L.
78.95	4.74	5.45	5.41	--	273.0	8.07	S.L.
78.95	5.37	9.73	9.65	16.53	1087.6	12.76	S.L.D.
83.33	7.33	7.22	7.22	--	807.0	11.55	S.G.
62.50	5.25	7.65	7.64	16.28	668.8	10.85	S.L.D.
71.43	7.29	5.68	3.80	4.06	663.5	10.82	S.G.D.
75.00	6.75	4.11	2.91	16.55	270.0	8.02	S.G.D.
68.18	4.64	5.94	5.79	--	296.4	8.30	S.L.
57.69	4.04	9.98	8.02	--	442.5	9.48	S.L.
57.69	3.58	8.10	7.65	16.65	409.6	9.21	S.L.D.
88.24	8.82	3.30	5.40	16.48	404.4	9.17	P.C.
78.95	8.53	3.52	6.36	--	542.4	10.12	PAR.
107.14	11.14	7.33	5.55	16.38	1468.0	14.10	S.G.D.
55.56	5.44	3.61	2.94	16.66	171.3	6.89	S.G.D.
68.18	5.59	4.02	3.52	16.22	220.6	7.50	S.G.D.
71.43	6.29	4.59	4.26	--	309.3	8.39	S.G.
107.14	9.00	3.33	5.16	7.33	586.7	10.39	P.C.
48.39	2.90	6.20	5.25	--	138.6	6.44	S.L.
71.43	7.29	3.48	5.73	--	375.2	8.95	PAR.
75.00	6.15	3.55	2.23	15.14	180.1	7.01	S.G.D.
51.72	4.76	14.63	10.80	--	927.6	12.13	S.L.
48.39	4.06	11.82	8.92	--	542.9	10.15	S.L.
68.18	6.41	4.98	4.77	--	366.7	8.88	S.G.
60.00	6.96	3.55	1.02	--	187.8	7.11	S.G.
78.95	8.21	3.46	6.46	16.53	537.5	10.09	P.C.
65.22	5.87	5.48	5.47	--	381.5	9.00	S.G.
53.57	2.68	4.99	4.42	--	92.4	5.62	S.L.
93.75	9.56	3.33	5.27	16.45	417.5	9.27	P.C.
60.00	3.60	12.67	12.05	16.63	1102.5	12.82	S.L.D.
75.00	7.65	7.80	7.61	16.55	1142.1	12.97	S.G.D.
88.24	12.71	3.57	8.05	--	1293.3	13.52	PAR.
83.33	6.33	4.02	3.03	13.65	247.0	7.78	S.G.D.
65.22	7.70	3.60	6.39	--	493.8	9.81	PAR.
65.22	5.09	16.25	16.17	16.61	3988.8	19.68	S.G.D.
65.22	5.22	4.10	3.49	6.34	227.5	7.57	S.G.D.
75.00	7.05	3.55	0.58	15.14	188.0	7.11	S.G.D.
68.18	6.95	4.10	2.61	11.18	275.1	8.07	S.G.D.
75.00	4.65	6.37	6.22	7.80	511.2	9.92	S.G.D.
100.00	11.80	3.30	5.95	--	656.2	10.78	PAR.
78.95	8.84	3.34	5.61	--	437.5	9.42	PAR.
68.18	6.68	4.10	3.19	--	262.8	7.95	S.G.
57.69	2.31	13.14	11.65	16.65	619.9	10.58	S.L.D.
71.43	5.14	3.39	2.91	--	139.4	6.43	S.G.
57.69	5.65	8.10	7.72	--	624.0	10.63	S.L.
78.95	7.42	3.46	5.32	7.64	530.6	10.04	P.C.
55.56	6.78	3.61	1.74	--	195.1	7.20	S.G.

93.75	10.69	5.46	1.38	16.45	681.4	10.92	S.G.D.
100.00	7.00	3.42	5.35	--	314.9	8.44	PAR.
75.00	9.30	5.01	2.59	--	518.8	9.97	S.G.
57.69	3.46	6.85	6.54	16.65	288.9	8.20	S.L.D.
93.75	9.37	3.36	5.88	--	509.8	9.91	PAR.
53.57	5.57	4.15	3.89	--	223.2	7.53	S.G.
78.95	9.00	3.34	5.66	--	453.3	9.53	PAR.
71.43	5.00	5.05	4.83	8.49	325.9	8.54	S.G.D.
78.95	7.58	3.58	6.27	--	467.5	9.63	PAR.
83.33	9.50	3.38	6.46	16.51	621.4	10.59	P.C.
78.95	5.05	9.73	8.53	--	645.0	10.75	S.L.
68.18	4.50	4.53	4.53	--	192.8	7.19	S.L.

3-D BED PROBE POSITION=(4CM,45CM)

SUPERFICIAL GAS VELOCITY=12.46CM/SEC PARTICLE SIZE:250-355

UB	AL	RF	RR	RW	VB	DE	SHAPE
62.50	6.50	3.48	1.54	12.16	174.6	6.93	S.G.D.
100.00	12.80	3.64	5.12	---	526.4	10.02	PAR.
78.95	7.74	3.58	6.33	---	487.2	9.76	PAR.
88.24	10.41	3.44	7.16	16.48	835.0	11.68	P.C.
83.33	9.17	7.22	6.45	16.51	1199.2	13.18	S.G.D.
83.33	10.33	3.54	7.12	---	823.4	11.63	PAR.
57.69	3.46	6.32	5.63	---	194.3	7.21	S.L.
65.22	6.26	3.49	1.97	16.25	174.1	6.93	S.G.D.
57.69	6.46	3.58	2.13	---	187.5	7.10	S.G.
50.00	4.00	11.43	8.69	---	507.7	9.92	S.L.
78.95	11.53	3.30	6.04	---	660.9	10.81	PAR.
65.22	5.35	4.06	3.85	---	204.7	7.31	S.G.
44.12	2.74	8.94	7.92	16.24	322.9	8.51	S.L.D.
65.22	8.74	3.49	6.34	---	551.8	10.18	PAR.
38.46	4.31	8.61	8.59	11.90	739.0	11.22	S.L.D.
55.56	5.78	4.00	3.58	---	217.1	7.46	S.G.
65.22	4.70	4.84	4.83	---	226.5	7.58	S.L.
71.43	13.00	3.59	8.26	---	1393.7	13.86	PAR.
75.00	6.45	3.55	2.06	---	183.4	7.05	S.G.
55.56	1.56	13.65	11.47	16.35	395.2	9.10	S.L.D.
71.43	7.14	3.59	0.52	---	193.8	7.18	S.G.
100.00	8.60	3.33	5.78	16.41	450.7	9.51	P.C.
65.22	5.35	4.57	4.50	---	250.1	7.82	S.G.
78.95	8.68	3.41	5.95	---	482.3	9.73	PAR.
71.43	8.29	3.48	6.59	16.57	564.0	10.25	P.C.
65.22	6.00	3.41	2.06	16.61	160.5	6.74	S.G.D.
68.18	6.68	4.02	2.80	16.59	255.6	7.87	S.G.D.
71.43	5.00	4.59	4.47	16.57	249.5	7.81	S.G.D.
53.57	3.86	4.08	4.08	---	130.8	6.32	S.L.
83.33	8.50	4.12	8.58	16.51	975.5	12.30	P.C.
65.22	7.57	3.35	4.40	---	229.7	7.60	PAR.
65.22	5.87	3.45	2.29	16.61	163.1	6.78	S.G.D.
55.56	2.44	10.33	6.67	---	178.5	7.01	S.L.
83.33	8.83	3.42	6.06	---	509.1	9.91	PAR.
71.43	6.00	4.06	2.76	4.15	254.5	7.86	S.G.D.
75.00	7.20	3.55	6.89	16.55	535.0	10.07	P.C.
78.95	8.84	3.34	5.61	---	437.5	9.42	PAR.
46.87	3.19	8.27	7.64	16.19	358.2	8.81	S.L.D.
88.24	9.71	3.57	7.04	---	754.7	11.30	PAR.
88.24	8.12	3.35	5.78	16.48	425.1	9.33	P.C.

88.24	12.71	3.44	7.35	--	1077.8	12.72	FAR.
68.18	6.00	3.31	1.94	--	148.6	6.57	S.G.
78.95	7.58	3.58	6.85	16.53	557.6	10.21	F.C.
93.75	6.94	3.46	5.50	--	329.9	8.57	FAR.
75.00	7.95	3.45	6.33	15.14	498.2	9.84	F.C.
75.00	4.50	6.37	6.25	7.80	492.9	9.80	S.G.D.
93.75	5.25	16.45	12.05	--	1272.8	13.48	S.L.
71.43	8.14	3.48	7.61	8.49	685.3	10.94	F.C.
68.18	5.73	3.42	2.53	--	155.8	6.68	S.G.
93.75	7.50	8.27	8.15	16.45	1250.5	13.37	S.G.D.
51.72	5.17	3.62	3.26	--	159.0	6.72	S.G.
93.75	9.56	3.52	4.23	5.46	948.7	12.19	F.C.
100.00	4.60	7.80	7.11	--	416.5	9.29	S.L.
93.75	5.62	12.16	10.25	--	1022.2	12.53	S.L.
48.39	3.87	6.20	6.20	9.55	349.7	8.74	S.L.D.
71.43	4.71	5.68	5.60	--	286.7	8.20	S.L.
78.95	7.11	3.37	5.60	14.37	348.7	8.73	F.C.
44.12	3.79	5.54	5.26	--	193.6	7.20	S.L.
68.18	6.00	3.46	2.36	--	165.5	6.81	S.G.
46.87	2.44	4.88	4.53	16.45	93.8	5.64	S.L.D.
78.95	8.21	3.30	4.84	--	301.8	8.32	FAR.
78.95	5.21	6.33	6.33	16.53	469.2	9.64	S.G.D.
65.22	4.96	4.10	3.88	16.25	200.9	7.27	S.G.D.
62.50	5.25	3.57	3.16	--	158.0	6.71	S.G.
78.95	8.21	3.46	6.46	16.53	537.5	10.09	F.C.
68.18	3.95	5.19	5.18	16.59	223.4	7.53	S.L.D.
60.00	3.96	3.43	3.32	16.63	109.8	5.94	S.G.D.
71.43	4.57	5.68	5.57	--	272.7	8.07	S.L.
65.22	2.48	16.61	8.73	--	304.5	8.37	S.L.
53.57	6.43	4.99	4.78	--	370.0	8.91	S.G.
100.00	11.80	3.30	5.95	--	656.2	10.78	FAR.
83.33	8.00	3.32	4.65	--	271.4	8.03	FAR.
75.00	7.05	3.55	0.58	15.14	188.0	7.11	S.G.D.
68.18	6.95	4.10	2.61	11.18	275.1	8.07	S.G.D.
53.57	2.68	4.56	4.16	--	82.7	5.42	S.L.
53.57	4.82	6.37	6.18	--	348.2	8.75	S.L.
68.18	6.68	4.10	3.19	--	262.8	7.95	S.G.
65.22	9.00	3.49	6.96	16.61	682.8	10.93	F.C.
78.95	8.84	3.34	5.61	--	437.5	9.42	FAR.
71.43	4.71	5.68	5.60	--	286.7	8.20	S.L.
78.95	7.42	3.46	5.32	7.64	530.6	10.04	F.C.
55.56	6.78	3.61	1.74	--	195.1	7.20	S.G.
93.75	10.69	5.46	1.38	16.45	681.4	10.92	S.G.D.
65.22	6.26	3.49	1.97	16.25	174.1	6.93	S.G.D.
75.00	4.65	6.37	6.37	15.14	410.8	9.22	S.L.D.
57.69	3.46	6.85	6.54	16.65	288.9	8.20	S.L.D.
93.75	9.37	3.36	5.88	--	509.8	9.91	FAR.
53.57	5.57	4.15	3.89	--	223.2	7.53	S.G.

75.00	7.35	4.55	2.59	4.02	375.0	8.95	S.G.D.
71.43	5.00	5.05	4.83	8.49	325.9	8.54	S.G.D.
68.18	4.64	5.94	5.79	--	296.4	8.30	S.L.
71.43	7.29	3.36	5.20	--	309.0	8.39	PAR.
78.95	8.68	3.41	5.95	--	482.3	9.73	PAR.
100.00	11.40	3.33	6.66	16.41	792.7	11.48	P.C.
55.56	1.56	13.65	11.47	16.35	395.2	9.10	S.L.D.
75.00	4.50	6.37	6.25	7.80	492.9	9.80	S.G.D.
115.38	4.85	6.85	6.41	6.85	684.7	10.94	S.G.D.
78.95	7.74	3.58	6.33	--	487.2	9.76	PAR.
75.00	11.40	3.55	5.40	7.80	1341.8	13.68	P.C.
75.00	4.65	6.37	6.22	7.80	511.2	9.92	S.G.D.

3-D BED PROBE POSITION=(6CM,45CM)

SUPERFICIAL GAS VELOCITY=12.46CM/SEC PARTICLE SIZE:250-355

UB	AL	RF	RR	RW	VB	DE	SHAPE
71.43	4.71	5.68	5.60	---	286.7	8.20	S.L.
75.00	4.65	6.37	6.22	7.80	511.2	9.92	S.G.D.
88.24	9.71	3.35	6.86	8.94	699.9	11.02	P.C.
75.00	7.50	3.30	4.85	16.55	276.7	8.08	P.C.
57.69	5.31	13.14	12.87	13.14	2838.8	17.57	S.G.D.
78.95	8.84	3.34	5.61	---	437.5	9.42	PAR.
53.57	2.68	4.56	4.16	---	82.7	5.42	S.L.
65.22	4.83	4.84	4.84	---	236.1	7.69	S.L.
75.00	4.65	6.37	6.37	15.14	410.8	9.22	S.L.D.
78.95	6.63	3.41	1.13	---	166.0	6.82	S.G.
75.00	6.00	3.55	2.58	---	175.6	6.95	S.G.
78.95	5.21	6.33	6.33	16.53	469.2	9.64	S.G.D.
57.69	4.85	4.09	3.90	16.65	194.2	7.19	S.G.D.
60.00	4.08	4.06	4.06	---	141.1	6.46	S.G.
71.43	6.43	4.59	3.96	16.57	330.6	8.58	S.G.D.
88.24	7.41	3.57	6.15	---	440.1	9.44	PAR.
40.54	3.16	4.54	4.47	16.74	127.3	6.24	S.L.D.
71.43	6.43	3.66	2.20	16.57	197.6	7.23	S.G.D.
65.22	3.52	3.60	3.60	---	94.5	5.67	S.L.
83.33	8.00	4.02	0.63	---	273.1	8.05	S.G.
71.43	5.86	3.66	2.72	15.86	186.7	7.09	S.G.D.
53.57	3.75	14.16	9.60	---	570.2	10.32	S.L.
62.50	5.00	4.56	4.44	16.62	247.1	7.79	S.G.D.
88.24	7.41	3.39	5.76	16.48	385.4	9.03	P.C.
44.12	4.68	4.07	3.93	16.72	184.7	7.07	S.G.D.
71.43	7.71	5.05	3.95	16.57	476.7	9.69	S.G.D.
88.24	4.59	5.54	5.46	---	265.6	8.00	S.L.
55.56	3.67	5.05	4.86	---	161.6	6.78	S.L.
68.18	6.55	4.10	3.06	16.59	263.1	7.95	S.G.D.
50.00	4.70	6.80	6.77	16.69	457.9	9.56	S.L.D.
78.95	4.74	5.45	5.41	---	273.0	8.07	S.L.
53.57	4.07	4.99	4.98	10.71	235.9	7.67	S.G.D.
57.69	4.96	3.63	3.24	16.65	158.9	6.72	S.G.D.
60.00	6.96	3.55	1.02	---	187.8	7.11	S.G.
78.95	7.74	3.58	6.33	---	487.2	9.76	PAR.
78.95	6.32	9.73	9.11	---	955.1	12.25	S.L.
107.14	13.07	3.33	7.18	16.38	1056.1	12.63	P.C.
68.18	6.68	3.62	1.79	16.59	196.6	7.21	S.G.D.
75.00	6.75	4.11	2.91	16.55	270.0	8.02	S.G.D.
93.75	11.44	3.46	7.06	---	896.7	11.96	PAR.

50.00	4.30	6.80	6.33	---	312.0	8.44	S.L.
75.00	4.35	4.11	4.10	---	158.0	6.71	S.G.
68.18	4.50	4.53	4.53	---	192.8	7.19	S.L.
71.43	5.29	4.15	3.73	10.71	226.0	7.56	S.G.D.
71.43	5.57	3.59	2.99	---	169.0	6.86	S.G.
60.00	3.72	6.78	6.68	12.67	350.6	8.75	S.L.D.
62.50	5.50	5.88	5.84	16.62	442.2	9.45	S.G.D.
83.33	6.33	4.12	3.07	9.26	262.9	7.95	S.G.D.
34.88	3.35	4.01	3.95	---	101.8	5.81	S.L.
83.33	10.50	3.32	5.56	16.51	510.1	9.91	P.C.
71.43	6.43	4.59	4.20	---	317.3	8.46	S.G.
65.22	5.87	4.84	4.54	16.61	333.7	8.61	S.G.D.
71.43	7.29	3.39	5.36	---	328.3	8.56	PAR.
75.00	6.30	3.55	2.09	16.55	182.4	7.04	S.G.D.
68.18	5.05	4.02	3.89	---	187.4	7.10	S.G.
75.00	6.45	3.32	1.09	---	152.5	6.63	S.G.
50.00	4.30	4.14	4.13	---	157.1	6.69	S.G.
88.24	6.18	3.65	2.39	12.92	192.8	7.17	S.G.D.
88.24	9.18	3.32	4.96	---	355.0	8.79	PAR.
53.57	2.79	4.99	4.76	16.38	121.4	6.14	S.L.D.
68.18	5.86	3.62	2.67	16.59	183.2	7.05	S.G.D.
68.18	5.45	3.38	2.68	---	146.4	6.54	S.G.
78.95	5.53	6.33	6.28	---	431.1	9.40	S.L.
68.18	4.50	4.10	4.08	---	165.5	6.81	S.G.
53.57	2.68	4.99	4.42	---	92.4	5.62	S.L.
68.18	3.95	5.19	5.18	16.59	223.4	7.53	S.L.D.
71.43	5.57	4.06	3.77	---	215.2	7.44	S.G.
57.69	5.08	13.14	13.01	16.65	1986.2	15.60	S.L.D.
53.57	3.54	16.38	10.16	---	596.8	10.47	S.L.
68.18	4.50	6.94	6.87	16.59	444.8	9.47	S.L.D.
65.22	7.17	3.49	5.74	---	371.9	8.92	PAR.
78.95	7.58	3.58	6.27	---	467.5	9.63	PAR.
65.22	3.91	4.10	3.93	6.34	170.5	6.88	S.G.D.
78.95	5.37	9.73	8.70	---	718.6	11.14	S.L.
51.72	4.55	6.78	6.40	---	342.4	8.70	S.L.
88.24	7.76	3.39	4.34	---	230.0	7.60	PAR.
88.24	7.59	5.54	4.71	12.92	582.5	10.36	S.G.D.
53.57	4.39	6.37	6.33	16.67	369.8	8.91	S.L.D.
65.22	3.52	3.60	3.60	---	94.5	5.67	S.L.
71.43	5.43	3.53	2.72	10.71	164.3	6.80	S.G.D.
65.22	4.04	7.24	6.49	---	302.5	8.35	S.L.
78.95	6.47	3.32	1.03	---	152.8	6.63	S.G.
83.33	7.83	3.48	6.41	16.51	504.3	9.88	P.C.
78.95	8.53	3.52	6.36	---	542.4	10.12	PAR.
62.50	5.25	4.02	3.67	16.28	206.7	7.34	S.G.D.
57.69	5.77	5.47	5.47	---	371.2	8.92	S.G.
62.50	5.25	3.52	3.07	---	153.6	6.65	S.G.
78.95	8.05	6.33	6.10	---	743.7	11.24	S.G.

75.00	8.70	4.02	7.22	--	713.4	11.09	PAR.
71.43	6.29	3.36	1.52	16.57	157.2	6.70	S.G.D.
55.56	1.78	10.33	5.79	--	96.6	5.71	S.L.
60.00	5.04	6.78	6.71	9.60	591.7	10.42	S.G.D.
88.24	8.47	3.57	4.27	5.54	818.1	11.60	P.C.
83.33	7.50	3.31	4.88	--	280.7	8.12	PAR.
65.22	4.57	7.24	7.24	11.69	552.6	10.18	S.L.D.
57.69	4.73	4.50	4.50	--	205.7	7.32	S.G.
57.69	4.85	6.85	6.85	13.14	516.2	9.95	S.L.D.
51.72	5.48	5.47	5.47	--	343.6	8.69	S.G.
55.56	3.56	4.61	4.59	16.66	156.4	6.68	S.L.D.
75.00	6.75	4.11	2.91	16.55	270.0	8.02	S.G.D.

3-D BED PROBE POSITION=(8CM,45CM)

SUPERFICIAL GAS VELOCITY=12.46CM/SEC PARTICLE SIZE:250-355

UB	AL	RF	RR	RW	VB	DE	SHAPE
57.69	4.04	3.63	3.61	--	117.2	6.07	S.G.
68.18	6.41	4.02	2.92	11.22	250.1	7.82	S.G.D.
60.00	6.96	3.55	1.02	--	187.8	7.11	S.G.
78.95	7.74	3.58	6.33	--	487.2	9.76	FAR.
83.33	7.67	3.48	6.47	13.65	501.5	9.86	F.C.
65.22	5.22	3.49	2.88	16.25	153.8	6.65	S.G.D.
78.95	8.53	3.41	6.39	14.37	544.9	10.13	F.C.
68.18	3.95	5.19	5.18	16.59	223.4	7.53	S.L.D.
78.95	8.84	3.34	6.02	14.37	501.6	9.86	F.C.
78.95	9.63	3.41	6.71	16.53	679.4	10.91	F.C.
53.57	2.68	4.99	4.42	--	92.4	5.62	S.L.
78.95	5.21	6.33	6.06	7.64	574.2	10.31	S.G.D.
62.50	4.62	3.57	3.30	16.62	142.7	6.48	S.G.D.
78.95	8.21	3.58	7.14	16.53	654.8	10.77	F.C.
65.22	5.87	3.60	2.54	11.69	181.1	7.02	S.G.D.
83.33	9.00	3.48	6.87	16.51	666.2	10.84	F.C.
65.22	4.57	4.06	4.03	--	166.2	6.82	S.G.
83.33	9.33	3.61	7.81	16.51	890.5	11.94	F.C.
68.18	4.09	5.19	5.19	16.22	235.7	7.66	S.L.D.
83.33	8.67	4.12	8.67	16.51	1014.5	12.47	F.C.
75.00	6.15	3.55	2.23	15.14	180.1	7.01	S.G.D.
88.24	12.71	3.44	7.35	--	1077.8	12.72	FAR.
78.95	8.84	3.34	5.61	--	437.5	9.42	FAR.
78.95	9.47	4.97	2.09	--	510.2	9.91	S.G.
68.18	6.68	4.02	2.80	16.59	255.6	7.87	S.G.D.
65.22	3.91	5.48	5.45	16.25	241.7	7.73	S.L.D.
62.50	6.00	3.52	2.16	7.65	175.5	6.95	S.G.D.
78.95	8.68	3.41	6.37	16.53	552.1	10.18	F.C.
75.00	6.75	3.55	1.41	15.14	186.9	7.09	S.G.D.
65.22	5.61	4.06	3.75	--	216.5	7.45	S.G.
88.24	9.00	3.44	6.65	16.48	623.5	10.60	F.C.
53.57	2.57	4.99	4.68	16.38	106.4	5.88	S.L.D.
78.95	4.89	9.73	9.56	16.53	950.2	12.20	S.L.D.
75.00	4.65	6.37	6.37	15.14	410.8	9.22	S.L.D.
71.43	7.00	3.66	1.34	16.57	203.6	7.30	S.G.D.
78.95	7.42	3.58	5.32	7.64	645.5	10.72	F.C.
53.57	2.89	4.99	4.79	16.67	128.6	6.26	S.L.D.
65.22	5.61	4.06	3.56	16.25	225.3	7.55	S.G.D.
68.18	6.68	4.10	3.19	--	262.8	7.95	S.G.
62.50	5.75	3.52	2.38	7.65	171.4	6.89	S.G.D.
65.22	5.22	4.10	3.49	6.34	227.5	7.57	S.G.D.

83.33	9.00	3.48	7.02	13.65	692.3	10.98	F.C.
68.18	6.14	3.51	2.33	---	173.4	6.92	S.G.
78.95	7.11	3.58	0.49	5.45	192.3	7.16	S.G.D.
88.24	10.24	3.44	7.09	16.48	806.9	11.55	F.C.
57.69	5.19	3.54	2.97	16.65	157.0	6.69	S.G.D.
75.00	7.95	3.45	6.27	16.55	490.6	9.79	F.C.
83.33	9.33	3.61	7.81	16.51	890.5	11.94	F.C.
88.24	6.71	8.94	8.85	12.92	1359.3	13.74	S.G.D.
78.95	5.53	6.33	6.32	16.53	508.9	9.91	S.G.D.
62.50	6.12	3.33	1.66	16.28	151.8	6.62	S.G.D.
71.43	4.71	5.68	5.60	---	286.7	8.20	S.L.
71.43	7.00	3.43	5.84	15.86	374.0	8.94	F.C.
65.22	3.52	3.60	3.60	---	94.5	5.67	S.L.
65.22	4.83	6.34	5.86	6.34	580.4	10.35	S.G.D.
68.18	6.55	3.46	1.58	---	172.4	6.91	S.G.
68.18	4.23	5.19	5.10	---	212.4	7.42	S.L.
68.18	4.50	5.19	5.15	---	234.9	7.68	S.L.
75.00	6.75	3.45	0.88	15.14	171.1	6.89	S.G.D.
60.00	6.72	4.06	2.83	16.63	261.4	7.93	S.G.D.
68.18	6.55	4.02	2.81	11.18	253.6	7.85	S.G.D.
71.43	6.43	4.59	3.94	15.86	331.1	8.58	S.G.D.
53.57	2.57	4.99	4.73	14.16	110.2	5.95	S.L.D.
75.00	6.75	4.11	2.91	16.55	270.0	8.02	S.G.D.
68.18	6.27	4.10	3.48	---	248.4	7.80	S.G.
68.18	4.77	5.94	5.93	16.59	369.3	8.90	S.L.D.
65.22	5.35	3.41	2.81	---	146.3	6.54	S.G.
71.43	7.29	3.43	5.53	---	350.2	8.75	FAR.
75.00	7.20	5.01	3.26	4.11	476.3	9.69	S.G.D.
68.18	4.50	5.19	5.19	16.22	270.4	8.02	S.G.D.
71.43	5.86	5.05	4.81	16.57	361.5	8.84	S.G.D.
78.95	9.47	4.97	2.09	---	510.2	9.91	S.G.
55.56	4.67	4.00	3.94	---	166.9	6.83	S.G.
75.00	9.30	5.01	2.59	---	518.8	9.97	S.G.
78.95	4.74	6.33	6.33	16.53	409.5	9.21	S.L.D.
62.50	6.50	3.40	1.21	9.26	164.2	6.79	S.G.D.
71.43	4.86	5.68	5.67	15.86	352.8	8.77	S.G.D.
68.18	6.55	4.10	3.06	16.59	263.1	7.95	S.G.D.
75.00	4.65	6.37	6.36	10.24	458.7	9.57	S.G.D.
68.18	3.82	5.19	5.17	16.22	212.8	7.41	S.L.D.
71.43	4.57	6.79	6.74	16.57	438.4	9.43	S.L.D.
60.00	6.00	3.51	2.47	---	170.5	6.88	S.G.
71.43	6.43	5.05	4.86	---	377.1	8.96	S.G.
62.50	5.75	3.44	2.38	16.62	159.7	6.73	S.G.D.
60.00	6.96	3.99	2.67	---	254.6	7.86	S.G.
71.43	4.29	8.49	7.38	---	407.6	9.22	S.L.
68.18	6.41	4.10	3.16	16.59	259.0	7.91	S.G.D.
75.00	6.75	4.11	2.89	15.14	270.4	8.02	S.G.D.
53.57	2.46	4.99	4.63	16.38	99.1	5.74	S.L.D.

78.95	9.79	4.97	1.19	--	513.1	9.93	S.G.
65.22	5.22	3.66	3.15	16.25	169.4	6.86	S.G.D.
78.95	4.26	9.73	9.39	16.53	771.8	11.38	S.L.D.
65.22	5.48	4.06	3.55	11.69	223.2	7.53	S.G.D.
51.72	2.79	5.02	4.78	16.68	122.5	6.16	S.L.D.
71.43	10.00	3.53	4.93	10.71	381.4	9.00	F.C.
65.22	4.17	5.48	5.32	--	223.9	7.55	S.L.
71.43	4.71	5.68	5.64	10.71	365.7	8.87	S.G.D.
83.33	9.17	5.92	4.15	9.26	794.2	11.49	S.G.D.
83.33	8.50	3.54	8.04	9.26	810.0	11.57	F.C.
62.50	6.12	3.33	1.80	--	151.3	6.61	S.G.

3-D BED PROBE POSITION=(0CM,35CM)

SUPERFICIAL GAS VELOCITY=12.46CM/SEC PARTICLE SIZE:250-355

UB	AL	RF	RR	RW	VB	DE	SHAPE
60.00	4.92	4.13	4.05	---	189.1	7.12	S.G.
60.00	5.52	5.44	5.35	16.31	386.8	9.04	S.G.D.
57.69	3.46	4.58	4.56	16.33	149.0	6.58	S.L.D.
65.22	4.83	5.48	5.24	7.24	388.1	9.05	S.G.D.
65.22	5.09	4.84	4.39	6.34	320.0	8.49	S.G.D.
75.00	7.50	4.02	1.84	16.55	270.1	8.02	S.G.D.
53.57	4.50	3.55	3.30	16.67	136.2	6.38	S.G.D.
60.00	4.92	4.99	4.99	---	254.5	7.88	S.L.
65.22	4.83	6.34	6.25	8.87	499.9	9.85	S.G.D.
65.22	6.00	4.10	3.42	16.25	245.1	7.76	S.G.D.
55.56	5.33	3.56	2.93	16.35	163.5	6.78	S.G.D.
65.22	4.04	7.24	7.05	16.61	406.8	9.19	S.L.D.
62.50	5.50	4.09	3.67	16.62	224.4	7.54	S.G.D.
65.22	4.83	5.48	4.92	5.48	426.2	9.34	S.G.D.
62.50	7.25	4.52	3.31	16.62	353.3	8.77	S.G.D.
55.56	3.22	5.05	5.02	10.33	174.9	6.94	S.L.D.
71.43	7.86	3.43	6.16	16.57	468.0	9.63	P.C.
60.00	6.96	3.55	1.02	---	187.8	7.11	S.G.
62.50	6.00	5.05	4.77	16.62	371.7	8.92	S.G.D.
71.43	7.71	3.66	7.39	15.86	659.1	10.80	P.C.
71.43	7.71	5.05	3.95	16.57	476.7	9.69	S.G.D.
60.00	5.40	4.06	3.83	---	206.8	7.34	S.G.
71.43	7.71	5.68	5.30	---	580.7	10.35	S.G.
78.95	5.53	9.73	8.77	---	756.5	11.34	S.L.
68.18	7.23	3.57	6.61	16.59	494.3	9.81	P.C.
60.00	4.68	5.44	5.39	---	267.1	8.01	S.L.
57.69	3.46	6.85	5.95	---	214.4	7.45	S.L.
57.69	4.50	6.85	6.80	16.33	436.7	9.41	S.L.D.
60.00	4.08	3.37	3.21	16.63	110.2	5.95	S.G.D.
78.95	7.42	3.46	5.32	7.64	530.6	10.04	P.C.
68.18	6.82	3.42	0.39	---	167.6	6.84	S.G.
62.50	6.50	3.48	1.49	9.26	174.7	6.94	S.G.D.
62.50	5.00	4.09	3.73	9.26	210.3	7.38	S.G.D.
60.00	4.68	5.91	5.91	16.63	356.7	8.80	S.L.D.
78.95	4.42	9.73	8.15	---	506.8	9.92	S.L.
48.39	4.35	4.11	4.04	16.70	171.2	6.89	S.G.D.
68.18	5.86	3.35	1.64	3.42	154.4	6.66	S.G.D.
68.18	6.82	3.35	5.00	---	267.7	8.00	PAR.
62.50	4.37	6.37	6.05	---	295.6	8.29	S.L.

55.56	4.67	4.00	3.94	--	166.9	6.83	S.G.
65.22	6.26	4.84	4.62	--	338.4	8.65	S.G.
60.00	3.72	5.91	5.81	16.31	253.9	7.86	S.L.D.
62.50	4.12	5.88	5.81	7.65	373.2	8.93	S.G.D.
68.18	5.86	5.19	4.45	5.94	433.3	9.39	S.G.D.
60.00	3.96	5.44	5.24	--	203.1	7.31	S.L.
65.22	6.13	5.48	5.27	16.61	445.9	9.48	S.G.D.
71.43	7.43	3.66	7.21	16.57	604.5	10.49	P.C.
60.00	4.20	4.99	4.99	16.63	227.9	7.58	S.L.D.
65.22	6.00	7.24	7.13	--	592.4	10.45	S.L.
68.18	8.32	3.42	6.28	16.59	513.8	9.94	P.C.
60.00	3.96	5.91	5.58	--	226.4	7.58	S.L.
71.43	6.00	6.79	6.76	16.57	644.5	10.72	S.G.D.
57.69	5.54	3.45	2.75	--	154.8	6.66	S.G.
68.18	6.14	5.19	4.78	11.18	416.3	9.26	S.G.D.
68.18	5.45	4.02	3.50	11.22	218.7	7.48	S.G.D.
68.18	6.82	3.62	1.57	16.22	197.8	7.23	S.G.D.
57.69	3.46	6.32	6.08	16.65	251.7	7.83	S.L.D.
71.43	7.71	5.05	3.77	10.71	482.8	9.73	S.G.D.
60.00	3.96	5.91	5.85	16.31	279.5	8.11	S.L.D.
71.43	6.00	5.05	4.96	--	344.7	8.70	S.G.
55.56	1.89	10.33	8.19	16.66	228.6	7.59	S.L.D.
62.50	4.00	5.88	5.67	6.37	397.3	9.12	S.G.D.
60.00	6.96	3.99	2.67	--	254.6	7.86	S.G.
55.56	5.44	3.61	2.94	16.66	171.3	6.89	S.G.D.
65.22	5.87	6.34	6.30	16.61	552.5	10.18	S.G.D.
65.22	4.17	7.24	6.56	--	320.0	8.51	S.L.
71.43	8.29	3.53	6.89	16.57	615.4	10.55	P.C.
57.69	3.46	4.58	4.57	13.14	154.4	6.66	S.L.D.
78.95	6.95	7.64	7.56	16.53	974.6	12.30	S.G.D.
62.50	6.12	5.05	4.72	16.28	381.1	8.99	S.G.D.
75.00	8.40	3.45	5.40	7.80	647.5	10.73	P.C.
65.22	5.09	4.84	4.39	6.34	320.0	8.49	S.G.D.
78.95	5.68	7.64	7.10	7.64	995.5	12.39	S.G.D.
57.69	3.46	8.10	7.60	16.65	388.5	9.05	S.L.D.
57.69	4.50	5.02	5.00	13.14	262.4	7.94	S.G.D.
62.50	4.25	6.37	6.32	16.28	353.8	8.77	S.L.D.
65.22	6.00	4.57	4.33	--	290.2	8.21	S.G.
71.43	7.14	4.59	3.81	--	353.6	8.77	S.G.
68.18	7.23	3.57	6.61	16.59	494.3	9.81	P.C.
68.18	7.91	3.42	6.12	16.59	464.4	9.61	P.C.
55.56	4.00	6.35	6.25	16.66	318.4	8.47	S.L.D.
46.87	2.44	5.46	4.97	16.45	111.8	5.98	S.L.D.
57.69	5.65	5.47	5.37	16.65	402.2	9.16	S.G.D.
68.18	5.86	5.94	5.74	11.18	517.7	9.96	S.G.D.
55.56	6.33	3.44	1.72	16.35	168.2	6.85	S.G.D.
57.69	4.73	4.58	4.51	16.65	231.6	7.62	S.G.D.
65.22	5.87	6.34	6.30	16.61	552.5	10.18	S.G.D.

48.39	4.55	4.00	3.87	16.70	172.6	6.91	S.G.D.
71.43	7.86	3.48	6.42	16.57	507.0	9.89	P.C.
65.22	6.13	4.84	4.45	16.61	350.3	8.75	S.G.D.
62.50	6.37	3.40	1.43	9.26	163.5	6.78	S.G.D.
71.43	8.29	3.59	6.60	--	566.2	10.26	PAR.
62.50	5.25	4.52	4.32	16.28	257.6	7.89	S.G.D.
75.00	7.05	3.55	0.50	5.49	188.0	7.11	S.G.D.
55.56	3.33	5.05	4.99	13.65	170.9	6.88	S.L.D.
75.00	7.20	6.37	6.06	16.55	719.5	11.12	S.G.D.
60.00	4.80	4.13	3.96	16.31	195.5	7.20	S.G.D.
83.33	11.17	3.48	6.13	9.26	1142.2	12.97	P.C.
60.00	6.72	4.06	3.06	--	257.9	7.90	S.G.
65.22	4.04	7.24	7.05	16.61	406.8	9.19	S.L.D.

3-D BED PROBE POSITION=(2CM,35CM)

SUPERFICIAL GAS VELOCITY=12.46CM/SEC PARTICLE SIZE:250-355

UB	AL	RF	RR	RW	VB	DE	SHAPE
65.22	4.83	3.49	3.23	--	137.9	6.41	S.G.
38.46	3.69	8.61	8.28	14.75	515.9	9.95	S.L.D.
75.00	6.60	3.55	1.43	5.01	186.2	7.09	S.G.D.
65.22	8.35	4.57	2.56	--	390.4	9.07	S.G.
88.24	5.29	6.72	6.57	--	436.5	9.44	S.L.
53.57	2.68	4.99	4.42	--	92.4	5.62	S.L.
45.45	2.36	7.64	7.34	10.11	271.5	8.03	S.L.D.
55.56	4.67	4.00	3.94	--	166.9	6.83	S.G.
71.43	10.43	3.53	4.76	--	371.1	8.92	PAR.
60.00	4.20	5.91	5.66	--	250.2	7.84	S.L.
57.69	4.38	4.09	4.08	--	158.7	6.72	S.G.
57.69	3.46	6.32	5.63	--	194.3	7.21	S.L.
55.56	5.44	4.12	3.73	16.66	224.6	7.54	S.G.D.
65.22	4.04	6.34	6.25	16.61	323.5	8.52	S.L.D.
57.69	5.54	4.58	3.65	4.58	320.4	8.49	S.G.D.
57.69	6.46	3.58	2.13	--	187.5	7.10	S.G.
60.00	5.28	5.44	5.39	16.31	365.1	8.87	S.G.D.
71.43	7.14	4.59	3.81	--	353.6	8.77	S.G.
60.00	5.40	4.55	4.32	16.31	270.0	8.02	S.G.D.
40.54	3.24	7.62	6.24	--	216.2	7.47	S.L.
78.95	6.95	3.32	4.83	--	254.2	7.86	PAR.
57.69	3.46	4.58	4.44	--	128.9	6.29	S.L.
68.18	4.50	6.94	6.87	16.59	444.8	9.47	S.L.D.
55.56	6.33	3.44	1.72	16.35	168.2	6.85	S.G.D.
41.67	3.33	5.37	4.97	--	148.6	6.59	S.L.
60.00	5.16	4.55	4.51	--	236.6	7.67	S.G.
83.33	7.67	3.54	5.11	7.22	646.6	10.73	P.C.
44.12	2.82	16.72	9.30	--	395.3	9.13	S.L.
83.33	5.50	4.12	3.70	16.51	227.1	7.57	S.G.D.
53.57	2.79	4.99	4.76	16.38	121.4	6.14	S.L.D.
68.18	5.45	4.02	3.58	16.22	215.2	7.43	S.G.D.
53.57	4.50	3.47	3.20	16.67	130.4	6.29	S.G.D.
57.69	3.58	6.32	6.12	16.65	265.2	7.97	S.L.D.
53.57	4.50	3.47	3.20	16.67	130.4	6.29	S.G.D.
68.18	6.82	3.35	5.00	--	267.7	8.00	PAR.
65.22	4.83	4.84	4.19	4.84	325.0	8.53	S.G.D.
100.00	10.80	3.31	6.22	16.41	654.6	10.77	P.C.
55.56	1.89	10.33	5.95	--	108.7	5.94	S.L.
46.87	4.87	4.02	3.81	16.71	189.9	7.13	S.G.D.
65.22	6.00	4.10	3.63	--	237.6	7.68	S.G.

78.95	6.47	3.46	1.70	--	171.5	6.89	S.G.
83.33	8.33	5.92	4.43	7.22	755.4	11.30	S.G.D.
88.24	9.71	3.39	4.86	--	359.4	8.82	PAR.
60.00	3.96	3.43	3.32	16.63	109.8	5.94	S.G.D.
50.00	4.10	6.80	6.68	16.69	372.5	8.93	S.L.D.
62.50	6.37	3.40	1.43	9.26	163.5	6.78	S.G.D.
65.22	6.26	4.57	4.24	--	305.2	8.35	S.G.
57.69	3.46	6.85	6.54	16.65	288.9	8.20	S.L.D.
78.95	7.42	6.33	5.13	6.33	828.6	11.65	S.G.D.
55.56	3.22	7.22	6.01	--	200.5	7.28	S.L.
75.00	5.55	3.55	2.94	--	164.8	6.80	S.G.
83.33	11.17	3.48	6.13	9.26	1142.2	12.97	P.C.
71.43	7.43	3.53	6.52	16.57	494.3	9.81	P.C.
46.87	2.34	4.88	4.50	16.19	88.1	5.52	S.L.D.
45.45	3.55	5.05	4.82	--	152.7	6.65	S.L.
78.95	6.63	3.58	1.46	4.97	190.5	7.14	S.G.D.
57.69	4.96	5.02	5.02	--	260.2	7.94	S.L.
51.72	4.86	4.00	3.90	--	176.5	6.96	S.G.
60.00	6.00	3.51	2.47	--	170.5	6.88	S.G.
71.43	6.00	6.79	6.76	16.57	644.5	10.72	S.G.D.
62.50	7.25	4.09	2.61	--	277.0	8.09	S.G.
60.00	4.92	4.99	4.45	5.44	344.8	8.70	S.G.D.
53.57	7.29	3.47	5.68	--	368.6	8.90	PAR.
62.50	6.25	4.09	3.48	--	246.8	7.78	S.G.
93.75	7.50	5.46	4.73	16.45	551.2	10.17	S.G.D.
51.72	3.62	5.85	5.41	--	191.3	7.17	S.L.
83.33	10.83	4.18	4.39	16.51	328.1	8.56	P.C.
51.72	4.24	6.78	6.69	16.40	391.6	9.08	S.L.D.
71.43	7.00	3.59	1.12	--	193.5	7.18	S.G.
60.00	6.96	3.55	1.02	--	187.8	7.11	S.G.
71.43	7.86	3.43	6.16	16.57	468.0	9.63	P.C.
88.24	6.18	4.52	3.99	16.48	309.2	8.39	S.G.D.
45.45	5.09	4.50	4.46	--	228.2	7.58	S.G.
50.00	4.50	5.05	5.04	16.69	256.5	7.88	S.G.D.
75.00	7.05	3.50	4.00	5.01	539.2	10.10	P.C.
83.33	8.00	4.02	0.63	--	273.1	8.05	S.G.
62.50	4.12	5.88	5.81	7.65	373.2	8.93	S.G.D.
40.54	3.81	14.07	13.94	14.07	2355.4	16.51	S.G.D.
78.95	5.68	3.52	2.77	--	164.7	6.80	S.G.
93.75	10.50	3.33	6.35	16.45	664.9	10.83	P.C.
71.43	7.86	3.66	7.42	16.57	676.5	10.89	P.C.
53.57	2.46	4.99	4.31	--	79.6	5.35	S.L.
46.87	4.12	4.02	4.02	--	141.7	6.47	S.G.
55.56	4.11	6.35	6.35	10.33	385.1	9.03	S.L.D.
68.18	5.86	4.98	4.22	5.94	392.9	9.09	S.G.D.
78.95	7.26	4.07	2.52	--	273.0	8.05	S.G.
45.45	2.36	5.49	4.95	16.72	106.4	5.88	S.L.D.
44.12	1.94	12.92	10.90	16.72	439.9	9.44	S.L.D.

75.00	7.05	3.50	4.00	5.01	539.2	10.10	P.C.
62.50	6.37	3.40	1.43	9.26	163.5	6.78	S.G.D.
68.18	5.86	3.35	2.07	16.59	152.2	6.62	S.G.D.
75.00	9.15	3.50	6.50	--	607.0	10.50	PAR.
88.24	9.71	3.57	7.04	--	754.7	11.30	PAR.
65.22	4.83	5.48	5.24	7.24	388.1	9.05	S.G.D.
57.69	6.69	3.54	1.38	9.98	184.0	7.06	S.G.D.
51.72	3.83	6.78	6.10	--	253.2	7.87	S.L.
75.00	6.30	3.37	1.30	5.01	158.5	6.71	S.G.D.
53.57	4.93	5.15	5.11	16.67	300.9	8.31	S.G.D.
62.50	5.25	4.02	3.67	16.28	206.7	7.34	S.G.D.
44.12	3.26	7.59	7.07	16.72	313.2	8.43	S.L.D.

3-D BED PROBE POSITION=(4CM,35CM)

SUPERFICIAL GAS VELOCITY=12.46CM/SEC PARTICLE SIZE:250-355

UB	AL	RF	RR	RW	VB	DE	SHAPE
75.00	2.55	10.24	8.87	16.55	376.8	8.96	S.L.D.
60.00	5.04	5.44	5.43	--	300.2	8.33	S.L.
53.57	2.68	4.99	4.42	--	92.4	5.62	S.L.
65.22	6.00	3.41	2.06	16.61	160.5	6.74	S.G.D.
57.69	5.42	4.02	3.77	--	204.9	7.31	S.G.
83.33	8.67	4.12	7.65	--	796.4	11.50	PAR.
65.22	6.26	4.57	4.24	--	305.2	8.35	S.G.
62.50	5.37	4.52	4.29	16.62	264.5	7.96	S.G.D.
62.50	5.00	12.16	11.90	12.16	2289.3	16.35	S.G.D.
57.69	4.38	4.09	4.08	--	158.7	6.72	S.G.
60.00	5.40	12.67	10.38	--	995.6	12.42	S.L.
53.57	2.68	4.56	4.16	--	82.7	5.42	S.L.
68.18	5.73	3.42	2.53	--	155.8	6.68	S.G.
78.95	6.32	3.37	1.65	--	158.8	6.72	S.G.
57.69	6.12	5.02	4.90	--	350.1	8.74	S.G.
55.56	4.67	4.00	3.94	--	166.9	6.83	S.G.
93.75	7.12	3.33	4.36	--	212.6	7.41	PAR.
57.69	4.27	6.32	6.30	13.14	370.5	8.91	S.L.D.
51.72	3.72	16.40	10.40	--	660.3	10.83	S.L.
68.18	5.45	3.42	2.75	--	149.8	6.59	S.G.
53.57	2.79	4.99	4.76	16.38	121.4	6.14	S.L.D.
55.56	10.67	4.12	9.66	16.35	1547.0	14.35	P.C.
60.00	5.64	6.78	6.69	--	489.9	9.81	S.L.
55.56	6.33	3.44	1.72	16.35	168.2	6.85	S.G.D.
40.54	2.76	9.51	6.70	--	205.1	7.34	S.L.
78.95	8.84	3.41	6.00	--	500.0	9.85	PAR.
53.57	2.57	4.99	4.68	16.67	106.0	5.87	S.L.D.
68.18	4.64	4.53	4.16	5.94	256.2	7.88	S.G.D.
78.95	8.68	3.37	5.32	7.64	600.3	10.47	P.C.
53.57	4.50	3.47	3.20	16.67	130.4	6.29	S.G.D.
55.56	4.89	16.66	11.79	--	1128.5	12.95	S.L.
55.56	1.89	10.33	5.95	--	108.7	5.94	S.L.
57.69	5.54	3.45	2.75	--	154.8	6.66	S.G.
57.69	3.46	6.32	5.63	--	194.3	7.21	S.L.
71.43	7.14	4.59	3.81	--	353.6	8.77	S.G.
55.56	4.56	5.50	5.42	--	259.7	7.94	S.L.
88.24	8.47	3.44	6.61	12.92	578.8	10.34	P.C.
57.69	5.65	4.09	3.78	--	221.3	7.51	S.G.
55.56	1.56	13.65	11.47	16.35	395.2	9.10	S.L.D.
57.69	6.46	3.58	2.13	--	187.5	7.10	S.G.

75.00	8.55	3.34	4.72	--	299.6	8.30	FAR.
57.69	4.85	3.42	2.97	16.65	137.0	6.40	S.G.D.
65.22	5.35	4.06	3.85	--	204.7	7.31	S.G.
71.43	3.43	16.57	10.09	--	569.8	10.31	S.L.
55.56	3.33	5.05	4.99	13.65	170.9	6.88	S.L.D.
62.50	5.50	4.09	3.67	16.62	224.4	7.54	S.G.D.
93.75	7.69	3.30	5.39	8.27	346.7	8.72	F.C.
53.57	4.18	14.16	13.94	16.67	1893.8	15.35	S.L.D.
55.56	1.67	13.65	11.66	16.35	441.9	9.45	S.L.D.
88.24	9.71	3.44	6.42	--	628.9	10.63	FAR.
60.00	5.28	4.13	3.96	--	207.2	7.34	S.G.
51.72	4.86	4.00	3.90	--	176.5	6.96	S.G.
65.22	5.48	3.41	2.71	--	149.4	6.58	S.G.
57.69	3.58	5.47	5.38	16.65	209.1	7.36	S.L.D.
88.24	5.82	3.44	2.48	--	159.7	6.73	S.G.
53.57	2.46	4.56	4.30	16.67	85.9	5.47	S.L.D.
57.69	3.46	4.58	4.44	--	128.9	6.29	S.L.
51.72	4.76	4.52	4.51	--	208.8	7.36	S.G.
75.00	7.50	3.55	7.03	16.55	580.7	10.35	F.C.
62.50	5.50	4.09	3.67	16.62	224.4	7.54	S.G.D.
68.18	9.68	3.38	4.10	5.19	775.5	11.40	F.C.
55.56	6.33	3.44	1.72	16.35	168.2	6.85	S.G.D.
55.56	6.56	5.50	5.40	--	447.9	9.49	S.G.
57.69	4.38	13.14	9.80	--	705.2	11.07	S.L.
50.00	4.30	6.80	6.33	--	312.0	8.44	S.L.
48.39	3.77	6.20	6.07	16.70	279.5	8.11	S.L.D.
62.50	7.50	3.48	5.81	--	397.6	9.12	FAR.
83.33	9.67	4.02	7.62	--	880.7	11.89	FAR.
55.56	4.89	4.06	3.97	--	182.1	7.03	S.G.
60.00	4.20	4.55	4.54	16.63	194.9	7.19	S.G.D.
60.00	5.28	4.13	3.96	--	207.2	7.34	S.G.
55.56	5.00	5.05	5.00	16.66	296.2	8.27	S.G.D.
48.39	3.87	5.89	5.53	--	216.3	7.47	S.L.
65.22	4.04	6.34	6.25	16.61	323.5	8.52	S.L.D.
60.00	4.92	4.13	4.05	--	189.1	7.12	S.G.
55.56	4.56	5.50	5.50	16.66	302.9	8.33	S.L.D.
65.22	4.04	6.34	6.25	16.61	323.5	8.52	S.L.D.
57.69	4.50	6.85	6.80	16.33	436.7	9.41	S.L.D.
62.50	7.25	4.09	2.61	--	277.0	8.09	S.G.
48.39	4.35	8.09	7.90	16.70	556.6	10.21	S.L.D.
51.72	3.41	6.78	6.47	16.40	278.7	8.10	S.L.D.
88.24	8.12	3.44	5.87	--	439.9	9.44	FAR.
60.00	5.04	7.80	7.75	16.63	648.6	10.74	S.L.D.
53.57	6.21	3.35	1.75	--	155.4	6.67	S.G.
75.00	5.70	5.01	4.81	16.55	345.0	8.70	S.G.D.
60.00	3.72	6.78	6.68	12.67	350.6	8.75	S.L.D.
51.72	4.03	4.11	4.11	--	141.5	6.48	S.L.
62.50	6.00	6.37	6.36	--	494.8	9.84	S.L.

65.22	6.26	4.57	4.24	--	305.2	8.35	S.G.
71.43	7.14	4.59	3.81	--	353.6	8.77	S.G.
51.72	3.00	5.85	5.71	11.09	202.2	7.28	S.L.D.
83.33	8.50	7.22	6.70	16.51	1108.6	12.84	S.G.D.
55.56	5.00	3.61	3.33	--	152.7	6.63	S.G.
55.56	5.00	7.22	6.87	--	436.2	9.44	S.L.
65.22	4.04	6.34	6.25	16.61	323.5	8.52	S.L.D.
62.50	4.75	4.56	4.49	16.62	231.5	7.62	S.G.D.
60.00	7.32	5.44	5.11	--	505.3	9.88	S.G.
55.56	5.11	8.51	8.44	16.66	778.6	11.41	S.L.D.
71.43	6.29	3.59	2.19	16.57	186.9	7.09	S.G.D.
78.95	6.16	3.37	1.90	--	157.2	6.70	S.G.

3-D BED PROBE POSITION=(6CM,35CM)

SUPERFICIAL GAS VELOCITY=12.46CM/SEC PARTICLE SIZE:250-355

UB	AL	RF	RR	RW	VB	DE	SHAPE
46.87	3.75	4.08	4.06	--	124.9	6.22	S.L.
53.57	2.68	4.99	4.42	--	92.4	5.62	S.L.
62.50	4.25	9.26	8.94	16.62	693.2	10.98	S.L.D.
60.00	6.72	3.51	1.41	--	179.8	7.00	S.G.
55.56	4.67	4.00	3.94	--	166.9	6.83	S.G.
51.72	4.66	4.11	3.98	16.68	186.9	7.09	S.G.D.
115.38	7.15	4.09	2.48	16.33	276.2	8.08	S.G.D.
65.22	4.83	5.48	5.24	7.24	388.1	9.05	S.G.D.
83.33	8.67	4.12	7.65	--	796.4	11.50	FAR.
75.00	7.35	3.32	4.95	--	282.9	8.14	FAR.
53.57	2.57	4.99	4.68	16.67	106.0	5.87	S.L.D.
60.00	5.28	5.44	5.39	16.63	364.2	8.86	S.G.D.
62.50	4.37	5.88	5.69	--	266.0	8.00	S.L.
60.00	4.56	4.55	4.35	7.80	240.8	7.72	S.G.D.
57.69	4.38	4.09	4.08	--	158.7	6.72	S.G.
65.22	4.04	6.34	6.25	16.61	323.5	8.52	S.L.D.
71.43	7.14	4.59	3.81	--	353.6	8.77	S.G.
75.00	6.75	3.37	5.03	--	268.4	8.00	FAR.
65.22	3.52	3.60	3.60	--	94.5	5.67	S.L.
93.75	7.87	3.36	6.32	8.27	480.4	9.72	F.C.
60.00	5.04	7.80	7.75	16.63	648.6	10.74	S.L.D.
62.50	6.00	6.37	6.36	--	494.8	9.84	S.L.
65.22	6.26	4.57	4.24	--	305.2	8.35	S.G.
68.18	4.77	4.53	4.45	16.59	229.9	7.60	S.G.D.
60.00	2.88	6.78	6.22	16.63	210.1	7.38	S.L.D.
57.69	3.46	4.58	4.44	--	128.9	6.29	S.L.
88.24	5.29	3.32	2.52	16.48	139.4	6.43	S.G.D.
60.00	5.28	5.44	5.39	16.31	365.1	8.87	S.G.D.
57.69	5.19	3.49	3.05	--	149.2	6.58	S.G.
65.22	4.83	4.84	4.19	4.84	325.0	8.53	S.G.D.
68.18	7.23	3.57	6.61	16.59	494.3	9.81	F.C.
68.18	7.36	3.57	4.10	5.19	642.5	10.71	F.C.
75.00	9.15	3.34	3.25	3.50	672.4	10.87	F.C.
83.33	14.33	3.42	7.72	--	1340.5	13.68	FAR.
78.95	5.37	9.73	8.70	--	718.6	11.14	S.L.
55.56	6.33	3.44	1.72	16.35	168.2	6.85	S.G.D.
71.43	3.43	16.57	10.09	--	569.8	10.31	S.L.
55.56	1.89	10.33	5.95	--	108.7	5.94	S.L.
83.33	6.17	3.38	1.91	--	158.3	6.71	S.G.
71.43	8.29	3.59	6.60	--	566.2	10.26	FAR.

88.24	12.71	3.44	7.35	--	1077.8	12.72	PAR.
83.33	6.83	3.35	4.96	--	264.1	7.96	PAR.
55.56	3.22	7.22	6.01	--	200.5	7.28	S.L.
53.57	4.93	6.37	6.37	16.67	437.8	9.42	S.L.D.
71.43	6.43	3.48	1.84	--	173.4	6.92	S.G.
65.22	6.00	4.10	3.63	--	237.6	7.68	S.G.
62.50	4.12	6.37	6.37	9.26	409.2	9.21	S.G.D.
60.00	5.28	4.13	3.96	--	207.2	7.34	S.G.
68.18	8.32	3.42	6.28	16.59	513.8	9.94	P.C.
55.56	1.67	13.65	11.66	16.35	441.9	9.45	S.L.D.
60.00	5.04	4.13	4.02	--	195.2	7.20	S.G.
51.72	3.21	6.78	6.76	8.96	345.1	8.70	S.L.D.
75.00	10.50	3.45	6.71	--	742.2	11.23	PAR.
48.39	4.55	4.00	3.87	16.70	172.6	6.91	S.G.D.
48.39	4.35	4.11	4.04	16.70	171.2	6.89	S.G.D.
51.72	4.45	6.78	6.72	16.40	420.8	9.30	S.L.D.
53.57	4.71	4.56	4.50	16.38	229.4	7.59	S.G.D.
50.00	4.30	6.80	6.33	--	312.0	8.44	S.L.
46.87	2.44	4.88	4.53	16.45	93.8	5.64	S.L.D.
71.43	5.86	4.59	4.41	--	283.9	8.15	S.G.
60.00	7.32	5.44	5.11	--	505.3	9.88	S.G.
53.57	4.07	16.38	16.25	16.38	3412.4	18.68	S.G.D.
71.43	7.86	3.43	6.16	16.57	468.0	9.63	P.C.
55.56	3.33	5.05	4.99	13.65	170.9	6.88	S.L.D.
68.18	6.82	3.35	5.00	--	267.7	8.00	PAR.
78.95	8.05	6.33	6.10	--	743.7	11.24	S.G.
71.43	6.29	3.59	2.19	16.57	186.9	7.09	S.G.D.
62.50	5.50	3.63	2.88	12.16	176.0	6.95	S.G.D.
93.75	7.87	3.33	5.20	--	334.0	8.61	PAR.
65.22	7.17	5.48	5.21	--	499.7	9.85	S.G.
65.22	5.35	3.49	2.80	16.61	157.0	6.69	S.G.D.
93.75	7.87	3.30	3.78	4.56	411.0	9.22	P.C.
75.00	9.45	3.40	6.15	--	561.1	10.23	PAR.
83.33	11.17	3.48	6.13	9.26	1142.2	12.97	P.C.
71.43	8.29	3.59	6.60	--	566.2	10.26	PAR.
53.57	2.79	4.15	3.92	--	78.4	5.33	S.L.
62.50	4.75	4.56	4.49	16.62	231.5	7.62	S.G.D.
51.72	3.00	5.85	5.71	11.09	202.2	7.28	S.L.D.
41.67	4.50	4.98	4.96	--	221.6	7.53	S.L.
68.18	5.86	4.98	4.49	8.53	374.7	8.94	S.G.D.
60.00	3.72	6.78	6.68	12.67	350.6	8.75	S.L.D.
55.56	5.11	8.51	8.44	16.66	778.6	11.41	S.L.D.
55.56	5.00	7.22	6.87	--	436.2	9.44	S.L.
78.95	9.16	3.65	4.32	--	268.2	8.00	PAR.
65.22	6.26	4.57	4.24	--	305.2	8.35	S.G.
57.69	5.54	3.45	2.75	--	154.8	6.66	S.G.
57.69	4.73	4.50	4.33	9.98	237.1	7.68	S.G.D.
50.00	7.70	3.39	6.31	9.26	474.1	9.67	P.C.

44.12	3.53	6.07	5.89	16.72	242.6	7.74	S.L.D.
68.18	6.00	3.30	1.77	16.59	148.0	6.56	S.G.D.
46.87	4.69	5.91	5.91	16.71	356.9	8.80	S.L.D.
60.00	4.20	4.55	4.54	16.63	194.9	7.19	S.G.D.
62.50	5.00	4.09	3.86	16.28	202.3	7.28	S.G.D.
44.12	3.88	5.54	5.29	--	201.3	7.29	S.L.
55.56	4.67	4.00	3.94	--	166.9	6.83	S.G.
40.54	6.49	3.34	0.94	6.77	156.2	6.68	S.G.D.
57.69	5.54	4.09	3.64	16.33	225.5	7.55	S.G.D.
57.69	10.85	3.94	4.56	16.65	354.8	8.78	P.C.
62.50	4.37	5.88	5.69	--	266.0	8.00	S.L.
65.22	6.13	3.45	2.01	16.61	166.9	6.83	S.G.D.

3-D BED PROBE POSITION=(8CM,35CM)

SUPERFICIAL GAS VELOCITY=12.46CM/SEC PARTICLE SIZE:250-355

UB	AL	RF	RR	RW	VB	DE	SHAPE
68.18	5.45	4.02	3.58	16.22	215.2	7.43	S.G.D.
46.87	2.44	4.88	4.53	16.45	93.8	5.64	S.L.D.
62.50	6.50	3.48	1.49	9.26	174.7	6.94	S.G.D.
60.00	5.40	5.44	5.37	16.63	375.1	8.95	S.G.D.
83.33	8.33	7.22	6.75	16.51	1084.9	12.75	S.G.D.
55.56	3.22	7.22	6.01	---	200.5	7.28	S.L.
51.72	4.86	4.00	3.78	16.68	186.9	7.09	S.G.D.
60.00	4.20	3.37	3.26	---	108.9	5.93	S.G.
55.56	4.00	6.35	6.25	16.66	318.4	8.47	S.L.D.
78.95	10.26	3.58	7.29	---	857.4	11.79	PAR.
60.00	3.84	5.44	5.40	16.31	231.9	7.62	S.L.D.
68.18	6.82	3.38	5.49	16.22	322.9	8.51	P.C.
68.18	9.14	3.38	6.35	16.59	578.5	10.34	P.C.
57.69	3.58	6.85	6.58	16.65	304.5	8.35	S.L.D.
62.50	4.00	5.88	5.53	5.88	418.0	9.28	S.G.D.
71.43	6.00	6.79	6.75	15.86	649.3	10.74	S.G.D.
65.22	6.26	4.84	4.39	16.61	358.3	8.81	S.G.D.
53.57	2.79	4.99	4.76	16.38	121.4	6.14	S.L.D.
60.00	5.28	4.13	3.96	---	207.2	7.34	S.G.
53.57	4.50	3.50	3.25	16.38	133.3	6.34	S.G.D.
62.50	6.00	5.05	4.77	16.28	372.2	8.92	S.G.D.
55.56	6.33	3.48	1.80	13.65	173.1	6.91	S.G.D.
71.43	7.57	5.05	4.03	15.86	470.2	9.65	S.G.D.
65.22	5.87	6.34	6.32	---	474.6	9.70	S.L.
55.56	4.67	4.06	3.91	16.66	182.8	7.04	S.G.D.
53.57	4.50	3.50	3.25	16.67	133.2	6.34	S.G.D.
60.00	4.80	4.55	4.46	16.31	233.6	7.64	S.G.D.
83.33	14.33	3.42	7.72	---	1340.5	13.68	PAR.
65.22	4.04	6.34	6.25	16.61	323.5	8.52	S.L.D.
60.00	4.08	5.91	5.62	---	238.2	7.71	S.L.
53.57	2.57	4.99	4.68	16.67	106.0	5.87	S.L.D.
65.22	3.91	7.24	7.03	16.25	389.3	9.06	S.L.D.
78.95	4.11	9.73	9.33	16.53	728.4	11.16	S.L.D.
75.00	10.50	3.50	6.96	---	799.3	11.51	PAR.
60.00	6.84	3.61	1.45	16.31	195.1	7.20	S.G.D.
62.50	7.25	4.52	3.59	---	346.5	8.71	S.G.
75.00	7.50	4.02	1.83	15.14	270.2	8.02	S.G.D.
57.69	4.50	6.85	6.80	16.33	436.7	9.41	S.L.D.
55.56	4.44	4.06	3.96	16.66	171.9	6.90	S.G.D.
60.00	5.04	4.13	3.89	16.31	207.2	7.34	S.G.D.

65.22	4.83	5.48	4.92	5.48	426.2	9.34	S.G.D.
57.69	3.46	5.02	4.77	--	145.5	6.54	S.L.
60.00	5.04	4.55	4.41	16.31	248.4	7.80	S.G.D.
55.56	3.33	5.50	5.40	13.65	198.0	7.23	S.L.D.
62.50	4.37	6.37	6.33	16.62	367.8	8.89	S.L.D.
57.69	4.38	4.09	4.08	--	158.7	6.72	S.G.
68.18	5.86	4.98	4.22	5.94	392.9	9.09	S.G.D.
60.00	4.20	4.55	4.54	16.63	194.9	7.19	S.G.D.
65.22	6.13	5.48	5.27	16.61	445.9	9.48	S.G.D.
55.56	1.78	10.33	8.04	16.66	205.6	7.32	S.L.D.
78.95	6.16	3.37	1.40	3.65	158.8	6.72	S.G.D.
65.22	5.35	4.10	3.91	--	208.3	7.35	S.G.
53.57	2.57	4.99	4.68	16.67	106.0	5.87	S.L.D.
57.69	3.46	6.32	6.08	16.65	251.7	7.83	S.L.D.
78.95	5.68	7.64	7.64	14.37	772.3	11.38	S.G.D.
57.69	6.46	4.02	3.20	--	245.4	7.77	S.G.
68.18	6.82	3.38	5.49	16.59	321.9	8.50	P.C.
51.72	2.79	5.02	4.78	16.68	122.5	6.16	S.L.D.
60.00	5.04	4.13	3.89	16.31	207.2	7.34	S.G.D.
57.69	7.27	4.09	2.57	--	276.5	8.08	S.G.
75.00	7.35	6.37	6.02	16.55	736.7	11.21	S.G.D.
60.00	6.96	3.99	2.67	--	254.6	7.86	S.G.
55.56	5.33	3.61	3.01	16.66	168.2	6.85	S.G.D.
68.18	5.59	6.94	6.68	8.53	733.0	11.19	S.G.D.
57.69	3.46	6.85	6.54	16.65	288.9	8.20	S.L.D.
60.00	4.92	4.99	4.99	--	254.5	7.88	S.L.
71.43	3.43	16.57	16.48	16.57	2947.4	17.79	S.G.D.
62.50	4.25	6.37	6.31	16.62	352.1	8.76	S.L.D.
48.39	4.55	4.00	3.87	16.70	172.6	6.91	S.G.D.
65.22	6.26	4.84	4.62	--	338.4	8.65	S.G.
55.56	4.78	3.61	3.04	6.35	159.0	6.72	S.G.D.
78.95	4.42	9.73	8.15	--	506.8	9.92	S.L.
55.56	3.33	5.05	4.99	13.65	170.9	6.88	S.L.D.
62.50	5.50	5.88	5.84	16.62	442.2	9.45	S.G.D.
65.22	7.70	3.60	6.39	--	493.8	9.81	PAR.
53.57	4.50	3.50	3.25	16.67	133.2	6.34	S.G.D.
60.00	5.40	4.06	3.83	--	206.8	7.34	S.G.
68.18	7.23	3.57	6.61	16.59	494.3	9.81	P.C.
78.95	7.42	6.33	5.13	6.33	828.6	11.65	S.G.D.
55.56	5.00	5.05	5.00	16.66	296.2	8.27	S.G.D.
53.57	2.68	4.56	4.37	16.67	98.6	5.73	S.L.D.
68.18	6.82	3.35	5.00	--	267.7	8.00	PAR.
71.43	7.57	6.79	6.74	--	768.1	11.36	S.G.
60.00	4.20	4.55	4.54	16.63	194.9	7.19	S.G.D.
65.22	6.26	4.57	4.24	--	305.2	8.35	S.G.
55.56	1.89	10.33	5.95	--	108.7	5.94	S.L.
60.00	4.92	4.55	4.44	16.63	240.7	7.72	S.G.D.
62.50	4.12	5.88	5.81	7.65	373.2	8.93	S.G.D.

71.43	7.57	3.59	6.90	16.57	565.0	10.26	P.C.
65.22	4.04	6.34	6.25	16.61	323.5	8.52	S.L.D.
55.56	3.33	5.50	5.47	10.33	216.3	7.45	S.L.D.
53.57	4.29	3.55	3.47	--	122.2	6.16	S.G.
60.00	5.40	4.06	3.66	16.31	216.4	7.45	S.G.D.
62.50	6.25	3.44	1.68	7.65	167.3	6.84	S.G.D.
68.18	8.32	3.42	6.28	16.59	513.8	9.94	P.C.
71.43	7.86	3.43	6.16	16.57	468.0	9.63	P.C.
55.56	5.33	3.61	3.01	16.66	168.2	6.85	S.G.D.
60.00	5.16	4.55	4.51	--	236.6	7.67	S.G.
65.22	4.83	5.48	5.24	7.24	388.1	9.05	S.G.D.
53.57	2.68	4.99	4.42	--	92.4	5.62	S.L.