

## **Copyright Warning & Restrictions**

The copyright law of the United States (Title 17, United States Code) governs the making of photocopies or other reproductions of copyrighted material.

Under certain conditions specified in the law, libraries and archives are authorized to furnish a photocopy or other reproduction. One of these specified conditions is that the photocopy or reproduction is not to be “used for any purpose other than private study, scholarship, or research.” If a user makes a request for, or later uses, a photocopy or reproduction for purposes in excess of “fair use” that user may be liable for copyright infringement,

This institution reserves the right to refuse to accept a copying order if, in its judgment, fulfillment of the order would involve violation of copyright law.

**Please Note: The author retains the copyright while the New Jersey Institute of Technology reserves the right to distribute this thesis or dissertation**

Printing note: If you do not wish to print this page, then select “Pages from: first page # to: last page #” on the print dialog screen

The Van Houten library has removed some of the personal information and all signatures from the approval page and biographical sketches of theses and dissertations in order to protect the identity of NJIT graduates and faculty.

FINITE ELEMENT MODELING OF  
A FEMORAL STEM IN A  
TOTAL HIP PROSTHESIS

by

ROBERT C. COHEN

Thesis submitted to the Faculty of the Graduate School  
of the New Jersey Institute of Technology in partial fulfillment  
of the requirements for the degree of  
Master of Science in Mechanical Engineering  
1984

APPROVAL SHEET

Title of Thesis: Finite Element Modeling of a Femoral  
Stem in a Total Hip Prosthesis

Name of Candidate: Robert C. Cohen

Thesis and Abstract Approved:

\_\_\_\_\_  
Dr. M. Pappas                      Date  
Professor  
Mechanical Engineering Dept.

\_\_\_\_\_  
Dr. H. Herman                      Date  
Professor  
Mechanical Engineering Dept.

\_\_\_\_\_  
Dr. B. Koplik                      Date  
Professor  
Mechanical Engineering Dept.

VITA

Name: Robert C. Cohen

Degree and date to be conferred: M.S.M.E., May 1984

Secondary education: Livingston High School, May 1979

Collegiate Institutions Attended	Dates	Degree	Date of Degree
New Jersey Inst. of Tech.	6/83-5/84	M.S.M.E.	May, 1984
	9/79-5/83	B.S.M.E.	May, 1983

Major: Mechanical Engineering

Positions held: Graduate Teaching Assistant, Physics Dept.,  
N.J.I.T., 9/83 - 5/84

## ABSTRACT

Title of Thesis: Finite Element Modeling of a  
Femoral Stem in a Total Hip Prosthesis

Robert C. Cohen, M.S.M.E., 1984

Thesis directed by: Professor M. Pappas

A three-dimensional model was produced to study of effects of stress on a femoral stem in a total hip prosthesis. Using the ANSYS General Purpose Finite Element Computer Program, a reproduction of the system was constructed for the loads acting on the hip joint at intervals of a walking cycle. With isotropic properties for cortical bone, cancellous bone, cement, and selected alloys, the model was generated using three-dimensional, isoparametric, eight-node, solid elements (STIF45). The model consists of over 700 nodes and 442 elements. This model can be used to produce computer calculated stress data, if disc storage space allows.

Blank Page

## PREFACE

A finite element model can be used to study the effects of some of the factors leading to the early failure of the femoral stem in total hip prosthesis. This study can be used to analyze the effects of stress on a certain femoral stem implanted in its proper environment in the quest to reduce fatigue failures. The model is generated with the use of the ANSYS General Purpose Finite Element Computer Program using three-dimensional solid elements. This model is intended to give an accurate representation of an actual prosthetic system involving forces, material properties, and incorporating the human walking cycle. Due to the limitations of available disc storage space on the institution's computer, the program could not finish its execution phase to produce complete stress results. If the reader wishes to perform the execution, the author is confident the program will produce satisfactory results on a larger system.



## ACKNOWLEDGEMENTS

To Dr. Michael Pappas, Mechanical Engineering Department of NJIT, for the sharing of his knowledge which will prove invaluable towards the completion of my education, and his sincere desire for the betterment of the biomechanical profession.

To Mr. Ghandikota Ramamurthy, and Mr. Robert Pescinski, for the many hours and days spent in the effort to achieve full execution of this program.

R.C. Cohen

## TABLE OF CONTENTS

	<u>Page</u>	
I	INTRODUCTION	1
	A. Background	1
	B. Finite Element Method	4
	C. Previous Femoral Stem Models	6
	D. Summary of 2-D and 3-D Models	10
II	OBJECTIVE OF PRESENT STUDY	11
III	SYSTEM TO BE MODELED	12
IV	IMPLANT MATERIALS	23
V	ANSYS AND STIF45 ELEMENT MODULE	34
VI	FORMULATION OF MODEL	37
VII	THE MODEL	46
VIII	DISCUSSION OF COMPUTER EXECUTION	58
IX	SUMMARY	60
X	REFERENCES	61
	APPENDIX A - Bone Cross Sections	63
	APPENDIX B - Selected Computer Printouts	65
	APPENDIX C - Tables of Nodes and Elements	68

## LIST OF FIGURES

	<u>Page</u>
Figure 1. Andriacchi's Finite Element Model	9
Figure 2. Sih's Finite Element Model	9
Figure 3. Total System of Study	13
Figure 4. Detail of Femoral Stem	15
Figure 5. to 8. Forces at Percentages in Walking Cycle	18- 21
Figure 9. Hip Joint Force During Walking Cycle	22
Figure 10. Implant Material Properties	29
Figure 11. The STIF45 Element	36
Figure 12. Cartesian Coordinate System	39
Figure 13. Placement of Nodes 1 to 30	41
Figure 14. to 23. Graphic Display of Elements	47- 56
Figure 24. The Complete Model	57
Figure 25. to 34. Bone Cross-Sections	64

## LIST OF TABLES

Table 1. Composition of Implant Alloys	31
Table 2. Table of Nodes	69
Table 3. Table of Elements	100

## I INTRODUCTION

### A. Background

The ultimate success or failure of a surgical implant depends on many elements including: The physical, mechanical, and biochemical properties of the implant material; the design, construction, and quality of the finished implant; the selection of the proper implant for the surgical technique to be carried out, the operative technique; and the postoperative management of the patient (Ref. 1). For the purpose of this study, mechanical considerations are to be the main objective.

The goals of total hip reconstruction are relief of pain and restoration of normal activity. In most cases, pain is reduced, and the range and function of movement is increased. The movement of the hip is produced by the articulation of a ball-and-socket joint (enarthrodial), formed by the reception of the head of the femur into the cup-shaped cavity of the acetabulum.

All patients who underwent total hip-replacement arthroplasty had a significant degree of disability caused by degenerative or rheumatoid arthritis or recurrent pain after previous surgical procedures performed on the hips (Ref. 2).

If the following criteria are fulfilled, it may be assumed that the most mechanically effective hip will be the result: 1) minimum muscular effort required to perform normal activities; 2) minimum joint contact force at the hip;

and 3) minimum bending moment at the neck-stem junction of the femoral component (Ref. 2).

It is a measure of the success of the procedure that the majority of patients are completely free from pain post-operatively, with greatly improved function and movement.

It is usually agreed that a total hip replacement should incorporate a ball and socket arrangement as in a natural joint. All prostheses in principle have a spherical, or approximately spherical, femoral head which resides in and articulates with a hemispherical acetabular component. The shape of the femoral component and the method of attachment to the remains of the femur play an important role in failure prevention.

The loads of the components, and, therefore, the stresses in them, and the forces within the muscles during normal activity are related to the geometry of the hip joint (Ref. 3).

Since the forces and moments acting on the hip joint can cause femoral stem loosening resulting in failure of the prosthesis, the mechanical behavior must be known. Theoretical stress analysis using finite elements could prove to be an invaluable aid in reducing the incidence of failure.

Loosening of the femoral stem has been variously reported as occurring in from four to twenty percent of patients. Many factors can be cited, but the most generally accepted is improper technique for insertion of cement (Ref. 4). It should be noted that mechanical failure of acrylic bone cement can impair the structural integrity of a total joint arthroplasty. Since the bone cement may be exposed to millions of loading

cycles after implantation, the fatigue behavior is a fundamental design consideration.

Many femoral stems do break. Most stems, when using scanning electron microscope examinations, show evidence of fatigue failure, with the crack initiating at the lateral surface of the stem where the tensile stresses would be expected to be highest. The crack then appeared to have progressed medially first by a low-cycle fatigue mode and then by rapid breakage (Ref. 5). In some cases, microscopic imperfections may have been the starting point of the failure.

The effect of inadequate medial support around the prosthesis is also a cause of stem fracture (Ref. 6).

The above stated causes of failure may be the effects of the following variables: 1) the angles of application of the force at the hip joint; 2) the orientation of the femoral component; 3) variations in the amount of stem support; and 4) variations in femoral-stem design (Ref. 7).

A femoral stem implanted in the femur is a system composed of cement, metal, and cortical and cancellous bone producing a complex mechanical situation. For this reason, the use of the computer incorporating finite element analysis is chosen.

## B. Finite Element Method

A finite element method can be distinguished by the following features:

- 1) The physical region of the problem is subdivided into subregions or finite elements.
- 2) One or more of the dependent variables is approximated in functional form over each element and hence over the whole domain. The parameters of this approximation subsequently become the unknowns of the problem.
- 3) Substitution of the approximations into the governing equations (or their equivalent) yields a set of equations in the unknown parameters. The solution of these equations yields the parameters and hence the approximate solution to the problem (Ref. 8).

Since the number of unknowns in the final set of equations is often very large, it is common practice to use matrix notation, both for conciseness and to facilitate computer programming.

The widespread adoption of the finite element method for increasing diverse problems has been facilitated by: 1) the inherent generality of the method; 2) its natural formulation in matrix language; 3) the availability of efficient procedures to solve very large sets of equations; and 4) the capability of modern computers (Ref. 8).

Three-dimensional problems involve a large number of degrees of freedom. For example, in solid mechanics, the

three displacements, and their first derivatives in the X, Y, and Z directions, respectively, cause the simple tetrahedral element to have forty-eight degrees of freedom. Even with a reasonable number of elements, the resulting system matrix equation can easily have several thousand unknowns. Hexadral (brick-shaped) elements can even produce more unknowns.

If the reader desires to study the derivations of the formulas used with three-dimension elements or if a more detailed explanation of the methods used is desired, Ref. 8 may be consulted.



### C. Previous Femoral Stem Models

Finite element models have been used many times in the past to study the behavior of the human femur and the behavior with an implant.

Most models are two-dimensional which at best can only approximate the true behavior of a three-dimensional system. Obviously, their rationale is that a two-dimensional element model can adequately model the characteristics of the proximal femur (Ref. 6). This may be true, but, when the forces and moments are applied to the femoral head, the resultants can only be properly specified by a three-dimensional system.

Even though, there remain at least two widely accepted two-dimensional studies, one by Andriacchi, et al. (Ref. 7), and the other by Sih, et al. (Ref. 6).

In summary, Andriacchi made his analytical model using a two-dimensional representation of the femoral stem, cement, and proximal half of the femur lying in the frontal plane of the stem. The elements chosen for this study were constant strain quadrilaterals and constant strain triangles (see Figure 1). This study showed that the tensile stresses were largest in magnitude along the middle portion of the stem and become compressive near the distal trip. The region of highest tensile stresses occurred in the middle one-third of the stem, the region where fractures are reported to occur. It should be noted that moments were not used in this study.

Sih used the "Axisymmetric Planar Elastic Structures" two-dimensional finite element program. He used twelve-noded

quadrilateral isoparametric elements with cubic displacement functions. As with this thesis study, he used a four material model (see Figure 2). His study showed total cement fractures occurring near the distal tip of the prosthesis. Other failure sites agreed with Andriacchi's results. Again all moments could not be taken into consideration, nor would it be possible to with this type of model.

With both of these two-dimensional models, the effects of muscle loadings in addition to the joint forces is neglected. Therefore, an accurate stress distribution could not be obtained.

Recently, Scholten et al (1978) have analyzed the proximal femur with implanted prosthesis. Their analysis is based on a three-dimensional model and includes nonhomogeneous properties and slip characteristics of the interface. Other three-dimensional analyses of the femur with the implanted hip prosthesis are by Crowninshield et al (1979) and Tarr et al (1979), (Ref. 9).

Crowninshield used tetrahedon three-dimensional elements to model a transverse section of the bone/cement/stem composite as taken from the middle third of the femur. A crude model was developed and did not take into account torsion about the femoral head nor did it take into account adduction forces.

Tarr et al constructs a model using hexahedral elements with two elements across the stem, two across the cement and one for the cortex of the bone. This model is also very crude and does not take into account muscle forces.

Recently, Huiskes et al (Ref. 9) composed a model made up of quadratic isoparametric general hexahedron elements to simulate one quarter of a stem/bone complex. This model was abandoned due to cost and complexity. The major drawback of his work is that only a circular prosthesis stem can be studied.

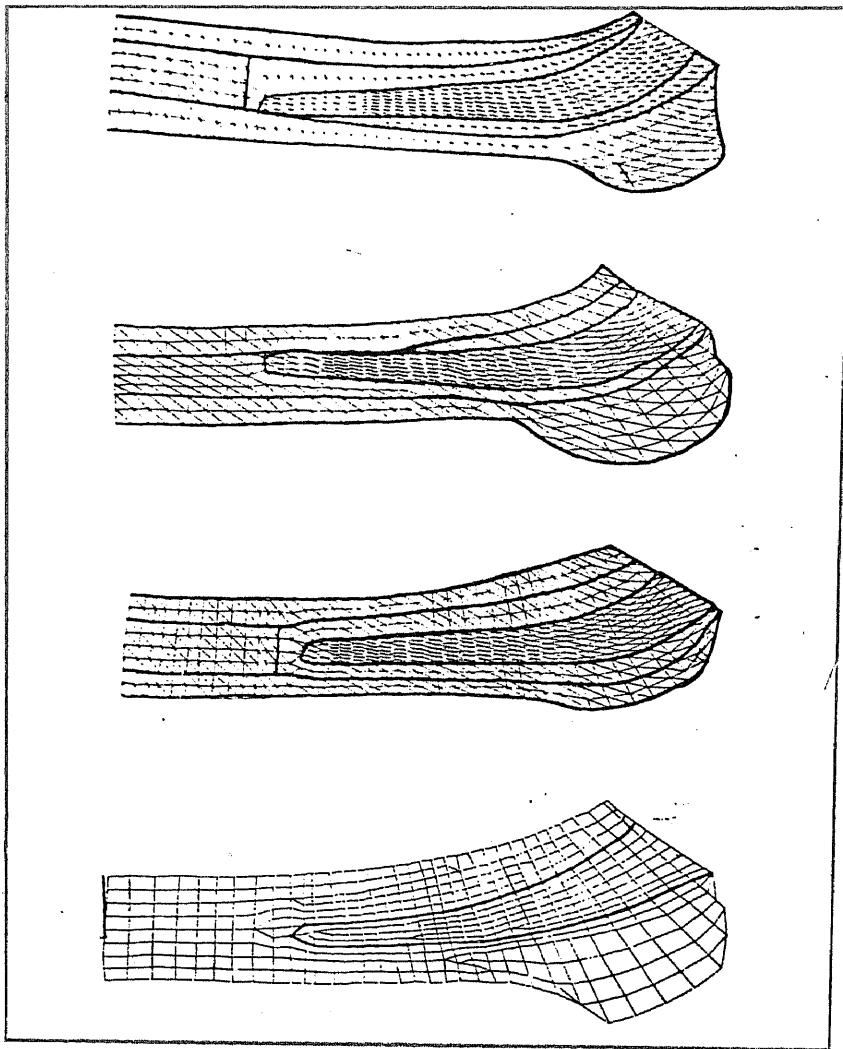

Figure 1.  
Andriacchi's Finite  
Element Model  
(Ref. 7 .)

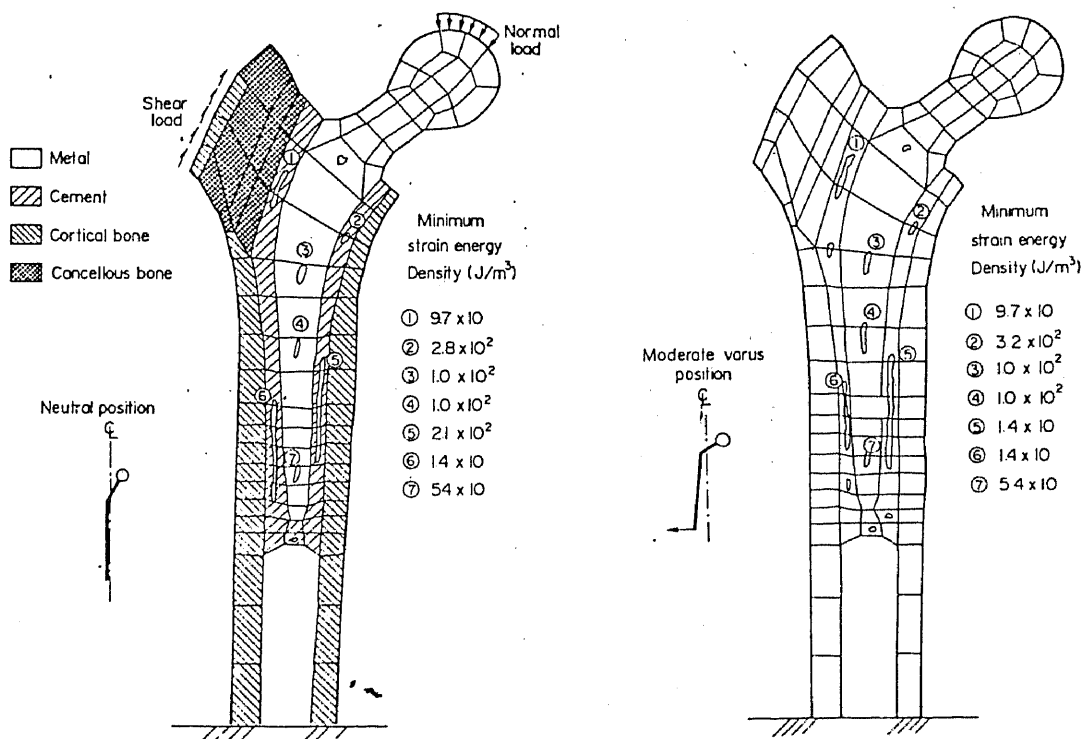

Figure 2.  
Sih's Finite Element Model  
(Ref. 6)

#### D. Summary of 2-D and 3-D Models

All of these models have severe limitations. At best they provide first approximations to the stresses and behaviors of the femoral components. The models do provide insight into how the stem can fracture due to loosening.

Even though three-dimensional analysis involves a large amount of data and more computer time than a two-dimensional analysis, if modeled properly, the three-dimensional system will come closest to an actual representation of a total hip prosthetic.

It should be noted that because of the uncertainties introduced in the problem and because of the uncertainties introduced in the data, one cannot expect to predict the stress distribution in these problems in an absolute sense. However, the finite element method will be more useful in a parametric study. An implant designed for life requires a better design. This is where the finite element method will be of great help. (Ref. 10).

## II OBJECTIVE OF PRESENT STUDY

The purpose of this study is to construct a finite element model of a femoral component stem within its simulated biomechanical environment using ANSYS General Purpose Finite Element computer program. With the constructed model using forces normally incurred during the walking cycle, stress values at node locations can be computed, if desired.

The model is to take into account muscle forces including adduction forces as well as joint forces. Hence, all forces and moments about a complete implanted prosthetic system are to be taken into consideration.

In an effort to come as close as possible to actuality, a three-dimensional model will be constructed. This way, moments in three directions can be properly simulated.

The complete model should be able to be executed in order to analyze the stress distributions in the total system, including the femoral stem, the bone cement, cancellous bone, and cortical bone, if the reader desires to do so.

### III SYSTEM TO BE MODELED

The system to be analyzed contains cortical and cancellous bone, bone cement to adhere the prosthesis to the bone, and the femoral stem which is part of a total hip prosthesis. Figure 3 shows the system in a two-dimensional view for simplicity. The human femur used is from a study performed by Koch (Ref. 11). Koch used cross-sections at intervals to demonstrate the actual views showing true size and the regions of cortical bone and cancellous bone. These cross-sections can be found in Appendix A.

The Koch study is one of the most detailed studies done of the human femur. In an effort to avoid confusion, the cross-section numbers specified are identical to the labels Koch presented.

The cement used is of the acrylic type. The cross-sectional thickness of the cement is held constant around the femoral stem at 0.0197 inch (0.5mm); with the exception at the distal end of the stem where a cement plug is formed filling up the region of the cancellous bone remaining in that immediate area.

This cement is commonly used in orthopaedic procedures requiring adhesion of bone to an implant. It is assumed that no gaps or air bubbles are in the cement and that the material properties of the cement are constant throughout. This is a reasonable assumption.

TRUE SCALE

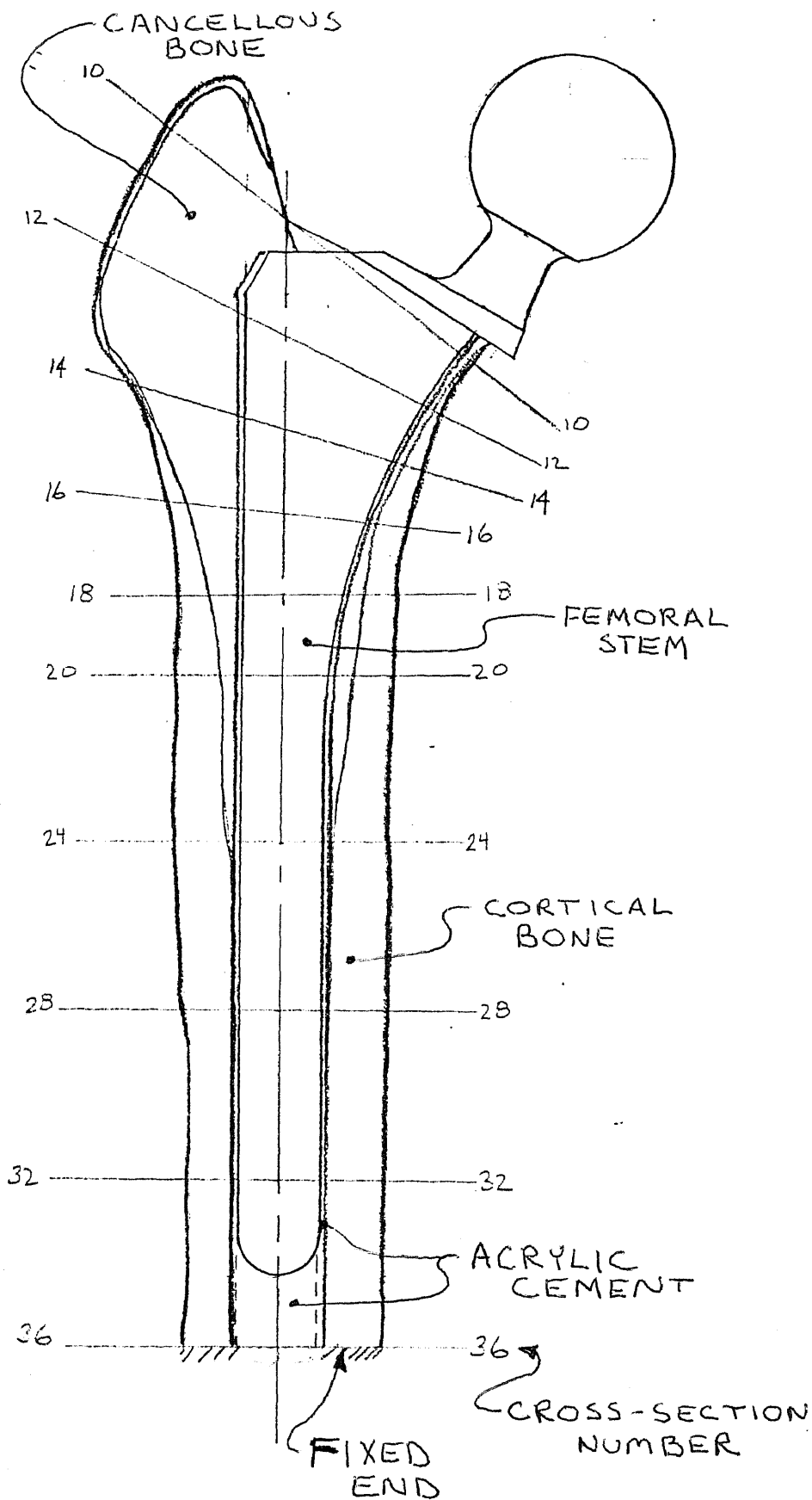

Figure 3.  
Total System  
of study



The dimensions of the femoral component with all of its views is illustrated in Figure 4. The component can be made of either cobalt-chromium alloy or titanium - 6% AL - 4% V alloy.

The material properties of the two alloys and the acrylic bone cement are usually commonly agreed upon. The material properties of bone has encountered great debates. One reason is that no two people's bones are exactly alike. Also, the properties are not constant throughout the femur in either cancellous or cortical bone.

Since the greatest region of cancellous bone is within the greater trochanter, the material properties of this region will be chosen for the average value for all of the cancellous bone. The remaining cancellous bone is extremely soft and does not influence the system greatly. The greatest region of cortical bone is within the lower two-thirds of the system. The properties within this region are fairly consistent (Ref. 11). The remaining cortical bone is extremely thin and does not affect the system to any great extent. Therefore, an average value will be selected for all of the cortical bone using cortical bone properties in the lower two-thirds region. Sih's (Ref. 6) study seems to come closest to average values when compared to numerous other studies.

The material properties are as follows:

- Acrylic bone cement - 300,150 PSI (Ref. 6)
- Cortical bone - 2,575,200 PSI (Ref. 6)
- Cancellous bone - 47,067 PSI (Ref. 6)
- Cobalt-chromium alloy - 30,200,000 PSI (Ref. 16)
- Titanium-6AL-4V alloy - 16,000,000 PSI (Ref. 16)

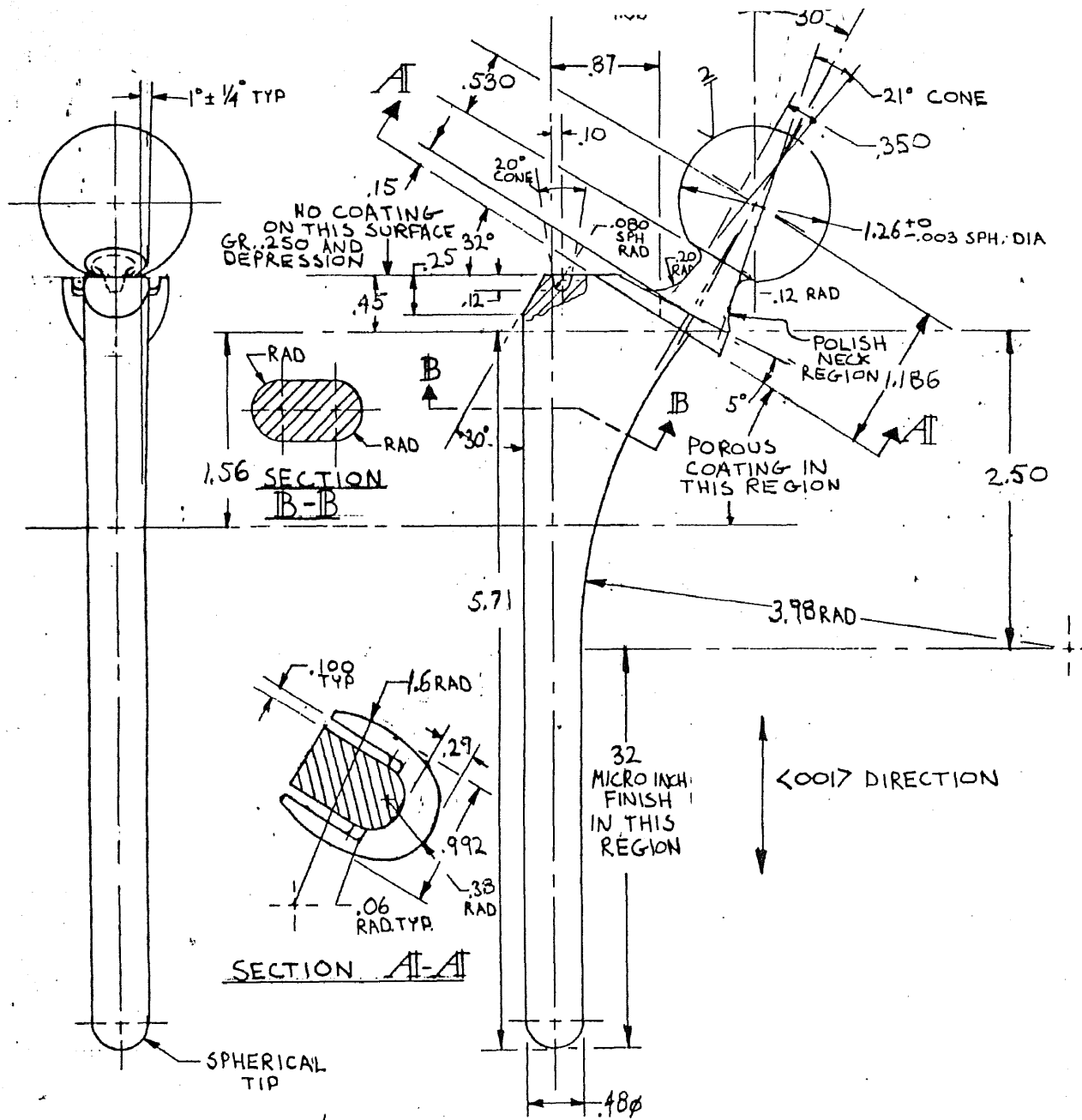

Figure 4.  
 Detail of Femoral Stem  
 Size: Medium Stem  
 Standard Neck  
 (Ref. 13)

The desired model is to be fixed with a zero displacement at all points on cross-section no. 36, except for the inner cement region, which will have no preset limitations placed upon it. This allows to ample displacement of the cement caused by the possible compression from the tip of the stem.

A study performed by Paul (Ref. 12) represents a study of the femur of all forces, including joint and muscle forces complete with moments. This is a representation of all forces throughout a walking cycle. A model that is constructed could be, with respect to geometry, perfect in all regards, but without all of the proper forces accounted for, the model is far less than superior.

Even with the complexity of the calculations and measurements, and the simplifying assumptions made on a analysis of the femur, Paul's study appears to be the best for muscle and ligament forces. There have been numerous studies in one one-legged standing, but this assumes a planar-force system. A study was performed by Rydell (1966) in which strain gages were fitted to the femoral head prosthesis implanted in two patients who had suffered fractures of the neck of the femur. A problem with this study is that the walking speed was slower than normal, (Ref. 12).

Paul measured photographically the three-dimensional configuration of the leg segments during the walking cycle in which the ground-to-foot force actions were measured by a force-plate dynamometer. From these, the resultant forces and moments transmitted between segments were calculated in the same way as by Bresler and Frankel (1950), (Ref. 12).

This study is one that uses the knowledge of the phasic activity of muscles and their anatomical location to aid in determining the tension in relevant ligaments and muscles, including adductors, and joint forces.

Force actions on the system of a walking subject is to be used at four stages in the cycle; at four, nine, forty-one, and fifty-two percent after heel strike. The forces and moments for each percentage is illustrated in Figures 4-7. Note that the forces and moments use a three-dimensional component system.

Figure 8 shows a plot of the hip force against a percentage of a normal cycle of time. This plot is intended to aid the reader in getting a better understanding of what a full walking cycle actually is. The ordinate is a resultant force representation and is only used for graphing purposes.

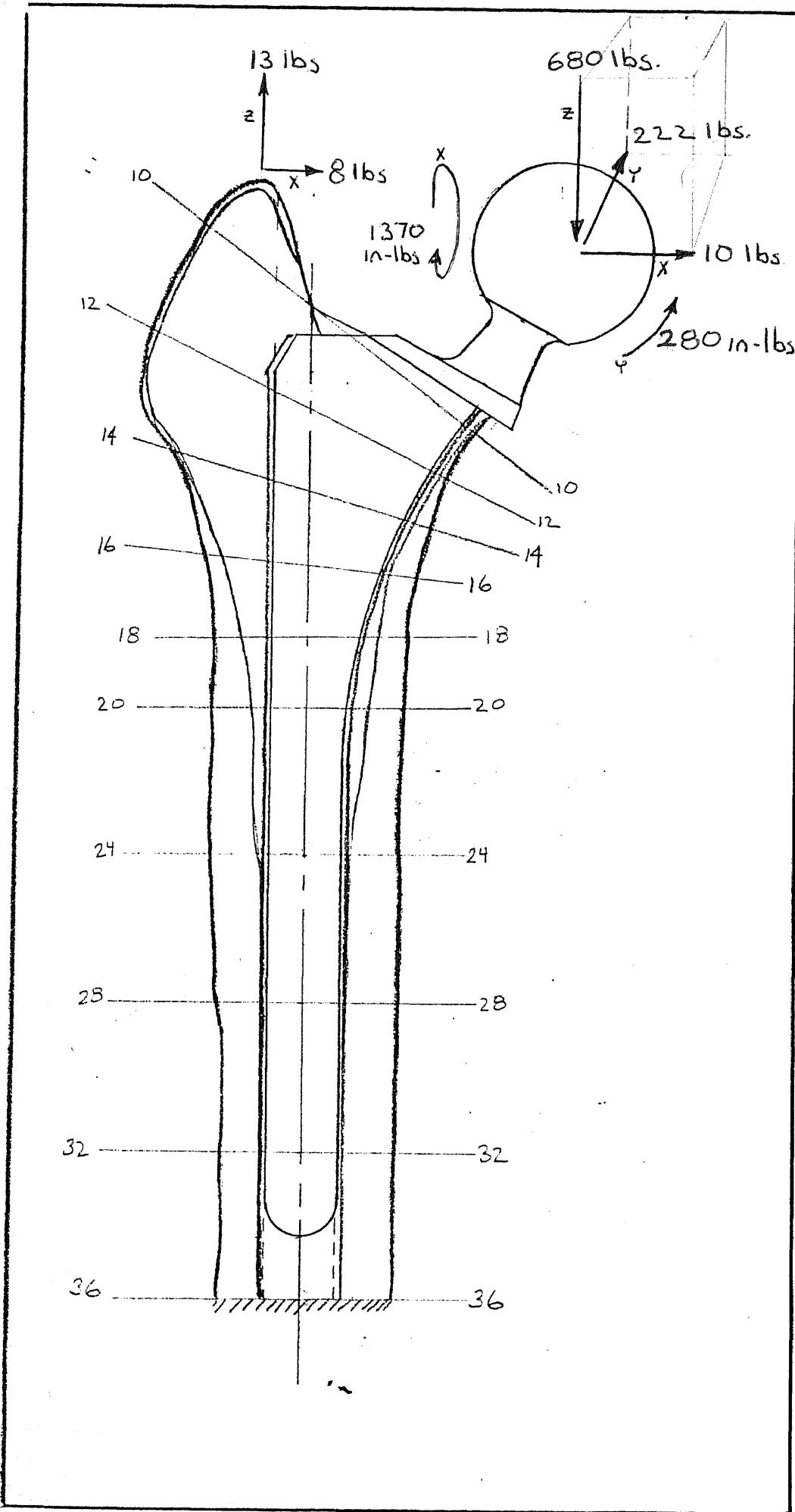

Figure 5.  
 Forces at 4% of  
 Walking Cycle  
 (Ref. 12)

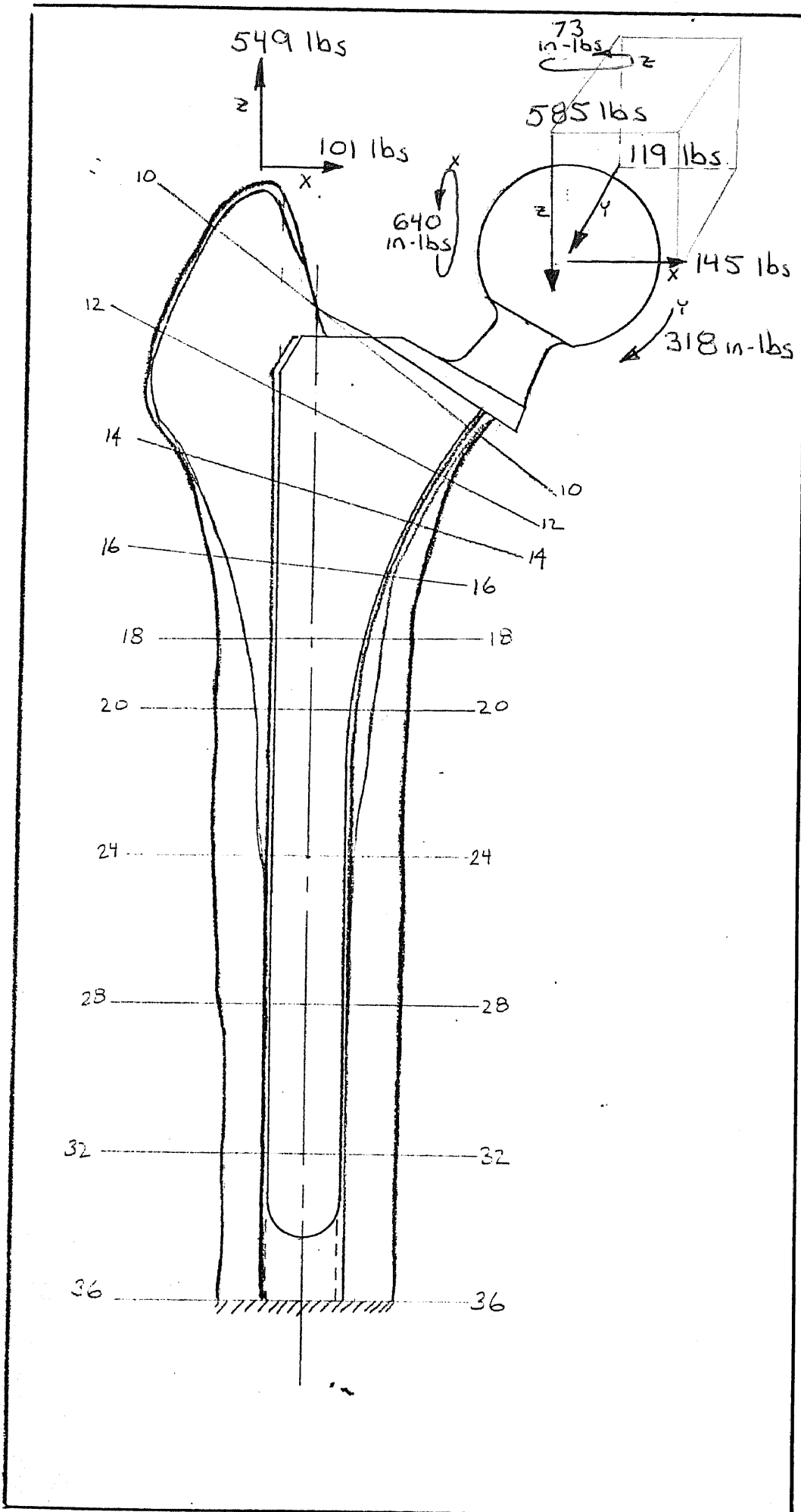

Figure 6.  
 Forces at 9% of  
 Walking Cycle  
 (Ref. 12)

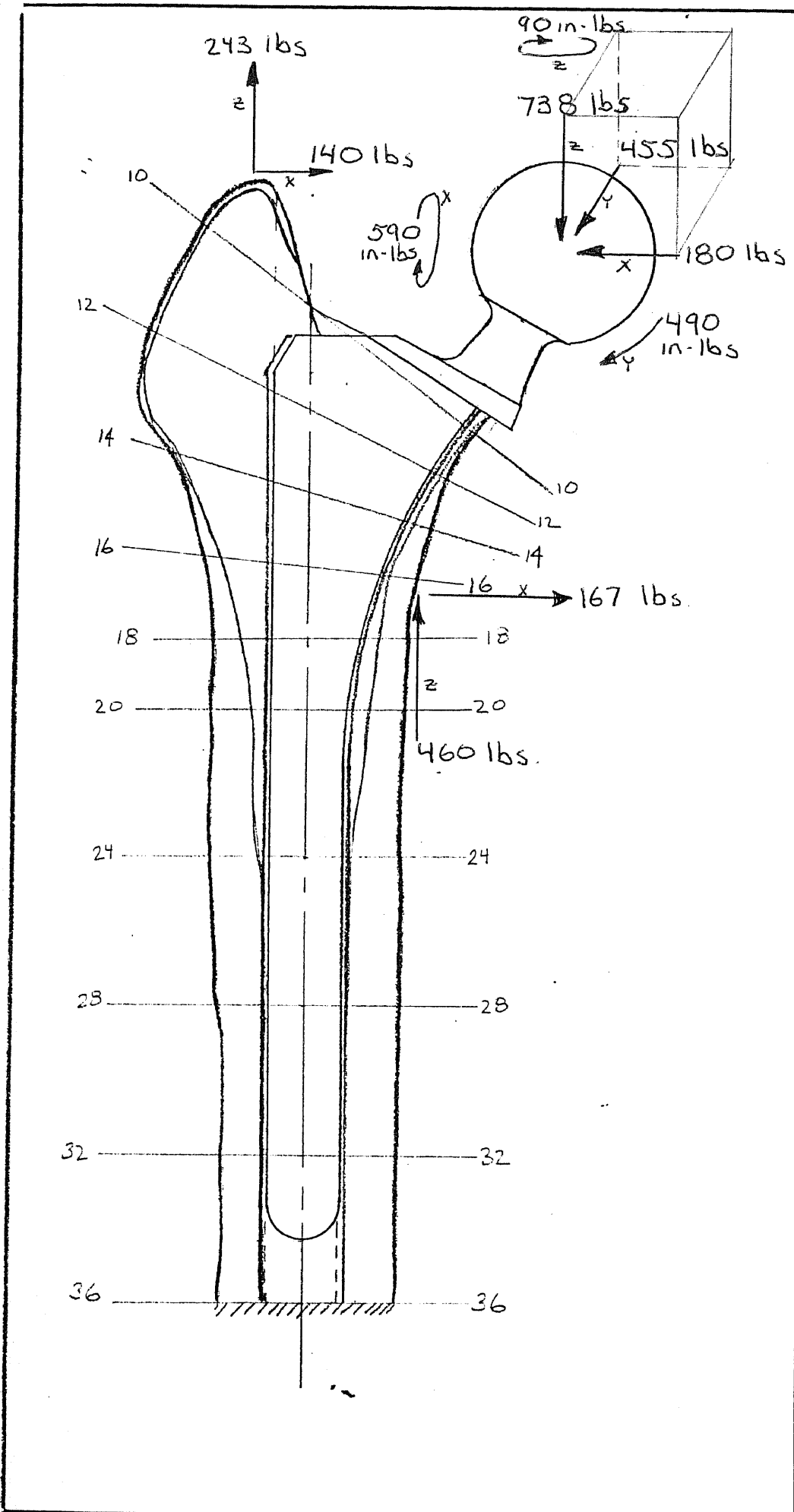

Figure 7.  
 Forces at 41% of  
 Walking Cycle  
 (Ref. 12)

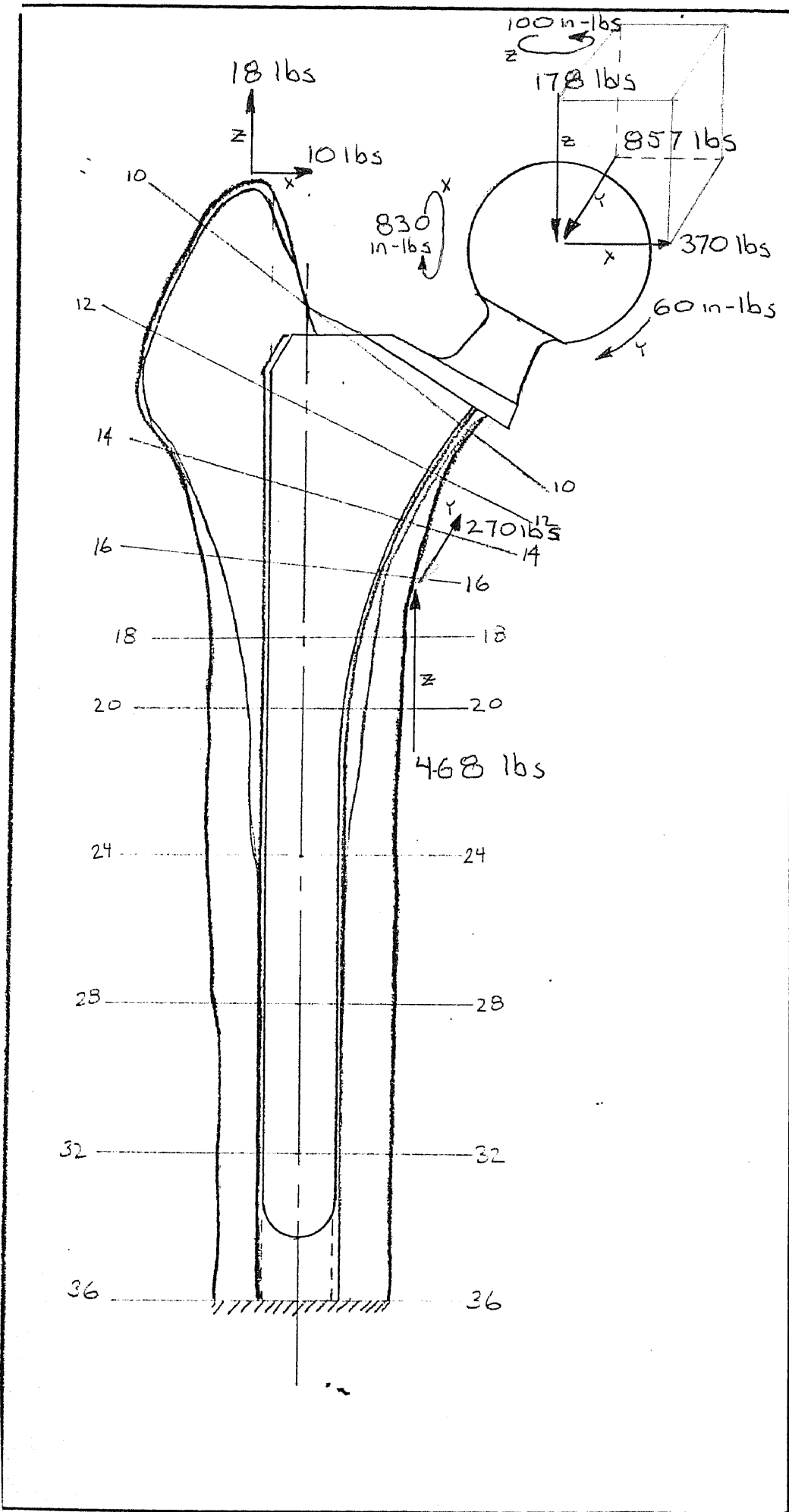

Figure 8.  
 Forces at 52% of  
 Walking Cycle  
 (Ref. 12)



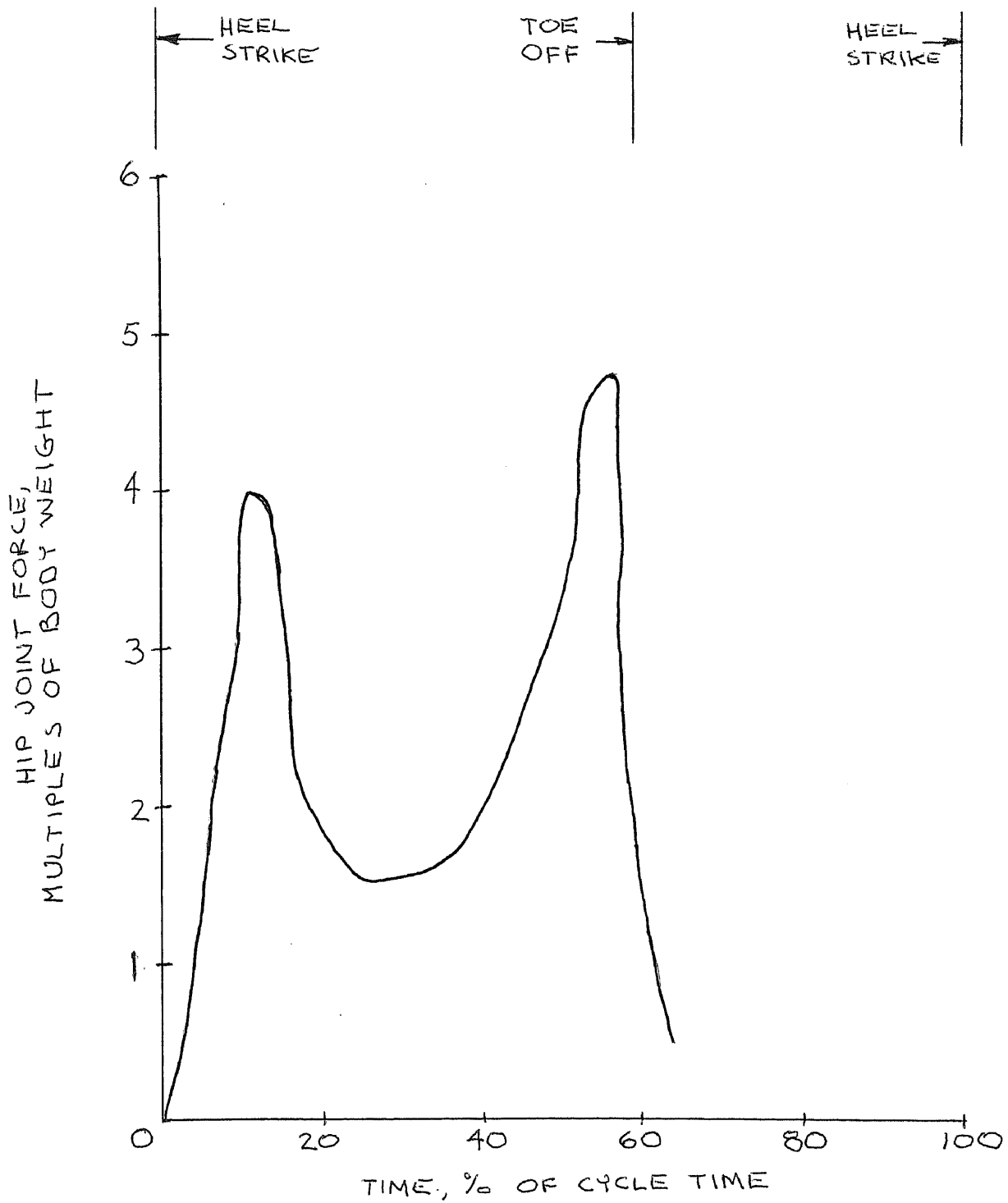

Figure 9.  
 Hip Joint Force During  
 A Normal Walking Cycle  
 (Ref. 14.)

#### IV IMPLANT MATERIALS

The following is offered to educate the reader, and in support of the analysis of the two alloys chosen.

Sophistication of implants and prosthesis in recent years has placed an increasing demand on the materials used. A detailed analysis is necessary and could result in the success of a design and the reduction of failures. For example, problems of wear resistance could mean disaster for an orthopaedic implant.

A type list of constraining requirements could be followed. For this material analysis, these requirements can be divided into three groups (Ref. 15):

1. The compatibility between material and the special environment with which it has to co-exist.
2. The mechanical and physical properties necessary for the desired function.
3. The relative ease of production and supply of the required components.

In other words, it will be said that the material must not:

- a) induce any undesirable and clinically significant changes in the tissues or fluids of the body,
- b) undergo significant changes in either mechanical, physical or chemical properties during the period of implantation such that the implant is unable to function efficiently, and

- c) corrode or degrade such that the products of the deterioration are liberated into the environment, where they may induce local deleterious changes or give rise to harmful systemic effects.

The outstanding specific mechanical and physical properties required for the "ideal" orthopaedic implant (Ref.16) would be a high yield strength, a high tensile strength, good ductility, and high fatigue strength.

To elaborate on the ease of production of the required components, there must be economical methods available to fabricate complex shapes on a mass production basis. Also, the ability to impart appropriate surface finish to the fabricated device, and the ability to achieve good dimensional accuracy and consistency is important (Ref.16).

None of the materials currently in use in orthopaedic implants meets all of these requirements. Thus, the choice of the implant material becomes a matter of optimization, a trading off between the physical, mechanical, and biochemical properties of the various metals (Ref.16).

To date, cobalt-chromium alloys and titanium alloys come closest to the "ideal" optimal material for reasons which will be discussed in detail (Ref. 15, 17).

Perhaps the most suitable metallic material for use in the human body is the cobalt-chromium-molybdenum alloy, usually referred to as the cast cobalt-chromium alloy since it is conventionally fabricated by casting. It is also described by proprietary names such as Vitallium and Vinertia (Ref. 2).

Another type of cobalt-chromium alloy is the cobalt-chromium-nickel-tungsten alloy, referred to as the wrought cobalt-chromium alloy.

The outstanding property of a cobalt-chromium alloy implant is its high degree of corrosion resistance and biocompatibility (Ref. 15).

Corrosion resistance would be included in the biochemical properties of the metal. Corrosion of metallic implants imbedded in the human body may occur by the mechanism of a protective film breakdown of the interface between the implant and the saline solution that surrounds it. Inherently corrosion-resistant materials such as cobalt-chromium base alloys, develop a protective oxide film through a process of surface oxidation or passivation.

Actually, corrosion can be broken down into three sub-topics: galvanic corrosion, crevice corrosion, and stress corrosion. Galvanic corrosion is the most basic form of corrosion affecting surgical implants. It occurs when two dissimilar metals immersed in the same conductive solution set up a transfer of metallic ions. This transfer can also occur in instances where there are slight variations in the composition of the same material throughout a single implant. Therefore, great care must be taken to assure the uniformity of the metal processed.

Gaps and cracks between parts of a multicomponent implant provide sites for crevice corrosion to take place.

When crevice corrosion commences, there is a depletion of local oxygen which further accelerates the corrosion process. The environment that the implant material is placed in, with respect to the quantity of oxygen, is extremely hostile. This can cause rapid breakdown of the passive protective surface layer, leading to rapid corrosion. The passive layers that form over cobalt-chromium alloys tend to be much more stable and therefore more resistant to breakdown.

Metal implants occasionally may be subject to stress corrosion, the result of the combination of mechanical stresses and the corrosive environment in which the implant must exist. Types of stress corrosion include: fretting (stress disrupts the protective layer), stress cracking, and fatigue. Each metal will react depending on the implants environment and type of use (Ref. 16).

Other biochemical properties which are directly related to corrosion and are worthy of mention are local tissue reaction, and systemic toxicity. Corrosion products from a surgical implant may in certain instances cause local tissue reaction, either in the form of fibrous tissue formation, or occasionally an inflammatory cell reaction. Systemic toxicity can be caused by dissolved or corroded particles of certain metals which may exist in trace amounts in impure ores used in formulating the alloy. Cobalt-chromium alloys usually produce no occurrences of tissue reaction or systemic toxicity.

When properly heat-treated following casting, implants

of cobalt-chromium alloy demonstrate good mechanical properties. The reasonably high strength of the cobalt-based alloys is basically due to the cobalt, itself a hard, strong metallic element. Variations in strength of the cast type may be due to the grain size and carbide distribution variations. The small amount of molybdenum reduces the grain size produced on casting and increases the strength accordingly (Ref. 16.) The alloy is, however quite brittle and as more carbides are produced with the increasing carbon content, the alloy becomes even more brittle.

The cobalt-chromium alloys possess excellent abrasion resistance. These alloys are currently the superior choice when a two piece total joint replacement with both bearing surfaces made of metallic materials is desired (Ref. 15).

It should be noted that the specific technique used for the casting of cobalt-chromium alloys is that of investment casting, otherwise known as the lost-wax or precision casting process. This method is used where high dimensional accuracy or extremely intricate shapes are required.

Implants of wrought cobalt-chromium alloy lends itself to fabrication of implants of simple shape with high length-to-width ratio (i.e. pins, rods, wires). This alloy demonstrates improved ductility, mechanical properties comparable to or better than cast products, and good corrosion resistance. The elastic modulus is the highest displayed by current metallic implant materials (Ref.15).

Both types of alloys have been approved by the American Society for Testing and Materials for surgical implant applications. Cast cobalt-chromium-molybdenum alloy has the designated specification ANSI/ASTM F 75. Wrought cobalt-chromium-tungsten-nickel alloy has the designated specification ANSI/ASTM F 90 (Ref.18).

Unalloyed titanium and titanium alloys possess relatively high corrosion resistance to the saline environment of the body. This advantage for unalloyed titanium is offset by the relatively low mechanical properties, including low torsional strength and relatively low wear characteristics that make it unsuitable for metal/metal bearing surfaces. Furthermore, titanium possesses the lowest modulus of elasticity of all the major implant metals, hence, the finished product must be specially designed to provide the required stiffness. Titanium also has caused tissue pigmentation.

An alloy of titanium, 6% aluminum and 4% vanadium (Ti-6Al-4V), shows improved torsional strength and wear characteristics compared to unalloyed titanium. The mechanical properties of this alloy can further be enhanced by heat treatment. Because of the previously stated facts, further discussion will only be presented on the titanium alloy, Ti-6Al-4V.

Ti-6Al-4V alloy can give wear rates equivalent to cobalt alloys. No significant differences were found between these alloys when, with finished passivated surfaces, they

FIGURE 10

COMPARATIVE PHYSICAL AND MECHANICAL PROPERTIES

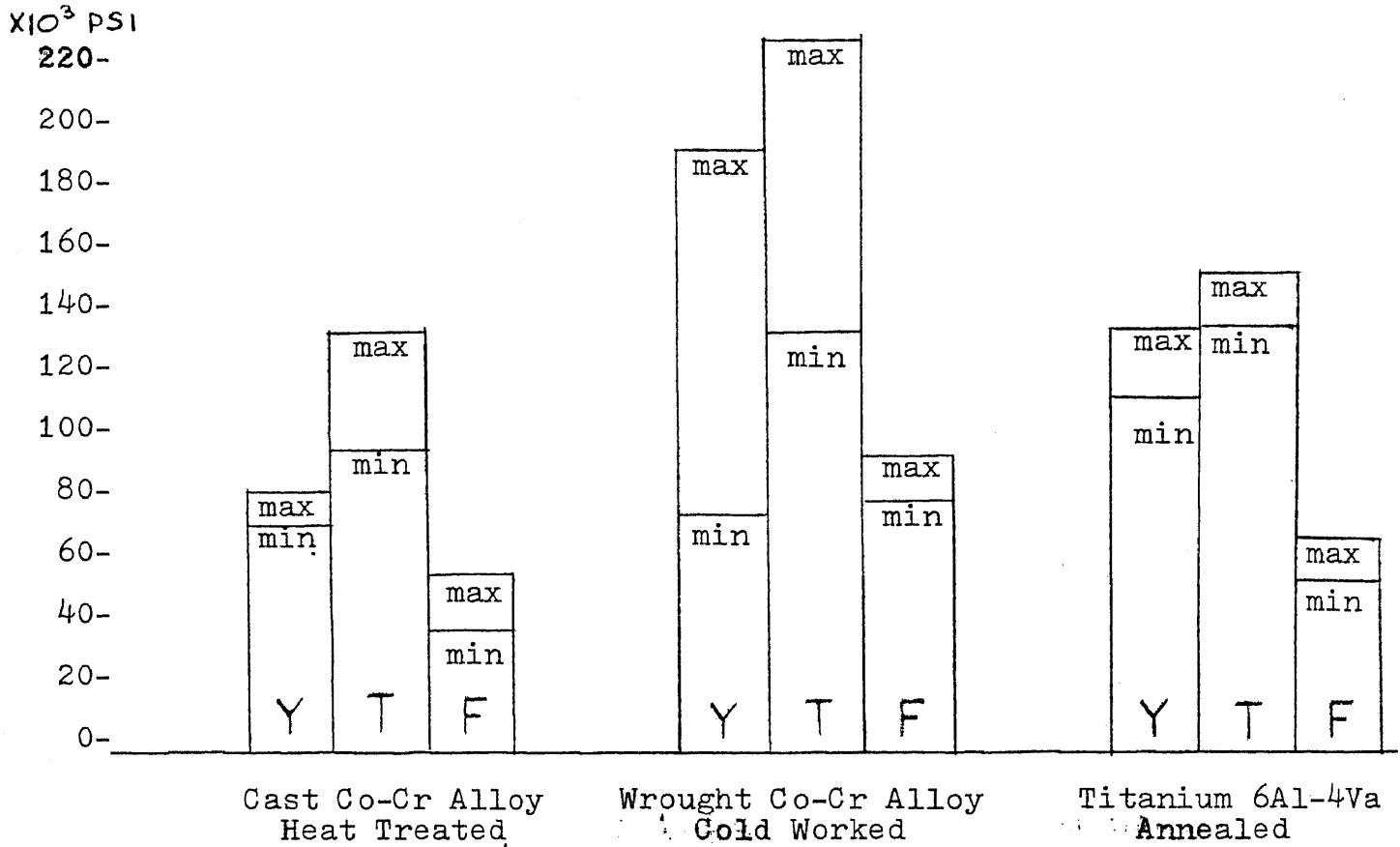

Y - Yield Strength  
 T - Tensile Strength  
 F - Fatigue Strength

(REF. 10)



were abraded against machined ultrahigh molecular weight high density polyethylene. Accordingly, titanium alloy bearing surface total hip prosthesis are commercially available (Ref. 19).

The corrosion resistance of the Ti-6Al-4V alloy is excellent. Titanium is one of the most corrosion resistant engineering materials, being virtually uncorrodable in near neutral solutions, especially those containing the chloride ion, which affects most metals and alloys. Also of great significance is the fact that many titanium alloys display similiar corrosion resistance to the pure metal.

Fretting corrosion of the titanium alloy does not occur too readily. Reformation of the oxide film is extremely rapid and gross corrosion does not occur. It is possible however for small amounts of loose oxide to be released in the surrounding area.

With respect to galvanic corrosion, titanium has a higher potential than other commonly used implant materials and does not, therefore, suffer accelerated attack. There is the possibility of attack on the other metals when in contact with a titanium alloy. For this reason it has been customary to avoid dissimilar metal contact in surgery. However, in recent years, it has been realized that the increases in corrosion rate on coupling some metals is so slight that it does not create any specific problems, and it may be possible to couple two passive metals together. It is clear, for example, that titanium alloys may be coupled to cobalt-chromium alloys

TABLE 1

COMPOSITION OF IMPLANT ALLOYS

<u>Element</u>	<u>Cast Co-Cr Alloy</u>	<u>Wrought Co-Cr Alloy</u>	<u>Titanium 6Al-4Va</u>
hydrogen	-	-	0.0125
carbon	0.35 max.	.05-.15	0.08
oxygen	-	-	0.13
nitrogen	-	-	0.05
aluminum	-	-	5.5-6.5
silicon	1 max.	-	-
<b>titanium</b>	-	-	remainder
vanadium	-	-	3.5-4.5
chromium	27.0-30.0	19.0-21.0	-
manganese	1 max.	2 max.	-
iron	0.75 max.	3 max.	0.25
cobalt	remainder	remainder	-
nickel	2.5 max.	9.0-11.0	-
molybdenum	5.0-7.0	-	-
tungsten	-	14.0-16.0	-

All values are given in percentages.

(REF. 16)

without risk of significantly accelerated corrosion with both metals remaining passive (Ref. 19).

Even though titanium alloys are susceptible in a number of environments to stress corrosion, as of yet there do not appear to be any reports of this type of failure in surgical implants, but this must remain a possibility.

In spite of the extensive clinical use of titanium and its alloys, there are few detailed reports of the titanium-tissue interaction. It is generally concluded that Ti-6Al-4V is extremely well tolerated by the local tissues.

It has been strongly suggested that some patients may be allergic to some implant metals. There is strong evidence that loosening of the total hip prosthesis may be initiated by a hypersensitivity reaction to the implant, indicating that metal sensitivity may be an important factor in biocompatibility. However, all the recorded cases relate to stainless steel or cobalt-chromium alloys, which are known sensitizers in relation to skin. There is no evidence to suggest that titanium can be a sensitizer or that it causes such hypersensitivity effects, and indeed this metal should be preferred should a patient be suspected of being sensitive to metals.

Titanium appears to have a very low toxicity and is well tolerated by the human body. Like titanium, aluminum occurs in only very low concentrations, with no evidence that it is an essential trace element. Toxicity arising from ingested aluminum is low. Vanadium, on the other hand, is an essential trace element being implicated in the mineralization of bones and teeth. It is not regarded as a particular toxic element (Ref. 19).

In situations where the metal articulates against cartilage or bone, the precise wear characteristics of the prosthetic material have not been considered too important, even though some wear does take place. The low specific gravity of titanium has been an advantage, and many prefer the lighter prosthesis. Other advantages to many of the major implant materials are the resistance to fretting corrosion and the superior resistance to corrosion fatigue.

An important advantage that the titanium alloy has compared with the cobalt-chromium alloys is that the material is substantially less rigid. With respect to a femoral stem, the increased flexibility results in lower stem loading reducing stem stresses, and a higher loading of the bone, reducing atrophy (Ref.20).

The titanium, 6% Al, 4% V extra-low interstitial alloy annealed has been approved by the American Society for Testing and Materials for surgical implant applications. The alloy has the designated specification ANSI/ASTM F 136 (Ref.18).

## V ANSYS AND STIF45 ELEMENT MODULE

The ANSYS computer program is a large-scale, general purpose computer program for the solution of several classes of engineering analysis. Analysis capabilities include static and dynamic, elastic, plastic, creep, and swelling, puckling; small and large deflections; steady state and transient heat transfer, fluid and current flow.

The matrix displacement method of analysis based upon finite element idealization is employed throughout the program. Loading on the structure may be forces, displacements, pressures, temperatures or arbitrary functions of time for linear and nonlinear dynamic analysis.

The ANSYS program uses the wave-front direct solution method for the system of simultaneous linear equations developed by the matrix displacement method, with no limit on the number of elements used in an analysis (Ref.21).

The input data for the ANSYS program incorporates a preprocess or (PREP 7) which contains powerful mesh generation capabilities. PREP 7 prepares all data necessary for the solution. The total generation is done with results stored on various files. The PREP 7 routine consists of several modules with each module performing a different operation and containing a unique set of commands.

The element used to construct the model is STIF45 which is three-dimensional. The element is defined by eight nodal points having three degrees of freedom at each

node with translations in the nodal X, Y, and Z direction. Orthotropic material properties correspond to the element coordinate direction.

The element theory is based upon a formulation which includes incompatible displacement shape, as described in Ref.22. A 3x3x3 lattice of integration points is used with the numerical (Gaussian) integration procedure. When the stiffness matrix is formed with shape functions, the shape functions are as follows (Ref.23):

$$\begin{aligned}
 4 = & 1/8(U_I(1-s)(1-t)(1-r) \\
 & +U_J(1+s)(1-t)(1-r) \\
 & +U_K(1+s)(1+t)(1-r) \\
 & +U_L(1-s)(1+t)(1-r) \\
 & +U_M(1-s)(1-t)(1+r) \\
 & +U_N(1+s)(1-t)(1+r) \\
 & +U_O(1+s)(1+s)(1+r) \\
 & +U_P(1-s)(1+s)(1+r))
 \end{aligned}$$

Where  $U_i$  is typical displacement at node i, U is the total typical displacement, and r,s, and t are locations of nodes within the generated local coordinate system.

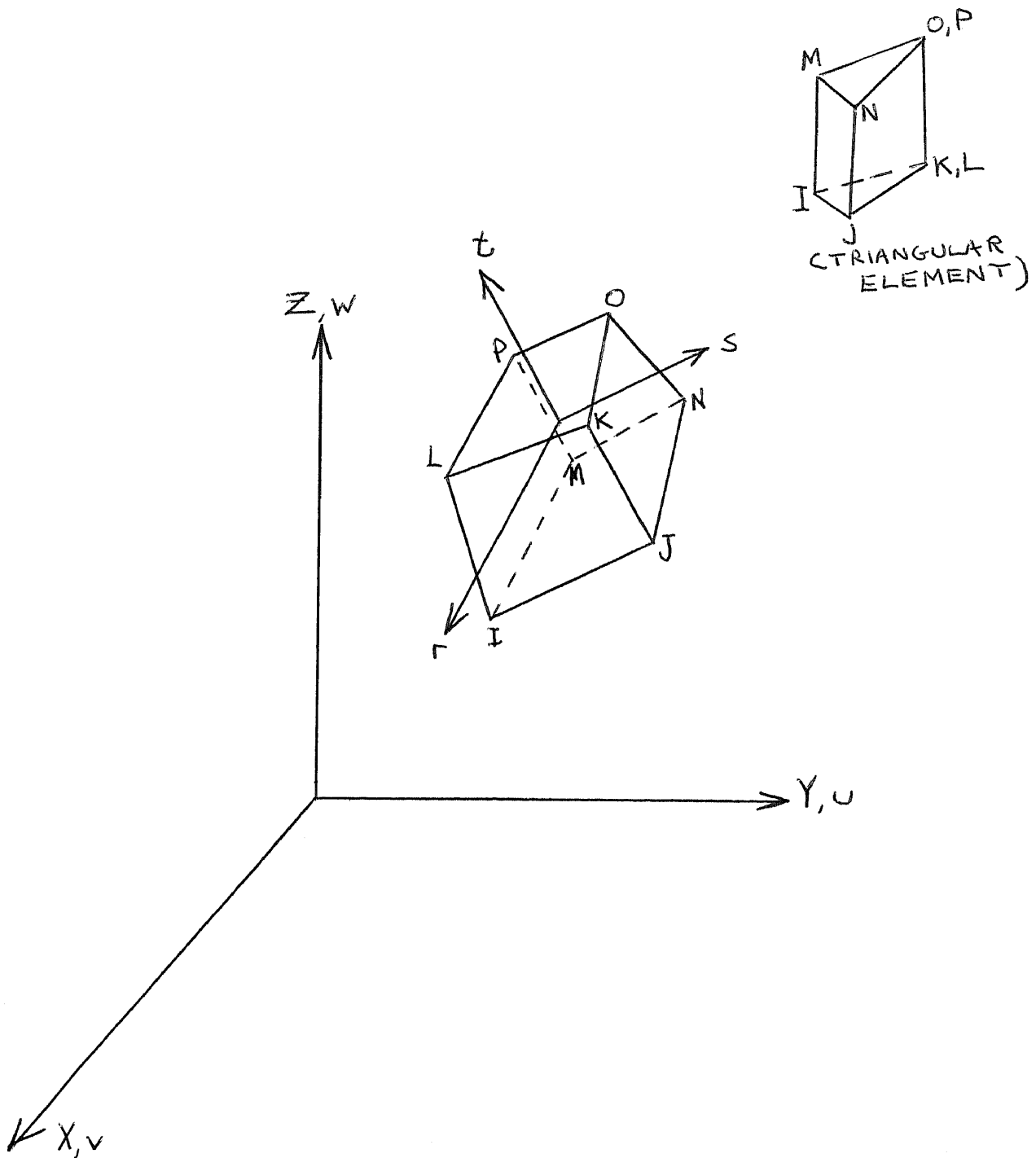

Figure 11  
 The STIF45 Element  
 (Ref. 23)

## VI FORMULATION OF MODEL

The system described in Chapter III was formulated with the use of commands found in the Users Manual (Ref.21). Basically ten nodes are placed thirty-six degrees apart at each of the cross-sectional interfaces. There is a maximum of four interfaces; implant stem to cement, cement to cancellous bone, cancellous bone to cortical bone, and cortical bone to the system surrounding environment. Obviously, where a cross-section contains no cancellous bone, only three interfaces are used. This ten node interface relationship is used from the bottom of the stem to the uppermost portion of the femur.

Between every two cross-sectional planes, thirty elements were constructed if no cancellous bone is present. If cancellous bone is present, forty elements are used, ten for constructing the region of cancellous bone.

Random elements are constructed in the region of the greater trochanter, and, in the region of the neck and ball of the prosthesis, the coordinate system is rotated in an effort to create symmetry for element generations.

For every element, the module used, STIF45, had to be specified with the material reference number.

After the complete model is specified, forces are applied to certain nodes, and material properties are entered.

Since, for this model, the bottom most cross-sectional area is fixed, the displacement of all nodes at that cross-



section, nodes 1 to 30, is set to zero, leaving the inner cement region with no limitations.

The following is a explanation of the method used to generate nodes 1 to 30:

1. It is desired to have ten nodes,  $36^{\circ}$  apart, at each interface. In cross-section no. 36, there are three interfaces, stem to cement, cement to cortical bone, and cortical bone to the environment.

2. Since the stem at this cross-section is circular, and since the axis of the model goes thru its center, cylindrical geometry is established about the axis. Therefore, the coordinate system is set to handle cylindrical coordinates having the origin in the center of the stem at this cross-section. The command for coordinate system is described as follows:

```
CSYS,KCN
      ACTIVATES AN ALREADY DEFINED COORDINATE SYSTEM
      KCN - NUMBER OF COORDINATE SYSTEM TO BE ACTIVATED
            0 - GLOBAL CARTESIAN
            1 - CYLINDRICAL
            2 - SPHERICAL
            N - REFERENCE NUMBER OF USER DEFINED SYSTEM
```

The command entered is:

```
CSYS,1
```

3. The first node is desired to be set at the  $0^{\circ}$  and at half the diameter of the stem or 0.2375 inch. The command for nodal placement is described as follows:

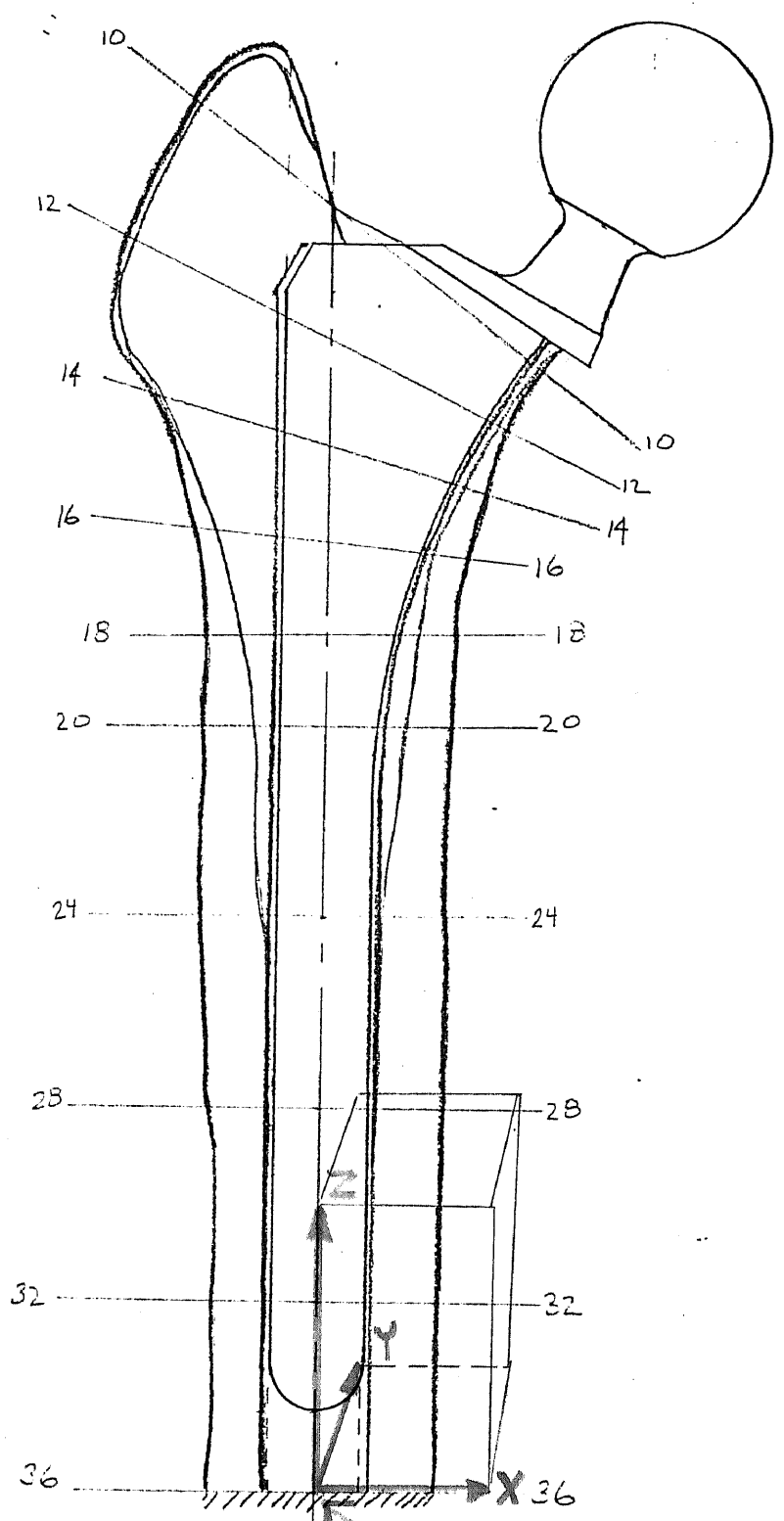

Figure 12.  
 Cartesian Coordinate  
 System with  
 Origin

CENTER OF  
 CROSS SECTION IS  
 ORIGIN. (0, 0, 0)

N,NODE,X,Y,Z,THXY,THYZ,THXZ

DEFINES A NODE IN THE CURRENT COORDINATE SYSTEM

NODE - NODE NUMBER TO BE ASSIGNED  
X,Y,Z - NODE LOCATION IN THE CURRENTLY ACTIVE COORDINATE  
SYSTEM (R,THETA,Z FOR CYLINDRICAL,R,THETA,PHI  
FOR SPHERICAL OR TOROIDAL)  
THXY, - NODAL COORDINATE ROTATION ANGLES  
THYZ,  
THXZ

Recalling the cylindrical system which uses R as the radius. Theta as the angle, and Z, which in this model, is the vertical displacement from the origin. Therefore, for node 1, the command entered is:

N,1,.2375,0,0

4. Since, at this cross-section, the stem is a circle, all ten nodes will have the same radius and Z location with only Theta changing. To have ten nodes in a 360° circle, each node must be 36° apart. The command for the generation of these nodes is described as follows:

NGEN,ITIME,INC,NODE1,NODE2,NINC,DX,DY,DZ,SPACE

GENERATES ADDITIONAL NODES FROM A GIVEN PATTERN

ITIME, - DO THIS GENERATION OPERATION A TOTAL OF ITIME,  
INC - INCREMENTING ALL NODES IN THE GIVEN PATTERN BY INC  
EACH TIME (INC DEFAULTS TO 0)  
NODE1, - BEGINNING AND ENDING NODE NUMBERS DEFINING THE  
NODE2 - PATTERN TO BE REPEATED (NODE2 DEFAULTS TO NODE1)  
NINC - INCLUDE ALL NODES FROM NODE1 TO NODE2 IN STEPS  
OF NINC (DEFAULTS TO 1)  
DX,DY, - NODE LOCATION INCREMENTS IN THE CURRENTLY ACTIVE  
DZ - COORDINATE SYSTEM (DR,DTHETA,DZ FOR CYLINDRICAL,  
DR,DTHETA,DPHI, FOR SPHERICAL OR TOROIDAL)  
SPACE - SCALE GENERATED NODE PATTERN BY THIS VALUE BEFORE  
APPLYING NODE LOCATION INCREMENTS (DEFAULT IS 1)

The command entered is:

NGEN,10,1,1,1,1,0,36,0

Nodes 1 to 10 are now generated.

Nodes 1-10, Stem Canal  
 Nodes 11-20, Cement  
 Nodes 21-30, Cortical Bone

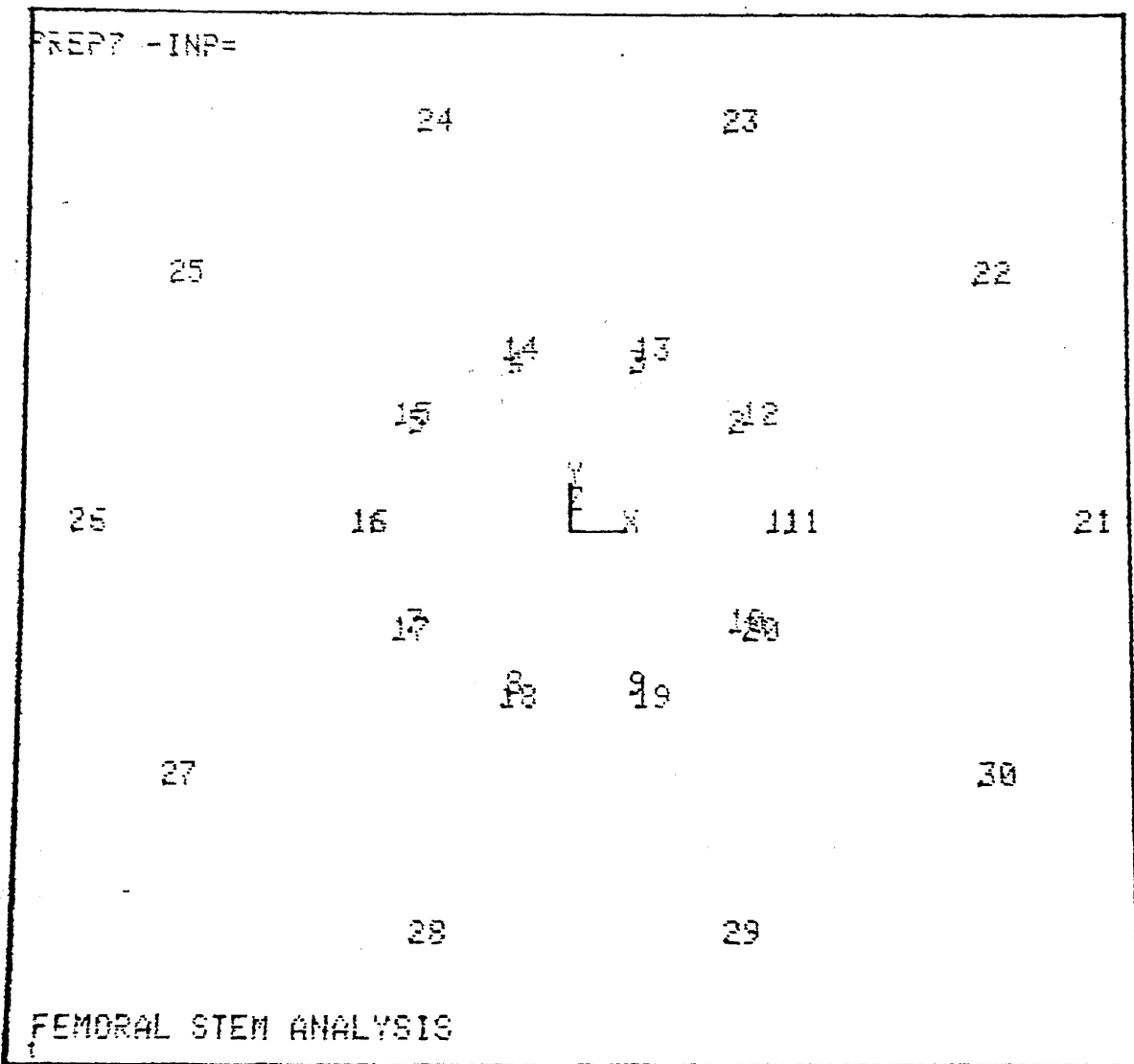

ANSYS  
 4/10/84  
 14.6271  
 PREP7 NODES  
 NMAX=38

AUTO SCALING  
 YU=-1  
 ZU=2  
 DIST=.66

Figure 13.  
 Placement of Nodes in  
 Cross-section 36

5. The cement to bone interface nodes are symmetrical about the axis of the cement to stem interface with only the radius changing. The cement thickness is 0.0197 inch. To generate the nodes at this interface, the command entered is:

```
NGEN,2,10,1,10,1,.0197,0,0
```

Nodes 11 to 20 are generated.

6. The cortical bone to the environment interface nodes are also symmetrical about the axis of the cement to stem interface with only the radius changing. The difference between the radius of the stem and the radius of the bone is 0.3625 inch. To generate the nodes at this interface, the command entered is:

```
NGEN,2,20,1,10,1,.3625,0,0
```

At this point in the program, nodes 1 to 30 are generated. Next the nodes are generated for the cross-sections remaining. Recalling the system to be modeled, symmetry about the axis is not possible for most of the cross-sections.

When all nodes are completed, elements are entered using the following two commands:

```
E,I,J,K,L,M,N,O,P
```

```
DEFINES ELEMENT CONNECTIVITY
```

```
I,J,K, - NUMBER ASSIGNED TO NODE 1 (FIRST NODE), J  
L,M,N, (SECOND NODE), ETC.  
O,P
```

```
EGEN,ITIME,INC,IEL1,IEL2,IEINC,
```

```
GENERATES ADDITIONAL ELEMENTS
```

```
ITIME, - DO THIS GENERATION OPERATION A TOTAL OF ITIME,  
INC INCREMENTING ALL NODES IN THE GIVEN PATTERN  
BY INC. INC DEFAULTS TO 1
```

IEL1, - BEGINNING AND ENDING ELEMENT NUMBERS DEFINING  
 IEL2, THE PATTERN TO BE REPEATED. INCLUDE ALL ELEMENTS  
 IEINC FROM IEL1 TO IEL2 IN STEPS OF IEINC. IEL2  
 DEFAULTS TO IEL1. IEINC DEFAULTS TO 1.  
 IF IEL1 IS NEGATIVE, USE THE PREVIOUS (-IEL1)  
 ELEMENTS AS THE PATTERN TO BE REPEATED.

To generate the nodes and elements in the greater  
 trochanter, and the neck and ball of the prosthesis, a local  
 coordinate system was desired so there could be a change in  
 the origin and central axis. The following command is used:

```

LOCAL,KCN,KCS,XC,YC,ZC,THXY,THYZ,THXZ,PARAM
DEFINES A LOCAL COORDINATE SYSTEM (ALTERNATE)

KCN   - ARBITRARY NUMBER ASSIGNED TO THIS COORDINATE
        SYSTEM. MUST BE GREATER THAN 10 (MAX. 40)
KCS   - COORDINATE SYSTEM TYPE
        0 - CARTESIAN
        1 - CYLINDRICAL
        2 - SPHERICAL
        3 - TOROIDAL
XC,   - GLOBAL CARTESIAN COORDINATES OF THE ORIGIN
YC,   OF THIS COORDINATE SYSTEM
ZC
THXY, - ROTATION ANGLES OF THIS LOCAL
THYZ, COORDINATE SYSTEM RELATIVE TO THE
THXZ  GLOBAL CARTESIAN COORDINATE SYSTEM
PARAM - PARAMETER FOR THIS COORDINATE SYSTEM TYPE
  
```

To get the desired zero displacement at Nodes 1 to 30  
 so the model will have a fixed end, the command used is des-  
 cribed as follows:

```

D,NODE,LAB,DISP,CDISP,NEND,NINC,LAB2,...LAB6
SPECIFIED DISPLACEMENTS

NODE   - NODE NUMBER AT WHICH DISPLACEMENT IS TO BE SPECIFIED
LAB    - DISPLACEMENT DIRECTION OR DEGREE OF FREEDOM
        (VALID LABELS ARE ALL,UX,UY,UZ,ROTX,ROTY,ROTZ.
        LAB=ALL IS USED TO SPECIFY DISPL. AT ALL VALID
        DEGREES OF FREEDOM FOR THE SELECTED ELEMENT TYPES.
DISP   - VALUE OF DISPLACEMENT
CDISP  - IMAGINARY PART OF DISPLACEMENT VALUE (KAN=6 ONLY)
NEND,  - USED TO NAME ADDITIONAL NODES WHERE SAME DISPL.
NINC   IS SPECIFIED. DISPL. SPECIFIED FROM NODE TO NEND
        WITH NODE INCREMENTS OF NINC
  
```

LAB2 - OTHER LABELS AT WHICH SAME DISPLACEMENT IS SPECIFIED  
TO LAB6

The command entered is:

D,1,ALL,0,0,30,1,0

The material properties of each element are set prior to the construction of the element with each material given a specific reference number. The following identifies each material:

Material 1 = acrylic cement  
300,150 PSI

Material 2,4= cortical bone  
2,575,200 PSI

Material 3 = cancellous bone  
47,067 PSI

Material 5 = cobalt-chromium alloy  
30,200,000 PSI  
or  
titanium-6AL-4V alloy  
16,000,000 PSI

The forces at the four percentages of the walking cycle use the following command:

F,NODE,LAB,FORCE

SPECIFIED FORCE AT DEGREES OF FREEDOM

LAB - DIRECTION OF FORCE VALID LABELS ARE  
FX,FY,FZ,MX,MY,MZ

FORCE - FORCE OR MOMENT VALUE

At four percent of the walking cycle, the commands entered are:

F,3011,FX,10  
F,3011,FY,222  
F,3011,FZ,-680  
F,3011,MY,-280  
F,3011,MX,1370  
F,911,FZ,13  
F,911,FX,8

At nine percent of the walking cycle, the commands entered are:

```
F,3011,FX,145
F,3011,FY,-119
F,3011,FZ,-585
F,3011,MX,-640
F,3011,MY,318
F,3011,MZ,-73
F,911,FX,101
F,911,FZ,549
```

At forty-one percent of the walking cycle, the commands entered are:

```
F,3011,FX,-180
F,3011,FY,-455
F,3011,FZ,-738
F,3011,MX,590
F,3011,MY,490
F,3011,MZ,90
F,911,FX,140
F,911,FZ,243
F,140,FX,167
F,140,FZ,460
```

At fifty-two percent of the walking cycle, the commands entered are:

```
F,3011,FX,370
F,3011,FY,-857
F,3011,FZ,-178
F,3011,MX,830
F,3011,MY,60
F,3011,MZ,-100
F,911,FX,10
F,911,FZ,18
F,140,FY,270
F,140,FZ,468
```

Only the major commands have been detailed. For further information on many of the minor commands and the commands for plotting, filing data, checking, and execution, the reader should consult the ANSYS users manual, Ref.21.



## VII THE MODEL

The following pages represent the computer graphics display of the model, viewing at fifty element intervals with the last figures showing the total model with all elements and nodes. Note that the proper scaling factors are documented on the figures. At the top of each figure is a detailed description of what is shown. Note that cross-section is denoted as C.S. where the specific cross-section number is displayed in Figure 3, as is the material regions.

In Appendix C is the Table of Nodes and the Table of Elements. With this, the exact model can be reproduced.

Elements 1 to 30, cement between  
C.S.24 and 36  
Elements 31 to 50, cortical bone  
C.S.28 and 36

REP7 -INP=

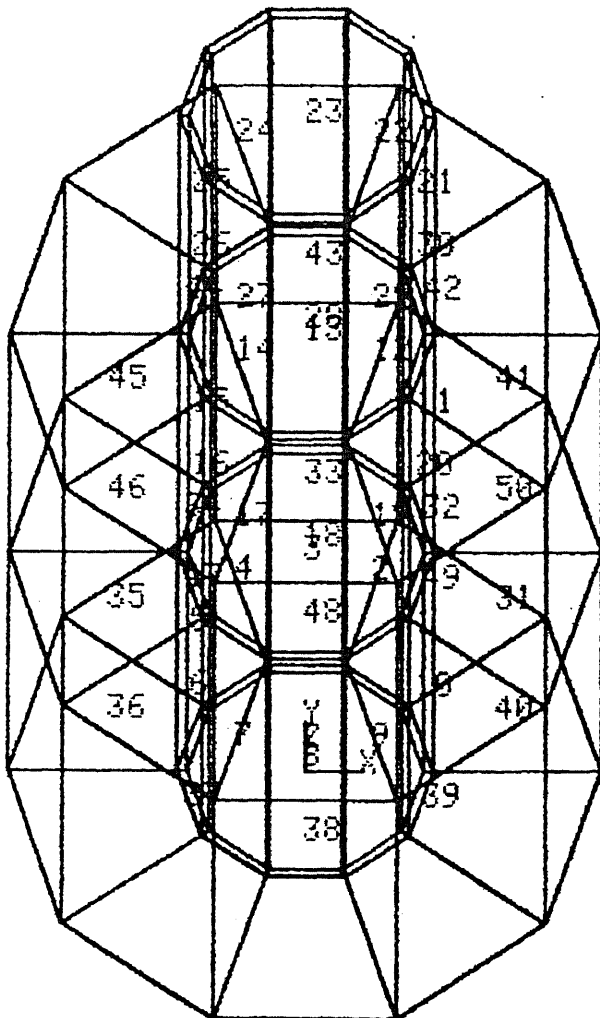

ANSYS  
3/23/84  
10.3901  
PREP7 ELEMENTS  
EMAX=50  
ENUM=1

AUTO SCALING  
YU=-1  
ZU=2  
DIST=1.14  
YF=-.0978  
ZF=1.37

FEMORAL STEM ANALYSIS

Figure 14.  
Elements 1 to 50

Elements 51-60, cortical bone between  
C.S.24 and 28  
Elements 61-100, cement between  
C.S.24 and 14

PREP7 -INP=

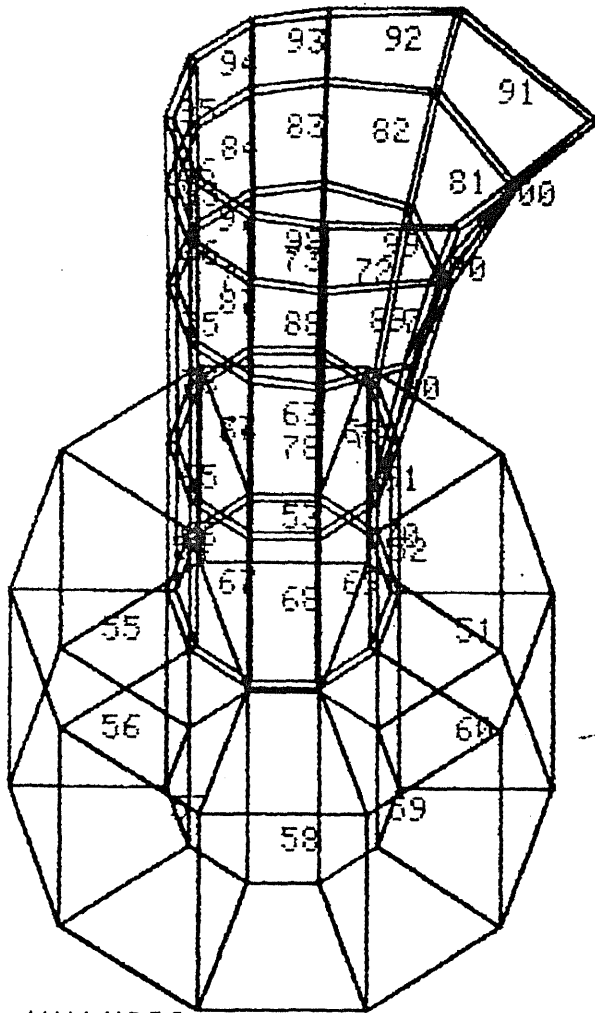

ANSYS  
3/23/84  
10.4267  
PREP7 ELEMENTS  
EMIN=51  
EMAX=100  
ENUM=1

AUTO SCALING  
YU=-1  
ZU=2  
DIST=1.26  
XF=.0499  
YF=-.0866  
ZF=3.58

FEMORAL STEM ANALYSIS

Figure 15.  
Elements 51-100

Elements 101 to 120, cement between  
C.S.14 and 10  
Elements 121 to 150, cancellous bone between  
C.S.28 and 18

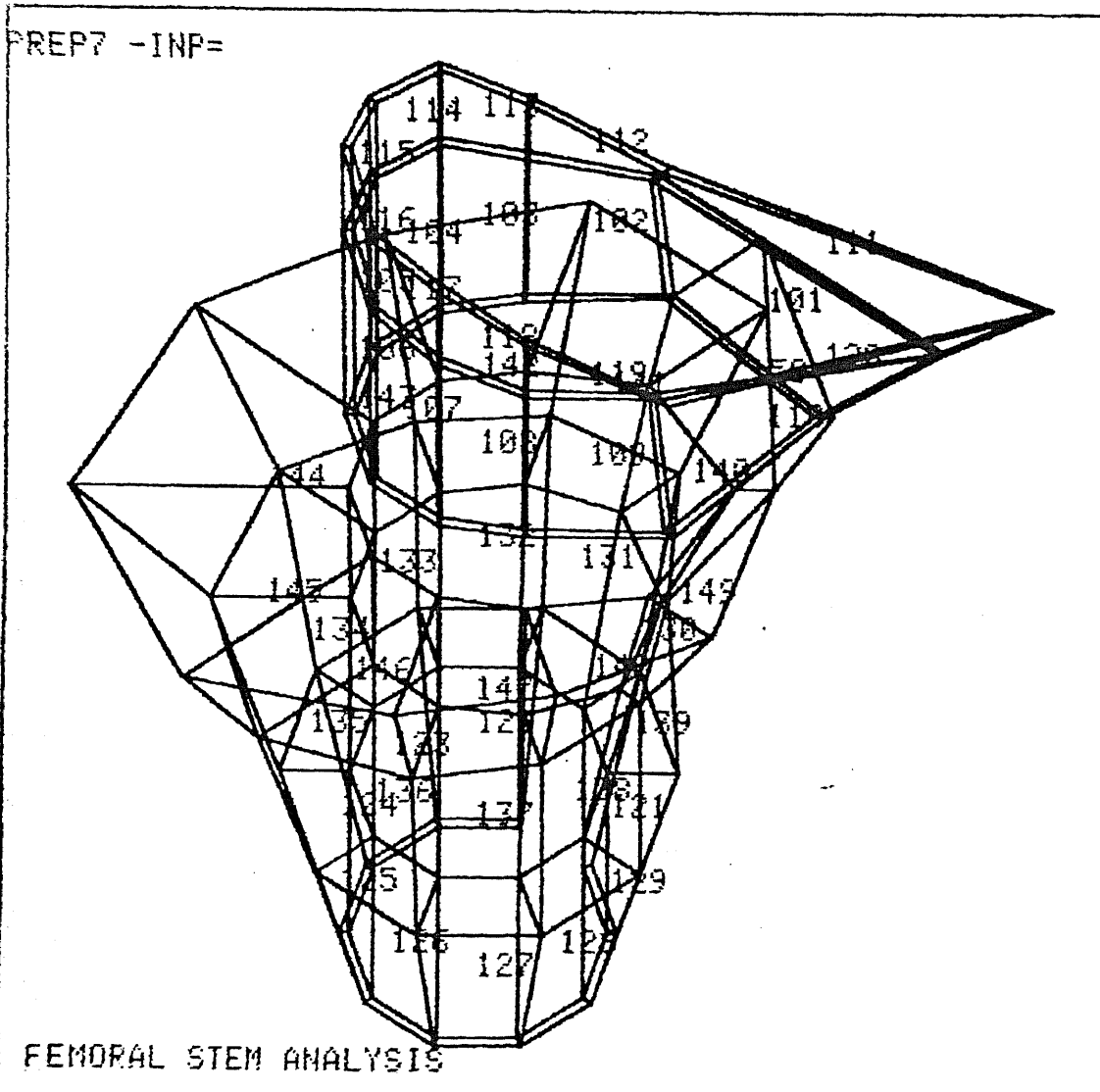

ANSYS  
3/23/84  
10.4510  
PREP7 ELEMENTS  
EMIN=101  
EMAX=150  
ENUM=1  
  
AUTO SCALING  
YU=-1  
ZU=2  
DIST=1.12  
XF=.165  
ZF=4.75

Figure 16  
Elements 101 to 150

Elements 151 to 180, cancellous bone  
  between C.S.18 and 12  
Elements 181 to 200, cortical bone  
  between C.S.28 and 20

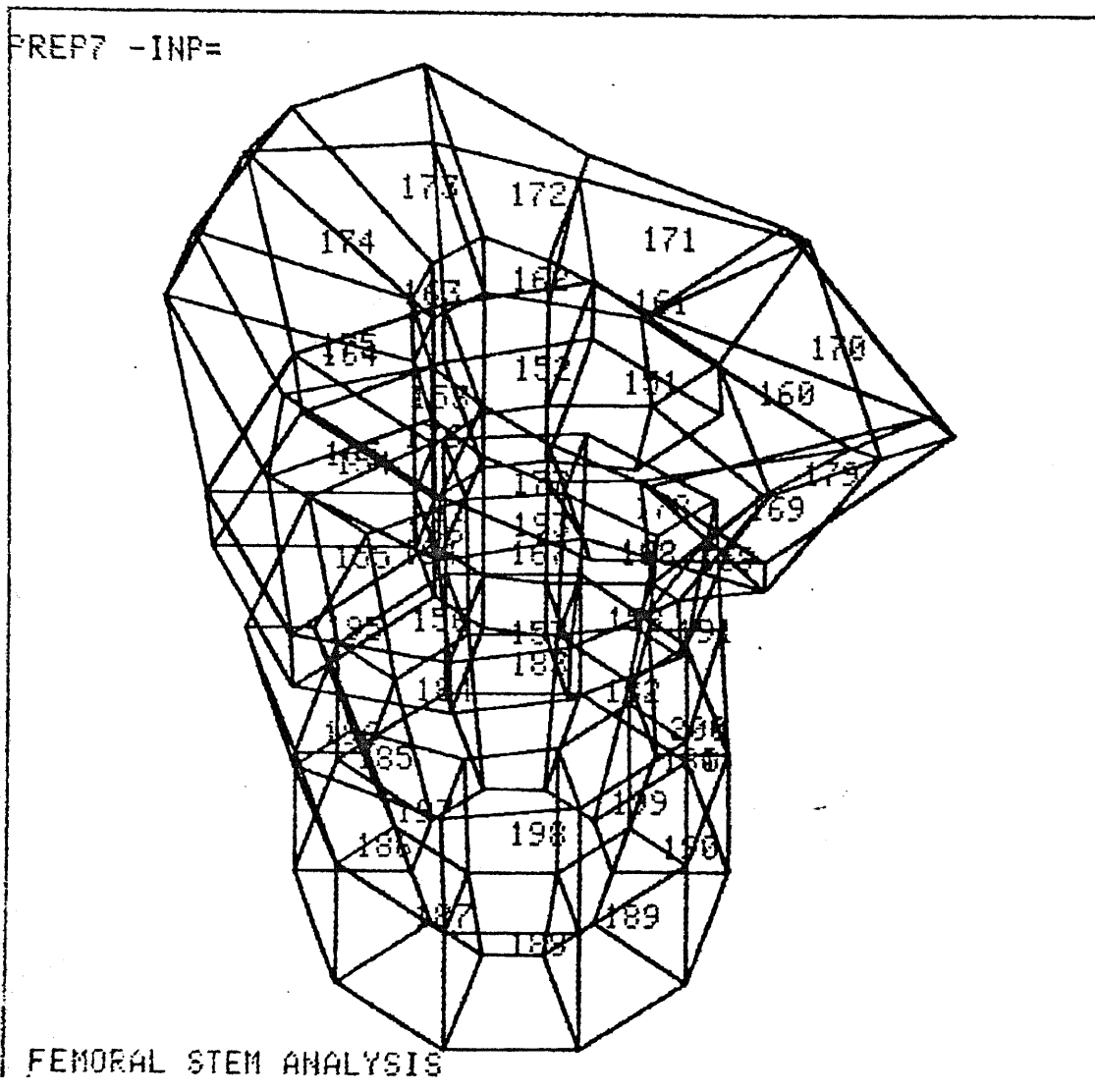

ANSYS  
3/23/84  
10.4950  
PREP7 ELEMENTS  
EMIN=151  
EMAX=200  
ENUM=1  
  
AUTO SCALING  
YU=-1  
ZU=2  
DIST=1.54  
XF=.13  
YF=.0169  
ZF=4.96

Figure 17.  
Elements 151-200

Elements 201 to 240, cortical bone between  
 C.S.20 and 12  
 Elements 241 to 250, cement between  
 C.S.10 and neck of  
 Prosthesis

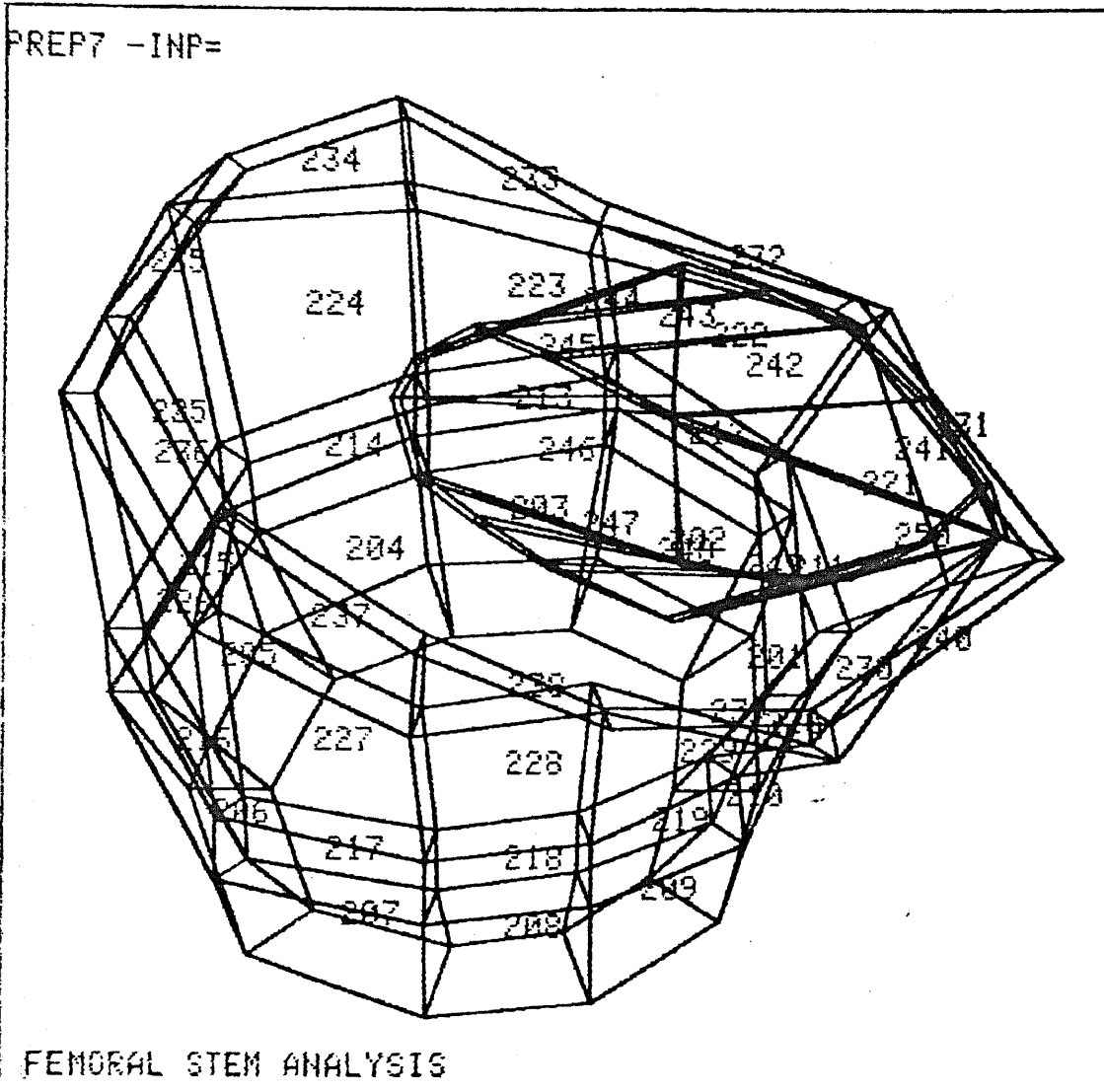

ANSYS  
 3/23/84  
 10.5219  
 PREP7 ELEMENTS  
 EMIN=201  
 EMAX=250  
 ENUM=1  
 AUTO SCALING  
 YU=-1  
 ZU=2  
 DIST=1.3  
 XF=.12  
 YF=.0257  
 ZF=5.73

Figure 18.  
 Elements 201 to 250

Elements 251 to 300, stem between  
C.S.32 and 16

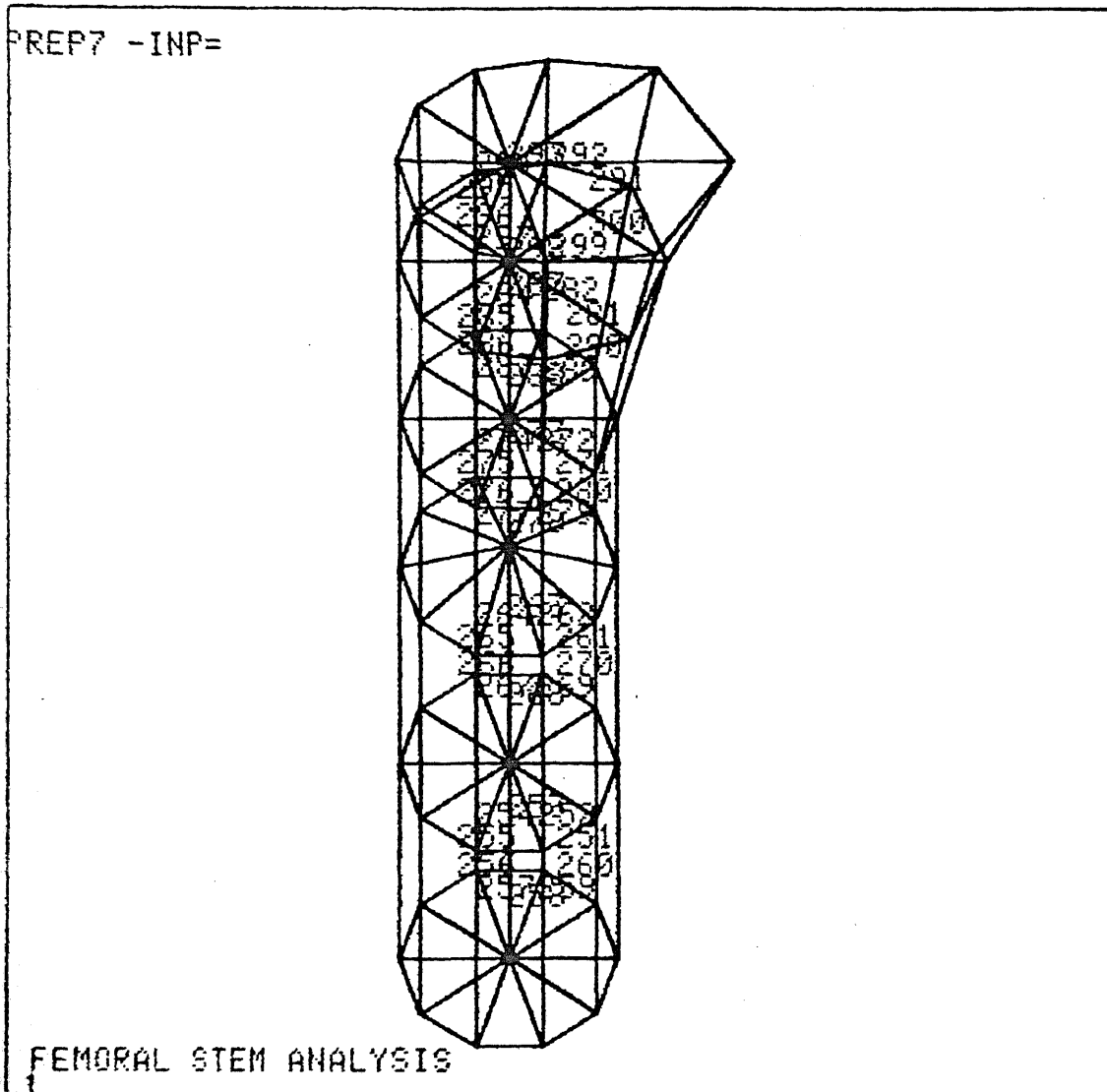
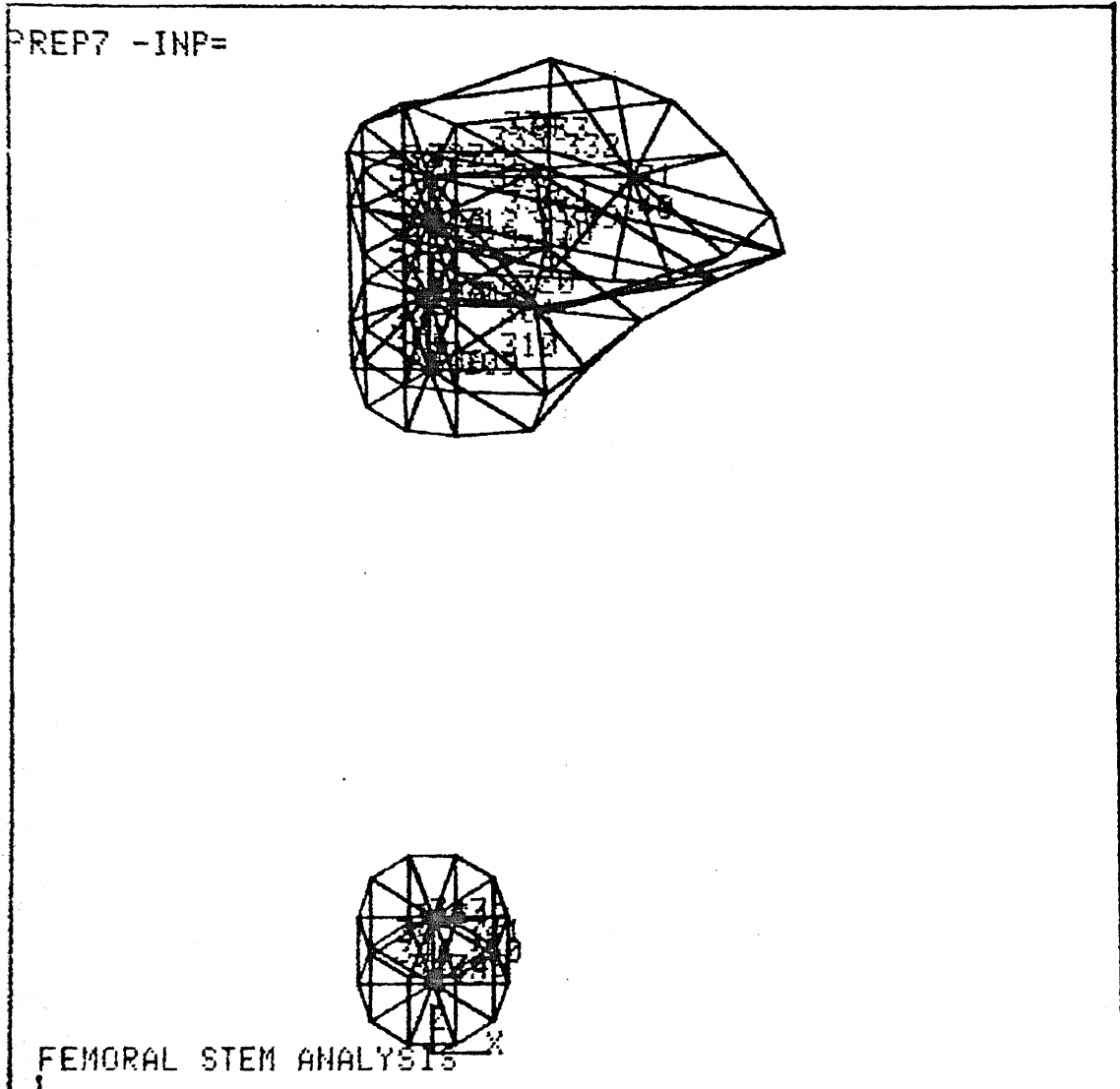

Figure 19.  
Elements 251 to 300

Elements 301 to 340, stem between  
C.S.16 and neck  
of prosthesis  
Elements 341 to 350, stem between  
C.S.32 and stem  
tip



ANSYS  
3/23/84  
10.5824  
PREP7 ELEMENTS  
EMIN=301  
EMAX=350  
ENUM=1  
  
AUTO SCALING  
YU=-1  
ZU=2  
DIST=1.79  
XF=.445  
YF=.0489  
ZF=3.59

Figure 20.  
Elements 301 to 350



Elements 351 to 360, cement between  
C.S.36 and stem  
tip

Elements 361 to 395, remaining cortical bone  
beneath neck to the  
greater trochanter

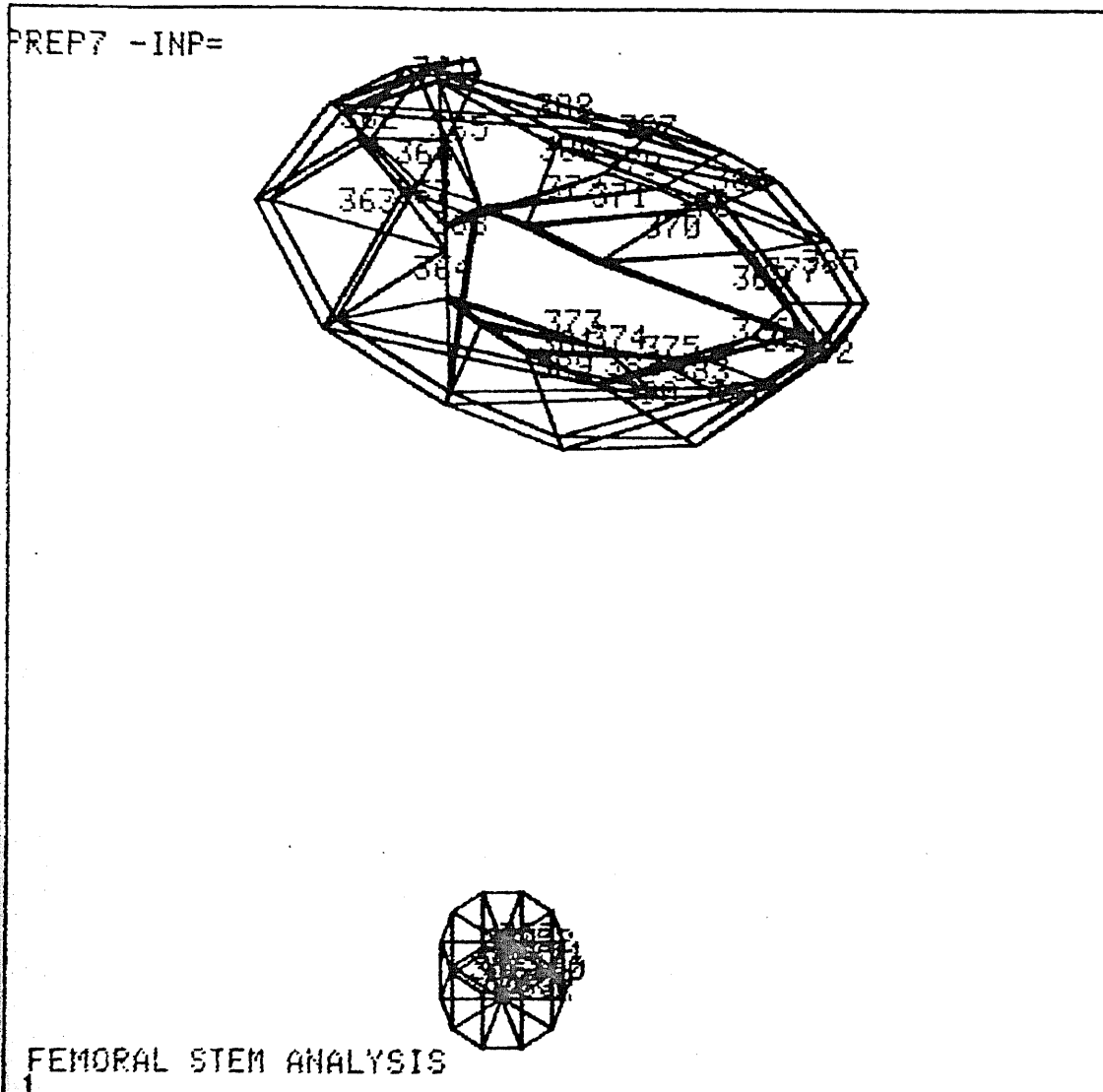

ANSYS  
3/23/84  
10.9106  
PREP7 ELEMENTS  
EMIN=351  
EMAX=395  
ENUM=1

AUTO SCALING  
YU=-1  
ZU=2  
DIST=2.16  
XF=.23  
YF=.0282  
ZF=3.68

Figure 21.  
Elements 351 to 395

A graphic representation of all  
Elements from 1 to 400

PREP7 -INP=

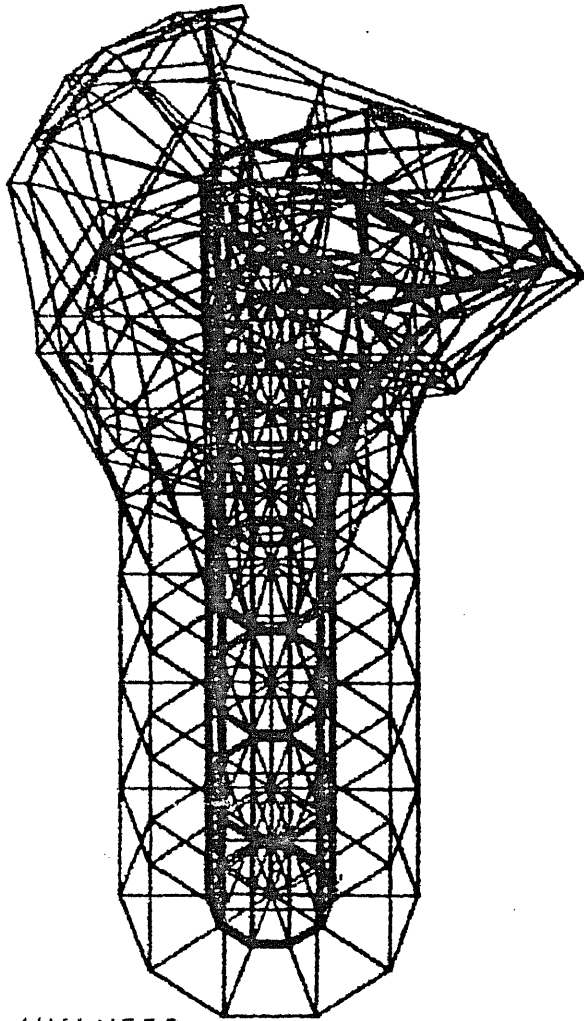

FEMORAL STEM ANALYSIS

ANSYS  
3/23/84  
10.2412  
PREP7 ELEMENTS  
EMAX=400

AUTO SCALING  
YU=-1  
ZU=2  
DIST=2.33  
XF=.12  
YF=-.0753  
ZF=3.74

Figure 22.  
Elements 1 to 400

Elements 403 to 442, ball and neck of  
prosthesis

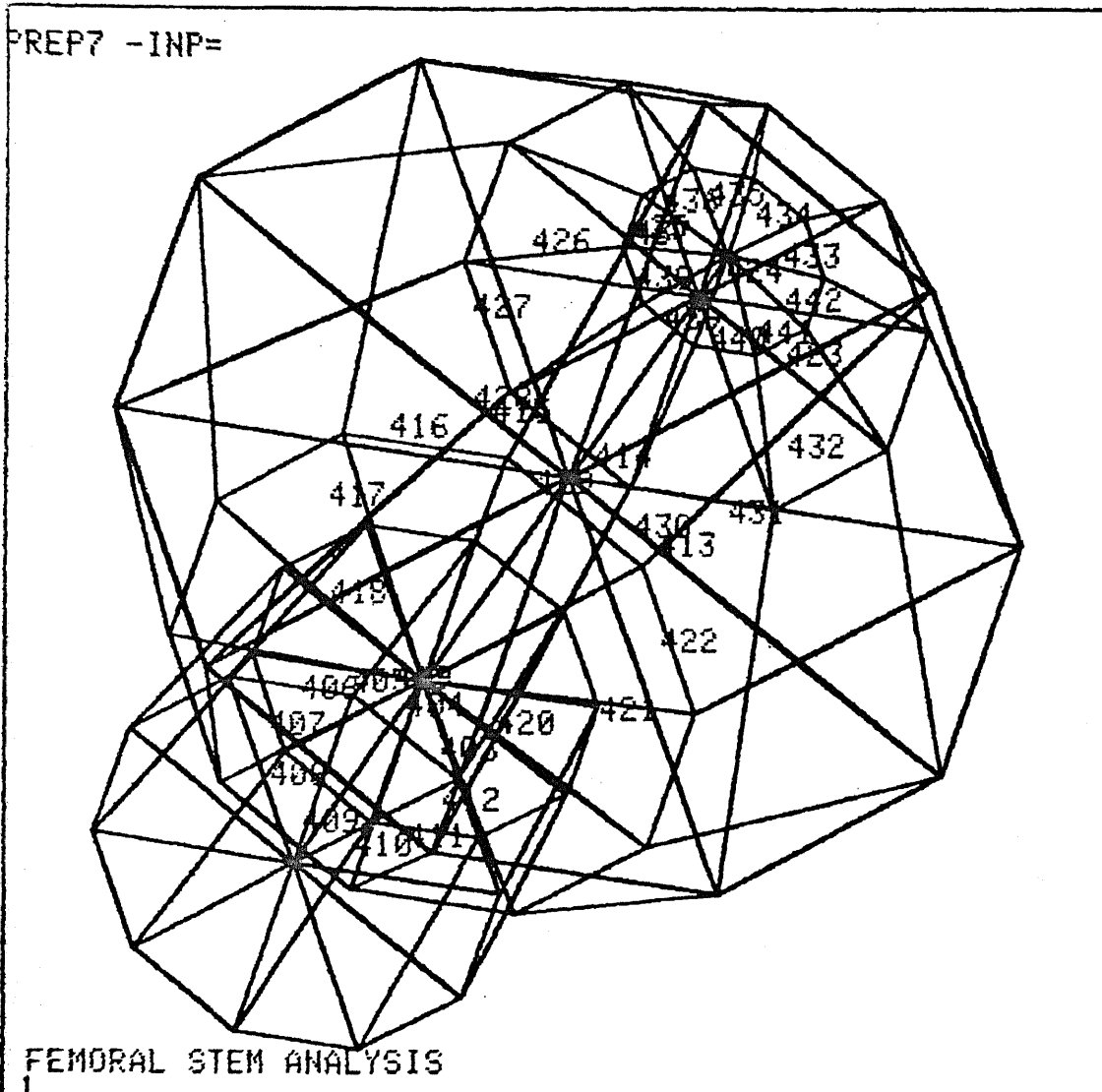

ANSYS  
3/23/84  
12.8225  
PREP7 ELEMENTS  
EMIN=403  
EMAX=450  
ENUM=1

AUTO SCALING  
YU=-1  
ZU=2  
DIST=.716  
XF=1.23  
YF=.0627  
ZF=7.25

Figure 23.  
Elements 403 to 450

The complete model with all elements

PREP7 -INP=

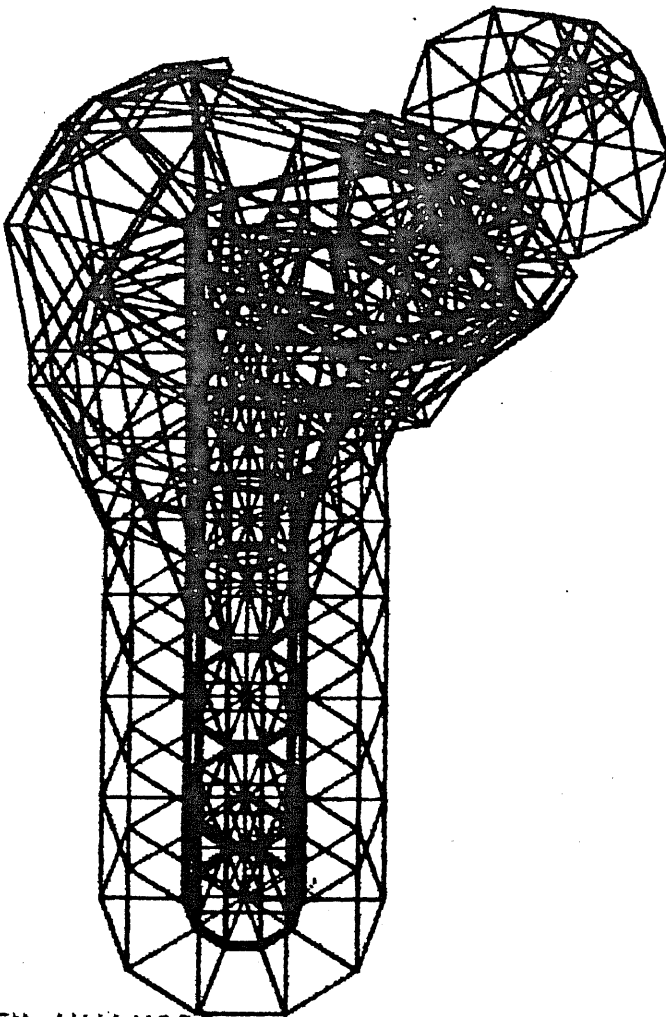

ANSYS  
3/23/84  
12.8823  
PREP7 ELEMENTS  
EMAX=470

AUTO SCALING  
YU=-1  
ZU=2  
DIST=2.45  
XF=.387  
YF=-.0355  
ZF=3.92

FEMDRAL STEM ANALYSIS

Figure 24  
Elements 1 to 442

## VIII DISCUSSION OF COMPUTER EXECUTION

Due to limited storage space available, the model could not be fully executed, demonstrating the fact that a model of such detail requires large amounts of space for execution.

The execution used up the maximum allocated space of 13,000 blocks, where one block equals 512 bytes. Swanson Analysis, creators of ANSYS, commented that the full execution would take, at least, double that amount. It must be stressed that the model did not fail or could not run because of errors.

Proof of no errors can be found in Appendix B where the print out shows that the model went through the check module and responds with "no fatal errors". This does not ascertain accurate correct answers, but it does ascertain a solution can be executed. Numerous efforts were made to try reducing the number of nodes and elements with the risk of destroying the accuracy of the model, but the efforts did not succeed.

Unfortunately, the solution phase, when storage space was exceeded, aborted the execution. The solution phase is also the final phase of using the computer program. Therefore, the solution phase shows the results of all previous work. In this case, all previous work was done, yet the results of the modeling could not be seen. It should be noted that execution was tried interactively and batch.

Since the author is confident of the program and model, the reader who wishes to execute the solution phase should have no problem on a computer system where more space is available.

(To New Jersey Institute of Technology computer users - exceeded space caused by limitations was encountered on VAX System A. There are many users on this system; therefore, more space was impossible to allocate. It should be noted that the average VAX user is only allocated 2,000 blocks. Numerous efforts were attempted using enormous amounts of time to execute the program on VAX System B. This proved to be a failure since VAX System B does not have a disc reader. Links between systems was attempted but inaccurate and inconsistent information and data was transmitted.)

## IX SUMMARY

A complete geometric finite element, three-dimensional model of a femoral stem in a total hip prosthesis has been generated.

The ANSYS Finite Element Program is used in the generation of this system involving cortical and cancellous bone, acrylic bone cement, and either cobalt-chromium or titanium - 6% Al - 4% Va - alloys.

To construct the model, various studies were incorporated. Koch's study (Ref. 11) is used for cortical and cancellous bone geometry. Paul's study (Ref. 12) is used for the joint, muscle, and ligament forces actions. Exact nodal locations, element descriptions, and load inputs are presented if the reader desires to execute the model to produce stress values.

## X REFERENCES

- 1) Crowninshield, Pedersen, and Brano, "A Measurement of Proximal Femur Strain with Total Hip Arthroplasty," Journal of Biomechanical Engineering, August, 1980, pp. 230-233.
- 2) Williams, D.F., "Total Hip Replacement," Implants in Surgery, 1973, pp. 398-416.
- 3) Jacob and Huggler, "An Investigation Into Biomechanical Causes of Prosthesis Stem Loosening Within the Proximal End of the Human Femur," Journal of Biomechanics, Vol. 13, May 1979, pp. 159-173.
- 4) Pellicci, Salvati, Robinson, "Mechanical Failures in Total Hip Replacement Requiring Reoperation," The Journal of Bone and Joint Surgery, Vol. 61-A, No. 1, Jan. 1979, pp. 28-35.
- 5) Collis, Dennis, "Femoral Stem Failure in Total Hip Replacement," The Journal of Bone and Joint Surgery, Vol. 59-A, No. 8, Dec. 1977, pp. 1033-41.
- 6) Sih, and Matic, "Failure Prediction of the Total Hip Prosthesis System," Journal of Biomechanics, Vol. 14, No. 12, 1983, pp. 833-41.
- 7) Andriacchi, Galante, Belytschko, and Hampton, "A Stress Analysis of the Femoral Stem in Total Hip Prosthesis," The Journal of Bone and Joint Surgery, Vol. 58-A, No. 5, July 1976, pp. 618-623.
- 8) Norrie and DeVries, An Introduction to Finite Element Analysis, Academic Press, N.Y., 1978.
- 9) International Conference Proceedings "Review of Existing Finite Element Models," Finite Elements In Biomechanics, University of Arizona, February, 1980.
- 10) International Conference Proceedings, "Finite Element Analysis of Total Hip Prosthesis," Finite Elements In Biomechanics, University of Arizona, February, 1980.
- 11) Koch, John, "The Laws of Bone Architecture," The American Journal of Anatomy, Vol. 21, No. 2, March, 1917, pp. 179-268.
- 12) Paul, John, "Load Actions on the Human Femur," Experimental Mechanics, March, 1971, pp. 121-125.
- 13) Pappas, M., New Jersey Femoral Stem, Endomedics, Inc., Red Bank, N.J.



- 14) Paul, John, "Approaches to Design," Proceedings of the Royal Society of London, 1976, pp. 163-172.
- 15) Williams, D.F., "Selection of Implant Materials," Implants In Surgery, 1979, pp. 299-322.
- 16) Metallurgy of Orthopaedic Implant Materials, Howmedica, Inc., East Rutherford, N.J., 1978.
- 17) Harris, "Corrosion of Stainless Steel Surgical Implants," Journal of Medical Engineering and Technology, May 1979, pp. 117-120
- 18) American Society of Testing and Materials, National Standards, 1981, pp. 286, 596.
- 19) Williams, D.F., "Titanium as a Metal for Implantation," Journal of Medical Engineering and Technology, Sept., 1981, pp. 195, 267-8.
- 20) Pappas, M., from notes on proposed paper, NJIT, Newark, N.J., Nov., 1983.
- 21) "Users Manual," ANSYS Engineering Analysis System, Swanson Analysis System, Inc., Houston, Penn., 1983.
- 22) Wilson, Taylor, et al., "Incompatible Displacement Models," Numerical and Computer Methods in Structural Mechanics, Academic Press, Inc., N.Y., 1973, pp. 43-57.
- 23) "Theoretical Manual," ANSYS Engineering Analysis System, Swanson Analysis System, Inc., Houston, Penn., 1983.

## APPENDIX A

The following figures are the actual, true size, cross-sectional views of the human femur used. Note that the cross-sections are perverted to the view of the cross-sections in Figure 3.

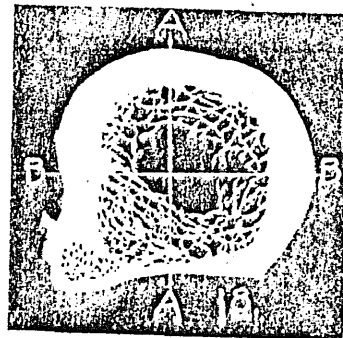
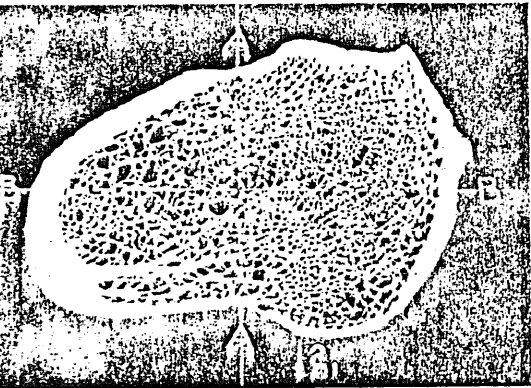
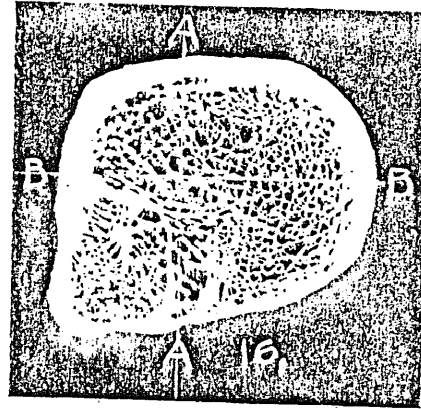
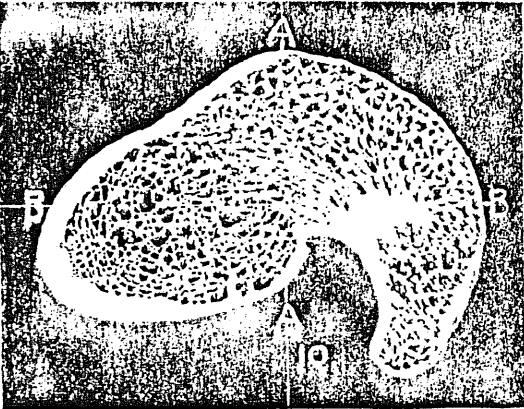
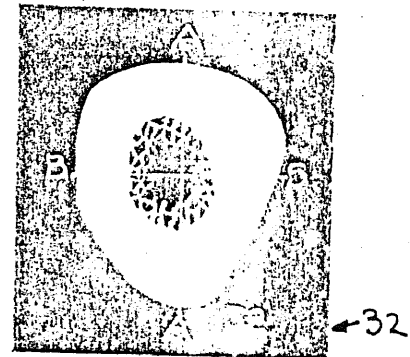
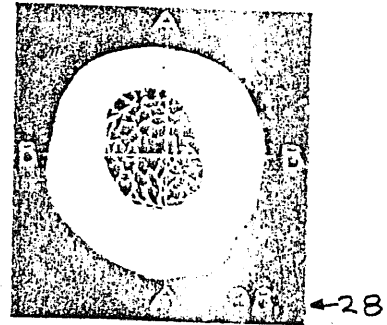
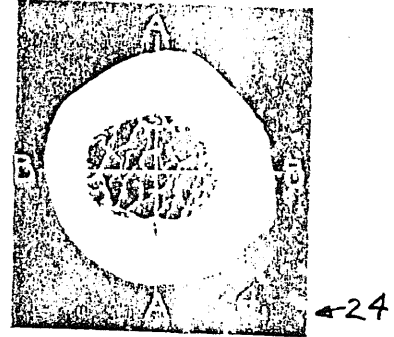
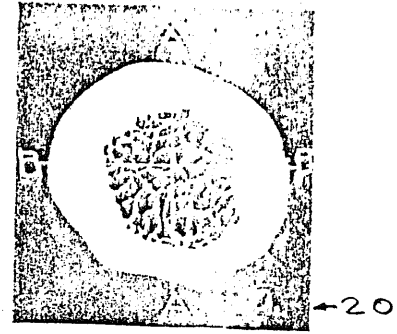
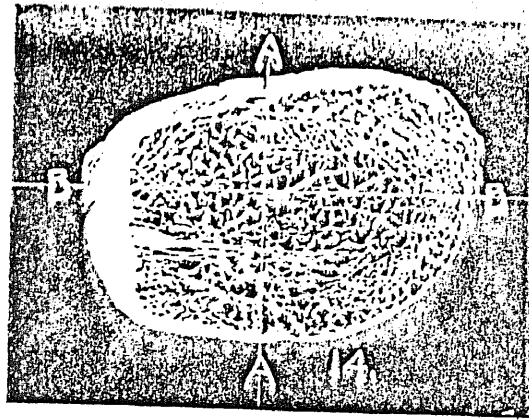
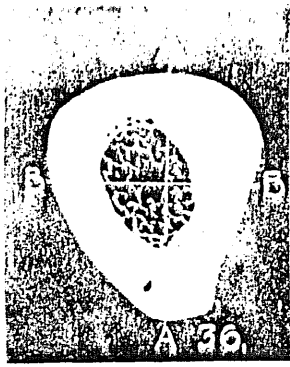

Figures 25 to 34  
Bone cross-sections (Reproduced from Ref. 11)

## APPENDIX B

The following pages represent computer printouts. The first figure proves the execution of the check module showing that no fatal errors were found. Following that the message of full disc space is illustrated also showing the typical ANSYS warning message displayed at time of execution.

REWRITE

\*\*\* NOTE \*\*\* KRF KEY NOT SET - NO NODAL OR REACTION FORCES  
WILL BE AVAILABLE FOR POSTPROCESSING

DATA CHECKED - NO ERRORS FOUND

ANALYSIS DATA WRITTEN ON FILE27 ( 1446 LINES)

\*\*\* PREP7 GLOBAL STATUS \*\*\*

TITLE= 'FEMORAL STEM ANALYSIS'

ANALYSIS TYPE= 0  
NUMBER OF ELEMENT TYPES= 1  
NUMBER OF ELEMENTS= 442  
MAXIMUM LINEAR PROPERTY NUMBER= 5  
ACTIVE COORDINATE SYSTEM= 0 (CARTESIAN)  
NUMBER OF IMPOSED DISPLACEMENTS= 90  
NUMBER OF NODAL FORCES= 7

ENTER -FINISH TO LEAVE PREP7

IF YOU WANT TO EXECUTE THIS ANALYSIS ENTER  
/INPUT,27 (FOR CHECK)  
/EXEC \$/INPUT,27 (FOR SOLUTION)  
PREP7 -INF=

FEMORAL STEM ANALYSIS  
\*\*UNIVERSITY VERSION FOR EDUCATIONAL PURPOSES ONLY\*\*

LOAD STEP NUMBER= 1

\*\*\* LOAD OPTIONS SUMMARY \*\*\*

TIME = 0.00000E+00 (TIME AT END OF LOAD STEP)  
NITITER = 1 (NUMBER OF ITERATIONS)  
TUNIF = 0.0000 (UNIFORM TEMPERATURE) (TREF = 0.0000)  
KTEMP = 0 (USE TUNIF FOR ALL NODAL TEMPERATURES)

NPRINT = 1 (OVERALL PRINT FREQUENCY)  
NPOST = 1 (OVERALL POST FREQUENCY)

DISPLACEMENT PRINT FREQUENCIES

FREQ	NSTART	NSTOP	NINC
1	1	99900	1

ELEMENT PRINT AND POST FREQUENCIES

TYPE	STIFF NO.	STRESS PRINT	FORCE PRINT	STRESS POST	STRESS LEVEL	FORCE POST
1	45	1	1	1	3	1

\*\*\*\*\* LOAD SUMMARY - 1 DISPLACEMENTS 5 FORCES 0 PRESSURES

INTEGER STORAGE REQUIREMENTS FOR LOAD DATA INPUT CP= 1  
MEMORY I= 174 MEMORY II= 0 TOTAL= 174 MEMORY AVAILABLE=

\*\*\*\*\* INPUT-OUTPUT ERROR KFUN= 2 UNIT= 2

\*\*\*DISK WRITE ERROR (PROBABLE FULL DISK)-RUN ABORTED

\*\*\*\*\* NOTICE \*\*\*\*\* THIS IS THE ANSYS GENERAL PURPOSE  
FINITE ELEMENT COMPUTER PROGRAM. NEITHER SWANSON ANALYSIS  
SYSTEMS, INC. NOR THE CORPORATION SUPPLYING THE COMPUTER  
FACILITIES FOR THIS ANALYSIS ASSUME ANY RESPONSIBILITY FOR  
THE VALIDITY, ACCURACY, OR APPLICABILITY OF ANY RESULTS  
OBTAINED FROM THE ANSYS SYSTEM. THE USER MUST VERIFY HIS  
OWN RESULTS.

USE /INTER,NO TO SUPPRESS THIS NOTICE  
BEGIN =

## APPENDIX C

The following pages represent the complete geometric model. The Table of Nodes show the X, Y, and Z components of all the nodes. The next table is of the elements. Shown is the element number, the material reference number for each element, and the eight nodes that construct the element.

TABLE 2  
LIST OF NODES

<u>NODE</u>	<u>X</u>	<u>Y</u>	<u>Z</u>
1	0. 23750	0. 00000E+00	0. 00000E+00
2	0. 19214	0. 13960	0. 00000E+00
3	0. 73392E-01	0. 22588	0. 00000E+00
4	-0. 73392E-01	0. 22588	0. 00000E+00
5	-0. 19214	0. 13960	0. 00000E+00
6	-0. 23750	0. 41452E-05	0. 00000E+00
7	-0. 19214	-0. 13960	0. 00000E+00
8	-0. 73392E-01	-0. 22588	0. 00000E+00
9	0. 73392E-01	-0. 22588	0. 00000E+00
10	0. 19214	-0. 13960	0. 00000E+00
11	0. 25720	0. 00000E+00	0. 00000E+00
12	0. 20808	0. 15118	0. 00000E+00
13	0. 79479E-01	0. 24461	0. 00000E+00
14	-0. 79479E-01	0. 24461	0. 00000E+00
15	-0. 20808	0. 15118	0. 00000E+00
16	-0. 25720	0. 44890E-05	0. 00000E+00
17	-0. 20808	-0. 15118	0. 00000E+00
18	-0. 79479E-01	-0. 24461	0. 00000E+00
19	0. 79479E-01	-0. 24461	0. 00000E+00
20	0. 20808	-0. 15118	0. 00000E+00
21	0. 60000	0. 00000E+00	0. 00000E+00
22	0. 48541	0. 35267	0. 00000E+00
23	0. 18541	0. 57063	0. 00000E+00
24	-0. 18541	0. 57063	0. 00000E+00



TABLE 2 (Con't)

LIST OF NODES

<u>NODE</u>	<u>X</u>	<u>Y</u>	<u>Z</u>
25	-0. 48541	0. 35267	0. 00000E+00
26	-0. 60000	0. 10472E-04	0. 00000E+00
27	-0. 48541	-0. 35267	0. 00000E+00
28	-0. 18541	-0. 57063	0. 00000E+00
29	0. 18541	-0. 57063	0. 00000E+00
30	0. 48541	-0. 35267	0. 00000E+00
31	0. 23750	0. 00000E+00	1. 0000
32	0. 19214	0. 13960	1. 0000
33	0. 73392E-01	0. 22588	1. 0000
34	-0. 73392E-01	0. 22588	1. 0000
35	-0. 19214	0. 13960	1. 0000
36	-0. 23750	0. 41452E-05	1. 0000
37	-0. 19214	-0. 13960	1. 0000
38	-0. 73392E-01	-0. 22588	1. 0000
39	0. 73392E-01	-0. 22588	1. 0000
40	0. 19214	-0. 13960	1. 0000
41	0. 25720	0. 00000E+00	1. 0000
42	0. 20808	0. 15118	1. 0000
43	0. 79479E-01	0. 24461	1. 0000
44	-0. 79479E-01	0. 24461	1. 0000
45	-0. 20808	0. 15118	1. 0000
46	-0. 25720	0. 44890E-05	1. 0000
47	-0. 20808	-0. 15118	1. 0000
48	-0. 79479E-01	-0. 24461	1. 0000

TABLE 2 (Con't)

LIST OF NODES

<u>NODE</u>	<u>X</u>	<u>Y</u>	<u>Z</u>
49	0. 79479E-01	-0. 24461	1. 0000
50	0. 20808	-0. 15118	1. 0000
51	0. 60000	0. 00000E+00	1. 0000
52	0. 48541	0. 35267	1. 0000
53	0. 18541	0. 57063	1. 0000
54	-0. 18541	0. 57063	1. 0000
55	-0. 48541	0. 35267	1. 0000
56	-0. 60000	0. 10472E-04	1. 0000
57	-0. 48541	-0. 35267	1. 0000
58	-0. 18541	-0. 57063	1. 0000
59	0. 18541	-0. 57063	1. 0000
60	0. 48541	-0. 35267	1. 0000
61	0. 23750	0. 00000E+00	2. 0000
62	0. 19214	0. 13960	2. 0000
63	0. 73392E-01	0. 22588	2. 0000
64	-0. 73392E-01	0. 22588	2. 0000
65	-0. 19214	0. 13960	2. 0000
66	-0. 23750	0. 41452E-05	2. 0000
67	-0. 19214	-0. 13960	2. 0000
68	-0. 73392E-01	-0. 22588	2. 0000
69	0. 73392E-01	-0. 22588	2. 0000
70	0. 19214	-0. 13960	2. 0000
71	0. 25720	0. 00000E+00	2. 0000
72	0. 20808	0. 15118	2. 0000

TABLE 2 (Con't)

LIST OF NODES

<u>NODE</u>	<u>X</u>	<u>Y</u>	<u>Z</u>
73	0. 79479E-01	0. 24461	2. 0000
74	-0. 79479E-01	0. 24461	2. 0000
75	-0. 20808	0. 15118	2. 0000
76	-0. 25720	0. 44890E-05	2. 0000
77	-0. 20808	-0. 15118	2. 0000
78	-0. 79479E-01	-0. 24461	2. 0000
79	0. 79479E-01	-0. 24461	2. 0000
80	0. 20808	-0. 15118	2. 0000
81	0. 60000	0. 00000E+00	2. 0000
82	0. 48541	0. 35267	2. 0000
83	0. 18541	0. 57063	2. 0000
84	-0. 18541	0. 57063	2. 0000
85	-0. 48541	0. 35267	2. 0000
86	-0. 60000	0. 10472E-04	2. 0000
87	-0. 48541	-0. 35267	2. 0000
88	-0. 18541	-0. 57063	2. 0000
89	0. 18541	-0. 57063	2. 0000
90	0. 48541	-0. 35267	2. 0000
91	0. 23750	0. 00000E+00	3. 0000
92	0. 19214	0. 13960	3. 0000
93	0. 73392E-01	0. 22588	3. 0000
94	-0. 73392E-01	0. 22588	3. 0000
95	-0. 19214	0. 13960	3. 0000
96	-0. 23750	0. 41452E-05	3. 0000

TABLE 2 (Con't)

LIST OF NODES

<u>NODE</u>	<u>X</u>	<u>Y</u>	<u>Z</u>
97	-0. 19214	-0. 13960	3. 0000
98	-0. 73392E-01	-0. 22588	3. 0000
99	0. 73392E-01	-0. 22588	3. 0000
100	0. 19214	-0. 13960	3. 0000
101	0. 25720	0. 00000E+00	3. 0000
102	0. 20808	0. 15118	3. 0000
103	0. 79479E-01	0. 24461	3. 0000
104	-0. 79479E-01	0. 24461	3. 0000
105	-0. 20808	0. 15118	3. 0000
106	-0. 25720	0. 44890E-05	3. 0000
107	-0. 20808	-0. 15118	3. 0000
108	-0. 79479E-01	-0. 24461	3. 0000
109	0. 79479E-01	-0. 24461	3. 0000
110	0. 20808	-0. 15118	3. 0000
111	0. 60000	0. 00000E+00	3. 0000
112	0. 48541	0. 35267	3. 0000
113	0. 18541	0. 57063	3. 0000
114	-0. 18541	0. 57063	3. 0000
115	-0. 48541	0. 35267	3. 0000
116	-0. 60000	0. 10472E-04	3. 0000
117	-0. 48541	-0. 35267	3. 0000
118	-0. 18541	-0. 57063	3. 0000
119	0. 18541	-0. 57063	3. 0000
120	0. 48541	-0. 35267	3. 0000

TABLE 2 (Con't)

LIST OF NODES

<u>NODE</u>	<u>X</u>	<u>Y</u>	<u>Z</u>
121	0. 27690	0. 00000E+00	3. 0000
122	0. 22402	0. 16276	3. 0000
123	0. 85567E-01	0. 26335	3. 0000
124	-0. 85567E-01	0. 26335	3. 0000
125	-0. 22402	0. 16276	3. 0000
126	-0. 27690	0. 48328E-05	3. 0000
127	-0. 22402	-0. 16276	3. 0000
128	-0. 85567E-01	-0. 26335	3. 0000
129	0. 85567E-01	-0. 26335	3. 0000
130	0. 22402	-0. 16276	3. 0000
131	0. 23750	0. 00000E+00	3. 7500
132	0. 19214	0. 13960	3. 7500
133	0. 73392E-01	0. 22588	3. 7500
134	-0. 73392E-01	0. 22588	3. 7500
135	-0. 19214	0. 13960	3. 7500
136	-0. 23750	0. 41452E-05	3. 7500
137	-0. 19214	-0. 13960	3. 7500
138	-0. 73392E-01	-0. 22588	3. 7500
139	0. 73392E-01	-0. 22588	3. 7500
140	0. 19214	-0. 13960	3. 7500
141	0. 25720	0. 00000E+00	3. 7500
142	0. 20808	0. 15118	3. 7500
143	0. 79479E-01	0. 24461	3. 7500
144	-0. 79479E-01	0. 24461	3. 7500

TABLE 2 (Con't)

LIST OF NODES

<u>NODE</u>	<u>X</u>	<u>Y</u>	<u>Z</u>
145	-0. 20808	0. 15118	3. 7500
146	-0. 25720	0. 44890E-05	3. 7500
147	-0. 20808	-0. 15118	3. 7500
148	-0. 79479E-01	-0. 24461	3. 7500
149	0. 79479E-01	-0. 24461	3. 7500
150	0. 20808	-0. 15118	3. 7500
151	0. 60000	0. 00000E+00	3. 7500
152	0. 48541	0. 35267	3. 7500
153	0. 18541	0. 57063	3. 7500
154	-0. 18541	0. 57063	3. 7500
155	-0. 48541	0. 35267	3. 7500
156	-0. 60000	0. 10472E-04	3. 7500
157	-0. 48541	-0. 35267	3. 7500
158	-0. 18541	-0. 57063	3. 7500
159	0. 18541	-0. 57063	3. 7500
160	0. 48541	-0. 35267	3. 7500
161	0. 40000	0. 00000E+00	3. 7500
162	0. 32361	0. 23511	3. 7500
163	0. 12361	0. 38042	3. 7500
164	-0. 12361	0. 38042	3. 7500
165	-0. 32361	0. 23511	3. 7500
166	-0. 40000	0. 69813E-05	3. 7500
167	-0. 32361	-0. 23511	3. 7500
168	-0. 12361	-0. 38042	3. 7500

TABLE 2 (Con't)

LIST OF NODES

<u>NODE</u>	<u>X</u>	<u>Y</u>	<u>Z</u>
169	0. 12361	-0. 38042	3. 7500
170	0. 32361	-0. 23511	3. 7500
171	0. 35000	0. 00000E+00	4. 5500
172	0. 26698	0. 19397	4. 5500
173	0. 80344E-01	0. 24727	4. 5500
174	-0. 74164E-01	0. 22825	4. 5500
175	-0. 19416	0. 14107	4. 5500
176	-0. 24000	0. 41888E-05	4. 5500
177	-0. 19416	-0. 14107	4. 5500
178	-0. 74164E-01	-0. 22825	4. 5500
179	0. 80344E-01	-0. 24727	4. 5500
180	0. 26698	-0. 19397	4. 5500
181	0. 36970	0. 00000E+00	4. 5500
182	0. 28291	0. 20555	4. 5500
183	0. 86432E-01	0. 26601	4. 5500
184	-0. 80252E-01	0. 24699	4. 5500
185	-0. 21010	0. 15265	4. 5500
186	-0. 25970	0. 45326E-05	4. 5500
187	-0. 21010	-0. 15265	4. 5500
188	-0. 80252E-01	-0. 24699	4. 5500
189	0. 86432E-01	-0. 26601	4. 5500
190	0. 28291	-0. 20555	4. 5500
191	0. 58000	0. 00000E+00	4. 5500
192	0. 56631	0. 41145	4. 5500

TABLE 2 (Con't)

LIST OF NODES

<u>NODE</u>	<u>X</u>	<u>Y</u>	<u>Z</u>
193	0. 20086	0. 61819	4. 5500
194	-0. 19468	0. 59917	4. 5500
195	-0. 56631	0. 41145	4. 5500
196	-0. 75000	0. 13090E-04	4. 5500
197	-0. 60676	-0. 44084	4. 5500
198	-0. 19777	-0. 60868	4. 5500
199	0. 18541	-0. 57063	4. 5500
200	0. 48541	-0. 35267	4. 5500
201	0. 38000	0. 00000E+00	4. 5500
202	0. 40451	0. 29389	4. 5500
203	0. 13906	0. 42798	4. 5500
204	-0. 13288	0. 40895	4. 5500
205	-0. 40451	0. 29389	4. 5500
206	-0. 55000	0. 95993E-05	4. 5500
207	-0. 44496	-0. 32328	4. 5500
208	-0. 13597	-0. 41846	4. 5500
209	0. 12361	-0. 38042	4. 5500
210	0. 32361	-0. 23511	4. 5500
211	0. 50000	0. 00000E+00	5. 0600
212	0. 32361	0. 23511	5. 0600
213	0. 83435E-01	0. 25679	5. 0600
214	-0. 75709E-01	0. 23301	5. 0600
215	-0. 19821	0. 14401	5. 0600
216	-0. 24500	0. 42761E-05	5. 0600



TABLE 2 (Con't)

LIST OF NODES

<u>NODE</u>	<u>X</u>	<u>Y</u>	<u>Z</u>
217	-0. 19821	-0. 14401	5. 0600
218	-0. 75709E-01	-0. 23301	5. 0600
219	0. 83435E-01	-0. 25679	5. 0600
220	0. 32361	-0. 23511	5. 0600
221	0. 51970	0. 00000E+00	5. 0600
222	0. 33954	0. 24669	5. 0600
223	0. 89522E-01	0. 27552	5. 0600
224	-0. 81797E-01	0. 25174	5. 0600
225	-0. 21415	0. 15559	5. 0600
226	-0. 26470	0. 46199E-05	5. 0600
227	-0. 21415	-0. 15559	5. 0600
228	-0. 81797E-01	-0. 25174	5. 0600
229	0. 89522E-01	-0. 27552	5. 0600
230	0. 33954	-0. 24669	5. 0600
231	0. 70000	0. 00000E+00	5. 0600
232	0. 66339	0. 48198	5. 0600
233	0. 24721	0. 76085	5. 0600
234	-0. 22249	0. 68476	5. 0600
235	-0. 66339	0. 48198	5. 0600
236	-0. 94000	0. 16406E-04	5. 0600
237	-0. 68766	-0. 49962	5. 0600
238	-0. 20086	-0. 61819	5. 0600
239	0. 18541	-0. 57063	5. 0600
240	0. 55013	-0. 39969	5. 0600

TABLE 2 (Con't)

LIST OF NODES

<u>NODE</u>	<u>X</u>	<u>Y</u>	<u>Z</u>
241	0. 60000	0. 00000E+00	5. 0600
242	0. 58249	0. 42321	5. 0600
243	0. 21631	0. 66574	5. 0600
244	-0. 19159	0. 58966	5. 0600
245	-0. 58249	0. 42321	5. 0600
246	-0. 84000	0. 14661E-04	5. 0600
247	-0. 60676	-0. 44084	5. 0600
248	-0. 16996	-0. 52308	5. 0600
249	0. 15451	-0. 47553	5. 0600
250	0. 46923	-0. 34092	5. 0600
251	0. 68000	0. 00000E+00	5. 4000
252	0. 37215	0. 27038	5. 4000
253	0. 84980E-01	0. 26154	5. 4000
254	-0. 77254E-01	0. 23776	5. 4000
255	-0. 20225	0. 14695	5. 4000
256	-0. 25000	0. 43633E-05	5. 4000
257	-0. 20225	-0. 14695	5. 4000
258	-0. 77254E-01	-0. 23776	5. 4000
259	0. 84980E-01	-0. 26154	5. 4000
260	0. 37215	-0. 27038	5. 4000
261	0. 69970	0. 00000E+00	5. 4000
262	0. 38809	0. 28196	5. 4000
263	0. 91067E-01	0. 28028	5. 4000
264	-0. 83342E-01	0. 25650	5. 4000

TABLE 2 (Con't)

LIST OF NODES

<u>NODE</u>	<u>X</u>	<u>Y</u>	<u>Z</u>
265	-0. 21819	0. 15853	5. 4000
266	-0. 26970	0. 47072E-05	5. 4000
267	-0. 21819	-0. 15853	5. 4000
268	-0. 83342E-01	-0. 25650	5. 4000
269	0. 91067E-01	-0. 28028	5. 4000
270	0. 38809	-0. 28196	5. 4000
271	0. 80000	0. 00000E+00	5. 4000
272	0. 64721	0. 47023	5. 4000
273	0. 24721	0. 76085	5. 4000
274	-0. 22249	0. 68476	5. 4000
275	-0. 67957	0. 49374	5. 4000
276	-0. 95000	0. 16581E-04	5. 4000
277	-0. 68766	-0. 49962	5. 4000
278	-0. 20086	-0. 61819	5. 4000
279	0. 18541	-0. 57063	5. 4000
280	0. 53395	-0. 38794	5. 4000
281	0. 72000	0. 00000E+00	5. 4000
282	0. 57440	0. 41733	5. 4000
283	0. 21940	0. 67525	5. 4000
284	-0. 19468	0. 59917	5. 4000
285	-0. 60676	0. 44084	5. 4000
286	-0. 86000	0. 15010E-04	5. 4000
287	-0. 61485	-0. 44672	5. 4000
288	-0. 17305	-0. 53259	5. 4000

TABLE 2 (Con't)

LIST OF NODES

<u>NODE</u>	<u>X</u>	<u>Y</u>	<u>Z</u>
289	0. 15760	-0. 48504	5. 4000
290	0. 46114	-0. 33504	5. 4000
291	0. 93000	0. 00000E+00	5. 7000
292	0. 33979	0. 24687	6. 0000
293	0. 86525E-01	0. 26630	6. 0500
294	-0. 78799E-01	0. 24252	6. 1600
295	-0. 20630	0. 14989	6. 2000
296	-0. 25500	0. 44506E-05	6. 2500
297	-0. 20630	-0. 14989	6. 2000
298	-0. 78799E-01	-0. 24252	6. 1600
299	0. 86525E-01	-0. 26630	6. 0500
300	0. 33979	-0. 24687	6. 0000
301	0. 94970	0. 00000E+00	5. 7000
302	0. 35572	0. 25845	6. 0000
303	0. 92612E-01	0. 28503	6. 0500
304	-0. 84887E-01	0. 26126	6. 1600
305	-0. 22224	0. 16146	6. 2000
306	-0. 27470	0. 47944E-05	6. 2500
307	-0. 22224	-0. 16146	6. 2000
308	-0. 84887E-01	-0. 26126	6. 1600
309	0. 92612E-01	-0. 28503	6. 0500
310	0. 35572	-0. 25845	6. 0000
311	1. 1500	0. 00000E+00	5. 9000
312	0. 88992	0. 64656	5. 8200

TABLE 2 (Con't)

LIST OF NODES

<u>NODE</u>	<u>X</u>	<u>Y</u>	<u>Z</u>
313	0. 20395	0. 62770	6. 3000
314	-0. 24721	0. 76085	6. 2600
315	-0. 80902	0. 58779	6. 4800
316	-1. 0600	0. 18500E-04	6. 6500
317	-0. 74430	-0. 54076	6. 4800
318	-0. 23176	-0. 71329	6. 2600
319	0. 21631	-0. 66574	6. 3000
320	0. 76857	-0. 55840	5. 8200
321	1. 0300	0. 00000E+00	5. 6400
322	0. 82520	0. 59954	5. 8200
323	0. 17923	0. 55161	6. 3000
324	-0. 22249	0. 68476	6. 2600
325	-0. 74430	0. 54076	6. 4800
326	-0. 98000	0. 17104E-04	6. 6500
327	-0. 67957	-0. 49374	6. 4800
328	-0. 20704	-0. 63721	6. 2600
329	0. 19159	-0. 58966	6. 3000
330	0. 70384	-0. 51137	5. 8200
331	1. 1500	0. 00000E+00	5. 9000
332	0. 36406	0. 26450	6. 0000
333	0. 88070E-01	0. 27105	6. 3000
334	-0. 80344E-01	0. 24727	6. 5000
335	-0. 21034	0. 15282	6. 5400
336	-0. 26000	0. 45379E-05	6. 6400

TABLE 2 (Con't)

LIST OF NODES

<u>NODE</u>	<u>X</u>	<u>Y</u>	<u>Z</u>
337	-0. 21034	-0. 15282	6. 5400
338	-0. 80344E-01	-0. 24727	6. 5000
339	0. 88070E-01	-0. 27105	6. 3000
340	0. 36406	-0. 26450	6. 0000
341	1. 1697	0. 00000E+00	5. 9000
342	0. 38000	0. 27608	6. 0000
343	0. 94157E-01	0. 28979	6. 3000
344	-0. 86432E-01	0. 26601	6. 5000
345	-0. 22628	0. 16440	6. 5400
346	-0. 27970	0. 48817E-05	6. 6400
347	-0. 22628	-0. 16440	6. 5400
348	-0. 86432E-01	-0. 26601	6. 5000
349	0. 94157E-01	-0. 28979	6. 3000
350	0. 38000	-0. 27608	6. 0000
351	1. 3000	0. 00000E+00	5. 7800
352	0. 80902	0. 58779	6. 0000
353	0. 22249	0. 68476	6. 3000
354	-0. 26266	0. 80840	6. 6200
355	-0. 66339	0. 48198	6. 9500
356	-0. 96000	0. 16755E-04	7. 0600
357	-0. 68766	-0. 49962	6. 9500
358	-0. 21940	-0. 67525	6. 6200
359	0. 23176	-0. 71329	6. 3000
360	0. 75239	-0. 54664	6. 0000

TABLE 2 (Con't)

LIST OF NODES

<u>NODE</u>	<u>X</u>	<u>Y</u>	<u>Z</u>
361	1. 2400	0. 00000E+00	5. 7800
362	0. 76048	0. 55252	6. 0000
363	0. 20395	0. 62770	6. 3000
364	-0. 24412	0. 75133	6. 6200
365	-0. 61485	0. 44672	6. 9500
366	-0. 90000	0. 15708E-04	7. 0600
367	-0. 63912	-0. 46435	6. 9500
368	-0. 20086	-0. 61819	6. 6200
369	0. 21322	-0. 65623	6. 3000
370	0. 70384	-0. 51137	6. 0000
371	1. 1100	0. 00000E+00	6. 1800
372	0. 96199	0. 18699	6. 2500
373	0. 78243	0. 33212	6. 3500
374	0. 59363	0. 37094	6. 4500
375	0. 38891	0. 38891	6. 5500
376	0. 38000	0. 00000E+00	6. 6500
377	0. 38891	-0. 38891	6. 5500
378	0. 58707	-0. 38125	6. 4500
379	0. 78243	-0. 33212	6. 3500
380	0. 96199	-0. 18699	6. 2500
381	1. 1297	0. 00000E+00	6. 1800
382	0. 98133	0. 19075	6. 2500
383	0. 80056	0. 33982	6. 3500
384	0. 61034	0. 38138	6. 4500

TABLE 2 (Con't)

LIST OF NODES

<u>NODE</u>	<u>X</u>	<u>Y</u>	<u>Z</u>
385	0. 40284	0. 40284	6. 5500
386	0. 37800	0. 00000E+00	6. 5500
387	0. 40284	-0. 40284	6. 5500
388	0. 60359	-0. 39198	6. 4500
389	0. 80056	-0. 33982	6. 3500
390	0. 98133	-0. 19075	6. 2500
400	0. 00000E+00	0. 00000E+00	1. 0000
401	0. 00000E+00	0. 00000E+00	1. 0000
402	0. 00000E+00	0. 00000E+00	1. 0000
403	0. 00000E+00	0. 00000E+00	1. 0000
404	0. 00000E+00	0. 00000E+00	1. 0000
405	0. 00000E+00	0. 00000E+00	1. 0000
406	0. 00000E+00	0. 00000E+00	1. 0000
407	0. 00000E+00	0. 00000E+00	1. 0000
408	0. 00000E+00	0. 00000E+00	1. 0000
409	0. 00000E+00	0. 00000E+00	1. 0000
430	0. 00000E+00	0. 00000E+00	2. 0000
431	0. 00000E+00	0. 00000E+00	2. 0000
432	0. 00000E+00	0. 00000E+00	2. 0000
433	0. 00000E+00	0. 00000E+00	2. 0000
434	0. 00000E+00	0. 00000E+00	2. 0000
435	0. 00000E+00	0. 00000E+00	2. 0000
436	0. 00000E+00	0. 00000E+00	2. 0000
437	0. 00000E+00	0. 00000E+00	2. 0000



TABLE 2 (Con't)

LIST OF NODES

<u>NODE</u>	<u>X</u>	<u>Y</u>	<u>Z</u>
438	0. 00000E+00	0. 00000E+00	2. 0000
439	0. 00000E+00	0. 00000E+00	2. 0000
460	0. 00000E+00	0. 00000E+00	3. 1000
461	0. 00000E+00	0. 00000E+00	3. 1000
462	0. 00000E+00	0. 00000E+00	3. 1000
463	0. 00000E+00	0. 00000E+00	3. 1000
464	0. 00000E+00	0. 00000E+00	3. 1000
465	0. 00000E+00	0. 00000E+00	3. 1000
466	0. 00000E+00	0. 00000E+00	3. 1000
467	0. 00000E+00	0. 00000E+00	3. 1000
468	0. 00000E+00	0. 00000E+00	3. 1000
469	0. 00000E+00	0. 00000E+00	3. 1000
500	0. 00000E+00	0. 00000E+00	3. 7500
501	0. 00000E+00	0. 00000E+00	3. 7500
502	0. 00000E+00	0. 00000E+00	3. 7500
503	0. 00000E+00	0. 00000E+00	3. 7500
504	0. 00000E+00	0. 00000E+00	3. 7500
505	0. 00000E+00	0. 00000E+00	3. 7500
506	0. 00000E+00	0. 00000E+00	3. 7500
507	0. 00000E+00	0. 00000E+00	3. 7500
508	0. 00000E+00	0. 00000E+00	3. 7500
509	0. 00000E+00	0. 00000E+00	3. 7500
540	0. 00000E+00	0. 00000E+00	4. 5500
541	0. 00000E+00	0. 00000E+00	4. 5500

TABLE 2 (Con't)

LIST OF NODES

<u>NODE</u>	<u>X</u>	<u>Y</u>	<u>Z</u>
542	0. 00000E+00	0. 00000E+00	4. 5500
543	0. 00000E+00	0. 00000E+00	4. 5500
544	0. 00000E+00	0. 00000E+00	4. 5500
545	0. 00000E+00	0. 00000E+00	4. 5500
546	0. 00000E+00	0. 00000E+00	4. 5500
547	0. 00000E+00	0. 00000E+00	4. 5500
548	0. 00000E+00	0. 00000E+00	4. 5500
549	0. 00000E+00	0. 00000E+00	4. 5500
580	0. 00000E+00	0. 00000E+00	5. 0500
581	0. 00000E+00	0. 00000E+00	5. 0500
582	0. 00000E+00	0. 00000E+00	5. 0500
583	0. 00000E+00	0. 00000E+00	5. 0500
584	0. 00000E+00	0. 00000E+00	5. 0500
585	0. 00000E+00	0. 00000E+00	5. 0500
586	0. 00000E+00	0. 00000E+00	5. 0500
587	0. 00000E+00	0. 00000E+00	5. 0500
588	0. 00000E+00	0. 00000E+00	5. 0500
589	0. 00000E+00	0. 00000E+00	5. 0500
620	0. 00000E+00	0. 00000E+00	5. 5800
621	0. 00000E+00	0. 00000E+00	5. 5800
622	0. 00000E+00	0. 00000E+00	5. 5800
623	0. 00000E+00	0. 00000E+00	5. 5800
624	0. 00000E+00	0. 00000E+00	5. 5800
625	0. 00000E+00	0. 00000E+00	5. 5800

TABLE 2 (Con't)

LIST OF NODES

<u>NODE</u>	<u>X</u>	<u>Y</u>	<u>Z</u>
626	0. 00000E+00	0. 00000E+00	5. 5800
627	0. 00000E+00	0. 00000E+00	5. 5800
628	0. 00000E+00	0. 00000E+00	5. 5800
629	0. 00000E+00	0. 00000E+00	5. 5800
660	0. 00000E+00	0. 00000E+00	6. 1400
661	0. 00000E+00	0. 00000E+00	6. 1400
662	0. 00000E+00	0. 00000E+00	6. 1400
663	0. 00000E+00	0. 00000E+00	6. 1400
664	0. 00000E+00	0. 00000E+00	6. 1400
665	0. 00000E+00	0. 00000E+00	6. 1400
666	0. 00000E+00	0. 00000E+00	6. 1400
667	0. 00000E+00	0. 00000E+00	6. 1400
668	0. 00000E+00	0. 00000E+00	6. 1400
669	0. 00000E+00	0. 00000E+00	6. 1400
700	0. 00000E+00	0. 00000E+00	6. 4600
701	0. 00000E+00	0. 00000E+00	6. 4600
702	0. 00000E+00	0. 00000E+00	6. 4600
703	0. 00000E+00	0. 00000E+00	6. 4600
704	0. 00000E+00	0. 00000E+00	6. 4600
705	0. 00000E+00	0. 00000E+00	6. 4600
706	0. 00000E+00	0. 00000E+00	6. 4600
707	0. 00000E+00	0. 00000E+00	6. 4600
708	0. 00000E+00	0. 00000E+00	6. 4600
709	0. 00000E+00	0. 00000E+00	6. 4600

TABLE 2 (Con't)

LIST OF NODES

<u>NODE</u>	<u>X</u>	<u>Y</u>	<u>Z</u>
740	0. 65000	0. 00000E+00	6. 4600
741	0. 65000	0. 00000E+00	6. 4600
742	0. 65000	0. 00000E+00	6. 4600
743	0. 65000	0. 00000E+00	6. 4600
744	0. 65000	0. 00000E+00	6. 4600
745	0. 65000	0. 00000E+00	6. 4600
746	0. 65000	0. 00000E+00	6. 4600
747	0. 65000	0. 00000E+00	6. 4600
748	0. 65000	0. 00000E+00	6. 4600
749	0. 65000	0. 00000E+00	6. 4600
751	0. 23750	0. 00000E+00	0. 50000
752	0. 19214	0. 13960	0. 50000
753	0. 73392E-01	0. 22588	0. 50000
754	-0. 73392E-01	0. 22588	0. 50000
755	-0. 19214	0. 13960	0. 50000
756	-0. 23750	0. 41452E-05	0. 50000
757	-0. 19214	-0. 13960	0. 50000
758	-0. 73392E-01	-0. 22588	0. 50000
759	0. 73392E-01	-0. 22588	0. 50000
760	0. 19214	-0. 13960	0. 50000
770	0. 00000E+00	0. 00000E+00	0. 50000
771	0. 00000E+00	0. 00000E+00	0. 50000
772	0. 00000E+00	0. 00000E+00	0. 50000
773	0. 00000E+00	0. 00000E+00	0. 50000

TABLE 2 (Con't)

LIST OF NODES

<u>NODE</u>	<u>X</u>	<u>Y</u>	<u>Z</u>
774	0. 00000E+00	0. 00000E+00	0. 50000
775	0. 00000E+00	0. 00000E+00	0. 50000
776	0. 00000E+00	0. 00000E+00	0. 50000
777	0. 00000E+00	0. 00000E+00	0. 50000
778	0. 00000E+00	0. 00000E+00	0. 50000
779	0. 00000E+00	0. 00000E+00	0. 50000
800	0. 00000E+00	0. 00000E+00	0. 00000E+00
801	0. 00000E+00	0. 00000E+00	0. 00000E+00
802	0. 00000E+00	0. 00000E+00	0. 00000E+00
803	0. 00000E+00	0. 00000E+00	0. 00000E+00
804	0. 00000E+00	0. 00000E+00	0. 00000E+00
805	0. 00000E+00	0. 00000E+00	0. 00000E+00
806	0. 00000E+00	0. 00000E+00	0. 00000E+00
807	0. 00000E+00	0. 00000E+00	0. 00000E+00
808	0. 00000E+00	0. 00000E+00	0. 00000E+00
809	0. 00000E+00	0. 00000E+00	0. 00000E+00
850	1. 1000	0. 00000E+00	6. 3100
851	1. 2400	0. 00000E+00	6. 2100
852	6. 0934	-2. 1974	9. 9460
871	1. 3082	0. 68560E-01	6. 1800
872	1. 1449	0. 28547	6. 2500
873	0. 94373	0. 46029	6. 3500
874	0. 73724	0. 51622	6. 4500
875	0. 50185	0. 55736	6. 5500

TABLE 2 (Con't)

LIST OF NODES

<u>NODE</u>	<u>X</u>	<u>Y</u>	<u>Z</u>
876	0. 38000	0. 00000E+00	6. 6500
877	0. 55736	-0. 50185	6. 5500
878	0. 77942	-0. 45000	6. 4500
879	0. 98668	-0. 35912	6. 3500
880	1. 1685	-0. 16422	6. 2500
900	-0. 22000	0. 38397E-05	6. 6400
901	-0. 22000	0. 38397E-05	6. 6400
902	-0. 22000	0. 38397E-05	6. 6400
903	-0. 22000	0. 38397E-05	6. 6400
904	-0. 22000	0. 38397E-05	6. 6400
905	-0. 22000	0. 38397E-05	6. 6400
906	-0. 22000	0. 38397E-05	6. 6400
907	-0. 22000	0. 38397E-05	6. 6400
908	-0. 22000	0. 38397E-05	6. 6400
909	-0. 22000	0. 38397E-05	6. 6400
910	-0. 92705E-01	0. 28532	7. 6300
911	-0. 32361	0. 23511	7. 7000
912	-0. 50000	0. 87267E-05	7. 6100
913	-0. 32361	-0. 23511	7. 7000
914	-0. 92705E-01	-0. 28532	7. 6300
915	-0. 22000	0. 38397E-05	7. 6100
920	-0. 11125	0. 34238	7. 6300
921	-0. 37215	0. 27038	7. 7000
922	-0. 56000	0. 97738E-05	7. 6100

TABLE 2 (Con't)

LIST OF NODES

<u>NODE</u>	<u>X</u>	<u>Y</u>	<u>Z</u>
923	-0. 37215	-0. 27038	7. 7000
924	-0. 11125	-0. 34238	7. 6300
925	-0. 22000	0. 38397E-05	7. 6100
935	-0. 22000	0. 38397E-05	7. 6100
940	-0. 22000	0. 38397E-05	7. 6100
941	-0. 22000	0. 38397E-05	7. 6100
942	-0. 22000	0. 38397E-05	7. 6100
943	-0. 22000	0. 38397E-05	7. 6100
944	-0. 22000	0. 38397E-05	7. 6100
945	-0. 22000	0. 38397E-05	7. 6100
946	-0. 22000	0. 38397E-05	7. 6100
947	-0. 22000	0. 38397E-05	7. 6100
948	-0. 22000	0. 38397E-05	7. 6100
949	-0. 22000	0. 38397E-05	7. 6100
955	-0. 22000	0. 38397E-05	7. 6100
965	-0. 22000	0. 38397E-05	7. 6100
971	1. 1100	0. 00000E+00	6. 1800
972	0. 96199	0. 18699	6. 2500
973	0. 78243	0. 33212	6. 3500
974	0. 59363	0. 37094	6. 4500
975	0. 38891	0. 38891	6. 5500
976	0. 38000	0. 00000E+00	6. 6500
977	0. 38891	-0. 38891	6. 5500
978	0. 58707	-0. 38125	6. 4500

TABLE 2 (Con't)

LIST OF NODES

<u>NODE</u>	<u>X</u>	<u>Y</u>	<u>Z</u>
979	0. 78243	-0. 33212	6. 3500
980	0. 96199	-0. 18699	6. 2500
981	1. 3600	0. 00000E+00	6. 1800
982	1. 2074	0. 23470	6. 2500
983	1. 0126	0. 42980	6. 3500
984	0. 80565	0. 50342	6. 4500
985	0. 56569	0. 56569	6. 5500
986	0. 63000	0. 00000E+00	6. 6500
987	0. 56569	-0. 56569	6. 5500
988	0. 79674	-0. 51741	6. 4500
989	1. 0126	-0. 42980	6. 3500
990	1. 2074	-0. 23470	6. 2500
991	1. 4200	0. 00000E+00	6. 1800
992	1. 2663	0. 24614	6. 2500
993	1. 0678	0. 45325	6. 3500
994	0. 85653	0. 53522	6. 4500
995	0. 60811	0. 60811	6. 5500
996	0. 69000	0. 00000E+00	6. 6500
997	0. 60811	-0. 60811	6. 5500
998	0. 84706	-0. 55009	6. 4500
999	1. 0678	-0. 45325	6. 3500
1000	1. 2663	-0. 24614	6. 2500
1005	-0. 22000	0. 38397E-05	7. 6100
1998	0. 85000	0. 00000E+00	6. 3500



TABLE 2 (Con't)

LIST OF NODES

<u>NODE</u>	<u>X</u>	<u>Y</u>	<u>Z</u>
1999	0. 78000	0. 53000	6. 3500
2001	1. 3500	0. 00000E+00	6. 1800
2002	1. 1700	0. 30000	6. 2500
2003	0. 85000	0. 50000	6. 3500
2004	0. 70000	0. 55000	6. 4500
2005	0. 48000	0. 57000	6. 5500
2006	0. 38000	0. 00000E+00	6. 6500
2007	0. 48000	-0. 57000	6. 5500
2008	0. 70000	-0. 55000	6. 4500
2009	0. 85000	-0. 50000	6. 3500
2010	1. 1700	-0. 30000	6. 2500
2011	1. 3886	0. 50972E-02	6. 2935
2012	1. 2086	0. 30510	6. 3635
2013	0. 88859	0. 50510	6. 4635
2014	0. 73859	0. 55510	6. 5635
2015	0. 51859	0. 57510	6. 6635
2016	0. 41859	0. 50972E-02	6. 7635
2017	0. 51859	-0. 56490	6. 6635
2018	0. 73859	-0. 54490	6. 5635
2019	0. 88859	-0. 49490	6. 4635
2020	1. 2086	-0. 29490	6. 3635
2021	0. 85000	0. 00000E+00	6. 3500
2022	0. 85000	0. 00000E+00	6. 3500
2023	0. 85000	0. 00000E+00	6. 3500

TABLE 2 (Con't)

LIST OF NODES

<u>NODE</u>	<u>X</u>	<u>Y</u>	<u>Z</u>
2024	0. 85000	0. 00000E+00	6. 3500
2025	0. 85000	0. 00000E+00	6. 3500
2026	0. 85000	0. 00000E+00	6. 3500
2027	0. 85000	0. 00000E+00	6. 3500
2028	0. 85000	0. 00000E+00	6. 3500
2029	0. 85000	0. 00000E+00	6. 3500
2030	0. 85000	0. 00000E+00	6. 3500
2031	0. 88859	0. 50972E-02	6. 4635
2032	0. 88859	0. 50972E-02	6. 4635
2033	0. 88859	0. 50972E-02	6. 4635
2034	0. 88859	0. 50972E-02	6. 4635
2035	0. 88859	0. 50972E-02	6. 4635
2036	0. 88859	0. 50972E-02	6. 4635
2037	0. 88859	0. 50972E-02	6. 4635
2038	0. 88859	0. 50972E-02	6. 4635
2039	0. 88859	0. 50972E-02	6. 4635
2040	0. 88859	0. 50972E-02	6. 4635
2050	1. 1537	0. 50972E-02	6. 3734
2051	1. 1008	0. 16953	6. 3840
2052	0. 96687	0. 27115	6. 4249
2053	0. 80303	0. 27115	6. 4807
2054	0. 67188	0. 16953	6. 5298
2055	0. 62350	0. 51021E-02	6. 5536
2056	0. 67638	-0. 15933	6. 5430

TABLE 2 (Con't)

LIST OF NODES

<u>NODE</u>	<u>X</u>	<u>Y</u>	<u>Z</u>
2057	0. 81032	-0. 26096	6. 5021
2058	0. 97415	-0. 26096	6. 4464
2059	1. 1053	-0. 15933	6. 3972
2060	1. 2783	0. 27185E-01	6. 8797
2061	1. 2339	0. 16519	6. 8886
2062	1. 1215	0. 25048	6. 9230
2063	0. 98402	0. 25048	6. 9698
2064	0. 87394	0. 16519	7. 0110
2065	0. 83334	0. 27189E-01	7. 0310
2066	0. 87772	-0. 11082	7. 0221
2067	0. 99013	-0. 19611	6. 9878
2068	1. 1276	-0. 19611	6. 9410
2069	1. 2377	-0. 11082	6. 8997
2071	1. 0558	0. 27185E-01	6. 9554
2072	1. 0558	0. 27185E-01	6. 9554
2073	1. 0558	0. 27185E-01	6. 9554
2074	1. 0558	0. 27185E-01	6. 9554
2075	1. 0558	0. 27185E-01	6. 9554
2076	1. 0558	0. 27185E-01	6. 9554
2077	1. 0558	0. 27185E-01	6. 9554
2078	1. 0558	0. 27185E-01	6. 9554
2079	1. 0558	0. 27185E-01	6. 9554
2080	1. 0558	0. 27185E-01	6. 9554
3000	1. 4031	0. 28035E-01	6. 8584

TABLE 2 (Con't)

LIST OF NODES

<u>NODE</u>	<u>X</u>	<u>Y</u>	<u>Z</u>
3001	1. 3351	0. 23945	6. 8720
3002	1. 1629	0. 37011	6. 9247
3003	0. 95226	0. 37011	6. 9963
3004	0. 78363	0. 23945	7. 0595
3005	0. 72143	0. 28041E-01	7. 0902
3006	0. 78941	-0. 18338	7. 0766
3007	0. 96162	-0. 31404	7. 0239
3008	1. 1723	-0. 31404	6. 9523
3009	1. 3409	-0. 18338	6. 8891
3011	1. 2424	0. 51822E-01	7. 5040
3012	1. 2424	0. 51822E-01	7. 5040
3013	1. 2424	0. 51822E-01	7. 5040
3014	1. 2424	0. 51822E-01	7. 5040
3015	1. 2424	0. 51822E-01	7. 5040
3016	1. 2424	0. 51822E-01	7. 5040
3017	1. 2424	0. 51822E-01	7. 5040
3018	1. 2424	0. 51822E-01	7. 5040
3019	1. 2424	0. 51822E-01	7. 5040
3020	1. 2424	0. 51822E-01	7. 5040
3040	1. 8341	0. 51822E-01	7. 5040
3041	1. 7161	0. 41886	7. 3265
3042	1. 4171	0. 64570	7. 4179
3043	1. 0514	0. 64570	7. 5423
3044	0. 75862	0. 41886	7. 6520

TABLE 2 (Con't)

LIST OF NODES

<u>NODE</u>	<u>X</u>	<u>Y</u>	<u>Z</u>
3045	0. 65063	0. 51833E-01	7. 7052
3046	0. 76867	-0. 31521	7. 6816
3047	1. 0676	-0. 54205	7. 5901
3048	1. 4334	-0. 54205	7. 4658
3049	1. 7261	-0. 31521	7. 3560
3051	1. 4096	0. 73910E-01	7. 9959
3052	1. 4096	0. 73910E-01	7. 9959
3053	1. 4096	0. 73910E-01	7. 9959
3054	1. 4096	0. 73910E-01	7. 9959
3055	1. 4096	0. 73910E-01	7. 9959
3056	1. 4096	0. 73910E-01	7. 9959
3057	1. 4096	0. 73910E-01	7. 9959
3058	1. 4096	0. 73910E-01	7. 9959
3059	1. 4096	0. 73910E-01	7. 9959
3060	1. 4096	0. 73910E-01	7. 9959
3080	1. 7126	0. 73910E-01	7. 8929
3081	1. 6521	0. 26183	7. 9050
3082	1. 4991	0. 37797	7. 9518
3083	1. 3118	0. 37797	8. 0155
3084	1. 1619	0. 26183	8. 0717
3085	1. 1066	0. 73916E-01	8. 0989
3086	1. 1671	-0. 11401	8. 0868
3087	1. 3201	-0. 23015	8. 0400
3088	1. 5074	-0. 23015	7. 9763

TABLE 2 (Con't)

LIST OF NODES

<u>NODE</u>	<u>X</u>	<u>Y</u>	<u>Z</u>
3089	1. 6573	-0. 11401	7. 9201
3091	1. 4482	0. 79007E-01	8. 1094
3092	1. 4482	0. 79007E-01	8. 1094
3093	1. 4482	0. 79007E-01	8. 1094
3094	1. 4482	0. 79007E-01	8. 1094
3095	1. 4482	0. 79007E-01	8. 1094
3096	1. 4482	0. 79007E-01	8. 1094
3097	1. 4482	0. 79007E-01	8. 1094
3098	1. 4482	0. 79007E-01	8. 1094
3099	1. 4482	0. 79007E-01	8. 1094
3100	1. 4482	0. 79007E-01	8. 1094
4020	1. 5743	0. 78158E-01	8. 0454
4021	1. 5479	0. 16037	8. 0507
4022	1. 4809	0. 21119	8. 0712
4023	1. 3990	0. 21119	8. 0991
4024	1. 3334	0. 16037	8. 1236
4025	1. 3092	0. 78160E-01	8. 1356
4026	1. 3357	-0. 40578E-02	8. 1303
4027	1. 4026	-0. 54870E-01	8. 1098
4028	1. 4845	-0. 54807E-01	8. 0819
4029	1. 5501	-0. 40578E-02	8. 0573

TABLE 3  
LIST OF ELEMENTS

<u>ELEMENT</u>	<u>MATERIAL</u>	<u>NODES</u>								
1	1	1	11	12	2	31	41	42	32	
2	1	2	12	13	3	32	42	43	33	
3	1	3	13	14	4	33	43	44	34	
4	1	4	14	15	5	34	44	45	35	
5	1	5	15	16	6	35	45	46	36	
6	1	6	16	17	7	36	46	47	37	
7	1	7	17	18	8	37	47	48	38	
8	1	8	18	19	9	38	48	49	39	
9	1	9	19	20	10	39	49	50	40	
10	1	1	10	20	11	31	40	50	41	
11	1	31	41	42	32	61	71	72	62	
12	1	32	42	43	33	62	72	73	63	
13	1	33	43	44	34	63	73	74	64	
14	1	34	44	45	35	64	74	75	65	
15	1	35	45	46	36	65	75	76	66	
16	1	36	46	47	37	66	76	77	67	
17	1	37	47	48	38	67	77	78	68	
18	1	38	48	49	39	68	78	79	69	
19	1	39	49	50	40	69	79	80	70	
20	1	31	40	50	41	61	70	80	71	
21	1	61	71	72	62	91	101	102	92	
22	1	62	72	73	63	92	102	103	93	
23	1	63	73	74	64	93	103	104	94	
24	1	64	74	75	65	94	104	105	95	

TABLE 3 (Con't)

LIST OF ELEMENTS

<u>ELEMENT</u>	<u>MATERIAL</u>	<u>NODES</u>							
25	1	65	75	76	66	95	105	106	96
26	1	66	76	77	67	96	106	107	97
27	1	67	77	78	68	97	107	108	98
28	1	68	78	79	69	98	108	109	99
29	1	69	79	80	70	99	109	110	100
30	1	61	70	80	71	91	100	110	101
31	2	12	11	21	22	42	41	51	52
32	2	13	12	22	23	43	42	52	53
33	2	14	13	23	24	44	43	53	54
34	2	15	14	24	25	45	44	54	55
35	2	16	15	25	26	46	45	55	56
36	2	17	16	26	27	47	46	56	57
37	2	18	17	27	28	48	47	57	58
38	2	19	18	28	29	49	48	58	59
39	2	20	19	29	30	50	49	59	60
40	2	11	20	30	21	41	50	60	51
41	2	42	41	51	52	72	71	81	82
42	2	43	42	52	53	73	72	82	83
43	2	44	43	53	54	74	73	83	84
44	2	45	44	54	55	75	74	84	85
45	2	46	45	55	56	76	75	85	86
46	2	47	46	56	57	77	76	86	87
47	2	48	47	57	58	78	77	87	88
48	2	49	48	58	59	79	78	88	89



TABLE 3 (Con't)

LIST OF ELEMENTS

<u>ELEMENT</u>	<u>MATERIAL</u>	<u>NODES</u>							
49	2	50	49	59	60	80	79	89	90
50	2	41	50	60	51	71	80	90	81
51	2	72	71	81	82	102	101	111	112
52	2	73	72	82	83	103	102	112	113
53	2	74	73	83	84	104	103	113	114
54	2	75	74	84	85	105	104	114	115
55	2	76	75	85	86	106	105	115	116
56	2	77	76	86	87	107	106	116	117
57	2	78	77	87	88	108	107	117	118
58	2	79	78	88	89	109	108	118	119
59	2	80	79	89	90	110	109	119	120
60	2	71	80	90	81	101	110	120	111
61	1	92	91	101	102	132	131	141	142
62	1	93	92	102	103	133	132	142	143
63	1	94	93	103	104	134	133	143	144
64	1	95	94	104	105	135	134	144	145
65	1	96	95	105	106	136	135	145	146
66	1	97	96	106	107	137	136	146	147
67	1	98	97	107	108	138	137	147	148
68	1	99	98	108	109	139	138	148	149
69	1	100	99	109	110	140	139	149	150
70	1	91	100	110	101	131	140	150	141
71	1	132	131	141	142	172	171	181	182
72	1	133	132	142	143	173	172	182	183

TABLE 3 (Con't)

LIST OF ELEMENTS

<u>ELEMENT</u>	<u>MATERIAL</u>	<u>NODES</u>								
73	1	134	133	143	144	174	173	183	184	
74	1	135	134	144	145	175	174	184	185	
75	1	136	135	145	146	176	175	185	186	
76	1	137	136	146	147	177	176	186	187	
77	1	138	137	147	148	178	177	187	188	
78	1	139	138	148	149	179	178	188	189	
79	1	140	139	149	150	180	179	189	190	
80	1	131	140	150	141	171	180	190	181	
81	1	172	171	181	182	212	211	221	222	
82	1	173	172	182	183	213	212	222	223	
83	1	174	173	183	184	214	213	223	224	
84	1	175	174	184	185	215	214	224	225	
85	1	176	175	185	186	216	215	225	226	
86	1	177	176	186	187	217	216	226	227	
87	1	178	177	187	188	218	217	227	228	
88	1	179	178	188	189	219	218	228	229	
89	1	180	179	189	190	220	219	229	230	
90	1	171	180	190	181	211	220	230	221	
91	1	212	211	221	222	252	251	261	262	
92	1	213	212	222	223	253	252	262	263	
93	1	214	213	223	224	254	253	263	264	
94	1	215	214	224	225	255	254	264	265	
95	1	216	215	225	226	256	255	265	266	
96	1	217	216	226	227	257	256	266	267	

TABLE 3 (Con't)

LIST OF ELEMENTS

<u>ELEMENT</u>	<u>MATERIAL</u>	<u>NODES</u>							
97	1	218	217	227	228	258	257	267	268
98	1	219	218	228	229	259	258	268	269
99	1	220	219	229	230	260	259	269	270
100	1	211	220	230	221	251	260	270	261
101	1	252	251	261	262	292	291	301	302
102	1	253	252	262	263	293	292	302	303
103	1	254	253	263	264	294	293	303	304
104	1	255	254	264	265	295	294	304	305
105	1	256	255	265	266	296	295	305	306
106	1	257	256	266	267	297	296	306	307
107	1	258	257	267	268	298	297	307	308
108	1	259	258	268	269	299	298	308	309
109	1	260	259	269	270	300	299	309	310
110	1	251	260	270	261	291	300	310	301
111	1	292	291	301	302	332	331	341	342
112	1	293	292	302	303	333	332	342	343
113	1	294	293	303	304	334	333	343	344
114	1	295	294	304	305	335	334	344	345
115	1	296	295	305	306	336	335	345	346
116	1	297	296	306	307	337	336	346	347
117	1	298	297	307	308	338	337	347	348
118	1	299	298	308	309	339	338	348	349
119	1	300	299	309	310	340	339	349	350
120	1	291	300	310	301	331	340	350	341

TABLE 3 (Con't)

LIST OF ELEMENTS

<u>ELEMENT</u>	<u>MATERIAL</u>	<u>NODES</u>								
121	3	102	101	121	122	142	141	161	162	
122	3	103	102	122	123	143	142	162	163	
123	3	104	103	123	124	144	143	163	164	
124	3	105	104	124	125	145	144	164	165	
125	3	106	105	125	126	146	145	165	166	
126	3	107	106	126	127	147	146	166	167	
127	3	108	107	127	128	148	147	167	168	
128	3	109	108	128	129	149	148	168	169	
129	3	110	109	129	130	150	149	169	170	
130	3	101	110	130	121	141	150	170	161	
131	3	142	141	161	162	182	181	201	202	
132	3	143	142	162	163	183	182	202	203	
133	3	144	143	163	164	184	183	203	204	
134	3	145	144	164	165	185	184	204	205	
135	3	146	145	165	166	186	185	205	206	
136	3	147	146	166	167	187	186	206	207	
137	3	148	147	167	168	188	187	207	208	
138	3	149	148	168	169	189	188	208	209	
139	3	150	149	169	170	190	189	209	210	
140	3	141	150	170	161	181	190	210	201	
141	3	182	181	201	202	222	221	241	242	
142	3	183	182	202	203	223	222	242	243	
143	3	184	183	203	204	224	223	243	244	
144	3	185	184	204	205	225	224	244	245	

TABLE 3 (Con't)

LIST OF ELEMENTS

<u>ELEMENT</u>	<u>MATERIAL</u>	<u>NODES</u>							
145	3	186	185	205	206	226	225	245	246
146	3	187	186	206	207	227	226	246	247
147	3	188	187	207	208	228	227	247	248
148	3	189	188	208	209	229	228	248	249
149	3	190	189	209	210	230	229	249	250
150	3	181	190	210	201	221	230	250	241
151	3	222	221	241	242	262	261	281	282
152	3	223	222	242	243	263	262	282	283
153	3	224	223	243	244	264	263	283	284
154	3	225	224	244	245	265	264	284	285
155	3	226	225	245	246	266	265	285	286
156	3	227	226	246	247	267	266	286	287
157	3	228	227	247	248	268	267	287	288
158	3	229	228	248	249	269	268	288	289
159	3	230	229	249	250	270	269	289	290
160	3	221	230	250	241	261	270	290	
161	3	262	261	281	282	302	301	321	
162	3	263	262	282	283	303	302	322	
163	3	264	263	283	284	304	303	323	324
164	3	265	264	284	285	305	304		
165	3	266	265	285	286	306	305		
166	3	267	266	286	287	307	306		
167	3	268	267	287	288	308	307		
168	3	269	268	288	289	309	308		

TABLE 3 (Con't)

LIST OF ELEMENTS

<u>ELEMENT</u>	<u>MATERIAL</u>	<u>NODES</u>								
169	3	270	269	289	290	310	309	329	330	
170	3	261	270	290	281	301	310	330	321	
171	3	302	301	321	322	342	341	361	362	
172	3	303	302	322	323	343	342	362	363	
173	3	304	303	323	324	344	343	363	364	
174	3	305	304	324	325	345	344	364	365	
175	3	306	305	325	326	346	345	365	366	
176	3	307	306	326	327	347	346	366	367	
177	3	308	307	327	328	348	347	367	368	
178	3	309	308	328	329	349	348	368	369	
179	3	310	309	329	330	350	349	369	370	
180	3	301	310	330	321	341	350	370	361	
181	4	122	121	111	112	162	161	151	152	
182	4	123	122	112	113	163	162	152	153	
183	4	124	123	113	114	164	163	153	154	
184	4	125	124	114	115	165	164	154	155	
185	4	126	125	115	116	166	165	155	156	
186	4	127	126	116	117	167	166	156	157	
187	4	128	127	117	118	168	167	157	158	
188	4	129	128	118	119	169	168	158	159	
189	4	130	129	119	120	170	169	159	160	
190	4	121	130	120	111	161	170	160	151	
191	4	162	161	151	152	202	201	191	192	
192	4	163	162	152	153	203	202	192	193	

TABLE 3 (Con't)

LIST OF ELEMENTS

<u>ELEMENT</u>	<u>MATERIAL</u>	<u>NODES</u>							
193	4	164	163	153	154	204	203	193	194
194	4	165	164	154	155	205	204	194	195
195	4	166	165	155	156	206	205	195	196
196	4	167	166	156	157	207	206	196	197
197	4	168	167	157	158	208	207	197	198
198	4	169	168	158	159	209	208	198	199
199	4	170	169	159	160	210	209	199	
200	4	161	170	160	151	201	210	200	
201	4	202	201	191	192	242	241	231	
202	4	203	202	192	193	243	242	232	2
203	4	204	203	193	194	244	243	233	234
204	4	205	204	194	195	245	244	234	235
205	4	206	205	195	196	246	245	235	236
206	4	207	206	196	197	247	246	236	237
207	4	208	207	197	198	248	247	237	238
208	4	209	208	198	199	249	248	238	239
209	4	210	209	199	200	250	249	239	240
210	4	201	210	200	191	241	250	240	231
211	4	242	241	231	232	282	281	271	27
212	4	243	242	232	233	283	282	272	27
213	4	244	243	233	234	284	283	273	27
214	4	245	244	234	235	285	284	274	
215	4	246	245	235	236	286	285	275	
216	4	247	246	236	237	287	286	276	

TABLE 3 (Con't)

LIST OF ELEMENTS

<u>ELEMENT</u>	<u>MATERIAL</u>	<u>NODES</u>							
217	4	248	247	237	238	288	287	277	278
218	4	249	248	238	239	289	288	278	279
219	4	250	249	239	240	290	289	279	280
220	4	241	250	240	231	281	290	280	271
221	4	282	281	271	272	322	321	311	312
222	4	283	282	272	273	323	322	312	313
223	4	284	283	273	274	324	323	313	314
224	4	285	284	274	275	325	324	314	315
225	4	286	285	275	276	326	325	315	316
226	4	287	286	276	277	327	326	316	317
227	4	288	287	277	278	328	327	317	318
228	4	289	288	278	279	329	328	318	319
229	4	290	289	279	280	330	329	319	320
230	4	281	290	280	271	321	330	320	311
231	4	322	321	311	312	362	361	351	352
232	4	323	322	312	313	363	362	352	353
233	4	324	323	313	314	364	363	353	354
234	4	325	324	314	315	365	364	354	355
235	4	326	325	315	316	366	365	355	356
236	4	327	326	316	317	367	366	356	357
237	4	328	327	317	318	368	367	357	358
238	4	329	328	318	319	369	368	358	359
239	4	330	329	319	320	370	369	359	360
240	4	321	330	320	311	361	370	360	351



TABLE 3 (Con't)

LIST OF ELEMENTS

<u>ELEMENT</u>	<u>MATERIAL</u>	<u>NODES</u>							
241	1	332	331	341	342	372	371	381	382
242	1	333	332	342	343	373	372	382	383
243	1	334	333	343	344	374	373	383	384
244	1	335	334	344	345	375	374	384	385
245	1	336	335	345	346	376	375	385	386
246	1	337	336	346	347	377	376	386	387
247	1	338	337	347	348	378	377	387	388
248	1	339	338	348	349	379	378	388	389
249	1	340	339	349	350	380	379	389	390
250	1	331	340	350	341	371	380	390	381
251	5	401	400	31	32	431	430	61	62
252	5	402	401	32	33	432	431	62	63
253	5	403	402	33	34	433	432	63	64
254	5	404	403	34	35	434	433	64	65
255	5	405	404	35	36	435	434	65	66
256	5	406	405	36	37	436	435	66	67
257	5	407	406	37	38	437	436	67	68
258	5	408	407	38	39	438	437	68	69
259	5	409	408	39	40	439	438	69	70
260	5	400	409	40	31	430	439	70	61
261	5	431	430	61	62	461	460	91	92
262	5	432	431	62	63	462	461	92	93
263	5	433	432	63	64	463	462	93	94
264	5	434	433	64	65	464	463	94	95

TABLE 3 (Con't)

LIST OF ELEMENTS

<u>ELEMENT</u>	<u>MATERIAL</u>	<u>NODES</u>								
265	5	435	434	65	66	465	464	95	96	
266	5	436	435	66	67	466	465	96	97	
267	5	437	436	67	68	467	466	97	98	
268	5	438	437	68	69	468	467	98	99	
269	5	439	438	69	70	469	468	99	100	
270	5	430	439	70	61	460	469	100	91	
271	5	461	460	91	92	501	500	131	132	
272	5	462	461	92	93	502	501	132	133	
273	5	463	462	93	94	503	502	133	134	
274	5	464	463	94	95	504	503	134	135	
275	5	465	464	95	96	505	504	135	136	
276	5	466	465	96	97	506	505	136	137	
277	5	467	466	97	98	507	506	137	138	
278	5	468	467	98	99	508	507	138	139	
279	5	469	468	99	100	509	508	139	140	
280	5	460	469	100	91	500	509	140	131	
281	5	501	500	131	132	541	540	171	172	
282	5	502	501	132	133	542	541	172	173	
283	5	503	502	133	134	543	542	173	174	
284	5	504	503	134	135	544	543	174	175	
285	5	505	504	135	136	545	544	175	176	
286	5	506	505	136	137	546	545	176	177	
287	5	507	506	137	138	547	546	177	178	
288	5	508	507	138	139	548	547	178	179	

TABLE 3 (Con't)

LIST OF ELEMENTS

<u>ELEMENT</u>	<u>MATERIAL</u>	<u>NODES</u>							
289	5	509	508	139	140	549	548	179	180
290	5	500	509	140	131	540	549	180	171
291	5	541	540	171	172	581	580	211	212
292	5	542	541	172	173	582	581	212	213
293	5	543	542	173	174	583	582	213	214
294	5	544	543	174	175	584	583	214	215
295	5	545	544	175	176	585	584	215	216
296	5	546	545	176	177	586	585	216	217
297	5	547	546	177	178	587	586	217	218
298	5	548	547	178	179	588	587	218	219
299	5	549	548	179	180	589	588	219	220
300	5	540	549	180	171	580	589	220	211
301	5	581	580	211	212	621	620	251	252
302	5	582	581	212	213	622	621	252	253
303	5	583	582	213	214	623	622	253	254
304	5	584	583	214	215	624	623	254	255
305	5	585	584	215	216	625	624	255	256
306	5	586	585	216	217	626	625	256	257
307	5	587	586	217	218	627	626	257	258
308	5	588	587	218	219	628	627	258	259
309	5	589	588	219	220	629	628	259	260
310	5	580	589	220	211	630	629	260	261
311	5	621	620	251	252	661	660	291	292
312	5	622	621	252	253	662	661	292	293

TABLE 3 (Con't)

LIST OF ELEMENTS

<u>ELEMENT</u>	<u>MATERIAL</u>	<u>NODES</u>							
313	5	623	622	253	254	663	662	293	294
314	5	624	623	254	255	664	663	294	295
315	5	625	624	255	256	665	664	295	296
316	5	626	625	256	257	666	665	296	297
317	5	627	626	257	258	667	666	297	298
318	5	628	627	258	259	668	667	298	299
319	5	629	628	259	260	669	668	299	300
320	5	620	629	260	251	660	669	300	291
321	5	661	660	291	292	701	700	331	332
322	5	662	661	292	293	702	701	332	333
323	5	663	662	293	294	703	702	333	334
324	5	664	663	294	295	704	703	334	335
325	5	665	664	295	296	705	704	335	336
326	5	666	665	296	297	706	705	336	337
327	5	667	666	297	298	707	706	337	338
328	5	668	667	298	299	708	707	338	339
329	5	669	668	299	300	709	708	339	340
330	5	660	669	300	291	700	709	340	331
331	5	701	700	331	332	741	740	371	372
332	5	702	701	332	333	742	741	372	373
333	5	703	702	333	334	743	742	373	374
334	5	704	703	334	335	744	743	374	375
335	5	705	704	335	336	745	744	375	376
336	5	706	705	336	337	746	745	376	377

TABLE 3 (Con't)

LIST OF ELEMENTS

<u>ELEMENT</u>	<u>MATERIAL</u>	<u>NODES</u>							
337	5	707	706	337	338	747	746	377	378
338	5	708	707	338	339	748	747	378	379
339	5	709	708	339	340	749	748	379	380
340	5	700	709	340	331	740	749	380	371
341	5	771	770	751	752	401	400	31	32
342	5	772	771	752	753	402	401	32	33
343	5	773	772	753	754	403	402	33	34
344	5	774	773	754	755	404	403	34	35
345	5	775	774	755	756	405	404	35	36
346	5	776	775	756	757	406	405	36	37
347	5	777	776	757	758	407	406	37	38
348	5	778	777	758	759	408	407	38	39
349	5	779	778	759	760	409	408	39	40
350	5	770	779	760	751	400	409	40	31
351	1	801	800	1	2	771	770	751	752
352	1	802	801	2	3	772	771	752	753
353	1	803	802	3	4	773	772	753	754
354	1	804	803	4	5	774	773	754	755
355	1	805	804	5	6	775	774	755	756
356	1	806	805	6	7	776	775	756	757
357	1	807	806	7	8	777	776	757	758
358	1	808	807	8	9	778	777	758	759
359	1	809	808	9	10	779	778	759	760
360	1	800	809	10	1	770	779	760	751

TABLE 3 (Con't)

LIST OF ELEMENTS

<u>ELEMENT</u>	<u>MATERIAL</u>	<u>NODES</u>							
361	4	364	365	355	354	910	911	921	920
362	4	365	366	356	355	911	912	922	921
363	4	366	367	357	356	912	913	923	922
364	4	367	368	358	357	913	914	924	923
365	3	364	365	901	900	910	911	941	940
366	3	365	366	902	901	911	912	942	941
367	3	366	367	903	902	912	913	943	942
368	3	367	368	904	903	913	914	944	943
369	1	331	332	342	341	371	372	972	971
370	1	332	333	343	342	372	373	973	972
371	1	333	334	344	343	373	374	974	973
372	1	334	335	345	344	374	375	975	974
373	1	337	338	348	347	377	378	978	977
374	1	338	339	349	348	378	379	979	978
375	1	339	340	350	349	379	380	980	979
376	1	340	331	341	350	380	371	971	980
377	3	341	342	362	361	971	972	982	981
378	3	342	343	363	362	972	973	983	982
379	3	343	344	364	363	973	974	984	983
380	3	344	345	365	364	974	975	985	984
381	3	347	348	368	367	977	978	988	987
382	3	348	349	369	368	978	979	989	988
383	3	349	350	370	369	979	980	990	989
384	3	350	341	361	370	380	971	981	990

TABLE 3 (Con't)

LIST OF ELEMENTS

<u>ELEMENT</u>	<u>MATERIAL</u>	<u>NODES</u>							
385	4	361	362	352	351	981	982	992	991
386	4	362	363	353	352	982	983	993	992
387	4	363	364	354	353	983	984	994	993
388	4	364	365	355	354	984	985	995	994
389	4	367	368	358	357	987	988	998	997
390	4	368	369	359	358	988	989	999	998
391	4	369	370	360	359	989	990	1000	999
392	4	370	361	351	360	990	981	991	1000
393	5	2022	2021	2001	2002	2032	2031	2011	2012
394	5	2023	2022	2002	2003	2033	2032	2012	2013
395	5	2024	2023	2003	2004	2034	2033	2013	2014
396	5	2025	2024	2004	2005	2035	2034	2014	2015
397	5	2026	2025	2005	2006	2036	2035	2015	2016
398	5	2027	2026	2006	2007	2037	2036	2016	2017
399	5	2028	2027	2007	2008	2038	2037	2017	2018
400	5	2029	2028	2008	2009	2039	2038	2018	2019
401	5	2030	2029	2009	2010	2040	2039	2019	2020
402	5	2021	2030	2010	2001	2031	2040	2020	2011
403	5	2031	2032	2051	2050	2071	2072	2061	2060
404	5	2032	2033	2052	2051	2072	2073	2062	2061
405	5	2033	2034	2053	2052	2073	2074	2063	2062
406	5	2034	2035	2054	2053	2074	2075	2064	2063
407	5	2035	2036	2055	2054	2075	2076	2065	2064
408	5	2036	2037	2056	2055	2076	2077	2066	2065

TABLE 3 (Con't)

LIST OF ELEMENTS

<u>ELEMENT</u>	<u>MATERIAL</u>	<u>NODES</u>
409	5	2037 2038 2057 2056 2077 2078 2067 2066
410	5	2038 2039 2058 2057 2078 2079 2068 2067
411	5	2039 2040 2059 2058 2079 2080 2069 2068
412	5	2040 2031 2050 2059 2080 2071 2060 2069
413	5	2071 2072 3001 3000 3011 3012 3041 3040
414	5	2072 2073 3002 3001 3012 3013 3042 3041
415	5	2073 2074 3003 3002 3013 3014 3043 3042
416	5	2074 2075 3004 3003 3014 3015 3044 3043
417	5	2075 2076 3005 3004 3015 3016 3045 3044
418	5	2076 2077 3006 3005 3016 3017 3046 3045
419	5	2077 2078 3007 3006 3017 3018 3047 3046
420	5	2078 2079 3008 3007 3018 3019 3048 3047
421	5	2079 2080 3009 3008 3019 3020 3049 3048
422	5	2080 2071 3000 3009 3020 3011 3040 3049
423	5	3012 3011 3040 3041 3052 3051 3080 3081
424	5	3013 3012 3041 3042 3053 3052 3081 3082
425	5	3014 3013 3042 3043 3054 3053 3082 3083
426	5	3015 3014 3043 3044 3055 3054 3083 3084
427	5	3016 3015 3044 3045 3056 3055 3084 3085
428	5	3017 3016 3045 3046 3057 3056 3085 3086
429	5	3018 3017 3046 3047 3058 3057 3086 3087
430	5	3019 3018 3047 3048 3059 3058 3087 3088
431	5	3020 3019 3048 3049 3060 3059 3088 3089
432	5	3011 3020 3049 3040 3051 3060 3089 3080



TABLE 3 (Con't)

LIST OF ELEMENTS

<u>ELEMENT</u>	<u>MATERIAL</u>	<u>NODES</u>
433	5	3051 3052 3081 3080 3091 3092 4021 4020
434	5	3052 3053 3082 3081 3092 3093 4022 4021
435	5	3053 3054 3083 3082 3093 3094 4023 4022
436	5	3054 3055 3084 3083 3094 3095 4024 4023
437	5	3055 3056 3085 3084 3095 3096 4025 4024
438	5	3056 3057 3086 3085 3096 3097 4026 4025
439	5	3057 3058 3087 3086 3097 3098 4027 4026
440	5	3058 3059 3088 3087 3098 3099 4028 4027
441	5	3059 3060 3089 3088 3099 3100 4029 4028
442	5	3060 3051 3080 3089 3100 3091 4020 4029