

Copyright Warning & Restrictions

The copyright law of the United States (Title 17, United States Code) governs the making of photocopies or other reproductions of copyrighted material.

Under certain conditions specified in the law, libraries and archives are authorized to furnish a photocopy or other reproduction. One of these specified conditions is that the photocopy or reproduction is not to be “used for any purpose other than private study, scholarship, or research.” If a user makes a request for, or later uses, a photocopy or reproduction for purposes in excess of “fair use” that user may be liable for copyright infringement,

This institution reserves the right to refuse to accept a copying order if, in its judgment, fulfillment of the order would involve violation of copyright law.

Please Note: The author retains the copyright while the New Jersey Institute of Technology reserves the right to distribute this thesis or dissertation

Printing note: If you do not wish to print this page, then select “Pages from: first page # to: last page #” on the print dialog screen

The Van Houten library has removed some of the personal information and all signatures from the approval page and biographical sketches of theses and dissertations in order to protect the identity of NJIT graduates and faculty.

FAULT PROTECTION WITH A DIGITAL COMPUTER

Abstract

A fundamental basis has been developed for the use of a time-shared stored-program digital computer to perform many of the electrical power-system protective-relay functions in a substation. Logic operations are given to detect a fault, locate it and initiate the opening of the appropriate circuit breakers, whether the fault is in the station or on lines radiating from the station.

The instantaneous value of the station voltages and currents are sampled at a 0.5 ms rate, converted to digital form and stored for computer main-frame use. Operating times are compatible with the 25 ms breaker trip capability of modern two-cycle breakers. Computer speed in initiating tripping is a maximum of 4 ms for severe faults and a maximum of 10 ms for moderate or distant faults.

Little attention has been given to hardware or programming aspects; instead this treatment represents the viewpoint of a protective-relay engineer who is attempting to answer the question: can it be done and what is involved? However, major emphasis was placed on minimizing computer main-frame duty.

FAULT PROTECTION WITH A DIGITAL COMPUTER

BY

GEORGE D. ROCKEFELLER, JR.

A THESIS

PRESENTED IN PARTIAL FULFILLMENT OF

THE REQUIREMENTS FOR THE DEGREE

OF

MASTER OF SCIENCE

AT

NEWARK COLLEGE OF ENGINEERING

This thesis is to be used only with due regard to the rights of the author. Bibliographical references may be noted, but passages must not be copied without permission of the College and without credit being given in subsequent written or published work.

Newark, New Jersey

1968

APPROVAL OF THESIS
FAULT PROTECTION WITH A DIGITAL COMPUTER
BY
GEORGE D. ROCKEFELLER, JR.
FOR
DEPARTMENT OF ELECTRICAL ENGINEERING
NEWARK COLLEGE OF ENGINEERING
BY
FACULTY COMMITTEE

APPROVED: _____

NEWARK, NEW JERSEY

JANUARY, 1968

72968

Library
Newark College of Engineering

ACKNOWLEDGEMENT

The author wishes to acknowledge the guidance and assistance of Professor R. E. Anderson of Newark College of Engineering in the preparation of this thesis.

TABLE OF CONTENTS

	PAGE
I. INTRODUCTION	
a. Background.....	1- 5
b. Relaying Philosophy.....	5- 7
II. GENERAL APPROACH	
a. Analog to Digital Conversion.....	8- 9
b. Data Storage.....	9
c. Pre-Fault Routines.....	9-10
d. Executive Structure.....	10-19
III. VFD FAULT DETECTOR	
a. General.....	20
b. Ground Faults.....	20-21
c. Phase Faults.....	21-23
IV. DIFFERENTIAL ZONES	
a. SDF Overall Station Differential.....	24-26
b. BDF Bus Differential.....	26-27
c. TDF Transformer Differential.....	28
d. WS Wave-Shape Analysis.....	28-30
e. CPDSI Differential-Current Peak Routine.....	30
V. DISTANCE LINE PROTECTION	
a. General.....	31-32
b. Voltage Compensation.....	32-33
c. QD Quadrant Determination.....	33

TABLE OF CONTENTS (CONT.)

	PAGE
V. DISTANCE LINE PROTECTION (Cont.)	
d. OPX/OPY Operation Logic.....	33-37
e. Computing Sequence.....	37
f. Time-Delay Trip.....	37
g. Overreaching Transfer Trip (Pilot).....	38
h. Line-Current Peak Change Supervision.....	38-39
i. MA Memory Action.....	39
VI. OTHER PROTECTION	
a. BF Breaker Failure.....	40
b. TOP Turn Off.....	40
c. Routines Not Included.....	40-41
VII. CONCLUSIONS.....	42-44
VIII. RECOMMENDATIONS.....	45
APPENDIXES	
A Definitions.....	46-49
B VFD Speed/Sensitivity.....	50-55
C Time to Current-Transformer Saturation.....	56
D Inductive-Drop Errors Using First Difference.....	57-58
E Distance-Routine Calculations.....	59-65
F Conversion of the Ground-Distance Magnitude Comparison to Angle Comparison.....	66-69
G Distance-Routine Example.....	70-80

TABLE OF CONTENTS (CONT.)

	PAGE
APPENDIXES (Cont.)	
H FIL Voltage Filtering for Distance Routines.....	81- 85
I CPD Line-Current Peak Determination.....	86- 87
J VFD Voltage Fault Detector.....	88- 89
K SDF Station Overall Differential.....	90- 93
L FLOC Line-Fault Locator.....	94- 96
M BDF Bus Differential.....	97- 99
N TDF Transformer Differential.....	100-102
O CPDSI Differential Current Peak Determination.....	103-104
P WS Wave-Shape Analysis.....	105-106
Q Z3G and Z3PH Zone 3 Distance.....	107-111
R Z1 Zone 1 Distance.....	112-113
S Z2T Zone 2 Time-Delay Trip.....	114-115
T Z3T Zone 3 Time-Delay Trip.....	116
U MA Memory Action.....	117-118
V ORTT Overreaching Transfer Trip.....	119-121
W OBK Open-Breaker Keying.....	122-123

LIST OF FIGURES

NO.	TITLE	PAGE
1	Representative Transmission Substation.....	3- 4
2	Pre-Fault Routines.....	11
3	Priority Structure of Key Routines.....	16
4	Zoned Distance Protection at Station P.....	19
5	Effect of Fault Incidence Angle Upon $3V_0$	22
6	An Apparent Voltage Peak May Occur at Sample 0.....	22
7	Percentage Differential Characteristic (PDFC).....	27
8	Some Differential-Current Wave Forms.....	29
9	Distance-Relay Operate Zones.....	35
10	Some Quadrant Positions.....	36
11	An Apparent Peak Will Be Detected If The Drop Exceeds 0.19 Per Unit.....	52
12	Voltage Conditions For BC Faults.....	54
13	Error in Using First Difference of Sinusoid.....	58
14	Angular Relations of $(X + Y)$ and $(X - Y)$	67
15	Phase A to Ground Fault Example.....	71
16	Input Quantities.....	72
17	Z3GS Phasor Relations at Sample 2.....	78
18	Effect of Filtering.....	83
19	CPD Flow Diagram.....	87
20	VFD Flow Diagram.....	89
21	SDF Flow Diagram.....	91
22	Unfavorable Sampling Positions For First Difference.....	92
23	FLOC Flow Diagram.....	95

LIST OF FIGURES (CONT.)

NO.	TITLE	PAGE
24	BDF Flow Diagram.....	98
25	TDF Flow Diagram.....	101
26	CPDSI Flow Diagram.....	104
27	WS Flow Diagram.....	106
28	Z3G Flow Diagram.....	108
29	Z3PH Flow Diagram.....	109
30	Z1 Flow Diagram.....	113
31	Z2T Flow Diagram.....	115
32	MA Flow Diagram.....	118
33	ORTT Flow Diagram.....	121
34	OBK Flow Diagram.....	123

LIST OF TABLES

NO.	TITLE	PAGE
I	ROUTINE LISTING.....	12-13
II	EXECUTIVE PRIORITIES.....	14
III	QUADRANT DETERMINATION.....	33
IV	FAULT EXAMPLE - Z3GS.....	74-76
V	FAULT EXAMPLE - Z1GS.....	80
VI	FILTERING ROUTINE FOR FIG. 18.....	84

I. INTRODUCTION

a. Background

Digital computers are beginning to usurp the functions in the power-system substation now performed by analog and wired-logic circuitry. Installations in service¹ provide data acquisition and monitoring, including sequence of events recording. With most of the needed information already in the computer, control of regulators, breakers, switches, shunt capacitors and reactors, cooling pumps, and transformers seems the natural next step. Later, the computer should assume the protective-relaying and automatic-oscillograph roles to the point where the control house becomes the computer room, physically and conceptually.

What is involved to provide a computer which will sense and locate short circuits and grounds in substation apparatus and connections, or on the lines radiating from the station? More particularly what should the input quantities and the computer speed and storage capabilities be? How about reliability and economics? The treatment here attempts to form the basis for answering these questions by interpreting the protection problems in terms which both protection and computer-oriented people can readily understand. Digital logic is developed to match or substitute for the functions of analog-sensing relays. This logic is then integrated into a time-sharing structure.

1. Pacific Gas & Elec. Co.

Fig. 1 shows a sample transmission substation, involving 500kv, 230kv and 66kv levels. The protective zones bounded by current-transformer and circuit-breaker locations include apparatus, buses and transmission lines. Dotted lines define some of these. For example, a bus 3 fault should be cleared from the system by opening breakers 14 to 18. Current-actuated logic protects the buses, transformers, shunt capacitors and shunt reactors. The line zones also require potential, taken from the line-side coupling-capacitor potential devices at 500kv and 230kv, and from bus 3 potential transformers for the 66kv lines. Series capacitor CPl is protected by the line logic and by overvoltage circuits on the high-voltage capacitor platforms.

Increasing relay equipment complexity and cost for this protection job reflects the ever-present pressure for improved reliability and speed. Moreover, higher power-system voltages which introduce additional relaying problems lend further impetus to the trend toward increasing circuit sophistication and complexity. Except for the almost infinitesimal period during a fault these devices serve no useful purpose and are largely idle, always leaving some doubt as to whether they are capable of operating.

Contrast the relaying trends with those in the digital computer field where the hardware cost for a given level of capability has been dropping and where software sophistication and know-how have been advancing. Consider also that most of the computer circuitry is in frequent, if not continuous use: further, diagnostic routines increase the confidence level in the serviceability of the equipment.

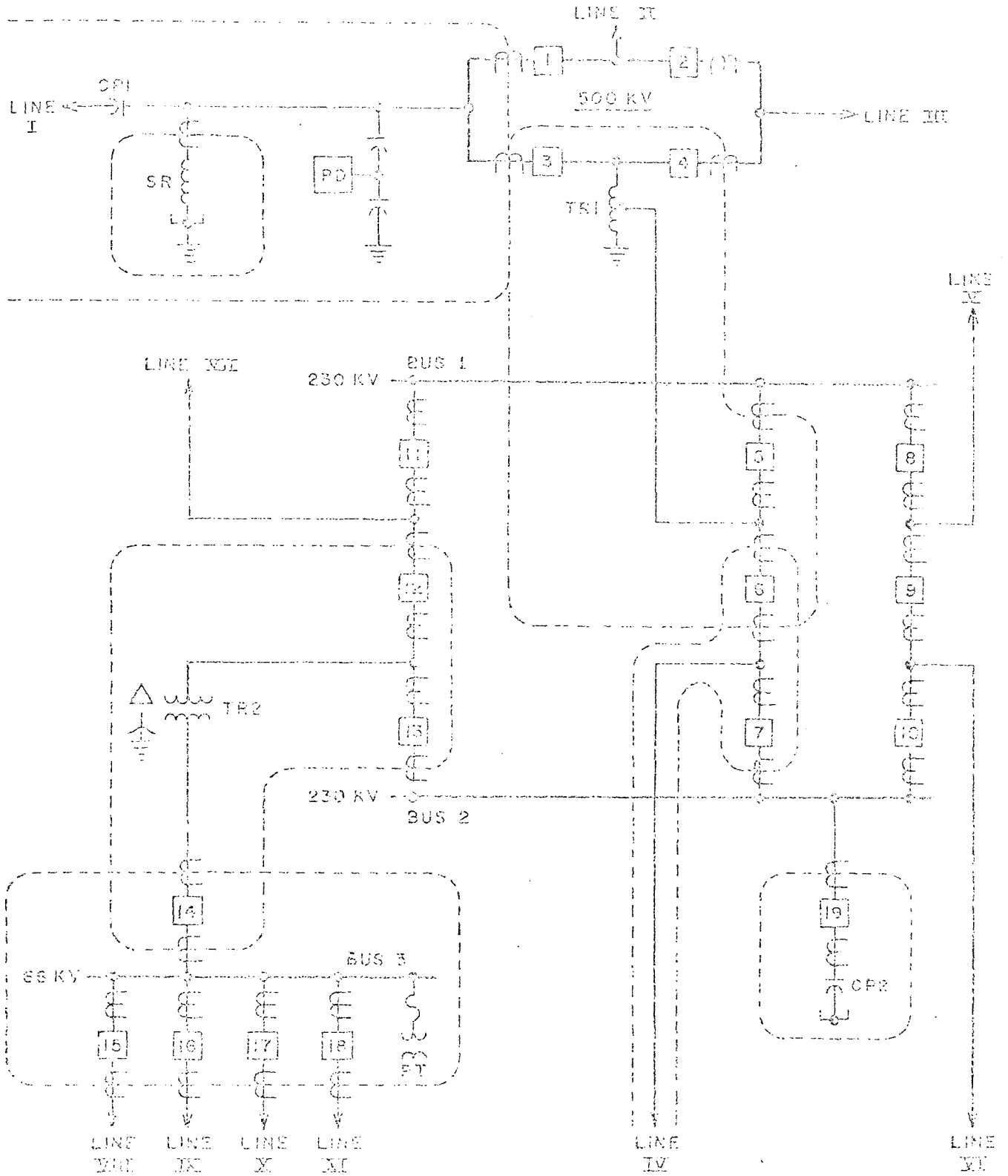
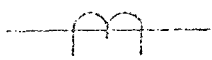

FIG. 1. REFINED NETWORK AND POSITION OF STATION (SITE LOCATION ON NEXT PAGE)



POWER CIRCUIT BREAKER



CURRENT TRANSFORMER OR TRANSDUCER

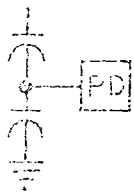

COUPLING CAPACITOR POTENTIAL DEVICE

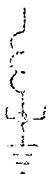

SHUNT REACTOR

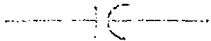

CAPACITOR

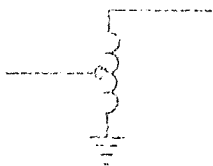

AUTO TRANSFORMER

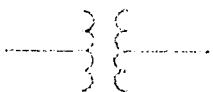

TWO-WINDING TRANSFORMER

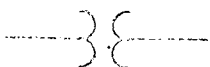

POTENTIAL TRANSFORMER

LEGEND FOR FIG. 1

Most any analog function can be duplicated digitally, including a radio receiver²: Digital filtering of signals is commonplace³. So in spite of the tremendous software job, as well as other seen and unforeseen problems, the time-shared, real-time, stored-program digital computer will someday perform the substation protection function as well as control and data acquisition. What, then, is the nature of the problem?

b. Relaying Philosophy

Faults must be cleared fast and selectively. To avoid generator instability which could readily lead to a widespread blackout, a 3-phase short circuit near a modern generating station must be isolated from the healthy parts of the system in about 0.15s. In this interval the relays must energize the trip coil of the circuit breaker, wait about 0.07s to see if the appropriate breakers open, and then trip other breakers if one of the proper ones fails to interrupt the fault current. Of course, whether a stability problem exists in a given application, the objective is to clear fast, minimizing damage and disturbance to loads.

Fast clearing, per se, is quite easy: the problem is to do it selectively. A surgeon who excises the heart during an appendectomy loses the patient and gets sued for malpractice. So it is with the protection engineer if service interruptions result from opening

2. REF. 11

3. REF. 1

an excessive number of breakers to clear a fault. Many relays sense a given fault, but only those protecting the faulted zone should initiate circuit breaker opening.

While a multitude of highly specialized and sophisticated relays have evolved, for our purposes we need only at this point categorize their underlying principles. To sense a fault (or perhaps locate it), all electrical relays use one or more of the following:

1. Level detection--abnormally high current, low frequency, voltage, for example.
2. Magnitude comparison--The magnitude of voltage compared to line current provides a basis for distance measurement, i.e. how far away the fault is located; or a percentage differential relay compares two currents.
3. Angle comparison--a current falling within a 180° band in relation to a reference voltage may be used to indicate direction of fault power flow. The movement of a center-zero wattmeter needle to the left or right, for example, indicates the direction of real power flow.

Various devices and techniques supplement the basic sensing circuits to improve selectivity and security: filters attenuate off-normal frequencies or select a particular harmonic; operation may be blocked if the period of an ac quantity is too short, indicating a predominance of high frequencies; time-delay and digital logic circuits abound; two widely used means for restricting the operating

zone are one, measurement of the direction of fault-power flow and two, the differential principle, where conditions at the connections leaving a protective zone are compared to locate the fault inside or outside that zone (e.g. summation of currents entering and leaving a bus).

A survey of the above techniques shows only one which computers do not now broadly perform to the author's knowledge: viz. angle comparison. Accordingly, much time is devoted later to this area, although the requirement for 4 ms (0.25 cycles) tripping of severe faults rules out many of the more obvious approaches to programming the other areas. As will become apparent, time (or rather the lack of it) represents the paramount problem.

II. GENERAL APPROACH

a. Analog to Digital Conversion

For the station in Fig. 1 the computer (or peripheral gear) must convert to digital form the instantaneous value of 129 ac quantities (35 sets of currents, 8 sets of voltages). Each is sampled every 0.5 ms. With such a fast rate the station control cabling must be well shielded to minimize both magnetic and capacitive coupling. However, this does not relieve the program completely from avoiding tripping should a surge introduce a substantial error into a sample.

Rated phase to ground voltage is 69V rms, rated current is 5A rms. Accurate distance measurement by the program should occur down to 5V peak; two successive voltage samples, then, could be less than 0.5V when the wave is crossing zero. A-D conversion error should not exceed 3% of the correct value (not full scale) over the range of 0.5-100V, instantaneous. Similarly, the current conversion error should not exceed:

3%	0.5-100A, instantaneous
10%	0.2-250A, instantaneous

Certain readings will be part of the same computation so care must be exercised as to the order in which all these quantities are sampled. Otherwise the program must take the time to correct for the non-simultaneity of related readings.

The objective of 4ms tripping of severe faults fixes the sampling interval of 0.5 ms. A minimum of six post-fault samples are needed to

trip a transmission line fault, so the maximum speed is about 3 ms for this zone.

b. Data Storage

Storage requirements include:

1. 10 samples of all phase currents and the phase to ground voltages on each kv level (3450 currents and 270 voltages in Fig. 1).
2. 2 peak magnitudes of the above quantities (754).
3. Sample number (i.e. time position) of the current peaks (690).
4. 2 peak magnitudes of line to line voltages (36).
5. 33 samples of quadrant position for VAB on each kv level (99).
6. 2 peak magnitudes and sample number of differential currents (60).

There are a total of 5359 words of storage required for the application in Fig. 1 for the above enumerated purposes. While this does not include program statements nor most of the computational storage needs, it would appear that memory requirements are moderate unless speed dictates that flip-flops be used for a substantial part of the storage.

c. Pre-Fault Routines

Fig. 2 visualizes that peripheral gear performs the analog to digital conversion (AD), providing an interrupt to the executive program

EX at the appropriate times so it can call the other routines shown here. Table I lists these routines, indicating where they are described. Routines MA, CPD and VFD are called at 0.5 ms intervals (i.e. after each sample), while TDF is called every 32 ms. VFD looks for an aberration in the voltages, indicating the possibility of a fault. Since a low-current fault in station apparatus may not produce a detectable effect on voltage, TDF periodically looks for such a condition by checking each transformer zone. VFD calls more sophisticated logic to locate the fault. Before discussing any of these routines in detail the overall organization will be presented.

d. Executive Structure

Table II lists routine priorities with the lowest numbered priority taking precedence of all those routines for which bids have been entered. A minority have variable priorities as a function of events enumerated horizontally at the top of the table. Until more is said about the various routines this tabulation will have little significance. Suffice it to say the prime objective of this structure is to detect and locate faults as rapidly as possible; the secondary objective is to efficiently utilize any spare time during faults looking for another zone that might be faulted. If breaker 2 in Fig. 1 becomes faulted both line II and III zones may see a fault and both breakers 1 and 4 may have to open to clear this fault. Also, while not the usual case, separate simultaneous faults may occur, such as on both double-circuit lines due to lightning or due to an airplane collision. So the program cannot relax once it has located a fault.

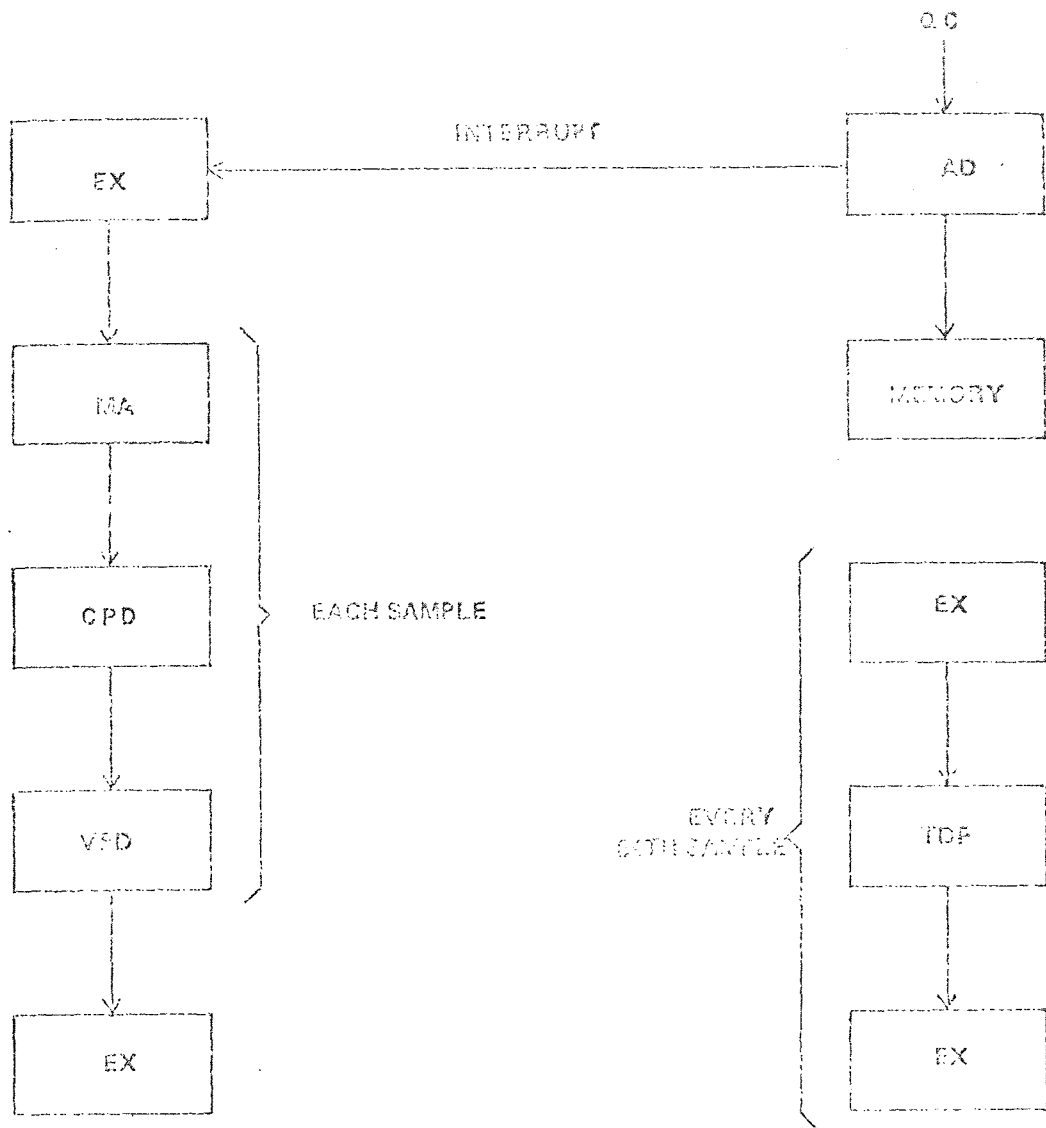

FIG. 2 PRE-FAULT ROUTINES

TABLE IROUTINE LISTINGS

<u>DESIG-</u> <u>NATION</u>	<u>DESCRIBED</u> <u>SECTION</u>	<u>IN:</u> <u>APP.</u>	<u>DESCRIPTION</u>
AD	II	--	Analog-to-digital conversion of instantaneous value of a-c voltages and currents
BDF	IV	M	Bus differential
BF	VI	--	Breaker failure
CPD	--	I	Line-current peak determination
CPDSI	IV	O	Differential-current peak determination
EX	II	--	Executive
FIL	--	H	Voltage filtering
FLOC	--	L	Line-fault locator
MA	V	U	Memory action for Z3PH
OBK	--	W	Open-breaker keying
OPX	V	--	Operation logic (90-270°)
OPY	V	--	Operation logic (0-180°)
ORTT	V	V	Overreaching transfer trip
PDFC	FIG. 7	--	Current comparison
QD	V	--	Quadrant determination
SDF	IV	K	Station overall differential

TABLE I - CONT.

<u>DESIG-</u> <u>NATION</u>	<u>DESCRIBED</u> <u>SECTION</u>	<u>IN:</u> <u>APP.</u>	<u>DESCRIPTION</u>
TOP	VI	--	Turn off of fault programs
TDF	IV	N	Transformer differential
TRIP	--	--	Breaker tripping
VFD	III	B,J	Voltage fault detector
WS	IV	P	Wave-shape analysis
Z1	--	R	Zone 1 distance logic, phase and ground
Z1GS	--	E,G	Zone 1 ground-distance calculations
Z1PHS	--	E	Zone 1 phase-distance calculations
Z2GS	--	E	Zone 2 ground-distance calculations
Z2PHS	--	E	Zone 2 phase-distance calculations
Z2T	--	S	Zone 2 time-delay trip
Z3G	--	Q	Zone 3 ground-distance logic
Z3PH	--	Q	Zone 3 phase-distance logic
Z3GS	--	E,G	Zone 3 ground-distance calculations
Z3PHS	--	E	Zone 3 phase-distance calculations
Z3T	--	T	Zone 3 time-delay trip

TABLE II EXECUTIVE PRIORITIES

ROUTINES	PRE- FAULT	UPON VFD OPER.	UPON SDF OPER.	PDF CTR. > 0	UPON FLOC OPER.	Z3G/PH CTR. > 0	NO FAULT FOUND	UPON TRIP	UPON TRIP	BID ENTERED BY:
TRIP	1									
MA	2									(C)
VFD	2	NONE							2	(C)
CPDIL	2									(C)
CPDSI	2									VFD
ZI (#) (b)	3							BR		Z3G/PH CTR. > 0
ORTT (#)	3									Z3G/PH
Z2T (#)	3							BR	3	Z3G/PH (#)
Z3T (#)	3							BR	3	Z2T (#)
OBK	3									INTERRUPT
TOP	4									
SDF	5		NONE						5	VFD
BF (a)	5									TRIP
CPC (#)	5									Z3PH & CPDIL
FLOC	6									VFD
WS	6									BDF/TDF & CPDSI
Z3G/PH	8									VFD
Z3G/PH (#)	8				5	3	10	BR	8	FLOC OR Z3 CTR.
Z3G/PH (Ø)	8				7				8	
BDF	9			5					9	VFD
TDF	9			5					9	VFD OR EX
NON-FAULT	11									
BDF/TDF (#)	SA			3			9	BR	SA	

NOTES

(a) PARTICULAR BREAKERS, RELATED TO FAULTED ZONE
(e, g, BKRS, 2 & 4 LINE III)(SA) SAME PRIORITY AS BDF/TDF
(I, e, 9 OR 5)

(b) BID REMOVED AFTER 32 UNSUCCESSFUL PASSES

(#) PARTICULAR ZONE
(e, g, LINE III OR BUS 1)

(c) CALLED EACH SAMPLE

(Ø) PARTICULAR VOLTAGE LEVEL
(e, g, 230KV)

(BR) BID REMOVED

Fig. 3 depicts the priority and bid movement of key routines when VFD thinks it sees a fault. Priority numbers are shown in parenthesis. VFD (block A) may detect a voltage aberration due to switching rather than a fault. So it enters a bid for TOP (J); after 16 ms delay a bid is entered for turn off of the fault program with a priority of 4. If the locator routines (BDF/TDF and Z3) show any indication of a fault at least one routine will have a priority 3 or better to block turn off.

VFD(A) in Fig. 3 enters bids for SDF, FLOC, Z3G/PH and BDF/TDF per block B. VFD loses its priority until the fault program turns off. SDF with the predominant priority sums the currents of all lines entering the station. However, if SDF becomes suspended awaiting the next sample, FLOC is given a chance to find the line most likely to be faulted. If FLOC "locates" a fault before SDF, block K answers yes. Instead with a fault in the station if SDF operates first, block C answers yes. Then (in block F) the bus zones BDF and transformer zones TDF have their priority advanced from 9 to 5, taking precedence over the line zones Z3G/PH, since SDF has indicated that a fault is somewhere in the station. BDF/TDF are called in an arbitrary programmed order. Each sums the currents surrounding its zone. For example, in Fig. 1 TR2-TDF sums the per-unit currents in breakers 12, 13 and 14.

For any particular zone, shown as BDF/TDF (#), to initiate breaker tripping there must be two successive passes through that particular routine which indicate a fault. On the first such pass the priority of that zone advances from 5 to 3 (see block F1 in Fig. 3), to take precedence over all other zones. If tripping does occur

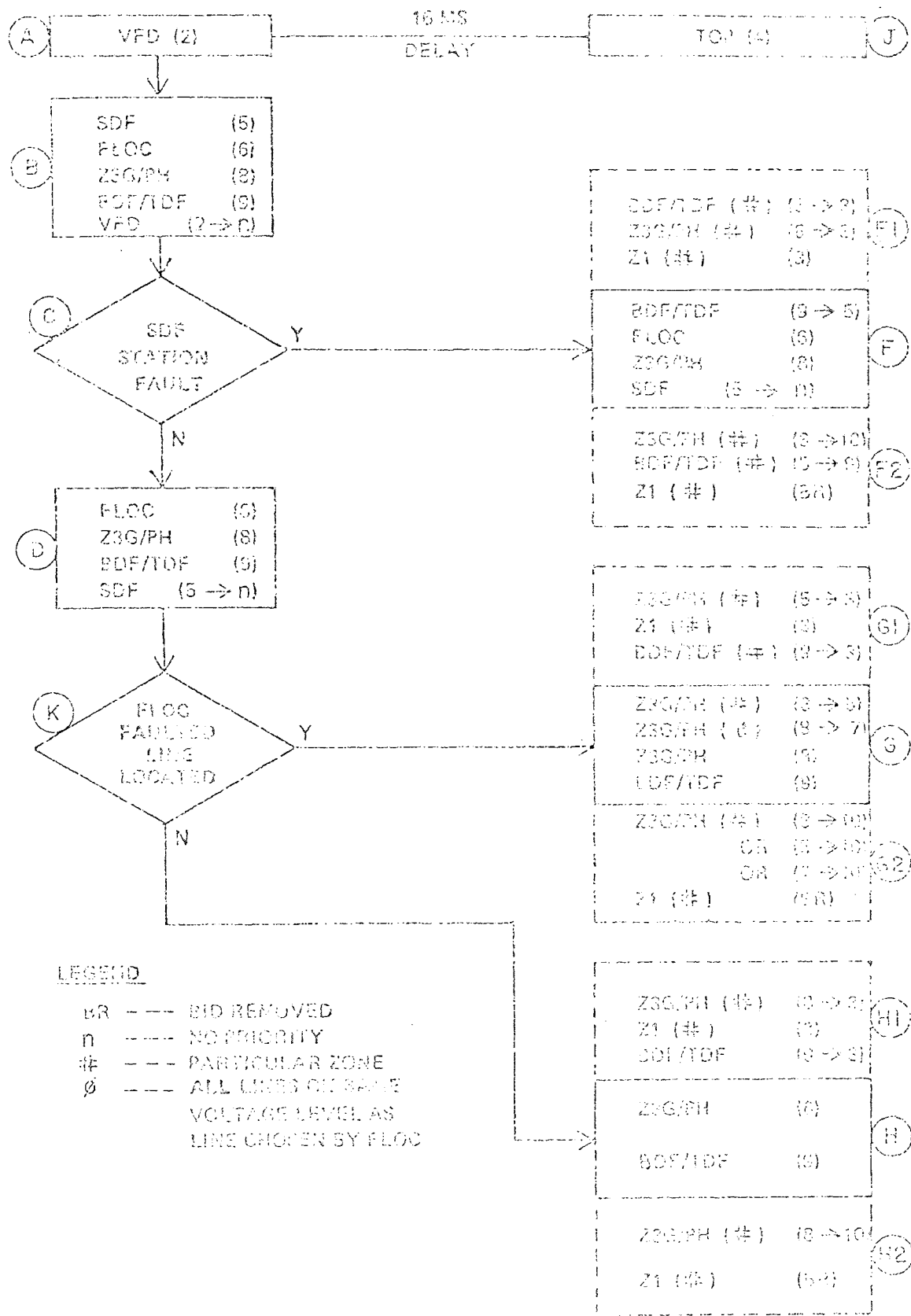

FIG. 3 PRIORITY STRUCTURE OF KEY DC LINES (PRIORITY INDICED IN PARENTHESES)

on the next pass, the bid for this zone is removed. The search for other faults continues.

When time permits, line-fault locator FLOC in block F is called. FLOC tries to pinpoint which line is faulted so it can call a particular Z3. These Z3 routines use line current and potential to look for line faults. Fig. 4 shows that zone 3 at station P senses faults in the entire line section out to station R, and beyond. If Z3G or Z3PH also senses a fault it enters a bid for Z1(#) and advances its own priority to 3, per block F1 of Fig. 3. Zone 1 in Fig. 4 covers only 85-90% of the line to insure that it will not see faults on adjacent lines such as at F2. It can initiate immediate tripping of breakers 1 and 2 with no danger of unnecessary breaker opening. If Z1(#) fails to find a fault its bid is removed (block F2, Fig. 3). As individual Z3 or apparatus zones fail to find a fault, their priority is reduced (F2). However, these zones will still be called if time permits before TOP turns off the fault program and allows non-fault routines to run.

Return now to block C in Fig. 3 where it answers no if SDF fails to find a fault in the station. When this occurs FLOC attempts to find the faulted line. If FLOC gets a positive indication, block K answers yes, advancing the zone 3 priority (G) on both the selected line and all other lines at that kv level. The latter priority change guides the program as to where to look next if FLOC selects the wrong line. As with block F1, particular routines may advance in priority (G1); as with F2, priorities may drop, or be withdrawn (G2).

If FLOC in Fig. 3 fails to select a likely line, block K answers no. Zone 3 routines are called in an arbitrary programmed order (H). As the search progresses priorities may go up (H1) or down (H2), as positive or negative indications of a fault appear in the various zones.

III. VFD FAULT DETECTOR

a. General

Faults cause aberrations in the currents and voltages. At fault inception a sudden rise or drop in voltage can occur. Current and voltage peaks can change in magnitude and/or phase position with respect to prefault conditions. Of course, these aberrations may also result from switching or load changes. Therefore, the fault-detection logic must not be so sensitive that non-fault programs are being interrupted too much for "false alarms."

VFD looks only at one set of voltages for each KV level. It ignores currents to minimize pre-fault duty since there are many more currents than voltages (11 sets of line currents, 3 sets of voltages in Fig. 1). Furthermore, voltages can change magnitude instantaneously, while currents cannot. So the use of voltage offers faster fault detection.

b. Ground Faults

After each sample, VFD first calculates the residual voltage $3V_0$ (see App. A for definition) and the magnitude of its first difference $3V'_0$. If the latter exceeds $1/64$ per unit, detection occurs. For most ground faults detection will occur on sample 0 (i.e. the first sample after fault inception). The voltage changes abruptly per Fig. 5 (a) unless the fault occurs when $3V_0$ is at angle 0° , as shown in Fig. 5(b). With zero initiation there will be sufficient $3V'_0$, provided the $3V_0$ peak exceeds 0.09 pu. As described in App. B, if $3V'_0$ is too

small due to a distant fault, the phase-fault logic (to be discussed below) will detect it.

This logic is performed once per sample for each voltage level.

c. Phase Faults

The phase logic looks for a peak by sensing a change in the sign of the first difference (difference of the present and previous sample value). If V_{AG} , V_{BG} , V_{CG} , V_{AB} , V_{BC} , or V_{CA} is $1/64$ pu less than the previous peak of the same voltage, VFD operates.

An apparent peak may be detected at sample 0 as shown in Fig. 6 (a) where the prefault voltage is in quadrant I or III (i.e. first difference is positive). Here the sign of the first difference changes between sample -1 and 0. That is:

$$(V)_0 - (V)_{-1} \quad \text{is negative}$$

$$(V)_{-1} - (V)_{-2} \quad \text{is positive}$$

Similarly for an unbalanced fault where the fault voltage shifts substantially relative to prefault, a first difference sign change (and hence an apparent peak) can occur as shown in Fig. 6(d) at sample 1. Here the voltage shifts back one quadrant at fault inception.

In the cases of Fig. 6(b) & (c), detection must await the next actual peak, since no first-difference sign change occurs at sample 0 or 1 as compared to sample -1. Frequently, this does not require a long wait to detect the fault, since VFD looks at six voltages.

App. B analyzes the detection time with the following conclusions:

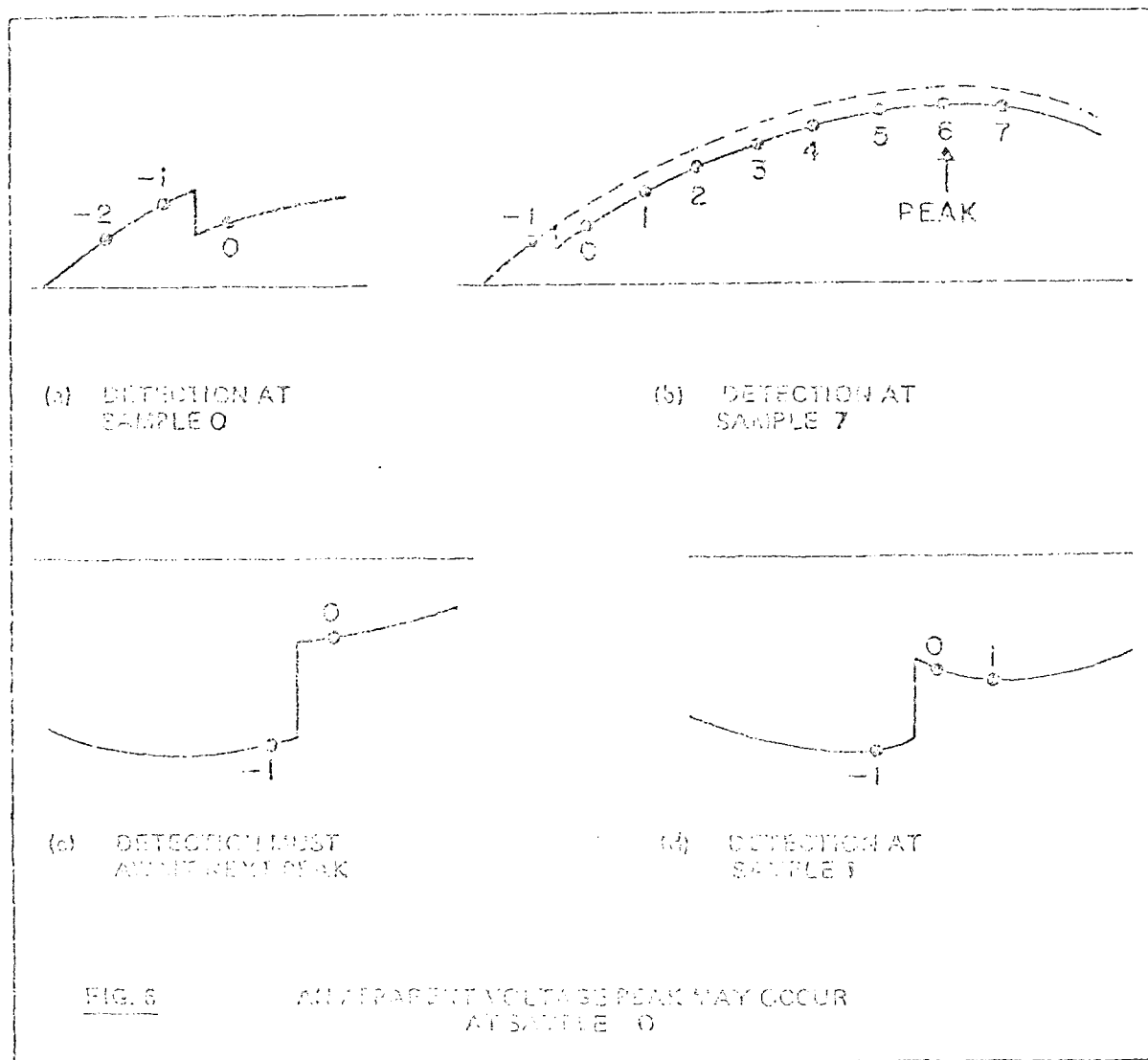
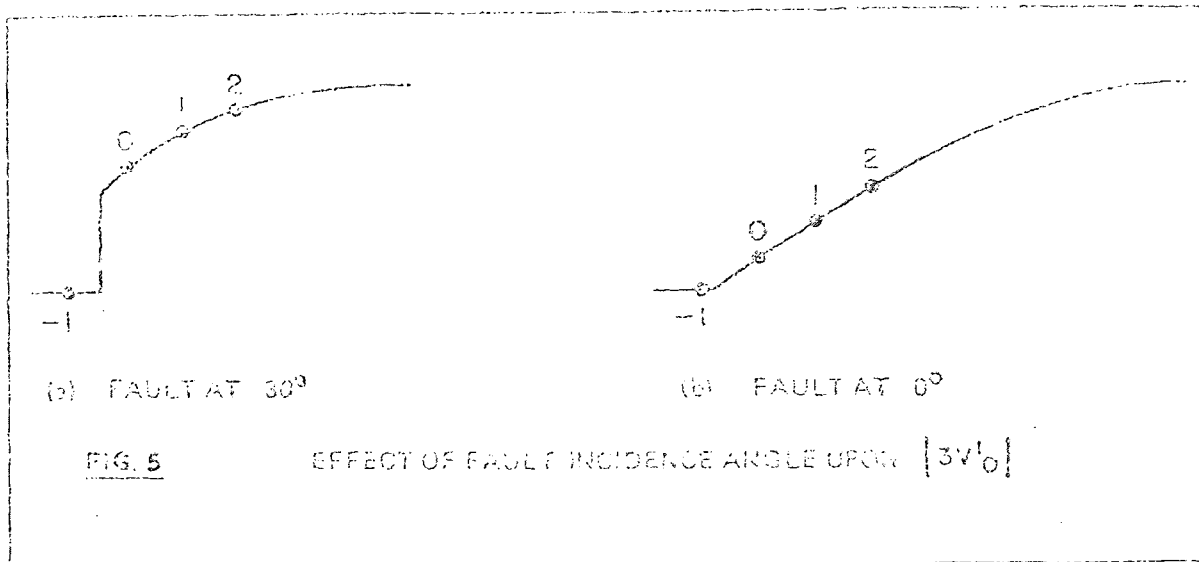

		<u>Detection Sample</u>
three-phase fault	10% minimum voltage	0
	collapse less than	
	10%	0-3
phase-phase or		
two-phase-ground	near fault	0-2
	distant fault	0-11

A two phase-to-ground fault may also be detected at sample 0 by the ground logic. Of course, distant phase-phase faults may not be cleared within 4 ms; however, these are not severe enough to require this fast an operation. Likewise a distant single-phase-to-ground fault may not operate the ground logic, so the phase logic may not detect the fault until sample 17 if only the faulted phase to ground voltage collapses by a detectable amount.

It can be seen, then, that VFD detects all nearby (and hence severe) faults by sample 3, allowing time for the locator programs SDF and Z3/Z1 to set up tripping by sample 7 (i.e. 4 ms after fault). Note that the locator programs start at sample 0 rather than the latest sample (assuming the present sample is 9 or less). This minimizes the possibility of waiting for more samples to complete the necessary number of passes.

IV. DIFFERENTIAL ZONES

a. SDF Overall Station Differential

When called by VFD fault detector, SDF serves to narrow the search for the fault location. If a bus or transformer becomes faulted, SDF can sense that the fault is within the station to give BDF/TDF higher priority than the Z3 line routines. The differential routines can trip at sample 1, while the lines cannot be tripped until sample 5. For this reason VFD calls SDF rather than FLOC. However, if time is available EX calls FLOC, while SDF waits for another sample.

After summing the phase A line currents for the entire station, SDF checks to see if the first difference of this differential current exceeds 0.05 pu in magnitude. This check allows for a 60 Hz differential current of about 0.25 pu peak without operating. Without this check, power transformer steady-state exciting current could cause false indication. While rated exciting current ranges from 1-2% of rated transformer current, a rise in the sound phase voltage during a fault can produce a substantial exciting current increase.

The first difference check could be unsuccessful for samples 0 and 1 for any level of steady-state peak, if the fault occurs near a steady-state peak; accordingly SDF will process four samples, if necessary. Then, SDF removes its own bid. As derived in App. K, for the most unfavorable inception angle the differential current must exceed 1.4 pu steady-state peak for SDF detection. More moderate faults will be detected when EX makes its periodic TDF call. Should VFD sometimes

be more sensitive than SDF for a station fault, BDF/TDF will be called after FLOC and Z3 fail in their search to find the fault. The resulting delay in this case is tolerable due to the low current level.

By limiting the SDF check to the first four samples, current-transformer saturation will be negligible¹. PDFC (Fig. 7) also contributes to security against false operation by requiring the differential current to be proportionately larger as the fault-current level rises. The summation of the magnitudes of the line currents form the abscissa. As this sum increases so will the false differential current due to mismatch of the current transformer ratios on different sides of power transformers. During operation the transformer voltage taps vary to regulate voltage by as much as $\pm 15\%$ of nominal ratio, as represented by the 15% mismatch line.

At point M in Fig. 7 the operating-line slope increases to accommodate errors resulting from current-transformer saturation. Since SDF stops at sample 3 this added security measure is not required; however, BDF and TDF, which also use PDFC, do function during saturation.

With all lines feeding in-phase current to a station fault, the differential current magnitude (ordinate) equals the summation of the magnitudes (abscissa); Fig. 7 shows this limit for the operating zone (line O-L). Particularly for faults of load-current level, the various line currents will be out of phase, so the operating point can be below line O-L.

1. App. C

If the phase A check fails to find a fault, phase B and, if needed, phase C conditions are computed.

b. BDF Bus Differential

As with SDF, BDF looks for a differential-current first difference of at least 0.05 pu. In this case the differential current is the summation of the currents connecting to the bus. After sample 3 if BDF (#) thinks it sees a fault, BDF (#) of that particular phase suspends itself and enters a bid for WS wave-shape analysis, which checks for severe CT saturation. WS also becomes suspended until CPDSI detects a peak in the associated current since WS examines the magnitude and position of the peaks. If WS finds a satisfactory wave form, it removes the BDF (#) suspension, to allow additional passes.

After a successful WS the differential current will be near peak, where the first difference will be a minimum. Therefore, BDF can bypass the first difference check if the magnitude of the differential current exceeds 0.025 pu. If the magnitude or the first difference exceeds the setting, PDFC (Fig. 7) is called. Two successive positive passes cause tripping of all the bus breakers.

Ordinarily, BDF would not require WS since it needs only two of the first four samples to trip. However, if a bus fault occurs subsequent to a VFD operation where samples 0 to 3 have cleared the buffer storage, a WS call allows for delayed tripping. Low-current faults may also delay BDF beyond sample 3, where the first difference may not exceed 0.05 pu.

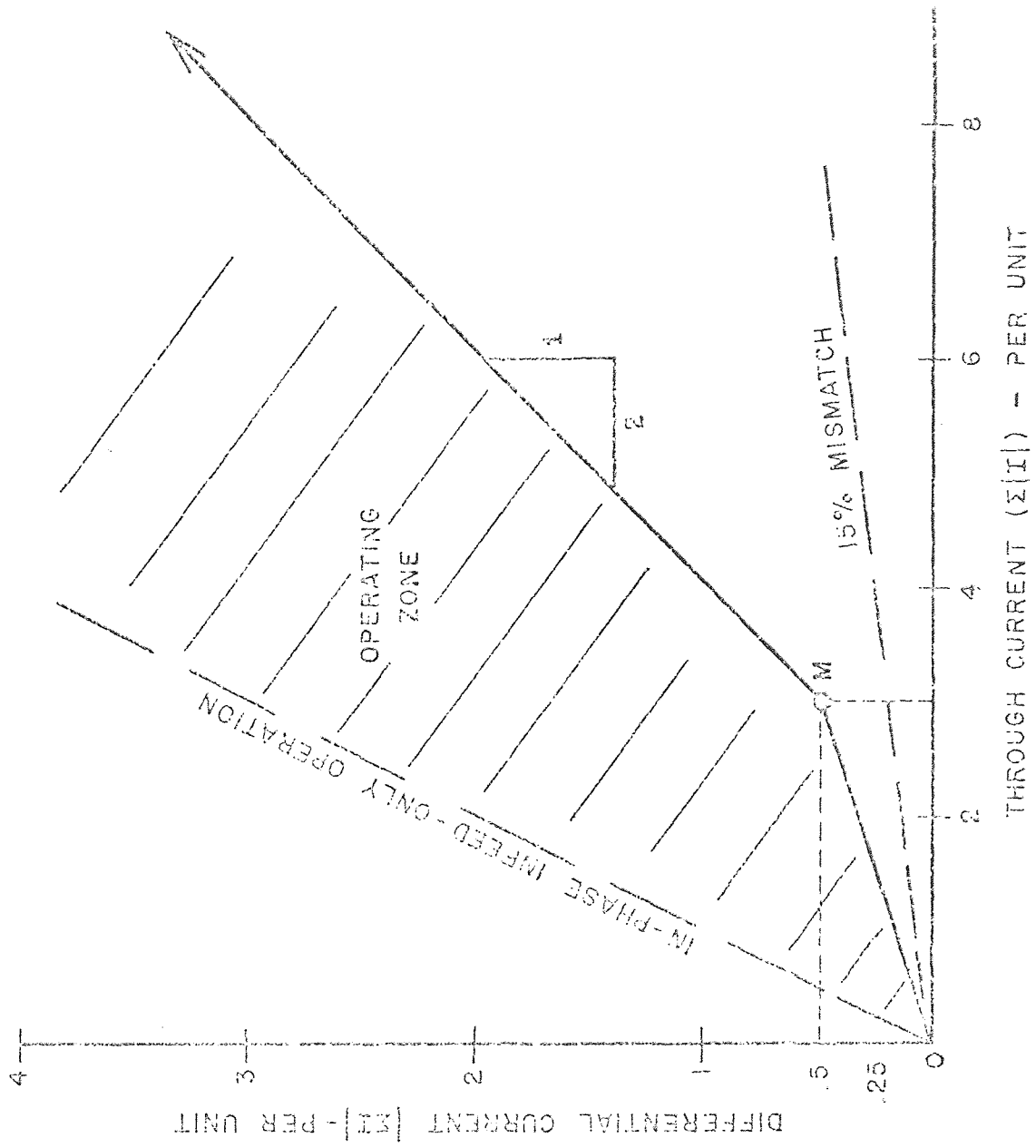

FIG. 7 PERCENT DIFFERENTIAL CHARACTERISTIC (PDFC)

c. TDF Transformer Differential

As with BDF, a WS wave-shape analysis can be bypassed on the first four samples after VFD senses a fault (i.e. before dc CT saturation can occur). However, when EX periodically calls TDF, WS will not be bypassed. Also with TDF, the possibility of magnetizing inrush requires an additional security restriction: do not bypass WS on the first four samples if any switching has occurred in the last 32 ms. Otherwise if VFD operates due to a transformer energization, magnetizing-inrush current could cause TDF to trip off those transformer breakers. With these exceptions the TDF logic is the same as BDF.

d. WS Wave-Shape Analysis

Substantial differential current may result from either magnetizing inrush² (such as in Fig. 8(a) or (b)) or from dc CT saturation³ (such as in Fig. 8(c) during external faults.) Successive peaks of either inrush current in Fig. 8 fail to occur at about 8 ms intervals. In Fig. 8(a) the peaks are too far apart; in (b) the opposite is true. To distinguish between inrush and legitimate fault currents, WS requires 15 to 20 samples between peaks, or 7.5 to 10 ms.

The current in Fig. 8(c) meets the requirement of 15 to 20 samples between peaks during the first four cycles (if we define point P as a peak). Accordingly, WS also imposes the requirement that a

2. Ref. 3 and 8

3. Fig. 6A and 7 of Ref. 10

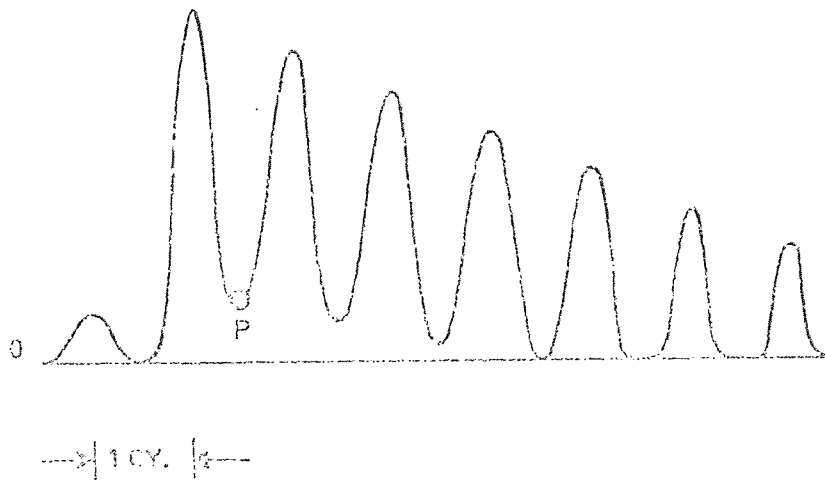
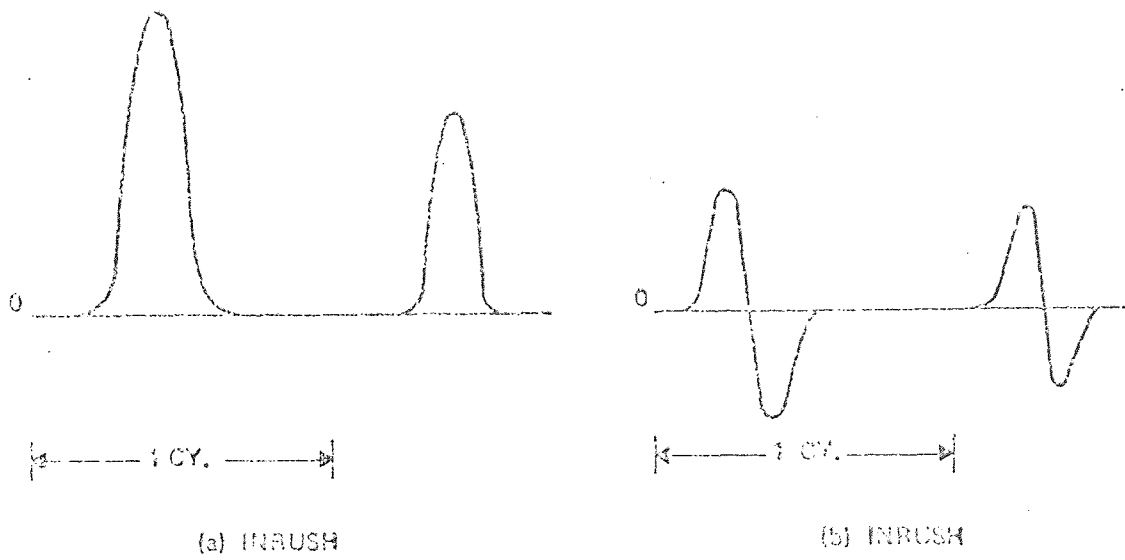

(c) D-C SATURATION OF CURRENT TRANSFORMER DURING EXTERNAL FAULT

FIG. 3 SOME DIFFERENT CURRENT WAVE FORMS

peak be 75 to 125% of the previous peak and, for good measure, of opposite sign. WS then calls BDF(#) or TDF(#) if the peak requirements are met.

When BDF or TDF bids for WS, the bid is suspended until CPDSI detects a differential-current peak.

e. CPDSI Differential-Current Peak Routine

VFD enters a bid for CPDSI. This routine computes the three differential currents and their first difference for each bus and transformer zone each sample. When it detects a sign change in the first difference, the differential current value is defined as a peak. If the sum of this peak magnitude and the previous peak magnitude exceeds 32 pu and if the two peaks are at least 15 samples apart, CPDSI initiates tripping. Otherwise, if the associated WS suspended bid has been entered, the suspension of the particular phase of that particular differential zone is removed.

Note, from the above, that CPDSI can bypass the differential and wave-shape routines to trip on the first peak for a fault exceeding 32 pu, assuming the CT (current transformer) does not saturate prior to this point. For a 16 pu current, CPDSI can trip on the second peak, again with good CT performance. This logic minimizes trip delays for severe faults due to WS calls. This feature is particularly important with the transformer zones when energizing a faulty power transformer. In this case TDF cannot trip without a WS call due to the likelihood of TDF operation due to magnetizing inrush. With a slowly decaying dc current transient, WS could delay TDF tripping for several cycles.

V. DISTANCE LINE PROTECTION

a. General

Fig. 4 shows the distance routine coverage. Zone 1 reaches 85 to 90% from station P towards station R, tripping with no intentional time delay. Zone 2 reaches beyond station R to insure detection of an end-zone fault such as at F1. Since zone 2 also unavoidably sees adjacent-line faults such as F2, its tripping must be delayed by time T2 to allow breaker 4 relaying to clear F2. Zone 3 reaches still further to:

1. Initiate T3 delayed back-up tripping of adjacent-line faults should the primary relaying fail.
2. Assist in locating which line is faulted.
3. Provide instantaneous tripping of end-zone faults, working in a pilot scheme, in conjunction with the breaker 3 zone 3 and a transfer-trip channel.

All three zones are directional, operating only for faults in the protected line or beyond station R.

These routines use the compensated voltage principle¹ where the protected-line currents modify the station voltages. Five angle comparisons are made: three for single-phase-to-ground faults (one per phase), phase-to-phase unit for two phase faults and 3 phase unit for 3 phase faults. In the analog relays, compensators, energized on their

1. Ref. 6 and 7

primary with the line current, induce a secondary voltage which is a replica of the actual transmission-line impedance drop from the relay to a preset balance point. For example, the phase-to-phase unit of the phase distance relay develops a compensated phasor voltage \dot{V}_{ZY} :

$$\dot{V}_{ZY} = \dot{V}_{CB} - (\dot{I}_C - \dot{I}_A) Z_C \quad (1)$$

where Z_C = the positive-sequence line impedance from the desired balance point (e.g. 90% of the line for the zone 1 relay)

Another compensator similarly modifies \dot{V}_{AB} to yield \dot{V}_{XY} . If \dot{V}_{XY} leads \dot{V}_{ZY} by 0 to 180° the relay trips. The routine, then, must develop these compensated voltages and make a phase angle comparison.

b. Voltage Compensation

Eq. (1) can be written for a zone 1 reach in instantaneous values as: $V_{ZY1} = (V_{CG} - V_{BG}) - L_1 \frac{d(I_C - I_B)}{dt} - R_1(I_C - I_B)$ (2)

A sampled-data approximation for sample K is:

$$V_{ZY1} = (V_{CG})_K - (V_{BG})_K - \frac{L_1}{h} \left[(I_C)_K - (I_C)_{K-1} + (I_B)_{K-1} - (I_B)_K \right] - R_1 \left[(I_C)_K - (I_B)_K \right] \quad (3)$$

Actually this approximation for the inductive drop introduces excessive error as analyzed in App. D, so an average of the first difference is computed. When the current is in quadrants I and III, the K and K + 1 differences are averaged; in Quadrants II and IV, K and K-1 are averaged. While this averaging consumes more computer time and

delays tripping by one sample, it reduces the reach error to less than 1% as compared to the much larger error in Fig. 13. Of course, an increase in the sampling rate reduces this error but not as effectively as averaging.

c. QD Quadrant Determination

In quadrants I and IV the first derivative of the sine function is positive; while the second derivative is negative in quadrant I, positive in IV. Thus, the combination of the sign of the first and second differences defines the quadrant, as specified by Table III.

Table III - Quadrant Determination

	Quadrant			
	<u>I</u>	<u>II</u>	<u>III</u>	<u>IV</u>
First Difference	+	-	-	+
Second Difference	-	-	+	+

d. OPX/OPY Operation Logic

Fig. 9 shows the angular relationship requiring operation. The phase-to-phase unit in section V (a) compares V_{XY1} and V_{ZY1} , with V_{ZY1} corresponding to V_{REF} and V_{XY1} to the operating voltage in Fig. 9(b). When V_{XY1} leads V_{ZY1} by 0 to 180° operation occurs. The three-phase unit and the ground-distance units have the Fig. 9(a) characteristic; in this case either voltage of the pair being compared may be the reference.

Looking at Fig. 9(a) for OPX, note for an operating condition that the two voltages can never occupy the same quadrant as they do in

Fig. 10(a) since they must be more than 90° apart. Conversely, for a non-operate condition, the voltages can never occupy opposite quadrants as they do in Fig. 10(b). They will occupy adjacent quadrants for some samples regardless of their phase positions, as in Fig. 10(c). With an angle near 90° the transitional sample can yield erroneous results due to the finite sampling interval. For example, in Fig. 10(a) near a quadrant change, QD may erroneously indicate opposite quadrants.

These facts suggest this logic:

1. Increment operation counter with voltages in opposite quadrants.
2. Decrement operation counter with voltages in same quadrant.
3. Operate when counter reads 2 or more.
4. Counter range: 0-3

Fig. 9(b) for OPY dictates similar logic to OPX:

1. Increment operation counter with operating voltage in adjacent leading quadrant. (e.g. V_{OP} in I, V_{REF} in IV).
2. Decrement operation counter with operating voltage in adjacent lagging quadrant.
3. Operate when counter reads 2 or more.
4. Counter range: 0-3.

Fastest operation occurs when V_{OP} and V_{REF} are at 180° for OPX, or when V_{OP} leads V_{REF} by 90° for OPY. At these angles the maximum

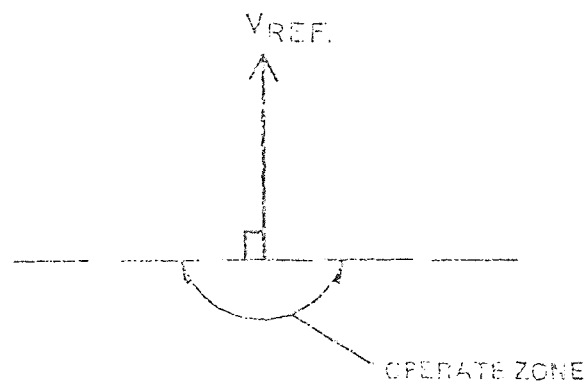

(a) 90-270° ZONE (OPX)

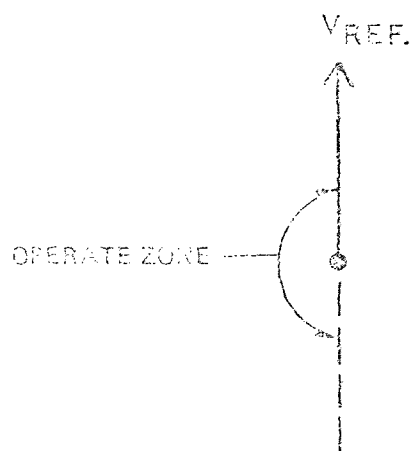

(b) 0-180° ZONE (OPY)

FIG. 9

DISTANCE RELAY OPERATE ZONES SHOWING
SECURED POSITIVE LOG OPERATING VOLTAGE
IN RELATION TO REFERENCE VOLTAGE

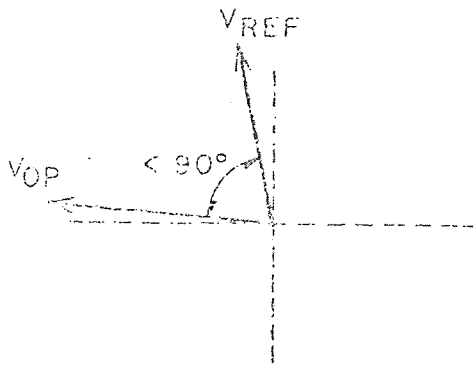

(a) SAME QUADRANT

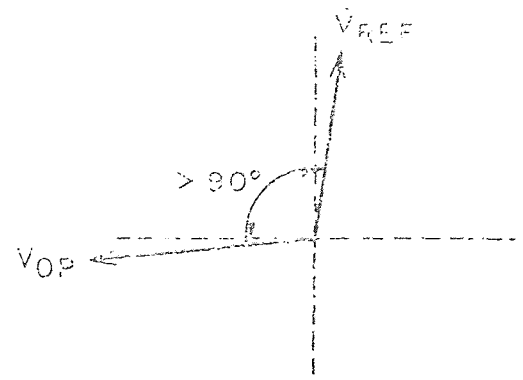

(b) OPPOSITE QUADRANTS

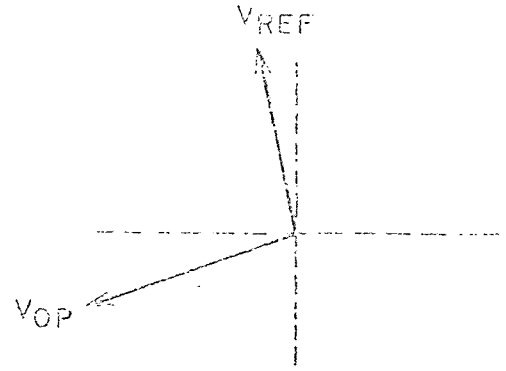

(c) ADJACENT QUADRANTS

FIG. 10. 90-DEGREE VECTOR POSITIONS

number of samples yield counter incrementation. This situation approximately prevails for at least one of the five angle comparisons (three-phase, phase-to-phase, A-to-ground, B-to-ground and C-to-ground logic) for faults with small fault resistance compared to the impedance reach setting (e.g. H_1). Note that each of the five angle comparisons for each zone of each line uses a separate operation counter.

e. Computing Sequence

Zone 3 (Z3G and Z3PH) is called first since it covers a larger area than do zones 1 and 2. When one of its operation counters is first incremented, zone 3 advances the priority of itself and zone 1 (Z1G, Z1PH) of the same line. EX makes no priority distinction between the phase (PH) and ground (G) routines for two reasons: first, some of the computations are common to G and PH, and secondly, Z3PH may operate for a phase-to-ground fault sooner than Z3G, even though Z1PH will not operate, while Z1G will.

f. Time-Delay Trip

When any zone 3 operation counter reaches two it enters a T_2 delayed bid for zone 2 (Z2T). If zone 3 remains operated until T_2 has expired, Z2T is called. After about the first 16 ms of the fault, zone 3 computes only at 16 ms intervals, allowing time for non-fault routines to run. When Z2T is called if Z2GS or Z2PHS fails to operate, Z2T enters a $(T_3 - T_2)$ delayed bid for Z3T. If Z3G or Z3PH continues to operate at 16 ms intervals until $(T_3 - T_2)$ elapses, Z3T trips the line breaker(s).

g. Overreaching Transfer Trip (Pilot)

This logic provides fast clearing of all faults in the immediate line section (between stations P and R in Fig. 4), if the transfer-trip channel is serviceable.

Its prime value is to clear end-zone faults such as F1 in Fig. 4, since zone 1 clears the closer faults at high speed. When a zone 3 operation counter reaches 2, ORTT keys the transmitter associated with that line. This signal (30-300kHz) may be coupled to a phase wire of the protected line or sent over a telephone or microwave channel. Receipt of this information indicates that the remote-end relays see fault-power flow into the protected line. If the local zone 3 also operates, ORTT immediately trips, provided a coordinating time delay has elapsed since zone 3 first operated. This delay equals the channel drop-out time plus 4 ms.

OBK provides continuous transmitter keying when the line is disconnected from the station, so the remote zone 3 can trip immediately should the other end be closed on a faulted line. OBK also uses its breaker position information to advise the potential-selection logic when the line again connects to the station. This logic prevents the program from using isolated line potential for relaying of the other lines on the same kv level. Transfer to an alternative source occurs when the breaker trip circuit is energized either by the computer or by non-automatic means.

h. Line-Current Peak-Change Supervision

Z3PH contains logic to prevent line-breaker tripping due to

potential-circuit trouble with the power system normal. If, for example, a potential fuse blows, VFD erroneously detects a fault. Even though FLOC fails to find a fault, EX will call Z3PH. Unless Z3PH detects a 0.1 pu change in peak magnitude compared to the previous peak or the time interval between these peaks is abnormal, tripping is blocked.

i. MA Memory Action

For a nearby AB or 3 phase fault, where V_{AB} drops to nearly zero, MA provides the distance routines with prefault quadrant determinations. EX calls MA each sample to make a QD unless V_{AB} and its first difference both drop below 0.003 pu. MA stores the last 33 QD values. When the voltage is too low for a reliable QD, the program uses the stored QD value determined 33 samples earlier (or a multiple thereof); at 60Hz this is almost a multiple of one cycle ($33 \times 0.5 = 16.5$ ms) so the stored QD values tend to match those which would have been determined had V_{AB} continued normally. The sampling period inaccuracy is tolerable, since the computations are not close to a balance for a nearby fault. However, eventually the drift would become excessive. Accordingly, access to these stored values is blocked after 32 ms.

VI. OTHER PROTECTION

a. BF Breaker Failure

When any routine initiates breaker tripping, it also enters a 64 ms delayed bid for BF(#). After 64 ms, BF checks all phases of each breaker to see that current has ceased flowing (less than 0.05 pu). After 8 samples indicate no current is flowing, BF(#) turns off. If current is still present, the routine operates a multi-contact lockout relay, which latches in the operate position, tripping back-up breakers and blocking reclosing until the lockout relay is manually reset.

b. TOP Turn Off

TOP resets flags and counters, allows VFD to run again and re-structures some of the priorities (see Table II). It will not run if any higher priority routine is suspended or on time-delay bid, with the exception of Z3G/PH and BF delayed bids. The latter routines continue too long to allow low priority fault routines to run in preference to non-fault routines. So the program returns to pre-fault status except when these delayed routines run.

c. Routines Not Included

The areas covered in the above sections are representative, but incomplete. Additional routines could include:

1. Out-of-step tripping of line breakers
2. Automatic reclosing
3. Synchronism verification across an open breaker

4. Automatic synchronization of breaker closing
5. Negative-sequence directional overcurrent protection of the shunt reactors (SR in Fig. 1)
6. Voltage unbalance detection and overcurrent protection of the shunt capacitor bank (CP2 in Fig. 1)

VII. CONCLUSIONS

This study has disclosed no reason to bar eventual application of the digital computer to perform the complete substation protective relaying function. Many existing relay techniques--such as digital logic, level detection and timing--match identical stored-program computer operations. Others with no direct digital counterpart have been developed here; key examples in this category include:

1. Angle comparison (cylinder-unit equivalent)
2. Percentage-differential characteristic
3. Magnetizing-inrush restraint
4. Line-drop compensation
5. Filtering of transients

This paper also has demonstrated how to adapt present-day protection techniques to fit the time-sharing, sampled-data computer world. For example, fault-detecting and locating logic has been devised to take control away from non-fault routines and to direct the program to the routines most likely to effect fast breaker tripping.

The following salient advantages to the use of a computer are foreseen:

1. Faster breaker tripping, with security against undesired operations comparable to existing relays. (The logic here

provides 4 ms nominal trip time.)

2. Greater dependability, since the hardware is in frequent use as contrasted to the protracted idleness of existing hardware.
3. More economical. Cost can be shared with non-protective functions for data acquisition and control.
4. Readily adaptable to use with digital current and potential transducers.

While long-range optimism seems justified, many roadblocks promise to deter the development of an economical, serviceable system. Some of the likely key problem areas are:

1. Programming effort Based upon an experienced real-time programmer being able to write and debug 10 program statements per day¹, many man years must be expended.
2. Input requirements The instantaneous value of each ac current and voltage must be converted to digital form every 0.5 ms (372 quantities in Fig. 1).
3. Computer Speed The program imposes massive speed requirements. For example, six passes of Z1GS² should be performed in 0.3 ms, requiring a total of 54 multiply, 162 add and 6 left-shift operations. Also storage of converted ac inputs should not

1. A rule of thumb in the vogue in the author's company.
2. Eqs. (33) to (49), (56) to (59) in App. E.

entail more than 0.2 ms of main-frame time (372 inputs in Fig. 1).

4. Security The computer will find the substation environment most inhospitable. Much programming and analog-to-digital-conversion hardware effort will be needed to keep undesired breaker tripping to tolerable levels.

VIII. RECOMMENDATIONS

This thesis represents only a rudimentary attempt at organizing an approach to the problem. No practical analysis has been made relative to the state of the art in areas of A-D conversion and machine speed. Are process computers available to handle the speed requirements? What kind of fast-memory is needed and how much? Do parallel accumulators offer a significant advantage? What kind of reliability could be expected? Are the economics now favorable? How could the program be better organized to reduce cost, main-frame duty, memory needs and operating time? These are questions for someone well versed in computer technology.

APPENDIX ADEFINITIONS

APP.	Appendix
CT	Current Transformer
CTR	Counter
d	$ Z_{OM}/Z_{OL} $, a stored constant for each line
DECR	Decrement
Differential Current	Summation of all currents flowing into a protective zone (e.g. bus 1 in Fig. 1)
First Difference	Present sample value minus the previous sample value
h	Sampling interval, seconds
H ₁	L ₁ /h, a stored constant for each line
H ₂	L ₂ /h, a stored constant for each line
H ₃	L ₃ /h, a stored constant for each line
H ₀₁	L ₀₁ /h, a stored constant for each line
H ₀₂	L ₀₂ /h, a stored constant for each line

H_{03}	L_{03}/h , a stored constant for each line
I_A, I_B, I_C	Phase currents, instantaneous
$\dot{I}_A, \dot{I}_B, \dot{I}_C$	Phase currents, phasor
I'_A, I'_B, I'_C	Phase A first difference (prime always connotes first difference)
I''_A, I''_B, I''_C	Phase A second difference (double prime always connotes second difference)
I_{BK}	Breaker current (any phase), instantaneous
I_D	Delta current (difference of two phase currents), instantaneous
I_L	Transmission-line currents, instantaneous
I_O	Zero-sequence current, instantaneous
I_{OM}	Parallel-line zero-sequence current, instantaneous
I_P	Value of latest current peak
I_{P-1}	Value of previous current peak
I_P (ss)	Value of steady-state current peak
INCR	Increment
K	Sample designation (e.g. $(I_A)_K$)

L_1, L_2, L_3	Positive-sequence line inductance of zone 1, zone 2 and zone 3, respectively
L_{01}, L_{02}, L_{03}	Zero-sequence line inductance of zone 1, zone 2 and zone 3, respectively
pu	Per unit (69V, rms; 5A, rms)
PT	Potential transformer or capacitance device
R_1, R_2, R_3	Positive-sequence line resistance of zone 1, zone 2 and zone 3, respectively
Residual Current	$3I_0$, instantaneous
R_{01}, R_{02}, R_{03}	Zero-sequence line resistance of zone 1, zone 2 and zone 3, respectively
Routine Abbreviations	See Table I
Routine States:	
Running	In operation
Bidding to run	Awaiting completion of higher priority routines
Time Delay	Awaiting preset time interval to elapse
Suspended	Awaiting information from some other routine
Executive turnoff	Machine preempted by higher priority

	routine or by lower priority program running under hardware or software lockout
Turned off	
Second Difference	Present first difference minus the previous sample's first difference
V_0	Zero-sequence voltage, instantaneous
$3V_0$	Residual voltage = $V_{AG} + V_{BG} + V_{CG}$, (instantaneous)
V_{AG}, V_{BG}, V_{CG}	Phase-to-ground voltages, instantaneous
Z_{OL}	Zero-sequence line impedance to remote station
Z_{OM}	Zero-sequence mutual impedance between the protected line and a parallel line
Zone	A protective zone: transmission line, bus, transformer, etc., usually bounded by circuit breakers
(#)	Used to denote specific zone, rather than complete set (e.g. $Z3G(\#)$ vs $Z3G$)

APPENDIX B

VFD SPEED/SENSITIVITY

1. Single Phase to Ground Faults

The residual voltage $3V_0$ and its first difference $3V_0'$ are defined in App. A. Fig. 5 shows that the first difference at sample 0 will be larger if the fault occurs when $3V_0$ is at other than 0° , due to the jump in voltage at inception. Fig. 5(b) represents the most unfavorable situation with sample 0 at 10° from inception and sample 1 at 20.8° . For this case the magnitudes and first differences for a unit of $3V_0$ at 60 Hz are:

<u>Sample</u>	<u>$3V_0$</u>	<u>$3V_0'$</u>
-1	0	0
0	0.174	0.17
1	0.355	0.18
2	0.524	0.17

Using the Maximum $|3V_0'|$ of 0.18, the minimum $3V_0$ peak to yield a $|3V_0'|$ of 1/64 is:

$$(3V_0) \text{ min.} = \frac{1}{64 \times 0.18} = 0.09 \text{ pu}$$

$$= (0.09) (3) (69) = 18. \text{V, rms.}$$

If the fault occurs at 90° :

$$(3V_0) \text{ min.} = 1/64 = 0.016 \text{ per unit, or 3. V, rms.}$$

So the ground detection sensitivity ranges from 0.016 to 0.09 pu (3-18 V, rms) depending upon fault incidence angle. This analysis assumes zero residual voltage prior to the fault. In practice, both fundamental and triple harmonics exist. Load or line-impedance unbalance produces fundamental residual voltage, while transformer nonlinearities produce the triple harmonics. The maximum normal $3V_0$ which will not operate VFD is:

	$\frac{ 3V_0' }{\text{max.}}$	$\frac{3V_C \text{ max., rms.}}{\text{max., rms.}}$
60 Hz	0.188	17.
180 Hz	0.564	6.

These values are quite ample to insure no misoperation of VFD.

Detection occurs at sample 0 or 1, which yields a maximum time of 1 ms, excluding machine time.

2. Three Phase Faults

Phase faults are detected by a drop in peak magnitude of V_{AG} , V_{BG} , V_{CG} , V_{AB} , V_{BC} or V_{CA} . Since an apparent peak can occur where the pre-fault voltage is in quadrant I or III, as in Fig. 6(a), a 3-phase fault can always be detected at sample 0 unless the voltage collapse is too small as in Fig. 6(b). Since the six voltages enumerated have peaks spaced at 30° intervals, some of these will always be in either quadrant I or III.

Fig. 11 illustrates how the required collapse must exceed the first difference. As an approximation the pre-fault and post-fault sinusoids are assumed to be linear and their first difference equal to the maximum

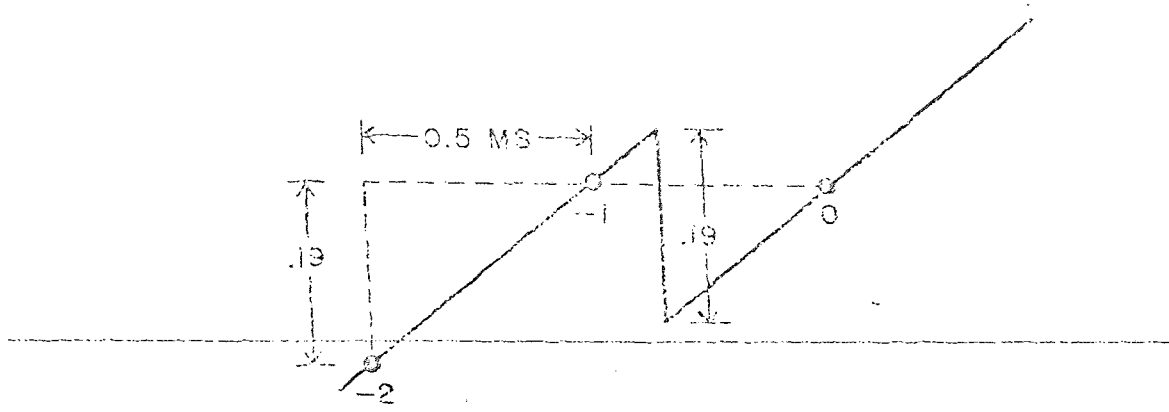

ENL 11

AN APPARENT PEAK WILL BE DETECTED IF THE DROP EXCEEDS 0.19 PER UNIT

value of 0.19 which occurs when the samples straddle zero. Then regardless of where samples -1 and 0 occur in this region, the collapse must exceed 0.19pu to detect the fault at sample 0. Actually, the collapse need only be about half this amount since another voltage would be about 60° from zero and its first difference would be about 0.09pu. The voltage at 60° is 0.37pu pre-fault, so the required voltage collapse is about 10%. For lesser drops VFD waits for an actual peak, as in Fig. 6(b) and (c). Since these peaks occur every 30° , the maximum detection time is at sample 3 (10.8° per sample).

3. Phase to Phase Fault

Fig. 12(a) represents the most unfavorable time for a distant fault. Assuming V_{AB} and V_{CA} peaks do not drop by $1/64$ pu and an apparent peak of V_{BG} , V_{CG} , or V_{BC} cannot be detected in quadrants I and III, VFD must await the next V_{CG} peak about 115° later. Operation would occur at sample 11.

For a fault somewhat closer, the peaks of V_{AB} and V_{CA} will also drop $1/64$ below pre-fault level, decreasing maximum detection time to about 60° (sample 6).

For the close-in fault of Fig. 12(b), V_{AB} drops from 0.92 to 0.58 pu creating an apparent peak at sample 0. If the fault occurs about 30° later when V_{AB} (pre-fault), shown dotted, is in quadrant II, none of the voltages experience an apparent peak, so VFD must await a V_{BG} peak at about sample 2. If the fault occurs about 60° later than shown in Fig. 12(b), after V_{BG} , V_{CG} , V_{AB} and V_{CA} are past peak, V_{BC} will be in

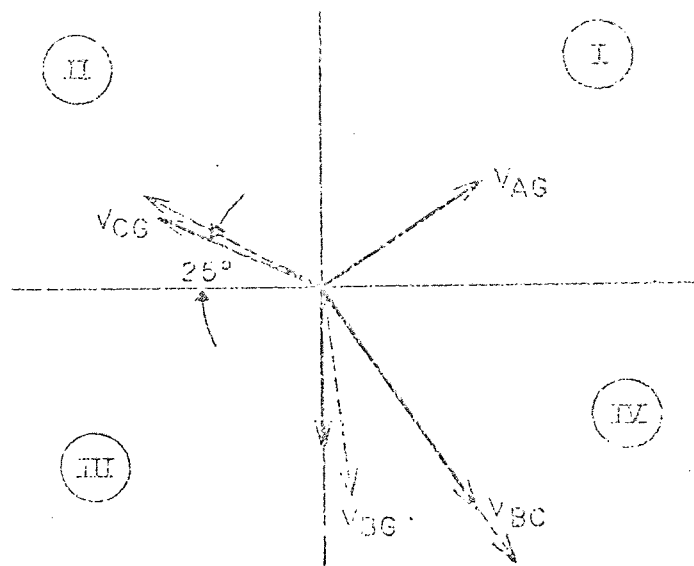

(a) DISTANT FAULT

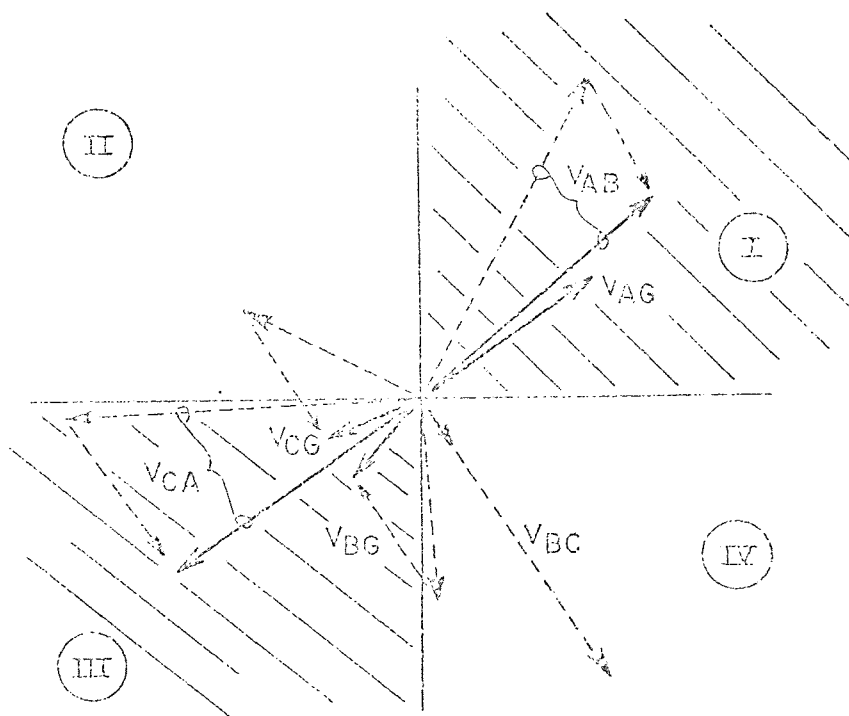

(b) NEARBY FAULT

FIG. 12 VOLTAGE CONDITIONS FOR BC FAULTS

quadrant I and will have an apparent peak. If the fault should occur 150° later, after V_{BC} passes into quadrant II, V_{BG} has an apparent peak at sample 0. This situation continues until about 180° beyond the position shown in Fig. 12(b), at which point the above sequences repeat for the next 180° .

APPENDIX CTIME TO CURRENT-TRANSFORMER SATURATION

Even high quality current transformers will saturate due to dc offset current transients unless their decrement is quite fast. The time required for the transformer to saturate¹ is a function of:

E_S = rms voltage at which the CT saturates

I = rms steady-state secondary fault current

R = burden resistance, including CT winding

T = dc time constant of primary current

For example, let $E_S = 400V$, $I = 200A$, $R = 2$ ohms and $T = 2$ cycles (33 ms). Saturation occurs at 0.24 cycles, or 4 ms following fault inception.

1. Fig. 6 of Ref. 2

APPENDIX DINDUCTIVE-DROP ERRORS USING FIRST DIFFERENCE

The inductive drop may be approximated at any instant by the expression:

$$L \frac{di}{dt} = L \frac{I'}{h} \quad (4)$$

where $i = \sin 377t$ (1pu current)

$$\frac{di}{dt} = 377 \cos 377t \text{ units/sec}$$

$$I' = I_K - I_{K-1}$$

$$I_K = \sin 377t$$

$$I_{K-1} = \sin (377t - 0.188)$$

$$h = 0.5 \text{ ms or } 0.188 \text{ radians}$$

The error E in approximating the current derivative is:

$$E = 377 \cos 377t - 2000 \sin 377t - \sin (377t - 0.188) \quad (5)$$

Fig. 13 plots this error. Note that the percentage error is intolerable. It can be reduced to less than 1% by averaging the first difference for samples K and $K + 1$ for use in the K -sample calculations, when the current is in quadrant I or III. When the current is in quadrant II or IV, I_K and I_{K-1} are averaged for the K -sample calculations.

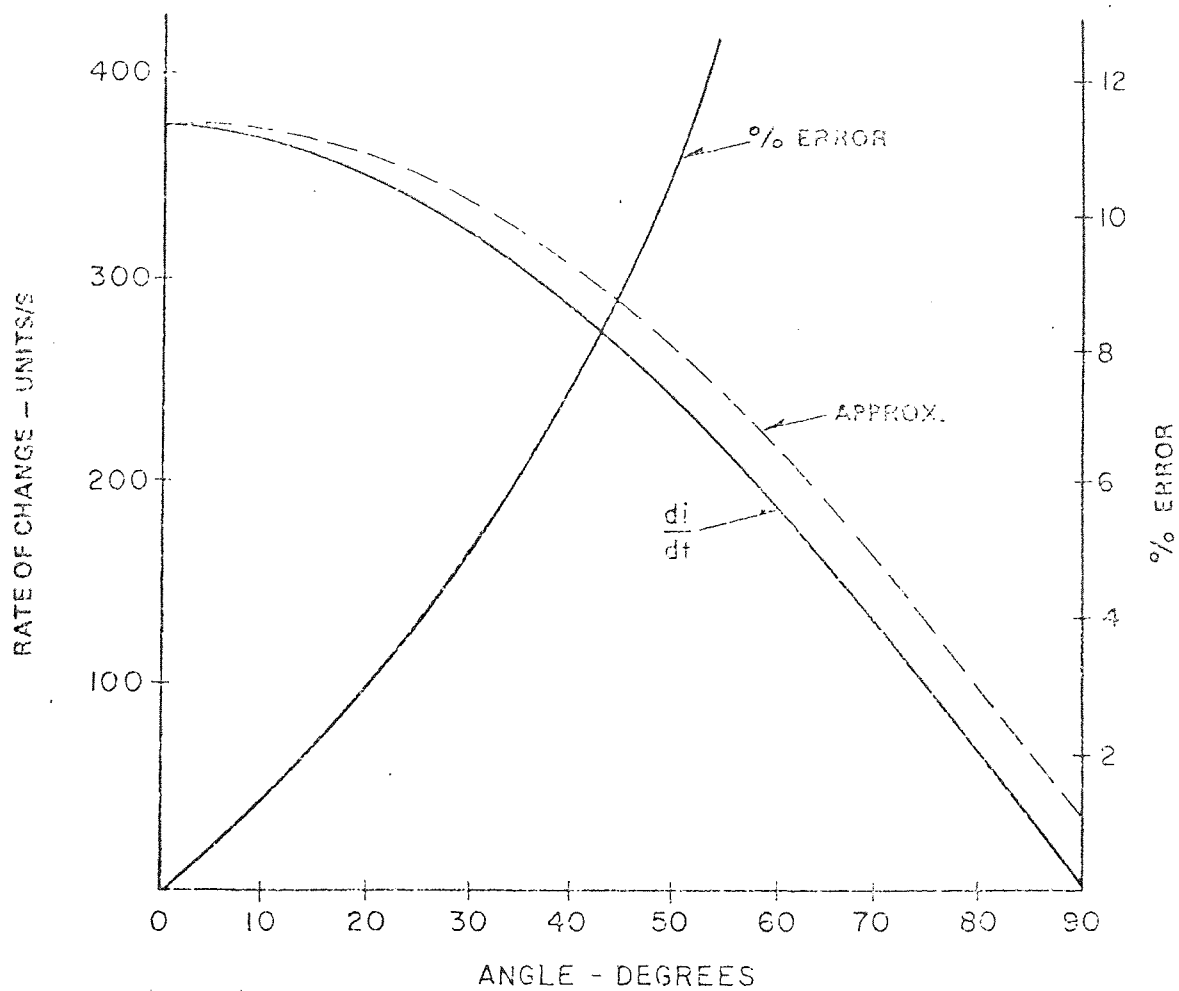

FIG. 13

ERROR IN USING FIRST DIFFERENCE OF SINUSOID

APPENDIX EDISTANCE-ROUTINE CALCULATIONS

The following equations define the machine operations required for distance relaying. The currents and voltages are instantaneous pu values of ac quantities. See App. A for definition of terms. App. G gives a numerical example.

a. Operations Common to All Zones

$$V_{AB} = V_{AG} - V_{BG} \quad (6)$$

$$V'_{AB} = (V_{AB})_K - (V_{AB})_{K-1} \quad (7)$$

$$V''_{AB} = (V'_{AB})_K - (V'_{AB})_{K-1} \quad (8)$$

$$I_O = 1/3 (I_A + I_B + I_C) \quad (9)$$

$$I_{AD} = I_A - I_O \quad (10)$$

$$I_{BD} = I_B - I_O \quad (11)$$

$$I_{CD} = I_C - I_O \quad (12)$$

$$I'_{AD} = (I_{AD})_K - (I_{AD})_{K-1} \quad (13)$$

$$I''_{AD} = (I'_{AD})_K - (I'_{AD})_{K-1} \quad (14)$$

$$I'_{ADA} = 1/2 \left[(I'_{AD})_K + (I'_{AD})_{K+1} \right] \\ \text{(If } I_{AD} \text{ is in quadrant I or III)} \quad (15)$$

$$I'_{ADA} = 1/2 \left[(I'_{AD})_K + (I'_{AD})_{K-1} \right] \\ \text{(If } I_{AD} \text{ is in quadrant II or IV)} \quad (16)$$

$$I'_{BD} = (I_{BD})_K - (I_{BD})_{K-1} \quad (17)$$

$$I''_{BD} = (I'_{BD})_K - (I'_{BD})_{K-1} \quad (18)$$

$$I'_{BDA} = 1/2 \left[(I'_{BD})_K + (I'_{BD})_{K+1} \right] \quad (I_{BD} \text{ in quad. I or III}) \quad (19)$$

$$I'_{BDA} = 1/2 \left[(I'_{BD})_K + (I'_{BD})_{K-1} \right] \quad (I_{BD} \text{ in quad. II or IV}) \quad (20)$$

$$I'_{CD} = (I_{CD})_K - (I_{CD})_{K-1} \quad (21)$$

$$I''_{CD} = (I'_{CD})_K - (I'_{CD})_{K-1} \quad (22)$$

$$I'_{CDA} = 1/2 \left[(I'_{CD})_K + (I'_{CD})_{K+1} \right] \quad (I_{CD} \text{ in quad. I or III}) \quad (23)$$

$$I'_{CDA} = 1/2 \left[(I'_{CD})_K + (I'_{CD})_{K-1} \right] \quad (I_{CD} \text{ in quad. II or IV}) \quad (24)$$

$$I'_O = (I_O)_K - (I_O)_{K-1} \quad (25)$$

$$I''_O = (I'_O)_K - (I'_O)_{K-1} \quad (26)$$

$$I'_{OA} = 1/2 \left[(I'_O)_K + (I'_O)_{K+1} \right] \quad (I_O \text{ in quad. I or III}) \quad (27)$$

$$I'_{OA} = 1/2 \left[(I'_O)_K + (I'_O)_{K-1} \right] \quad (I_O \text{ in quad. II or IV}) \quad (28)$$

Eqs. (6) to (8) provide polarizing voltage for the 3 phase mho unit¹ of Z1PHS, Z2PHS and Z3PHS. Eqs.

(9) to (28) develop the first differences I_{ADA} , I_{BDA} , I_{CDA} and I_{OA} required to compensate the bus voltages for the inductive line drop. See App. D for the basis for Eqs. (15), (16), (23), (24), (25) and (26).

1 - Ref. 9

b. Operations Common to Z3PHS and Z3GS (Zone 3)

The zero-sequence compensation ² is:

$$V_{OT3} = I_{OR03} + I_{OAH03}^{\prime} \quad (29)$$

The compensated phase-to-ground voltages are:

$$V_{XG3} = V_{AG} - I_{ADR3} - I_{ADAH3}^{\prime} - V_{OT3} \quad (30)$$

$$V_{YG3} = V_{BG} - I_{BDR3} - I_{BDHA3}^{\prime} - V_{OT3} \quad (31)$$

$$V_{ZG3} = V_{CG} - I_{CDR3} - I_{CDAH3}^{\prime} - V_{OT3} \quad (32)$$

c. Z3GS

App. F describes how the magnitude comparison of Ref. 6 is converted to an angle comparison. The compensated zero sequence voltage is:

$$V_{W03} = 1/3 (V_{XG3} + V_{YG3} + V_{ZG3}) \quad (33)$$

$$2V_{W03} = 2/3 (V_{XG3} + V_{YG3} + V_{ZG3}) \quad (34)$$

$$V_{R3} = V_{XG3} - 2V_{W03} \quad (35)$$

$$V_{S3} = V_{YG3} - 2V_{W03} \quad (36)$$

$$V_{T3} = V_{ZG3} - 2V_{W03} \quad (37)$$

$$V_{R3}^{\prime} = (V_{R3})_K - (V_{R3})_{K-1} \quad (38)$$

$$V_{S3}^{\prime} = (V_{S3})_K - (V_{S3})_{K-1} \quad (39)$$

$$V_{T3}^{\prime} = (V_{T3})_K - (V_{T3})_{K-1} \quad (40)$$

$$V_{R3}^{\prime\prime} = (V_{R3}^{\prime})_K - (V_{R3}^{\prime})_{K-1} \quad (41)$$

$$V_{S3}^{\prime\prime} = (V_{S3}^{\prime})_K - (V_{S3}^{\prime})_{K-1} \quad (42)$$

$$V_{T3}'' = (V_{T3}')_K - (V_{T3}')_{K-1} \quad (43)$$

$$V_{XG3}' = (V_{XG3})_K - (V_{XG3})_{K-1} \quad (44)$$

$$V_{YG3}' = (V_{YG3})_K - (V_{YG3})_{K-1} \quad (45)$$

$$V_{ZG3}' = (V_{ZG3})_K - (V_{ZG3})_{K-1} \quad (46)$$

$$V_{XG3}'' = (V_{XG3}')_K - (V_{XG3}')_{K-1} \quad (47)$$

$$V_{YG3}'' = (V_{YG3}')_K - (V_{YG3}')_{K-1} \quad (48)$$

$$V_{ZG3}'' = (V_{ZG3}')_K - (V_{ZG3}')_{K-1} \quad (49)$$

CALL OPX to compare V_{R3} and V_{XG3} ; V_{S3} and V_{YG3} ;

V_{T3} and V_{ZG3}

d. Z3PHS

$$V_{XY3} = V_{XG3} - V_{YG3} \quad (50)$$

$$V_{XY3}' = (V_{XY3})_K - (V_{XY3})_{K-1} \quad (51)$$

$$V_{XY3}'' = (V_{XY3}')_K - (V_{XY3}')_{K-1} \quad (52)$$

$$V_{ZY3} = V_{ZG3} - V_{YG3} \quad (53)$$

$$V_{ZY3}' = (V_{ZY3})_K - (V_{ZY3})_{K-1} \quad (54)$$

$$V_{ZY3}'' = (V_{ZY3}')_K - (V_{ZY3}')_{K-1} \quad (55)$$

CALL OPX to compare V_{XY3} and V_{AB} (reference).

CALL OPY to compare V_{XY3} and V_{ZY3} .

e. Operations Common to Z1PHS and Z1GS (Zone 1)

$$V_{OT1} = I_{OR01} + I_{OAH01} \quad (56)$$

$$V_{XG1} = V_{AG} - I_{ADR1} - I_{ADAH1} - V_{OT1} \quad (57)$$

$$V_{YG1} = V_{BG} - I_{BDR1} - I_{BDAH1} - V_{OT1} \quad (58)$$

$$V_{ZG1} = V_{CG} - I_{CDR1} - I_{CDAH1} - V_{OT1} \quad (59)$$

f. Z1GS

These operations are identical to those of Z3GS, except that here the equations contain terms with the subscript "1" rather than "3". For example, eq. (33) becomes:

$$V_{W01} = 1/3 (V_{XG1} + V_{YG1} + V_{ZG1}) \quad (60)$$

g. Z1PHS

These operations are identical to Z3PHS, except for the use of subscript "1" rather than "3".

h. Operations Common to Z2PHS and Z2GS (Zone 2)

$$V_{OT2} = I_{OR02} + I_{OAH02} \quad (61)$$

$$V_{XG2} = V_{AG} - I_{ADR2} - I_{ADAH2} - V_{OT2} \quad (62)$$

$$V_{YG2} = V_{BG} - I_{BDR2} - I_{BDAH2} - V_{OT2} \quad (63)$$

$$V_{ZG2} = V_{CG} - I_{CDR2} - I_{CDAH2} - V_{OT2} \quad (64)$$

i. Z2GS

These operations are identical to Z3GS, except that here the equations contain terms with the subscript "2" rather than "3". For example, eq.

(33) becomes:

$$V_{WO2} = 1/3 (V_{XG2} + V_{YG2} + V_{ZG2}) \quad (65)$$

Where compensation for zero-sequence mutual induction from a parallel line is desired, redefine

V_{OT2} as:

$$V_{OT2} = (I_0 + I_{CO})R_{O2} + (I'_{OA} + I'_{COA}) H_{O2} \quad (66)$$

(if $|I_{CO}| < |I_0|$)

$$V_{OT2} = I_0 R_{O2} + I'_{OA} H_{O2} \quad (67)$$

(if $|I_{CO}| \geq |I_0|$)

where $I_{CO} = dI_{OM}$ (68)

$$I'_{CO} = (I_{CO})_K - (I_{CO})_{K-1} \quad (69)$$

$$I''_{CO} = (I'_{CO})_K - (I'_{CO})_{K-1} \quad (70)$$

$$I'_{COA} = 1/2 \left[(I'_{CO})_K + (I'_{CO})_{K+1} \right] \quad (71)$$

(if I_{CO} is in quadrant I or III)

$$I'_{COA} = 1/2 \left[(I'_{CO})_K + (I'_{CO})_{K-1} \right] \quad (72)$$

(if I_{CO} is in quadrant II or IV)

Note from the alternative solution for V_{OT2} in Eq. (67) that mutual compensation is not used if the compensating current gets excessive, as it can for nearby parallel-line faults. Compensation is of no value for these faults and results in misoperation.¹

1 - Ref. 6.

j. Z2PHS

These operations are identical to Z3PHS, except for the use of subscript "2" rather than "3".

APPENDIX FCONVERSION OF THE GROUND-DISTANCE MAGNITUDE COMPARISON
TO ANGLE COMPARISON

It is well known that an angle-comparison device can be used to compare the magnitude of two a-c quantities X and Y by reacting (X-Y) and (X + Y); and that a magnitude-comparison device can be used to determine the relative phase-angle position of X and Y by comparing (X-Y) and (X + Y). The ground-distance logic uses such a transformation.

Distance-unit operation should occur when the operating-voltage peak exceeds the restraint-voltage peak regardless of their phase position. However, the program cannot wait for these peaks to occur, since severe faults should be tripped in 4 ms maximum. Therefore, the two voltages are manipulated so that the OPX angle logic may be called.

Fig. 14(a) shows that the angle (b + c) between (X-Y) and (X + Y) is 90° , when $|X| = |Y|$. Since $|X| = |Y|$:

$$a = b \text{ and } c = d \quad (68)$$

Also:

$$a + b = 180^\circ - (c + d) \quad (69)$$

or

$$2b = 180^\circ - 2c \quad (70)$$

$$2(b + c) = 180^\circ$$

$$(b + c) = 90^\circ \quad (71)$$

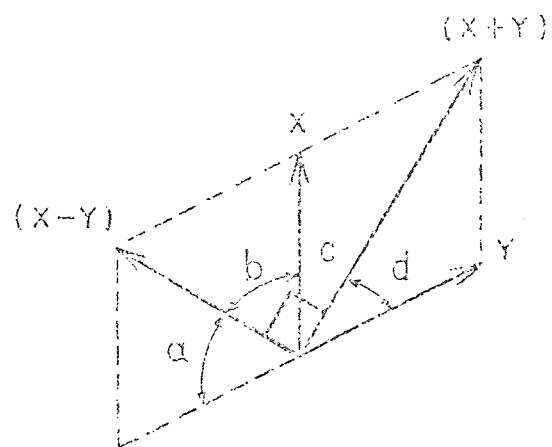

(a) $|X| = |Y|$

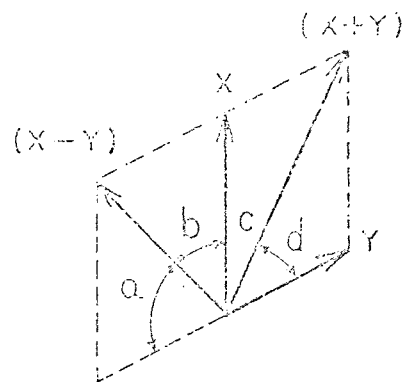

(b) $|X| > |Y|$

FIG. 11

ANGULAR STANDARD OF $(X+Y)$ AND $(X-Y)$

In Fig. 16(b) where $|V| < |X|$:

$$c < d \text{ and } b < a \quad (72)$$

so

$$(b + c) < (a + d) \quad (73)$$

but

$$(a + d) = 180^\circ - (b + c) \quad (74)$$

so

$$(b + c) < 180^\circ - (b + c)$$

or

$$(b + c) > 90^\circ \quad (75)$$

Similarly, if $|Y| > |X|$, then $(b + c) > 90^\circ$.

Accordingly, if operation is required when $|Y| > |X|$, angle logic may be used to operate if $(X - Y)$ leads $(X + Y)$ by $90^\circ - 270^\circ$. Quantity Y , then, is the operate voltage; X , the restraint. From Ref. 6 for phase A (as modified for sampling techniques):

$$X = V_{XN} = (V_{AG} - V_O) - I_{AD}R_3 - I'_{ADA} H_3 \quad (76)$$

$$Y = V_{WO} = V_O - V_{OT3} \quad (77)$$

$$(X + Y) = V_{XN} + V_{WO}$$

$$(X + Y) = V_{AG} - I_{AD} R_3 - I'_{ADA} H_3 - V_{OT3} = V_{XG3} \quad (78)$$

Note that Eq. (78) is the compensated phase to ground voltage.

$$(X - Y) = (X + Y) - 2Y$$

$$(X - Y) = V_{XG3} - 2V_{WO} = V_{R3} \quad (79)$$

Operation should occur when V_{R3} leads V_{XG3} by 90 to 270°.

Comparable operations exist for phases B and C.

APPENDIX G

DISTANCE-ROUTINE EXAMPLE

1. General

A phase-A-to-ground fault occurs in Fig. 15 on line M-N, 75% of M-N from M. Prefault currents are neglected. Prefault voltages at the fault point are 1 pu with the phase A voltage at zero degrees for reference. Impedances are in ohms at 138KV. Positive-sequence values use the subscript "1", while the zero-sequence impedances use the subscript "0".

Fig. 15 lists the per-unit steady-state current and voltage inputs to the computer, which were calculated using symmetrical component principles¹. The actual inputs included the d-c transient as well. The voltage transient and the d-c current decrement are neglected. Prefault voltage on phase A at the fault is V_{AGF}' . Fig. 16 shows the input quantities, assuming a fault at a V_{AGF}' angle of 40° , with the first post-fault sample arbitrarily at a V_{AGF}' angle of 45.8° .

Note in Fig. 16 that V_{AG} experiences a sudden drop; however, Table IV shows that V_{AG} is higher at sample 0 than at sample -1 so VFD does not see an apparent peak. VFD does operate, though, since $3V_0' = 0.072$ at sample 0 ($1/64 = 0.016$ required).

2. Zone 3

Table IV performs the Z3GS computations based on App. E and F, with

1. Ref. 11, pp. 26-72

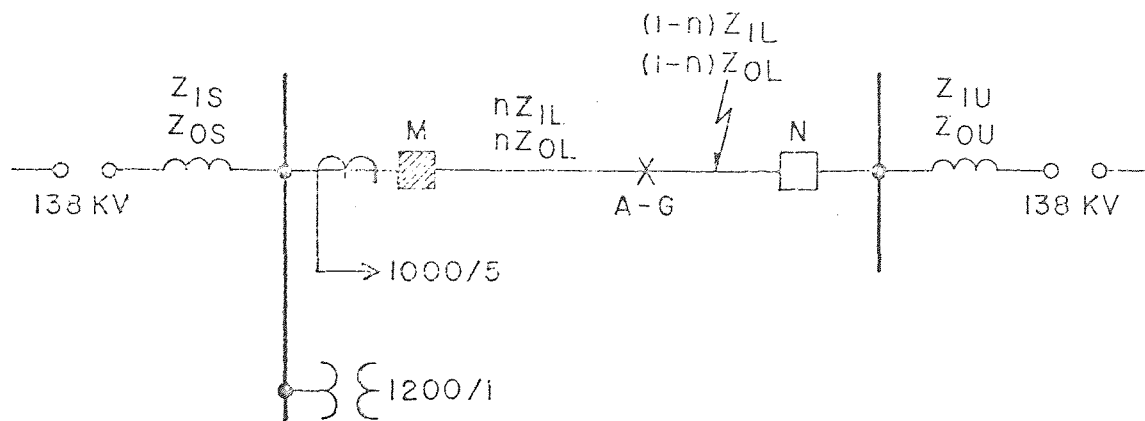

IMPEDANCES IN OHMS AT 138kV, 60 Hz:

$Z_{IS} = 0.05 + j 10$	$Z_{IU} = 0.10 + j 11.5$
$Z_{OS} = 0.02 + j 5$	$Z_{OU} = 0.13 + j 10.7$
$nZ_{IL} = 1.5 + j 22.5$	$(1-n)Z_{IL} = 0.5 + j 7.5$
$nZ_{OL} = 7.5 + j 67.5$	$(1-n)Z_{OL} = 2.5 + j 22.5$

PER UNIT QUANTITIES FOR FAULT AT X:

$V_{AGF} = 1.00 \angle 0^\circ$	$I_A^{(SS)} = 1.86 \angle -85.8^\circ$
$V_{AG} = 0.812 \angle -0.9^\circ$	$I_B^{(SS)} = 0.032 \angle 91.9^\circ$
$V_{BG} = 0.976 \angle -117.7^\circ$	$I_C^{(SS)} = 0.032 \angle 91.9^\circ$
$V_{CG} = 0.982 \angle 117.6^\circ$	

FIG. 15 PHASE A-TO-GROUND FAULT EXAMPLE

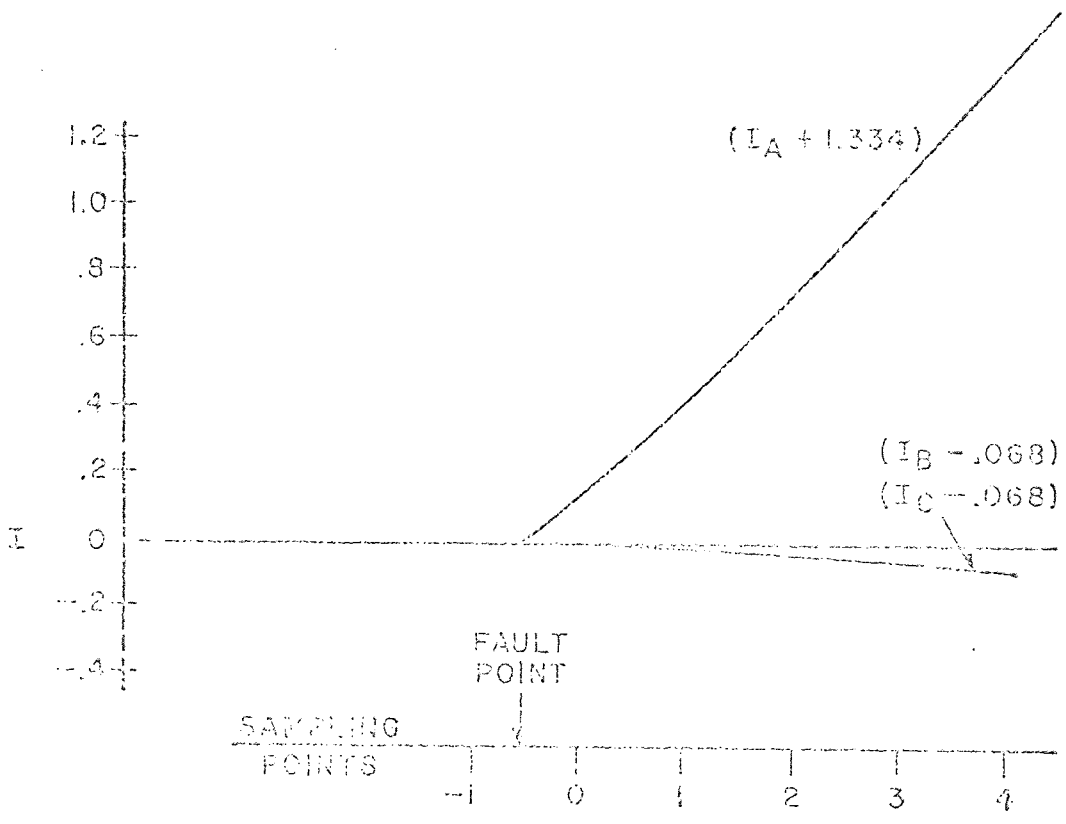
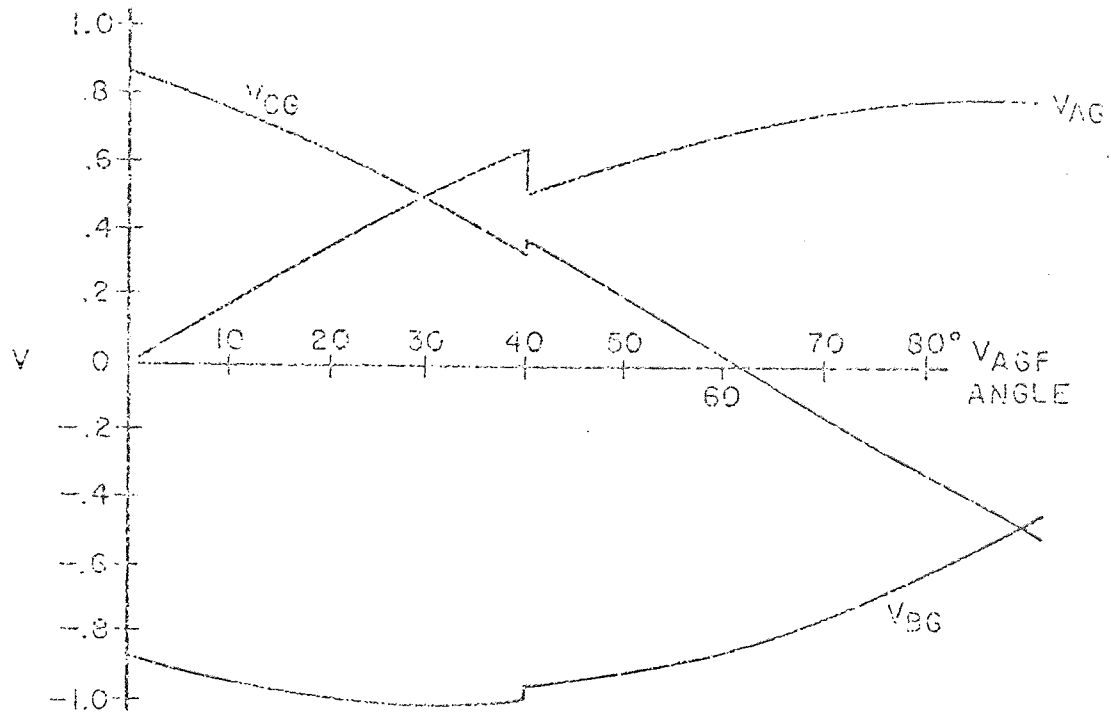

EMULSA INPUT ALPHANUMERICS

computer operations beginning with the $3I_o$ calculations. Current first differences are averaged per App. D to obtain I'_{OA} , I'_{ADA} and $I'_{BDA} = I'_{CDA}$. At sample 4, Z3GS increments the phase A operation counter based on OPX logic described in Section V. At this point Z3GS advances Z1GS and Z1PH priority to 3. On the next pass (5), V_{R3} moves to quadrant II, but V_{XC3} is delayed in moving to quadrant IV until sample 6. According OPX does not increment the phase A operation counter at sample 5 since V_{R3} and V_{XC3} are caught in adjacent quadrants. So transmitter keying occurs at sample 6, which is one sample later than the minimum. From a time standpoint transmitter keying occurs at sample 7 since the currents progress to quadrant I at sample 5 where the adjusted first-difference uses the $K + 1$ sample. Therefore, keying occurs about 4 ms after the fault, assuming a solid-state interface between the computer and the transmitter.

Z3G requires that $|3I_o'| > 0.04$. At sample 0 $|3I_o'| = 0.126$, so Z3G may operate.

Zone 3 is set to reach 200% of the line M-N impedance. For example:

$$\begin{aligned} Z_B &= \text{base impedance} = \frac{\text{base voltage}}{\text{base current}} \\ &= \frac{69.3}{5} = 13.85 \text{ ohms} \end{aligned}$$

$$R_C = \text{CT ratio} = 1000/5 = 200$$

$$R_V = \text{PT ratio} = 138,000/115 = 1200$$

TABLE IV FAULT EXAMPLE - Z3GS

QUANTITY	SAMPLE -1		FAULTED VALUES AT INCEPTION		SAMPLE 0		SAMPLE 1		SAMPLE 2		SAMPLE 3	
	ANGLE	MAGNIT.	ANGLE	MAGNIT.	ANGLE	MAGNIT.	ANGLE	MAGNIT.	ANGLE	MAGNIT.	ANGLE	MAGNIT.
V _{AG}	35.0°	0.573	39.1°	0.509	44.9°	0.574	55.7°	0.670	66.5°	0.744	77.3°	0.792
V _{BG}	-85.0	-0.996	-77.7	-0.952	-71.9	-0.927	-61.1	-0.853	-50.3	-0.751	-39.5	-0.620
V _{CG}	155.0	0.423	157.6	0.374	163.4	0.281	174.2	0.099	185.0	-0.086	195.8	-0.267
I _A (SS)	0	0	-45.8	-1.334	-40.0°	-1.196	-29.2	-0.908	-18.4	-0.587	-7.6	-0.246
I _B (SS)	0	0	131.9	0.068	137.7	0.062	148.5	0.408	159.3	0.032	170.1	0.016
I _C (SS)	0	0	131.9	0.068	137.7	0.062	148.5	0.408	159.3	0.032	170.1	0.016
I _A +1.334			0	0		0.138		0.426		0.747		1.088
I _B -0.068			0	0		-0.006		-0.020		-0.036		-0.052
I _C -0.068			0	0		-0.006		-0.020		-0.036		-0.052
3V ₀						-0.072		-0.084		-0.093		-0.095
3V ₀						0.072		0.012		0.009		0.002

QUANTITY	SAMPLE 4		SAMPLE 5		SAMPLE 6		SAMPLE 7		SAMPLE 8	
	ANGLE	MAGNIT.	ANGLE	MAGNIT.	ANGLE	MAGNIT.	ANGLE	MAGNIT.	ANGLE	MAGNIT.
V _{AG}	88.1°	0.811	98.9°	0.802	109.7°	0.764	120.5°	0.700	131.3°	0.610
V _{BG}	-28.7	-0.469	-17.9	-0.299	-7.1	-0.121	3.7	0.063	14.5	0.244
V _{CG}	206.6	-0.440	217.4	-0.596	228.2	-0.732	239.0	-0.842	249.8	-0.922
I _A (SS)	3.2	0.104	14.0	0.450	24.8	0.781	35.6	1.083	46.4	1.348
I _B (SS)	180.9	-0.001	191.7	-0.019	202.5	-0.035	213.3	-0.051	224.1	-0.064
I _C (SS)	180.9	-0.001	191.7	-0.019	202.5	-0.035	213.3	-0.051	224.1	-0.064
I _A +1.334		1.438		1.784		2.115		2.417		2.686
I _B -0.068		-0.069		-0.088		-0.103		-0.119		-0.132
I _C -0.068		-0.069		-0.088		-0.103		-0.119		-0.132

TABLE IV - CONTINUED
 FAULT EXAMPLE - Z3G5

QUANTITY	SAMPLE								
	0	1	2	3	4	5	6	7	8
$3I_0$	0.126	0.386	0.675	0.984	1.300	1.608	1.909	2.179	2.424
I_0	0.042	0.129	0.225	0.328	0.433	0.536	0.636	0.726	0.808
I_0'	X	0.087	0.096	0.103	0.105	0.103	0.100	0.090	0.082
I_0''	X	X	0.009	0.007	0.002	-0.002	-0.003	-0.010	-0.018
I_0 GD	X	X	IV	IV	IV	I	I	I	I
I_0A	X	X	0.092	0.100	0.104	0.102	0.0905	0.086	X
I_{AD}	0.096	0.297	0.522	0.760	1.005	1.248	1.479	1.691	1.878
I_{AD}'	X	0.201	0.225	0.238	0.245	0.243	0.231	0.212	0.187
I_{AD}''	X	X	0.024	0.013	0.007	-0.002	-0.008	-0.019	-0.025
I_{AD} GD	X	X	IV	IV	IV	I	I	I	I
I_{ADA}	X	X	0.213	0.232	0.242	0.237	0.222	0.200	X
$-I_0R_{03} = -0.241I_0$	X	X	-0.054	-0.079	0.104	-0.129	-0.154	-0.175	-0.195
$-I_0A H_{03} = -11.49I_0A$	X	X	-1.057	-1.149	-1.194	-1.171	-1.091	-0.988	X
$-V_{OT3} = -I_0R_{03} - I_0A H_{03}$	X	X	-1.111	-1.228	1.298	-1.300	-1.245	-1.163	X
$-I_{AD}R_3 = -0.048 I_{AD}$	X	X	-0.025	-0.036	-0.048	-0.060	-0.071	-0.081	X
$-I_{ADA} H_3 = -3.83 I_{ADA}$	X	X	-0.816	-0.888	0.926	-0.908	-0.846	-0.766	X
$-0.048 I_{AD} - 3.83 I_{ADA} - V_{OT3}$	X	X	-1.952	-2.157	2.272	-2.268	-2.162	-2.010	X
$V_{XG3} = V_{AG} - 0.048 I_{AD} - 3.83 I_{ADA} - V_{OT3}$	X	X	-1.208	-1.360	1.461	-1.466	-1.398	-1.310	X
$I_{BD} = I_{CD}$	-0.048	-0.149	-0.261	-0.380	0.502	-0.624	-0.739	-0.845	-0.940
$I_{BD}' = I_{CD}'$	X	-0.101	-0.112	-0.119	0.122	-0.122	-0.115	-0.106	-0.095
$I_{BD}'' = I_{CD}''$	X	X	-0.011	-0.007	0.003	0	0.007	0.009	0.011
I_{BD} GD	X	X	II	II	II	III	III	III	III
$I_{BDA} = I_{CDA}$	X	X	-0.106	-0.116	0.120	-0.118	-0.110	-0.100	X
$-I_{BD}R_3 = -0.048 I_{BD}$	X	X	0.013	0.018	0.024	0.030	0.036	0.041	X
$-I_{BDA} H_3 = -3.83 I_{BDA}$	X	X	0.406	0.444	0.460	0.454	0.421	0.383	X
$-I_{BD} H_3 - I_{BDA} H_3 - V_{OT3}$	X	X	-0.692	-0.756	0.834	-0.816	-0.788	-0.739	X
$V_{YG3} = V_{BG} - I_{BD}R_3 - I_{BDA}H_3 - V_{OT3}$	X	X	-1.443	-1.386	1.303	-1.115	-0.909	-0.676	X
$V_{ZG3} = V_{CG} - I_{CD}R_3 - I_{CDA}H_3 - V_{OT3}$	X	X	-0.778	-1.033	1.274	-1.412	-1.520	-1.581	X

TABLE IV -- CONTINUED
 FAULT EXAMPLE - Z3GS

QUANTITY	SAMPLE						
	2	3	4	5	6	7	
$3V_{W03} = V_{XG3} + V_{YG3} + V_{ZG3} - 2V_{W03}$	-3.429	-3.779	-4.038	-3.993	-3.827	-3.567	
$V_{R3} = V_{XG3} - 2V_{W03}$	2.286	2.519	2.692	2.662	2.552	2.378	
$V_{S3} = V_{YG3} - 2V_{W03}$	0.978	1.159	1.231	1.196	1.154	1.068	
$V_{T3} = V_{ZG3} - 2V_{W03}$	0.843	1.133	1.389	1.547	1.643	1.702	
V^I_{R3}	1.508	1.486	1.418	1.250	1.032	0.797	
V^I_{S3}	X	0.181	0.072	-0.035	-0.042	-0.086	
V^I_{T3}	X	0.290	0.256	0.158	0.096	0.059	
V^{II}_{R3} SIGN	X	-0.022	-0.072	-0.168	-0.218	-0.235	
V^{II}_{S3} SIGN	X	X	-	-	-	-	
V^{II}_{T3} SIGN	X	X	-	-	-	-	
V_{R3} QD	X	X	I	II	II	II	
V_{S3} QD	X	X	I	I	I	I	
V_{T3} QD	X	X	II	II	II	II	
V^I_{XG3}	X	-0.152	-0.101	-0.005	0.068	0.088	
V^I_{YG3}	X	0.047	0.083	0.188	0.206	0.233	
V^I_{ZG3}	X	-0.255	-0.241	-0.138	-0.108	-0.061	
V^{II}_{XG3} SIGN	X	X	+	+	+	+	
V^{II}_{YG3} SIGN	X	X	+	+	+	+	
V^{II}_{ZG3} SIGN	X	X	+	+	+	+	
V_{XG3} QD	X	X	III	III	IV	IV	
V_{YG3} QD	X	X	IV	IV	IV	IV	
V_{ZG3} QD	X	X	III	III	III	III	
PH. A OPX OPERATION COUNTER	X	X	(1) INCR.	X	(?) INCR.	INCR.	
PH. B OPX OPERATION COUNTER	X	X	X	X	X	X	
PH. C OPX OPERATION COUNTER	X	X	X	X	X	X	

(1) ADVANCE
 ZONE 1 PRIORITY

(2) KEY
 TRANSMITTER

$$L_{\text{relay}} = \frac{Z_{\text{pri}}}{2I_{\text{f}}} \times \frac{R_{\text{C}}}{R_{\text{V}}} \times \frac{1}{Z_{\text{B}}} \text{ pu}$$

$$\begin{aligned} L_3 &= \left(\frac{2Z_{\text{1L}}}{2I_{\text{f}}}\right) \left(\frac{R_{\text{C}}}{R_{\text{V}}}\right) \times \frac{1}{Z_{\text{B}}} \\ &= \left(\frac{60.0}{377}\right) (0.167) \left(\frac{1}{13.85}\right) = 0.00192 \text{ pu} \end{aligned}$$

$$H_3 = \frac{L_3}{h} = (0.00192) (2000) = 3.83 \text{ pu}$$

H_3 multiplies times I_{ADA} , the averaged first difference of positive-plus negative-sequence current, to generate the zone 3 positive-and negative-sequence inductive line-drop compensation.

Fig. 17 shows the phasor relations for Z3GS at sample 2. Input voltages V_{AG} , V_{BG} , V_{CG} are compensated by the line currents to produce V_{XC3} , V_{YG3} and V_{ZG3} , respectively; these are further modified by subtracting $2V_{\text{WO3}}$ to produce V_{R3} , V_{S3} and V_{T3} , respectively. OPX compares the quadrant positions of V_{R3} and V_{XC3} , V_{S3} and V_{YG3} , V_{T3} and V_{ZG3} . Were OPX operative at sample 2, all phase operation counters would be incremented since the three pairs occupy non-adjacent quadrants. By sample 4 V_{YG3} has moved to quadrant IV so that V_{S3} and V_{YG3} are in adjacent quadrants; OPX neither decrements, nor increments the phase B counters. Also by sample 4, V_{T3} moves to quadrant II, so V_{T3} and V_{ZG3} are in adjacent quadrants.

While the $V_{\text{S3}}-V_{\text{YG3}}$ and $V_{\text{T3}}-V_{\text{ZG3}}$ angles exceed 90° , which is an operate condition, they occupy non-adjacent quadrants for relatively short periods of time. So slow operation could result if the routine depended upon these comparisons. However, V_{R3} and V_{XC3} are almost 180°

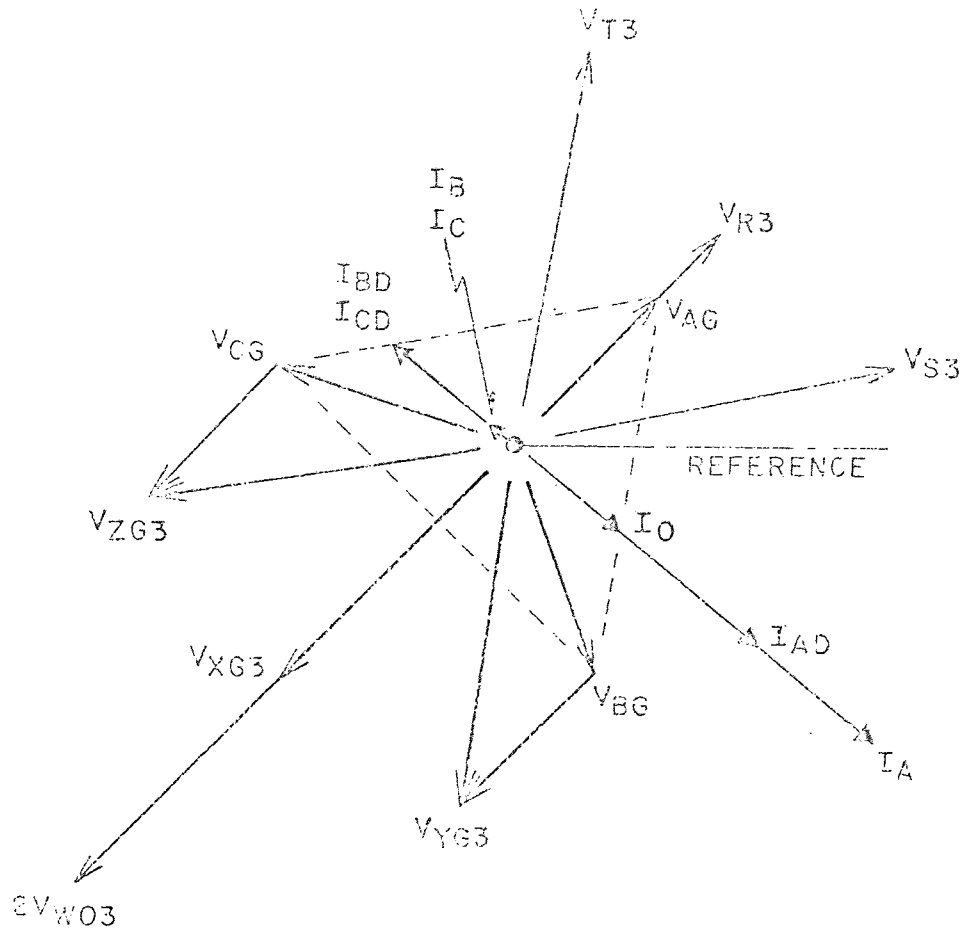

FIG. 17. ZSGS PHASOR RELATIONS AT SAMPLE 2

out of phase, so they almost exclusively occupy non-adjacent quadrants. Only occasionally at quadrant transitions (such as sample 5) do V_{R3} and V_{XG3} occupy adjacent quadrants for this fault.

3. Zone 1

Table V for Z1GS utilizes the current calculations of Table IV. Ground distance reach is set for 85% of line M-N impedance, so the fault is at 88% of relay reach. V_{R1} and V_{XG1} occupy about the same phase positions as for Z3GS. While the phase B and C voltages occupy somewhat different phase positions, as compared to Z3GS, they fall in the same quadrants as for Z3GS. Accordingly, counter incrementing occurs during the same samples.

While tripping occurs at sample 6, in the computations, first difference averaging requires the use of sample 7, so breaker tripping occurs after sample 7 (in time) or at about 4 ms. This is one sample longer than the minimum.

Z1GS starts computing at sample 0, although it is not called until after sample 4. Unless the computer duty is excessive, a ten-sample buffer is ample.

TABLE V FAULT EXAMPLE - ZIGS

QUANTITY	SAMPLE NUMBER					
	2	3	4	5	6	
- I ₀ R ₀ = - 0.102 I ₀	- 0.023	- 0.033	- 0.044	- 0.055	- 0.065	
- I' _{0A} H ₀₁ = - 4.88 I' _{0A}	- 0.448	- 0.488	- 0.507	- 0.498	- 0.463	
- V _{OTI} = - I ₀ R ₀₁ - I' _{0A} H ₀₁	- 0.471	- 0.521	- 0.551	- 0.553	- 0.528	
- I _{AD} R ₁ = - 0.020 I _{AD}	- 0.010	- 0.015	- 0.020	- 0.025	- 0.030	
- I' _{ADA} H ₁ = - 1.63 I' _{ADA}	- 0.347	- 0.378	- 0.395	- 0.386	- 0.362	
- 0.020 I _{AD} - 1.63 I' _{ADA} - V _{OTI}	- 0.828	- 0.914	- 0.966	- 0.964	- 0.920	
V _{XGI} = V _{AG} - 0.020 I _{AD} - 1.63 I' _{ADA} - V _{OTI}	- 0.084	- 0.122	- 0.155	- 0.162	- 0.156	
I _{BD} R ₁ = - 0.020 I _{BD}	0.005	0.008	0.010	0.012	0.016	
- I' _{BDA} H ₁ = - 1.63 I' _{BDA}	0.173	0.189	0.196	0.192	0.179	
- 0.020 I _{BD} - 1.63 I' _{BDA} - V _{OTI}	- 0.293	- 0.324	- 0.345	- 0.349	- 0.333	
V _{YGI} = V _{BG} - 0.020 I _{BD} - 1.63 I' _{BDA} - V _{OTI}	- 1.044	- 0.944	- 0.814	- 0.648	- 0.454	
V _{ZGI} = V _{CG} - 0.020 I _{CD} - 1.63 I' _{CDA} - V _{OTI}	- 0.379	- 0.591	- 0.785	- 0.945	- 1.065	
3V _{WOI} = V _{XGI} + V _{YGI} + V _{ZGI}	- 1.507	- 1.657	- 1.754	- 1.755	- 1.675	
- 2V _{WO}	1.004	1.104	1.170	1.170	1.116	
V _{R1} = V _{XGI} - 2V _{WOI}	0.920	0.982	1.015	1.008	0.960	
V _{S1} = V _{YGI} - 2V _{WOI}	- 0.040	0.160	0.356	0.522	0.662	
V _{T1} = V _{ZGI} - 2V _{WOI}	0.625	0.513	0.385	0.225	0.051	
V ¹ R ₁	X	0.062	0.033	- 0.007	- 0.048	
V ¹ S ₁	X	0.200	0.196	0.166	0.140	
V ¹ T ₁	X	- 0.112	- 0.128	- 0.160	- 0.174	
V ¹¹ R ₁ SIGN	X	X	-	-	-	
V ¹¹ S ₁ SIGN	X	X	-	-	-	
V ¹¹ T ₁ SIGN	X	X	-	-	-	
V _{R1} QD	X	X	I	II	II	
V _{S1} QD	X	X	I	I	I	
V _{T1} QD	X	X	II	II	II	
V ¹ X _{G1}	X	- 0.038	- 0.033	- 0.007	0.006	
V ¹ Y _{G1}	X	0.100	0.130	0.166	0.194	
V ¹ Z _{G1}	X	- 0.212	- 0.194	- 0.160	- 0.120	
V ¹¹ X _{G1} SIGN	X	X	+	+	+	
V ¹¹ Y _{G1} SIGN	X	X	+	+	+	
V ¹¹ Z _{G1} SIGN	X	X	+	+	+	
V _{XGI} QD	X	X	III	III	IV	
V _{YGI} QD	X	X	IV	IV	IV	
V _{ZGI} QD	X	X	III	III	III	
PH. A OPX OPERATION COUNTER	X	X	INCR.	X	INCR. (†)	
PH. B OPX OPERATION COUNTER	X	X	X	X	X	
PH. C OPX OPERATION COUNTER	X	X	X	X	X	

(†) TRIP LINE BKR. (S)

APPENDIX HFIL VOLTAGE FILTERING FOR DISTANCE ROUTINES

QD quadrant determination utilizes the sign of the first and second differences rather than the sign of the quantity and its first difference in order to minimize the effect of transients below the system frequency. The filtering routine described here attempts to eliminate the influence of higher frequencies such as in Fig. 18, where a transient is superimposed on voltage V_{AB} . Note that the filtered values are plotted.

When a quadrant changes to other than the succeeding one, FIL is called. In Table VI a jump occurs between sample 2 and 3. If sample -3 QD had been quadrant I, FIL would not have been called. The procedure is as follows:

1. When a quadrant jump occurs at sample K , average the voltages of samples $K-3$, $K-2$, and $K-1$ and replace the $(K-2)$ voltage with this average, (e.g. sample 1 average of -0.49 replaces -0.76).
2. Average voltages $K-2$ (original), $K-1$ and K , replacing the $(K-1)$ voltage with this average.
3. Perform new QD for sample $K-1$.
4. Average voltages $K-1$ (original), K and $K + 1$, replacing the K voltage with this average.

5. Perform new QD for sample K.
6. Using averaged K voltage, make QD for sample $K + 1$.

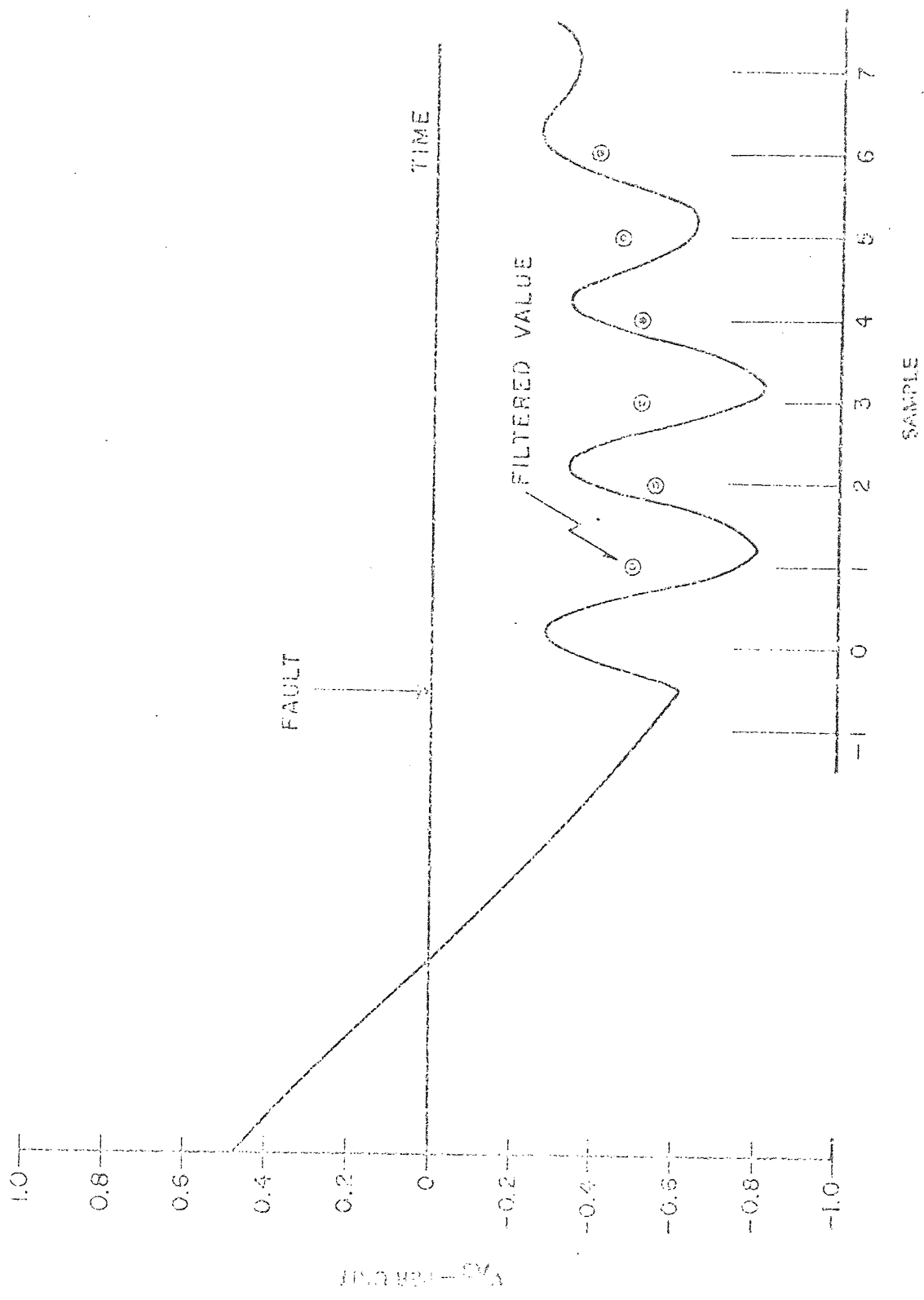

FIG. 12 EFFECT OF FILTERING

TABLE VI FILTERING ROUTINE FOR FIG. 18

QUANTITY	SAMPLE								
	-1	0	1	2	3	4	5	6	7
V_{AB}	-0.54	-0.32	-0.76	-0.38	-0.77				
V'_{AB}	X	X	-0.44	+0.38	-0.39				
V''_{AB}	X	X	X	+	-				
QD	X	X	X	IV	II				
FILTERING RTN:		(K-3)	(K-2)	(K-1)	(K)				
V_{AB}			-0.49	-0.64	-0.51	-0.39	-0.63	-0.29	
V'_{AB}			-0.17	-0.15	+0.13	+0.12	-0.24	+0.34	
V''_{AB}			X	+	+	-	-	+	
QD			X	III	IV	I	II	IV	
FILTERING RTN:					(K-3)	(K-2)	(K-1)	(K)	
V_{AB}						-0.51	-0.44	-0.42	-0.35
V'_{AB}						0	+0.07	+0.02	+0.07
V''_{AB}						-	+	-	+
QD						I	IV	I	IV
FILTERING RTN:						(K-3)	(K-2)	(K-1)	(K)
V_{AB}							-0.46	-0.40	
V'_{AB}							+0.05	+0.06	
V''_{AB}							+	+	
QD							IV	IV	
FINAL QD				III	IV	I	IV	IV	IV

Note in the above that the "original" value may mean a filtered value from a previous pass as is the case at sample 5 in Table VI where the averaged value of -0.44 results from use of the filtered value of -0.39 in sample 4.

Except for sample 4 the filtering logic has successfully determined the quadrant position of the steady-state voltage. See the last row of Table VI.

APPENDIX ICPD LINE-CURRENT PEAK DETERMINATION

CPD processes each line-breaker current each sample per Fig. 19. Block A computes the first difference. Upon a sign change of the first difference (B), the value of the sample is recorded as the peak (C) along with the time position. Two peaks are stored so that Z3PH may compare the pre- and post-fault values to confirm that VFD saw a fault.

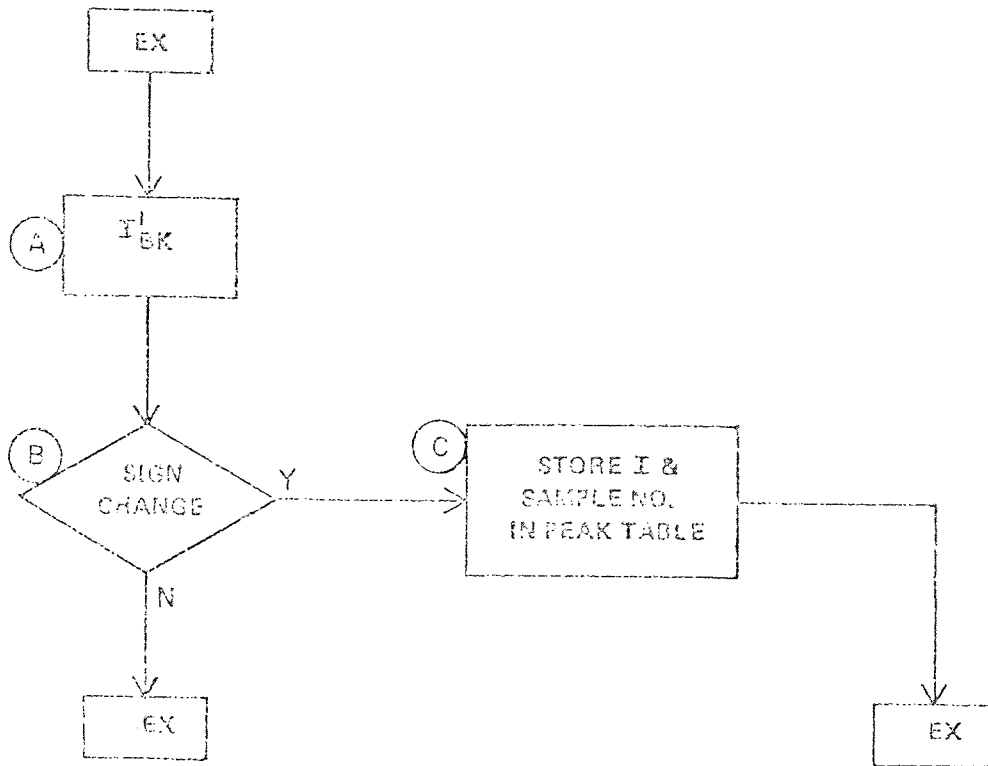

FIG. 19

CPD CURRENT PEAK DETERMINATION FOR LINE CURRENTS

APPENDIX JVFD VOLTAGE FAULT DETECTOR

VFD processes each voltage sample as shown in Fig. 20. Block A looks for a significant jump in $3V_0$ since the last sample. Block A makes one such check per voltage level (three in Fig. 1) unless a fault is indicated sooner. Then, block B looks for a sign change or a zero value in the first difference of the phase to ground voltage (one check for each of three voltages on each voltage level, unless a fault is detected sooner). Block E stores the measured value as the peak. If this value is at least $1/64$ p.u. less than the previous peak a fault is detected.

Either A or F enters bids (C) for selected fault routines as well as a 16 ms delayed bid for TOP. VFD then removes its own priority. VFD will not turn on until TOP turns off the fault routines. This will occur in 16 ms unless at least one of the differential or line routines finds some indication of a fault.

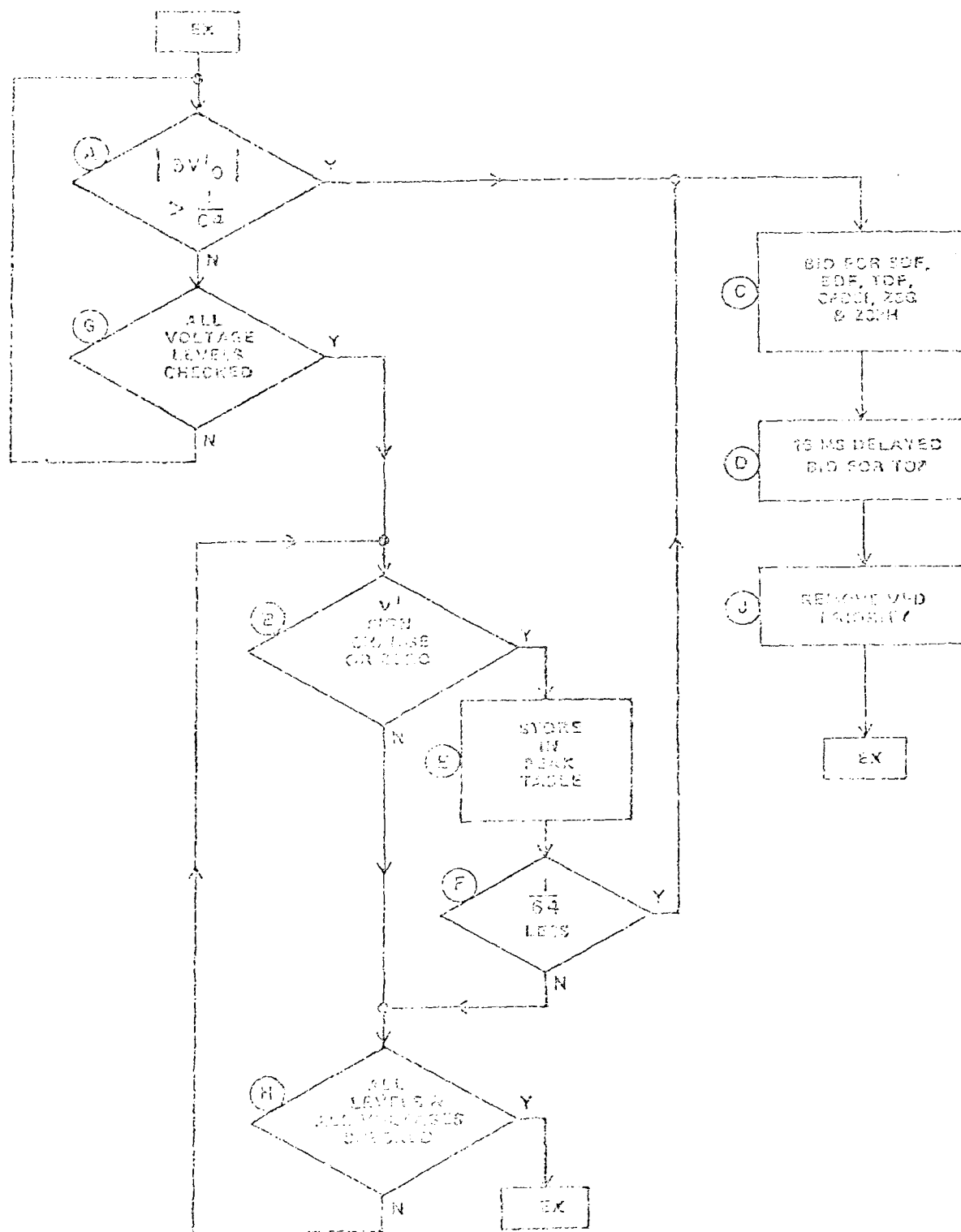

FIG. 10

VFD VOLTAGE FAULT DETECTOR

APPENDIX K

SDF STATION OVERALL DIFFERENTIAL

Refer to Fig. 21. Block A sums the line currents. To handle the phase shift in wye-delta power transformers, delta currents or phase currents less zero-sequence current must be used. If in Fig. 1 the 500 kv and 230 kv phases are identified A-B-C, while the 66 kv phases are identified 1-2-3, the three line-current summations would involve:

$$I_A - I_C \text{ with } I_1 - I_0 \qquad \text{Phase A}$$

$$I_B - I_A \text{ with } I_2 - I_0 \qquad \text{Phase B}$$

$$I_C - I_B \text{ with } I_3 - I_0 \qquad \text{Phase C}$$

Note that these computations exclude zero-sequence current. This avoids false operation during ground faults external to the station due to current flow in the power transformer grounds, which is not measured.

Block B calculates the Phase A first difference; if it exceeds 0.05 p.u., block C sums the magnitudes of the line currents for use by PDFC (block D). If B answers no, phase B line currents are summed. If any of the phases sees a fault (E, G or H), block F removes the SDF priority (also see Table II) and advances BDF and TDF priorities. EX then checks all bids, calling the lowest numbered priority being bid.

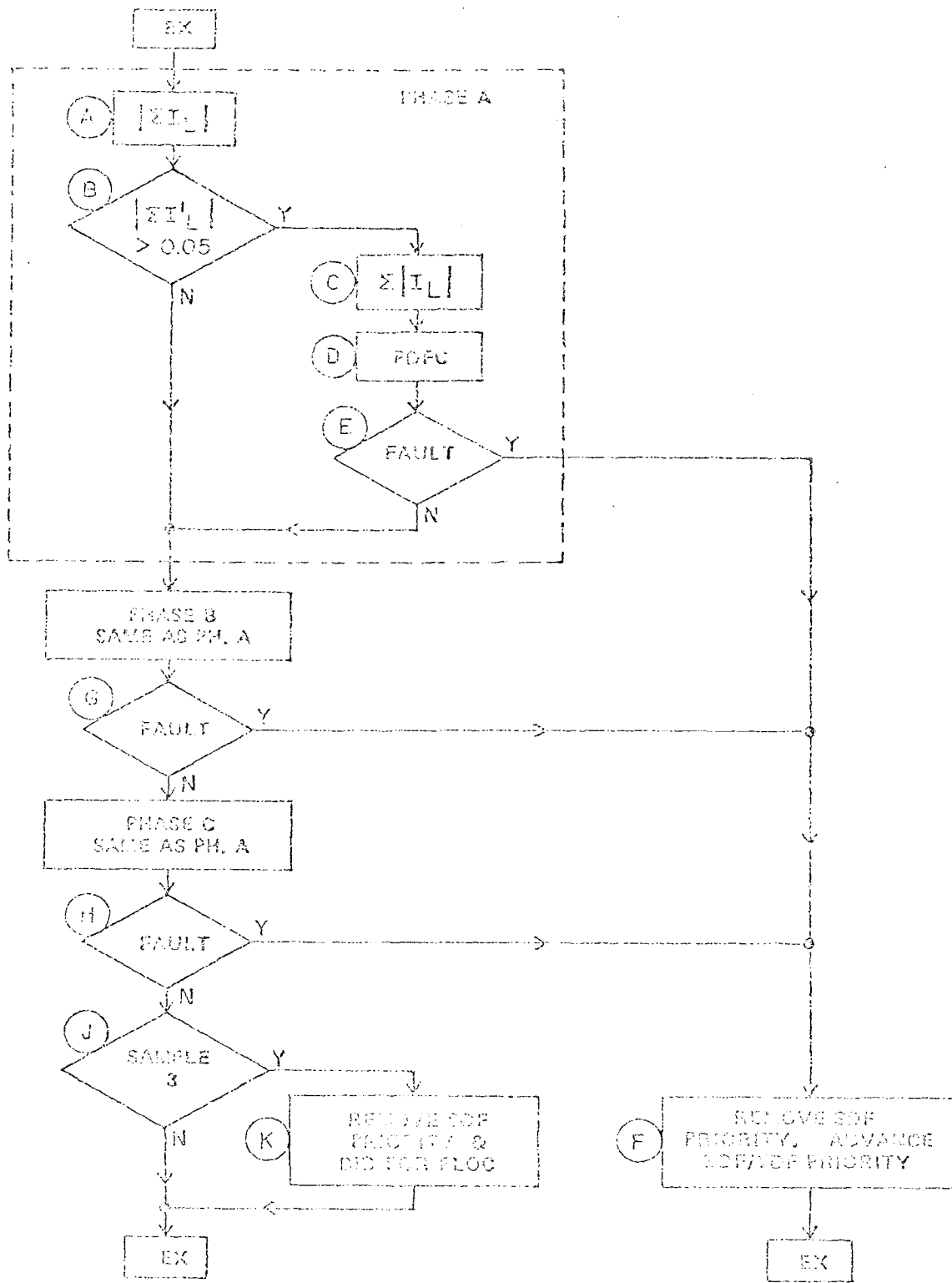
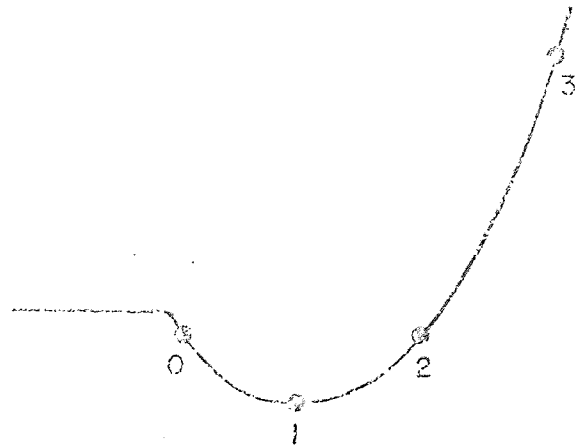
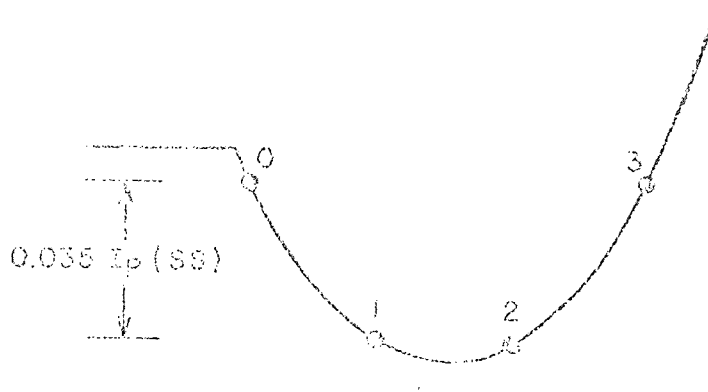

FIG. 21 SDF STATION OVERALL DIFFERENTIAL



(a)

SAMPLE 0 AND 2 STRADDLE PEAK



(b)

SAMPLE 1 AND 2 STRADDLE PEAK

After four unsuccessful passes block J removes the SDF priority and enters a FLOC bid. SDF requires a minimum of two samples since block B requires a first difference which is not available until sample 1 (SDF begins computation with sample 0). If samples 0 and 2 straddle the peak per Fig. 22(a), samples 1 and 2 detect very small first differences; accordingly, SDF may continue to sample 3 if needed. Fig. 22(b) represents the limiting case for a minimum first difference for samples 1 to 3. For this case SDF detects a minimum differential current of:

$$I_p (ss) = \frac{0.05}{0.035} = 1.4 \text{ pu}$$

APPENDIX L

FLOC LINE-FAULT LOCATOR

Fig. 23 indicates how FLOC tries to pinpoint which line is faulted to expedite tripping. If VFD found sufficient $|3V'_0|$, block A answers yes. Block B decides which voltage level is faulted, while C looks at all $3I_0$ currents on that level since the faulted line usually carries the highest current. Block D advances the zone 3 priorities on that line to 5, giving this line precedence over the other lines which have a priority of 8 and over the differential zones with a priority of 9.

If VFD called FLOC due to a phase-to-ground voltage drop, A answers no. Then, E searches for the highest line-current first-difference magnitude. If it exceeds 0.35 pu indicating a fault current greater than load current, the zone 3 priorities are advanced on that line (H). Maximum first difference occurs for samples which straddle zero:

$$|I'| \text{ (max)} = (2 \sin 5.4^\circ) I_p \text{ (ss)} = 0.19 I_p \text{ (ss)}$$

FLOC will not operate for a load current less than:

$$I_p \text{ (ss)} = \frac{0.35}{0.19} = 1.8 \text{ pu}$$

Block G sets a flag for use by Z3PH. Block I limits FLOC to the first 4 samples. For the most unfavorable fault inception angle per Fig. 22 and App. K there may only be $0.035 I_p \text{ (ss)}$. Thus, block F may require fault current as high as:

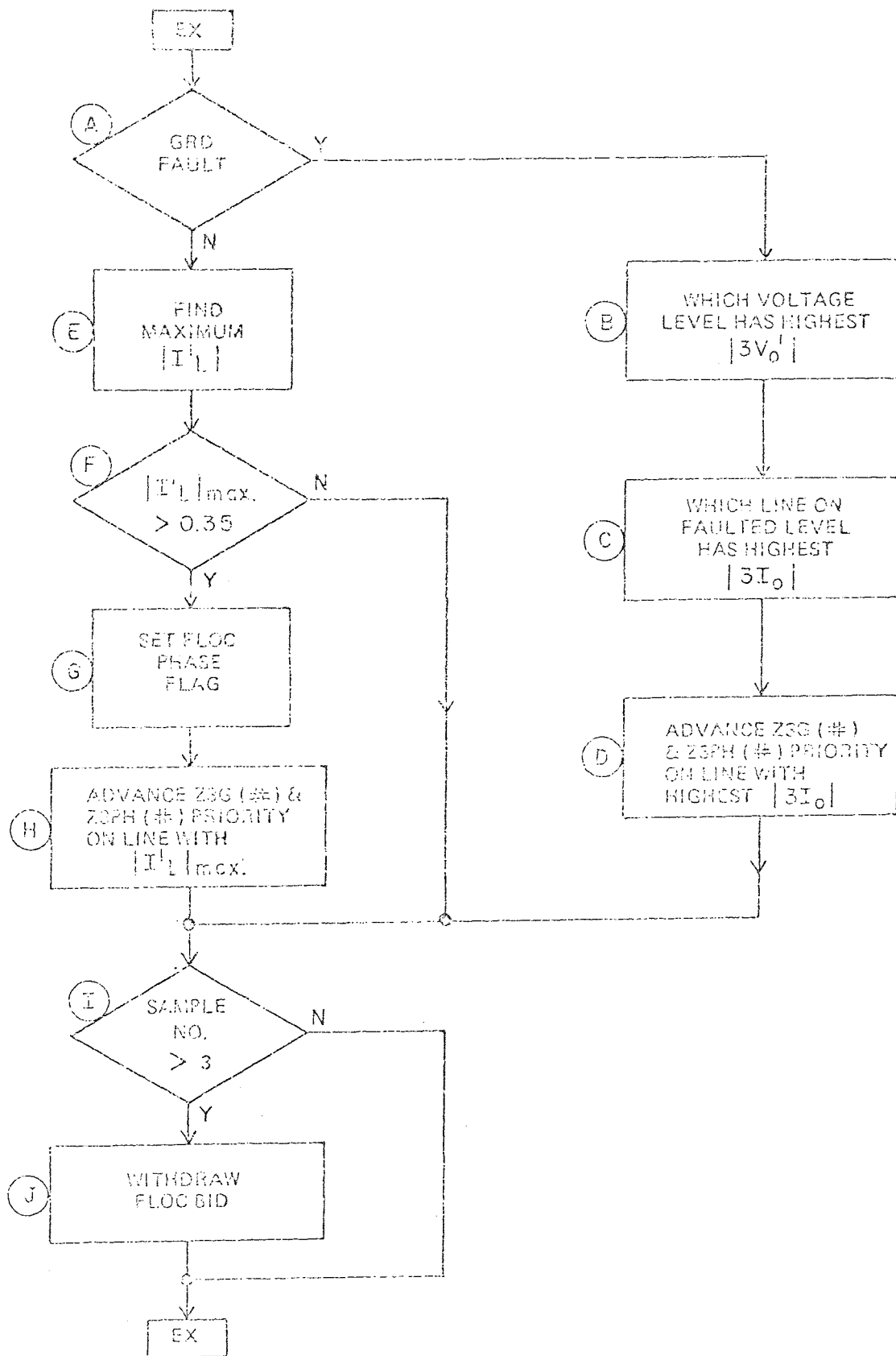

FIG. 23

FLOC LINE-FAULT LOCATOR

$$I_p(ss) = \frac{0.35}{0.035} = 10 \text{ pu.}$$

Where FLOC cannot narrow the search, the zone 3 routines are called in arbitrary order.

APPENDIX MBDF BUS DIFFERENTIAL

See Fig. 24 which applies for one phase. Block A sums the phase currents connecting to the bus and looks for a magnitude exceeding 0.25 pu. If the differential current is too small, block B checks for a first-difference magnitude exceeding 0.05 pu. A yes from either A or B permits H and J to perform a percentage-differential check per Fig. 7. If J detects a fault, block K increments operation-counter C1. If the counter now reads more than 1, block L calls TRIP and BF. All breakers surrounding the bus are tripped. BF watches to see that all are successfully tripped.

If block L answers no, indicating this is the first successful pass, M advances the priority of this BDF (#) phase. If the WS flag is set (P) showing that the wave shape is satisfactory, the program returns to EX for a bid check. If P answers no and the routine is processing one of the first four samples (R), no WS call is needed, since the CT's have not yet saturated.

If block R answers yes, S clears counter C1 while T suspends BDF(#) and enters a suspended bid for WS. When CPDSI detects the next peak of the associated differential current it will allow a WS call. If WS finds a satisfactory wave shape it in turn removes the BDF(#) suspension. BDF(#) starts over since S cleared counter C1.

Tripping requires two successive positive passes, since block C clears operation-counter C1 on each negative pass. Blocks D and

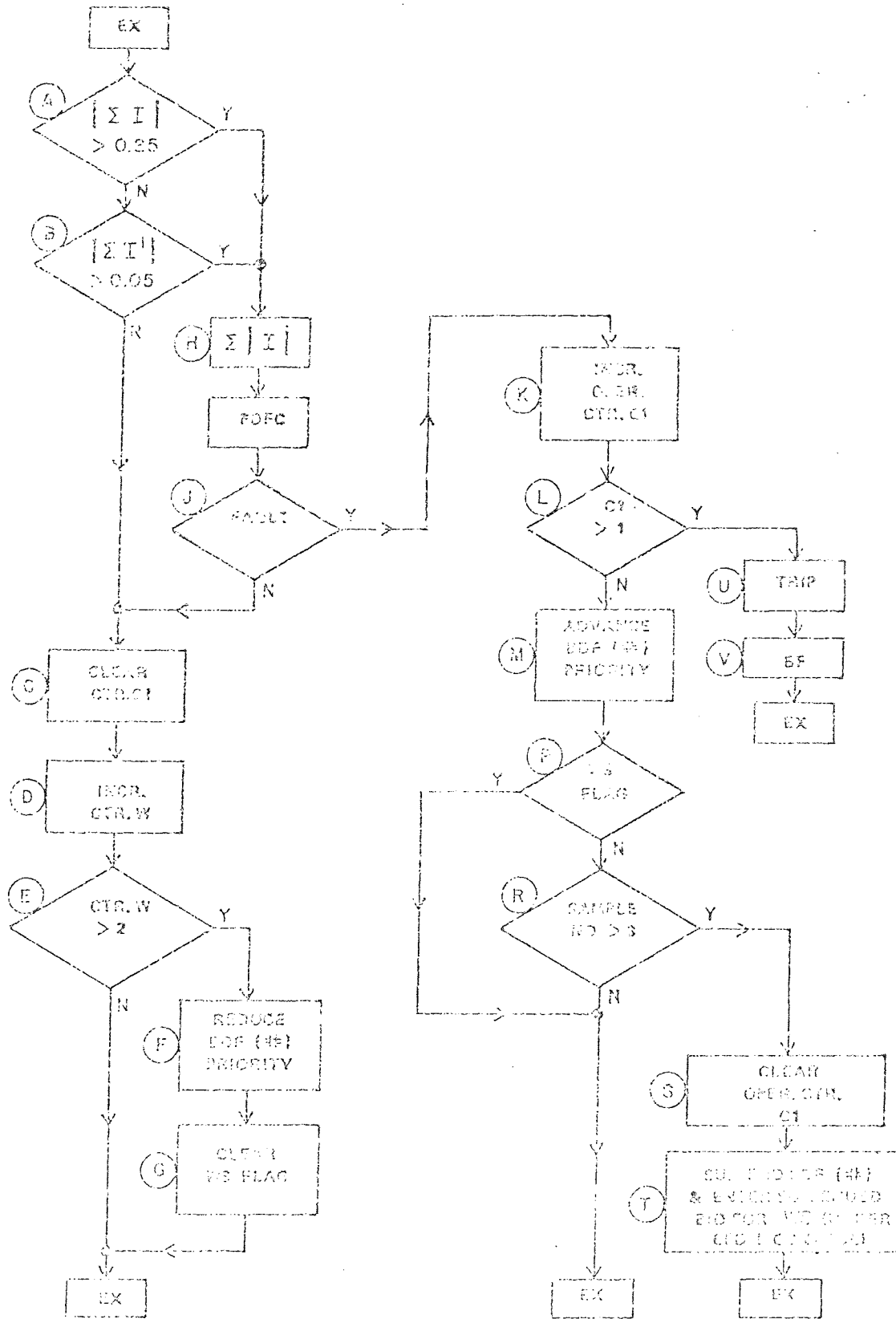

FIG. 24 BOP BUS DIFFERENTIAL

E provide a means to reduce a BDF($\#$) priority (F) if no fault is found after three negative passes. If time permits another try is made; block G requires another WS call on a subsequent BDF($\#$) call.

APPENDIX NTDF TRANSFORMER DIFFERENTIAL

Blocks in Fig. 25 with letters identical to those in Fig. 24 have identical logic, except the currents connecting to the power transformers are summed. On the delta-winding side of a wye-delta transformer (e.g. TR2, Fig. 1) the phase current is compared with the "delta" (difference of two phases) current. Assuming that the delta winding is on the higher voltage side the current summations are:

<u>Phase</u>	<u>Delta Side</u>	<u>Wye Side</u>
A	I_A	$I_1 - I_2$
B	I_B	$I_2 - I_3$
C	I_C	$I_3 - I_1$

With an autotransformer (e.g. TR1 in Fig. 1) delta currents are compared to eliminate zero-sequence current.

TDF uses the added blocks Q and X. EX, as well as VFD, can call TDF. If EX makes a periodic call, Q requires that T bids for WS. This is needed since the program must assume the possibility of dc CT saturation or that magnetizing inrush current is flowing for an EX call.

Even for a VFD call and for the first four samples, block X requires a WS check (T) if switching has occurred in the last 32 ms since VFD might operate at the time of switching a fault; moreover, this switching could subject power transformers to initial recovery magnetizing-inrush conditions. Switching means:

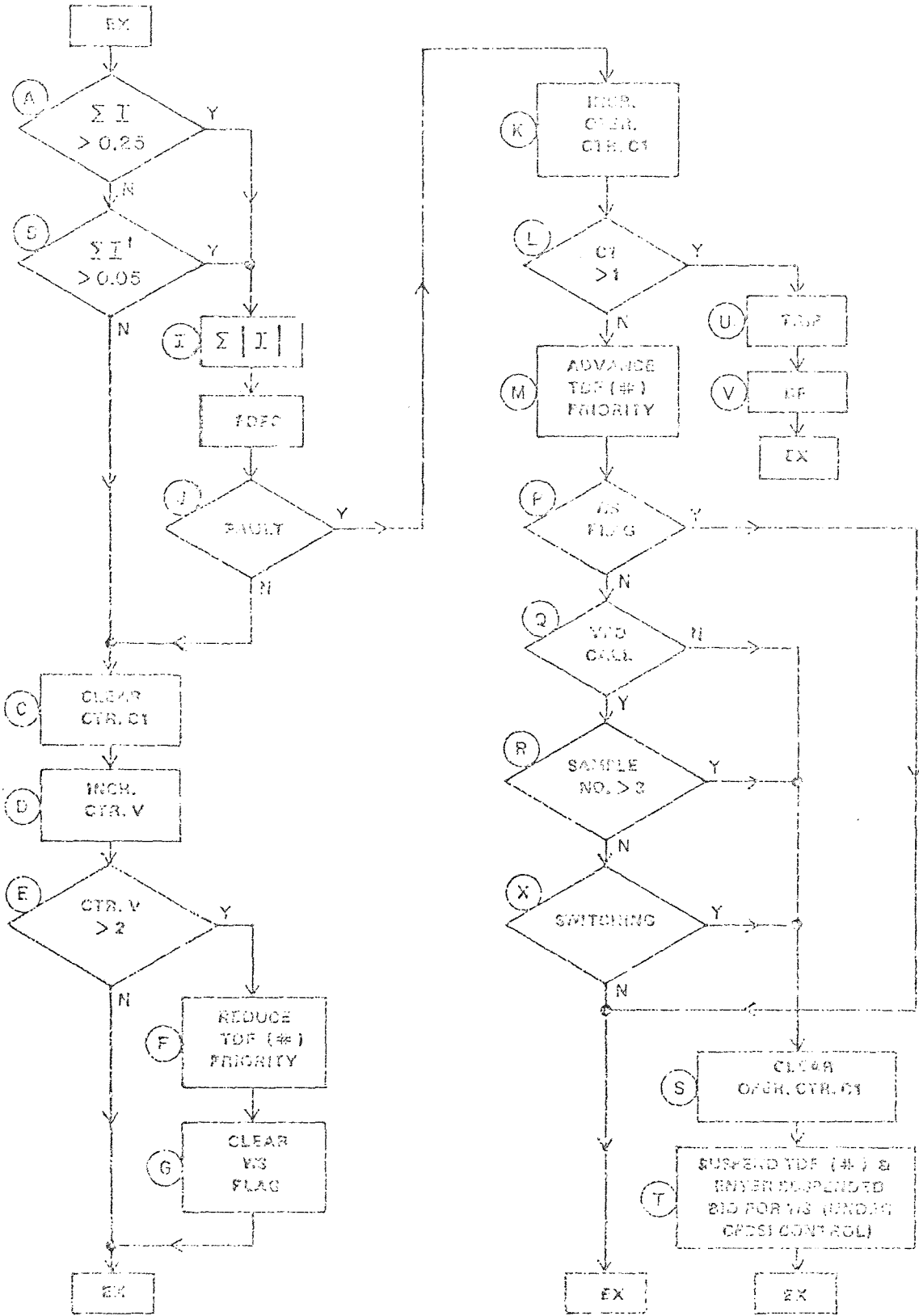

FIG. 25. TDF TRANSFORMER DIFFERENTIAL.

- a. Any breaker opening or closing in station
- b. Any disconnect switch closing in station
- c. Trip initiation by the program.

Part (c) obviates any possible problem due to late operation of the breaker auxiliary switch (position indication).

APPENDIX OCPDSI DIFFERENTIAL CURRENT PEAK DETERMINATION

See Fig. 26. Block A computes the delta current for wye-delta transformer (TR2, Fig. 1) zones. Blocks B and C determine the differential current magnitude and first difference, respectively. If D detects a sign change in the first difference, its value and time position are stored (E) for WS use. Blocks G, H and J form an instantaneous trip logic, by summing the present and previous peak magnitudes. By summing two peaks most of the dc component effect due to a fault or magnetizing inrush cancels out.

Block J requires that the two peaks must be at least 15 samples apart to avoid operation due to an offset peak with a superimposed high frequency transient. If G, H and J initiate instantaneous tripping (K), WS(#) bids for that zone are withdrawn (M).

CPDSI checks all differential current first differences every sample upon VFD operation.

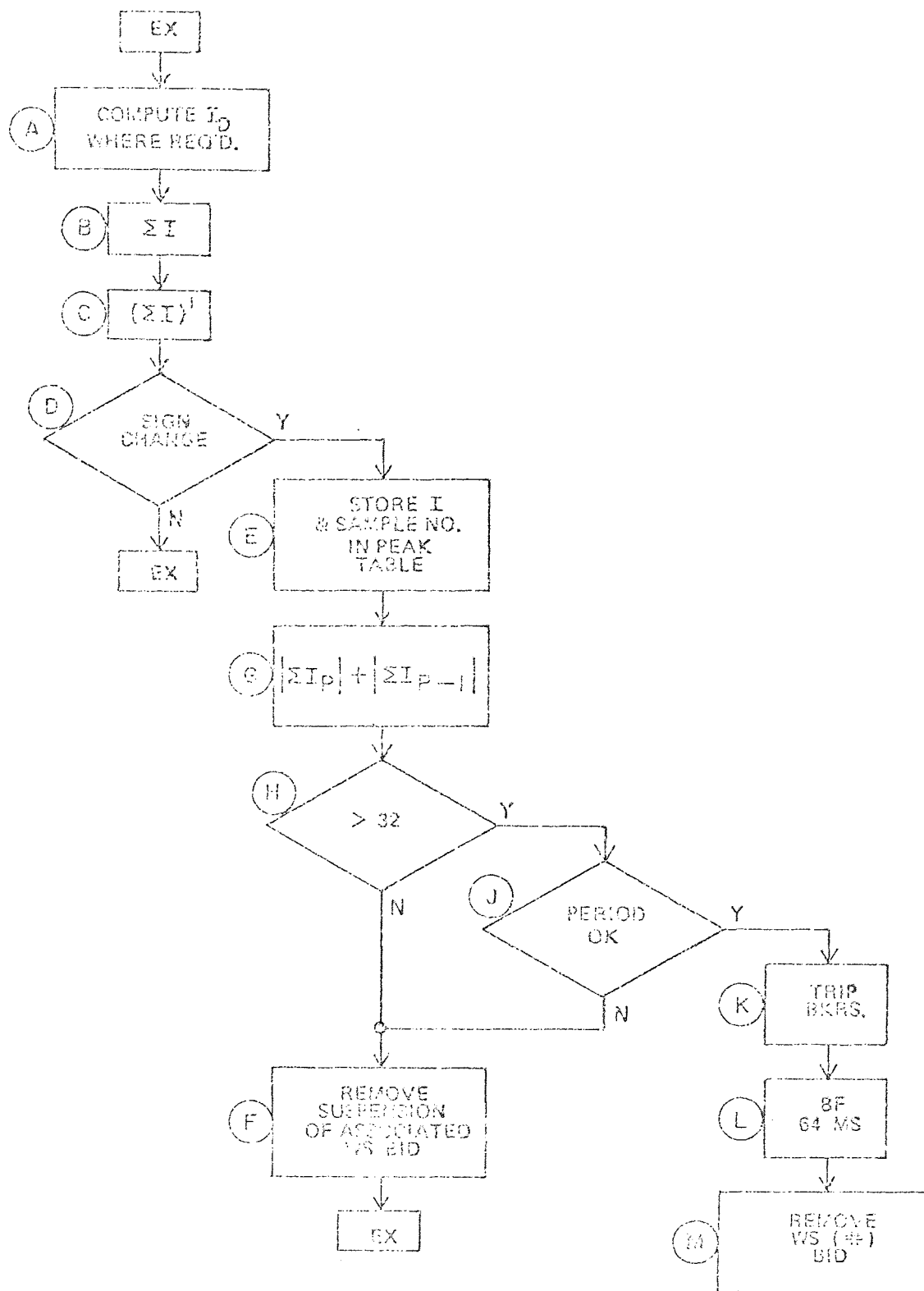

FIG. 25 CPDSI DIFFERENTIAL-CURRENT PEAK DETERMINATION

APPENDIX PWS WAVE-SHAPE ANALYSIS

When CPDSI senses a peak, WS in Fig. 27 checks to see if it occurred 15-20 samples since the last peak, is opposite in sign, and 75 to 125% of the magnitude of the last peak. If so, the BDF(#) or TDF(#) bid suspension is removed. If the wave shape is not satisfactory WS enters a suspended bid for its program, so it can check the next peak.

Generally, WS will not be successful on its first call since it requires two peaks subsequent to the fault.

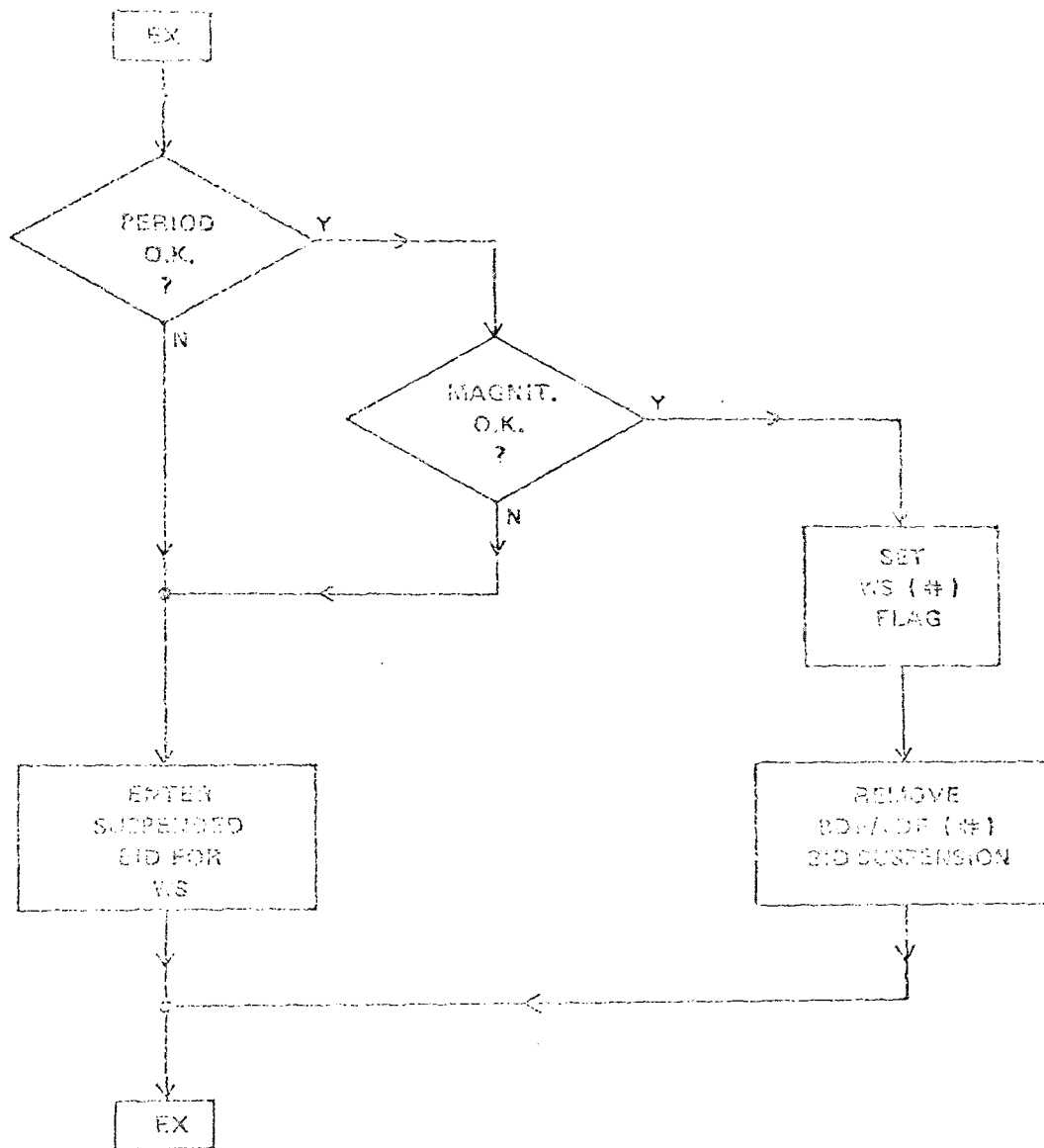

FIG. 27

V.S. WAVE SHAPE ANALYSIS

APPENDIX QZ3G AND Z3PH ZONE 3 DISTANCE

Fig. 28 and 29 form an integral routine since EX cannot call Z3G and Z3PH separately. Some of the computations (see App. E) are common to the ground- and phase-fault routines, so they have been tied together. The routines begin at block A of Fig. 28. Z3GS-OPX angle comparison may yield a positive fault indication (yes in block A), a negative indication (yes in block K) or an indeterminate result (no in block K). If the phase A comparison fails to indicate a fault, phase B (M) and, if needed, phase C (P) angle comparisons are made. If results are still negative, the program proceeds to Z3PH.

Each time a definite no-operation occurs, block L of Fig. 28 decrements the phase A operation counter in accordance with OPX requirements discussed in section V. Note that the operation counter limits are 0 to 3. Block L also increments the priority counter; after all five of these counters (block V of Fig. 29) reach 3, this line's zone 3 priority is reduced to allow more time to look elsewhere for the fault.

The first time block A of Fig. 28 answers yes, block B will answer no, requiring a residual-current first-difference check (block C). This block prevents tripping for potential circuit trouble which severely affects the angle and magnitude of the input potential. The program cannot reach block C until sample 4 so block C examines as many of the first five samples as are needed. If none exceed 0.06 pu, Z3PH

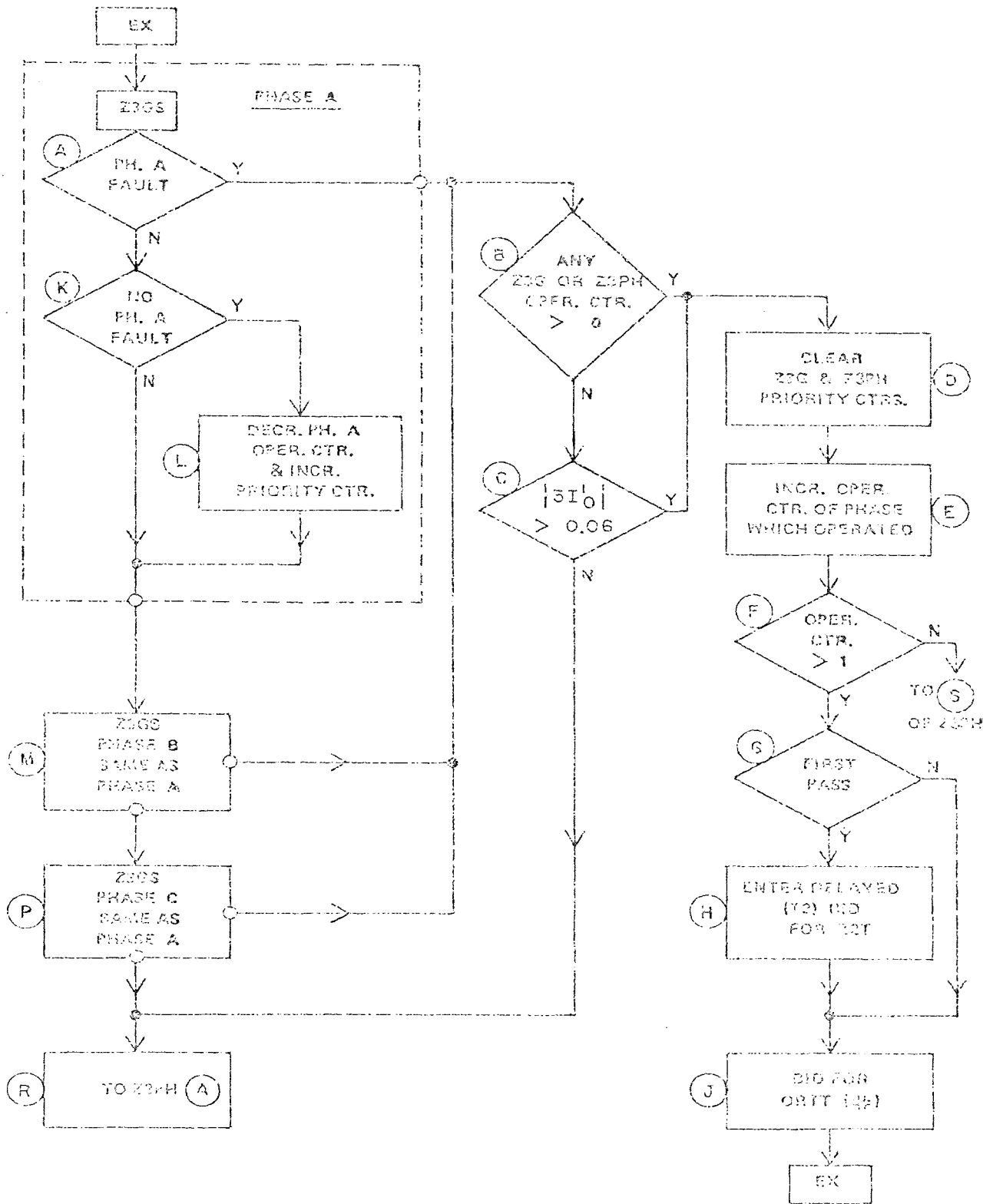

FIG. 23

ZSG ZONE 3 GROUND DISTANCE

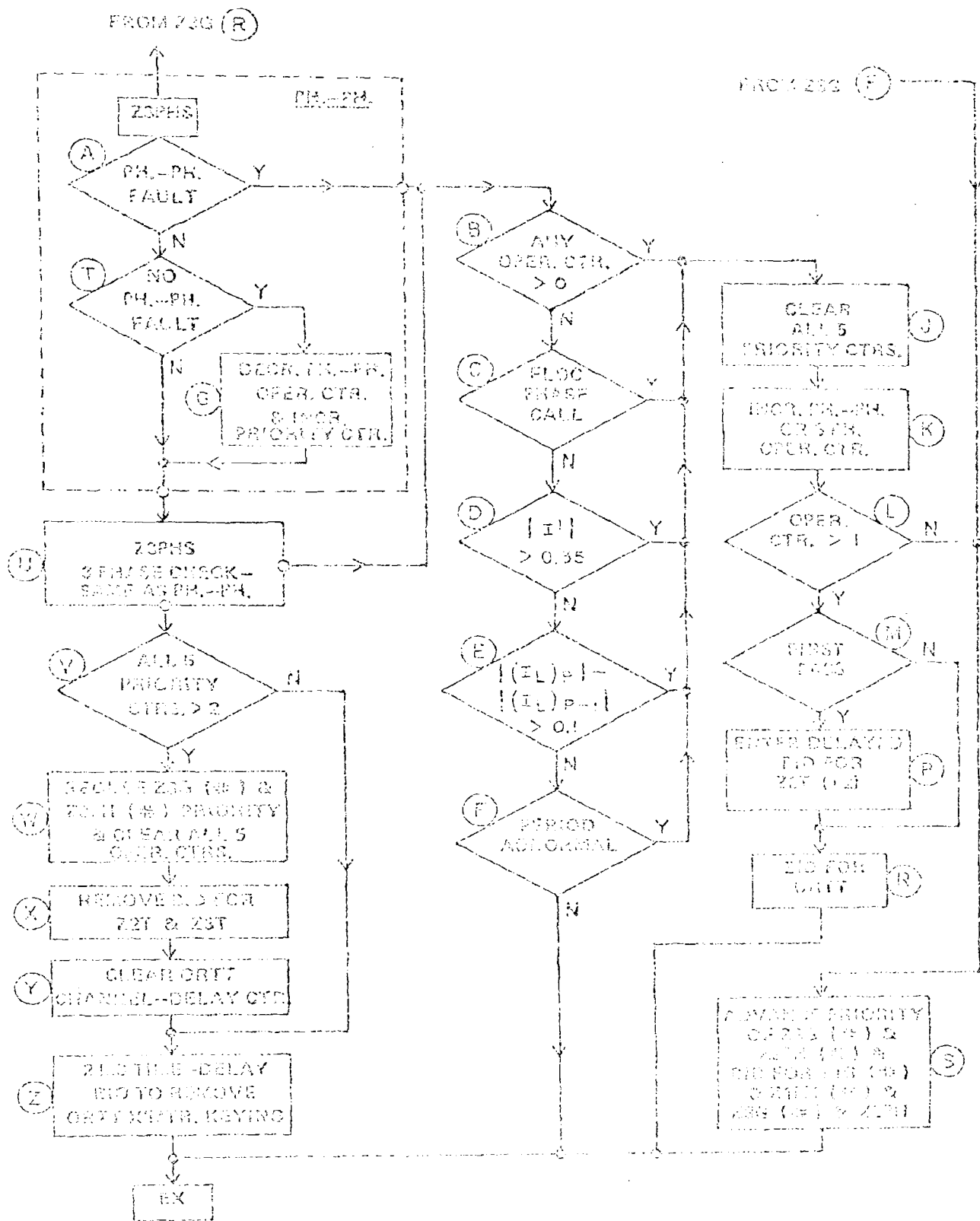

FIG. 23

ZONE 0 CHANGE DISTANCE

performs its angle comparisons in Fig. 29. Each time block C gets the opportunity it checks all new samples since the last check; if necessary, it will wait for the maximum first difference of $0.188 I_p(ss)$, corresponding to a sensitivity of $I_p(ss) = \frac{0.06}{0.188} = 0.3A$.

After block C in Fig. 28 detects a fault, block D clears all five priority counters and E increments the appropriate operation counter. If this counter reads one (F), block S in Fig. 29 advances this line's zone 3 priority and bids for zones 1 and 3. If any operation counter reads 2 or more (F of Fig. 28) and this is the first pass (C), block H enters a bid for Z2T to provide for tripping in time T2 (see Fig. 4) if not cleared earlier. Block J enters a bid for ORTT(#), which provides for fast tripping if the transfer-trip channel is operative.

If Z3G fails to find a fault, Z3PH (Fig. 29) angle comparisons (A and U) are made. If either check indicates a fault and B, C, D, E or F answers yes, blocks J through S function as described for Z3G. If block B answers no and if FLOC has not found a fault (C), block D looks at all post-fault samples of all three phases. If block D fails, E checks for a difference in the magnitude of the last two peaks of all three phases. Also block F answers yes if the peaks on each phase are not 15 to 20 samples apart.

Block V in Fig. 29 provides the logic ample time to find a fault and then permits block W to reduce the zone 3 priority on this line. Blocks W, X and Y reset various items which might have been initiated on earlier passes. Block Z provides for a 2 ms delay in removing

transfer-trip keying to allow for continuous keying even though the angle comparisons fail to yield a fault indication on every sample for an internal fault.

APPENDIX RZ1 ZONE 1 DISTANCE

Z3G/Z3PH(#) bids for Z1. The computations are similar to those for zone 3 (see App. E and G). While Fig. 30 shows only two angle comparisons (A and F) for simplicity, there are three ground and two phase checks, any one of which connect to block M. When any of the five zone 1 operation counters reads 2 or more (counter range is 0-3) tripping occurs (R), a time-delay BF bid is entered (S) and the transfer-trip transmitter is keyed (T) in case zone 3 did not have time to do it. Blocks U and L withdraw zone-3(#) and zone-1(#) bids.

Each time a definite operation occurs, block E or J increments its priority counter; when block K finds all five counters reading 3 or more it withdraws the Z1(#) bid.

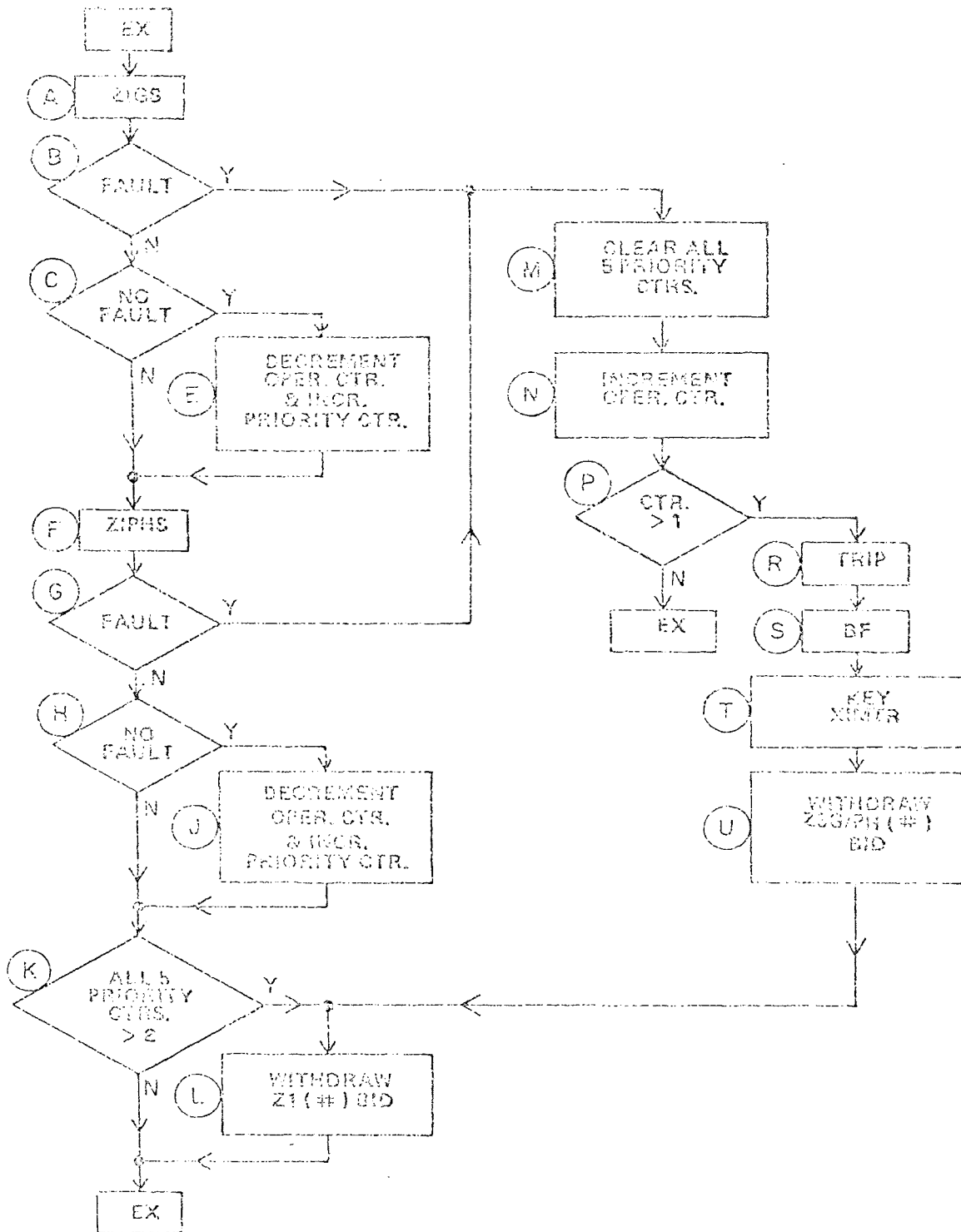

FIG. 39 Z1 ZONE 1 DISTANCE

APPENDIX SZ2T ZONE 2 TIME-DELAY TRIP

If Z3G/Z3PH continues to operate until time T2 has elapsed, EX calls Z2T. As outlined in App. E, Z2GS (A) and Z2PHS (E) consist of five angle comparisons (3 ground and 2 phase). Fig. 4 shows their reach extending beyond station R, providing back up for the pilot system (ORTT). Calculations begin with sample t-8, ignoring the two oldest samples to insure that computations are finished before needed data is lost from buffer storage.

As with the other distance tripping, block R in Fig. 31 requires two yes outputs from either block B or F with no intervening positive non-operation from block C or G. If zone 2 cannot find a fault, block K enters a delayed bid for Z3T. EX allows Z2T 16 samples to locate the fault. If it fails, block L enters a delayed bid for Z2T on the basis that system conditions might change to allow zone 2 to see the fault. Otherwise, clearing must await the elapse of T3-T2 time (e.g. 1 s).

Block U withdraws zones 2 and 3 bids when tripping is initiated (S).

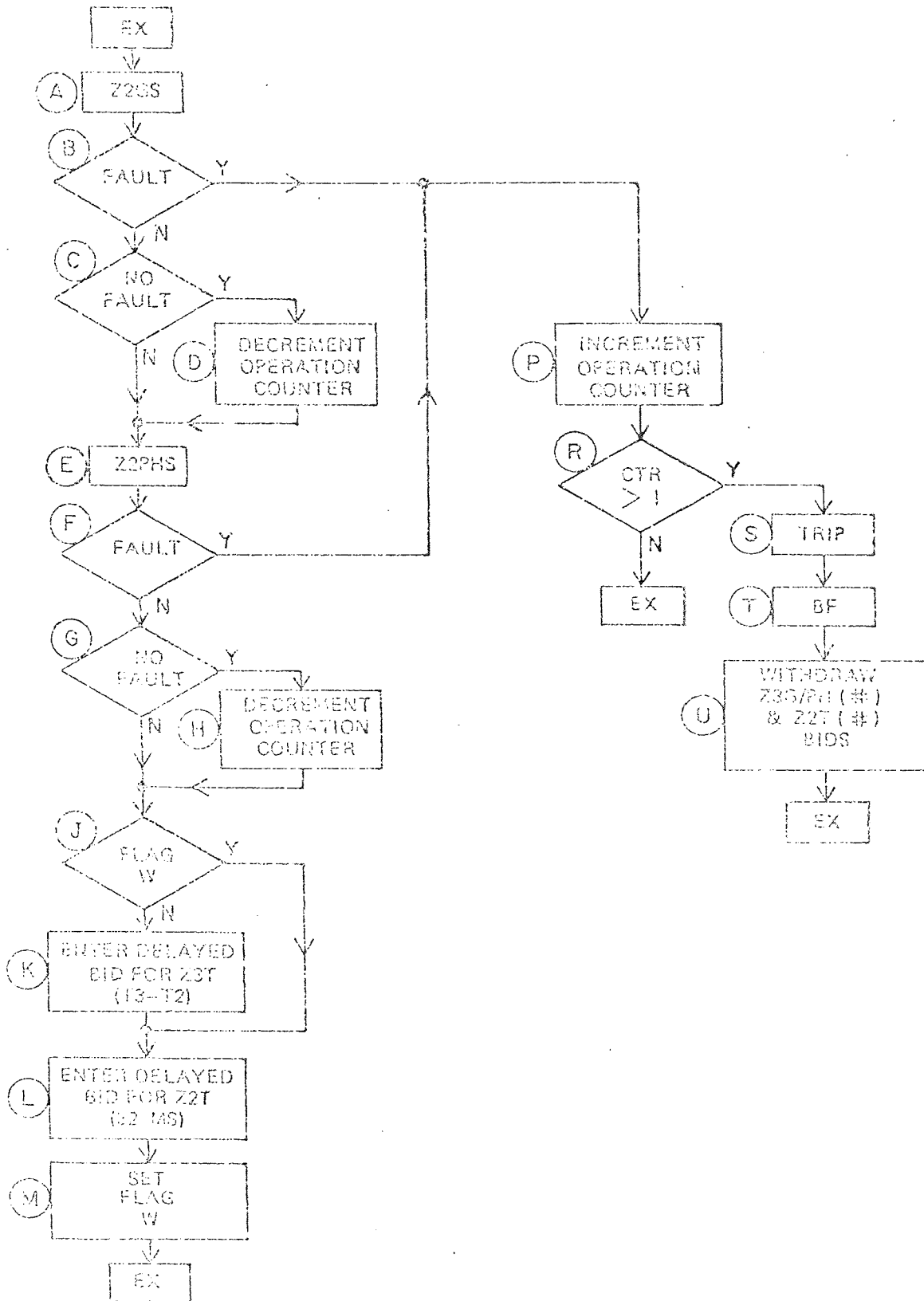

FIG. 31 Z/T ZONE 2 TIME-DELAY TRIP

APPENDIX TZ3T ZONE 3 TIME-DELAY TRIP

If the fault persists until T3 time has elapsed, as indicated by continued operation of Z3G/Z3PH, the line breaker(s) is tripped and a time-delay bid entered for BF. ORTT contains logic for a periodic check on zone 3 operation (block J, Fig. 33) to make some time available for non-fault programs.

APPENDIX UMA MEMORY ACTION

MA checks each sample for a low magnitude of V_{AB} (A) in Fig. 32. If V_{AB} and its first difference (B) are both low in magnitude, indicating a nearby short circuit involving phases A and B, no quadrant determination can occur. Instead, the 3 phase angle-comparison logic would use the appropriate stored value of the V_{AB} quadrant determination. This would be the one determined 33 samples previously, or an integral multiple of 33. Block G limits this memory access time to 32 ms, since the memory can rapidly drift out of synchronism with the generated voltage, depending upon frequency. This interval is ample to allow zone 1 operation on the faulted line.

After 128 successive quadrant determinations, block E clears the trip blocking (G). Block H requires that these determinations be successive so the program can insure that all 33 stored values have been properly updated before any may be used. A counter setting of 128 (E) allows time for fault clearing transients to subside.

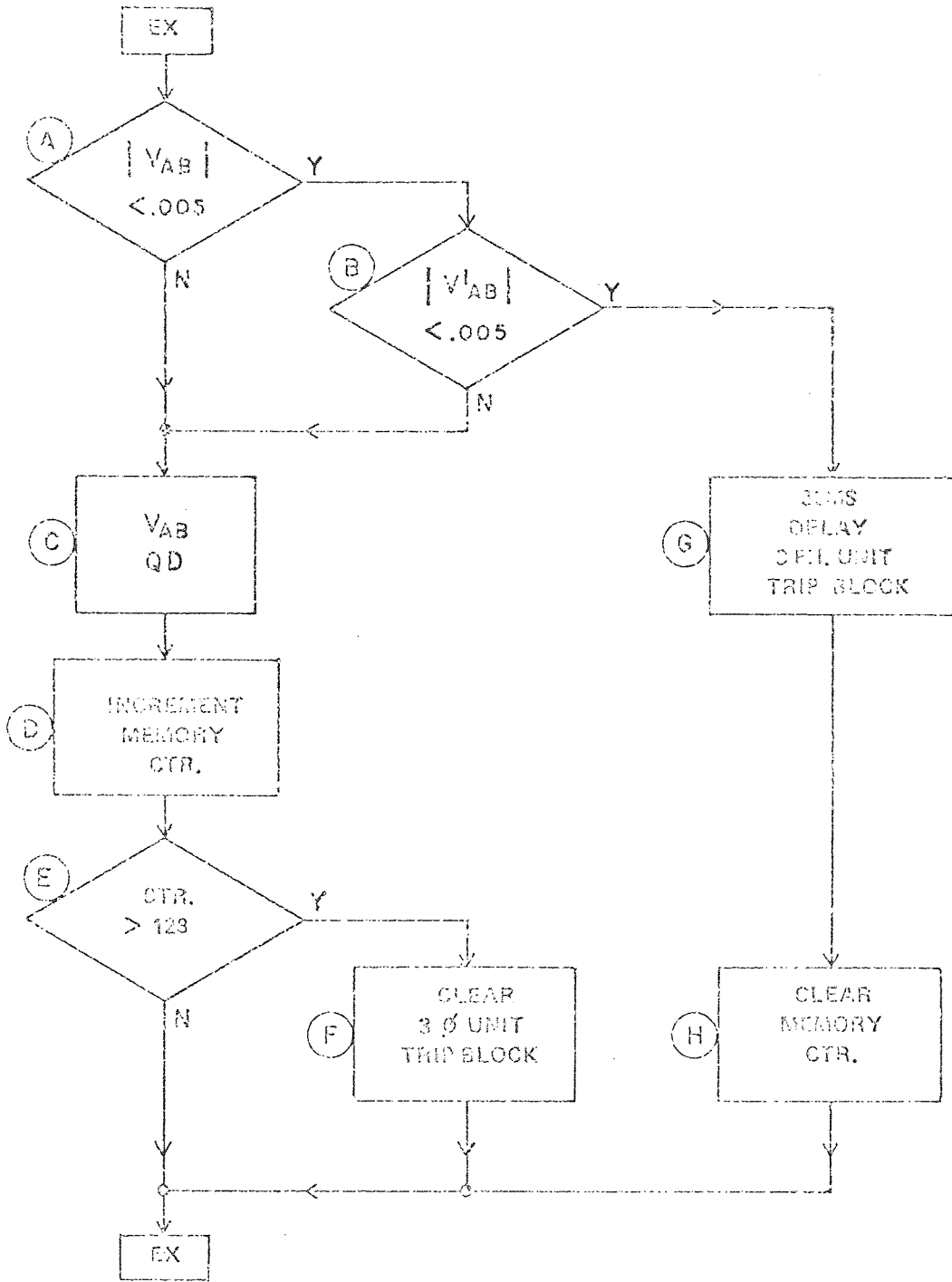

FIG. 32

SA MEMORY ACTION

APPENDIX VORTT OVERREACHING TRANSFER TRIP

Z3PH enters an ORTT bid. Fig. 33 shows this logic for pilot tripping in conjunction with a transfer-trip channel from the remote station(s). Block B initiates transmitter keying to allow fast remote breaker tripping. This block also removes a transmitter turn-off bid which may have been entered by block Z of Fig. 29 on a previous unsuccessful bid. The channel-delay counter (C and D) allows time for zone 3 and channel drop out if the direction of fault power flow reverses due to sequential breaker operation on a faulted parallel line. The counter setting in D should be at least channel drop-out time plus 4 ms, allowing for the 2 ms delay in block Z, Fig. 29 and for computation of post-reversal samples.

After the coordinating delay (D) if a transfer-trip signal is being received (E) the line breaker(s) is tripped (F) and a time-delay BF bid is entered (G). If the fault is not in the immediate line section (between stations P and R in Fig. 4), no signal will be received from the remote station(s), so block H removes local transmitter keying. Block J then provides for temporary turn off of the zone 3 routines to allow time for non-fault programs to run. When EX calls Z3G/PH(#) and TOP after 16 ms, Z3G/PH(#) has a 3 priority, while TOP has a 4 priority. If zone 3 no longer sees a fault it reduces its priority to 10, so TOP can turn off all the fault programs. If zone 3 still sees a fault, block J of Fig. 32 again enters a 16 ms time-delay bid. The cycle continues until the faulted is cleared.

Block A of Fig. 33 bypasses much of the logic for a time-delay call. If an internal fault occurs subsequent to the external fault, block K allows immediate tripping.

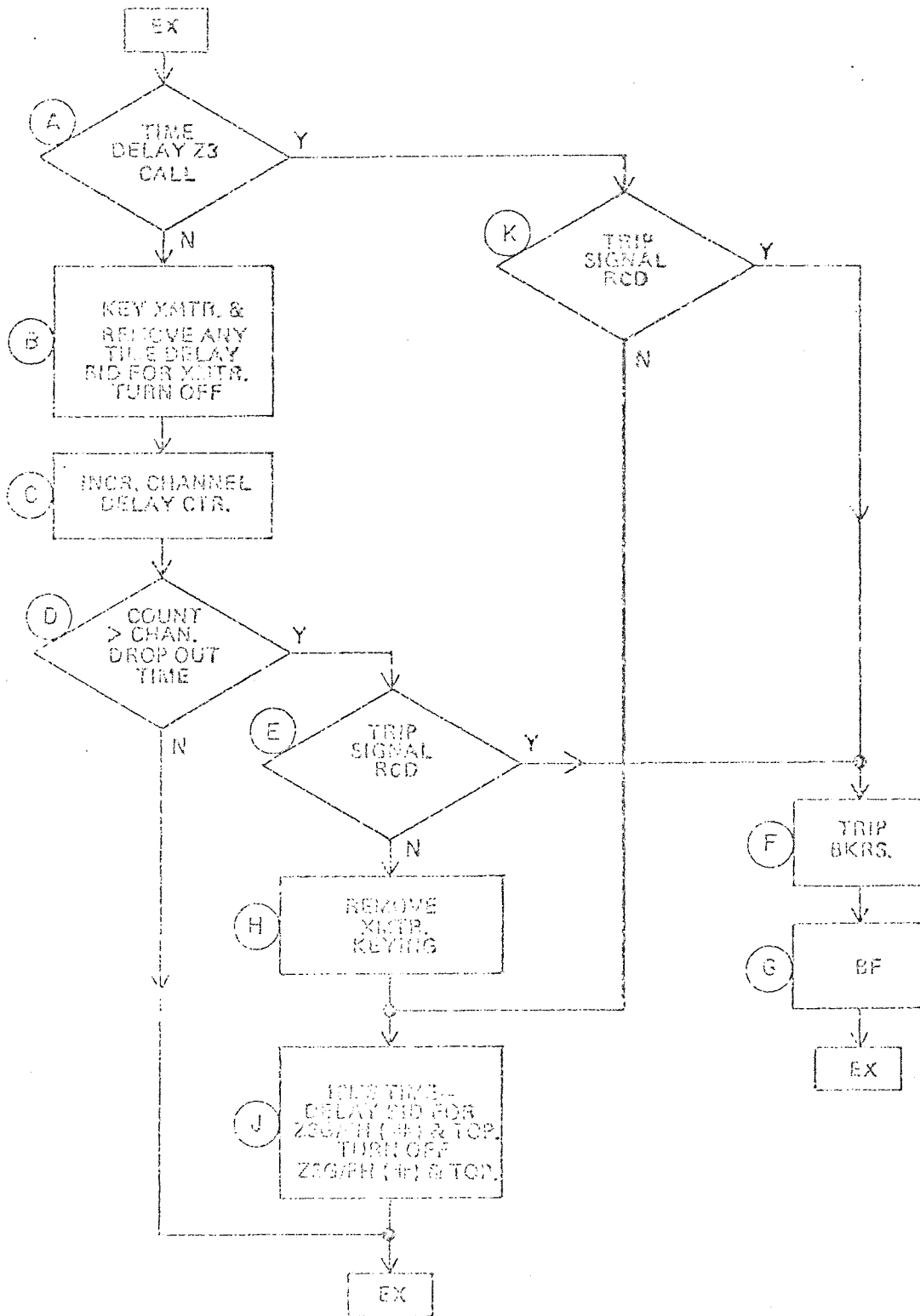

FIG. 33

ORTT PILOT LOGIC

APPENDIX WOBK OPEN-BREAKER KEYING

Fig. 34 shows interrupts A and B. The breaker 52b contacts close as the breaker opens to initiate ORTT transmitter keying (C); this permits a remote breaker to trip immediately if it is feeding a line fault with the local breaker open. Since the breaker may be opening due to an adjacent line fault, block C delays the trip signal for 32 ms to allow time for the remote zone 3 logic to reset.

Interrupt B initiates use of an alternative potential source if the line breaker(s) are being tripped by a local switch or by supervisory control and the program is using potential from that line. The potential selection logic similarly switches to another source, if a computer trip is threatening to deenergize the line-potential source in use.

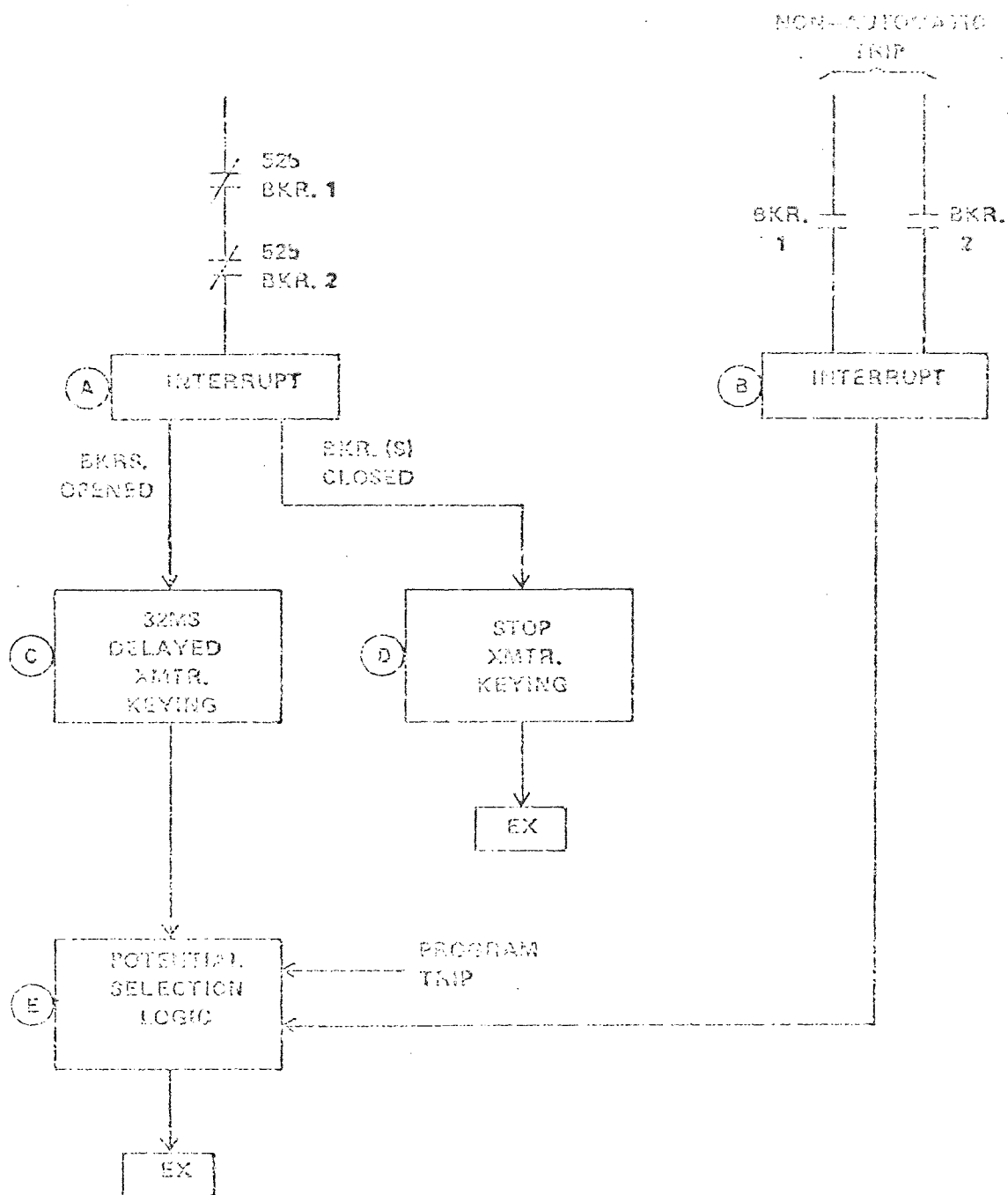

FIG. 24

ONK OPEN BREAKER KEYING

REFERENCES

- Freidlander, Gordon D., "Seismic and Sonic Instrumentation For Ocean Engineering", IEEE Spectrum, September, 1966, pp. 101-112.
- Harder, Edward L., Discussion of "Current Transformers and Relays For High-Speed Differential Protection With Particular Reference To Offset Transient Currents," AIEE Transactions, Vol. 59, 1940, pp. 1146-48.
- Hayward, C. D. "Prolonged Inrush Currents With Parallel Transformers Affect Differential Relaying," AIEE Transactions, Vol. 60, 1941, pp. 1096-1101, 1307.
- Penescu, C., "Digital Measurement of Active and Reactive Power," IEEE Transactions on Power Apparatus and Systems, July, 1965, pp. 609-621.
- Phister, Montgomery, Jr., "Logical Design of Digital Computers," John Wiley and Sons, 1961.
- Rockefeller, G. D. "Zone-Packaged Ground Distance Relay: I - Principles of Operation," IEEE Transactions, Vol. PAS-85, 1966, pp. 1021-44.
- Sonnemann, W. K., and H. W. Lensner, "Compensator Distance Relaying, I - General Principles of Operation," AIEE Transactions, Vol. 77, Part III, 1958, pp. 372-82, 392-402.
- Sonnemann, W. K., C. L. Wagner and G. D. Rockefeller, "Magnetizing Inrush Phenomena in Transformer Banks," AIEE Transactions, Vol. 77, Part III, 1958, pp. 884-892.
- Van C. Warrington, A. R., "Protective Relays," John Wiley and Sons, 1962.
- Wentz, E. C. and W. K. Sonnemann, "Current Transformers and Relays For High-Speed Differential Protection, With Particular Reference To Offset Transient Currents," AIEE Transactions, Vol. 59, 1940, pp. 483-485.
- Wagner, C. F. and R. D. Evans, "Symmetrical Components," McGraw-Hill, 1933.
- Wilson, R. G., "Digitally Controlled Receiver," IEEE Transactions On Aerospace and Electronic Systems, September, 1966.