

Copyright Warning & Restrictions

The copyright law of the United States (Title 17, United States Code) governs the making of photocopies or other reproductions of copyrighted material.

Under certain conditions specified in the law, libraries and archives are authorized to furnish a photocopy or other reproduction. One of these specified conditions is that the photocopy or reproduction is not to be “used for any purpose other than private study, scholarship, or research.” If a user makes a request for, or later uses, a photocopy or reproduction for purposes in excess of “fair use” that user may be liable for copyright infringement,

This institution reserves the right to refuse to accept a copying order if, in its judgment, fulfillment of the order would involve violation of copyright law.

Please Note: The author retains the copyright while the New Jersey Institute of Technology reserves the right to distribute this thesis or dissertation

Printing note: If you do not wish to print this page, then select “Pages from: first page # to: last page #” on the print dialog screen

The Van Houten library has removed some of the personal information and all signatures from the approval page and biographical sketches of theses and dissertations in order to protect the identity of NJIT graduates and faculty.

THE RECOVERY OF KRYPTON FROM DILUTE
GAS MIXTURES BY ELUTION TECHNIQUES

BY

DAVID GRAHAM BROWN

A THESIS
SUBMITTED TO THE FACULTY OF
THE DEPARTMENT OF CHEMICAL ENGINEERING
OF
NEWARK COLLEGE OF ENGINEERING

IN PARTIAL FULFILLMENT OF THE
REQUIREMENTS FOR THE DEGREE

OF

MASTER OF SCIENCE
WITH A MAJOR IN
CHEMICAL ENGINEERING

NEWARK, NEW JERSEY

1955

6155-1-11

ABSTRACT

An analytical method has been empirically developed for the analysis of dilute inorganic inert gas mixtures.

The method is based on a combined sorption-elution technique which makes possible the resolving of complex inert gas mixtures into their constituents.

Particularly the recovery of krypton from dilute gas mixtures was accomplished. Recovery efficiencies were as high as ninety-eight percent, while the average krypton purity was better than ninety-nine percent.

APPROVAL OF THESIS

FOR

DEPARTMENT OF CHEMICAL ENGINEERING

NEWARK COLLEGE OF ENGINEERING

BY

FACULTY COMMITTEE

APPROVED:

NEWARK, NEW JERSEY

JUNE, 1955

PREFACE

Heretofore analysis of inorganic inert gas mixtures required extensive equipment and was very difficult, if not sometimes impracticable.

In this work an attempt has been made to introduce a new technique in the analysis of inorganic inert gas mixtures. Such a technique involves the eluting of individual gases from an adsorbent containing a number of adsorbed gases. In this way inert gas mixtures can be conveniently separated into their constituents.

The work was done from an empirical view point and was not considered on a theoretical basis. Those interested in the theory of dynamic mixed adsorption will, I am sure, find sufficient references listed at the end of this volume.

It is hoped that this work will contribute in some small way to the field of analytical chemistry.

David G. Brown

ACKNOWLEDGMENTS

The author wishes to express his grateful appreciation to the persons who have rendered valuable assistance in this study. He is particularly indebted to Air Reduction Company, Inc. Research Laboratories for use of its facilities, and to Drs. G. K. Rauscher and E. R. Blanchard for suggestions and help.

David G. Brown

TABLE OF CONTENTS

CHAPTER	
I. <u>THE PROBLEM AND ITS SCOPE</u>	1
Purpose	2
Need for the Study	3
Delimitations	4
II. <u>REVIEW OF PREVIOUS WORKS AND THE ELUTION TECHNIQUE IN GENERAL</u>	5
III. <u>EXPERIMENTAL PROCEDURE</u>	9
Material and Apparatus	10
General Procedure (Including Preparation of Synthetic Samples)	14
Thermal Conductivity Analysis of Effluent Gases from Adsorbent Bed	20
IV. <u>EXPERIMENTAL RESULTS</u>	25
Elution Technique Variables	
1. Variation of Total Charcoal Volume of the Elution Column	26
2. Variation of the Flow Rates of the Eluting Helium	26
3. Determination of Nitrogen Elution Period	28
4. Separation of Krypton from Xenon	30
5. Performance of the Elution Apparatus	35
V. <u>DISCUSSION OF EXPERIMENTAL RESULTS</u>	37
VI. <u>SUMMARY AND CONCLUSIONS</u>	40

TABLE OF CONTENTS (CONT'D)

APPENDIX

Physical Properties of the Experimental Gases 43

REFERENCES 45

LIST OF FIGURES

FIGURE

I.	Basic Steps in the Separation of Two Gases by Elution Techniques.....	7
II.	Elution Apparatus.....	11
III.	Elution Column.....	12
IV.	Apparatus Used in Making Dilute Krypton Sample Mixtures.....	18
V.	Schematic Wiring Diagram of the Thermal Conductivity Cell.....	21
VI.	Schematic Diagram of Components Used in the Calibration of the Thermal Conductivity Cell.....	23
VII.	Typical Nitrogen Elution Curves.....	32
VIII.	Thermal Conductivity Curve of the Elution of Nitrogen, Krypton and Xenon at their Respective Temperatures.....	34

LIST OF TABLES

TABLE

I.	Composition of a Typical Dilute Krypton Gas Sample.....	19
II.	Results of Variation of Total Charcoal Volume of the Elution Column.....	27
III.	Determination of the Effect of Higher Helium Flow Rates on the Overall Krypton Recovery Efficiency.....	29
IV.	Thermal Conductivity Relations Used in Determining the Nitrogen Elution Period.....	31
V.	Determination of Charcoal Temperature Relationship in the Separation of Krypton from Xenon During the Elution of Krypton.....	35
VI.	Composition and Recovery of Krypton Samples Analyzed.....	36

CHAPTER I

THE PROBLEM AND ITS SCOPE

Purpose

Much experimental work has been done in the field of organic, inorganic and biological chemistry in which the use of elution technique plays a primary role. Chromatography, for example, employs such technique in the resolution of complex mixtures into their constituents.

The purpose of this work is to investigate the possibility of adapting such elution techniques in the recovery of pure inorganic inert gases in which one or more components are present in very small concentrations. Particularly the recovery of krypton from dilute gas mixtures by elution techniques is to be studied.

Need for the Study

The major interest in the work lies in its use in the analytical investigation of inert gases.

Delimitations

The investigation was considered from an empirical point of view and was carried out with only the separation of krypton from an adsorbent containing one or more other adsorbed gases by elution techniques as the primary function of the research. The phenomenon of dynamic mixed adsorption is not considered. However, the assumption is made that substantially all of the krypton from the starting mixtures was adsorbed.

Selection of suitable conditions for effective separations of mixtures was based on arbitrary, empirical procedures.

No attempt was made to develop the work on an engineering basis, but rather to obtain laboratory data on the separation and recovery of krypton.

CHAPTER II

A REVIEW OF PREVIOUS WORK AND
ELUTION TECHNIQUE IN GENERAL

The dictionary defines the word elution as "The removal or separation of impurities by washing; especially in sugar-refining, the washing of sucrose of lime with water so as to remove any soluble impurity".

Many investigators have experimented with the possibility of separating the rare gases by sorption techniques. Among them, [Peters and Weil Z. physik Chem. A 148, 1 (1930)] adsorbed argon, krypton and xenon on charcoal and then tried to quantitatively desorb the individual gases. Their work did not prove to be successful, for they were incorrect in assuming that the gases would have no influence on each other's sorption.

In this work, if we assume that krypton from dilute gas mixtures is essentially quantitatively adsorbed on charcoal under conditions of temperature, pressure and adsorbent surface that would insure a large safety factor, it follows, from Peters and Weil (ibid) experiments that removing interfering gases before attempting to desorb the krypton would be the most natural thing to try. This thought led to the designing of an apparatus and determination of eluting techniques which would allow the quantitative separation of krypton.

In Figure I., the basic steps in the separation of two gases by elution technique are graphically shown. Column A, shows the distribution of two gases, 1 and 2 in a sorption column. Addition of elutant in column B begins to separate gas 2 from gas 1. Continued addition of elutant produces the final separation of gas 2 from gas 1 by differential migration (plus the other factors which are beyond the scope

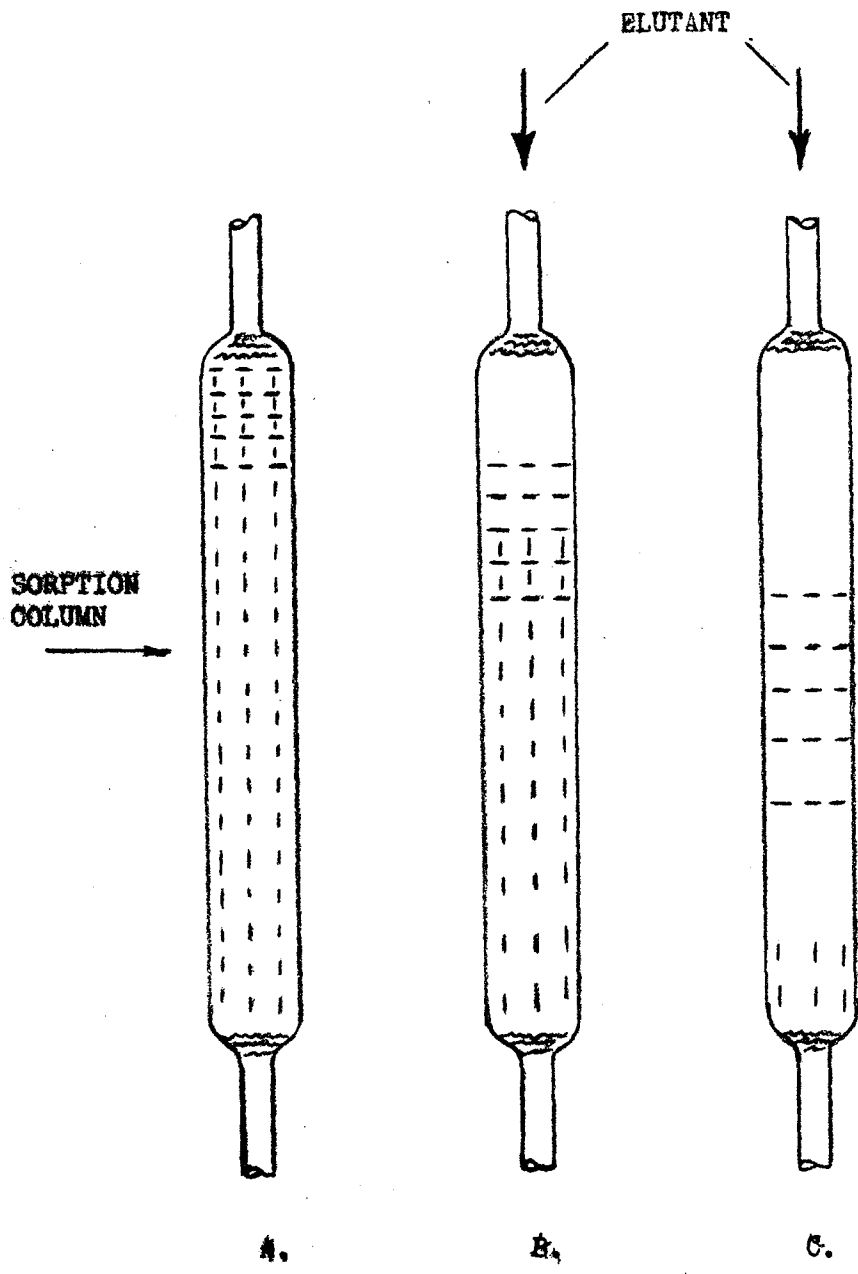

FIGURE I. BASIC STEPS
IN THE SEPARATION OF
TWO GASES BY ELUTION
TECHNIQUE.
- GAS 1
' GAS 2

of this work) as represented in column C.

In the application of elution techniques in the recovery of krypton from dilute gas mixtures, it is meant that unwanted gases are eluted or washed from an adsorbent with helium. The wanted material is retained on the adsorbent by controlling temperature, pressure, flow rates and other factors all of which will be discussed later on.

CHAPTER III

EXPERIMENTAL PROCEDURE

Materials and Apparatus

The heart of the apparatus used for the study of the recovery of krypton from dilute gas mixtures by elution techniques is the elution column. Figure II shows the elution column connected in the completed apparatus, while Figure III shows details of the elution column.

The elution column consists of two slender charcoal tubes arranged so that they can be refrigerated either separately or together. The tubes are connected in series, with vent and vacuum connections in the line between the tubes. The purpose of dividing the elution column into two parts is to make it possible to use a smaller volume of charcoal during the elimination of most of the nitrogen and argon.

The first of the two charcoal tubes comprising the elution column is called the collection trap. The charcoal in this trap is Columbia activated carbon, grade 6-G (Carbide and Carbon Chemical Corp.). The collection trap is refrigerated with liquid oxygen contained in a quart sized stainless steel dewar. The second tube of the elution column is about nine in. (22 cc.) of 70x80 mesh charcoal in a 1/2 in. copper tube. The elution column holds a total (for both tubes) of 32 cc. of charcoal. The elution column is fitted with an Ashcroft compound gauge (30 in to 15 psi). Water pumped cylinder nitrogen (dried through two, one in. O.D. by 24 in. long indicating Drierite Towers) is used in the elution column activation procedure (see General Procedure). The elution column is connected to the high vacuum manifold (5/8 in. OD copper tubing) which in turn is connected to a cold trap and a Welch Duo-seal vacuum pump. Helium is supplied to the elution column through a needle

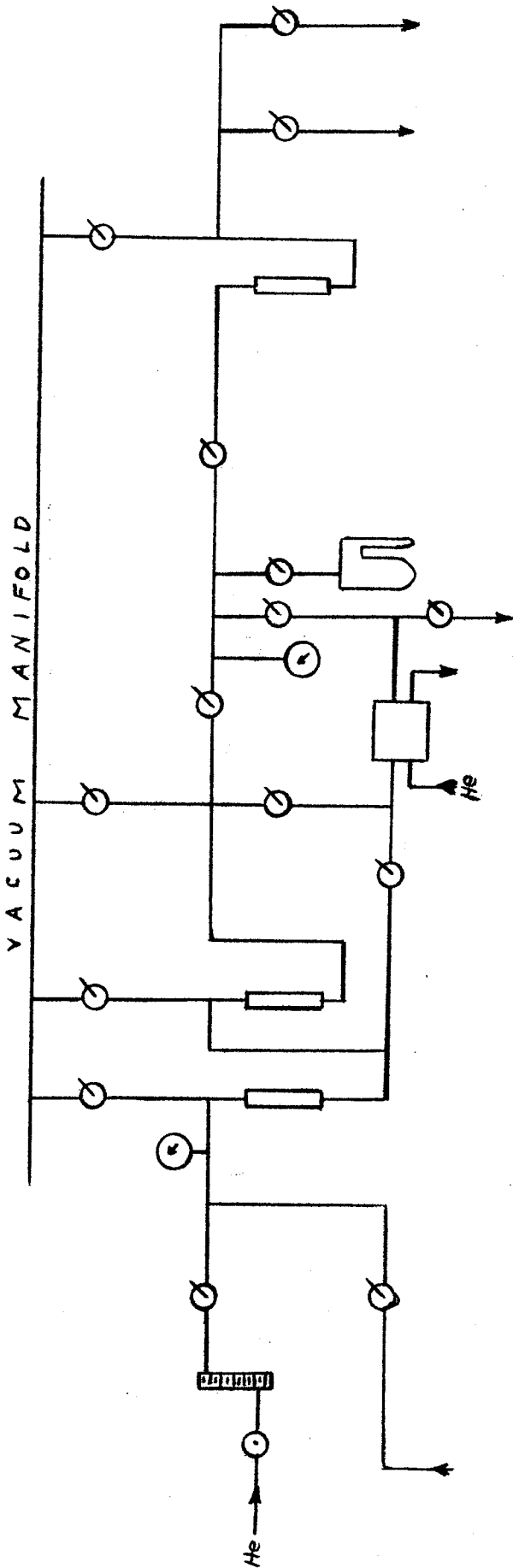

VENT

SPECTROGRAPHIC ANALYSIS
SAMPLING

KRYPTON TRAP

ZIMMERLI GAUGE

VENT
PRESSURE GAUGE

THERMAL CONDUCTIVITY
CELL

COLLECTION TRAP } ELUTION COLUMN

PRESSURE GAUGE

FLOWMETER

FROM SAMPLE
CYLINDER

FIGURE 11
ELUTION APPARATUS

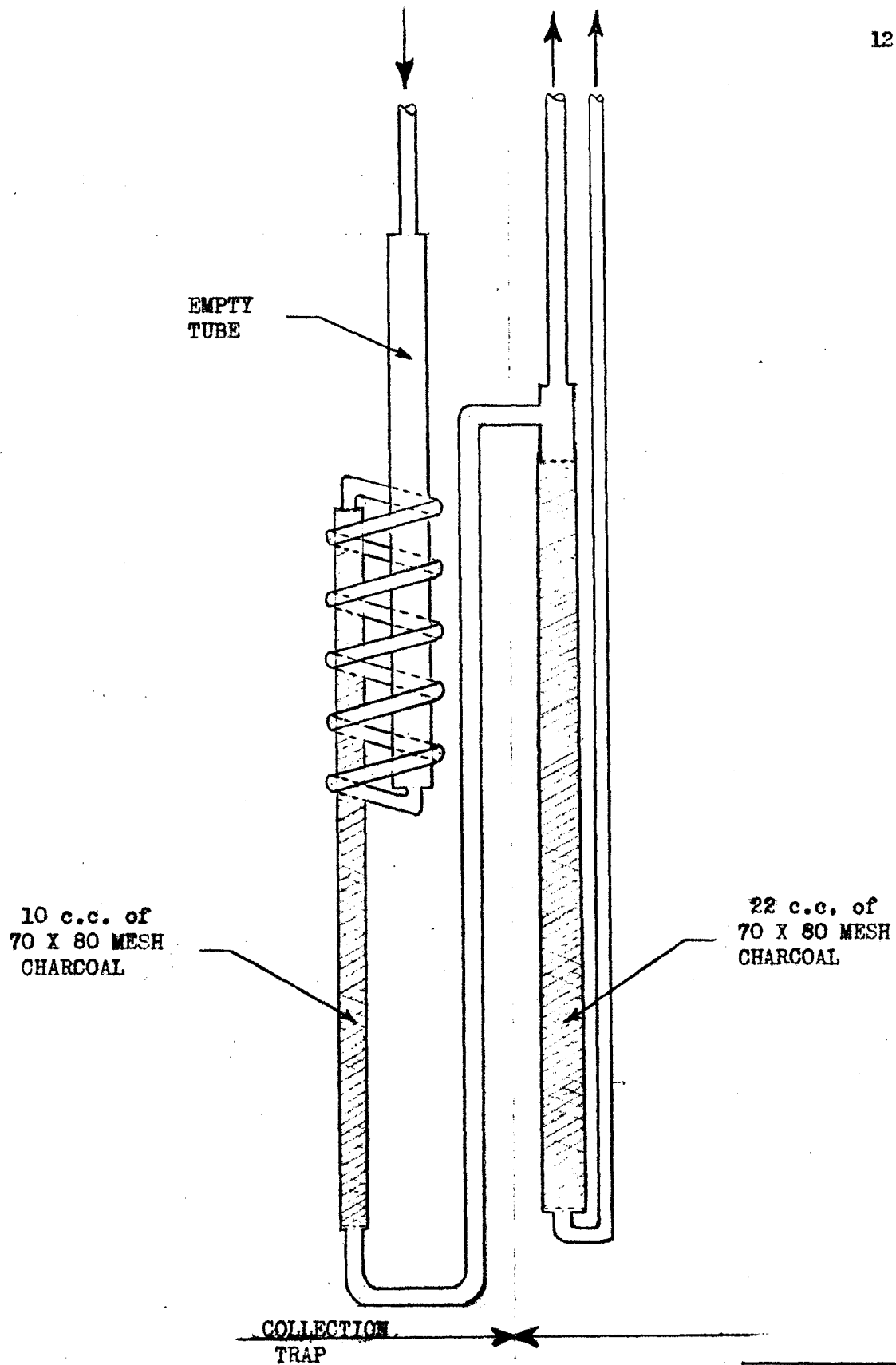

FIGURE III
THE ELUTION COLUMN
MATERIAL: COPPER & BRASS
TUBING
SILVER SOLDER
CONNECTIONS
SCALE 1/2" = 1"

valve and flowmeter. The eluting helium is commercial cylinder grade XX helium. This is the purest grade of commercial helium. However, in order to insure its purity before using it in the elution steps, the helium is passed through three charcoal tubes (not shown in Figure II) cooled to minus 195 degrees C. with liquid nitrogen. The tubes (1 in. OD by 18 in. copper tubing) are connected in series in a vertical bank so that one large dewar can surround all of them at one time. A Fischer and Porter Flowrator (serial No. S12/1019-3) is used in measuring the eluting helium flowrates. Venting of any non-adsorbable gases during the use of the elution column is through a small Brooks flowmeter and a mercury sealed trap (not shown in Figure II) before venting to the atmosphere. A Gow-Mac thermal conductivity cell is used to determine the effluent gas composition during the elution period and any other processing step where the composition of such effluent gas or gases is desired to be known. The thermal conductivity analysis is discussed under a separate section in this chapter.

Almost all of the connecting lines of the elution section are 3/8 in. OD copper tubing, with silver soldered fittings.

In order to clarify Figure II, processing of a typical dilute krypton gas sample step by step may be seen by referring to the General Procedure section of this chapter.

General Procedure

The following was the general experimental procedure used in the recovery of krypton from the prepared dilute gas samples by elution technique.

1. The elution column was reactivated and pumped out.
2. The first leg of the elution column (collection trap) was refrigerated with liquid oxygen.
3. The sample gases were passed from the synthetic sample cylinder through the collection trap. The sample flow was adjusted to about 175 cc. per minute.
4. When the pressure in the elution column reached 2 to 3 psig. the exhaust valve was opened cautiously.
5. When the sample flow could no longer be maintained at 175 cc. per minute, the sample cylinder valve was closed.
6. The sample cylinder was then filled with nitrogen to 5 psig. Opening the cylinder again and then adjusting the flow gave the same rates as in step 3.
7. After all flow ceased, the sample cylinder valve was closed.
8. The collection trap was allowed to stand in liquid oxygen for 20 minutes.
9. Then the elution column was pumped out as follows: The manifold valve was adjusted so that the pressure in the collection trap fell at the rate of two and one half inches of mercury per minute. When the pressure had fallen below twenty five inches vacuum, the manifold valve was opened wide and pumping was continued until the pressure in the elution column, with the manifold valve closed, was 10 mm. mercury absolute.

10. With all the valves closed, the liquid oxygen was removed from the collection trap and immediately a dry ice bath was applied to all of the elution column.
11. Helium was passed through the elution column by opening the helium needle valve. The helium pressure in the elution column was allowed to build up to 2 psig. and then slowly the valve to the thermal conductivity cell was opened. The helium flow was adjusted to 200 cc/min.
12. The elution of nitrogen and argon from the elution column with helium was continued until the T/C cell indicated pure helium.
13. Then the valve to the refrigerated (liquid nitrogen) krypton trap was opened, so that the effluent helium of the elution column passed through the krypton trap and then was vented to the atmosphere.
14. The dry ice bath was removed from the elution column. As the elution column warmed to room temperature, the krypton began to appear in the effluent helium stream of the elution column. The krypton was collected in the krypton trap for reuse, its volume measured and was checked for purity by spectrographic analysis.

Reactivation of elution column and krypton trap.

1. With the elution column heater adjusted and plugged in, the purging nitrogen needle valve was opened.
2. When pressure in the elution column reached 2 psig., the nitrogen was vented to the atmosphere. The flow was set at 175 cc./min. The heat and nitrogen flow were continued for one hour.
3. Then all valves were closed, the heater was disconnected and removed.
4. While the elution column was cooling, it was pumped out via the

vacuum manifold connection. When the pressure reached 25 in. mercury vacuum, all valves were opened for additional pumping.

5. The pumping was allowed to continue for 15 minutes.
6. Then all valves were closed.

Preparation of dilute krypton gas samples. The samples were made with the use of a pyrex glass manifold with a gas Burette, Manometer and sample gas bulb, with other needed accessories connected (see flow diagram Figure IV. attached). The gases used for the preparation of the samples included reagent grade krypton and xenon, pre-purified cylinder nitrogen and commercial cylinder argon. Measured amounts of krypton and xenon (when used as a sample component) were made up in a double ended metal bulb which was then connected to a large, clean (500 cu. in.) evacuated cylinder. The krypton and xenon were allowed to enter the cylinder due to the pressure difference and then the sample bulb and lines were flushed through with prepurified cylinder nitrogen, to make up the desired synthetic sample composition.

Other samples were made up in smaller cylinders (175 cu. in. internal volume) as follows: The whole system is evacuated and krypton is introduced into the Burette and measured at atmospheric pressure. Then part of the krypton is allowed to enter the cylinder and by measuring the difference from the total volume at first; the amount of krypton used for the sample was determined. The other sample gas volumes were determined the same way. Table I gives the composition of a typical dilute gas sample, used in this investigation.

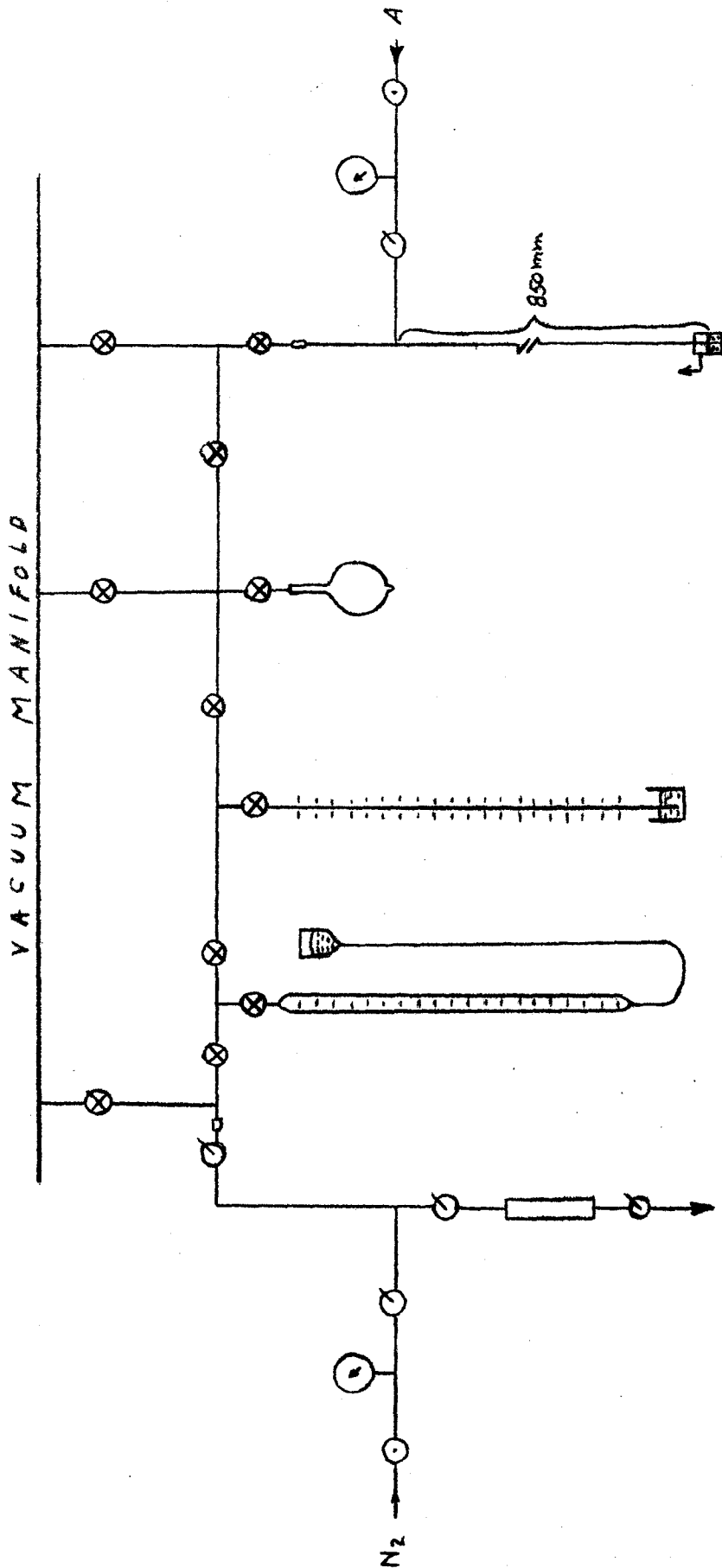

PRESSURE GAUGE

MERCURY SAFETY TRAP

KRYPTON OR XENON FLASK

MERCURY MANOMETER

MERCURY GAS BURETTE

SAMPLE BULB & TO SAMPLE CYLINDER

PRESSURE GAUGE

FIGURE IV. APPARATUS USED IN MAKING DILUTE KRYPTON SAMPLE MIXTURES.
 ● NEEDLE VALVE
 ◊ TOGGLE VALVE
 ● GLASS STOPCOCK

TABLE ICOMPOSITION OF A TYPICAL DILUTE KRYPTON GAS
SAMPLE

Gas	Composition (% by volume)
Krypton	0.1
Xenon	0.03
Argon	2.0
Nitrogen	97.9

Thermal Conductivity Analysis of Effluent Gases from Adsorbent Bed

Description of the thermal conductivity unit. The unit consists of the following components:

1. Recorder - the recorder was a Minneapolis-Honeywell 0-2.5 millivolt full scale strip chart pen recorder.
2. Power Supply - this component maintained a steady current through the sensitive element wheatstone bridge over a long period of time.
3. Cell Unit - the heart of this unit was a special Gow-Mac thermal conductivity cell. A schematic wiring diagram of a typical cell is shown in Figure V. This cell was electrically compensated for possible temperature and current changes. The cell was mounted in a carefully insulated container to keep surrounding temperature fluctuations to a minimum.
4. Gas control equipment - the rest of the unit comprises flow controllers and piping which were strategically placed for relatively quick cell response and stability. Also a high purity cylinder of helium (XX grade) was incorporated in the unit as the reference gas standard.

Brief discussion of the thermal conductivity cell design.

1. Sensitivity - the sensitivity was set as high as possible.
2. Sampling - the amount of sample required was as little as 0.1 s.e.f.h. for continuous analysis.

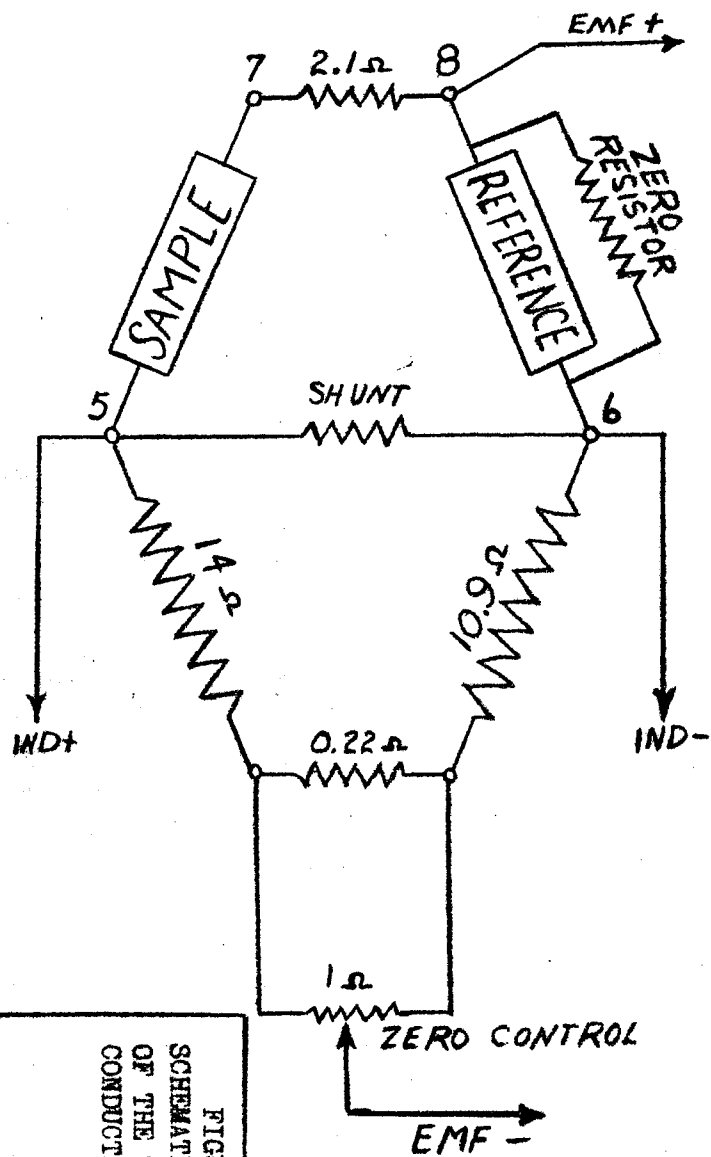
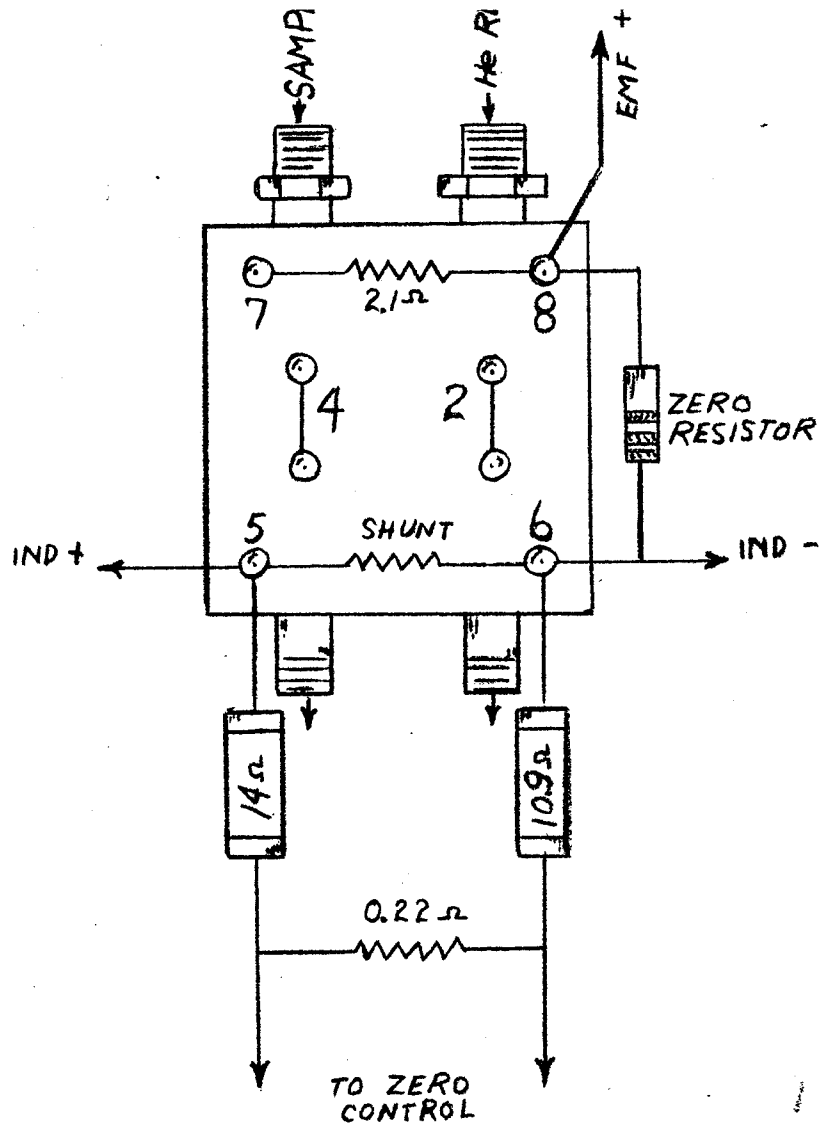

FIGURE V.
SCHEMATIC WIRING DIAGRAM
OF THE THERMAL
CONDUCTIVITY CELL



NOTE: IF ZERO IS NOT OBTAINABLE WITH ZERO CONTROL, ZERO RESISTOR MAY BE CHANGED.
ALL VALUES ARE TYPICAL.

3. Versatility - the unit was designed to be used for many gases.

Discussion of operation.

1. Effect of temperature on cell operation - with the high sensitivity blocks electrically compensated, the recorder would move no more than 1% full scale with a 10 degree F. temperature change.
2. Current fluctuations - in addition to the current regulated power supply, it was possible to compensate the cell block so that a 10 % change in current would only cause the recorder to change 1 % full scale.
3. Gas sampling - the effect of pulsation and changes of flow are critical to the stability of these units. Temperature and current compensations have reduced these effects considerably. In addition, the sampling system was designed to maintain a constant flow with a minimum of pulsations.

Calibration of the Thermal Conductivity Unit. A schematic diagram of the components used for the calibrations of the T/C cell is shown in Figure VI.

First the cell was balanced (Zeroed with pure helium) flowing through the sample section of the thermal conductivity cell. With a zero point thus established on the recorder chart paper, mixtures of two and fifty percent by volume nitrogen and helium respectively were used to determine the recorder full scale shunt resistance for these

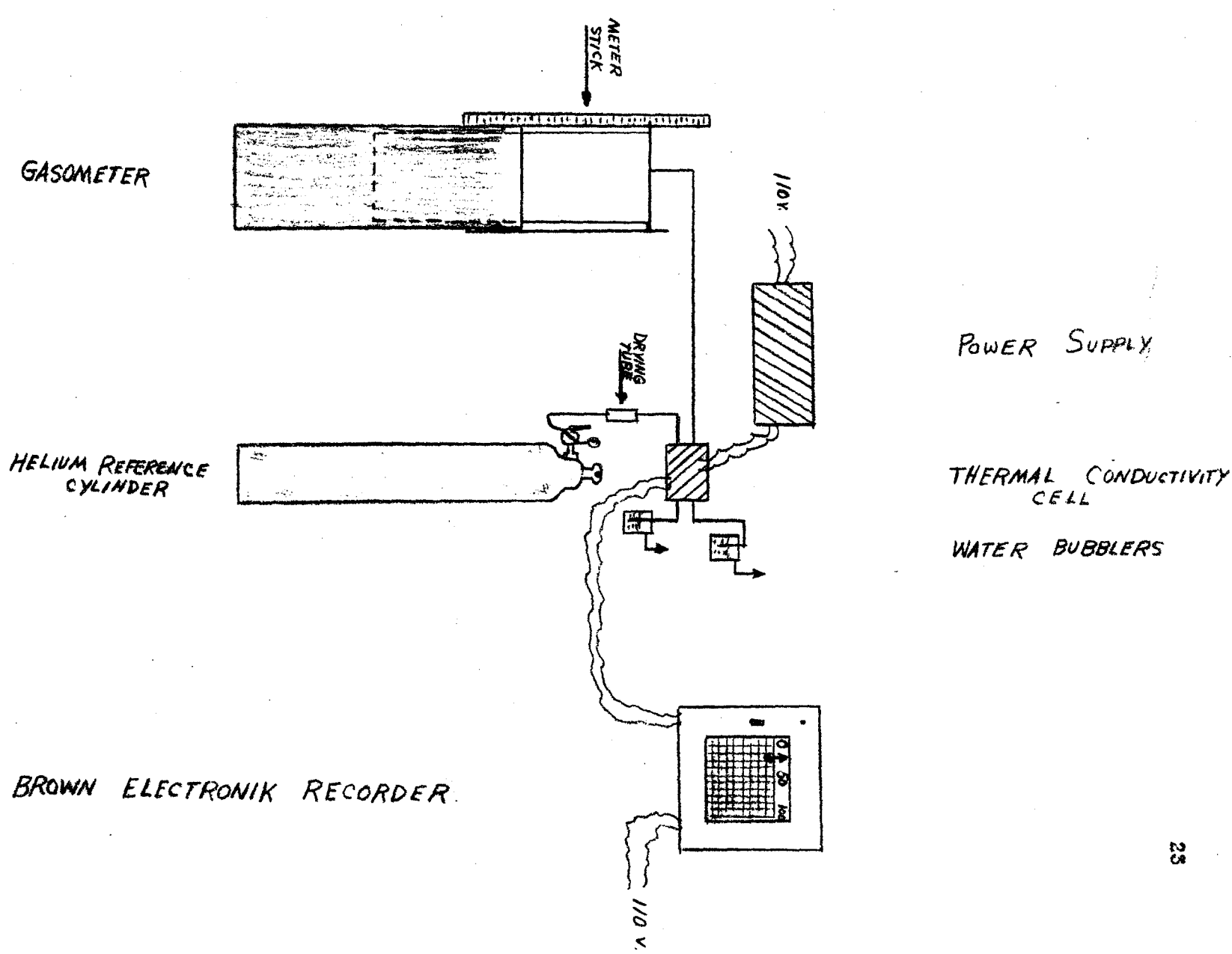

GASOMETER

HELIUM REFERENCE CYLINDER

BROWN ELECTRONIK RECORDER

METER STICK

110V

POWER SUPPLY

THERMAL CONDUCTIVITY CELL

WATER BUBBLERS

110 V.

FIGURE VI. SCHEMATIC DIAGRAM OF COMPONENTS USED IN THE CALIBRATION OF THE THERMAL CONDUCTIVITY CELL

two mixtures. With mixtures of one and twenty five percent by volume nitrogen and helium respectively the thermal conductivity cell recorder calibration was checked and the resulting deflections were exactly one half of their full scale. With these points determined, it was assumed that the respective deflections of the recorder against the concentration of nitrogen in helium was a linear relationship. Therefore by selection of the proper shunt resistance valve any concentration of nitrogen in helium from zero to two percent by volume, and from zero to fifty percent by volume, may be read from the recorder chart, at any given time.

Calibration with krypton was not accomplished, since its cost made its use prohibitive.

CHAPTER IV

EXPERIMENTAL RESULTS

Elution Technique Variables

1. Variation of total charcoal volume of the elution column.

Several runs were made using a smaller volume (10cc rather than 22cc) of 70 by 80 mesh Columbia 6 G charcoal in the second tube of the elution column in an attempt to accomplish the elution of nitrogen and argon in less time. The experimental procedure is the same as that listed in the General Procedure in Chapter III. This smaller charcoal volume was found to be insufficient to retain the krypton with as high a recovery efficiency as the larger volume of charcoal (see results under Performance). Table II shows the results of these two experiments using 10 cc of charcoal in the second tube of the elution column.

From the results as shown in Table II as compared with results in Performance Section, it can be seen that some of the krypton was apparently lost due to the smaller amount of charcoal present. Therefore the larger volume of charcoal (22cc) of the two volumes studied allows more efficient adsorption of krypton by the elution column (collection trap) although this volume (22cc) may not be the optimum amount.

2. Variation of the flow rates of the eluting helium. The synthetic samples were processed as per the Processing Procedure given in Chapter III. Conditions other than the eluting helium flow rate remained the same. In order to determine any possible "break through" of krypton during the flow rate experiments, the effluent gases from the elution column were passed through the thermal conductivity unit¹, before being vented to the atmosphere.

¹ A discussion of the Thermal Conductivity Unit is given in the Material and Apparatus Section (Chapter III).

TABLE II

RESULTS OF VARIATION OF TOTAL CHARCOAL VOLUME OF THE ELUTION COLUMN

Sample No.	Composition of Synthetic Sample				Elution Column Charcoal Volume		N ₂ Elution Period minutes	Kr Recovery	
	A cc.	N ₂ cc.	Kr cc.	Xe cc.	Collect Trap cc	Second Tube cc		cc	%
X-6	---	16,000	113	---	10	10	60	97	86
X-7	---	16,000	117	---	10	10	60	84	72

Helium eluting flows of 200, 350 and 500 cc. per minute were investigated. As seen from the results listed in Table III, all these flow rates gave approximately the same final high percentage of krypton recovery.

From the results as shown in Table III, it was established that the final operating nitrogen and argon eluting helium flow rate of 200 cc. per minute was well within a given maximum flow rate (other conditions remaining the same). This flow rate insures a minimum wastage of sample during the elution of nitrogen and argon.

3. Determination of Nitrogen Elution Period. After the sample has been adsorbed in the collection trap at minus 183 degrees C. the trap is closed off and the pressure is reduced by evacuation, initially from the down stream side and finally from both sides, to about 10 mm Mercury absolute. This effects removal of a large part of the adsorbed argon and nitrogen; the xenon and krypton remain adsorbed. The collection trap is then warmed rapidly to minus 80 degrees C. and held at that temperature. Desorbed gases pass into the second charcoal column (of the elution column) also held at minus 80 degrees C. Any gases (i.e. some of the nitrogen and argon) not adsorbed in the second column are vented to the atmosphere. With the entire elution column held at minus 80 degrees C. (dry ice), the remaining argon and nitrogen are removed by elution with a stream of pure helium and are vented to the atmosphere.

Using the same thermal conductivity equipment and a eluting helium flow of 200 cc per minute, thermal conductivity relations were obtained

TABLE III

DETERMINATION OF THE EFFECT OF HIGHER HELIUM ELUTING FLOW RATES
ON THE OVERALL KRYPTON RECOVERY EFFICIENCY

Sample No.	Composition of Synthetic Sample				Eluting Helium Flow Rate cc/min.	Nitrogen Elution Period (min.)	Krypton Recovery	
	A cc.	N ₂ cc.	Kr cc.	Xe cc.			cc.	%
X-4	---	16,000	110	---	350	32	105	96
X-5	---	16,000	106	---	500	26	101	96

of the rate of nitrogen removal with time. The synthetic samples were processed as per the processing procedure. Table IV gives the experimental results.

Since there was apparently no wastage of krypton during the 90 minute elution period, the elution duration was standardized at 90 minutes with a helium flow rate of 200 cc. per minute. Synthetic samples containing less N_2 and A, required less eluting time to reach $< 0.2\% N_2$ in helium effluent concentration.

Longer (than 90 min.) elution periods have been investigated and the rate of N_2 removal after 90 minutes is almost the same up to 4 hours. No loss of krypton could be determined over this 4 hour elution period.

Figure VII shows a typical nitrogen elution curve.

4. Separation of Krypton from Xenon. The krypton is removed from the elution column at room temperature by also eluting with pure helium. The xenon remains adsorbed on the charcoal at that temperature (about 20 degrees C.). The above facts were determined with the use of thermal conductivity data. Table V lists the experimental conditions used in obtaining the typical elution curve (Fig. VIII,) of a nitrogen, krypton and xenon gas sample mixture.

It is evident that the separation was accomplished by control of the elution column charcoal temperature (along with the eluting time periods), which allowed selective elution of the respective gases.

The dotted lines of the attached Figure VIII represent indefinite periods of time, since the peaks of the curves are related to the time

TABLE IV

THERMAL CONDUCTIVITY RELATIONS USED IN DETERMINING THE NITROGEN ELUTION PERIOD

Sample No.	Composition of Synthetic Sample				Nitrogen Elution Period Needed to Reach <0.2% Nitrogen in Helium minutes	Kr Recovery	
	A cc.	N ₂ cc.	Kr cc.	Xe cc.		cc.	%
X-3	---	16,000	87	---	87	80	92
X-8	---	16,000	101	10	70	--	--
X-37	650	325	78	12	40	73	94
X-38	645	325	43	15	38	40	93
X-39	645	325	59	12	42	55	93

FIGURE VII. TYPICAL NITROGEN ELUTION CURVES.

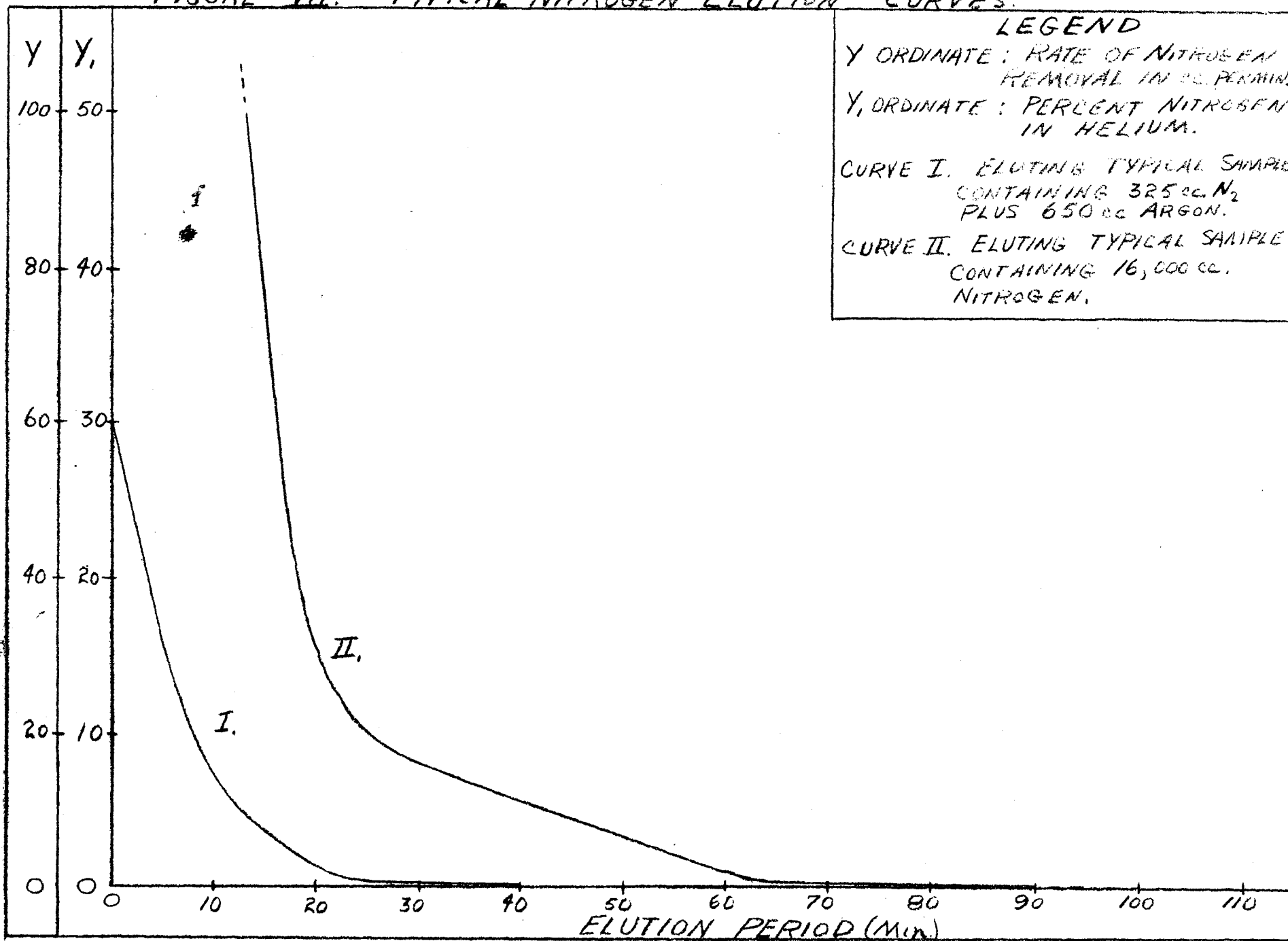

TABLE V

DETERMINATION OF CHARCOAL TEMPERATURE RELATIONSHIP IN THE SEPARATION OF KRYPTON
FROM XENON DURING THE ELUTION OF KRYPTON

Sample No.	Synthetic Sample Composition				Elution Conditions					
	A	N ₂	Kr	Xe	Nitrogen Elution		Krypton Elution			
	cc.	cc.	cc.	cc.	Elution Column	Elution He Flow Rate	Elution Time	Elution Column	Elution He Flow Rate	Elution Time
					Temp ^o C.	cc/min.	(min.)	Temp ^o C.	cc/min.	(min.)
X-8	--	16,000	101	10	-78	200	70	20	60	30

Sample No.	Xenon Elution		
	Elution Column	Elution He Flow Rate	Elution Time
	Temp. ^o C.	cc/min.	(min)
X-8	Ca. 100 ⁽¹⁾	60	40

(1) Maximum temperature near the outside wall of the elution column was 140 degrees Centigrade.

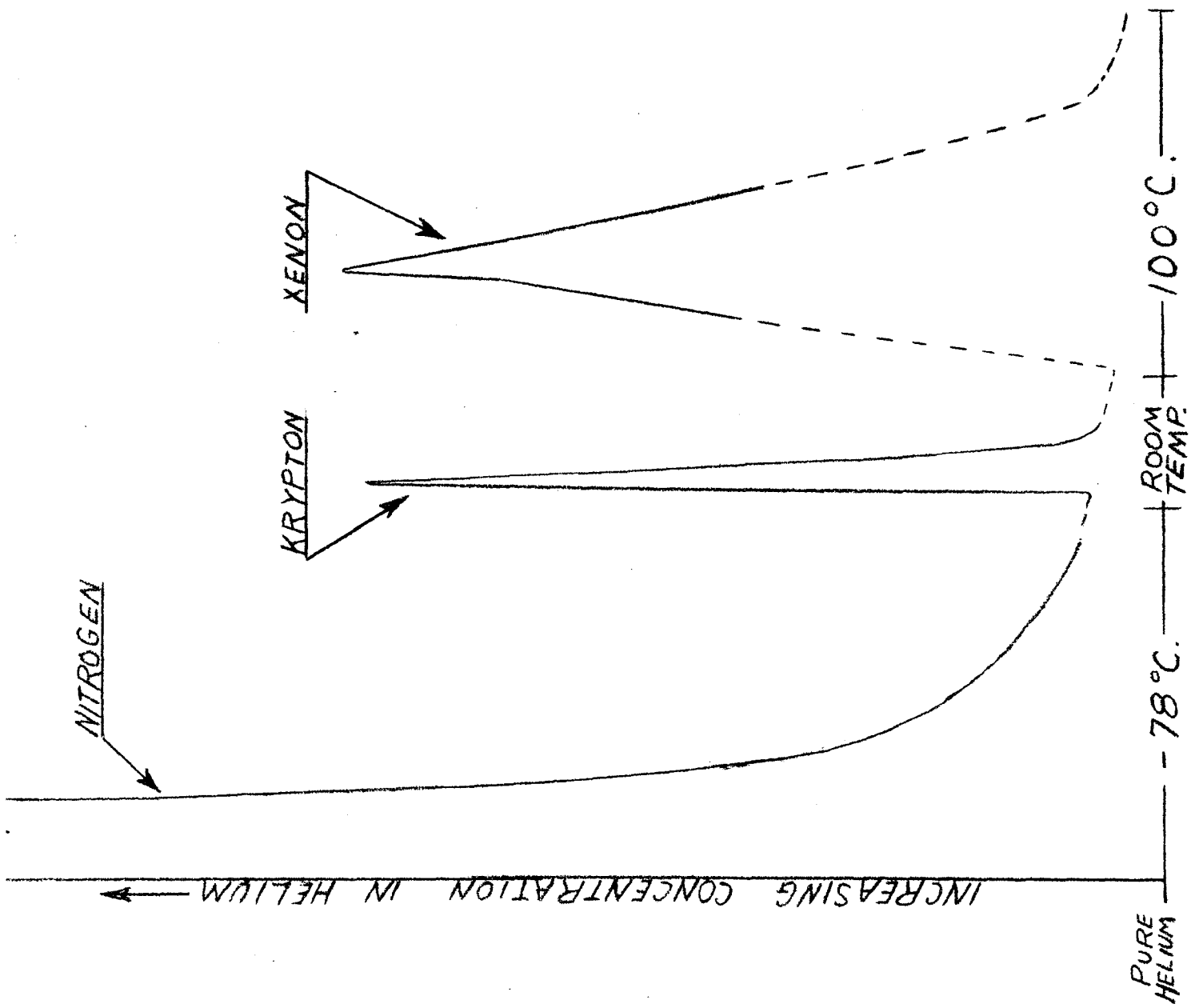

FIGURE VIII. THERMAL CONDUCTIVITY CURVE OF THE ELUTION OF **NITROGEN**, KRYPTON AND XENON AT THEIR RESPECTIVE TEMPERATURES.

(other conditions remaining the same), only through the rate of heat transfer from the surroundings to the charcoal. It is very important to keep clearly in mind that the thermal conductivity unit was calibrated only for mixtures of nitrogen and helium and therefore the last two curves are only a relative indication of concentration of krypton or xenon in helium. The xenon and krypton curves were determined using the two percent nitrogen in helium scale of the thermal conductivity unit recorder.

After the eluting of the krypton, it took approximately 15 minutes after heat was applied to the elution column before any xenon appeared in the effluent helium gas stream.

5. Performance of the Elution Apparatus. A number of samples were analyzed and it was found that the apparatus and elution procedures gave very good krypton recovery efficiency.

Table VI. summarizes these results.

In order to check the performance of the apparatus and elution procedures after empirically determining their operating limits above, a number of dilute krypton samples were analyzed. The krypton was collected in the krypton trap (Figure II), and desorbed into a calibrated volume for percent recovery measurement. Purity of the recovered krypton was checked by spectrographic analysis. Table VI summarizes these results.

TABLE VI
COMPOSITION AND RECOVERY OF KRYPTON SAMPLES ANALYZED

Sample No.	Volume of Krypton used in making sample ¹		Krypton Recovered	
	Krypton cc.	Xenon cc.	cc.	%
X-36	59	---	50	93
X-40	47	---	46	98
X-42	40	---	29	73
X-43	82	---	45	55
X-44	71	---	60	85
X-45	54	---	45	83
X-46	69	---	55	80
X-47	26	---	22	85
X-48	34	---	31	91

¹ All samples contained Nitrogen. Some samples contained argon as well as nitrogen.

CHAPTER V

DISCUSSION OF EXPERIMENTAL
RESULTS

As mentioned before, the variables were investigated not necessarily from a theoretical stand point but from an empirical view point. The variables investigated were considered to be the most pertinent in the development of a method of recovery of krypton by elution techniques.

In the study of the elution column total charcoal volume as a function of nitrogen eluting time, the results indicate that 10 cc. of charcoal (in the second tube) approximate a sufficient volume to recover the krypton and yet allow less time for the eluting of nitrogen. In other words, 22cc. of charcoal is more than enough to adsorb the krypton at minus 78 degrees C.

The variables, eluting helium flow rate, charcoal bed temperature and amount of charcoal are obviously the significant factors in the elution technique. Better correlation of the above variables in determining more precisely the optimum operating conditions, and correlating all results by statistical methods is suggested.

Charcoal bed temperatures, other than those reported were not investigated since these various sorption temperatures, were the most conveniently obtainable.

The eluting helium flow rates investigation indicates that higher helium flow rates can safely be used, thus lowering the time needed for the elution of nitrogen and argon, and still maintain the overall high percentage of krypton recovery.

Samples containing higher concentrations of nitrogen were found to have longer nitrogen elution periods, as expected.

It was determined that there is an additional small amount of nitrogen eluted from the elution column during the first stages of eluting the krypton from the elution column to the second trap (Krypton trap, Figure II,). This small amount of nitrogen can be removed by chemical means before the pure krypton is measured to determine the recovery efficiency.

It should be noted that the krypton recovery efficiencies give promise to quick and relatively easy, as well as a semi-quantitative analytical method for the krypton analysis of inert gas mixtures.

Every effort was made to maintain constant, all variables, except the one being experimentally investigated.

CHAPTER VI

SUMMARY AND CONCLUSIONS

Variables that were studied in the development of an analytical method for determining krypton in dilute gas mixtures were as follows; (1) Variation of total charcoal volume of the elution column, (2) Variation of the flow rates of the eluting helium, (3) Determination of Nitrogen elution period, and (4) Separation of Krypton from Xenon by elution with helium.

In varying the total charcoal volume, it was established that the total selected volume of adsorbent (22cc.) was more than sufficient to adsorb all of the krypton and still allow increased helium elution flow rates.

In the operation of the elution column, if the total amount of charcoal is decreased, it is possible to also decrease the length of time required for the nitrogen elution period at a eluting helium flow rate of 200 cc./min. However, with smaller volumes of adsorbent there is the chance of not initially adsorbing all of the krypton.

With the selected total volume of charcoal (22 cc.) in the elution column it was possible to increase the flow rates of eluting helium up to 500 cc/min. and still obtain the high percentage of krypton recovery.

The nitrogen elution period was established to be 90 minutes when samples contained approximately 98 percent nitrogen. Of course, when samples contained less nitrogen it required less time for the nitrogen elution period. In order to standardize the operation, a nitrogen elution period of 90 minutes was arbitrarily selected.

In the separation of krypton from xenon it was found that with a helium flow rate up to 200 cc/min., the krypton could be easily separated from xenon by controlling the temperature and time of the helium eluting period.

To sum up, the operating limits for the recovery of krypton from dilute gas mixtures by elution techniques are as follows:

Total charcoal volume of the elution column to be 32 cc.

Helium elution flow rates 200 to 500 cc/min.

Nitrogen elution period 90 minutes.

Separation of krypton from xenon at room temperature was complete after 40 minutes with an eluting flow rate up to 200 cc/min.

A high percentage of krypton has been recovered from dilute gas mixtures with the use of elution techniques. Certain variables have been empirically determined which have lead to increased efficiency of operation as well as giving the limiting operating conditions of an apparatus especially designed for the development of elution technique in the recovery of krypton from inert gas mixtures.

It can be concluded from this experimental work that krypton can be separated from other inert gases by a combined sorption-elution technique.

APPENDIX

PHYSICAL PROPERTIES OF THE EXPERIMENTAL GASES. REFERENCE: INTERNATIONAL CRITICAL TABLES.

Chemical Symbol	Atomic Weight	B.P. °C.	M.P. °C.	Density °C. & 1 atm. g/l	Thermal Conductivity °C. K X 10 ⁶	Coefficient of Viscosity poises η X 10 ⁷	Latent Heat of Vaporization, l.g-cal. (15°C). per g.
A	39.91	-185.7	-189.2	1.7824	38.2	2210	37.6
He	4.00	-268.9	---	0.1785	339.0	1960	6
H ₂	1.008	-252.7	-259.1	0.08987	396.5	880	108
Kr	83	-151.8	-169.	3.708	21.2	2436	---
N ₂	14.008	-195.8	-209.8	1.2506	58.0	1770	47.6
O ₂	16.000	-183.0	-218.4	1.4290	58.39	1960	50.9
Xe	130.2	-109.1	-140.	5.851	12.4	2260	---

APPENDIX CONT'D

PHYSICAL PROPERTIES OF THE EXPERIMENTAL GASES. REFERENCE: INTERNATIONAL CRITICAL TABLES.

Chemical Symbol	t_c °C.	Critical Constants		Heats of Adsorption (Coconut Charcoal at -185°C. from 0 to ca 760 mm)		
		P_c atm.	d_c g/cm ³	A cc(g)/cc(s)	Q joule	Q/A
A	-122.4	48.0	0.531	175	104	.59
He	-267.9	2.26	0.069	15	8.3	.55
H ₂	-239.9	12.8	0.0310	135	38.	.28
Kr	-62.6	54.2	---	---	---	---
N ₂	-147.1	33.5	0.311	155	106	.68
O ₂	-118.8	49.7	0.430	230	142	.61
Xe	16.6	58.2	1.15	---	---	---

REFERENCES

- Beryl, W. G., Physical Methods in Chemical Analysis Vol. II. Academic Press.
- Brunauer, S., The Adsorption of Gases and Vapors Vol. I. Physical Adsorption, Princeton University Press, Princeton, N.J. (1945)
- Chapman, S. and Cowling, T. G., The Mathematical Theory of Non-Uniform Gases Cambridge University Press (1939).
- Chemical Engineers' Handbook Perry, J. (ed.), Section 8. Diffusional Operations. pg 538. 3rd Edition. McGraw-Hill Book Co., (1950).
- "Chromatography" (Chemical and Engineering News Staff Report) Chemical and Engineering News 30 4244 (1952).
- Daynes, H. A., Gas Analysis by Measurement of Thermal Conductivity. Cambridge University Press (1933).
- Dushman, S., Scientific Foundations of Vacuum Technique John Wiley and Sons, Inc. (1949).
- Gregg, S. J., The Surface Chemistry of Solids.
- Hartman, Colloid Chemistry 2nd Edition. Houghton-Mifflin Co., (1949).
- International Critical Tables, Vol. 3, pp.250-251. McGraw-Hill Book Co., New York (1928).
- Klotz, I. M., "The Adsorption Wave" Chemical Reviews, Vol. 39 pp241 (1946).
- Ledoux, E., Vapor Adsorption, Chemical Publishing Co., Inc., New York (1945).
- Mantell, C. L., Adsorption, 2nd Edition. McGraw-Hill Book Co., New York (1951).

REFERENCES CONT'D

- McBain, J. W., The Sorption of Gases and Vapors by Solids, London (1932).
- Robinson, C. S., The Recovery Of Vapors, Reinhold Publishing Corp., New York (1942).
- Rose, A. and Rose, E., Distillation Literature, Index and Abstracts, 1946-52 Inclusive, Applied Science Laboratories, Inc., State College, Pennsylvania (1953).
- Sanderson, E., Vacuum Manipulation of Volatile Compounds, John Wiley and Sons, Inc., New York (1948).
- Sherwood and Pigford, Adsorption and Extraction, McGraw-Hill Book Co., New York.
- Strain, H. H., Chromatographic Adsorption Analysis, Interscience Publishers, Inc., New York (1945).
- Willard, Merritt and Dean, Instrumental Methods of Analysis, Van Nostrand (1952).